



**THE DATASHEET OF
HRS1KH-S-DC24V**



Note that the HT12F device, although mentioned in this datasheet, has already been phased out and is presently no longer available.

Features

- Operating voltage: 2.4V~12V
- Low power and high noise immunity CMOS technology
- Low standby current
- Capable of decoding 12 bits of information
- Binary address setting
- Received codes are checked 3 times
- Address/Data number combination
 - HT12D: 8 address bits and 4 data bits
 - HT12F: 12 address bits only
- Built-in oscillator needs only 5% resistor
- Valid transmission indicator
- Easy interface with an RF or an infrared transmission medium
- Minimal external components
- Pair with Holtek's 2¹² series of encoders
- 18-pin DIP, 20-pin SOP package

Applications

- Burglar alarm system
- Smoke and fire alarm system
- Garage door controllers
- Car door controllers
- Car alarm system
- Security system
- Cordless telephones
- Other remote control systems

General Description

The 2¹² decoders are a series of CMOS LSIs for remote control system applications. They are paired with Holtek's 2¹² series of encoders (refer to the encoder/decoder cross reference table). For proper operation, a pair of encoder/decoder with the same number of addresses and data format should be chosen.

The decoders receive serial addresses and data from a programmed 2¹² series of encoders that are transmitted by a carrier using an RF or an IR transmission medium. They compare the serial input data three times continu-

ously with their local addresses. If no error or unmatched codes are found, the input data codes are decoded and then transferred to the output pins. The VT pin also goes high to indicate a valid transmission.

The 2¹² series of decoders are capable of decoding informations that consist of N bits of address and 12–N bits of data. Of this series, the HT12D is arranged to provide 8 address bits and 4 data bits, and HT12F is used to decode 12 bits of address information.

Selection Table

Function Part No.	Address No.	Data		VT	Oscillator	Trigger	Package
		No.	Type				
HT12D	8	4	L	√	RC oscillator	DIN active "Hi"	20SOP
HT12F	12	0	—	√	RC oscillator	DIN active "Hi"	18DIP, 20SOP

Notes: Data type: L stands for latch type data output.

VT can be used as a momentary data output.

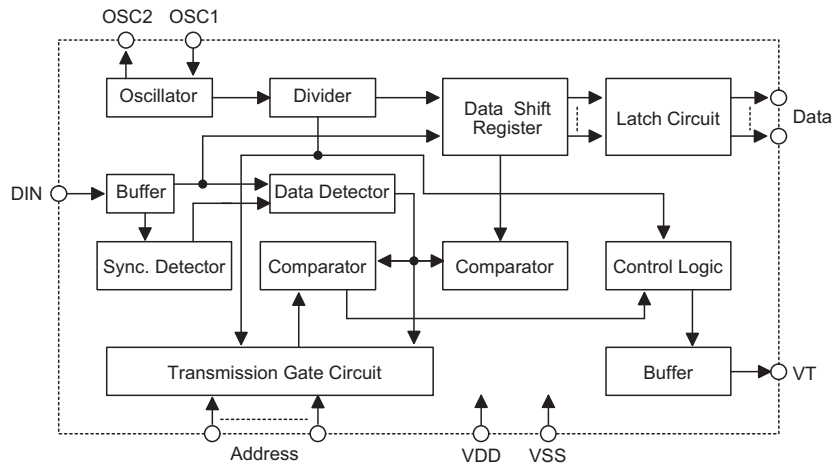
Block Diagram

Note: The address/data pins are available in various combinations (see the address/data table).

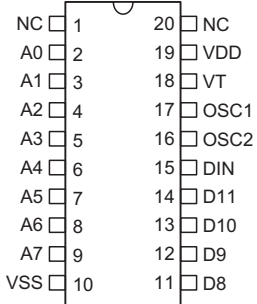
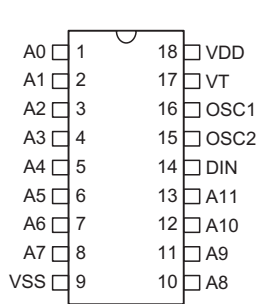
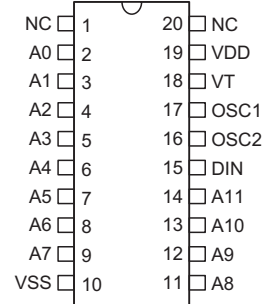
Pin Assignment
**8-Address
4-Data**

**HT12D
20 SOP-A**
**12-Address
0-Data**

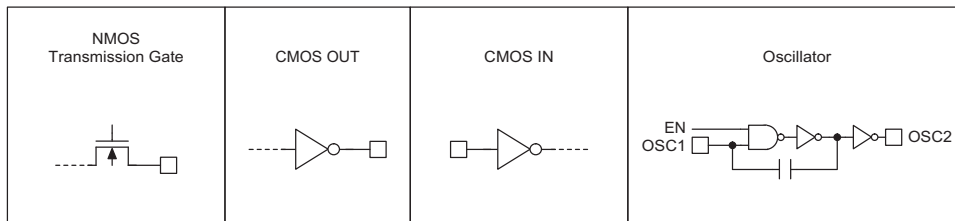
**HT12F
18 DIP-A**
**12-Address
0-Data**

**HT12F
20 SOP-A**
Pin Description

Pin Name	I/O	Internal Connection	Description
A0~A11 (HT12F)	I	NMOS Transmission Gate	Input pins for address A0~A11 setting These pins can be externally set to VSS or left open.
A0~A7 (HT12D)			Input pins for address A0~A7 setting These pins can be externally set to VSS or left open.
D8~D11 (HT12D)	O	CMOS OUT	Output data pins, power-on state is low.
DIN	I	CMOS IN	Serial data input pin
VT	O	CMOS OUT	Valid transmission, active high
OSC1	I	Oscillator	Oscillator input pin
OSC2	O	Oscillator	Oscillator output pin
VSS	—	—	Negative power supply, ground
VDD	—	—	Positive power supply

Approximate internal connection circuits

Absolute Maximum Ratings

Supply Voltage	-0.3V to 13V	Storage Temperature	-50°C to 125°C
Input Voltage	$V_{SS}-0.3$ to $V_{DD}+0.3V$	Operating Temperature	-20°C to 75°C

Note: These are stress ratings only. Stresses exceeding the range specified under "Absolute Maximum Ratings" may cause substantial damage to the device. Functional operation of this device at other conditions beyond those listed in the specification is not implied and prolonged exposure to extreme conditions may affect device reliability.

Electrical Characteristics

Ta=25°C

Symbol	Parameter	Test Conditions		Min.	Typ.	Max.	Unit
		V _{DD}	Conditions				
V _{DD}	Operating Voltage	—	—	2.4	5	12	V
I _{STB}	Standby Current	5V	Oscillator stops	—	0.1	1	μA
		12V		—	2	4	μA
I _{DD}	Operating Current	5V	No load, f _{OSC} =150kHz	—	200	400	μA
I _O	Data Output Source Current (D8~D11)	5V	V _{OH} =4.5V	-1	-1.6	—	mA
	Data Output Sink Current (D8~D11)	5V	V _{OL} =0.5V	1	1.6	—	mA
I _{VT}	VT Output Source Current	5V	V _{OH} =4.5V	-1	-1.6	—	mA
	VT Output Sink Current		V _{OL} =0.5V	1	1.6	—	mA
V _{IH}	"H" Input Voltage	5V	—	3.5	—	5	V
V _{IL}	"L" Input Voltage	5V	—	0	—	1	V
f _{OSC}	Oscillator Frequency	5V	R _{OSC} =51kΩ	—	150	—	kHz

Functional Description

Operation

The 2¹² series of decoders provides various combinations of addresses and data pins in different packages so as to pair with the 2¹² series of encoders.

The decoders receive data that are transmitted by an encoder and interpret the first N bits of code period as addresses and the last 12-N bits as data, where N is the address code number. A signal on the DIN pin activates the oscillator which in turn decodes the incoming address and data. The decoders will then check the received address three times continuously. If the received address codes all match the contents of the decoder's local address, the 12-N bits of data are decoded to activate the output pins and the VT pin is set high to indicate a valid transmission. This will last unless the address code is incorrect or no signal is received.

The output of the VT pin is high only when the transmission is valid. Otherwise it is always low.

Output Type

Of the 2¹² series of decoders, the HT12F has no data output pin but its VT pin can be used as a momentary data output. The HT12D, on the other hand, provides 4 latch type data pins whose data remain unchanged until new data are received.

Part No.	Data Pins	Address Pins	Output Type	Operating Voltage
HT12D	4	8	Latch	2.4V~12V
HT12F	0	12	—	2.4V~12V

Flowchart

The oscillator is disabled in the standby state and activated when a logic "high" signal applies to the DIN pin. That is to say, the DIN should be kept low if there is no signal input.

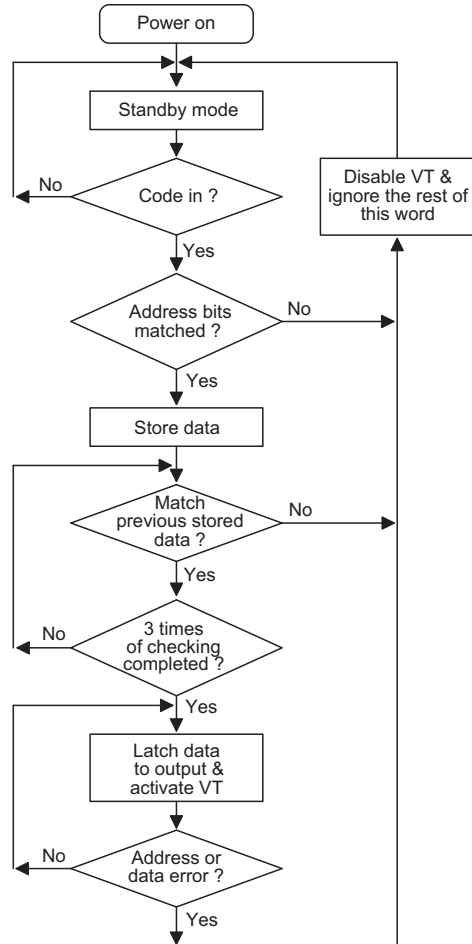

Decoder Timing

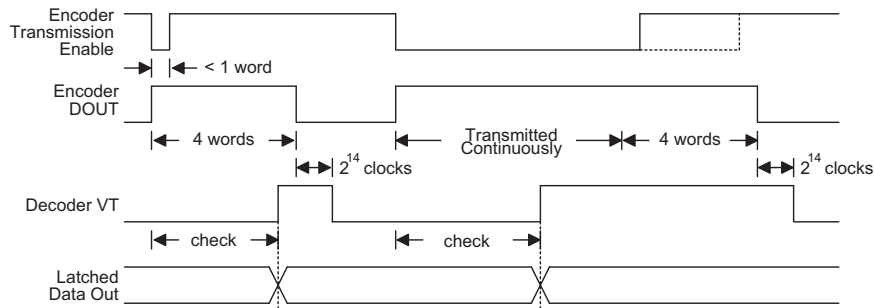

Encoder/Decoder Cross Reference Table

Decoders Part No.	Data Pins	Address Pins	VT	Pair Encoder	Package			
					Encoder		Decoder	
					DIP	SOP	DIP	SOP
HT12D	4	8	√	HT12A HT12E	—	20	—	20
HT12F	0	12	√	HT12A HT12E	18	20	18	20

Address/Data Sequence

The following table provides address/data sequence for various models of the 2¹² series of decoders.

Part No.	Address/Data Bits											
	0	1	2	3	4	5	6	7	8	9	10	11
HT12D	A0	A1	A2	A3	A4	A5	A6	A7	D8	D9	D10	D11
HT12F	A0	A1	A2	A3	A4	A5	A6	A7	A8	A9	A10	A11

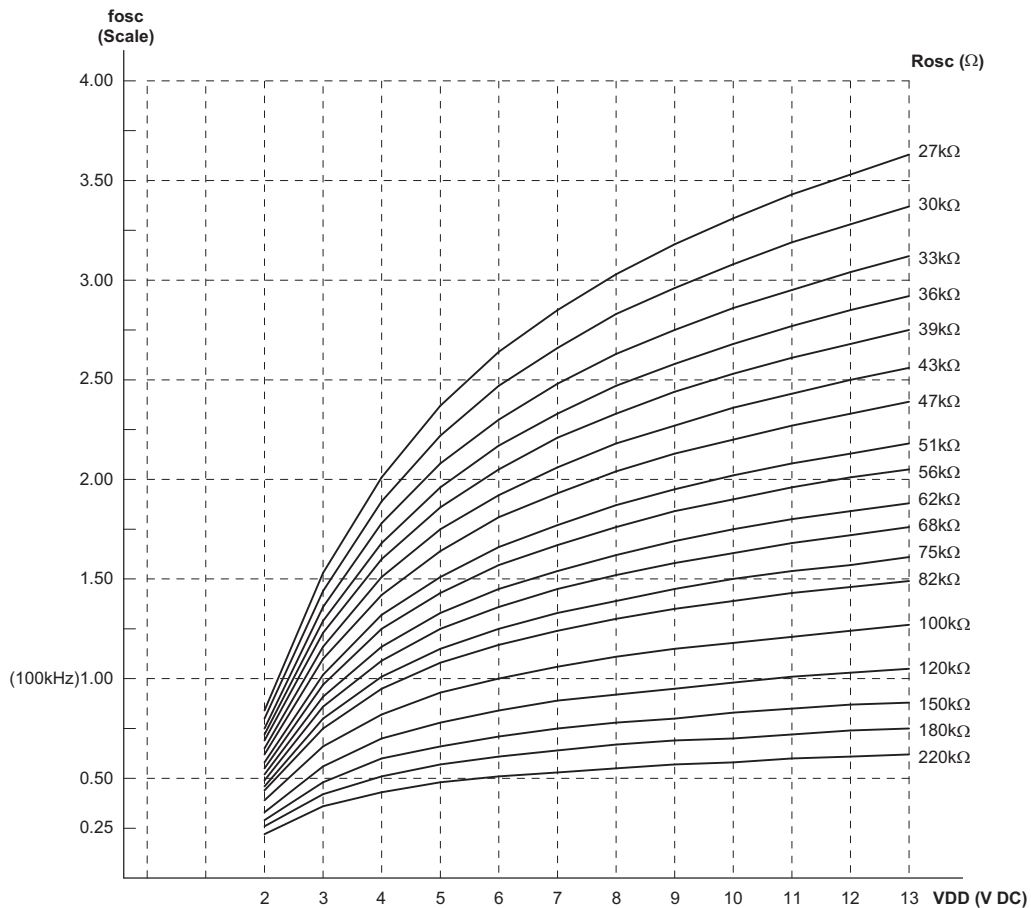
Oscillator Frequency Vs Supply Voltage

Note: The recommended oscillator frequency is $f_{OSCD} \text{ (decoder)} \cong 50 f_{OSCE} \text{ (HT12E encoder)}$
 $\cong \frac{1}{3} f_{OSCE} \text{ (HT12A encoder)}$.

Application Circuits

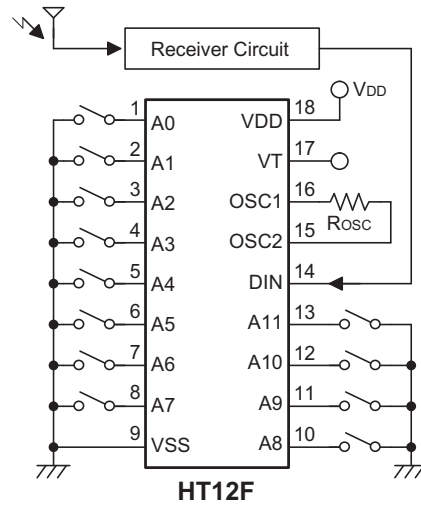
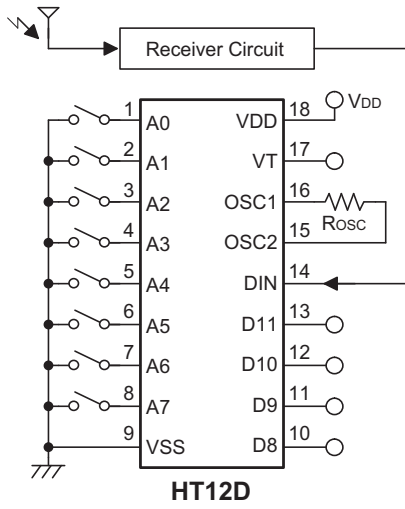

Package Information

Note that the package information provided here is for consultation purposes only. As this information may be updated at regular intervals users are reminded to consult the [Holtek website](#) for the latest version of the [Package/Carton Information](#).

Additional supplementary information with regard to packaging is listed below. Click on the relevant section to be transferred to the relevant website page.

- [Further Package Information \(include Outline Dimensions, Product Tape and Reel Specifications\)](#)
- [Packing Materials Information](#)
- [Carton Information](#)

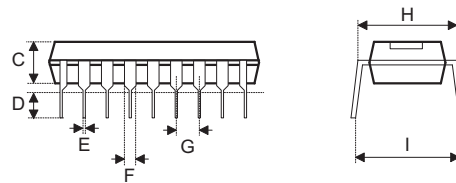
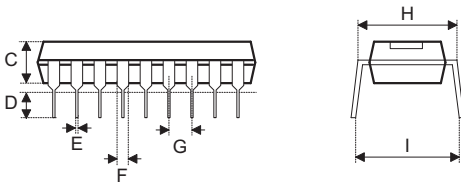
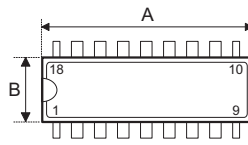
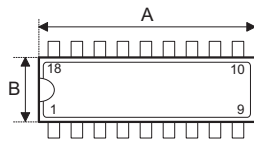
18-pin DIP (300mil) Outline Dimensions

Fig1. Full Lead Packages
Fig2. 1/2 Lead Packages

• see fig1

Symbol	Dimensions in inch		
	Min.	Nom.	Max.
A	0.880	0.900	0.920
B	0.240	0.250	0.280
C	0.115	0.130	0.195
D	0.115	0.130	0.150
E	0.014	0.018	0.022
F	0.045	0.060	0.070
G	—	0.1 BSC	—
H	0.300	0.310	0.325
I	—	—	0.430

Symbol	Dimensions in mm		
	Min.	Nom.	Max.
A	22.35	22.86	23.37
B	6.10	6.35	7.11
C	2.92	3.30	4.95
D	2.92	3.30	3.81
E	0.36	0.46	0.56
F	1.14	1.52	1.78
G	—	2.54 BSC	—
H	7.62	7.87	8.26
I	—	—	10.92

• see fig2

Symbol	Dimensions in inch		
	Min.	Nom.	Max.
A	0.845	0.865	0.885
B	0.275	0.285	0.295
C	0.120	0.135	0.150
D	0.110	0.130	0.150
E	0.014	0.018	0.022
F	0.045	0.050	0.060
G	—	0.1 BSC	—
H	0.300	0.310	0.325
I	—	—	0.430

Symbol	Dimensions in mm		
	Min.	Nom.	Max.
A	21.46	21.97	22.48
B	6.99	7.24	7.49
C	3.05	3.43	3.81
D	2.79	3.30	3.81
E	0.36	0.46	0.56
F	1.14	1.27	1.52
G	—	2.54 BSC	—
H	7.62	7.87	8.26
I	—	—	10.92

• see fig2

Symbol	Dimensions in inch		
	Min.	Nom.	Max.
A	0.845	0.870	0.880
B	0.240	0.250	0.280
C	0.115	0.130	0.195
D	0.115	0.130	0.150
E	0.014	0.018	0.022
F	0.045	0.060	0.070
G	—	0.1 BSC	—
H	0.300	0.310	0.325
I	—	—	0.430

Symbol	Dimensions in mm		
	Min.	Nom.	Max.
A	21.46	22.10	22.35
B	6.10	6.35	7.11
C	2.92	3.30	4.95
D	2.92	3.30	3.81
E	0.36	0.46	0.56
F	1.14	1.52	1.78
G	—	2.54 BSC	—
H	7.62	7.87	8.26
I	—	—	10.92

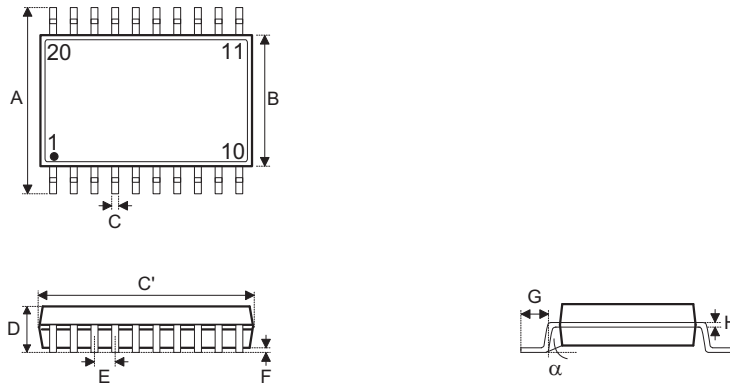
20-pin SOP (300mil) Outline Dimensions

Symbol	Dimensions in inch		
	Min.	Nom.	Max.
A	—	0.406 BSC	—
B	—	0.295 BSC	—
C	0.012	—	0.020
C'	—	0.504 BSC	—
D	—	—	0.104
E	—	0.050 BSC	—
F	0.004	—	0.012
G	0.016	—	0.050
H	0.008	—	0.013
α	0°	—	8°

Symbol	Dimensions in mm		
	Min.	Nom.	Max.
A	—	10.30 BSC	—
B	—	7.50 BSC	—
C	0.31	—	0.51
C'	—	12.80 BSC	—
D	—	—	2.65
E	—	1.27 BSC	—
F	0.10	—	0.30
G	0.40	—	1.27
H	0.20	—	0.33
α	0°	—	8°

Copyright © 2022 by HOLTEK SEMICONDUCTOR INC.

The information appearing in this Data Sheet is believed to be accurate at the time of publication. However, Holtek assumes no responsibility arising from the use of the specifications described. The applications mentioned herein are used solely for the purpose of illustration and Holtek makes no warranty or representation that such applications will be suitable without further modification, nor recommends the use of its products for application that may present a risk to human life due to malfunction or otherwise. Holtek's products are not authorized for use as critical components in life support devices or systems. Holtek reserves the right to alter its products without prior notification. For the most up-to-date information, please visit our website at <http://www.holtek.com>.

Looking for pricing, stock, or lifecycle information?

Click below to explore more details on WIN SOURCE:

- [View HRS1KH-S-DC24V on WIN SOURCE](#)
- [Zhejiang HKE Relay Co.,Ltd. Information](#)

Optimize Your Supply Chain with WIN SOURCE Solutions

- ✓ Global Sourcing Solution
- ✓ Obsolete Management
- ✓ Cost Control Management
- ✓ Shortage Management
- ✓ Alternative Solution
- ✓ Excess Inventory Management