



**THE DATASHEET OF  
UWX1E4R7KCL1GB**



# UWX

5.5mmL Chip Type



For SMD



Anti-Solvent Feature

- Chip type with 5.5mm height.
- Designed for surface mounting on high density PC board.
- Applicable to automatic mounting machine fed with carrier tape.
- Load life of 2000 hours at 85°C.
- Compliant to the RoHS directive (2011/65/EU,(EU)2015/863).
- AEC-Q200 compliant. Please contact us for details.

Products which are scheduled to be discontinued.  
Not recommended for new designs.

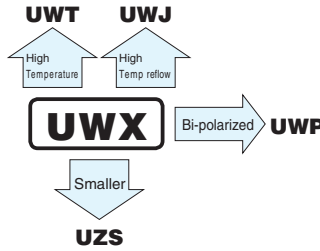

## Specifications

Item	Performance Characteristics																							
Category Temperature Range	-40 to +85°C																							
Rated Voltage Range	4 to 50V																							
Rated Capacitance Range	1 to 330μF																							
Capacitance Tolerance	±20% at 120Hz, 20°C																							
Leakage Current ※	After 2 minutes' application of rated voltage at 20°C, leakage current is not more than 0.01CV or 3 (μA) ,whichever is greater.																							
Tangent of loss angle (tan δ)	Measurement frequency : 120Hz at 20°C																							
	<table border="1"> <thead> <tr> <th>Rated voltage (V)</th> <th>4</th> <th>6.3</th> <th>10</th> <th>16</th> <th>25</th> <th>35</th> <th>50</th> </tr> </thead> <tbody> <tr> <td>tan δ (max.)</td> <td>0.35 (0.40)</td> <td>0.26 (0.30)</td> <td>0.20 (0.24)</td> <td>0.16 (0.19)</td> <td>0.14 (0.16)</td> <td>0.12 (0.14)</td> <td>0.12 (0.14)</td> </tr> </tbody> </table> <p>Values in ( ) applicable to WR.</p>	Rated voltage (V)	4	6.3	10	16	25	35	50	tan δ (max.)	0.35 (0.40)	0.26 (0.30)	0.20 (0.24)	0.16 (0.19)	0.14 (0.16)	0.12 (0.14)	0.12 (0.14)							
Rated voltage (V)	4	6.3	10	16	25	35	50																	
tan δ (max.)	0.35 (0.40)	0.26 (0.30)	0.20 (0.24)	0.16 (0.19)	0.14 (0.16)	0.12 (0.14)	0.12 (0.14)																	
Stability at Low Temperature	Measurement frequency : 120Hz																							
	<table border="1"> <thead> <tr> <th>Rated voltage (V)</th> <th>4</th> <th>6.3</th> <th>10</th> <th>16</th> <th>25</th> <th>35</th> <th>50</th> </tr> </thead> <tbody> <tr> <td>Impedance ratio Z(-25°C) / Z(+20°C)</td> <td>7</td> <td>4</td> <td>3</td> <td>2</td> <td>2</td> <td>2</td> <td>2</td> </tr> <tr> <td>ZT / Z20 (max.)</td> <td>Z(-40°C) / Z(+20°C)</td> <td>15</td> <td>8</td> <td>8</td> <td>4</td> <td>4</td> <td>3</td> </tr> </tbody> </table>	Rated voltage (V)	4	6.3	10	16	25	35	50	Impedance ratio Z(-25°C) / Z(+20°C)	7	4	3	2	2	2	2	ZT / Z20 (max.)	Z(-40°C) / Z(+20°C)	15	8	8	4	4
Rated voltage (V)	4	6.3	10	16	25	35	50																	
Impedance ratio Z(-25°C) / Z(+20°C)	7	4	3	2	2	2	2																	
ZT / Z20 (max.)	Z(-40°C) / Z(+20°C)	15	8	8	4	4	3																	
Endurance	<p>The specifications listed at right shall be met when the capacitors are restored to 20°C after the rated voltage is applied for 2000 hours at 85°C.</p> <table border="1"> <tbody> <tr> <td>Capacitance change</td> <td>Within ±20% of the initial capacitance value (Within ±25% for 4 V and WR series units)</td> </tr> <tr> <td>tan δ</td> <td>200% or less than the initial specified value</td> </tr> <tr> <td>Leakage Current</td> <td>Less than or equal to the initial specified value</td> </tr> </tbody> </table>	Capacitance change	Within ±20% of the initial capacitance value (Within ±25% for 4 V and WR series units)	tan δ	200% or less than the initial specified value	Leakage Current	Less than or equal to the initial specified value																	
Capacitance change	Within ±20% of the initial capacitance value (Within ±25% for 4 V and WR series units)																							
tan δ	200% or less than the initial specified value																							
Leakage Current	Less than or equal to the initial specified value																							
Shelf Life	After storing the capacitors under no load at 85°C for 1000 hours and then performing voltage treatment based on JIS C 5101-4 clause 4.1 at 20°C, they shall meet the specified values for the endurance characteristics listed above.																							
Resistance to soldering heat	<p>The capacitors are kept on a hot plate for 30 seconds, which is maintained at 250°C. The capacitors shall meet the characteristic requirements listed at right when they are removed from the plate and restored to 20°C.</p> <table border="1"> <tbody> <tr> <td>Capacitance change</td> <td>Within ±10% of the initial capacitance value</td> </tr> <tr> <td>tan δ</td> <td>Less than or equal to the initial specified value</td> </tr> <tr> <td>Leakage current</td> <td>Less than or equal to the initial specified value</td> </tr> </tbody> </table>	Capacitance change	Within ±10% of the initial capacitance value	tan δ	Less than or equal to the initial specified value	Leakage current	Less than or equal to the initial specified value																	
Capacitance change	Within ±10% of the initial capacitance value																							
tan δ	Less than or equal to the initial specified value																							
Leakage current	Less than or equal to the initial specified value																							
Marking	Black print on the case top.																							

※ I : Leakage Current (μA), C : Rated Capacitance (μF), V : Rated Voltage (V)

## Chip Type

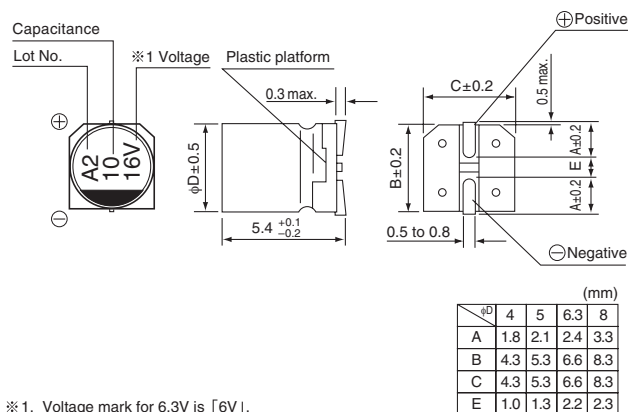

## Type numbering system (Example : 16V 10μF)

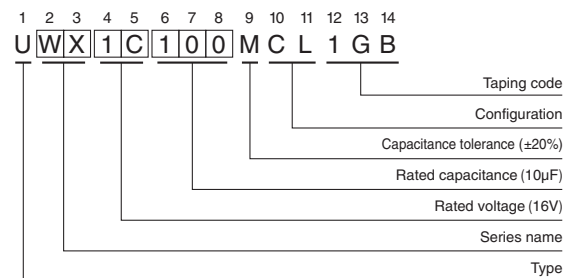

## Frequency coefficient of rated ripple current

Frequency	50 Hz	120 Hz	300 Hz	1 kHz	10 kHz or more
Coefficient	0.70	1.00	1.17	1.36	1.50

● Dimension table in next page.

UWX

## ■ Dimensions

Rated Voltage (V) (code)	Rated Capacitance ( $\mu$ F)	Case Size $\phi$ D×L (mm)	tan $\delta$	Leakage Current ( $\mu$ A) (at 20°C after 2 minutes)	Rated Ripple (mArms) (85°C/120Hz)	Part Number
4 (0G)	33	4×5.4	0.35	3	28	UWX0G330MCL1GB
	47	4×5.4	0.35	3	33	UWX0G470MCL1GB
	56	5×5.4	0.35	3	42	UWX0G560MCL1GB
	100	5×5.4	0.35	4	56	UWX0G101MCL1GB
	150	6.3×5.4	0.35	6	79	UWX0G151MCL1GB
	220	6.3×5.4	0.35	8.8	96	UWX0G221MCL1GB
	330	8×5.4	0.35	13.2	145	UWX0G331MCL1GB
6.3 (0J)	22	4×5.4	0.26	3	28	UWX0J220MCL1GB
	33	5×5.4	0.26	3	37	UWX0J330MCL1GB
	33	4×5.4	0.30	3	34	UWR0J330MCL1GB
	47	5×5.4	0.26	3	45	UWX0J470MCL1GB
	47	4×5.4	0.30	3	40	UWR0J470MCL1GB
	56	6.3×5.4	0.26	3.528	52	UWX0J560MCL1GB
	56	5×5.4	0.30	3.528	46	UWR0J560MCL1GB
	100	6.3×5.4	0.26	6.3	70	UWX0J101MCL1GB
	100	5×5.4	0.30	6.3	47	UWR0J101MCL1GB
	150	6.3×5.4	0.26	9.45	71	UWX0J151MCL1GB
	220	8×5.4	0.26	13.86	110	UWX0J221MCL1GB
	220	6.3×5.4	0.30	13.86	74	UWR0J221MCL1GB
330	8×5.4	0.26	20.79	170	UWX0J331MCL1GB	
10 (1A)	22	5×5.4	0.20	3	33	UWX1A220MCL1GB
	22	4×5.4	0.24	3	30	UWR1A220MCL1GB
	33	5×5.4	0.20	3.3	41	UWX1A330MCL1GB
	33	4×5.4	0.24	3.3	34	UWR1A330MCL1GB
	47	6.3×5.4	0.20	4.7	52	UWX1A470MCL1GB
	47	5×5.4	0.24	4.7	47	UWR1A470MCL1GB
	56	6.3×5.4	0.20	5.6	57	UWX1A560MCL1GB
	56	5×5.4	0.24	5.6	50	UWR1A560MCL1GB
	100	6.3×5.4	0.20	10	76	UWX1A101MCL1GB
	100	5×5.4	0.24	10	54	UWR1A101MCL1GB
	150	8×5.4	0.20	15	111	UWX1A151MCL1GB
	150	6.3×5.4	0.24	15	76	UWR1A151MCL1GB
220	8×5.4	0.20	22	135	UWX1A221MCL1GB	
16 (1C)	10	4×5.4	0.16	3	23	UWX1C100MCL1GB
	22	5×5.4	0.16	3.52	37	UWX1C220MCL1GB
	22	4×5.4	0.19	3.52	30	UWR1C220MCL1GB
	33	6.3×5.4	0.16	5.28	49	UWX1C330MCL1GB
	33	5×5.4	0.19	5.28	44	UWR1C330MCL1GB
	47	6.3×5.4	0.16	7.52	58	UWX1C470MCL1GB
	47	5×5.4	0.19	7.52	52	UWR1C470MCL1GB
	56	6.3×5.4	0.16	8.96	63	UWX1C560MCL1GB
	56	5×5.4	0.19	8.96	57	UWR1C560MCL1GB
	100	6.3×5.4	0.16	16	86	UWX1C101MCL1GB

UWX

## ■ Dimensions

Rated Voltage (V) (code)	Rated Capacitance (μF)	Case Size φD×L (mm)	tan δ	Leakage Current (μA) (at 20°C after 2 minutes)	Rated Ripple (mA <sub>rms</sub> ) (85°C/120Hz)	Part Number
25 (1E)	4.7	4×5.4	0.14	3	16	UWX1E4R7MCL1GB
	10	5×5.4	0.14	3	27	UWX1E100MCL1GB
	10	4×5.4	0.16	3	24	UWR1E100MCL1GB
	22	6.3×5.4	0.14	5.5	42	UWX1E220MCL1GB
	22	5×5.4	0.16	5.5	38	UWR1E220MCL1GB
	33	6.3×5.4	0.14	8.25	52	UWX1E330MCL1GB
	33	5×5.4	0.16	8.25	46	UWR1E330MCL1GB
	47	8×5.4	0.14	11.75	70	UWX1E470MCL1GB
	47	6.3×5.4	0.16	11.75	60	UWR1E470MCL1GB
	56	8×5.4	0.14	14	76	UWX1E560MCL1GB
	56	6.3×5.4	0.16	14	65	UWR1E560MCL1GB
100	8×5.4	0.14	25	110	UWX1E101MCL1GB	
35 (1V)	4.7	4×5.4	0.12	3	18	UWX1V4R7MCL1GB
	10	5×5.4	0.12	3.5	29	UWX1V100MCL1GB
	10	4×5.4	0.14	3.5	24	UWR1V100MCL1GB
	22	6.3×5.4	0.12	7.7	46	UWX1V220MCL1GB
	22	5×5.4	0.14	7.7	39	UWR1V220MCL1GB
	33	8×5.4	0.12	11.55	62	UWX1V330MCL1GB
	33	6.3×5.4	0.14	11.55	53	UWR1V330MCL1GB
	47	8×5.4	0.12	16.45	80	UWX1V470MCL1GB
50 (1H)	1	4×5.4	0.12	3	8.4	UWX1H010MCL1GB
	2.2	4×5.4	0.12	3	13	UWX1H2R2MCL1GB
	3.3	4×5.4	0.12	3	17	UWX1H3R3MCL1GB
	4.7	5×5.4	0.12	3	20	UWX1H4R7MCL1GB
	4.7	4×5.4	0.14	3	18	UWR1H4R7MCL1GB
	10	6.3×5.4	0.12	5	33	UWX1H100MCL1GB
	10	5×5.4	0.14	5	30	UWR1H100MCL1GB
	22	8×5.4	0.12	11	52	UWX1H220MCL1GB
	22	6.3×5.4	0.14	11	43	UWR1H220MCL1GB
	33	8×5.4	0.12	16.5	71	UWX1H330MCL1GB

- For taping specifications, recommended land size/soldering by reflow and minimum order quantity, please refer to the Guidelines for Aluminum Electrolytic Capacitors.
- Please select UUR, UUG if high C/V products are required.

## Looking for pricing, stock, or lifecycle information?

Click below to explore more details on WIN SOURCE:

 [View UWX1E4R7KCL1GB on WIN SOURCE](#)

 [Nichicon Information](#)

## Optimize Your Supply Chain with WIN SOURCE Solutions

-  Global Sourcing Solution
-  Obsolete Management
-  Cost Control Management
-  Shortage Management
-  Alternative Solution
-  Excess Inventory Management