



**THE DATASHEET OF
GD25D40CTIG**



DIO6930

High-Efficiency 3 A, 24 V Input Synchronous Step-Down Converter

Features

- Low $R_{DS(ON)}$ for internal switches (top/bottom) 80 m Ω /40 m Ω , 3.0 A
- 4.5 ~ 24 V input voltage range
- High-efficiency synchronous mode
- Internal soft-start limits the inrush current
- Over-current protection
- Thermal shutdown
- Available in the TSOT23-6 package

Applications

- Portable navigation devices
- Set top boxes
- Portable TVs
- LCD TVs

Descriptions

The DIO6930 is a high-efficiency, high-frequency synchronous step-down DC-DC regulator IC capable of delivering up to 3 A output currents. The DIO6930 family operates over a wide input voltage range from 4.5 V to 24 V and integrates with the main switch and synchronous switch with very low $R_{DS(ON)}$ to minimize the conduction loss.

The COT architecture with a pseudo-fixed switching frequency operation provides a fast transient response and eases loop stabilization. The DIO6930 operates in pulse skip mode, which maintains high efficiency during a light load operation.

Protection features include over-current protection and thermal shutdown.

The DIO6930 requires a minimal number of readily-available, standard, external components and is available in a space-saving TSOT23-6 package.

Function Block

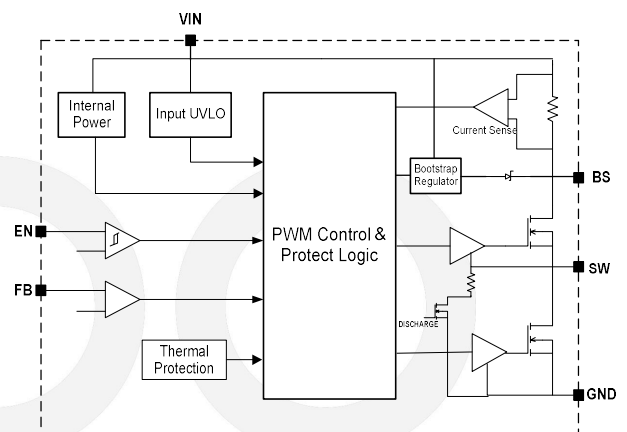

Ordering Information

Part Number	Top Marking	RoHS	T _A	Package	
DIO6930TST6	30YW	Green	-40 to 85°C	TSOT23-6	Tape & Reel, 3000

Pin Assignments

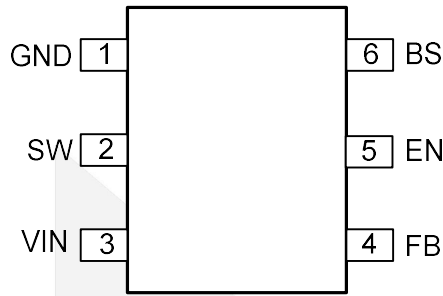

TSOT23-6

Figure 1. Pin assignment (Top view)

Pin Definitions

Pin Name	Description
GND	Power ground.
SW	Inductor pin. Connect this pin to the switching node of inductor.
VIN	Power input.
FB	Output feedback pin. Connect this pin to the center point of the output resistor divider (as shown in Figure 2) to program the output voltage: $V_{OUT} = 0.765 \times (1 + R1/R2)$. Add optional C2 (10 pF ~ 47 pF) to speed up the transient response.
EN	Enable control. Pull high to turn on. Do not float.
BS	Bootstrap. Connect a capacitor and a resistor between SW and BS pins to form a floating supply across the high-side switch driver. Recommend to use a 0.1 μ F BS capacitor.

Absolute Maximum Ratings

Stresses beyond those listed under the Absolute Maximum Rating table may cause permanent damage to the device. These are stress ratings only and functional operation of the device at these or any other condition beyond those indicated in the operational sections of the specifications is not implied. Exposure to absolute maximum rating conditions for extended periods may affect device reliability.

Symbol	Parameter	Rating	Unit
V_S	Supply voltage (V_+ – V_-)	28	V
	EN, SW voltage	$V_{IN} + 0.3$	V
	FB voltage	6	V
	BS voltage	$SW + 6$	V
Θ_{JA}	Junction-to-ambient thermal resistance	87.9	°C/W
Θ_{JC}	Junction-to-case thermal resistance	42.2	
T_{STG}	Storage temperature range	-65 to 150	°C
T_J	Junction temperature range	150	°C
T_L	Lead temperature range	260	°C

Recommend Operating Conditions

The Recommended Operating Conditions table defines the conditions for actual device operation. Recommended operating conditions are specified to ensure optimal performance to the datasheet specifications. DIOO does not recommend exceeding them or designing to absolute maximum ratings.

Symbol	Parameter	Rating	Unit
V_S	Supply voltage	4.5 to 24	V
T_J	Junction temperature range	-40 to 125	°C
T_A	Ambient temperature range	-40 to 85	°C



DIO6930

High-Efficiency 3 A, 24 V Input Synchronous Step Down Converter

Electrical Characteristics

$V_{IN} = 12\text{ V}$, $V_{OUT} = 1.2\text{ V}$, $L = 2.2\text{ }\mu\text{H}$, $C_{OUT} = 47\text{ }\mu\text{F}$, $T_A = 25^\circ\text{C}$, $I_{OUT} = 1\text{ A}$ unless otherwise specified.

Symbol	Parameter	Test Conditions	Min	Typ	Max	Unit
V_{IN}	Input voltage range		4.5		24	V
I_Q	Quiescent current	$I_{OUT} = 0$, $V_{FB} = V_{REF} \times 105\%$		140		μA
I_{SHDN}	Shutdown current	$EN = 0$		5	10	μA
V_{REF}	Feedback reference voltage		0.754	0.765	0.776	V
I_{FB}	FB input current	$V_{FB} = 3.3\text{ V}$	-50		50	nA
$R_{DS(ON)}$	Top FET R_{ON}			80		m Ω
$R_{DS(ON)}$	Bottom FET R_{ON}			40		m Ω
I_{LIM}	Low side power FET current limit		3.0	4.0		A
V_{ENH}	EN rising threshold		1.5			V
V_{ENL}	EN falling threshold				0.4	V
V_{UVLO}	V_{IN} undervoltage unlock threshold, rising				4.45	V
f_{SW}	Switching frequency			500		kHz
	Min on time			40		ns
	Min off time			180		ns
t_{SS}	Soft-start time			1		ms
T_{SD}	Thermal shutdown temperature			148		$^\circ\text{C}$
T_{HYS}	Thermal shutdown hysteresis			20		$^\circ\text{C}$

Specifications subject to change without notice.

Typical Application

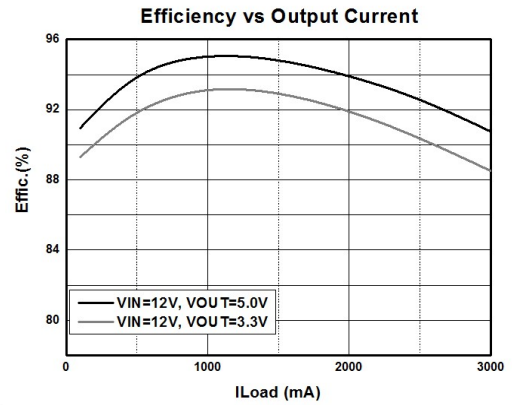
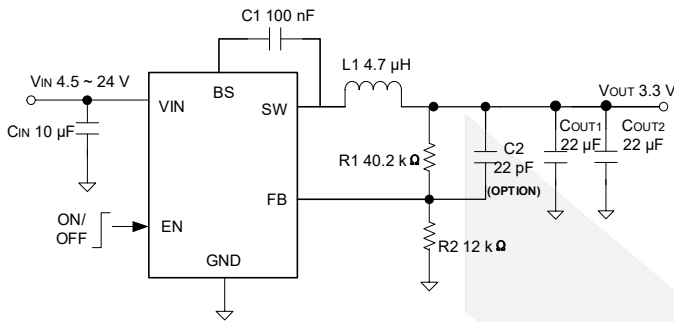
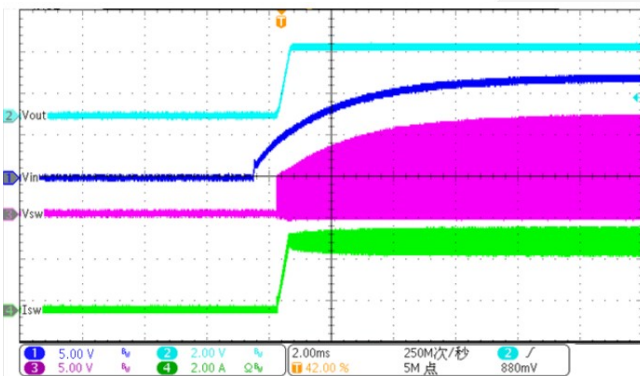

Figure 2. Typical application

Typical Performance Characteristics

Start up from VIN

(VIN = 12 V, VOUT = 3.3 V, Load = 1 Ω)



Shut down from VIN

(VIN = 12 V, VOUT = 3.3 V, Load = 1 Ω)

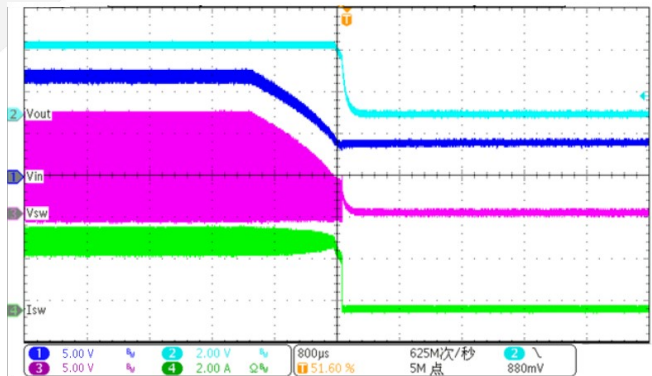

Start up from Enable

(VIN = 12 V, VOUT = 3.3 V, Load = 1 Ω)

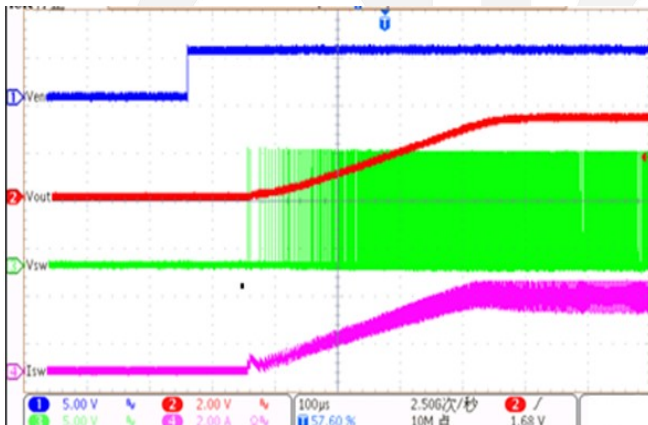

Shut down from Enable

(VIN = 12 V, VOUT = 3.3 V, Load = 1 Ω)

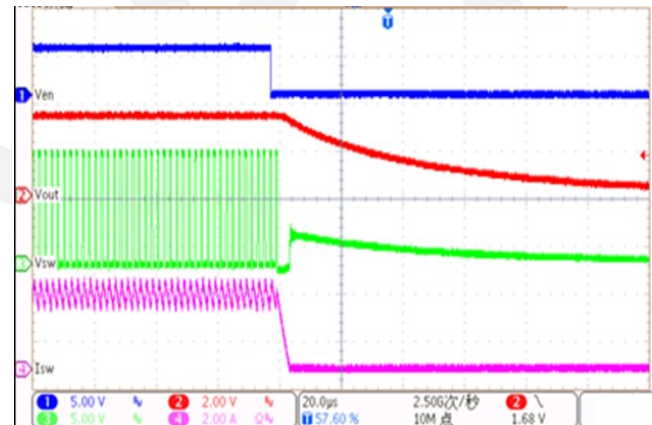

Load transient

($V_{IN} = 12\text{ V}$, $V_{OUT} = 3.3\text{ V}$, Load = 0.3 ~ 3 A)

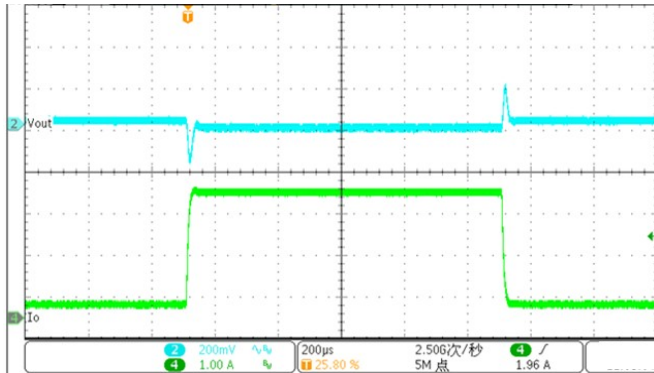

Load transient

($V_{IN} = 12\text{ V}$, $V_{OUT} = 3.3\text{ V}$, Load = 1.5 ~ 3 A)

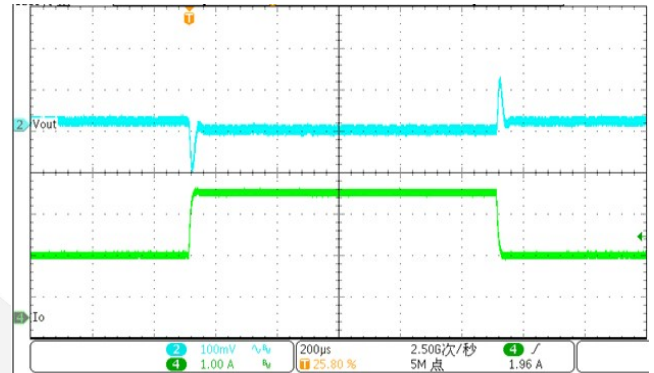

Ripple

($V_{IN} = 12\text{ V}$, $V_{OUT} = 3.3\text{ V}$, Load = 0 A)

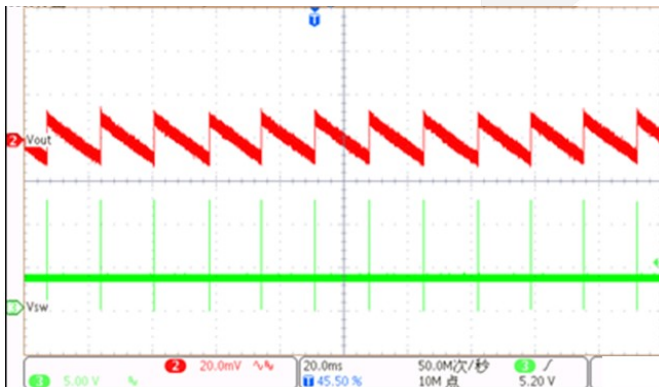

Ripple

($V_{IN} = 12\text{ V}$, $V_{OUT} = 3.3\text{ V}$, Load = 3 A)

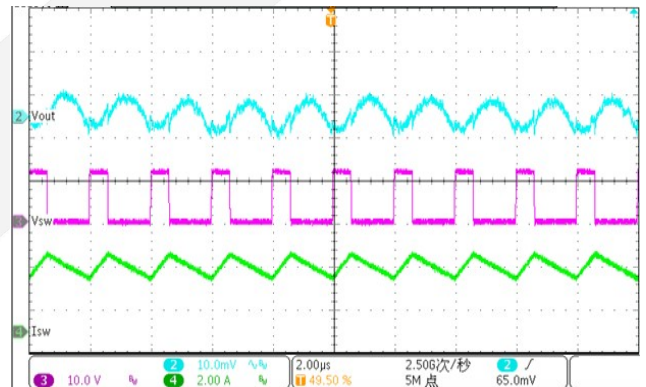

Short-circuit protection

($V_{IN} = 12\text{ V}$, $V_{OUT} = 3.3\text{ V}$, Load = 3 A)

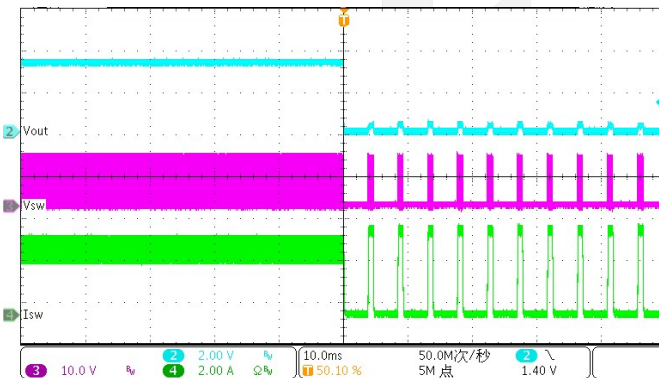

Short-circuit recovery

($V_{IN} = 12\text{ V}$, $V_{OUT} = 3.3\text{ V}$, Load = 3 A)

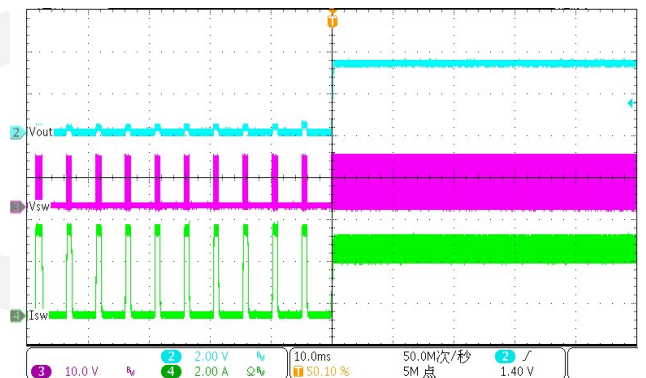

Application Information

The DIO6930 is a synchronous buck regulator IC that integrates the COT control, and top and bottom switches on the same die to minimize the switching transition loss and conduction loss. With ultra-low $R_{DS(ON)}$ power switches and proprietary COT control, this regulator IC can achieve the highest efficiency and the highest switch frequency simultaneously to minimize the external inductor and capacitor size, and thus achieving the minimum solution footprint.

Because of the high integration in the DIO6930 IC, the application circuit based on this regulator IC is rather simple. Only input capacitor C_{IN} , output capacitor C_{OUT} , output inductor L , and feedback resistors ($R1$ and $R2$) need to be selected for the targeted applications specifications.

Feedback resistor dividers $R1$ and $R2$

Choose $R1$ and $R2$ to program the proper output voltage. To minimize the power consumption under light loads, it is desirable to choose large resistance values for both $R1$ and $R2$. A value of between 10 k Ω and 1 M Ω is highly recommended for both resistors. If V_{out} is 3.3 V, and $R1 = 40.2$ k Ω is chosen, then $R2$ can be calculated to be 12 k Ω .

$$R_2 = \frac{0.765V}{V_{out} - 0.765V} \times R_1$$

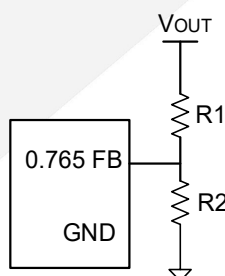

Input capacitor C_{IN}

This ripple current through input capacitor is calculated as:

$$I_{CIN_RMS} = I_{OUT} \times \sqrt{D(1 - D)} \quad 1$$

This formula has a maximum at $V_{IN} = 2V_{OUT}$ condition, where $I_{CIN_RMS} = I_{OUT}/2$. This simple worst-case condition is commonly used for DC/DC design.

To minimize the potential noise problem, place a typical X5R or a better grade ceramic capacitor really close to the IN and GND pins. Care should be taken to minimize the loop area formed by C_{IN} , and IN/GND pins. In this case, a 10 μ F, low ESR ceramic capacitor is recommended.

Output capacitor C_{OUT}

The output capacitor is selected to handle the output ripple noise requirements. Both steady state ripple and transient requirements must be taken into consideration when selecting this capacitor. For the best

performance, it is recommended to use X5R or a better grade ceramic capacitor greater than 22 μF capacitance.

Output inductor L

There are several considerations in choosing this inductor.

- 1) Choose the inductance to provide the desired ripple current. It is suggested to choose the ripple current to be about 40% of the maximum output current. The inductance is calculated as:

$$L = \frac{V_{OUT} \times (1 - V_{OUT} / V_{IN, MAX})}{f_{SW} \times I_{OUT, MAX} \times 40\%} \quad 2$$

where f_{sw} is the switching frequency and $I_{OUT,MAX}$ is the maximum load current. The DIO6930 regulator IC is quite tolerant of different ripple current amplitude. Consequently, the final choice of inductance can be slightly off the calculation value without significantly impacting the performance.

- 2) The saturation current rating of the inductor must be selected to be greater than the peak inductor current under full load conditions.

$$I_{SAT,MIN} > I_{OUT,MAX} + \frac{V_{OUT} \times (1 - V_{OUT} / V_{IN, MAX})}{2 \times f_{SW} \times L} \quad 3$$

- 3) The DCR of the inductor and the core loss at the switching frequency must be low enough to achieve the desired efficiency requirement. It is desirable to choose an inductor with $\text{DCR} < 50 \text{ m}\Omega$ to achieve a good overall efficiency.

Layout Design:

The layout design of DIO6930 regulator is relatively simple. For the best efficiency and minimum noise problems, place the following components close to the IC: C_{IN} , L, R1 and R2.

- 1) Maximize the PCB copper area connected to the GND pin to achieve the best thermal and noise performance. If the board space allows, a ground plane is highly desirable.
- 2) C_{IN} must be close to IN and GND Pins. The loop area formed by C_{IN} and GND must be minimized.
- 3) The PCB copper area associated with SW pin must be minimized to avoid the potential noise problem.
- 4) The components R1 and R2, and the trace connected to the FB pin must NOT be adjacent to the SW net on the PCB layout to avoid the noise problem.
- 5) If the system chip interfacing with the EN pin has a high impedance state at shutdown mode and the IN pin is connected directly to a power source such as a Li-Ion battery, it is desirable to add a pull-down 1 M Ω resistor between the EN and GND pins to prevent the noise from falsely turning on the regulator at shutdown mode.

Physical Dimensions: TSOT23-6

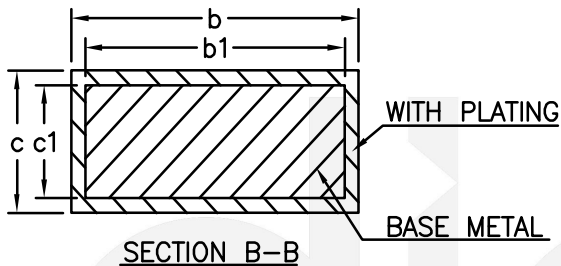
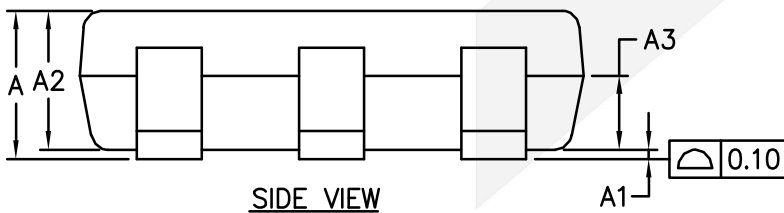
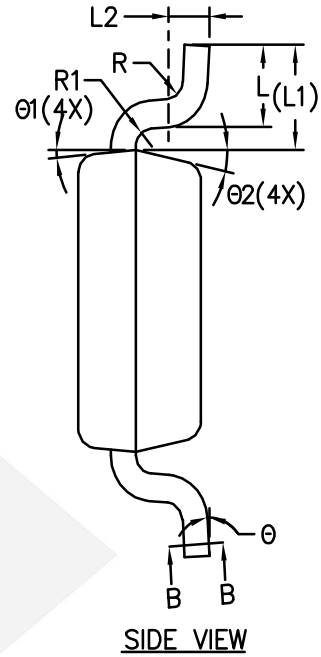
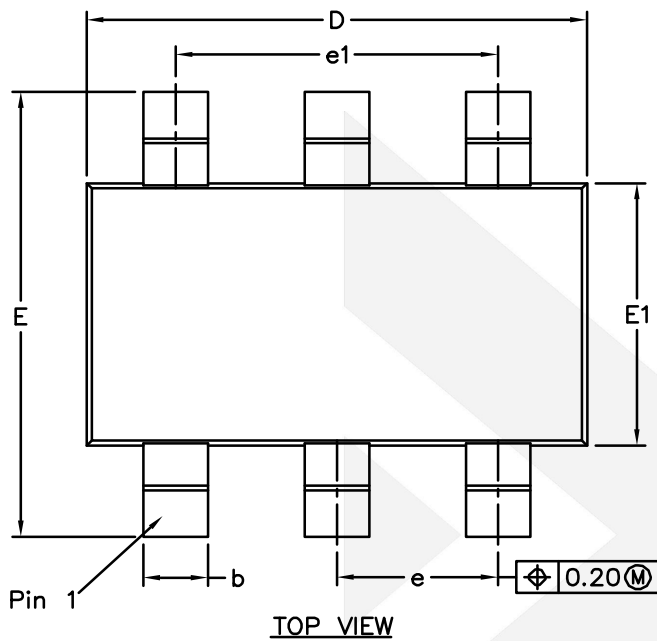

Common Dimensions (mm)			
Symbol	Min	Nom	Max
A	-	-	0.90
A1	0	-	0.15
A2	0.65	0.75	0.85
A3	0.35	0.40	0.45
b	0.36	-	0.50
b1	0.36	0.38	0.45
c	0.14	-	0.20
c1	0.14	0.15	0.16
D	2.85	2.95	3.05
E	2.60	2.80	3.00
E1	1.60	1.65	1.70
e	0.90	0.95	1.00
e1	1.80	1.90	2.00
L	0.30	0.45	0.60
L1	0.575 REF		
L2	0.25 BSC		
R	-	-	0.25
R1	-	-	0.25
θ	0°	-	8°
θ1	3°	5°	7°
θ2	10°	12°	14°



DIO6930

High-Efficiency 3 A, 24 V Input Synchronous Step Down Converter

CONTACT US

Dioo is a professional design and sales corporation for high-quality and performance analog semiconductors. The company focuses on industry markets, such as cell phones, handheld products, laptops, medical equipment, and so on. Dioo's product families include analog signal processing and amplifying, LED drivers, and charger ICs. Go to <http://www.dioo.com> for a complete list of Dioo product families.

For additional product information or full datasheet, please contact our sales department or representatives.

dioo

Looking for pricing, stock, or lifecycle information?

Click below to explore more details on WIN SOURCE:

- ⊖ [View GD25D40CTIG on WIN SOURCE](#)
- ⊖ [GigaDevice Semiconductor Information](#)

Optimize Your Supply Chain with WIN SOURCE Solutions

- ✓ Global Sourcing Solution
- ✓ Obsolete Management
- ✓ Cost Control Management
- ✓ Shortage Management
- ✓ Alternative Solution
- ✓ Excess Inventory Management