

Compact and highly reliable type available in many varieties

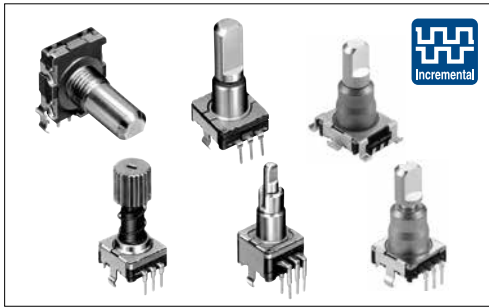

Typical Specifications

Items	Specifications
Output signal	Two phase of A, B Self-return switch (EC111 / EC11E0B)
Rating	10mA 5V DC
Operating life	15,000 cycles 100,000 cycles (EC11K / EC11J)
Operating temperature range	-40°C to +85°C

Product Line

Structure	Shaft configuration	Length of the shaft (mm)	Torque (mN·m)	Number of detent	Number of pulse	Push-on switch	Travel of push-on switch (mm)	Operating life (cycles)	Minimum order unit (pcs.)		Product No.	Drawing No.		
									Japan	Export				
Horizontal	Flat	20	12±7	30	15	Without	—	15,000	700	1,400	EC11B15202AN	1		
						With	0.5				EC11B15242AZ	2		
							1.5				EC11B15242B1	3		
Vertical	Flat	20	10±7	18	9	Without	—	15,000	1,200	2,400	EC11E09204A4	4		
				30	15						EC11E15204A3			
				36	18						EC11E1820402			
				18	9						EC11E09244BS			
				30	15						EC11E15244G1			
				7 ± ₋₄ ³							Without	EC11E153440D		
		10±7	36	With	0.5	EC11E18244AU	5							
		7 ± ₋₄ ³	Without			EC11E183440C								
		10±7	18			9					EC11E09244AQ			
		15	10±7	30	15	EC11E15244B2								
				7 ± ₋₄ ³		Without					EC11E1534408			
				10±7		36	EC11E18244A5							
		20	10±7	30	15	Without	1.5				EC11E1834403			
						7 ± ₋₄ ³					Without	EC11N1520401	6	
						Without					—	EC11N1524402	7	
25	12±7	30	15	With	1.5	EC11N1525404								
				8.5±5	Without	EC11N1520402	6							
				8.5±5	Without	EC11N1524403	7							
Less shaft wobble	Serrated	25	12±7	30	15	With		1.5	1,000	2,000	EC11G1560414	8		
							8.5±5				Without	EC11G1574402	9	
							8.5±5				Without	EC11G1564411	10	
							8.5±5				Without	EC11M1565403	9	
							8.5±5				Without	EC11M1575403	10	
Vertical	Flat	20	12±5	18	9	Without	—	100,000	1,000	2,000	EC11K0920404	11		
				30	15						EC11K1520406			
				18	9						With	0.5	EC11K0924404	
				30	15								EC11K1524406	12
				18	9								EC11K0925416	
				30	15								EC11K1525413	

Note
Other varieties are also available. Please inquire.

Refer to P.267 for attached parts.
Refer to P.268 for product varieties.
Refer to P.270 for switch specifications.
Refer to P.299 for soldering conditions.

Encoders
Metal Shaft
Insulated Shaft
Through Shaft Type
Ring Type

EC11 1 1 mm Size Metal Shaft Type

Product Line

Structure	Shaft configuration	Length of the shaft (mm)	Torque (mN·m)	Number of detent	Number of pulse	Push-on switch	Travel of push-on switch (mm)	Operating life (cycles)	Minimum order unit (pcs.)		Product No.	Drawing No.	
									Japan	Export			
Reflow	Flat	20	12±5 (Initial) 10±4 (After reflow)	18	9	Without	—	100,000	600	600	EC11J0920404	13	
											EC11J152040F		
						With	0.5				EC11J0924411	14	
											EC11J1524413		
							1.5				EC11J0925403		
											EC11J1525402		
Push lock	20-tooth Serrated	25	10±7	30	15	Without	—	15,000	800	1,600	EC11E152T409	15	
		26.4				With					8	EC11E152U402	16
Self-return switch	Flat	15	3 to 30	Without	Self-return switch	Without	—	15,000	1,200	2,400	EC1110120005	17	
		20				With					0.5	EC111012010H	18
						1.5					EC1110120201		
Dual-shaft	Slotted	Inner-shaft=25	10±7	30	15	Without	—	15,000	700	1,400	EC11EBB24C03	19	
		Outer-shaft=15				With					1.5	EC11E0B2LB01	20
	Flat	Inner-shaft=25	Without	—									
	Slotted	Outer-shaft=15	3 to 30	Without	Self-return switch	Without	—						

Note

Other varieties are also available. Please inquire.







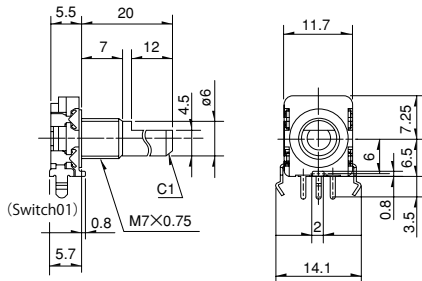
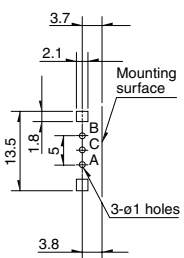

Packing Specifications

Tray

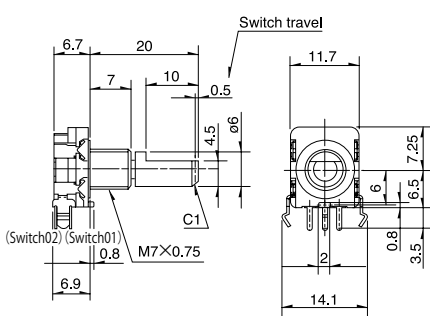
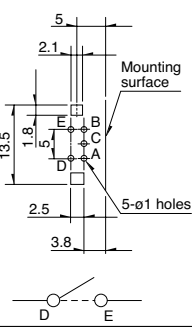
Product No.	Number of packages (pcs.)		Export package measurements (mm)
	1 case /Japan	1 case /export packing	
EC11B	700	1,400	524×374×201
EC11E09/15/18/EC11N	1,200	2,400	540×360×250
EC11G/EC11K/EC11M	1,000	2,000	
EC11J	600	600	369×283×263
EC11E152T/U	800	1,600	507×363×230
EC111	1,200	2,400	507×363×216
EC11E0B/BB	700	1,400	

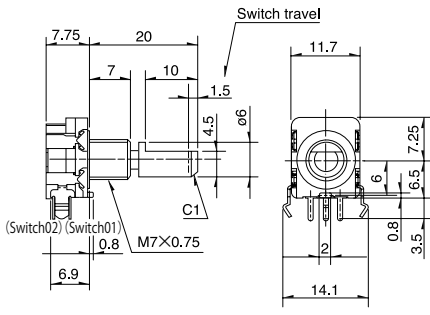
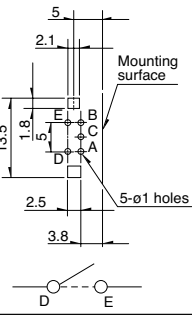
Refer to P.267 for attached parts.
 Refer to P.268 for product varieties.
 Refer to P.270 for switch specifications.
 Refer to P.299 for soldering conditions.

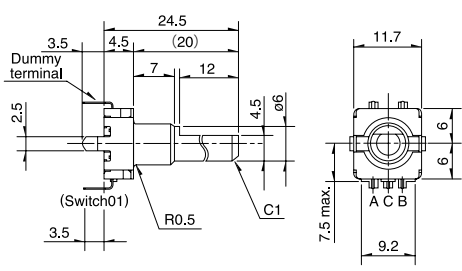
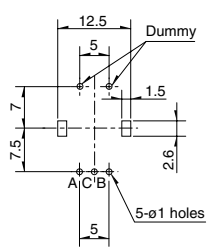
Dimensions

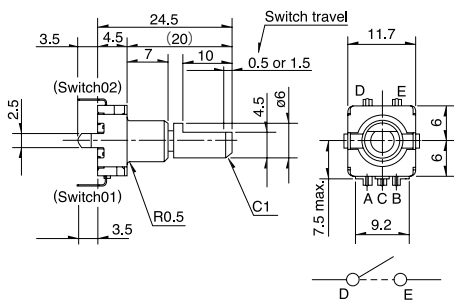
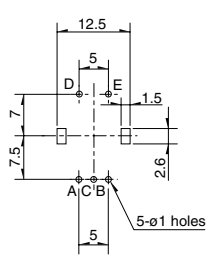
No.	Photo	Style	PC board mounting hole dimensions (Viewed from mounting side)
1	<p>EC11B Horizontal</p> 		
2	<p>EC11B Horizontal with push-on switch (travel 0.5mm)</p> 		
3	<p>EC11B Horizontal with push-on switch (travel 1.5mm)</p> 		
4	<p>EC11E Vertical</p> 		
5	<p>EC11E Vertical with push-on switch (travel 0.5mm / 1.5mm)</p> 		

Encoders

Metal Shaft

Insulated Shaft







Through Shaft Type

Ring Type

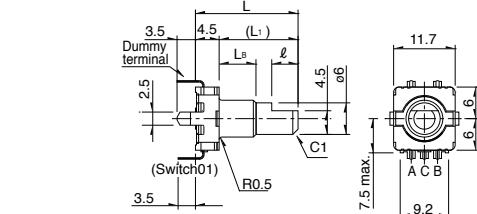
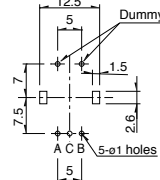
EC11 1.1 mm Size Metal Shaft Type

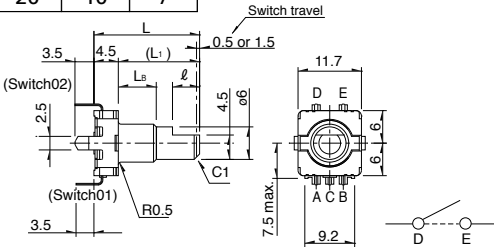
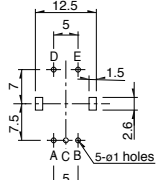

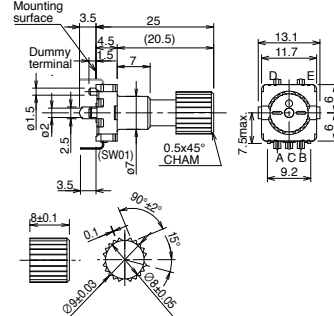
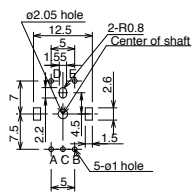

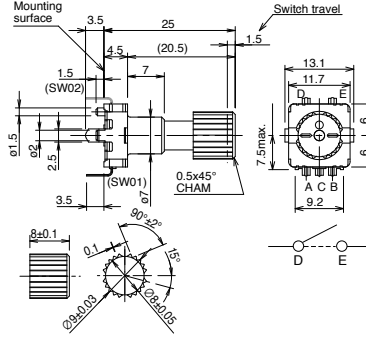
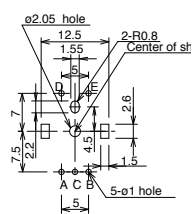
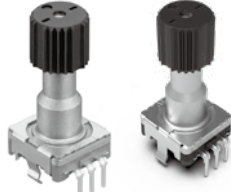
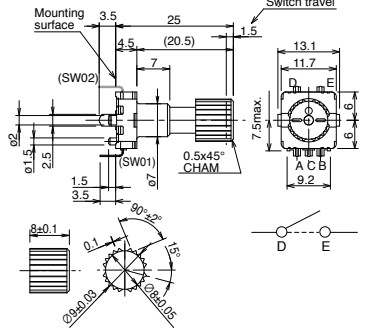
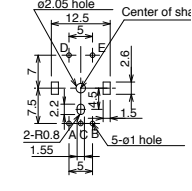

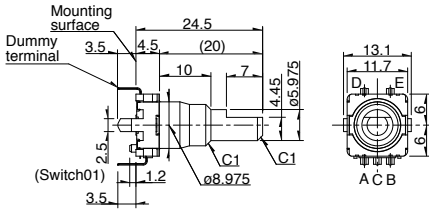
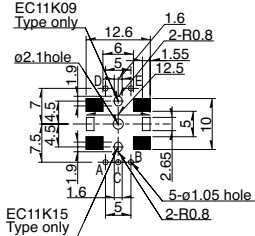

Dimensions

Unit:mm

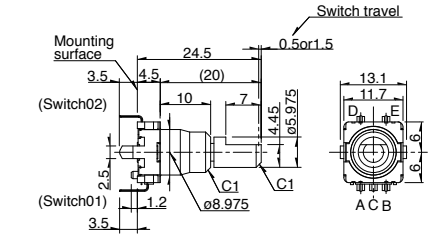
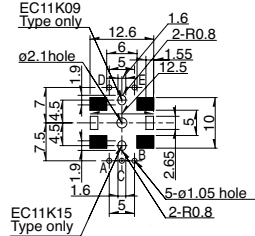
No.	Photo	Style	PC board mounting hole dimensions (Viewed from mounting side)												
6	<p>EC11N Vertical</p> 	<table border="1"> <thead> <tr> <th>L</th> <th>L₁</th> <th>L_B</th> <th>ℓ</th> </tr> </thead> <tbody> <tr> <td>19.5</td> <td>15</td> <td>7</td> <td>5</td> </tr> <tr> <td>24.5</td> <td>20</td> <td>10</td> <td>7</td> </tr> </tbody> </table> 	L	L ₁	L _B	ℓ	19.5	15	7	5	24.5	20	10	7	
L	L ₁	L _B	ℓ												
19.5	15	7	5												
24.5	20	10	7												
7	<p>EC11N Vertical with push-on switch (travel 0.5mm / 1.5mm)</p> 	<table border="1"> <thead> <tr> <th>L</th> <th>L₁</th> <th>L_B</th> <th>ℓ</th> </tr> </thead> <tbody> <tr> <td>19.5</td> <td>15</td> <td>7</td> <td>5</td> </tr> <tr> <td>24.5</td> <td>20</td> <td>10</td> <td>7</td> </tr> </tbody> </table> 	L	L ₁	L _B	ℓ	19.5	15	7	5	24.5	20	10	7	
L	L ₁	L _B	ℓ												
19.5	15	7	5												
24.5	20	10	7												
8	<p>EC11G Vertical</p> 														
9	<p>EC11G, EC11M Vertical with push-on switch (travel 1.5mm)</p>  <p>EC11G EC11M</p>														
10	<p>EC11G, EC11M Vertical with push-on switch (travel 1.5mm)</p>  <p>EC11G EC11M</p>														

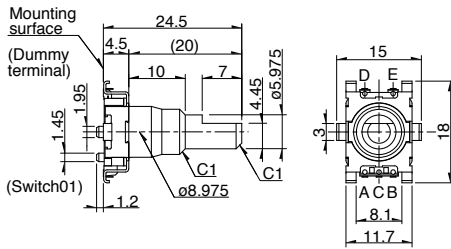
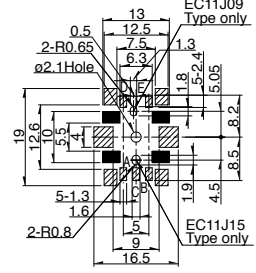
Dimensions

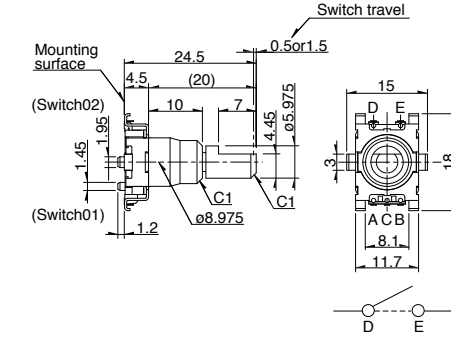
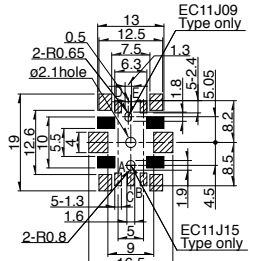
Unit:mm

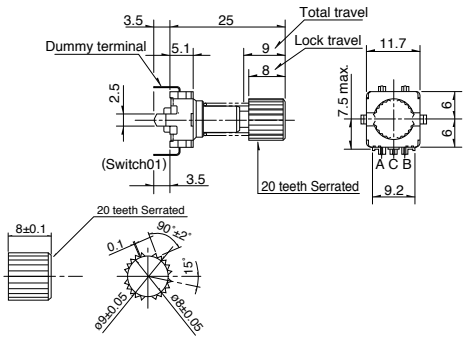
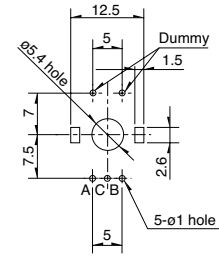
No.	Photo	形状	PC board mounting hole dimensions (Viewed from mounting side)
11			 <p>EC11K09 Type only</p> <p>EC11K15 Type only</p> <p>Black part : Do not solder and no wiring for electrical contact.</p>
12			 <p>EC11K09 Type only</p> <p>EC11K15 Type only</p> <p>Black part : Do not solder and no wiring for electrical contact.</p>
13			 <p>EC11J09 Type only</p> <p>EC11J15 Type only</p> <p>A slant line part: The solder land Black part: Do not solder and wiring for electrical contact</p>
14			 <p>EC11J09 Type only</p> <p>EC11J15 Type only</p> <p>A slant line part: The solder land Black part: Do not solder and wiring for electrical contact</p>
15			 <p>Dummy</p> <p>5-ø1 hole</p>

Encoders

Metal Shaft

Insulated Shaft







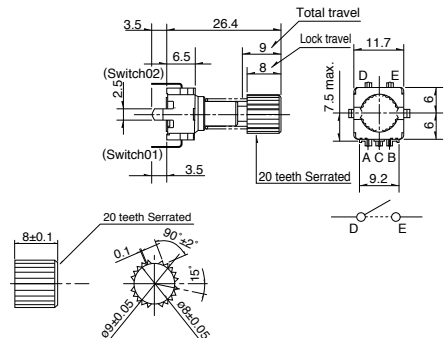
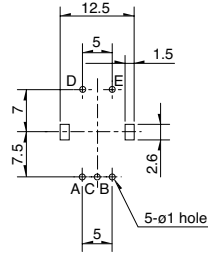

Through Shaft Type

Ring Type

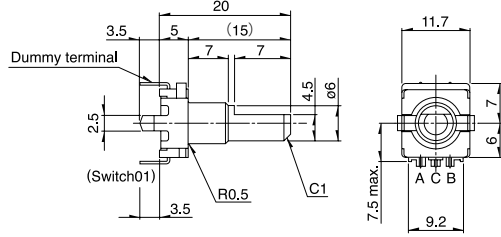
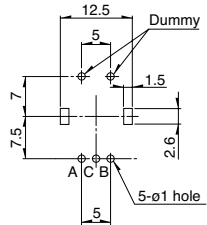
EC11 1.1 mm Size Metal Shaft Type

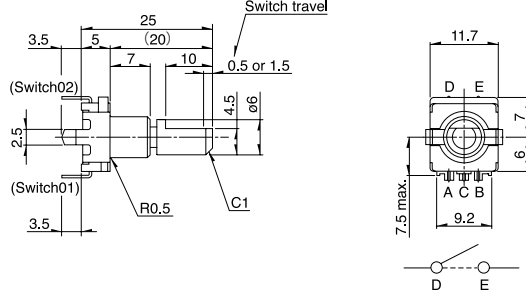
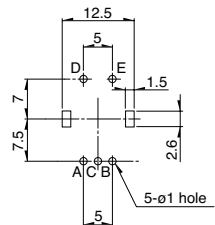
Dimensions

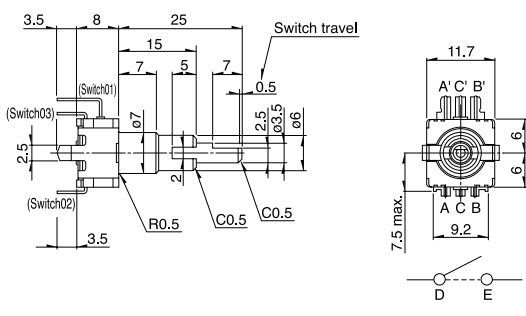
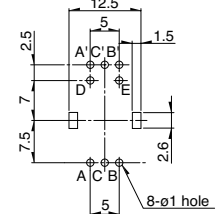
Unit:mm

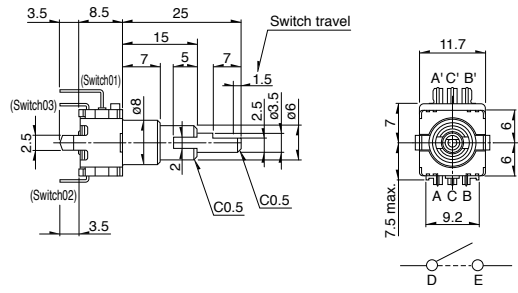
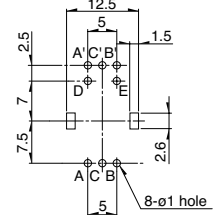
No.	Photo	Style	PC board mounting hole dimensions (Viewed from mounting side)
16	<p>EC11E152U Push-lock mechanism with push-lock switch</p> 		
17	<p>EC111 Self-return switch</p> 		
18	<p>EC111 Self-return switch with push-on switch (travel 0.5mm / 1.5mm)</p> 		
19	<p>EC11E Dual-shaft type with push-on switch (travel 0.5mm) Inner shaft: encoder Outer shaft: encoder</p> 		
20	<p>EC11E Dual-shaft type with push-on switch (travel 1.5mm) Inner shaft: encoder Outer shaft: self-return switch</p> 		

Encoders

Metal Shaft

Insulated Shaft

Through Shaft Type

Ring Type

Output Wave

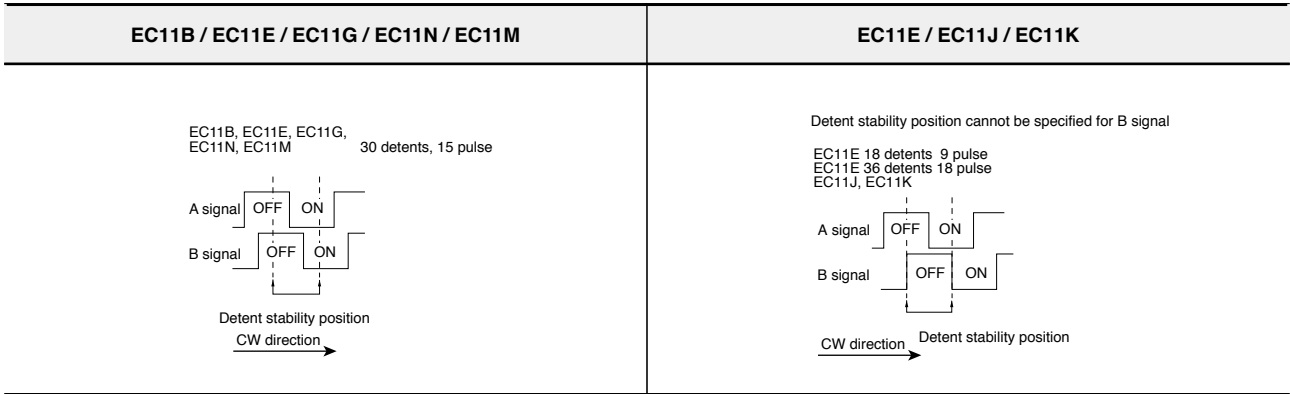

Sliding Noise

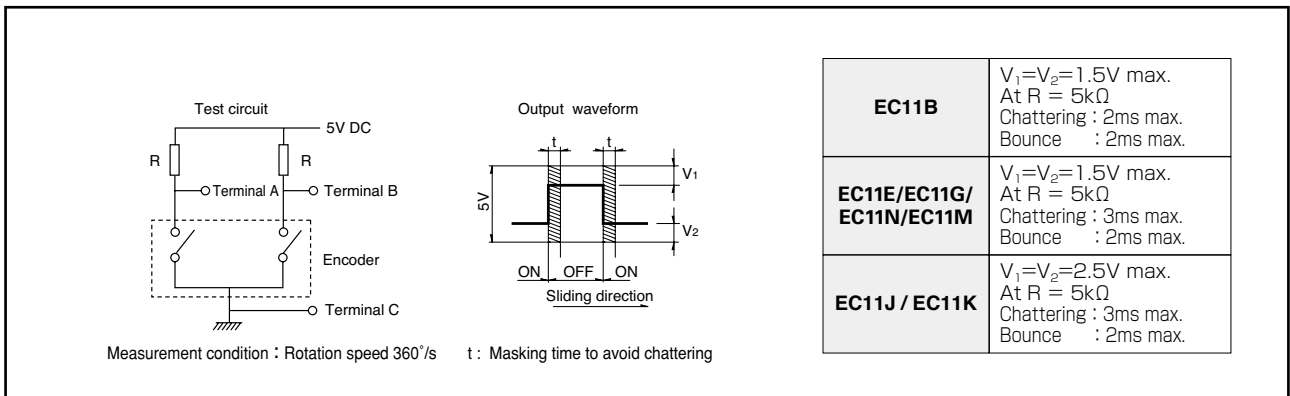

Circuit Diagram

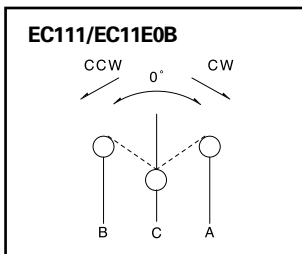

11mm Size Metal Shaft Type / Attached Parts

The following parts are included with the product.

EC11B Series

Unit:mm

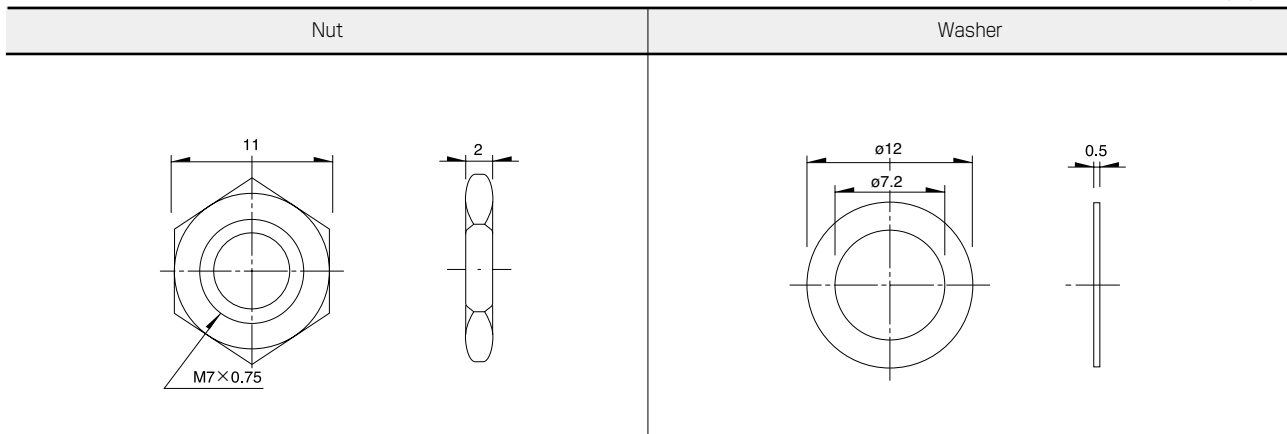

1 1 mm Size Metal Shaft Type / Product Varieties

Shaft Dimensions

1. Single-shaft Type

1) Serrated Type

Unit:mm

<p>EC11 Style (Shaft diameter: $\phi 6$) Not applicable for EC11E and EC11G with push-lock mechanism</p>	<p>$\phi 7$※ *M7 for EC11B.</p>	<p>● Detailed dimensions</p> <table border="1"> <thead> <tr> <th>L_1</th> <th>L_B</th> <th>l_1</th> <th>l_2</th> <th>S_1</th> </tr> </thead> <tbody> <tr> <td>20</td> <td>7</td> <td>6</td> <td>1</td> <td>7</td> </tr> <tr> <td>※ 25</td> <td>10</td> <td>10</td> <td>2</td> <td>11</td> </tr> </tbody> </table> <p>※$L_B=7$ for EC11B.</p>	L_1	L_B	l_1	l_2	S_1	20	7	6	1	7	※ 25	10	10	2	11
L_1	L_B	l_1	l_2	S_1													
20	7	6	1	7													
※ 25	10	10	2	11													
<p>EC11K / EC11J Style (Shaft diameter: $\phi 6$)</p>	<p>$\phi 6.975$</p>	<p>● Detailed dimensions</p> <table border="1"> <thead> <tr> <th>L_1</th> <th>L_B</th> <th>l_1</th> </tr> </thead> <tbody> <tr> <td>15</td> <td>7</td> <td>5</td> </tr> <tr> <td>20</td> <td>10</td> <td>6</td> </tr> </tbody> </table>	L_1	L_B	l_1	15	7	5	20	10	6						
L_1	L_B	l_1															
15	7	5															
20	10	6															
<p>EC11G Style (Shaft diameter: $\phi 9$)</p>	<p>$\phi 7$</p>	<p>● Detailed dimensions</p> <table border="1"> <thead> <tr> <th>L</th> <th>L_1</th> <th>L_B</th> </tr> </thead> <tbody> <tr> <td>18</td> <td>13.5</td> <td>5</td> </tr> <tr> <td>25</td> <td>20.5</td> <td>7</td> </tr> <tr> <td>28</td> <td>23.5</td> <td>10</td> </tr> </tbody> </table>	L	L_1	L_B	18	13.5	5	25	20.5	7	28	23.5	10			
L	L_1	L_B															
18	13.5	5															
25	20.5	7															
28	23.5	10															

2) Flat Type

Unit:mm

<p>EC11 Style (Shaft diameter: $\phi 6$)</p>	<p>$\phi 7$</p> <p>*M7 for EC11B.</p>	<p>● Detailed dimensions</p> <table border="1"> <thead> <tr> <th>L_1</th> <th>L_B</th> <th>l</th> </tr> </thead> <tbody> <tr> <td>※1 15</td> <td>5</td> <td>7</td> </tr> <tr> <td>15</td> <td>7</td> <td>5 (6)</td> </tr> <tr> <td>20</td> <td>7</td> <td>10 (12)</td> </tr> <tr> <td>※2 25</td> <td>10</td> <td>12</td> </tr> </tbody> </table> <p>※1 Does not comply with EC111 ※2 $L_B=7$ for EC11B. Values in parentheses apply to products without push-on switch.</p>	L_1	L_B	l	※1 15	5	7	15	7	5 (6)	20	7	10 (12)	※2 25	10	12
L_1	L_B	l															
※1 15	5	7															
15	7	5 (6)															
20	7	10 (12)															
※2 25	10	12															
<p>EC11K / EC11J Style (Shaft diameter: $\phi 5.975$)</p>	<p>$\phi 5.975$</p> <p>$\phi 8.975$</p>	<p>● Detailed dimensions</p> <table border="1"> <thead> <tr> <th>L_1</th> <th>L_B</th> <th>l</th> </tr> </thead> <tbody> <tr> <td>15</td> <td>7</td> <td>5</td> </tr> <tr> <td>20</td> <td>10</td> <td>7</td> </tr> </tbody> </table>	L_1	L_B	l	15	7	5	20	10	7						
L_1	L_B	l															
15	7	5															
20	10	7															

Notes

- The highlighted figures in shaft types refer to Product Specifications in P.261 and P.262.
- Other varieties are also available. Please inquire.

1 1 mm Size Metal Shaft Type / Product Varieties

Shaft Dimensions

1. Single-shaft Type

3) Slotted Type

Unit:mm

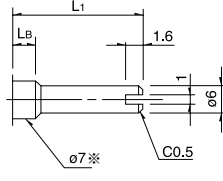
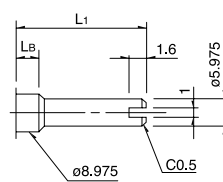
<p>EC11 Style (Shaft diameter : $\phi 6$)</p>  <p>$\phi 7$※ ※M7 for EC11B.</p>	<p>● Detailed dimensions</p> <table border="1" data-bbox="989 347 1404 481"> <thead> <tr> <th>L_1</th> <th>L_B</th> </tr> </thead> <tbody> <tr> <td>15</td> <td>7</td> </tr> <tr> <td>20</td> <td>7</td> </tr> <tr> <td>25</td> <td>10</td> </tr> </tbody> </table> <p>※ ※$L_B=7$ for EC11B</p>	L_1	L_B	15	7	20	7	25	10
L_1	L_B								
15	7								
20	7								
25	10								
<p>EC11K / EC11J Style (Shaft diameter : $\phi 5.975$)</p>  <p>$\phi 8.975$ ※M7 for EC11B.</p>	<p>● Detailed dimensions</p> <table border="1" data-bbox="989 571 1404 660"> <thead> <tr> <th>L_1</th> <th>L_B</th> </tr> </thead> <tbody> <tr> <td>15</td> <td>7</td> </tr> <tr> <td>20</td> <td>10</td> </tr> </tbody> </table>	L_1	L_B	15	7	20	10		
L_1	L_B								
15	7								
20	10								

2. Standard Dimensions and Configuration of Dual-shaft Type

Flat Type

Unit:mm

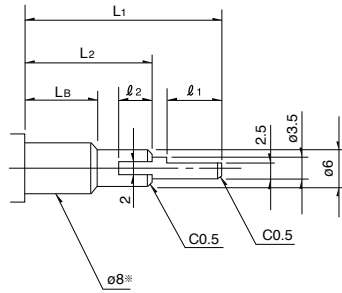
<p>EC11E Style (Inner-shaft : $\phi 3.5$ Outer-shaft : $\phi 6$)</p>  <p>$\phi 8$※ ※ $\phi 7$ for type with inner / outer shaft encoders (EC11EBB)</p>	<p>● Detailed dimensions</p> <table border="1" data-bbox="981 929 1404 1064"> <thead> <tr> <th>L_1</th> <th>L_2</th> <th>L_B</th> <th>l_1</th> <th>l_2</th> </tr> </thead> <tbody> <tr> <td>20</td> <td>10</td> <td>5</td> <td>7</td> <td>4</td> </tr> <tr> <td>25</td> <td>15</td> <td>7</td> <td>7</td> <td>5</td> </tr> <tr> <td>30</td> <td>20</td> <td>10</td> <td>7</td> <td>5</td> </tr> </tbody> </table>	L_1	L_2	L_B	l_1	l_2	20	10	5	7	4	25	15	7	7	5	30	20	10	7	5
L_1	L_2	L_B	l_1	l_2																	
20	10	5	7	4																	
25	15	7	7	5																	
30	20	10	7	5																	

Notes

- The highlighted figures in shaft types refer to Product Specifications in P.261 and P.262.
- Other varieties are also available. Please inquire.

1 mm Size Metal Shaft Type / Switch Specifications

1. EC11B Series

Switch type		Momentary push switch	
Contact arrangement		Single pole and single throw (Push-on)	
Travel (mm)		$0.5 \begin{smallmatrix} +0.4 \\ -0.3 \end{smallmatrix}$	1.5 ± 0.5
Operating force		$6 \pm 3\text{N}$	$5 \pm 2\text{N}$
Operating life		25,000 times	20,000 times
Electrical performance	Rating	0.1A 5V DC (500 μ A 5V DC min. ratings)	
	Contact resistance	100m Ω max. for initial period, 200m Ω max. after operating life.	
	Insulation resistance	100M Ω min. 250V DC	
	Voltage proof	300V AC for 1 minute or 360V AC for 2 second	

2. EC11E/EC11N/EC11I Series

Switch type		Momentary push switch	
Contact arrangement		Single pole and single throw (Push-on)	
Travel (mm)		0.5 ± 0.3	1.5 ± 0.5
Operating force		$6 \begin{smallmatrix} +2.5 \\ -2 \end{smallmatrix}\text{N}$	$4 \pm 2\text{N}$
Operating life		20,000 times	
Electrical performance	Rating	0.1A 5V DC (500 μ A 5V DC min. ratings)	
	Contact resistance	100m Ω max. for initial period, 200m Ω max. after operating life.	
	Insulation resistance	100M Ω min. 250V DC	
	Voltage proof	300V AC for 1 minute or 360V AC for 2 second	

3. EC11G/EC11M Series

Switch type		Momentary push switch	
Contact arrangement		Single pole and single throw (Push-on)	
Travel (mm)		1.5 ± 0.35	
Operating force		$5 \pm 2\text{N}$	
Operating life		20,000 times	
Electrical performance	Rating	0.15A 5V DC (500 μ A 5V DC min. ratings)	
	Contact resistance	100m Ω max. for initial period, 200m Ω max. after operating life.	
	Insulation resistance	100M Ω min. 250V DC	
	Voltage proof	300V AC for 1 minute or 360V AC for 2 second	

4. EC11K/EC11J Series











Switch type		Momentary push switch	
Contact arrangement		Single pole and single throw (Push-on)	
Travel (mm)		0.5 ± 0.3	1.5 ± 0.5
Operating force		$5 \pm 2\text{N}$	$4 \pm 2\text{N}$
Operating life		1,000,000 times	100,000 times
Electrical performance	Rating	0.1A 5V DC (0.1mA 5V DC min. ratings)	
	Contact resistance	100m Ω max. for initial period, 200m Ω max. after operating life.	
	Insulation resistance	100M Ω min. 250V DC	
	Voltage proof	300V AC for 1 minute or 360V AC for 1 second	

5. EC11E152U Series

Switch type		Push lock mechanism switch	
Contact arrangement		Single pole and single throw (Push-on)	
Travel (mm)		8 ± 0.8	
Operating force		8N max.	
Operating life		10,000 times	
Electrical performance	Rating	0.1A 5V DC (500 μ A 5V DC min. ratings)	
	Contact resistance	100m Ω max. for initial period, 200m Ω max. after operating life.	
	Insulation resistance	100M Ω min. 250V DC	
	Voltage proof	300V AC for 1 minute or 360V AC for 2 second	

Encoders

List of Varieties

Type		Metal shaft													
		9mm size				11mm size									
Series		EC09E		EC11B		EC11E				EC11N					
Photo															
Output		Incremental (Two phase A and B)													
Shaft types		Single-shaft						Dual-shaft			Single-shaft				
Operating direction		Vertical		Horizontal		Vertical									
Number of pulse / Number of detent		15/30				9/18 15/30 or without 18/36 or without				15/30					
Features		—		—		Without detent Push-lock mechanism				—		—			
Dimensions (mm)		W		9.5		11.7									
		D		13.75		12									
		H		4.5		5.5/6.7/7.75		4.5		8/8.5		4.5			
Operating temperature range		-40°C to +85°C													
Operating life		15,000 cycles													
Automotive use		●		●		●				●					
Life cycle (availability)															
Electrical performance		Rating		10mA 5V DC											
		Max./min. operating current (Resistive load)		10mA /1mA											
		Insulation resistance		100MΩ min. 250V DC											
		Voltage proof		300V AC for 1 minute or 360V AC for 1s		300V AC for 1 minute or 360V AC for 2s									
Mechanical performance		Rotational torque (Without detent)		—		—		7 ± 3mN·m		—		—			
		Detent torque		8 ± 5mN·m		12 ± 7mN·m		10 ± 7mN·m							
		Push-pull strength		100N											
Shaft configuration		Flat		Flat, Slotted, Serrated				Inner-shaft : Flat Outer-shaft : Slotted		Flat					
Terminal type		Insertion													
Switch Specifications		Switch type		Push-on switch						Push-lock mechanism switch ※		Push-on switch			
		Contact arrangement		Single pole and single throw (Push-on)											
		Travel (mm)		0.5 ± 0.3	1.5 ± 0.5	0.5 ± 0.4 0.3	1.5 ± 0.5	0.5 ± 0.3	1.5 ± 0.5	8 ± 0.8	0.5 ± 0.3	1.5 ± 0.5	0.5 ± 0.3	1.5 ± 0.5	
		Operating force (N)		6 ± 2.5 2	4 ± 2	6 ± 3	5 ± 2	6 ± 2.5 2	4 ± 2	8 max.	6 ± 2.5 2	4 ± 2	6 ± 2.5 2	4 ± 2	
		Rating		10mA 5V DC (1mA 5V DC min. ratings)		0.1A 5V DC (500μA 5V DC min. ratings)									
		Contact resistance		100mΩ max. for initial period; 200mΩ max. after operating life.											
		Operating life		10,000 times		25,000 times		20,000 times		10,000 times		20,000 times			
Page		259				261									













Encoders Soldering Conditions	299
Encoders Cautions	300

Notes

- ※marked specification is only applicable to EC11E152U402.
- Indicates applicability to all products in the series.

Encoders

List of Varieties

Type		Metal shaft								
		11mm size								
Series		EC11G	EC11M	EC111	EC11K	EC11J	EM11B			
Photo										
Output		Incremental (Two phase A and B)		Self-return switch	Incremental (Two phase A and B)					
Shaft types		Single-shaft								
Operating direction		Vertical								
Number of pulse / Number of detent		15/30 15/without		—	9/18 15/30		16/16			
Features		Less shaft wobble		—	—	Surface Mount type		Magnetic type		
Dimensions (mm)	W	11.7						10.8		
	D	12	13	12	15.3		11			
	H	4.5	5	4.5		7.5				
Operating temperature range		-40°C to +85°C						-30°C to +85°C		
Operating life		15,000 cycles			100,000 cycles			1,000,000 cycles		
Automotive use		●	●	●	●	●	●	●		
Life cycle (availability)										
Electrical performance	Rating	10mA 5V DC						10mA 5V±5% DC		
	Max./min. operating current (Resistive load)	10mA / 1mA						15mA / —		
	Insulation resistance	100MΩ min. 250V DC						100MΩ min. 100V DC		
	Voltage proof	300V AC for 1 minute or 360V AC for 2s			300V AC for 1 minute or 360V AC for 1s			250V AC for 1 minute or 300V AC for 2s		
Mechanical performance	Rotational torque (Without detent)	8.5±5mN·m		3 to 30mN·m		—	—	—		
	Detent torque	12±7mN·m		—	12±5mN·m		12±5mN·m (Initial) 10±4mN·m (After reflow)		10±5mN·m	
	Push-pull strength	100N								
Shaft configuration		Serrated		Flat, Slotted, Serrated				Flat		
Terminal type		Insertion					Reflow		Insertion	
Switch Specifications	Switch type	Push-on switch								
	Contact arrangement	Single pole and single throw (Push-on)								
	Travel (mm)	1.5±0.35		0.5±0.3	1.5±0.5	0.5±0.3	1.5±0.5	0.5±0.3	1.5±0.5	0.5 ± _{0.2} ^{0.3}
	Operating force (N)	5±2		6 ± ₂ ^{2.5}	4±2	5±2	4±2	5±2	4±2	5.5±3
	Rating	0.1A 5V DC (500μA 5V DC min. ratings)				0.1A 5V DC (0.1mA 5V DC min. ratings)			5mA 5V DC (50mA 12V DC max. ratings)	
	Contact resistance	100mΩ max. for initial period, 200mΩ max. after operating life.						500mΩ max. for initial period, 5mΩ max. after operating life.		
	Operating life	20,000 times				1,000,000 times	100,000 times	1,000,000 times	100,000 times	1,000,000 times
Page		261						271		

Encoders Soldering Conditions	299
Encoders Cautions	300

Note

- Indicates applicability to all products in the series.

Reference for Manual Soldering

Series	Tip temperature	Soldering time	No. of solders
EC05E, EC09E, EC10E, EC111, EC11B, EC11E, EC11G, EC11K, EC11M, EC11N, EC12D, EC12E, EC18A, EC21A, EC28A, EC35A, EC35AH, EC40A, EC45A, EC50A, EC60B, EM11B, EC21C, EC28C, EC35CH	350°C max.	3s max.	1 time
EC11J	350±10°C	3 ⁺¹ ₀ s	2 times

Reference for Dip Soldering

Series	Preheating		Dip soldering		No. of solders
	Soldering surface temperature	Heating time	Soldering temperature	Soldering time	
EC09E, EC11B, EC111, EC11E, EC11G, EC11K, EC11M, EC11N, EC18A, EC21A, EC28A, EC35A, EC35AH, EC50A, EC60B	100°C max.	2 min. max.	260±5°C	5±1s	2 times max.
EM11B	100°C max.	1 min. max.	260°C max.	3s max.	2 times max.
EC10E, EC12D, EC12E	100°C max.	1 min. max.	260±5°C	3±1s	2 times max.
EC40A	110°C max.	1 min. max.	260°C max.	10s max.	1 time
EC45A	100°C max.	2 min. max.	260°C max.	5s max.	2 times max.

Example of Reflow Soldering Condition

Temperature profile

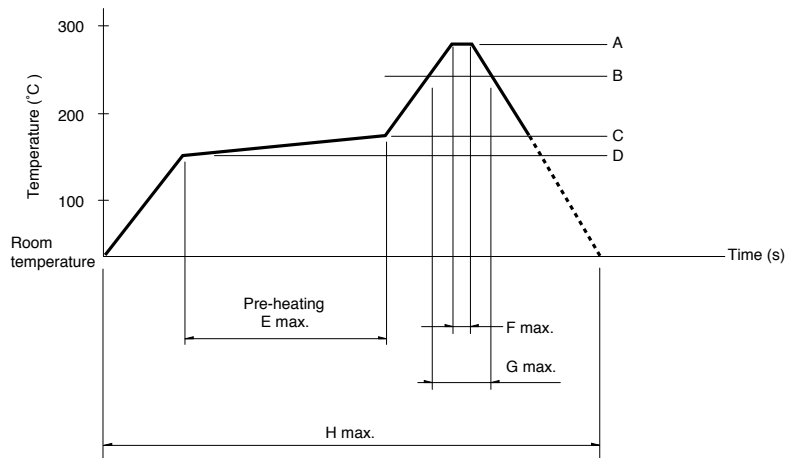



Series	A	B	C	D	E	F	G	H	No. of reflows
EC11J	260°C	230°C	180°C	150°C	2 min. max.	3s	40s	4 min. max.	2 times max.
EC05E	250°C min.	230°C min.	180°C	150°C	60s to 120s	—	30s to 40s	—	2 times max.
EC21C	230°C to 245°C	220°C	200°C	150°C	60s to 120s	—	25s to 60s	300s max.	1 time max.
EC28C, EC35CH	260°C	230°C	180°C	150°C	2 min. min.	3s	40s	230s max.	1 time max.

Notes

- When using an infrared reflow oven, solder may sometimes not be applied. Be sure to use a hot air reflow oven or a type that uses infrared rays in combination with hot air.
- The temperatures given above are the maximum temperatures at the terminals of the encoder when employing a hot air reflow method. The temperature of the PC board and the surface temperature of the encoder may vary greatly depending on the PC board material, its size and thickness. Ensure that the surface temperature of the encoder does not rise to 250°C or greater.
- Conditions vary to some extent depending on the type of reflow bath used. Be sure to give due consideration to this prior to use.

Looking for pricing, stock, or lifecycle information?

Click below to explore more details on WIN SOURCE:

-  [View EC11M1565403 on WIN SOURCE](#)
-  [Alps Alpine Information](#)

Optimize Your Supply Chain with WIN SOURCE Solutions

-  Global Sourcing Solution
-  Obsolete Management
-  Cost Control Management
-  Shortage Management
-  Alternative Solution
-  Excess Inventory Management