

Sub-1GHz 6LoWPAN Network Processor

Accelerate your 6LoWPAN Development

Applications

- Large scale mesh networks that require IP backbone interconnectivity
- Automated Meter Reading
- Street Lighting Systems
- Home/Building automation
- Industrial control and monitoring
- Mesh sensor networks

Product Description

The **CC1180** is a cost-effective, low power, sub-1GHz 6LoWPAN Network Processor that provides 6LoWPAN functionality with a minimal development effort.

The **CC1180** is a preloaded version of **CC1110F32**, where TI third party Sensinode's 6LoWPAN stack, NanoStack 2.0 Lite, runs on the **CC1180** Network Processor. The application controlling the Network Processor runs on an external host microcontroller. The **CC1180** handles all the timing critical and processing intensive 6LoWPAN protocol tasks, and leaves the resources of the application microcontroller free to handle the application.

CC1180 makes it easy to add 6LoWPAN functionality to new or existing products at the same time as it provides great flexibility in choice of microcontroller. How to use Sensinode NanoStack 2.0 is described in the User's Guide SWRU298.pdf.

CC1180 interfaces almost any microcontroller through a UART interface; **CC1180** can e.g. be combined with an MSP430.

The **CC1180** contains a bootloader, Sensinode NanoBoot. The bootloader is used to download the Sensinode 6LoWPAN stack, NanoStack 2.0 Lite.

CC1180 supports Sensinode's simple NAP protocol API. The NAP Protocol API has only a small amount of API calls to learn, which drastically simplifies the development of 6LoWPAN applications. The API has a socket like approach, to enable easy and fast integration between the host and network processor.

CC1180 comes preloaded with Sensinode NanoBoot and a TI IEEE EUID (MAC address); the MAC address can be read and written using NanoBoot.

Key Features

- Simple integration of 6LoWPAN with mesh support into any design
- Running Sensinode's mature and stable 6LoWPAN mesh stack, NanoStack 2.0 Lite
- UART interface to microcontroller running the application
- Supports updating of the NanoStack 2.0 Lite 6LoWPAN stack using Sensinode NanoBoot API. Over-The-Air updates are supported, provided that the host microcontroller has enough memory to store the new stack image.
- Example 6LoWPAN mesh system overview
- Radio features:
 - 315/433/868/915 MHz ISM/SRD bands
 - Output power: -30dBm to +10dBm
 - Data rates: 50, 100, 150 and 200kbps
 - AES-CCM* secured IEEE802.15.4e payloads, using network-wide key.
 - Excellent receiver sensitivity and best in class robustness to interferers
- Power Supply
 - Wide supply voltage range (2.0V – 3.6V)
 - Low current consumption
- External System
 - Very few external components
- RoHS compliant 6x6 mm QFN 36 package

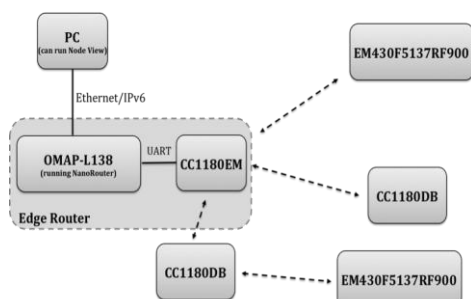

Note: Erasing the chip will result in having a blank device, with no possible way to recover the Sensinode NanoBoot.

Table of Contents

| | |
|---|-----------|
| APPLICATIONS | 1 |
| PRODUCT DESCRIPTION | 1 |
| KEY FEATURES | 1 |
| TABLE OF CONTENTS | 2 |
| ABBREVIATIONS | 3 |
| 1 ELECTRICAL CHARACTERISTICS | 4 |
| 2 PIN AND I/O PORT CONFIGURATION | 4 |
| 3 APPLICATION CIRCUIT | 6 |
| 4 SENSINODE NANOBOOT API | 7 |
| 4.1 INTRODUCTION | 7 |
| 4.2 OVERVIEW | 7 |
| 4.3 NANOBOOT PROTOCOL | 7 |
| 4.4 API COMMANDS | 8 |
| 4.5 STATE MACHINE | 9 |
| 4.6 SOFTWARE UPDATE PROCESS | 10 |
| 5 DEBUG INTERFACE | 12 |
| 6 DEVELOPMENT KIT ORDERING INFORMATION | 13 |
| 7 REFERENCES | 13 |
| 8 GENERAL INFORMATION | 13 |
| 8.1 DOCUMENT HISTORY | 13 |

Abbreviations

| | | | |
|-------|---|-------|---|
| AES | Advanced Encryption Standard | LQI | Link Quality Indicator |
| API | Application Programming Interface | LSB | Least Significant Byte |
| ARIB | Association of Radio Industries and Businesses | MAC | Medium Access Control |
| BOM | Bill of Materials | MSB | Most Significant Byte |
| CFR | Code of Federal Regulations | NA | Not Available |
| CPU | Central Processing Unit | NC | Not Connected |
| CRC | Cyclic Redundancy Check | PA | Power Amplifier |
| DC | Direct Current | PCB | Printed Circuit Board |
| EM | Evaluation Module | PER | Packet Error Rate |
| ESD | Electro Static Discharge | PHY | Physical Layer |
| ETSI | European Telecommunications Standards Institute | RAM | Random Access Memory |
| FCC | Federal Communications Commission | RF | Radio Frequency |
| FCS | Frame Check Sequence | RoHS | Restriction on Hazardous Substances |
| I/O | Input / Output | RSSI | Received Signal Strength Indicator |
| IEEE | Institute of Electrical and Electronics Engineers | RX | Receive |
| ISM | Industrial, Scientific and Medical | TBD | To Be Decided / To Be Defined |
| JEDEC | Joint Electron Device Engineering Council | TI | Texas Instruments |
| kB | 1024 bytes | TX | Transmit |
| kbps | kilobits per second | UART | Universal Asynchronous Receiver/Transmitter |
| | | USART | Universal Synchronous/Asynchronous Receiver/Transmitter |

1 Electrical Characteristics

For Electrical Characteristics tables, see SWRS033.pdf.

2 Pin and I/O Port Configuration

The **CC1180** has the exact same pinout as **CC1110F32** and is shown in Figure 1 and Table 1.

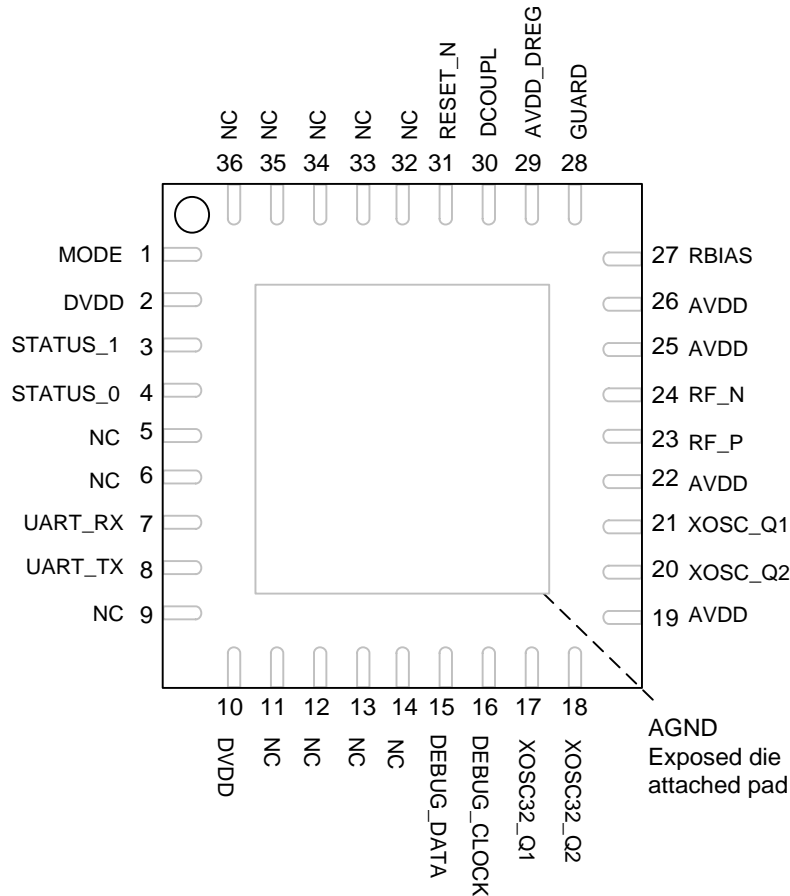

Figure 1: Pinout top view

Note: The exposed die attach pad **must** be connected to a solid ground plane as this is the ground connection for the chip.

| Pin | Pin name | Pin type | Description |
|-----|-------------|------------------|---|
| - | GND | Ground | The exposed die attach pad must be connected to a solid ground plane |
| 1 | MODE | Digital Input | CC1180 Input, connection with host MCU to control application or bootloader mode [2]. Must be high by default. Falling edge toggles mode. |
| 2 | DVDD | Power (Digital) | 2.0V-3.6V digital power supply for digital I/O |
| 3 | STATUS_1 | Digital Output | CC1180 Output, can be connected to e.g. LED to indicate application / bootloader mode [2]. |
| 4 | STATUS_0 | Digital Output | CC1180 Output, can be connected to e.g. LED to indicate application / bootloader mode [2]. |
| 5 | NC | D I/O | NC |
| 6 | NC | D I/O | NC |
| 7 | UART_RX | Digital Input | CC1180 USART0 RX Input, connection to host MCU [2]. |
| 8 | UART_TX | Digital Output | CC1180 USART0 TX Output, connection to host MCU [2]. |
| 9 | NC | D I/O | NC |
| 10 | DVDD | Power (Digital) | 2.0V-3.6V digital power supply for digital I/O |
| 11 | NC | D I/O | NC |
| 12 | NC | D I/O | NC |
| 13 | NC | D I/O | NC |
| 14 | NC | D I/O | NC |
| 15 | DEBUG_DATA | D I/O | Debug Data |
| 16 | DEBUG_CLOCK | D I/O | Debug Clock |
| 17 | XOSC32_Q1 | D I/O | 32.768 kHz crystal oscillator pin 1 |
| 18 | XOSC32_Q2 | D I/O | 32.768 kHz crystal oscillator pin 2 |
| 19 | AVDD | Power (Analog) | 2.0V-3.6V analog power supply connection |
| 20 | XOSC_Q2 | Analog I/O | 26 MHz crystal oscillator pin 2 |
| 21 | XOSC_Q1 | Analog I/O | 26 MHz crystal oscillator pin 1, or external clock input |
| 22 | AVDD | Power (Analog) | 2.0V-3.6V analog power supply connection |
| 23 | RF_P | RF I/O | Positive RF input signal to LNA in receive mode Positive RF output signal from PA in transmit mode |
| 24 | RF_N | RF I/O | Negative RF input signal to LNA in receive mode Negative RF output signal from PA in transmit mode |
| 25 | AVDD | Power (Analog) | 2.0V-3.6V analog power supply connection |
| 26 | AVDD | Power (Analog) | 2.0V-3.6V analog power supply connection |
| 27 | RBIAS | Analog I/O | External precision bias resistor for reference current |
| 28 | GUARD | Power (Digital) | Power supply connection for digital noise isolation |
| 29 | AVDD_DREG | Power (Digital) | 2.0V-3.6V digital power supply for digital core voltage regulator |
| 30 | DCOUP | Power decoupling | 1.8V digital power supply decoupling |
| 31 | RESET_N | DI | Reset, active low |
| 32 | NC | D I/O | NC |
| 33 | NC | D I/O | NC |
| 34 | NC | D I/O | NC |
| 35 | NC | D I/O | NC |
| 36 | NC | D I/O | NC |

Table 1: Pinout overview

3 Application Circuit

Since **CC1180** is a preloaded version of **CC110F32**, the application circuit for **CC1180** can be found in [1].

Figure 2 shows the software architecture for an application circuit where the **CC1180** network processor is controlled from a host MCU.

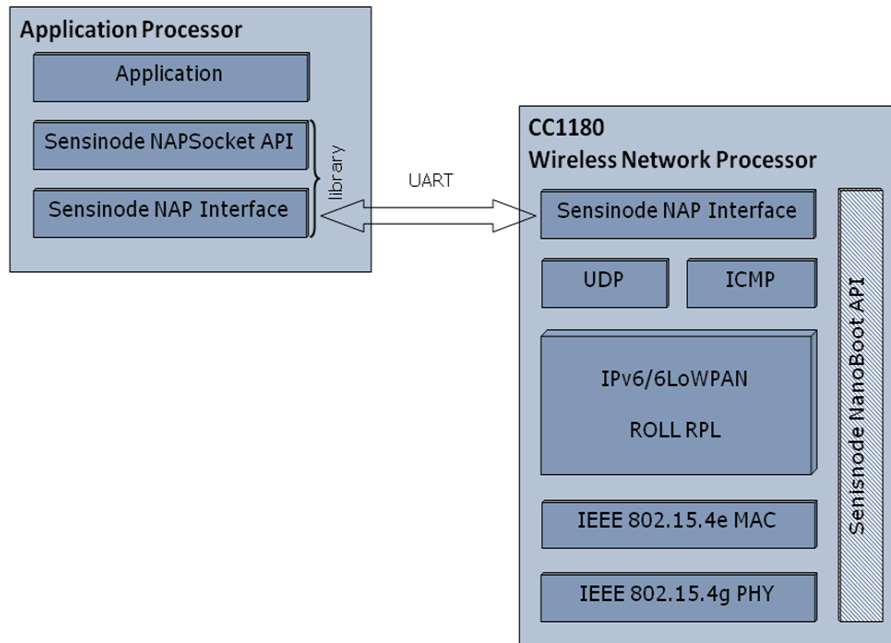

Figure 2. CC1180 based 6LoWPAN System

4 Sensinode NanoBoot API

4.1 Introduction

This section contains protocol description of Sensinode NanoBoot – the NanoStack 2.0 Lite bootloader. NanoBoot is a separate software component that can be used to update the 6LoWPAN stack firmware installed in flash. The Sensinode NanoStack 2.0 Lite stack firmware is encrypted; it is not possible to download stack firmware not verified by Sensinode. The use of bootloader requires the device that uploads the new flash image (i.e. the host) to implement the host part of the bootloader protocol.

4.2 Overview

NanoBoot is installed into flash address 0x0000. When the **CC1180** device is powered up, the bootloader is initialized. Depending on the contents of the flash memory at address 0x6FF7 the software will remain in bootloader mode or the Sensinode NanoStack 2.0 Lite 6LoWPAN stack will be executed. The Bootloader will remain active if the byte value is 0xFF, while value 0x00 will cause the 6LoWPAN stack to start executing.

The Bootloader requires a total of 5kB of flash memory. **CC1180** has 32kB of flash in total, thus 27kB of flash memory is available for the NanoStack 2.0 Lite 6LoWPAN stack. Available RAM is not affected.

The MAC address of **CC1180** is stored at flash address 0x6FF8 and is 8 bytes long.

4.2.1 Changing Application Mode

Before the application MCU can communicate with the NanoBoot module on the **CC1180** the module must be enabled properly. This is done by pulling **CC1180**MODE signal down to ground (0 volts); this causes a falling edge interrupt to occur. The NanoBoot mode is toggled on each falling edge of the MODE signal. The currently active mode can be identified from the state of the STATUS_0 (pin 4) and STATUS_1 (pin 3) pins. When STATUS_0 and STATUS_1 are constantly high, the **CC1180** device is in bootloader mode. See [2] for details.

4.3 NanoBoot Protocol

The Sensinode NanoBoot protocol has been designed to be an easy-to-parse, low-overhead serial protocol that has enough flexibility and extensibility for the NanoBoot bootloader. Low complexity has been an important design goal so that the protocol can be efficiently parsed even on MCUs with very limited resources. The potentially limited serial port data rates have imposed the need for a very low overhead compared to the actual payload data. Each packet of bootloader protocol is a NAP configuration packet with a special control byte (CT). This allows the application MCU to use the same NAP protocol implementation for all communication with the **CC1180** device. See [2] for more details on the Sensinode NAP Protocol.

The high level packet format is described in Table 2.

| Byte | 1 | 2 | 3 | 4 | 5 | ... | N |
|------|--------|-----|-----|----|--------|------------|----|
| Name | Length | 'N' | 'A' | CT | cmd_id | [Variable] | CS |

Table 2. High level NAP packet format

4.3.1 Length Byte

The first byte of a packet is **always** the total length of the packet **not including** the length byte itself but **including** the last byte (**CS**). The byte is in normal host order *i.e.* MSB.

4.3.2 Header Bytes

The two bytes following the Length byte are ASCII characters 'N' and 'A' (0x4e and 0x41 respectively). The two bytes are static and present in all packets. Wrong bytes will result in that NanoBoot discards the packet.

4.3.3 CT Byte

The Sensinode NAP protocol specifies a control (CT) byte to separate control and data messages as well as used protocol and addressing modes. This byte is 0xCD for NAP configuration message identifying NanoBoot protocol data. Packets with unknown CT byte will be discarded.

4.3.4 cmd_id byte

The cmd_id byte is a byte which defines the packet type. Packet types relevant to the NanoBoot are listed in Table 3.

| cmd_id | Packet type |
|--------|---|
| 0x01 | FLASH_WRITE_PAGE |
| 0x81 | FLASH_WRITE_PAGE_CONFIRM |
| 0x02 | FLASH_WRITE_PAGE_DONE |
| 0x05 | MAC_ADDRESS_READ |
| 0x85 | MAC_ADDRESS_READ_CONFIRM / MAC_ADDRESS_SET_CONFIRM |
| 0x08 | MAC_ADDRESS_SET |
| 0x0A | APPLICATION_MODE_TOGGLE |
| 0x8A | APPLICATION_MODE_TOGGLE_REPLY |
| 0x09 | UNSUPPORTED_MESSAGE |
| 0x0B | VERSION_REQUEST |
| 0x8B | VERSION_REPLY |

Table 3. Command types

4.3.5 CS Byte

The checksum byte is calculated as Exclusive-OR (XOR) from all bytes of the packet (excluding the CS byte itself but including the length byte). The Sensinode NanoBoot protocol parser will discard packet if the checksum does not match.

4.4 API Commands

Table 4 describes the available commands and their respective payload structures. Bytes# describes variable fields of basic packet structure for each command.

| Command | CC1180 DIR. | Byte #1 | Byte #2 | Byte #3 | Byte #4 | Byte #5 | Byte #N |
|---|-------------|-------------|---------------|-------------|-------------|-------------|--------------|
| FLASH_WRITE_PAGE | IN | Page number | Encoding flag | Page setups | DATA byte 1 | DATA byte 2 | DATA byte 64 |
| FLASH_WRITE_PAGE_CONFIRM | OUT | Page number | - | - | - | - | - |
| FLASH_WRITE_PAGE_DONE | OUT | Page number | - | - | - | - | - |
| MAC_ADDRESS_READ | IN | - | - | - | - | - | - |
| MAC_ADDRESS_READ_CONFIRM MAC_ADDRESS_SET_CONFIRM | OUT | MAC byte 1 | MAC byte 2 | MAC byte 3 | MAC byte 4 | MAC byte 5 | MAC byte 8 |
| MAC_ADDRESS_SET | IN | MAC byte 1 | MAC byte 2 | MAC byte 3 | MAC byte 4 | MAC byte 5 | MAC byte 8 |
| APPLICATION_MODE_TOGGLE | IN | - | - | - | - | - | - |
| APPLICATION_MODE_TOGGLE_REPLY | OUT | - | - | - | - | - | - |
| VERSION_REQUEST | IN | - | - | - | - | - | - |

| Command | CC1180 DIR. | Byte #1 | Byte #2 | Byte #3 | Byte #4 | Byte #5 | Byte #N |
|---------------------|-------------|-----------------|-------------------------------|-------------------------------|-------------------------------|-------------------------------|-------------------------------|
| VERSION_REPLY | OUT | BL version byte | Application version byte 1 | Application version byte 2 | Application version byte 3 | Application version byte 4 | Application version byte 6 |
| UNSUPPORTED_MESSAGE | OUT | Error type | | | | | |

Table 4. Supported commands and their packet format

BL version byte – 0xf0 bits indicates integer part of version number, 0x0f bits indicates decimal part of version number, as integers. E.g. 0x10 shall be interpreted as version 1.0.

Application version byte – Version of the Sensinode NanoStack 2.0 Lite 6LoWPAN stack

Error type – 0x00 for NAP frame errors, any other value indicates a NanoBoot protocol error.

Encoding flag – is always 0x01.

4.5 State machine

This chapter describes the recommended method for implementing a state machine for a host application using NanoBoot protocol to communicate with a CC1180 network Processor. An example application that can be used to interact with the Sensinode NanoBoot bootloader to e.g. perform software update is described in CC-6LOWPAN-DK-868 User's Guide (SWRU298.pdf).

The figures below introduce the basic message flows that are supported in NanoBoot.

4.5.1 Example Message flows

Common for all figures below is that NanoBoot in **CC1180 must be** set in NanoBoot mode before any communication is initiated. NanoBoot mode can be entered by setting the MODE pin to ground once, or by sending *APPLICATION_MODE_TOGGLE* NAP protocol message from Host to Network Processor; assuming it has a valid application which supports mode toggle.

Figure 3 explains how MAC address is set to a **CC1180** Network Processor. Same communication flow also applies for message pairs *MAC_ADDRESS_READ/MAC_ADDRESS_READ_CONFIRM* and *VERSION_REQUEST/VERSION_REPLY*.

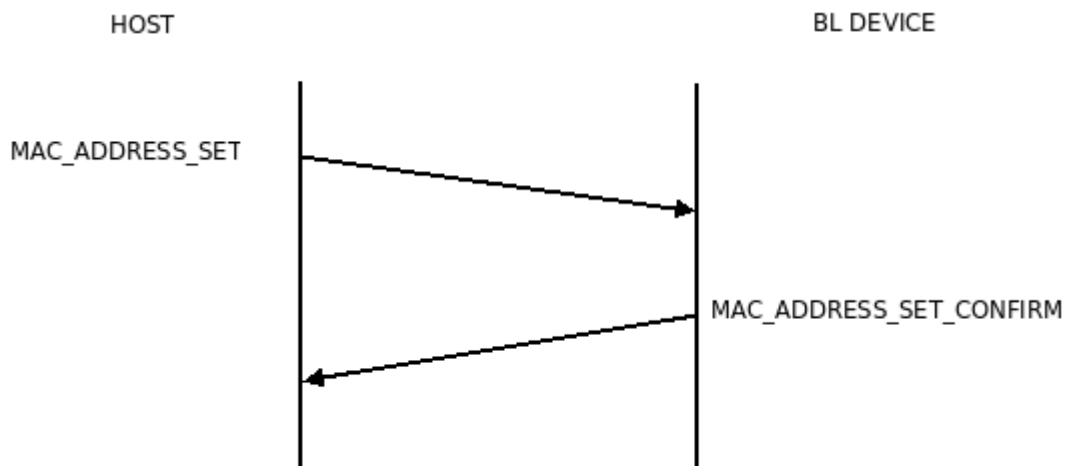

Figure 3. MAC address request

HOST represents PC or a host MCU device that implements the Host part of the communication protocol defined in this document. *BL Device* is the device running NanoBoot, i.e. **CC1180**.

Figure 4 describes a situation where *HOST* sends an unrecognized message to *BL Device*. If *BL Device* is in NanoBoot mode it responds with *UNSUPPORTED_MESSAGE* cmd_id. If *CS* byte match fails, 'N' / 'A' headers are missing or *CT* byte does not match, then no *UNSUPPORTED_MESSAGE* response is sent as received data is quietly discarded on *BL Device*.

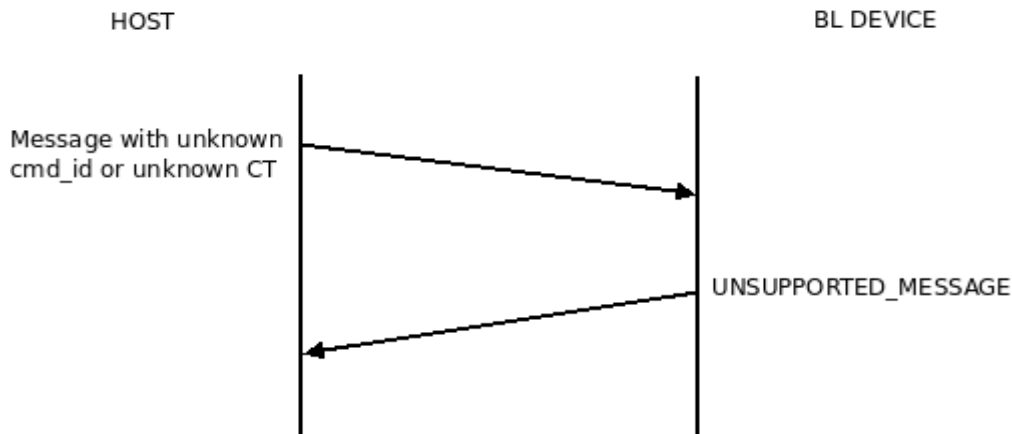

Figure 4. Unsupported data received by BL Device

To toggle between NanoBoot mode and application mode, message *APPLICATION_MODE_TOGGLE* can be used. This message type is one-way communication only as it switches *BL Device* mode immediately to application mode if NanoBoot is running when it is received. If the *HOST* sends the *APPLICATION_MODE_TOGGLE* message to *BL Device* while it is in application mode the *BL Device* will immediately toggle to NanoBoot mode.

4.6 Software update process

Software update can only be performed with a binary file provided by Sensinode Ltd. since Sensinode Ltd. encrypts the NanoStack 2.0 Lite 6LoWPAN stack. The *HOST* initializes communication by verifying that *BL Device* is in NanoBoot mode. This can be done by e.g. reading the MAC address of the **CC1180** device. If a valid reply is received, *BL Device* is in NanoBoot mode, since reading the MAC address is only possible if the device is in bootloader mode.

FLASH_WRITE_PAGE message consists of first page number, encoding flag, page setups and payload. Payload consists of 64 byte fragments of the complete binary file. The binary file has to be read so that first byte of *FLASH_WRITE_PAGE* payload is the 1024th byte of the binary file and the second byte of *FLASH_WRITE_PAGE* is the 1023rd byte of the binary file etc. Figure 5 demonstrates communication between *HOST* and *BL Device* during one flash page update.

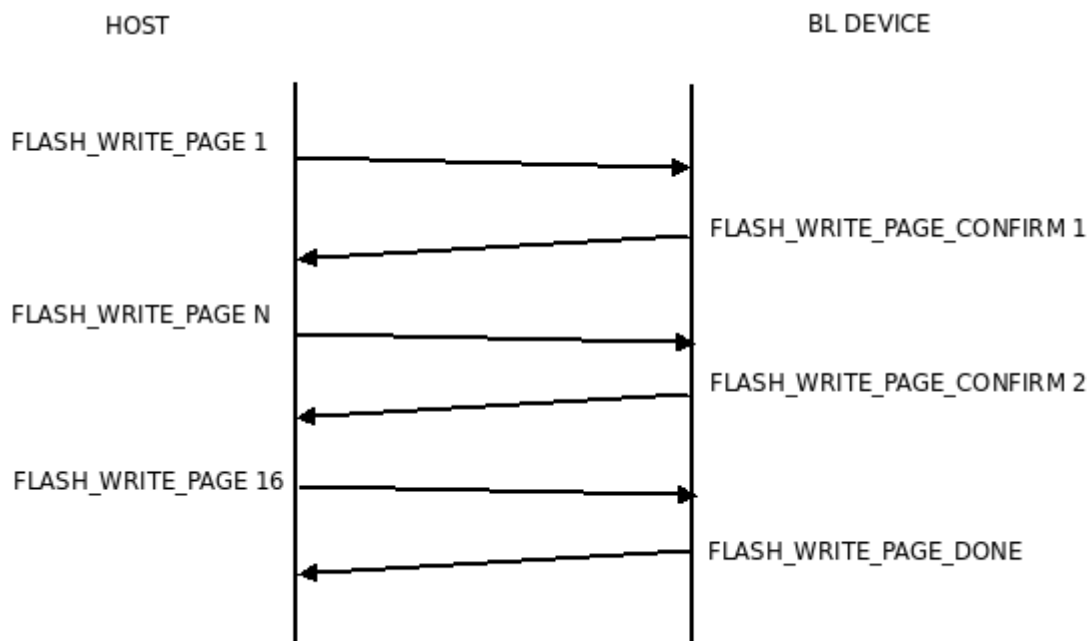

Figure 5. Software update process for one page

The single page flash update process is then repeated in order to send the complete binary file to *BL Device* in 64 byte blocks. If any errors occur during the process programming has to be restarted from beginning since binary is decrypted on *BL Device*. Possible error message is *UNSUPPORTED_MESSAGE*.

If programming is interrupted by the *BL Device* and it is not responding to *requests* it must be reset and NanoBoot mode initiated.

The NanoBoot cannot be overwritten as its bootloader flash memory area has write protection. Failure in the programming phase cannot cause errors to NanoBoot. The only way to remove the NanoBoot is to perform a complete chip erase via the debug interface. The debug interface is locked as well; the only allowed command is chip erase. *Note: Erasing the chip will result in having a blank CC110F32, with no possible way to recover the Sensinode NanoBoot.*

4.6.1 FLASH_WRITE_PAGE message details

When a fragment of the firmware is sent to *BL Device*, headers of *FLASH_WRITE_PAGE* message must contain page specific and slice specific information. *Page Number*, *Encoding* flag and *Page Setup* contains information to which address the binary data payload *should* go on device. Page Number is offset multiple(s) of 1024 bytes and Page Setup is an offset multiple(s) of 64 bytes.

One flash page in **CC1180** is 1024 bytes. Therefore minimum Page Number is 1 and maximum Page Number is 27, as application firmware (stack) must be placed in segment from 0x0400 to 0x6FFF. If the binary is transferred in 64 byte blocks, it makes 16 blocks of 64 byte each per page. Therefore minimum Page Setup is 0 and maximum is 15 for one flash page.

Page number byte states to which page payload is going to be flashed.

| Byte | Bit #7 | Bit #6 | Bit #5 | Bit #4 | Bit #3 | Bit #2 | Bit #1 | Bit #0 |
|-------------|--------|--------|--------|--------|--------|--------|--------|--------|
| Page Number | MSB | -- | -- | -- | -- | -- | -- | LSB |
| Page Setup | MSB | -- | -- | -- | -- | -- | -- | LSB |

Table 5. FLASH_WRITE_PAGE message configuration bytes

Encoding flag is **always** 0x01.

5 Debug Interface

The **CC1180** includes an on-chip debug interface, which communicates over a two-wire interface. The functionality of the debug interface in **CC1180** is limited to erasing the on-chip flash memory.

*Note: Erasing the chip will result in having a blank **CC1110F32**, with no possible way to recover the Sensinode NanoBoot. Do not connect the Debug Interface unless the intention is to remove the NanoBoot bootloader.*

The debug interface uses pins DEBUG_DATA and DEBUG_CLOCK. The only way to remove the NanoBoot bootloader is to perform a complete chip erase via the debug interface. For more information, see SWRS033.pdf.

6 Development Kit Ordering Information

| Orderable Evaluation Module | Description | Minimum Order Quantity |
|-----------------------------|--|------------------------|
| CC-6LOWPAN-DK-868 | Sub-GHz 6LoPWAN Development Kit, 868/915 MHz | 1 |

Table 6. Development Kit Ordering Information

7 References

- [1] CC1110 Datasheet (SWRS033.pdf)
- [2] CC-6LOWPAN-DK-868 User's Guide (SWRU298.pdf)

8 General Information

8.1 Document History

| Revision | Date | Description/Changes |
|----------|------------|---------------------|
| SWRS113 | 29.08.2011 | Initial Release |
| SWRS113A | 09.09.2011 | Editorial updates |

Table 7: Document History

PACKAGING INFORMATION

| Orderable Device | Status (1) | Package Type | Package Drawing | Pins | Package Qty | Eco Plan (2) | Lead/Ball Finish (6) | MSL Peak Temp (3) | Op Temp (°C) | Device Marking (4/5) | Samples |
|------------------|---------------|--------------|-----------------|------|-------------|-------------------------|-------------------------|----------------------|--------------|-------------------------|-------------------------|
| CC1180RSPR | ACTIVE | VQFN | RSP | 36 | 2500 | Green (RoHS & no Sb/Br) | CU NIPDAU | Level-3-260C-168 HR | -40 to 85 | CC1180 | Samples |
| CC1180RSPT | ACTIVE | VQFN | RSP | 36 | 250 | Green (RoHS & no Sb/Br) | CU NIPDAU | Level-3-260C-168 HR | -40 to 85 | CC1180 | Samples |

(1) The marketing status values are defined as follows:

ACTIVE: Product device recommended for new designs.

LIFEBUY: TI has announced that the device will be discontinued, and a lifetime-buy period is in effect.

NRND: Not recommended for new designs. Device is in production to support existing customers, but TI does not recommend using this part in a new design.

PREVIEW: Device has been announced but is not in production. Samples may or may not be available.

OBsolete: TI has discontinued the production of the device.

(2) Eco Plan - The planned eco-friendly classification: Pb-Free (RoHS), Pb-Free (RoHS Exempt), or Green (RoHS & no Sb/Br) - please check <http://www.ti.com/productcontent> for the latest availability information and additional product content details.

TBD: The Pb-Free/Green conversion plan has not been defined.

Pb-Free (RoHS): TI's terms "Lead-Free" or "Pb-Free" mean semiconductor products that are compatible with the current RoHS requirements for all 6 substances, including the requirement that lead not exceed 0.1% by weight in homogeneous materials. Where designed to be soldered at high temperatures, TI Pb-Free products are suitable for use in specified lead-free processes.

Pb-Free (RoHS Exempt): This component has a RoHS exemption for either 1) lead-based flip-chip solder bumps used between the die and package, or 2) lead-based die adhesive used between the die and leadframe. The component is otherwise considered Pb-Free (RoHS compatible) as defined above.

Green (RoHS & no Sb/Br): TI defines "Green" to mean Pb-Free (RoHS compatible), and free of Bromine (Br) and Antimony (Sb) based flame retardants (Br or Sb do not exceed 0.1% by weight in homogeneous material)

(3) MSL, Peak Temp. - The Moisture Sensitivity Level rating according to the JEDEC industry standard classifications, and peak solder temperature.

(4) There may be additional marking, which relates to the logo, the lot trace code information, or the environmental category on the device.

(5) Multiple Device Markings will be inside parentheses. Only one Device Marking contained in parentheses and separated by a "~" will appear on a device. If a line is indented then it is a continuation of the previous line and the two combined represent the entire Device Marking for that device.

(6) Lead/Ball Finish - Orderable Devices may have multiple material finish options. Finish options are separated by a vertical ruled line. Lead/Ball Finish values may wrap to two lines if the finish value exceeds the maximum column width.

Important Information and Disclaimer: The information provided on this page represents TI's knowledge and belief as of the date that it is provided. TI bases its knowledge and belief on information provided by third parties, and makes no representation or warranty as to the accuracy of such information. Efforts are underway to better integrate information from third parties. TI has taken and continues to take reasonable steps to provide representative and accurate information but may not have conducted destructive testing or chemical analysis on incoming materials and chemicals. TI and TI suppliers consider certain information to be proprietary, and thus CAS numbers and other limited information may not be available for release.

In no event shall TI's liability arising out of such information exceed the total purchase price of the TI part(s) at issue in this document sold by TI to Customer on an annual basis.

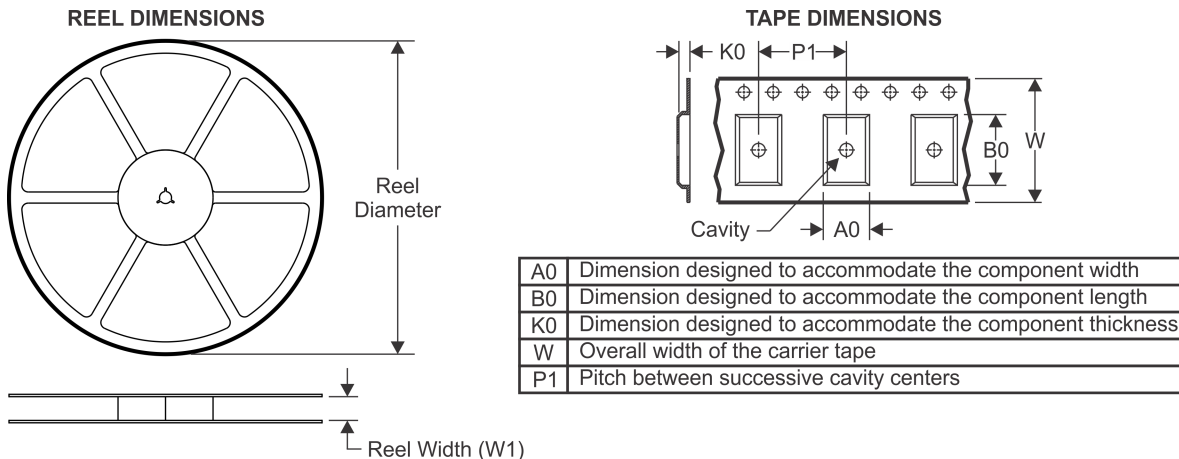
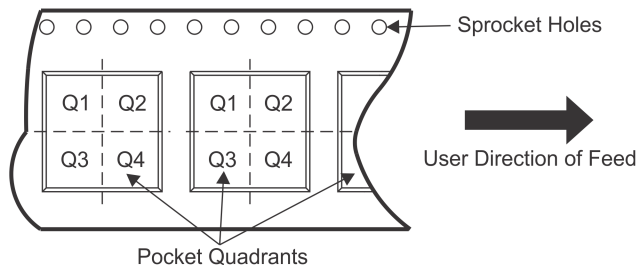
TAPE AND REEL INFORMATION

QUADRANT ASSIGNMENTS FOR PIN 1 ORIENTATION IN TAPE

*All dimensions are nominal

| Device | Package Type | Package Drawing | Pins | SPQ | Reel Diameter (mm) | Reel Width W1 (mm) | A0 (mm) | B0 (mm) | K0 (mm) | P1 (mm) | W (mm) | Pin1 Quadrant |
|------------|--------------|-----------------|------|------|--------------------|--------------------|---------|---------|---------|---------|--------|---------------|
| CC1180RSPR | VQFN | RSP | 36 | 2500 | 330.0 | 16.4 | 6.3 | 6.3 | 1.5 | 12.0 | 16.0 | Q2 |
| CC1180RSPT | VQFN | RSP | 36 | 250 | 180.0 | 16.4 | 6.3 | 6.3 | 1.5 | 12.0 | 16.0 | Q2 |

TAPE AND REEL BOX DIMENSIONS

*All dimensions are nominal

| Device | Package Type | Package Drawing | Pins | SPQ | Length (mm) | Width (mm) | Height (mm) |
|------------|--------------|-----------------|------|------|-------------|------------|-------------|
| CC1180RSPR | VQFN | RSP | 36 | 2500 | 336.6 | 336.6 | 28.6 |
| CC1180RSPT | VQFN | RSP | 36 | 250 | 213.0 | 191.0 | 55.0 |

RSP (S-PQFP-N36)

PLASTIC QUAD FLATPACK

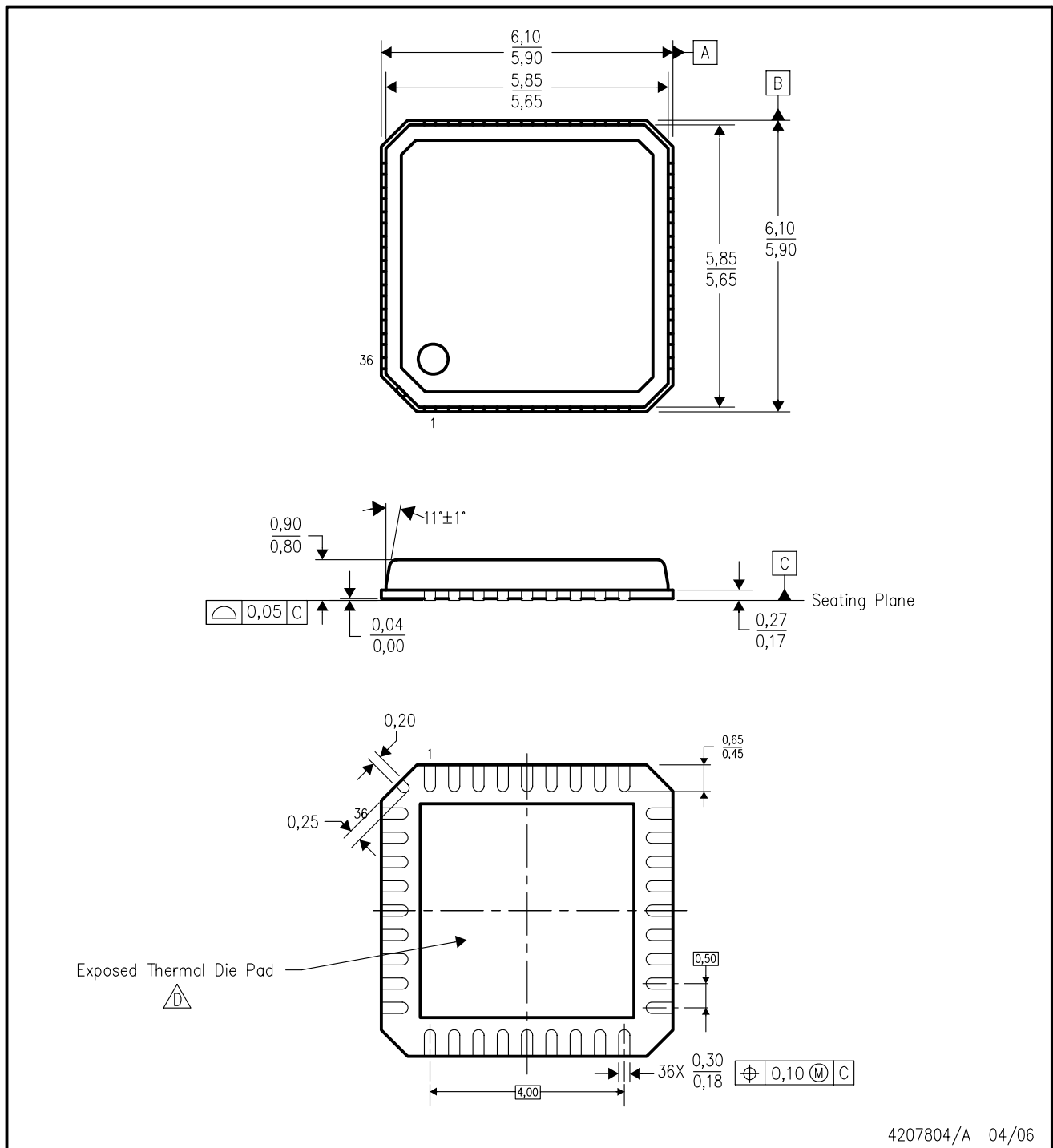

4207804/A 04/06

- NOTES:
- A. All linear dimensions are in millimeters.
 - B. This drawing is subject to change without notice.
 - C. QFN (Quad Flatpack No-Lead) Package configuration.
 -  The package thermal pad must be soldered to the board for thermal and mechanical performance. See the Product Data Sheet for details regarding the exposed thermal pad dimensions.

THERMAL INFORMATION

This package incorporates an exposed thermal pad that is designed to be attached directly to an external heatsink. The thermal pad must be soldered directly to the printed circuit board (PCB). After soldering, the PCB can be used as a heatsink. In addition, through the use of thermal vias, the thermal pad can be attached directly to the appropriate copper plane shown in the electrical schematic for the device, or alternatively, can be attached to a special heatsink structure designed into the PCB. This design optimizes the heat transfer from the integrated circuit (IC).

For information on the Quad Flatpack No-Lead (QFN) package and its advantages, refer to Application Report, QFN/SON PCB Attachment, Texas Instruments Literature No. SLUA271. This document is available at www.ti.com.

The exposed thermal pad dimensions for this package are shown in the following illustration.

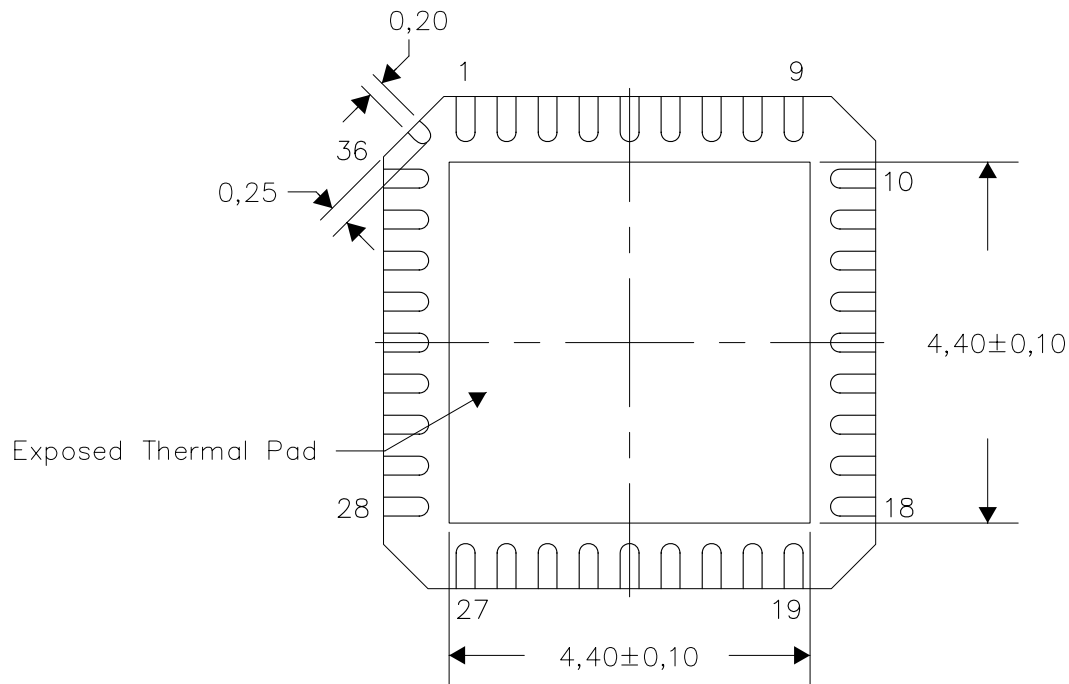

Bottom View

NOTE: All linear dimensions are in millimeters

Exposed Thermal Pad Dimensions

IMPORTANT NOTICE

Texas Instruments Incorporated and its subsidiaries (TI) reserve the right to make corrections, enhancements, improvements and other changes to its semiconductor products and services per JESD46, latest issue, and to discontinue any product or service per JESD48, latest issue. Buyers should obtain the latest relevant information before placing orders and should verify that such information is current and complete. All semiconductor products (also referred to herein as "components") are sold subject to TI's terms and conditions of sale supplied at the time of order acknowledgment.

TI warrants performance of its components to the specifications applicable at the time of sale, in accordance with the warranty in TI's terms and conditions of sale of semiconductor products. Testing and other quality control techniques are used to the extent TI deems necessary to support this warranty. Except where mandated by applicable law, testing of all parameters of each component is not necessarily performed.

TI assumes no liability for applications assistance or the design of Buyers' products. Buyers are responsible for their products and applications using TI components. To minimize the risks associated with Buyers' products and applications, Buyers should provide adequate design and operating safeguards.

TI does not warrant or represent that any license, either express or implied, is granted under any patent right, copyright, mask work right, or other intellectual property right relating to any combination, machine, or process in which TI components or services are used. Information published by TI regarding third-party products or services does not constitute a license to use such products or services or a warranty or endorsement thereof. Use of such information may require a license from a third party under the patents or other intellectual property of the third party, or a license from TI under the patents or other intellectual property of TI.

Reproduction of significant portions of TI information in TI data books or data sheets is permissible only if reproduction is without alteration and is accompanied by all associated warranties, conditions, limitations, and notices. TI is not responsible or liable for such altered documentation. Information of third parties may be subject to additional restrictions.

Resale of TI components or services with statements different from or beyond the parameters stated by TI for that component or service voids all express and any implied warranties for the associated TI component or service and is an unfair and deceptive business practice. TI is not responsible or liable for any such statements.

Buyer acknowledges and agrees that it is solely responsible for compliance with all legal, regulatory and safety-related requirements concerning its products, and any use of TI components in its applications, notwithstanding any applications-related information or support that may be provided by TI. Buyer represents and agrees that it has all the necessary expertise to create and implement safeguards which anticipate dangerous consequences of failures, monitor failures and their consequences, lessen the likelihood of failures that might cause harm and take appropriate remedial actions. Buyer will fully indemnify TI and its representatives against any damages arising out of the use of any TI components in safety-critical applications.

In some cases, TI components may be promoted specifically to facilitate safety-related applications. With such components, TI's goal is to help enable customers to design and create their own end-product solutions that meet applicable functional safety standards and requirements. Nonetheless, such components are subject to these terms.

No TI components are authorized for use in FDA Class III (or similar life-critical medical equipment) unless authorized officers of the parties have executed a special agreement specifically governing such use.

Only those TI components which TI has specifically designated as military grade or "enhanced plastic" are designed and intended for use in military/aerospace applications or environments. Buyer acknowledges and agrees that any military or aerospace use of TI components which have **not** been so designated is solely at the Buyer's risk, and that Buyer is solely responsible for compliance with all legal and regulatory requirements in connection with such use.

TI has specifically designated certain components as meeting ISO/TS16949 requirements, mainly for automotive use. In any case of use of non-designated products, TI will not be responsible for any failure to meet ISO/TS16949.

Products

| | |
|------------------------------|--|
| Audio | www.ti.com/audio |
| Amplifiers | amplifier.ti.com |
| Data Converters | dataconverter.ti.com |
| DLP® Products | www.dlp.com |
| DSP | dsp.ti.com |
| Clocks and Timers | www.ti.com/clocks |
| Interface | interface.ti.com |
| Logic | logic.ti.com |
| Power Mgmt | power.ti.com |
| Microcontrollers | microcontroller.ti.com |
| RFID | www.ti-rfid.com |
| OMAP Applications Processors | www.ti.com/omap |
| Wireless Connectivity | www.ti.com/wirelessconnectivity |

Applications

| | |
|-------------------------------|--|
| Automotive and Transportation | www.ti.com/automotive |
| Communications and Telecom | www.ti.com/communications |
| Computers and Peripherals | www.ti.com/computers |
| Consumer Electronics | www.ti.com/consumer-apps |
| Energy and Lighting | www.ti.com/energy |
| Industrial | www.ti.com/industrial |
| Medical | www.ti.com/medical |
| Security | www.ti.com/security |
| Space, Avionics and Defense | www.ti.com/space-avionics-defense |
| Video and Imaging | www.ti.com/video |

TI E2E Community

e2e.ti.com

Looking for pricing, stock, or lifecycle information?

Click below to explore more details on WIN SOURCE:

-  [View CC1180RSPR on WIN SOURCE](#)
-  [Texas Instruments](#) Information

Optimize Your Supply Chain with WIN SOURCE Solutions

-  Global Sourcing Solution
-  Obsolete Management
-  Cost Control Management
-  Shortage Management
-  Alternative Solution
-  Excess Inventory Management