

# AIROC™ CYW55513/2/1 Wi-Fi & Bluetooth® combo

Low-power, 1 x 1, 2.4/5/6 GHz, IEEE 802.11ax, 20 MHz, Wi-Fi 6/6E, Bluetooth® 5.4

Infineon delivers market-proven AIROC™ Wi-Fi and Bluetooth® system on chip combos with robust, reliable, and secure wireless connectivity. Infineon is an industry leader in Wi-Fi for the IoT with over 1 billion wireless devices in the field, over the last 20 years, making AIROC™ the most deployed wireless IP in the industry.

The AIROC™ CYW55513/2/1 are a family of low-power, single-chip devices that support 1x1 single-stream, tri-band (CYW55513), dual-band (CYW55512) and single-band (CYW55511), Wi-Fi 6/6E, IEEE 802.11ax-compliant Wi-Fi MAC/baseband/radio, and Bluetooth®/Bluetooth® Low Energy 5.4. The device supports up to 1024 QAM MCS11 in 20 MHz channels delivering PHY rates up to 143 Mbps. CYW55513/2/1 provide best-in-class range/coverage by delivering up to 24 dBm of transmit power, and sensitivity down to -101.5 dBm, while supporting Wi-Fi 6/6E range improving features such as HR ER-PPDU, longer guard intervals, long OFDM symbol, and dual-carrier modulation (DCM), with Infineon range improvements for legacy rate devices. SDIO and gSPI interfaces available for interfacing to an array of A-Class (Linux/Android) and M-Class (RTOS) host processors.

CYW55513/2/1 include a Bluetooth® 5.4-compliant subsystem, with a 192 MHz Arm® Cortex®-CM33 processor, supporting Bluetooth® classic (BDR, EDR for A2DP/HFP) and Bluetooth® Low Energy audio (LC3 codec), running in hosted/controller or embedded mode where it can offload the host processor.

Additionally, the devices support Bluetooth® LE 2 Mbps, Bluetooth® LE 1 Mbps, Low-Energy long-range (LR), and periodic advertising extensions. The devices integrate three power amplifiers delivering +4/+13/+19 dBm offering best-efficiency for each power level. The long range performance is delivered with industry leading -111.5 dBm LE long range (125 kbps S = 8) sensitivity, paired with the high-power integrated PA, deliver best-in-class LE long-range performance. The UART, SDIO shared with Wi-Fi, TDM/I²S, PDM, and analog microphone, plus additional GPIOs are available.

The reliable, high-performance AIROC™ CYW55513/2/1 Wi-Fi and Bluetooth® 5.4 combos deliver powerful Wi-Fi capabilities that go beyond the Wi-Fi 6/6E standard for congested networks in IoT, smart home, and wearable applications and get you to market faster by speeding up the development time through a broad array of module vendors.

For more information go to: [CYW55513](#), [CYW55512](#), [CYW55511](#)



## Key features

### Wi-Fi/WLAN features

- Leading transmit power: +24 dBm
- Best in class sensitivity: -101.5 dBm
- Wi-Fi 6/6E: range improving features: HE ER-PPDU, long guard Intervals, long OFDM symbol, DCM
- Wi-Fi 6E greenfield spectrum for lower latency and improved range
- Leading transmit power: +24 dBm
- 11ax target wake time (TWT)
- WPA2/WPA3 Personal/Enterprise
- Supports internal or external LNA/PA and antenna diversity

### Bluetooth® features

- Bluetooth® 5.4 (Classic + LE)
- Embedded or hosted AIROC™ Stack
- Embedded LE isochronous channel w/LC3 CODEC for Bluetooth® LE audio
- LE 2M, LE 1M, LE LR, ADV extensions
- Three output power paths optimized for best efficiency: +4/ +13/ +19 dBm
- Support shared or dedicated antenna for optimized coexistence with Wi-Fi, 802.15.4/Thread, LTE

### Interfaces

- WLAN: SDIO 3.0, shared SDIO, and GSPi
- Bluetooth®: HSUART, and shared SDIO
- Audio: 2x TDM (I²S/PCM), DMI

### Coexistence

- Advanced coexistence 2-wire BTSIG WCI-2 (LTE) and 3-wire (ZigBee)

### Package

- WLBGA

## Key benefits

- Best range Wi-Fi 6/6E
- Power efficient Wi-Fi /Bluetooth®
- Bluetooth® 5.4/LE audio



**PRODUCT BRIEF**

**Key applications**

Smart home/IoT	Smart home, IP cameras, door locks, appliances, printers, speakers, gaming, cameras
Wearables	Smart watches, fitness bands
Industrial/Medical	Conference systems, automated meter readers, payment systems

**Infinion and module partner product summary**

Product	Description	Operating temp	Package/dimensions
CYW55513IUBGT	1x1 802.11ax 2.4/5/6 GHz 20 MHz and Bluetooth® 5.4 combo	-40°C to 85°C	WLPGA
CYW55512IUBGT	1x1 802.11ax 2.4/5 GHz 20 MHz and Bluetooth® 5.4 combo	-40°C to 85°C	WLPGA
CYW55511IUBGT	1x1 802.11ax 2.4 GHz 20 MHz and Bluetooth® 5.4 combo	-40°C to 85°C	WLPGA
<u>U-Blox MAYA-W3</u>	U-Blox CYW55513/2/1 Modules, U.FL connectors or antennas	-40°C to 85°C	10 x 14 mm SMD
<u>Ezurio Sona IF513</u>	Ezurio CYW55513 Module, RF Trace or MHF4L connectors	-40°C to 85°C	12 x 16 mm M.2 1216 SMT
<u>AW-XM606</u>	Azurewave CYW55513 Module with RF trace	-40°C to 85°C	12x12 mm LGA
<u>Murata 2FY</u>	Murata CYW55513 Module	-40°C to 85°C	7.9 x 7.3 mm
<u>WM-BAX-CYW65</u>	USI CYW55513 SIP Module with RF trace	-40°C to 85°C	8.6x8.1 mm Molding SIP

**CYW55513 wireless connectivity family**

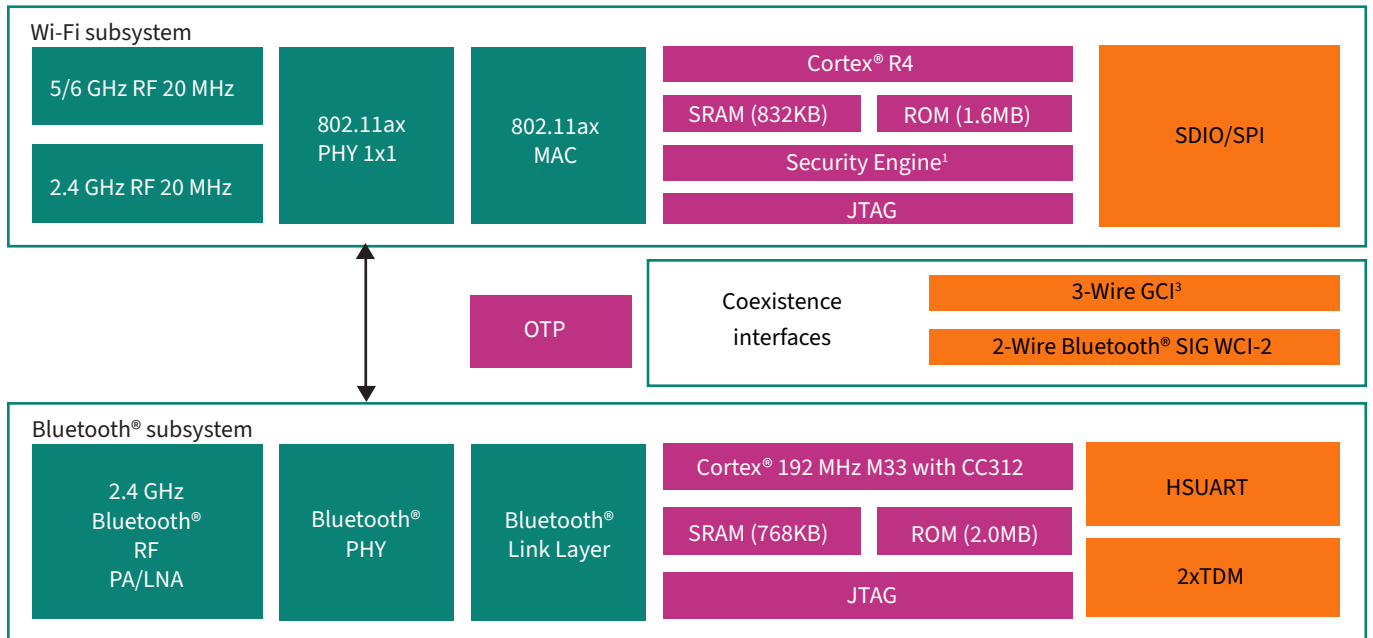

For more module options visit [here](#).

Support in the [Infineon Developer Community](#) with online direct access to application support engineers.

Published by  
Infineon Technologies AG  
Am Campeon 1-15, 85579 Neubiberg  
Germany

© 2024 Infineon Technologies AG  
All rights reserved.

Public

Document number: 002-40109 REV. \*A  
Date: 06/2024

**Please note!**

This Document is for information purposes only and any information given herein shall in no event be regarded as a warranty, guarantee or description of any functionality, conditions and/or quality of our products or any suitability for a particular purpose. With regard to the technical specifications of our products, we kindly ask you to refer to the relevant product data sheets provided by us. Our customers and their technical departments are required to evaluate the suitability of our products for the intended application.

We reserve the right to change this document and/or the information given herein at any time.

**Additional information**

For further information on technologies, our products, the application of our products, delivery terms and conditions and/or prices, please contact your nearest Infineon Technologies office ([www.infineon.com](http://www.infineon.com)).

**Warnings**

Due to technical requirements, our products may contain dangerous substances. For information on the types in question, please contact your nearest Infineon Technologies office.

Except as otherwise explicitly approved by us in a written document signed by authorized representatives of Infineon Technologies, our products may not be used in any life-endangering applications, including but not limited to medical, nuclear, military, life-critical or any other applications where a failure of the product or any consequences of the use thereof can result in personal injury.



Scan QR code and explore offering  
[www.infineon.com](http://www.infineon.com)

## Looking for pricing, stock, or lifecycle information?

Click below to explore more details on WIN SOURCE:

 [View CYW55513IUBGT on WIN SOURCE](#)

 [Infineon Technologies](#) Information

## Optimize Your Supply Chain with WIN SOURCE Solutions

-  Global Sourcing Solution
-  Obsolete Management
-  Cost Control Management
-  Shortage Management
-  Alternative Solution
-  Excess Inventory Management