

Low-Resistance Current Sensor in QFN Package

FEATURES AND BENEFITS

- Ultra-low primary conductor resistance, $<100\ \mu\Omega$, for high efficiency and high-inrush current capability
- Differential Hall sensing rejects common-mode fields
- Small footprint, $4\ \text{mm} \times 4\ \text{mm}$ QFN package with wettable flank, suitable for space-constrained automotive applications
- High-bandwidth 150 kHz analog output for fast response time in control applications
- Patented integrated digital temperature compensation circuitry
- Overcurrent fault output with configurable threshold
- Non-ratiometric output
- 3.3 V and 5 V supply options
- $100\ \text{V}_{\text{RMS}}$ functional isolation

DESCRIPTION

The ACS37220 is an integrated current sensor that senses current flowing through the primary conductor of a compact 7-pin QFN package.

The small $4\ \text{mm} \times 4\ \text{mm}$ sensor has very low internal conductor resistance, $<100\ \mu\Omega$, and is designed to measure currents up to 200 A. The current is sensed differentially via two Hall plates that provide common-mode field rejection and optimized performance in the presence of external magnetic fields.

The ACS37220 is factory-calibrated for high accuracy over the entire operating temperature range. It is an automotive grade 0 device capable of operating between -40°C and 150°C ambient temperatures. 5 V and 3.3 V supply voltage variants are available with current sensing ranges from 100 A to 200 A. An overcurrent fault output, with user-configurable threshold, provides fast short-circuit detection for enhanced system protection.

The ACS37220 is a lead (Pb) free device plated with 100% matte tin, compatible with standard lead-free printed circuit board assembly processes.

PACKAGE: 7-pin QFN with Wettable Flank (suffix EZ)

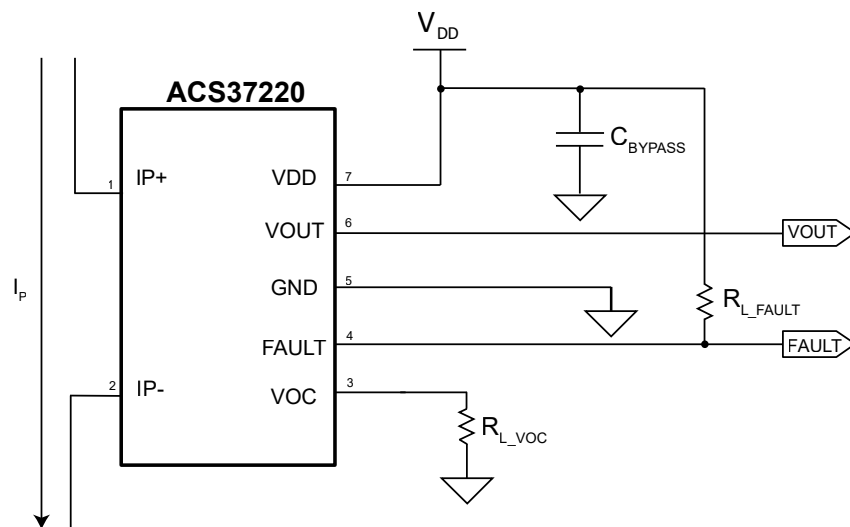
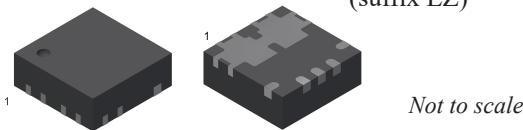
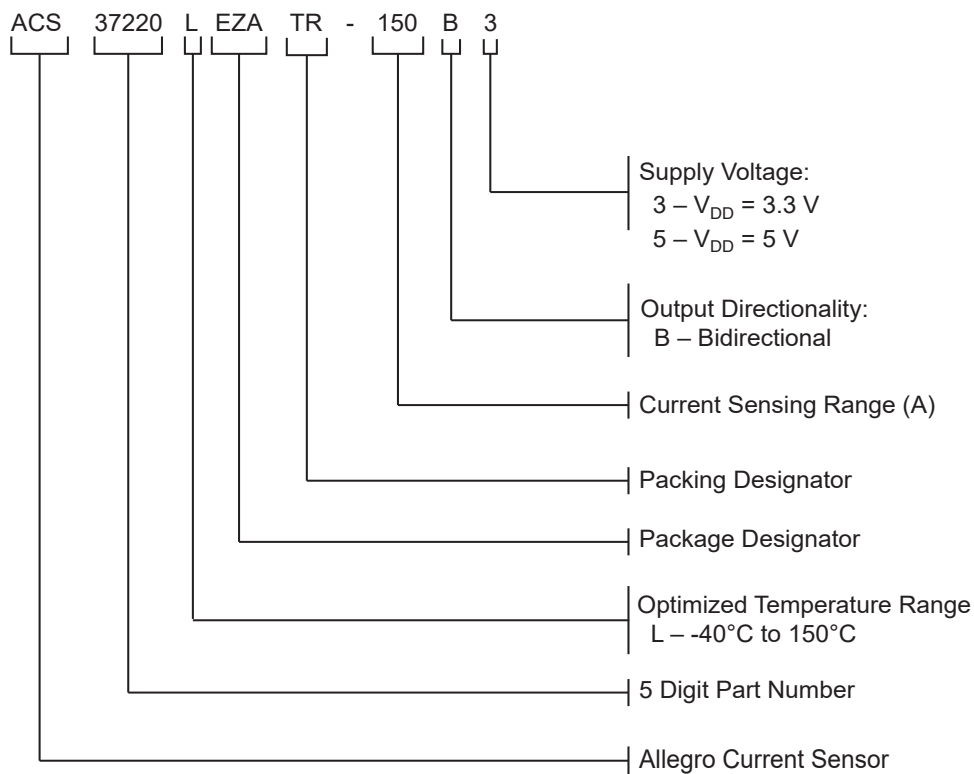

Figure 1: Typical Application Circuit

The ACS37220 outputs an analog signal at VOUT that varies linearly with the primary current, I_p , within the specified ranges.

SELECTION GUIDE

Part Number	Current Sensing Range (A)	Sensitivity (mV/A)	Supply Voltage V_{DD} (V)	Quiescent Voltage Output V_{QVO} (V)	Optimized Temperature Range T_A (°C)	Packing
ACS37220LEZATR-100B3	±100	13.2	3.3	1.65	-40 to 150	Tape and Reel, 3000 pieces per reel
ACS37220LEZATR-150B3	±150	8.8				
ACS37220LEZATR-100B5	±100	20	5	2.5		
ACS37220LEZATR-150B5	±150	13.3				
ACS37220LEZATR-200B5	±200	10				



ABSOLUTE MAXIMUM RATINGS [1]

Characteristic	Symbol	Notes	Min.	Max.	Unit
Supply Voltage	V_{DD}		-0.5	6.5	V
Forward Output Voltage	V_O	Applies to VOUT, VOC, and FAULT	-0.5	$(V_{DD} + 0.7) < 6.5$	V
Operating Ambient Temperature	T_A		-40	150	°C
Storage Temperature	T_{stg}		-65	165	°C
Maximum Junction Temperature	$T_{J(MAX)}$		-	165	°C

[1] Stresses above those listed under Absolute Maximum Ratings may cause permanent damage to the device. This is a stress rating only; functional operation of the device at these or any other conditions above those indicated in the operational sections of this specification is not implied. Exposure to absolute maximum ratings for extended periods may affect device reliability.

ISOLATION CHARACTERISTICS

Characteristic	Symbol	Notes	Value	Units
Working Voltage for Functional Isolation	V_{WVBI}	Approved working voltage for functional isolation	100	V_{RMS}
Creepage	D_{CR}	Distance along package body between the IP pins and signal pins	1	mm

PACKAGE CHARACTERISTICS

Characteristic	Symbol	Notes	Min.	Typ.	Max.	Unit
Internal Conductor Resistance	R_{IC}	$T_A = 25^\circ\text{C}$	-	100	-	$\mu\Omega$
Internal Conductor Inductance	L_{IC}	$T_A = 25^\circ\text{C}$	-	0.5	-	nH
Moisture Sensitivity Level	MSL	Per IPC/JEDEC J-STD-020	-	2	-	-

THERMAL CHARACTERISTICS

Characteristic	Symbol	Notes	Value	Unit
Package Thermal Resistance (Junction to Ambient)	$R_{\theta JA}$	Mounted on the Allegro EZ Current Sensor Evaluation Board (ACSEVB-EZ7)	55	°C/W
Package Thermal Metric (Junction to Top)	Ψ_{JT}		7.5	°C/W

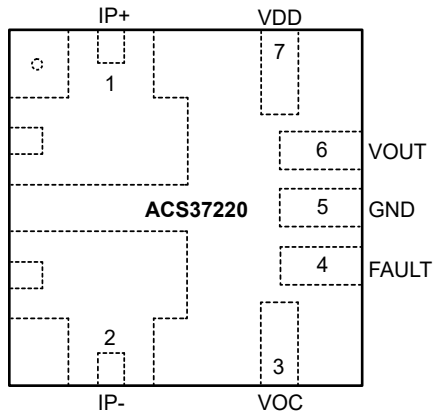

Terminal List Table

Number	Name	Description
1	IP+	Positive terminal for current being sensed
2	IP-	Negative terminal for current being sensed
3	VOC	User-configurable overcurrent fault threshold
4	FAULT	Overcurrent fault output, active low
5	GND	Device ground terminal
6	VOUT	Analog output signal
7	VDD	Device power supply terminal

Figure 2: EZ package pinout diagram (top view)

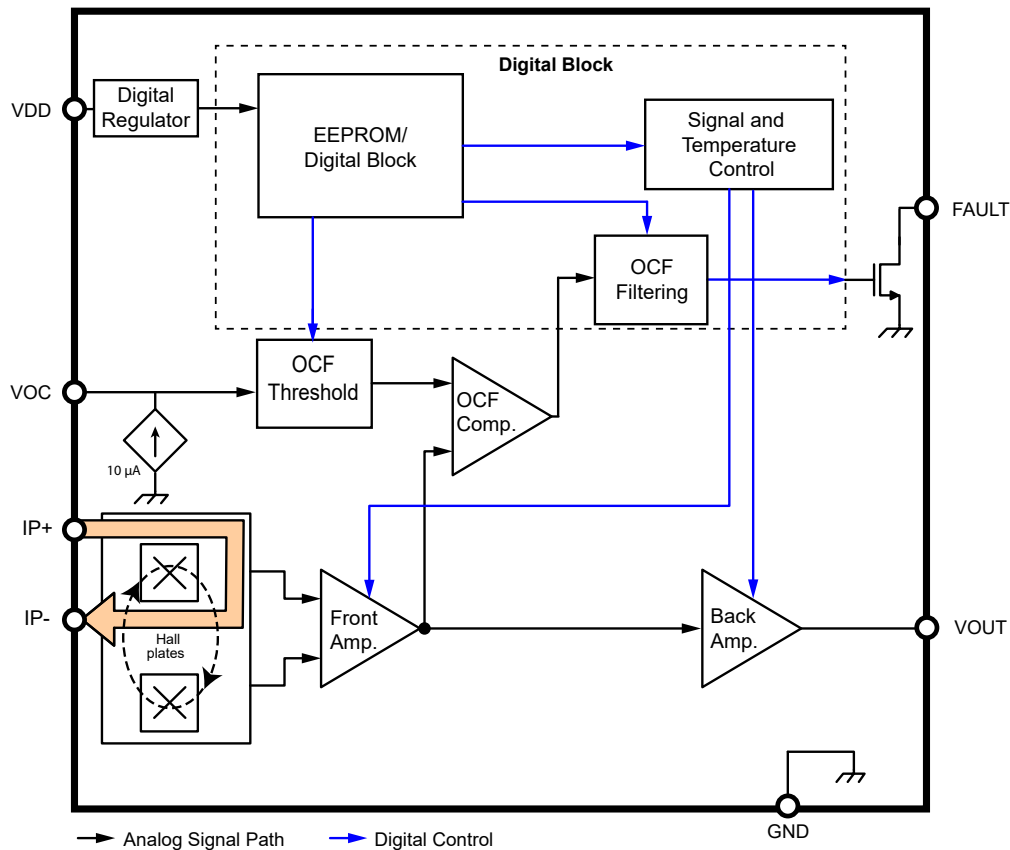

Figure 3: Functional block diagram

COMMON ELECTRICAL CHARACTERISTICS: Valid through the full operating temperature range, $T_A = -40^\circ\text{C}$ to 150°C , $C_{\text{BYPASS}} = 0.1\mu\text{F}$, and $V_{\text{DD}} = V_{\text{DD(TYP)}}$, unless specified otherwise. Minimum and maximum values are tested in production or validated by design and characterization.

Characteristic	Symbol	Test Conditions	Min.	Typ.	Max.	Units
Supply Voltage	V_{DD}	5 V variant	4.5	5	5.5	V
		3.3 V variant	3.15	3.3	3.45	V
Supply Current	I_{DD}	VOUT, FAULT, and VOC open; $T_A = -40^\circ\text{C}$	–	–	15.5	mA
Supply Bypass Capacitor	C_{BYPASS}		–	0.1	–	μF
Output Resistive Load [1]	$R_{\text{L_VOUT}}$		10	–	–	k Ω
Output Capacitive Load [1]	$C_{\text{L_VOUT}}$		–	–	4.7	nF
Power-On Reset Voltage	V_{POR}	$T_A = 25^\circ\text{C}$, V_{DD} rising 1 V/ms	2.65	–	3	V
Power-On Reset Hysteresis	$V_{\text{POR_HYS}}$	$T_A = 25^\circ\text{C}$	250	–	350	mV
Power-On Time	t_{PO}		–	80	–	μs
OUTPUT SIGNAL CHARACTERISTICS (VOUT)						
Saturation Voltage [2]	$V_{\text{SAT_H}}$	$T_A = 25^\circ\text{C}$, $V_{\text{DD}} = V_{\text{DD(Typ.)}}$	$V_{\text{DD}} - 0.3$	–	–	V
	$V_{\text{SAT_L}}$	$T_A = 25^\circ\text{C}$, $V_{\text{DD}} = V_{\text{DD(Typ.)}}$	–	–	0.3	V
Short Circuit Current	$I_{\text{SC_VOUT}}$	VOUT to GND	–	30	–	mA
Bandwidth	BW	Small signal –3 dB, $C_{\text{L}} = 100\text{ pF}$	–	150	–	kHz
Rise Time	t_{R}	$C_{\text{L}} = 100\text{ pF}$	–	2.3	–	μs
Response Time [1]	t_{RESP}	$C_{\text{L}} = 100\text{ pF}$	–	–	4	μs
Propagation Delay	t_{PD}	$C_{\text{L}} = 100\text{ pF}$	–	1.6	–	μs
Noise Density	N_{D}	5 V variant, $C_{\text{L}} = 1\text{ nF}$	–	550	–	$\mu\text{A}/\sqrt{\text{Hz}}$
		3.3 V variant, $C_{\text{L}} = 1\text{ nF}$	–	660	–	$\mu\text{A}/\sqrt{\text{Hz}}$
Common-Mode Field Rejection	CMFR	Input-referred error due to common-mode field	–	2	–	mA/G
OVERCURRENT FAULT OUTPUT CHARACTERISTICS (FAULT)						
Overcurrent FAULT Threshold Range	I_{OCR}	$T_A = 25^\circ\text{C}$	50	–	200	% $I_{\text{PR(Max)}}$
VOC Input Linear Operating Range	$V_{\text{OR_VOC}}$	5 V variant, $T_A = 25^\circ\text{C}$	0.5	1	2	V
		3.3 V variant, $T_A = 25^\circ\text{C}$	0.33	0.66	1.32	V
VOC Input Low Voltage	$V_{\text{VOC_L}}$		–	0.1	–	V
VOC Leakage Current	$I_{\text{VOC_OFF}}$		–	10	–	μA
Overcurrent FAULT Pull-Up Resistor	$R_{\text{L_FAULT}}$		–	10	–	k Ω
Overcurrent FAULT Output Error	E_{OC}	$T_A = 25^\circ\text{C}$	–12	–	12	% $I_{\text{PR(MAX)}}$
Overcurrent FAULT Output Low Voltage	$V_{\text{FAULT_L}}$	$R_{\text{L_FAULT}} = 10\text{ k}\Omega$, fault condition present	–	–	0.3	V
Overcurrent FAULT Leakage Current	$I_{\text{FAULT_OFF}}$	$R_{\text{L_FAULT}} = 10\text{ k}\Omega$, no fault condition present	–	100	–	nA
Overcurrent FAULT Hysteresis	$I_{\text{OC_HYS}}$	$T_A = 25^\circ\text{C}$	3.5	–	–	% $I_{\text{PR(MAX)}}$
Overcurrent FAULT Response Time	$t_{\text{OC_RESP}}$		–	3	–	μs

[1] Validated by design and characterization.

[2] The sensor may continue to respond to current beyond the specified Current Sensing Range, I_{PR} , until the output saturates at the high or low saturation voltage; however, the linearity and performance beyond the specified Current Sensing Range are not validated.

ACS37220LEZA-100B3 PERFORMANCE CHARACTERISTICS: Valid through the full operating temperature range, $T_A = -40^\circ\text{C}$ to 150°C , $C_{\text{BYPASS}} = 0.1 \mu\text{F}$, and $V_{\text{DD}} = 3.3 \text{ V}$, unless specified otherwise. Minimum and maximum values are tested in production.

Characteristic	Symbol	Test Conditions	Min.	Typ.	Max.	Units
NOMINAL PERFORMANCE						
Current Sensing Range [1]	I_{PR}	Limited by $T_{\text{J(MAX)}} = 165^\circ\text{C}$	-100	-	100	A
Sensitivity	Sens	$I_{\text{PR(MIN)}} < I_{\text{P}} < I_{\text{PR(MAX)}}$	-	13.2	-	mV/A
Quiescent Voltage Output	V_{QVO}	$I_{\text{P}} = 0 \text{ A}$	-	1.65	-	V
Overcurrent FAULT Threshold	I_{OC}	$V_{\text{VOC}} = 0.661 \text{ V}$ or $V_{\text{VOC}} < V_{\text{VOC_L}}$	-	100	-	% I_{PR}
OVERCURRENT FAULT OUTPUT						
Overcurrent FAULT Error	$I_{\text{OC_E}}$	$V_{\text{VOC}} = 0.661 \text{ V}$, $T_A = 25^\circ\text{C}$	-12	-	12	A
ERROR COMPONENTS						
Sensitivity Error	E_{SENS}	$T_A = 25^\circ\text{C}$, $T_A = -40^\circ\text{C}$, $T_A = 150^\circ\text{C}$	-3.1	-	3.1	%
Quiescent Voltage Output Error	$V_{\text{QVO_E}}$	$I_{\text{P}} = 0 \text{ A}$; $T_A = 25^\circ\text{C}$, $T_A = -40^\circ\text{C}$, $T_A = 150^\circ\text{C}$	-10	-	10	mV
Sensitivity Temperature Drift	$E_{\text{SENS_T}}$		-	± 1.4	-	%
Quiescent Voltage Output Temperature Drift	$V_{\text{QVO_T}}$		-	± 6	-	mV
Noise	N	$T_A = 25^\circ\text{C}$, $C_{\text{L_VOUT}} = 1 \text{ nF}$, $\text{BW} = 150 \text{ kHz}$	-	4.2	-	mV_{RMS}
Power Supply Offset Error	$V_{\text{OE_PS}}$	$V_{\text{DD}} = 3.15 \text{ V}$, $V_{\text{DD}} = 3.45 \text{ V}$, $T_A = 25^\circ\text{C}$	-15	-	15	mV
Power Supply Sensitivity Error	$E_{\text{SENS_PS}}$	$V_{\text{DD}} = 3.15 \text{ V}$, $V_{\text{DD}} = 3.45 \text{ V}$, $T_A = 25^\circ\text{C}$	-1.5	-	1.5	%
ERROR INCLUDING LIFETIME DRIFT						
Sensitivity Error Including Lifetime Drift [1]	$E_{\text{SENS_LT}}$	Based on six sigma drift of worst-case distribution observed after AEC-Q100 qualification stresses	-4.6	-	4.6	%
Quiescent Voltage Error Including Lifetime Drift [1]	$V_{\text{QVO_LT}}$	Based on six sigma drift of worst-case distribution observed after AEC-Q100 qualification stresses	-18	-	18	mV

[1] Validated by design and characterization.

ACS37220LEZA-150B3 PERFORMANCE CHARACTERISTICS: Valid through the full operating temperature range, $T_A = -40^\circ\text{C}$ to 150°C , $C_{\text{BYPASS}} = 0.1 \mu\text{F}$, and $V_{\text{DD}} = 3.3 \text{ V}$, unless specified otherwise. Minimum and maximum values are tested in production.

Characteristic	Symbol	Test Conditions	Min.	Typ.	Max.	Units
NOMINAL PERFORMANCE						
Current Sensing Range [1]	I_{PR}	Limited by $T_{\text{J(MAX)}} = 165^\circ\text{C}$	-150	-	150	A
Sensitivity	Sens	$I_{\text{PR(MIN)}} < I_{\text{P}} < I_{\text{PR(MAX)}}$	-	8.8	-	mV/A
Quiescent Voltage Output	V_{QVO}	$I_{\text{P}} = 0 \text{ A}$	-	1.65	-	V
Overcurrent FAULT Threshold	I_{OC}	$V_{\text{VOC}} = 0.661 \text{ V}$ or $V_{\text{VOC}} < V_{\text{VOC_L}}$	-	100	-	% I_{PR}
OVERCURRENT FAULT OUTPUT						
Overcurrent FAULT Error	$I_{\text{OC_E}}$	$V_{\text{VOC}} = 0.661 \text{ V}$, $T_A = 25^\circ\text{C}$	-18	-	18	A
ERROR COMPONENTS						
Sensitivity Error	E_{SENS}	$T_A = 25^\circ\text{C}$, $T_A = -40^\circ\text{C}$, $T_A = 150^\circ\text{C}$	-3.1	-	3.1	%
Quiescent Voltage Output Error	$V_{\text{QVO_E}}$	$I_{\text{P}} = 0 \text{ A}$, $T_A = 25^\circ\text{C}$, $T_A = -40^\circ\text{C}$, $T_A = 150^\circ\text{C}$	-10	-	10	mV
Sensitivity Temperature Drift	$E_{\text{SENS_T}}$		-	± 1.4	-	%
Quiescent Voltage Output Temperature Drift	$V_{\text{QVO_T}}$		-	± 6	-	mV
Noise	N	$T_A = 25^\circ\text{C}$, $C_{\text{L_VOU}} = 1 \text{ nF}$, $\text{BW} = 150 \text{ kHz}$	-	2.8	-	mV _{RMS}
Power Supply Offset Error	$V_{\text{OE_PS}}$	$V_{\text{DD}} = 3.15 \text{ V}$, $V_{\text{DD}} = 3.45 \text{ V}$, $T_A = 25^\circ\text{C}$	-15	-	15	mV
Power Supply Sensitivity Error	$E_{\text{SENS_PS}}$	$V_{\text{DD}} = 3.15 \text{ V}$, $V_{\text{DD}} = 3.45 \text{ V}$, $T_A = 25^\circ\text{C}$	-1.5	-	1.5	%
ERROR INCLUDING LIFETIME DRIFT						
Sensitivity Error Including Lifetime Drift [1]	$E_{\text{SENS_LT}}$	Based on six sigma drift of worst-case distribution observed after AEC-Q100 qualification stresses	-4.6	-	4.6	%
Quiescent Voltage Error Including Lifetime Drift [1]	$V_{\text{QVO_LT}}$	Based on six sigma drift of worst-case distribution observed after AEC-Q100 qualification stresses	-18	-	18	mV

[1] Validated by design and characterization.

ACS37220LEZA-100B5 PERFORMANCE CHARACTERISTICS: Valid through the full operating temperature range, $T_A = -40^\circ\text{C}$ to 150°C , $C_{\text{BYPASS}} = 0.1 \mu\text{F}$, and $V_{\text{DD}} = 5 \text{ V}$, unless specified otherwise. Minimum and maximum values are tested in production.

Characteristic	Symbol	Test Conditions	Min.	Typ.	Max.	Units
NOMINAL PERFORMANCE						
Current Sensing Range [1]	I_{PR}	Limited by $T_{\text{J(MAX)}} = 165^\circ\text{C}$	-100	-	100	A
Sensitivity	Sens	$I_{\text{PR(MIN)}} < I_{\text{P}} < I_{\text{PR(MAX)}}$	-	20	-	mV/A
Quiescent Voltage Output	V_{QVO}	$I_{\text{P}} = 0 \text{ A}$	-	2.5	-	V
Overcurrent FAULT Threshold	I_{OC}	$V_{\text{VOC}} = 1 \text{ V}$ or $V_{\text{VOC}} < V_{\text{VOC_L}}$	-	100	-	% I_{PR}
OVERCURRENT FAULT OUTPUT						
Overcurrent FAULT Error	$I_{\text{OC_E}}$	$V_{\text{VOC}} = 1 \text{ V}$, $T_A = 25^\circ\text{C}$	-12	-	12	A
ERROR COMPONENTS						
Sensitivity Error	E_{SENS}	$T_A = 25^\circ\text{C}$, $T_A = -40^\circ\text{C}$, $T_A = 150^\circ\text{C}$	-3.1	-	3.1	%
Quiescent Voltage Output Error	$V_{\text{QVO_E}}$	$I_{\text{P}} = 0 \text{ A}$, $T_A = 25^\circ\text{C}$, $T_A = -40^\circ\text{C}$, $T_A = 150^\circ\text{C}$	-10	-	10	mV
Sensitivity Temperature Drift	$E_{\text{SENS_T}}$		-	± 1.4	-	%
Quiescent Voltage Output Temperature Drift	$V_{\text{QVO_T}}$		-	± 6	-	mV
Noise	N	$T_A = 25^\circ\text{C}$, $C_{\text{L_VOUT}} = 1 \text{ nF}$, $\text{BW} = 150 \text{ kHz}$	-	6.4	-	mV _{RMS}
Power Supply Offset Error	$V_{\text{OE_PS}}$	$V_{\text{DD}} = 4.5 \text{ V}$, $V_{\text{DD}} = 5.5 \text{ V}$, $T_A = 25^\circ\text{C}$	-15	-	15	mV
Power Supply Sensitivity Error	$E_{\text{SENS_PS}}$	$V_{\text{DD}} = 4.5 \text{ V}$, $V_{\text{DD}} = 5.5 \text{ V}$, $T_A = 25^\circ\text{C}$	-1.5	-	1.5	%
ERROR INCLUDING LIFETIME DRIFT						
Sensitivity Error Including Lifetime Drift [1]	$E_{\text{SENS_LT}}$	Based on six sigma drift of worst-case distribution observed after AEC-Q100 qualification stresses	-4.6	-	4.6	%
Quiescent Voltage Error Including Lifetime Drift [1]	$V_{\text{QVO_LT}}$	Based on six sigma drift of worst-case distribution observed after AEC-Q100 qualification stresses	-18	-	18	mV

[1] Validated by design and characterization.

ACS37220LEZA-150B5 PERFORMANCE CHARACTERISTICS: Valid through the full operating temperature range, $T_A = -40^\circ\text{C}$ to 150°C , $C_{\text{BYPASS}} = 0.1 \mu\text{F}$, and $V_{\text{DD}} = 5 \text{ V}$, unless specified otherwise. Minimum and maximum values are tested in production.

Characteristic	Symbol	Test Conditions	Min.	Typ.	Max.	Units
NOMINAL PERFORMANCE						
Current Sensing Range [1]	I_{PR}	Limited by $T_{\text{J(MAX)}} = 165^\circ\text{C}$	-150	-	150	A
Sensitivity	Sens	$I_{\text{PR(MIN)}} < I_{\text{P}} < I_{\text{PR(MAX)}}$	-	13.3	-	mV/A
Quiescent Voltage Output	V_{QVO}	$I_{\text{P}} = 0 \text{ A}$	-	2.5	-	V
Overcurrent FAULT Threshold	I_{OC}	$V_{\text{VOC}} = 1 \text{ V}$ or $V_{\text{VOC}} < V_{\text{VOC_L}}$	-	100	-	% I_{PR}
OVERCURRENT FAULT OUTPUT						
Overcurrent FAULT Error	$I_{\text{OC_E}}$	$V_{\text{VOC}} = 1 \text{ V}$, $T_A = 25^\circ\text{C}$	-18	-	18	A
ERROR COMPONENTS						
Sensitivity Error	E_{SENS}	$T_A = 25^\circ\text{C}$, $T_A = -40^\circ\text{C}$, $T_A = 150^\circ\text{C}$	-3.1	-	3.1	%
Quiescent Voltage Output Error	$V_{\text{QVO_E}}$	$I_{\text{P}} = 0 \text{ A}$, $T_A = 25^\circ\text{C}$, $T_A = -40^\circ\text{C}$, $T_A = 150^\circ\text{C}$	-10	-	10	mV
Sensitivity Temperature Drift	$E_{\text{SENS_T}}$		-	± 1.4	-	%
Quiescent Voltage Output Temperature Drift	$V_{\text{QVO_T}}$		-	± 6	-	mV
Noise	N	$T_A = 25^\circ\text{C}$, $C_{\text{L_VOU}} = 1 \text{ nF}$, $\text{BW} = 150 \text{ kHz}$	-	4.2	-	mV_{RMS}
Power Supply Offset Error	$V_{\text{OE_PS}}$	$V_{\text{DD}} = 4.5 \text{ V}$, $V_{\text{DD}} = 5.5 \text{ V}$, $T_A = 25^\circ\text{C}$	-15	-	15	mV
Power Supply Sensitivity Error	$E_{\text{SENS_PS}}$	$V_{\text{DD}} = 4.5 \text{ V}$, $V_{\text{DD}} = 5.5 \text{ V}$, $T_A = 25^\circ\text{C}$	-1.5	-	1.5	%
ERROR INCLUDING LIFETIME DRIFT						
Sensitivity Error Including Lifetime Drift [1]	$E_{\text{SENS_LT}}$	Based on six sigma drift of worst-case distribution observed after AEC-Q100 qualification stresses	-4.6	-	4.6	%
Quiescent Voltage Error Including Lifetime Drift [1]	$V_{\text{QVO_LT}}$	Based on six sigma drift of worst-case distribution observed after AEC-Q100 qualification stresses	-18	-	18	mV

[1] Validated by design and characterization.

ACS37220LEZATR-200B5 PERFORMANCE CHARACTERISTICS: Valid through the full operating temperature range, $T_A = -40^\circ\text{C}$ to 150°C , $C_{\text{BYPASS}} = 0.1\mu\text{F}$, and $V_{\text{DD}} = 5\text{V}$, unless specified otherwise. Minimum and maximum values are tested in production.

Characteristic	Symbol	Test Conditions	Min.	Typ.	Max.	Units
NOMINAL PERFORMANCE						
Current Sensing Range [1]	I_{PR}	Limited by $T_{\text{J(MAX)}} = 165^\circ\text{C}$	-200	-	200	A
Sensitivity	Sens	$I_{\text{PR(MIN)}} < I_{\text{P}} < I_{\text{PR(MAX)}}$	-	10	-	mV/A
Quiescent Voltage Output	V_{QVO}	$I_{\text{P}} = 0\text{ A}$	-	2.5	-	V
Overcurrent FAULT Threshold	I_{OC}	$V_{\text{VOC}} = 1\text{ V}$ or $V_{\text{VOC}} < V_{\text{VOC_L}}$	-	100	-	% I_{PR}
OVERCURRENT FAULT OUTPUT						
Overcurrent FAULT Error	$I_{\text{OC_E}}$	$V_{\text{VOC}} = 1\text{ V}$, $T_A = 25^\circ\text{C}$	-24	-	24	A
ERROR COMPONENTS						
Sensitivity Error	E_{SENS}	$T_A = 25^\circ\text{C}$, $T_A = -40^\circ\text{C}$, $T_A = 150^\circ\text{C}$	-3.1	-	3.1	%
Quiescent Voltage Output Error	$V_{\text{QVO_E}}$	$I_{\text{P}} = 0\text{ A}$, $T_A = 25^\circ\text{C}$, $T_A = -40^\circ\text{C}$, $T_A = 150^\circ\text{C}$	-10	-	10	mV
Sensitivity Temperature Drift	$E_{\text{SENS_T}}$		-	± 1.4	-	%
Quiescent Voltage Output Temperature Drift	$V_{\text{QVO_T}}$		-	± 6	-	mV
Noise	N	$T_A = 25^\circ\text{C}$, $C_{\text{L_VOU}} = 1\text{ nF}$, $\text{BW} = 150\text{ kHz}$	-	3.2	-	mV_{RMS}
Power Supply Offset Error	$V_{\text{OE_PS}}$	$V_{\text{DD}} = 4.5\text{ V}$, $V_{\text{DD}} = 5.5\text{ V}$, $T_A = 25^\circ\text{C}$	-15	-	15	mV
Power Supply Sensitivity Error	$E_{\text{SENS_PS}}$	$V_{\text{DD}} = 4.5\text{ V}$, $V_{\text{DD}} = 5.5\text{ V}$, $T_A = 25^\circ\text{C}$	-1.5	-	1.5	%
ERROR INCLUDING LIFETIME DRIFT						
Sensitivity Error Including Lifetime Drift [1]	$E_{\text{SENS_H_LT}}$	Based on six sigma drift of worst-case distribution observed after AEC-Q100 qualification stresses	-4.6	-	4.6	%
Quiescent Voltage Error Including Lifetime Drift [1]	$V_{\text{QVO_LT}}$	Based on six sigma drift of worst-case distribution observed after AEC-Q100 qualification stresses	-18	-	18	mV

[1] Validated by design and characterization.

ACS37220 TYPICAL FREQUENCY RESPONSE

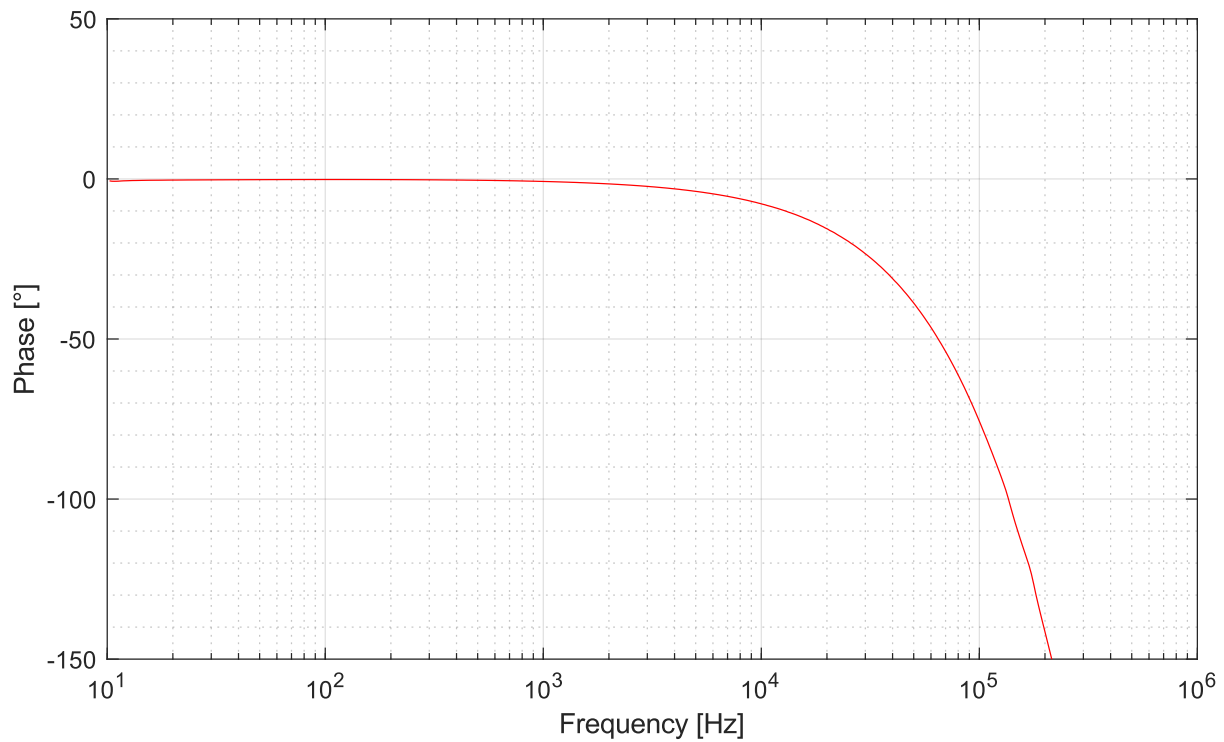
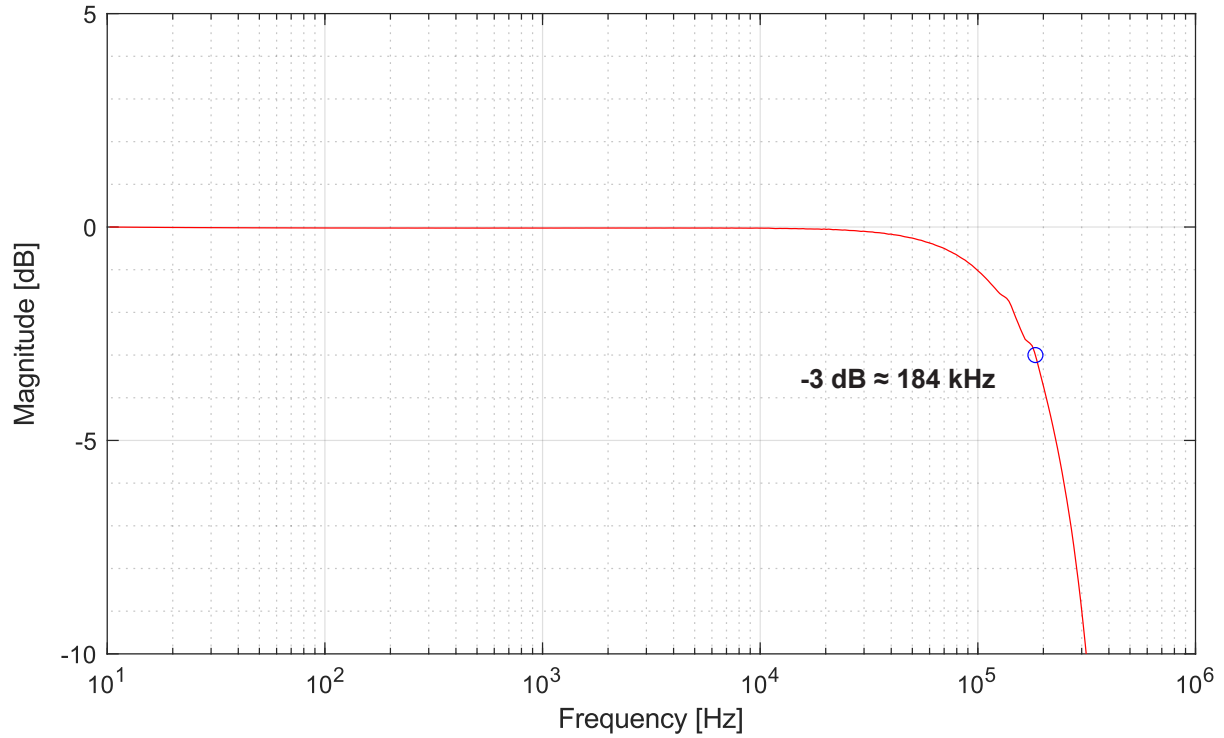

RESPONSE CHARACTERISTICS DEFINITIONS AND PERFORMANCE DATA

Response Time (t_{RESP})

The time interval between a) when the sensed input current reaches 90% of its full-scale value, and b) when the sensor output, V_{OUT} , reaches 90% of its full-scale output value.

Rise Time (t_R)

The time interval between a) when the sensor output, V_{OUT} , reaches 10% of its full-scale value, and b) when the sensor output, V_{OUT} , reaches 90% of its full-scale value.

Propagation Delay (t_{PD})

The time interval between a) when the sensed input current reaches 20% of its full-scale value, and b) when the sensor output, V_{OUT} , reaches 20% of its full-scale output value.

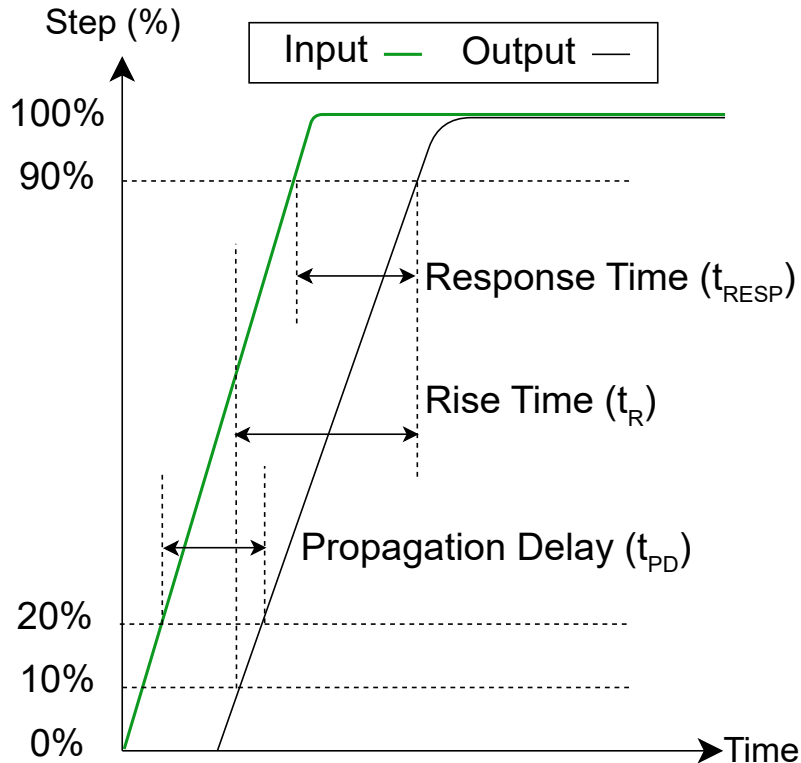

Figure 4: Step Response Characteristics

FUNCTIONAL DESCRIPTION OF POWER ON/OFF OPERATION

Introduction

The graphs in this section show the behavior of V_{OUT} as V_{DD} reaches or falls below the required power-on voltage. Figure 5 and Figure 6 use the same labeling convention for different voltage thresholds. References in brackets “[]” are valid for each of these graphs.

POWER-ON OPERATION

As V_{DD} ramps up, the V_{OUT} pin is in a high-impedance (high-Z) state until V_{DD} reaches and passes V_{POR} [1]. Once V_{DD} has passed V_{POR} [1], V_{OUT} enters normal operation and starts responding to applied current, I_P .

POWER-OFF OPERATION

As V_{DD} drops below $V_{POR} - V_{POR_HYS}$ the outputs enters a high-Z state. The hysteresis on the power-on voltage prevents noise on the supply line from causing V_{OUT} to repeatedly enter and exit the high-Z state around the V_{POR} level.

NOTE: Because the device is entering a high-Z state and not driving the output, the time it takes the output to reach a steady state depends on the external circuitry.

Voltage Thresholds

POWER-ON RESET RELEASE VOLTAGE (V_{POR})

If V_{DD} falls below $V_{POR} - V_{POR_HYS}$ [2] while the sensor is in operation, the digital circuitry turns off and the output re-enters a high-Z state. After V_{DD} recovers and exceeds V_{POR} [1], the output enters normal operation after a delay of t_{PO} .

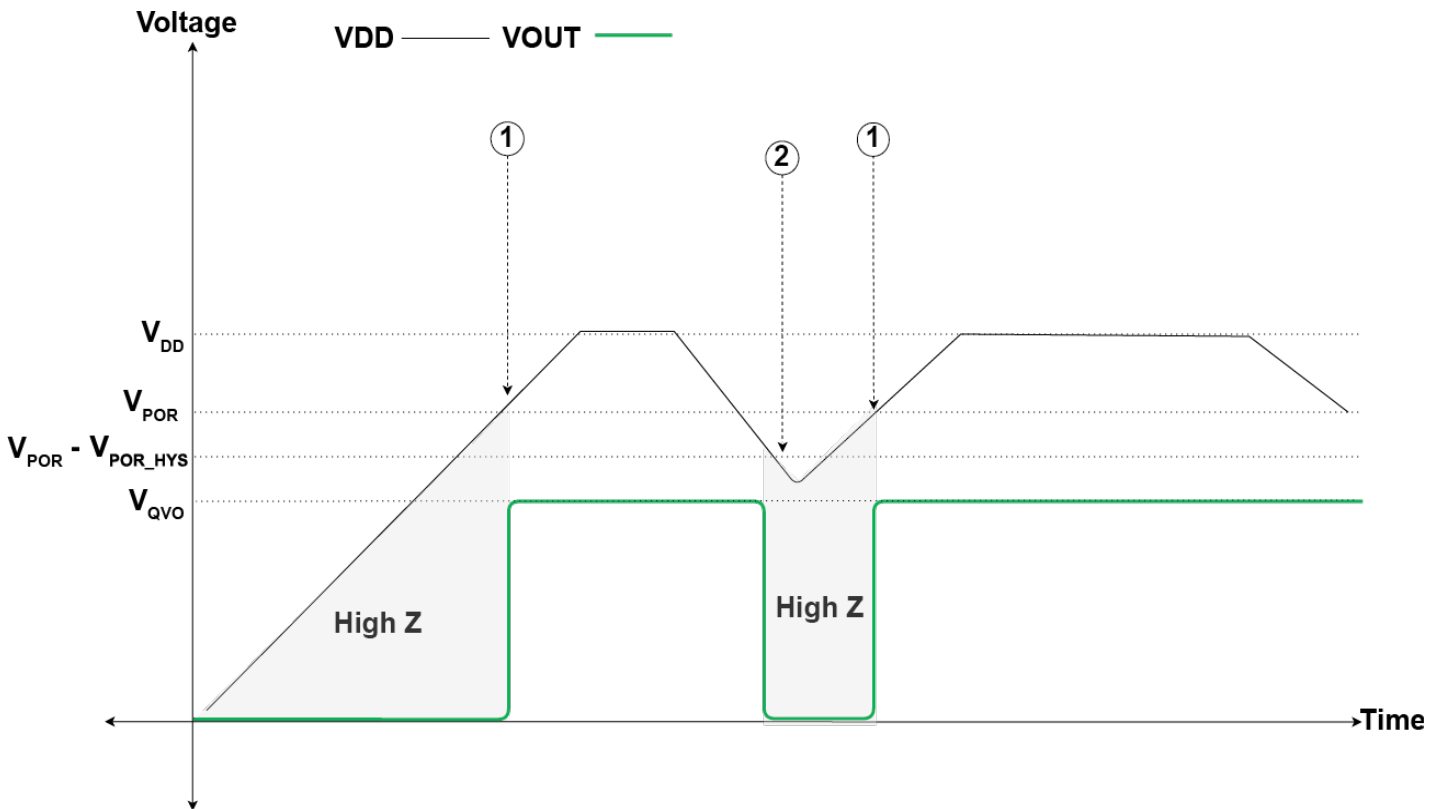

Figure 5: Power-On And Power-Off Operation

Timing Thresholds

POWER-ON DELAY (t_{PO})

When the supply voltage reaches V_{POR} [1], the device requires a finite time to power its internal components before the outputs are released from the high-impedance state and start responding to the measured current, I_p . Power-On Time, t_{PO} , is defined as the time it takes for the output voltage to settle within $\pm 10\%$ of its steady-state value under an applied current, I_p , which can be seen as the time from [1] to [A] in Figure 6.

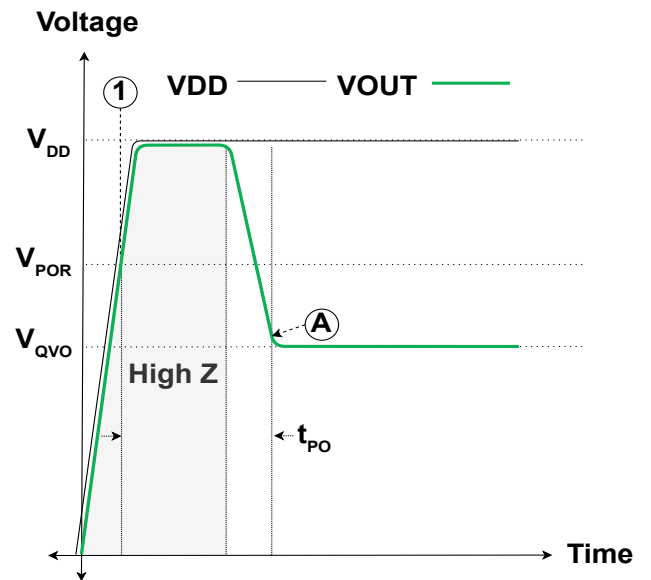

Figure 6: Power-On Delay, t_{PO}

DEFINITIONS OF OPERATING AND PERFORMANCE CHARACTERISTICS

Quiescent Voltage Output (V_{QVO})

Quiescent Voltage Output, V_{QVO} , is defined as the voltage on the output, V_{OUT} , when no current is applied, $I_P = 0$.

Quiescent Voltage Output Error (V_{QVO_E})

Quiescent Voltage Output Error, V_{QVO_E} , is defined as the deviation of V_{QVO} from the nominal target value in production testing.

Quiescent Voltage Output Temperature Drift (V_{QVO_T})

Quiescent Voltage Output Temperature Drift, V_{QVO_T} , is defined as the expected deviation of V_{QVO} from its value at $T_A = 25^\circ\text{C}$ over the temperature range $T_A = -40$ to 150°C , based on observed three-sigma temperature drifts.

Output Saturation Voltage (V_{SAT_H} and V_{SAT_L})

Output Saturation Voltage, V_{SAT} , is defined as the low or high voltage that V_{OUT} does not exceed. V_{SAT_H} is the highest voltage the output can reach, while V_{SAT_L} is the lowest. Note that changing the sensitivity does not change the V_{SAT} points.

Sensitivity (Sens)

Sensitivity, or Sens, is defined as the ratio of the V_{OUT} swing and the current through the primary conductor, I_P . The current causes a voltage change on V_{OUT} away from V_{QVO} until V_{SAT} . The magnitude and direction of the output voltage is proportional to the magnitude and direction of the current, I_P . The proportional relationship between output voltage and current is Sensitivity, defined as:

$$Sens = [V_{OUT}(I_{P1}) - V_{OUT}(I_{P2})] / [I_{P1} - I_{P2}]$$

where I_{P1} and I_{P2} are two different currents, and $V_{OUT}(I_{P1})$ and $V_{OUT}(I_{P2})$ are the respective output voltages, at V_{OUT} , at those currents.

Sensitivity Error (E_{SENS})

Sensitivity Error, E_{SENS} , is the deviation of Sensitivity from the nominal sensitivity target value in production testing.

Sensitivity Temperature Drift (E_{SENS_T})

Sensitivity Temperature Drift, E_{SENS_T} , is defined as the expected deviation of Sens from its value at $T_A = 25^\circ\text{C}$ over the temperature range $T_A = -40$ to 150°C , based on observed three-sigma temperature drifts.

Error Including Lifetime Drift (E_{SENS_LT} and V_{QVO_LT})

Lifetime drift characteristics are based on a statistical combination of production distributions and six-sigma drift in the worst-case distribution observed during AEC-Q100 qualification stresses. Solder reflow induces stress and lifetime drift limits apply immediately after solder reflow.

Power Supply Sensitivity Error (E_{SENS_PS})

Power Supply Sensitivity Error, E_{SENS_PS} , is defined as the percent change in Sens when V_{DD} varies within the specified test voltages.

Power Supply Offset Error (V_{OE_PS})

Power Supply Offset Error, V_{OE_PS} , is defined as the change in V_{QVO} when V_{DD} varies within the specified test voltages.

OVERCURRENT FAULT (OCF) FUNCTION

The Overcurrent FAULT (OCF) function pulls the open-drain FAULT pin low when the applied current, I_p , exceeds a set threshold, I_{OCR} . The threshold is adjustable via the VOC pin. Overcurrent FAULT activates symmetrically for positive and negative applied currents.

VOLTAGE OVERCURRENT PIN (VOC)

The Voltage Overcurrent pin, or VOC, is a voltage input that is used to set the Overcurrent FAULT Threshold, I_{OCR} . There are two ways to set the threshold: 1) via a resistor, R_{VOC} , between VOC and GND, or 2) by an external low-impedance voltage source connected to VOC.

The sensor has an internal factory-calibrated 10 μ A current source at VOC. Connecting a resistor between VOC and GND sets the voltage at VOC via $V_{VOC} [V] = R_{VOC} [\Omega] \times 10 [\mu A]$. R_{VOC} must be chosen such that V_{VOC} is between 0.5 V and 2 V for 5 V supply variants, or between 0.33 V and 1.321 V for 3.3 V supply variants. The relationship between V_{VOC} and I_{OCR} is shown in Table 1. I_{OCR} is set as a percentage of the full-scale sensing range of the device, $I_{PR(MAX)}$, and can be between 50% $I_{PR(MAX)}$ and 200% $I_{PR(MAX)}$.

Additionally, the VOC pin has an internal voltage comparator and when $V_{VOC} < V_{VOC_L}$, the device internally sets $I_{OCR} = 100\% I_{PR(MAX)}$.

Table 1: FAULT threshold, I_{OCR} , as set by V_{VOC}

$V_{VOC} (V)$		$I_{OCR} (\%I_{PR(MAX)})$
5 V variants	3.3 V variants	
$< V_{VOC_L}$		100
0.5	0.33	50
0.75	0.466	75
1	0.661	100
1.25	0.86	125
1.5	0.991	150
1.75	1.156	175
2	1.321	200

The voltage at VOC can also be set using an external low-impedance voltage source that overdrives the internal 10 μ A current supply. If the application does not require the threshold to be adjusted once the sensor is in operation, it is recommended to use a low-tolerance resistor for fixing I_{OCR} .

VOC INPUT LINEAR OPERATING RANGE (V_{OR_VOC})

VOC Input Linear Operating Range, V_{OR_VOC} , is the voltage range for V_{VOC} in which the Overcurrent FAULT Threshold, I_{OCR} , varies linearly with V_{VOC} . I_{OCR} can be set between 50% $I_{PR(MAX)}$ and 200% $I_{PR(MAX)}$ within the VOC Input Linear Operating Range, V_{OR_VOC} .

VOC INPUT LOW VOLTAGE (V_{VOC_L})

VOC Input Low Voltage, V_{VOC_L} , is defined as the voltage at the VOC pin below which the Overcurrent FAULT Threshold, I_{OCR} , is internally set to $I_{OCR} = 100\% I_{PR(MAX)}$.

OVERCURRENT FAULT OUTPUT ERROR (E_{OC})

Overcurrent FAULT Error, E_{OC} , is defined as the difference between the set threshold, I_{OCR} , and the measured current, I_p , at which Overcurrent FAULT activates.

OVERCURRENT FAULT HYSTERESIS (I_{OC_HYS})

Overcurrent FAULT Hysteresis, I_{OC_HYS} , is defined as the required decrease of I_p , in percentage of $I_{PR(MAX)}$, before assertion at the FAULT pin is cleared. This can be seen as the difference between the levels [9] and [10] in Figure 7.

OVERCURRENT FAULT RESPONSE TIME (t_{OC_RESP})

Overcurrent FAULT Response Time, t_{OC_RESP} , is defined as the time between the current reaching the set I_{OCR} and the FAULT pin falling below V_{FAULT_L} .

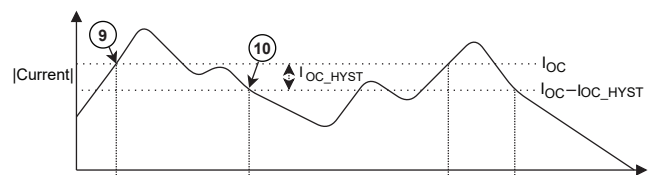

Figure 7: Overcurrent FAULT Hysteresis

LAYOUT GUIDELINES

Introduction

Current should be distributed over all available copper layers of the printed circuit board (PCB). Using in-pad vias avoids the current being conducted primarily through the top layer of the PCB, which would result in higher power dissipation and lower heat conduction. It is recommended to use an 8-layer PCB stack-up, or at least 4 layers with 2 oz copper. See the “Thermal Performance” section of the datasheet for additional application information regarding thermal management.

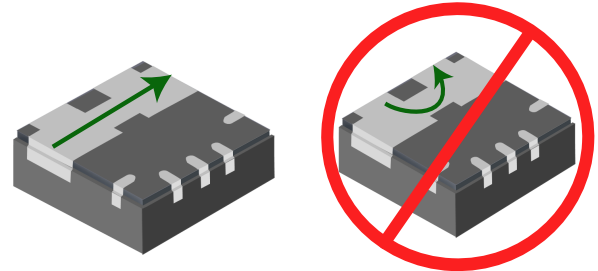

Figure 9: Recommended current flow through the EZ package

Solder Stencil Grid

Voids in the solder on the current conductor pads (IP+ and IP-) increase the resistance of the solder joints and reduce the heat conduction to the PCB. Voids should be minimized in the solder joints under the sensor. Voids can develop from solder flux outgassing. Trapped gas needs to be given a way to escape from under the package during solder reflow. Adding a grid in the solder stencil helps create a path for outgassing during the wetting process of the reflow. See Figure 8 for an example solder stencil.

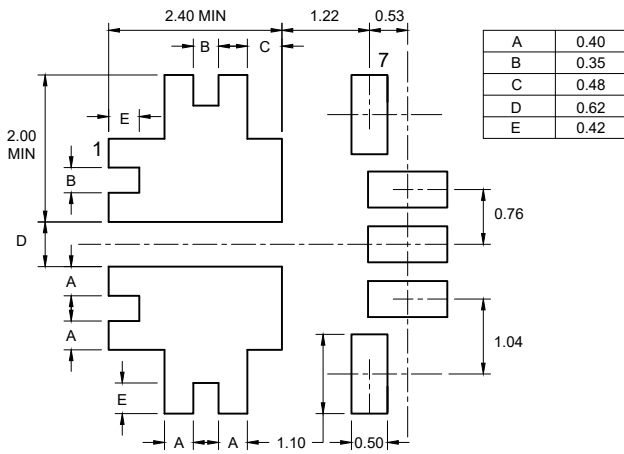

Figure 8: Example solder stencil for EZ package

Flow of Current Through the EZ Package

The sensor is calibrated for current flowing in a straight line through the package. To achieve sensitivity accuracy, the current flow from pin 1 to pin 2 (IP+ to IP-), must follow a straight path (Figure 9). To achieve this, it is recommended to leave at least 14 mm × 14 mm straight conductor trace on both sides of the sensor, leading into and out of the IP pins, with the sensor placed in the middle of the traces (See Figure 10).

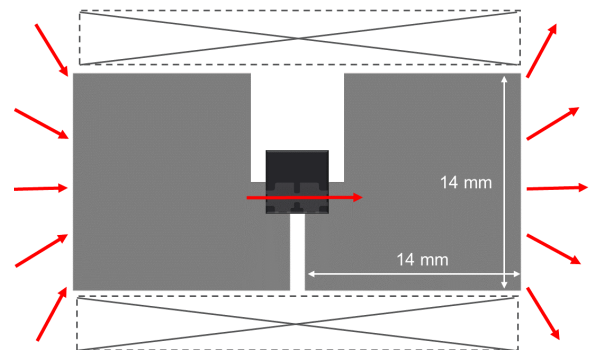

Figure 10: Recommended trace layout for the IP+ and IP- pins

EZ Package Layout Recommendations

In order to minimize heat sinking on the signal-side of the sensor, the GND and VDD pins should not be connected by a direct via to a ground or power layer. Instead, signal pins should have a narrow trace with at least 4 mm length. This ensures low heat conduction on the signal side of the package and prevents thermal gradients on the die.

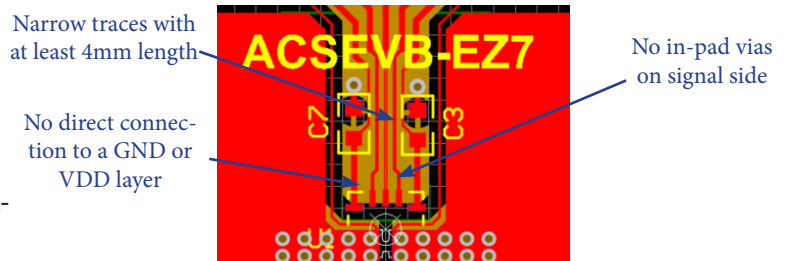

Figure 11: Top layer of EZ package evaluation board

THERMAL PERFORMANCE

In-Pad Vias and Thermal Management

Resistive heating due to the flow of electrical current in the package should be considered during the thermal design of the application. The sensor, PCB, and PCB terminals generate heat and act as a heat sink.

The thermal response is highly dependent on the PCB layout, copper thickness, cooling method, and the profile of the injected current (including peak current, current on-time, and duty cycle).

In-pad vias help improve thermal performance. Placing vias under the copper pads of the ACS37220 reduces electrical resistance and improves heat conduction to the PCB (Figure 12 and Figure 13). The EZ Current Sensor Evaluation Board is designed to include in-pad vias.

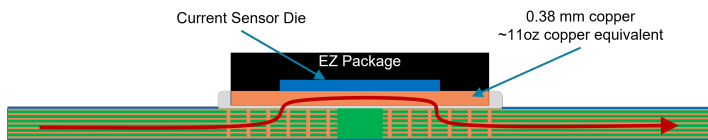

Figure 12: In-Pad Vias

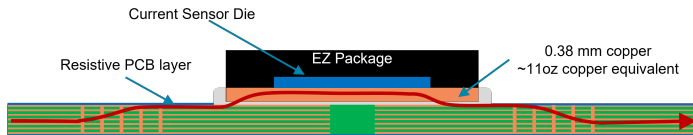

Figure 13: No In-Pad Vias

Figure 14 shows the measured rise in steady-state die temperature of ACS37220 versus DC continuous current at an ambient temperature $T_A = 25^\circ\text{C}$ for two board designs: with filled in-pad vias and without in-pad vias.

Figure 15 shows the measured rise in steady-state die temperature of ACS37220 versus DC continuous current at ambient temperatures of 25°C and 125°C .

The thermal performance of ACS37220 must always be verified in the specific conditions of the application. The maximum junction temperature of the sensor, $T_{J(\text{MAX})} = 165^\circ\text{C}$, must not be exceeded.

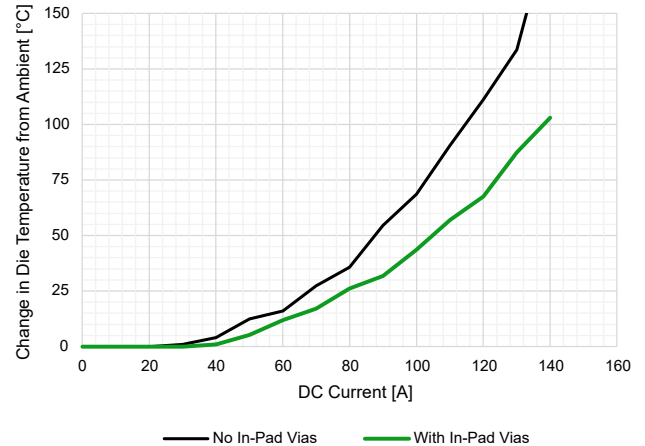

Figure 14: Comparison of die-temperature increase with and without in-pad vias at $T_A = 25^\circ\text{C}$

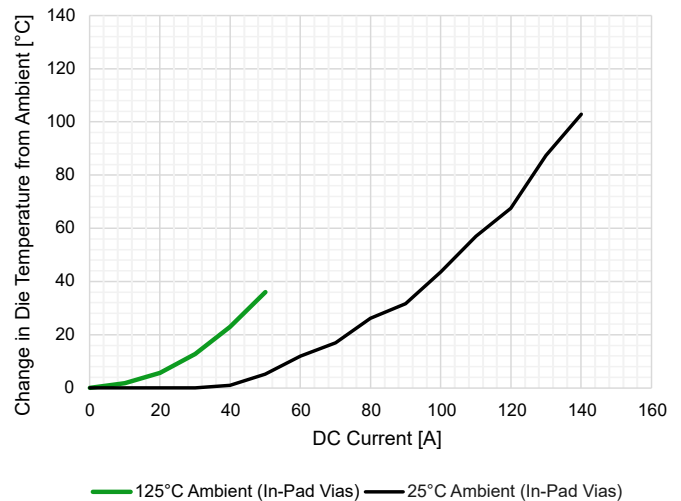

Figure 15: Comparison of die-temperature increase at $T_A = 25^\circ\text{C}$ and $T_A = 125^\circ\text{C}$ with in-pad vias

Evaluation Board Layout

Thermal data was collected using the EZ Current Sensor Evaluation Board (ACSEVB-EZ7, TED-0004114) shown in Figure 16.

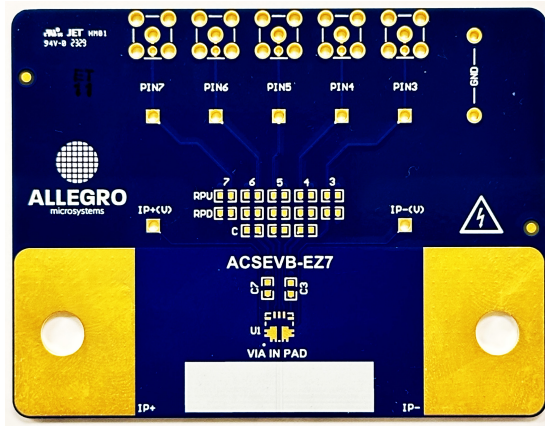
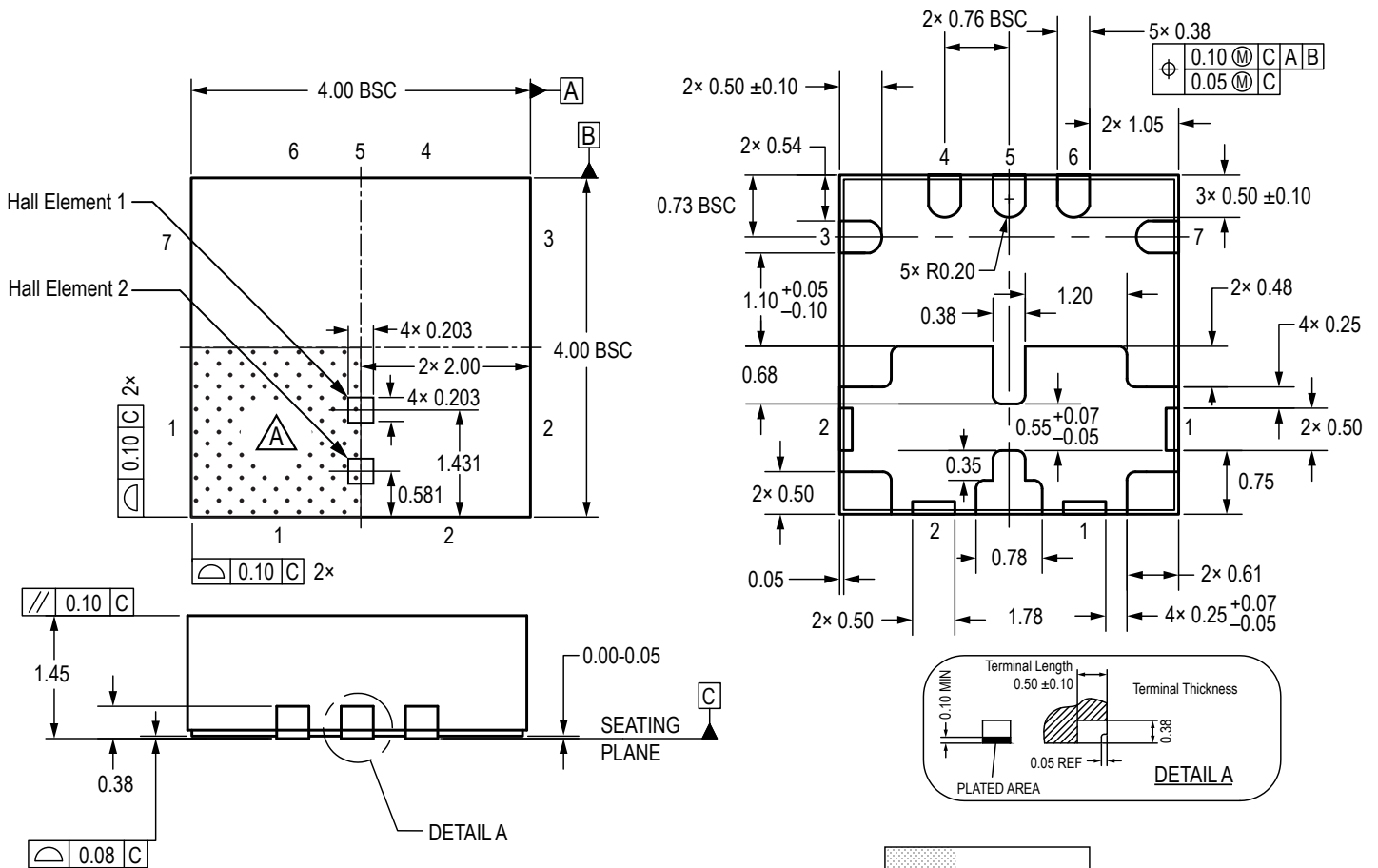

Figure 16: EZ Package Allegro Evaluation Board

Design support files for the ACSEVB-EZ7 evaluation board are available for download from the Allegro website. See the technical documents section of the ACS37220 website for more information.

PACKAGE OUTLINE DRAWING



For Reference Only; not for tooling use
 (Reference Allegro DWG-0000853, Rev. 2, PRELIMINARY)
 Dimensions in millimeters; unspecified tolerances are ±0.05 mm
 Exact case and lead configuration at supplier discretion within limits shown

A Terminal #1 mark area

B Branding scale and appearance at supplier discretion

B Standard Branding Reference View

Line 1: Part Number
 Line 2: 4-Digit Date Code
 Line 3: Characters 5, 6, 7, 8 of Assembly Lot Number

Pin 1 Dot top left
 Center align

Figure 17: 7-pin QFN with Wettable Flank (Suffix EZ)

Revision History

Number	Date	Description
–	February 16, 2024	Initial release

Copyright 2024, Allegro MicroSystems.

Allegro MicroSystems reserves the right to make, from time to time, such departures from the detail specifications as may be required to permit improvements in the performance, reliability, or manufacturability of its products. Before placing an order, the user is cautioned to verify that the information being relied upon is current.

Allegro's products are not to be used in any devices or systems, including but not limited to life support devices or systems, in which a failure of Allegro's product can reasonably be expected to cause bodily harm.

The information included herein is believed to be accurate and reliable. However, Allegro MicroSystems assumes no responsibility for its use; nor for any infringement of patents or other rights of third parties which may result from its use.

Copies of this document are considered uncontrolled documents.

For the latest version of this document, visit our website:

www.allegromicro.com

Looking for pricing, stock, or lifecycle information?

Click below to explore more details on WIN SOURCE:

- ⊖ [View ACS37220LEZATR-150B3 on WIN SOURCE](#)
- ⊖ [Allegro MicroSystems, LLC Information](#)

Optimize Your Supply Chain with WIN SOURCE Solutions

- ✓ Global Sourcing Solution
- ✓ Obsolete Management
- ✓ Cost Control Management
- ✓ Shortage Management
- ✓ Alternative Solution
- ✓ Excess Inventory Management