



THE DATASHEET OF TPS16850VMAR



Features

- Supply Voltage: $\pm 3.3V$ to $\pm 8V$ or $3.3V$ to $16V$
- Low ON-State Resistance:
typical 4.5Ω at $V_s = \pm 5V$
- Bandwidth: 150 MHz
- Fast switching times: $t_{ON} = 200\text{ns}$, $t_{OFF} = 130\text{ns}$ at $V_s = \pm 5V$
- Break-Before-Make Switching
- Operation Temperature Range: -40°C to 125°C

Applications

- Industry control systems
- Battery-powered systems
- Audio Signal Routing
- Instrumentation

Description

The TPW4425 is a four channel single-pole dual-throw analog switch (SPDT) suitable for use in analog or multiplexer / de-multiplexer applications.

The device is designed on an enhanced process that provides lower power dissipation yet gives high switching speeds. These devices can operate equally well as either multiplexers or de-multiplexers and have an input range that extends to the supplies. All channels exhibit break-before-make switching action, preventing momentary shorting when switching channels.

Table of Contents

Features	1
Applications	1
Description	1
Table of Contents	2
Revision History	4
Order Information	4
Pin Configuration, Description and Functional Table ^{Note 1}	5
TPW4425, 4ch SPDT	5
Absolute Maximum Ratings ^{Note 1}	7
ESD Rating	7
Recommended Operating Conditions ^{Note 1}	7
Electrical Characteristics	8
Dual Supply, $V_{CC} = 5V$, $V_{EE} = -8V$, $GND = 0V$, unless otherwise noted.	8
Dual Supply, $V_{CC} = 4.5$ to $5.5V$, $V_{EE} = -4.5$ to $5.5V$, $GND = 0V$, unless otherwise noted.	9
Single Supply, $V_{CC} = 10.8V$ to $13.2V$, $V_{EE} = 0V$, $GND = 0V$, unless otherwise noted.	10
Single Supply, $V_{CC} = 4.5V$ to $5.5V$, $V_{EE} = 0V$, $GND = 0V$, unless otherwise noted.	11
Single Supply, $V_{CC} = 3.3V$, $V_{EE} = 0V$, $GND = 0V$, unless otherwise noted.	12
Single Supply, $V_{CC} = 16V$, $V_{EE} = 0V$, $GND = 0V$, unless otherwise noted.	13
Typical Performance Characteristics	14
Test Circuit and Waveforms	15
Application Information	17
Tape and Reel Information	18
Package Outline Dimensions	19
TSSOP20	19
IMPORTANT NOTICE AND DISCLAIMER	20

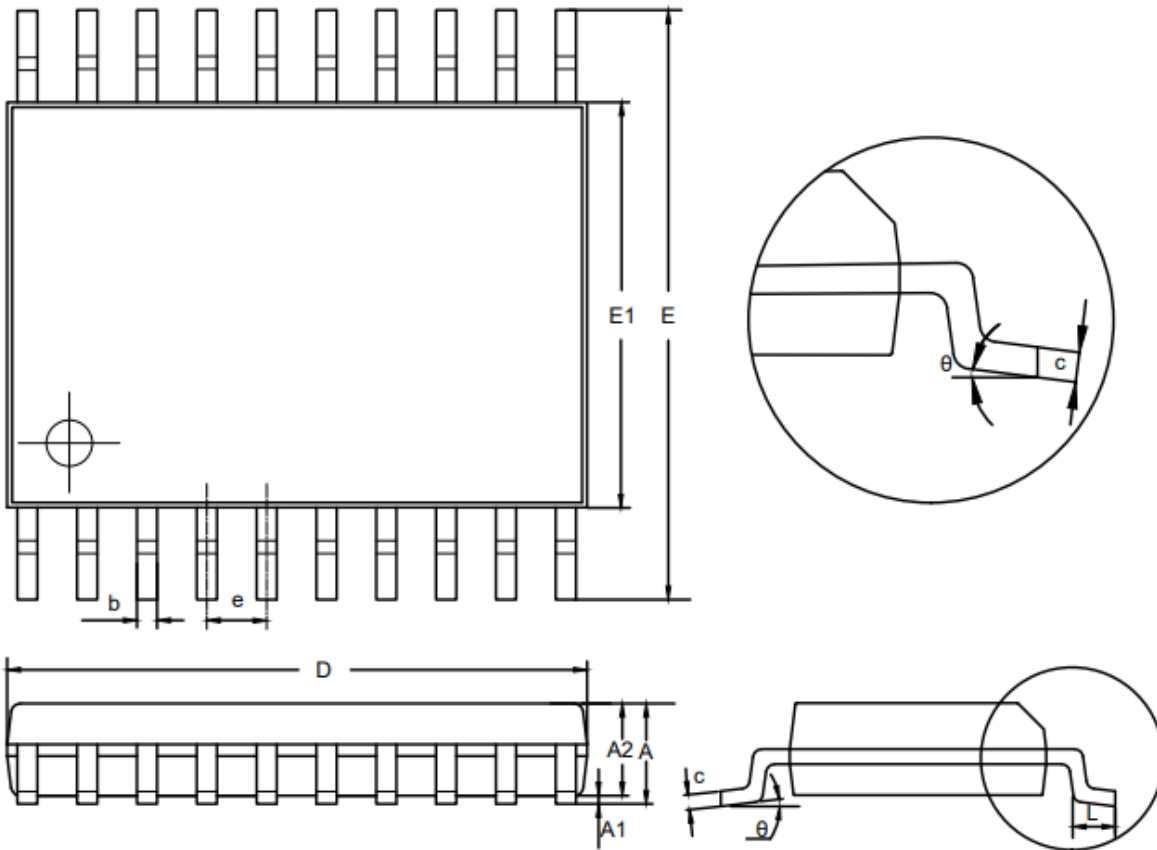

Symbol	Dimensions In Millimeters		Dimensions In Inches	
	MIN	MAX	MIN	MAX
A	0.900	1.200	0.035	0.047
A1	0.050	0.150	0.002	0.006
A2	0.800	1.050	0.031	0.041
b	0.190	0.300	0.007	0.012
c	0.090	0.200	0.004	0.008
D	6.400	6.600	0.252	0.260
E	6.200	6.600	0.244	0.260
E1	4.300	4.500	0.169	0.177
e	0.650 BSC		0.026 BSC	
L	0.450	0.750	0.018	0.030
θ	0	8°	0	8°

NOTES

1. Do not include mold flash or protrusion.
2. This drawing is subject to change without notice.

..... 19

Package Outline Dimensions 20

 QFN-20 20

IMPORTANT NOTICE AND DISCLAIMER 21

Revision History

Date	Revision	Notes
2020/7/31	Rev.Pre	Pre-released version
2020/9/15	Rev.Pre.1	Updated Tape and Reel Information: P0: 4->8, Pin1: Q1->Q2
2020/12/20	Rev.A.0	Released version
2021/10/18	Rev.A.1	Updated the absolute rating of Digital Input Voltage, /E, S2, S1, S0, INx
2023/04/21	Rev.A.2	Added the pin description, the exposed pad is tied to the V _{EE} .

Order Information

Order Number	Operating Temperature Range	Package	Marking Information	MSL	Transport Media, Quantity
TPW4425-QFKR	-40 to 125°C	20-Pin QFN 4*4mm	W4425	3	Tape and Reel, 3000
TPW4425-TS4R ^{Note 1}	-40 to 125°C	TSSOP-20	W4425	3	Tape and Reel, 4000

Note 1: Future product, contact 3PEAK factory for more information and sample

Pin Configuration, Description and Functional Table ^{Note 1}

TPW4425, 4ch SPDT

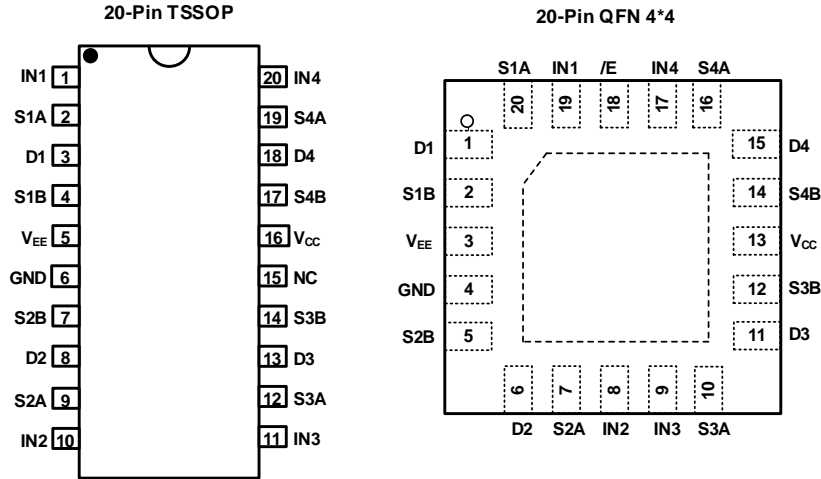

Note: The exposed pad is tied to the V_{EE}

Pin Functions

Pin			I/O	Description
TSSOP20	QFN-20L	Name		
1	19	IN1	I	Logic Control Input 1.
2	20	S1A	IO	Source Terminal 1A. Can be an input or an output.
3	1	D1	IO	Drain Terminal 1. Can be an input or an output.
4	2	S1B	IO	Source Terminal 1B. Can be an input or an output.
5	3	V _{EE}	-	Most Negative Power Supply Potential. In single-supply applications, this pin can be connected to ground.
6	4	GND	-	Ground (0 V) Reference.
7	5	S2B	IO	Source Terminal 2B. Can be an input or an output.
8	6	D2	IO	Drain Terminal 2. Can be an input or an output.
9	7	S2A	IO	Source Terminal 2A. Can be an input or an output.
10	8	IN2	I	Logic Control Input 2.
11	9	IN3	I	Logic Control Input 3.
12	10	S3A	IO	Source Terminal 3A. Can be an input or an output.
13	11	D3	IO	Drain Terminal 3. Can be an input or an output.

14	12	S3B	IO	Source Terminal 3B. Can be an input or an output.
15	N/A	NC	-	No Connect.
16	13	V _{CC}	-	Most Positive Power Supply Potential.
17	14	S4B	IO	Source Terminal 4B. Can be an input or an output.
18	15	D4	IO	Drain Terminal 4. Can be an input or an output.
19	16	S4A	IO	Source Terminal 4A. Can be an input or an output.
20	17	IN4	I	Logic Control Input 4.
N/A	18	/E	I	Active Low Digital Input. When this pin is high, the device is disabled and all switches are off. When this pin is low, INx logic inputs determine the on switches.
N/A	21	EP	-	Exposed Pad. The exposed pad is tied to the V _{EE} .

Functional Table

/E	Inx	SxA	SxB
1	X	OFF	OFF
0	0	OFF	ON
0	1	ON	OFF

X = Don't care

Absolute Maximum Ratings ^{Note 1}

Parameters	Rating
Supply Voltage, $V_{CC} - V_{EE}$	-0.5V to 18V
Analog Switch Voltage	$V_{EE} - 0.5V$ to $V_{CC} + 0.5V$
Analog Switch Current	$\pm 200mA$
Analog Switch Diode Current	$\pm 20mA$
Digital Input Voltage, /E, S2, S1, S0, INx	GND-0.3V to $V_{CC} + 0.5V$
Digital Input Diode Current	$\pm 20mA$
Maximum Junction Temperature	150°C
Storage Temperature Range	-65 to 150°C
Lead Temperature (Soldering, 10 sec)	260°C

Note 1: Stresses beyond those listed under Absolute Maximum Ratings may cause permanent damage to the device. Exposure to any Absolute Maximum Rating condition for extended periods may affect device reliability and lifetime.

ESD Rating

Symbol	Parameter	Condition	Minimum Level	Unit
HBM	Human Body Model ESD	ANSI/ESDA/JEDEC JS-001	4	kV
CDM	Charged Device Model ESD	ANSI/ESDA/JEDEC JS-002	1	kV

Recommended Operating Conditions ^{Note 1}

Over operating temperature range

Parameters	Min	Max	Unit
Supply Voltage, $V_{CC} - V_{EE}$	3.3	16	V
Select Input Voltage ^{Note1}	0	V_{CC}	V
Input Transition Rise and Fall Rate		100	ns/V
Switch I/O Port Voltage ^{Note2}	V_{EE}	V_{CC}	V
Operating Temperature Range	-40	125	°C

Note 1: Select input must be held HIGH or LOW and it must not float.

Note 2: The voltage of V_{CC} , V_{EE} need be in the range of $V_{CC} - V_{EE}$

Electrical Characteristics

Dual Supply, $V_{CC} = 5V$, $V_{EE} = -8V$, $GND = 0V$, unless otherwise noted.

Symbol	Parameter	Conditions	V_{CC} / V_{EE} (V)	25°C	-40°C to 85°C	-40°C to 125°C	Limit	Unit
Power Supply								
I_{CC}	Quiescent Supply Current	$V_{IN} = 0V$ or V_{CC}		0.1	1	5	Max	μA
		$V_{IN} = 1.8V$ (应用场景)		70	80	85	Max	μA
		$V_{IN} = 3.3V$ (应用场景)		20	25	30	Max	μA
Digital Input (V_{IN})								
V_{IH}	Input Voltage High				1.5	1.5	Min	V
V_{IL}	Input Voltage Low				0.5	0.5	Max	V
I_{IN}	Control Input Leakage	$V_{IN} = 0V$ or V_{CC}		± 0.4	± 1	± 1	Max	μA
Analog Switch								
R_{ON}		$I_{OUT} = 10mA$, $V_{IS} = V_{CC}$ or V_{EE}		4			Typ	Ω
				4.5	6.5	7.5	Max	Ω
ΔR_{ON}	On Resistance Match between Channels	$I_{OUT} = 10mA$, $V_{IS} = V_{CC}$ or V_{EE}		0.25	0.3	0.35	Max	Ω
$R_{FLAT(ON)}$	On Resistance Flatness	$I_{OUT} = 10mA$, $V_{IS} = V_{CC}$ or V_{EE}		1.2	1.6	1.9	Max	Ω
$I_{CH(OFF)}$	Switch OFF Leakage Current on Channel	$V_{IS} = 4V$, $V_{OS} = -7V$; or $V_{IS} = -7V$, $V_{OS} = 4V$		± 0.1	± 1	± 1	Max	μA
$I_{COM(OFF)}$	Switch OFF Leakage Current on Common	$V_{IS} = 4V$, $V_{OS} = -7V$; or $V_{IS} = -7V$, $V_{OS} = 4V$		± 0.1	± 1	± 1	Max	μA
$I_{(ON)}$	Switch ON Leakage Current	$V_{IS} = V_{OS} = 4V$ or $-7V$		± 0.1	± 1	± 1	Max	μA
Dynamic Characteristics								
t_{ON}	Switch turn-on time	$V_{IS} = 2.5V$, Figure 4		160	180	200	Max	ns
t_{OFF}	Switch turn-off time	$V_{IS} = 2.5V$, Figure 4		120	130	140	Max	ns
	Break before make time	$V_{IS} = 2.5V$, Figure 5		55			Typ	ns
$t_{ON(EN)}$	Switch enable time	$V_{IS} = 2.5V$, Figure 6		120	130	140	Max	ns
$t_{OFF(EN)}$	Switch disable time	$V_{IS} = 2.5V$, Figure 6		170	190	210	Max	ns
	Charge Injection	$V_{GEN} = 0V$, Figure 7		12.5			Typ	pC
	OFF-Isolation	$f = 1MHz$, $R_L = 50\Omega$, $C_L = 5pF$		-64			Typ	dB
	Channel to Channel Crosstalk	$f = 1MHz$, $R_L = 50\Omega$, $C_L = 5pF$		-64			Typ	dB
BW	Bandwidth	$R_L = 50\Omega$, $C_L = 5pF$		150			Typ	MHz
THD+N	Total Harmonic Distortion + Noise	$R_L = 110\Omega$, $V_S = 5V_{pp}$, $f = 1kHz$		0.3			Typ	%
Capacitance								
C_{IN}	Switch Input Capacitance	$V_S = 0V$, $f = 1MHz$		20			Typ	pF
C_{COM}	Common Output Capacitance	$V_S = 0V$, $f = 1MHz$		30			Typ	pF

Dual Supply, $V_{CC} = 4.5$ to $5.5V$, $V_{EE} = -4.5$ to $5.5V$, $GND = 0V$, unless otherwise noted.

Symbol	Parameter	Conditions	V_{CC} / V_{EE} (V)	25°C	-40°C to 85°C	-40°C to 125°C	Limit	Unit
Power Supply								
I_{CC}	Quiescent Supply Current	$V_{IN} = 0V$ or V_{CC}	5.5/-5.5	0.1	1	1	Max	μA
Digital Input (V_{IN})								
V_{IH}	Input Voltage High				1.5	1.5	Min	V
V_{IL}	Input Voltage Low				0.5	0.5	Max	V
I_{IN}	Control Input Leakage	$V_{IN} = 0V$ or V_{CC}	5.5/-5.5	± 0.4	± 1	± 1	Max	μA
Analog Switch								
R_{ON}		$I_{OUT} = 10mA$, $V_{IS} = V_{CC}$ or V_{EE}	4.5/-4.5	4.5			Typ	Ω
				5	7	8	Max	Ω
ΔR_{ON}	On Resistance Match between Channels	$I_{OUT} = 10mA$, $V_{IS} = V_{CC}$ or V_{EE}	4.5/-4.5	0.25	0.3	0.35	Max	Ω
$R_{FLAT(ON)}$	On Resistance Flatness	$I_{OUT} = 10mA$, $V_{IS} = V_{CC}$ or V_{EE}	4.5/-4.5	1.5	1.7	2	Max	Ω
$I_{CH(OFF)}$	Switch OFF Leakage Current on Channel	$V_{IS} = 4.5V$, $V_{OS} = -4.5V$; or $V_{IS} = -4.5V$, $V_{OS} = 4.5V$	5.5/-5.5	± 0.1	± 1	± 1	Max	μA
$I_{COM(OFF)}$	Switch OFF Leakage Current on Common	$V_{IS} = 4.5V$, $V_{OS} = -4.5V$; or $V_{IS} = -4.5V$, $V_{OS} = 4.5V$	5.5/-5.5	± 0.1	± 1	± 1	Max	μA
$I_{(ON)}$	Switch ON Leakage Current	$V_{IS} = V_{OS} = 4.5V$ or $-4.5V$	5.5/-5.5	± 0.1	± 1	± 1	Max	μA
Dynamic Characteristics								
t_{ON}	Switch turn-on time	$V_{IS} = 2.5V$, Figure 4	4.5/-4.5	200	230	250	Max	ns
t_{OFF}	Switch turn-off time	$V_{IS} = 2.5V$, Figure 4	4.5/-4.5	130	140	150	Max	ns
	Break before make time	$V_{IS} = 2.5V$, Figure 5	4.5/-4.5	60			Typ	ns
$t_{ON(EN)}$	Switch enable time	$V_{IS} = 2.5V$, Figure 6	4.5/-4.5	130	150	160	Max	ns
$t_{OFF(EN)}$	Switch disable time	$V_{IS} = 2.5V$, Figure 6	4.5/-4.5	190	230	250	Max	ns
	Charge Injection	$V_{GEN} = 0V$, Figure 7	5/-5	12.5			Typ	pC
	OFF-Isolation	$f = 1MHz$, $R_L = 50\Omega$, $C_L = 5pF$	5/-5	-64			Typ	dB
	Channel to Channel Crosstalk	$f = 1MHz$, $R_L = 50\Omega$, $C_L = 5pF$	5/-5	-64			Typ	dB
BW	Bandwidth	$R_L = 50\Omega$, $C_L = 5pF$	5/-5	150			Typ	MHz
THD+N	Total Harmonic Distortion + Noise	$R_L = 110\Omega$, $V_S = 5V_{pp}$, $f = 1kHz$	5/-5	0.3			Typ	%
Capacitance								
C_{IN}	Switch Input Capacitance	$V_S = 0V$, $f = 1MHz$	5/-5	20			Typ	pF
C_{COM}	Common Output Capacitance	$V_S = 0V$, $f = 1MHz$	5/-5	30			Typ	pF

Single Supply, $V_{CC} = 10.8V$ to $13.2V$, $V_{EE} = 0V$, $GND = 0V$, unless otherwise noted.

Symbol	Parameter	Conditions	V_{CC}	25°C	-40°C to 85°C	-40°C to 125°C	Limit	Unit
Power Supply								
I_{CC}	Quiescent Supply Current	$V_{IN} = 0V$ or V_{CC}	13.2	0.1	1	1	Max	μA
		$V_{IN} = 5V$	13.2	300	350	350	Max	μA
Digital Input (V_{IN})								
V_{IH}	Input Voltage High				2.0	2.0	Min	V
V_{IL}	Input Voltage Low				0.6	0.6	Max	V
I_{IN}	Control Input Leakage	$V_{IN} = 0V$ or V_{CC}	13.2	± 0.4	± 1	± 1	Max	μA
Analog Switch								
R_{ON}		$I_{OUT} = 10mA$, $V_{IS} = V_{CC}$ or V_{EE}	10.8	4			Typ	Ω
				4.5	6.5	7.5	Max	Ω
ΔR_{ON}	On Resistance Match between Channels	$I_{OUT} = 10mA$, $V_{IS} = V_{CC}$ or V_{EE}	10.8	0.25	0.3	0.35	Max	Ω
$R_{FLAT(ON)}$	On Resistance Flatness	$I_{OUT} = 10mA$, $V_{IS} = V_{CC}$ or V_{EE}	10.8	1.4	1.6	1.9	Max	Ω
$I_{CH(OFF)}$	Switch OFF Leakage Current on Channel	$V_{IS} = 1V$, $V_{OS} = 10V$; or $V_{IS} = 10V$, $V_{OS} = 1V$	13.2	± 0.1	± 1	± 1	Max	μA
$I_{COM(OFF)}$	Switch OFF Leakage Current on Common	$V_{IS} = 1V$, $V_{OS} = 10V$; or $V_{IS} = 10V$, $V_{OS} = 1V$	13.2	± 0.1	± 1	± 1	Max	μA
$I_{(ON)}$	Switch ON Leakage Current	$V_{IS} = V_{OS} = 1V$ or $10V$	13.2	± 0.1	± 1	± 1	Max	μA
Dynamic Characteristics								
t_{ON}	Switch turn-on time	$V_{IS} = 8V$, Figure 4	10.8	150	180	200	Max	ns
t_{OFF}	Switch turn-off time	$V_{IS} = 8V$, Figure 4	10.8	100	120	130	Max	ns
	Break before make time	$V_{IS} = 8V$, Figure 5	10.8	55			Typ	ns
$t_{ON(EN)}$	Switch enable time	$V_{IS} = 8V$, Figure 6	10.8	90	100	110	Max	ns
$t_{OFF(EN)}$	Switch disable time	$V_{IS} = 8V$, Figure 6	10.8	150	180	200	Max	ns
	Charge Injection	$V_{GEN} = 6V$, Figure 7	12	12.5			Typ	pC
	OFF-Isolation	$f = 1MHz$, $R_L = 50\Omega$, $C_L = 5pF$	12	-64			Typ	dB
	Channel to Channel Crosstalk	$f = 1MHz$, $R_L = 50\Omega$, $C_L = 5pF$	12	-64			Typ	dB
BW	Bandwidth	$R_L = 50\Omega$, $C_L = 5pF$	12	150			Typ	MHz
THD+N	Total Harmonic Distortion + Noise	$R_L = 110\Omega$, $V_S = 5V_{pp}$, $f = 1kHz$	12	0.3			Typ	%
Capacitance								
C_{IN}	Switch Input Capacitance	$V_S = 6V$, $f = 1MHz$	12	20			Typ	pF
C_{COM}	Common Output Capacitance	$V_S = 6V$, $f = 1MHz$	12	30			Typ	pF

Single Supply, $V_{CC} = 4.5V$ to $5.5V$, $V_{EE} = 0V$, $GND = 0V$, unless otherwise noted.

Symbol	Parameter	Conditions	V_{CC}	25°C	-40°C to 85°C	-40°C to 125°C	Limit	Unit
Power Supply								
I_{CC}	Quiescent Supply Current	$V_{IN} = 0V$ or V_{CC}	5.5	0.1	1	1	Max	μA
Digital Input (V_{IN})								
V_{IH}	Input Voltage High				1.5	1.5	Min	V
V_{IL}	Input Voltage Low				0.5	0.5	Max	V
I_{IN}	Control Input Leakage	$V_{IN} = 0V$ or V_{CC}	5.5	± 0.4	± 1	± 1	Max	μA
Analog Switch								
R_{ON}		$I_{OUT} = 10mA$, $V_{IS} = V_{CC}$ or V_{EE}	4.5	8.5			Typ	Ω
				10	12.5	14	Max	Ω
ΔR_{ON}	On Resistance Match between Channels	$I_{OUT} = 10mA$, $V_{IS} = V_{CC}$ or V_{EE}	4.5	0.3	0.35	0.4	Max	Ω
$R_{FLAT(ON)}$	On Resistance Flatness	$I_{OUT} = 10mA$, $V_{IS} = V_{CC}$ or V_{EE}	4.5	3.1	3.3	3.5	Max	Ω
$I_{CH(OFF)}$	Switch OFF Leakage Current on Channel	$V_{IS} = 1V$, $V_{OS} = 4.5V$; or $V_{IS} = 4.5V$, $V_{OS} = 1V$	5.5	± 0.1	± 1	± 1	Max	μA
$I_{COM(OFF)}$	Switch OFF Leakage Current on Common	$V_{IS} = 1V$, $V_{OS} = 4.5V$; or $V_{IS} = 4.5V$, $V_{OS} = 1V$	5.5	± 0.1	± 1	± 1	Max	μA
$I_{(ON)}$	Switch ON Leakage Current	$V_{IS} = V_{OS} = 1V$ or $4.5V$	5.5	± 0.1	± 1	± 1	Max	μA
Dynamic Characteristics								
t_{ON}	Switch turn-on time	$V_{IS} = 2.5V$, Figure 4		300	320	350	Max	ns
t_{OFF}	Switch turn-off time	$V_{IS} = 2.5V$, Figure 4		130	150	160	Max	ns
	Break before make time	$V_{IS} = 2.5V$, Figure 5		100			Typ	ns
$t_{ON(EN)}$	Switch enable time	$V_{IS} = 2.5V$, Figure 6		180	200	210	Max	ns
$t_{OFF(EN)}$	Switch disable time	$V_{IS} = 2.5V$, Figure 6		230	260	280	Max	ns
	Charge Injection	$V_{GEN} = 2.5V$, Figure 7	5	5			Typ	pC
	OFF-Isolation	$f = 1MHz$, $R_L = 50\Omega$, $C_L = 5pF$	5	-64			Typ	dB
	Channel to Channel Crosstalk	$f = 1MHz$, $R_L = 50\Omega$, $C_L = 5pF$	5	-64			Typ	dB
BW	Bandwidth	$R_L = 50\Omega$, $C_L = 5pF$	5	100			Typ	MHz
THD+N	Total Harmonic Distortion + Noise	$R_L = 110\Omega$, $V_S = 3.5V_{pp}$, $f = 1kHz$	5	0.3			Typ	%
Capacitance								
C_{IN}	Switch Input Capacitance	$V_S = 2.5V$, $f = 1MHz$	5	20			Typ	pF
C_{COM}	Common Output Capacitance	$V_S = 2.5V$, $f = 1MHz$	5	30			Typ	pF

Single Supply, $V_{CC} = 3.3V$, $V_{EE} = 0V$, $GND = 0V$, unless otherwise noted.

Symbol	Parameter	Conditions	V_{CC}	25°C	-40°C to 85°C	-40°C to 125°C	Limit	Unit
Power Supply								
I_{CC}	Quiescent Supply Current	$V_{IN} = 0V$ or V_{CC}		0.1	1	1	Max	μA
Digital Input (V_{IN})								
V_{IH}	Input Voltage High				1.4	1.4	Min	V
V_{IL}	Input Voltage Low				0.4	0.4	Max	V
I_{IN}	Control Input Leakage	$V_{IN} = 0V$ or V_{CC}		± 0.4	± 1	± 1	Max	μA
Analog Switch								
R_{ON}		$I_{OUT} = 10mA$, $V_{IS} = V_{CC}$ or V_{EE}		13.5	15	16.5	Typ	Ω
ΔR_{ON}	On Resistance Match between Channels	$I_{OUT} = 10mA$, $V_{IS} = V_{CC}$ or V_{EE}		0.25	0.28	0.3	Typ	Ω
$R_{FLAT(ON)}$	On Resistance Flatness	$I_{OUT} = 10mA$, $V_{IS} = V_{CC}$ or V_{EE}		5.5	7	7.5	Typ	Ω
$I_{CH(OFF)}$	Switch OFF Leakage Current on Channel	$V_{IS} = 0.6V$, $V_{OS} = 3V$; or $V_{IS} = 3V$, $V_{OS} = 0.6V$		± 0.1	± 1	± 1	Max	μA
$I_{COM(OFF)}$	Switch OFF Leakage Current on Common	$V_{IS} = 0.6V$, $V_{OS} = 3V$; or $V_{IS} = 3V$, $V_{OS} = 0.6V$		± 0.1	± 1	± 1	Max	μA
$I_{(ON)}$	Switch ON Leakage Current	$V_{IS} = V_{OS} = 0.6V$ or $3V$		± 0.1	± 1	± 1	Max	μA
Dynamic Characteristics								
t_{ON}	Switch turn-on time	$V_{IS} = 1.5V$, Figure 4		480	500	520	Max	ns
t_{OFF}	Switch turn-off time	$V_{IS} = 1.5V$, Figure 4		190	200	210	Max	ns
	Break before make time	$V_{IS} = 1.5V$, Figure 5		200			Typ	ns
$t_{ON(EN)}$	Switch enable time	$V_{IS} = 1.5V$, Figure 6		300	330	350	Max	ns
$t_{OFF(EN)}$	Switch disable time	$V_{IS} = 1.5V$, Figure 6		410	470	500	Max	ns
	Charge Injection	$V_{GEN} = 1.5V$, Figure 7		10			Typ	pC
	OFF-Isolation	$f = 1MHz$, $R_L = 50\Omega$, $C_L = 5pF$		-64			Typ	dB
	Channel to Channel Crosstalk	$f = 1MHz$, $R_L = 50\Omega$, $C_L = 5pF$		-64			Typ	dB
BW	Bandwidth	$R_L = 50\Omega$, $C_L = 5pF$		100			Typ	MHz
THD+N	Total Harmonic Distortion + Noise	$R_L = 110\Omega$, $V_S = 2V_{pp}$, $f = 1kHz$		0.6			Typ	%
Capacitance								
C_{IN}	Switch Input Capacitance	$V_S = 1.5V$, $f = 1MHz$	3.3	20			Typ	pF
C_{COM}	Common Output Capacitance	$V_S = 1.5V$, $f = 1MHz$	3.3	30			Typ	pF

Single Supply, $V_{CC} = 16V$, $V_{EE} = 0V$, $GND = 0V$, unless otherwise noted.

Symbol	Parameter	Conditions	V_{CC}	25°C	-40°C to 85°C	-40°C to 125°C	Limit	Unit
Power Supply								
I_{CC}	Quiescent Supply Current	$V_{IN} = 0V$ or V_{CC}		0.1	1	1	Max	μA
Digital Input (V_{IN})								
V_{IH}	Input Voltage High					2.4	Min	V
V_{IL}	Input Voltage Low					0.6	Max	V
I_{IN}	Control Input Leakage	$V_{IN} = 0V$ or V_{CC}		± 0.4	± 1	± 1	Typ	μA
Analog Switch								
R_{ON}		$I_{OUT} = 10mA$, $V_{IS} = V_{CC}$ or V_{EE}		3.5	5	6	Typ	Ω
ΔR_{ON}	On Resistance Match between Channels	$I_{OUT} = 10mA$, $V_{IS} = V_{CC}$ or V_{EE}		0.25	0.28	0.3	Typ	Ω
$R_{FLAT(ON)}$	On Resistance Flatness	$I_{OUT} = 10mA$, $V_{IS} = V_{CC}$ or V_{EE}		1.2	1.5	1.8	Typ	Ω
$I_{CH(OFF)}$	Switch OFF Leakage Current on Channel	$V_{IS} = 1V$, $V_{OS} = 14V$; or $V_{IS} = 14V$, $V_{OS} = 1V$		± 0.1	± 1	± 1	Typ	μA
$I_{COM(OFF)}$	Switch OFF Leakage Current on Common	$V_{IS} = 1V$, $V_{OS} = 14V$; or $V_{IS} = 14V$, $V_{OS} = 1V$		± 0.1	± 1	± 1	Typ	μA
$I_{(ON)}$	Switch ON Leakage Current	$V_{IS} = V_{OS} = 1V$ or $14V$		± 0.1	± 1	± 1	Typ	μA
Dynamic Characteristics								
t_{ON}	Switch turn-on time	$V_{IS} = 8V$, Figure 4		140	170	190	Typ	ns
t_{OFF}	Switch turn-off time	$V_{IS} = 8V$, Figure 4		90	100	110	Typ	ns
	Break before make time	$V_{IS} = 8V$, Figure 5		55			Typ	ns
$t_{ON(EN)}$	Switch enable time	$V_{IS} = 8V$, Figure 6		80	90	100	Typ	ns
$t_{OFF(EN)}$	Switch disable time	$V_{IS} = 8V$, Figure 6		140	160	180	Typ	ns
	Charge Injection	$V_{GEN} = 8V$, Figure 7		10			Typ	pC
	OFF-Isolation	$f = 1MHz$, $R_L = 50\Omega$, $C_L = 5pF$		-64			Typ	dB
	Channel to Channel Crosstalk	$f = 1MHz$, $R_L = 50\Omega$, $C_L = 5pF$		-64			Typ	dB
BW	Bandwidth	$R_L = 50\Omega$, $C_L = 5pF$		150			Typ	MHz
THD+N	Total Harmonic Distortion + Noise	$R_L = 110\Omega$, $V_S = 7V_{pp}$, $f = 1kHz$		0.1			Typ	%
Capacitance								
C_{IN}	Switch Input Capacitance	$V_S = 8V$, $f = 1MHz$		20			Typ	pF
C_{COM}	Common Output Capacitance	$V_S = 8V$, $f = 1MHz$		30			Typ	pF

Typical Performance Characteristics

V_{CC} = 5V, unless otherwise specified.

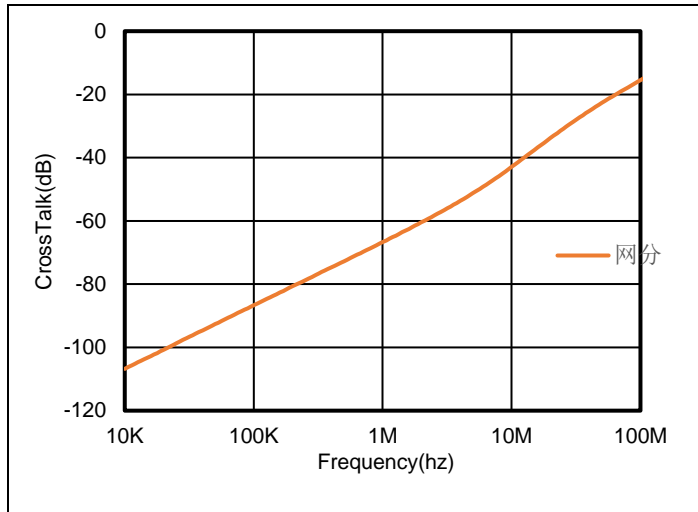

Figure 1. Off-Isolation, V_{CC} = 5V, V_{EE} = -8V

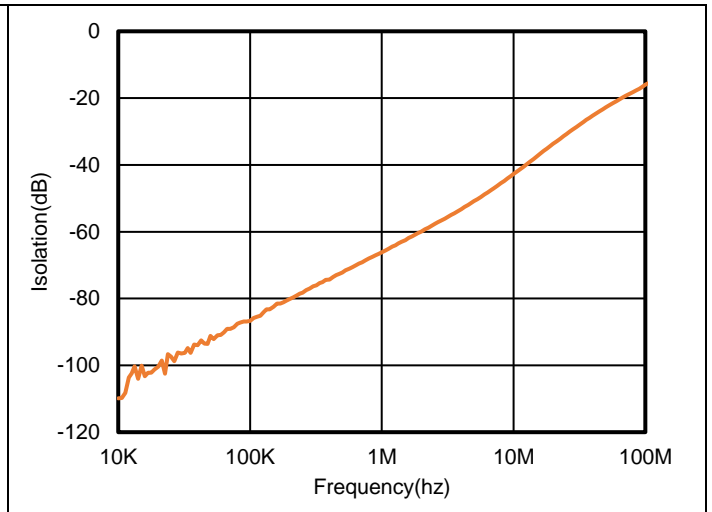

Figure 2. Crosstalk, V_{CC} = 5V, V_{EE} = -8V

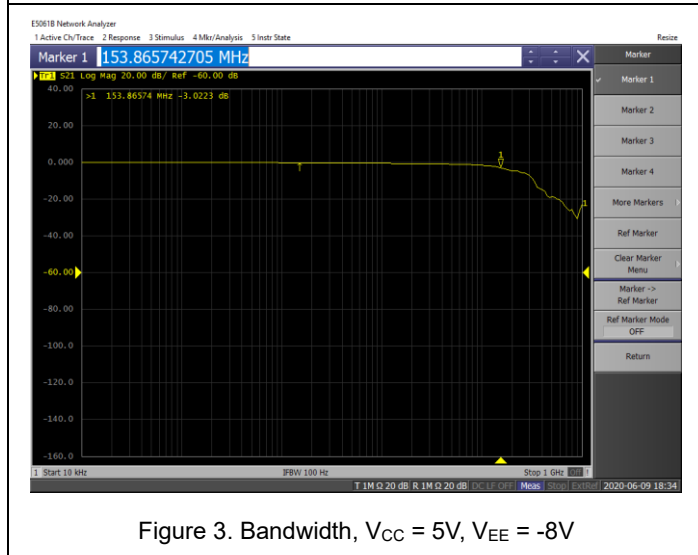

Figure 3. Bandwidth, V_{CC} = 5V, V_{EE} = -8V

Test Circuit and Waveforms

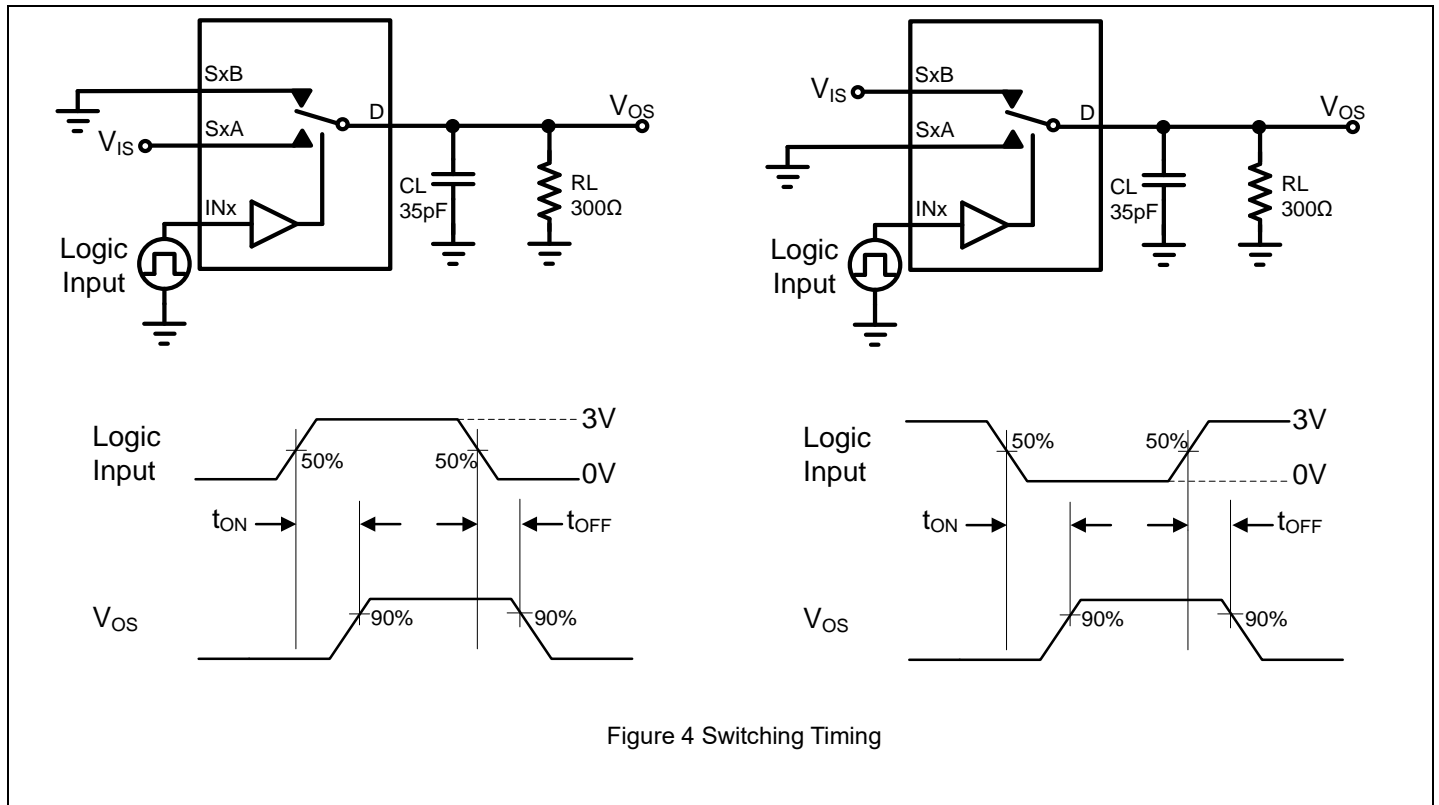

Figure 4 Switching Timing

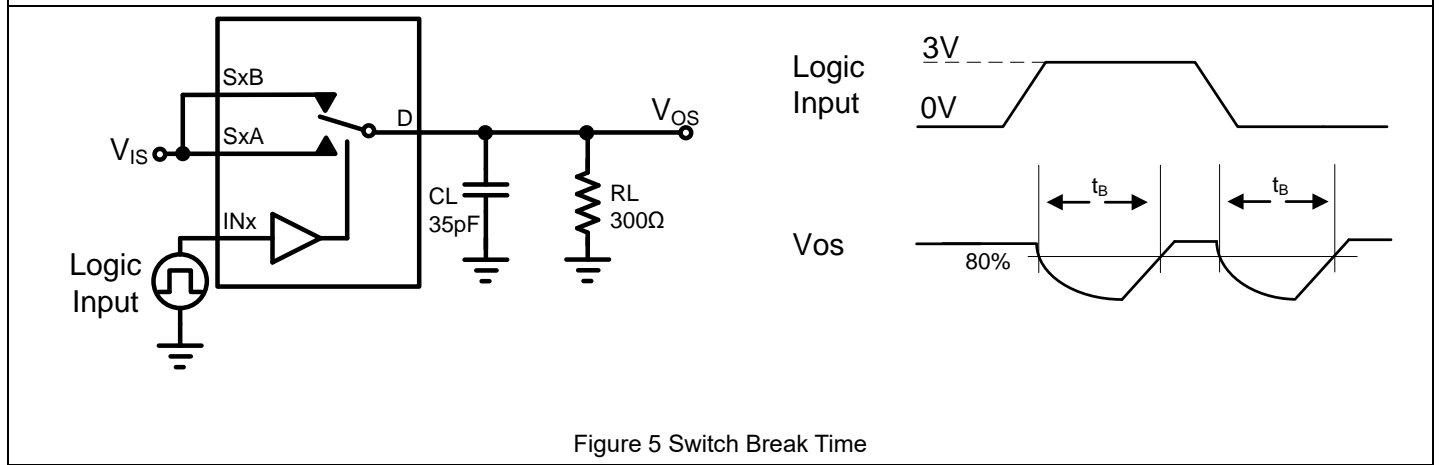

Figure 5 Switch Break Time

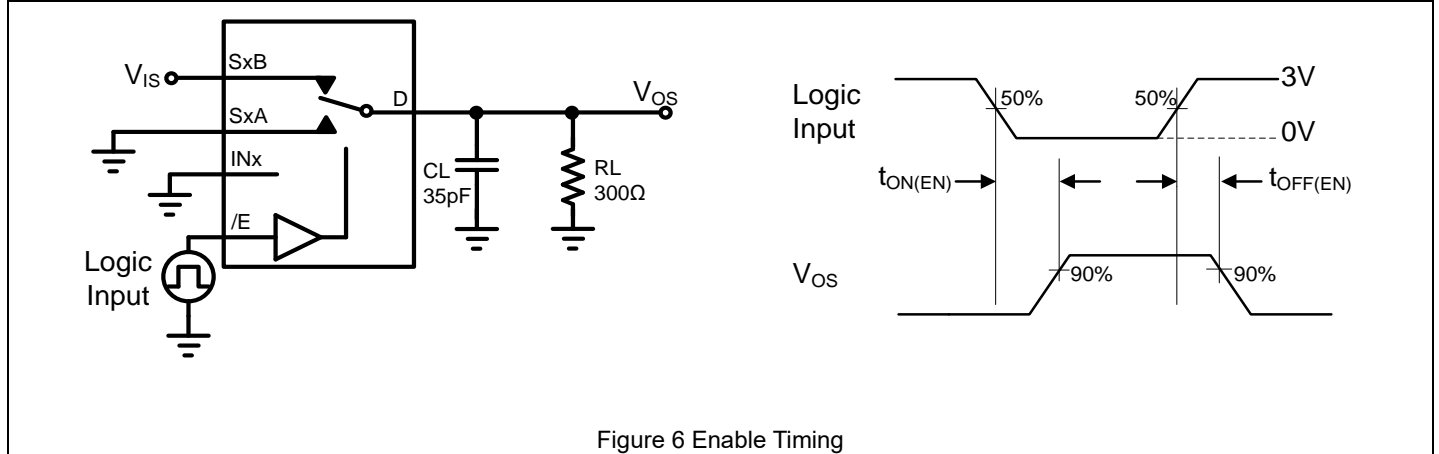
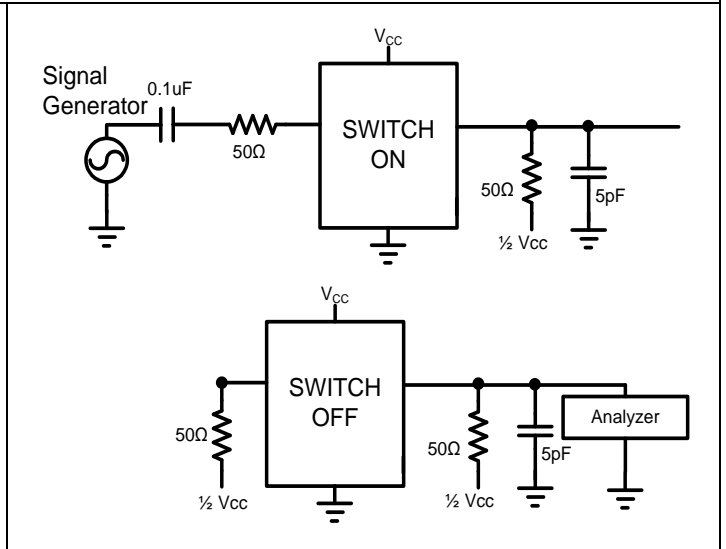
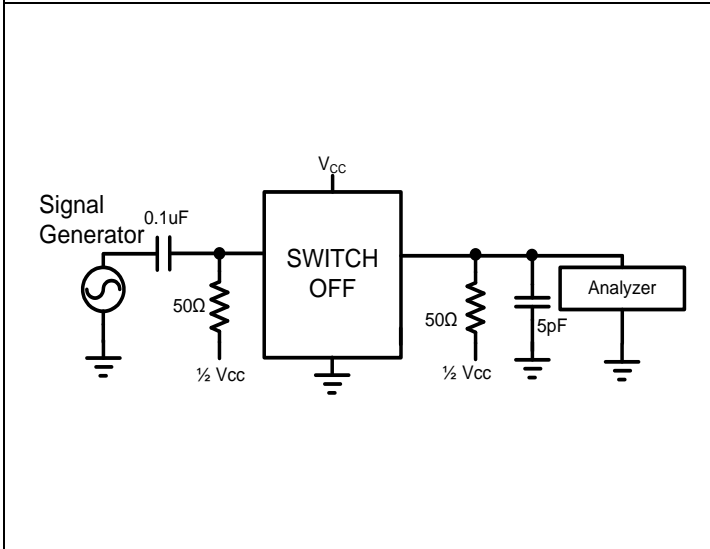
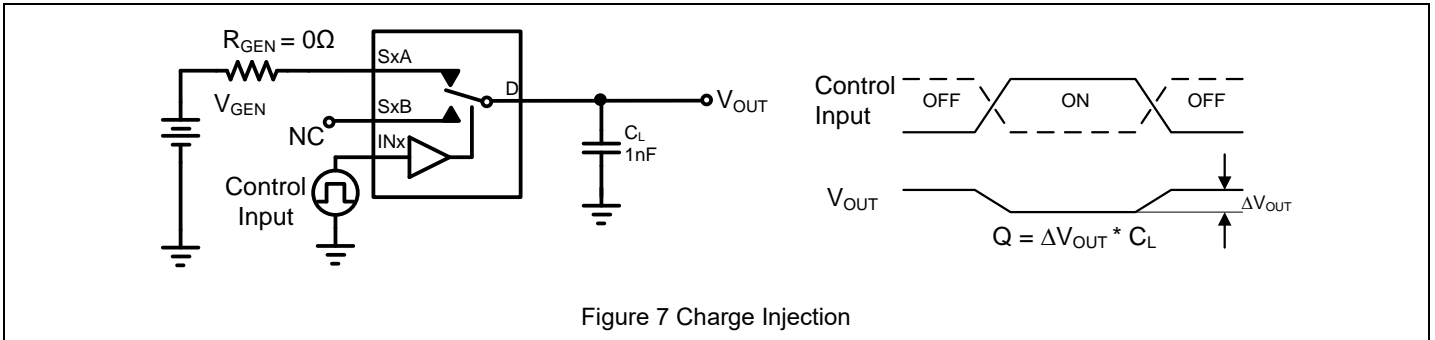

Figure 6 Enable Timing



Application Information

A 0.1- μ F bypass capacitor on VCC and GND is recommended to prevent power disturbance, another 0.1- μ F bypass capacitor on VEE and GND is also recommended if the VSS is not connected to GND.

Tape and Reel Information

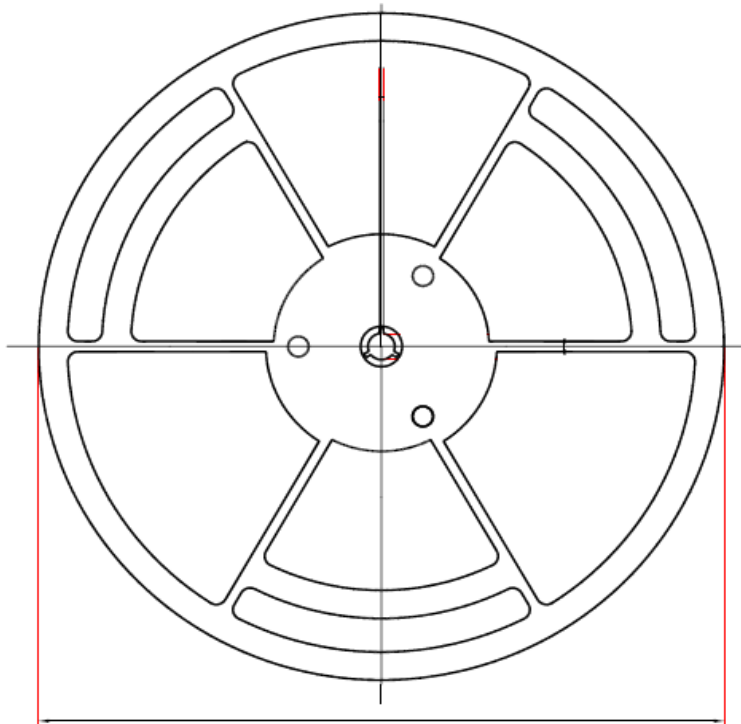

D1: Reel Diameter

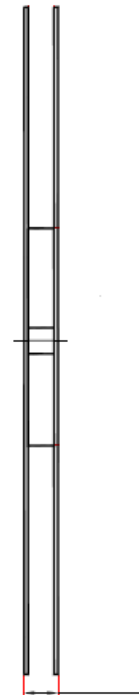

W1: Reel Width

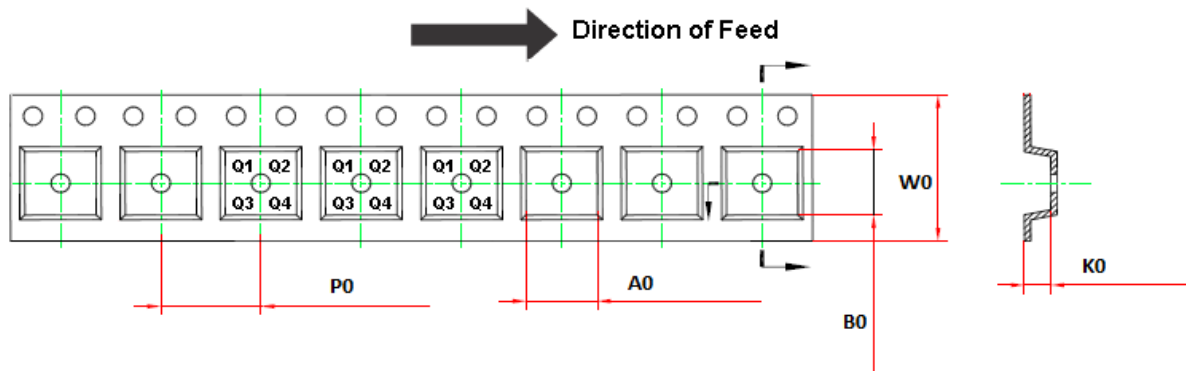

Order Number	Package	D1 (mm)	W1 (mm)	A0 (mm)	B0 (mm)	K0 (mm)	P0 (mm)	W0 (mm)	Pin1 Quadrant
TPW4425-QFKR	20Pin QFN	330	17.6	4.3	4.3	1.1	8	12	Q2

Package Outline Dimensions

TSSOP20

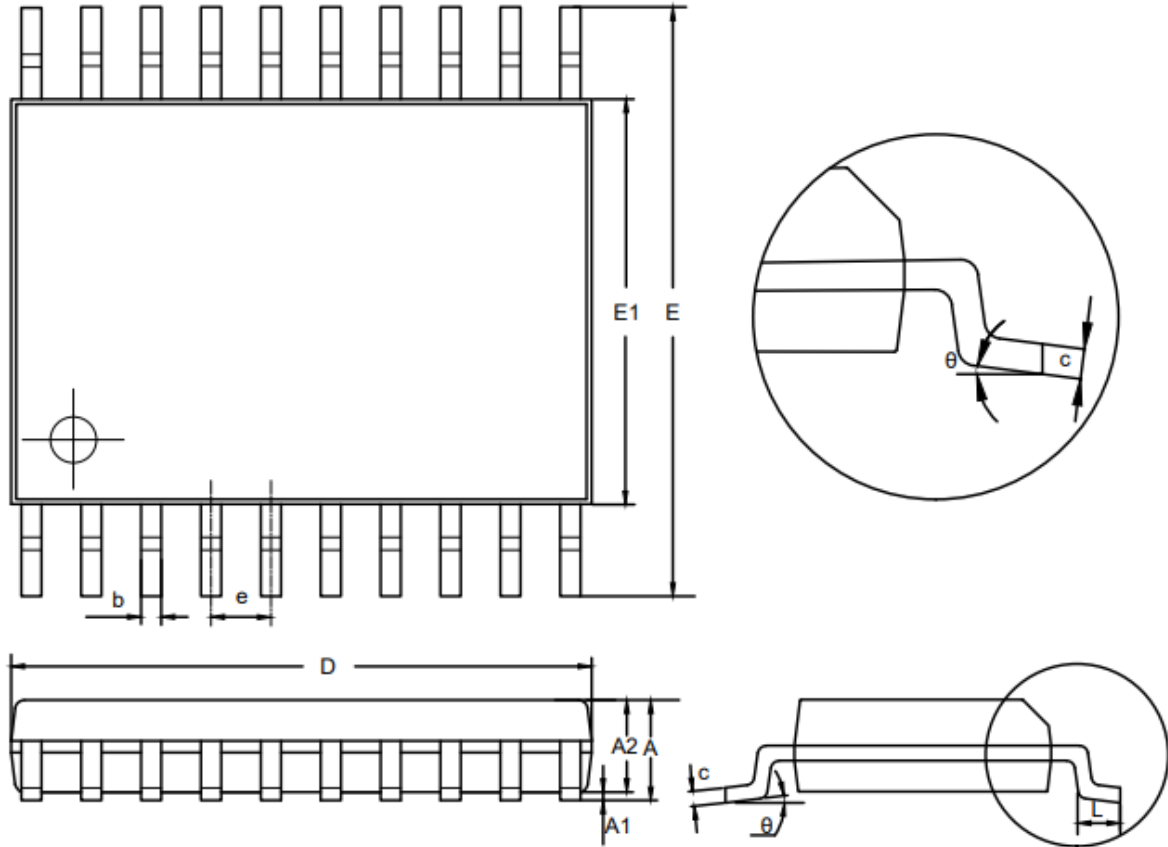

Symbol	Dimensions In Millimeters		Dimensions In Inches	
	MIN	MAX	MIN	MAX
A	0.900	1.200	0.035	0.047
A1	0.050	0.150	0.002	0.006
A2	0.800	1.050	0.031	0.041
b	0.190	0.300	0.007	0.012
c	0.090	0.200	0.004	0.008
D	6.400	6.600	0.252	0.260
E	6.200	6.600	0.244	0.260
E1	4.300	4.500	0.169	0.177
e	0.650 BSC		0.026 BSC	
L	0.450	0.750	0.018	0.030
theta	0	8°	0	8°

NOTES

1. Do not include mold flash or protrusion.
2. This drawing is subject to change without notice.

Package Outline Dimensions

QFN-20

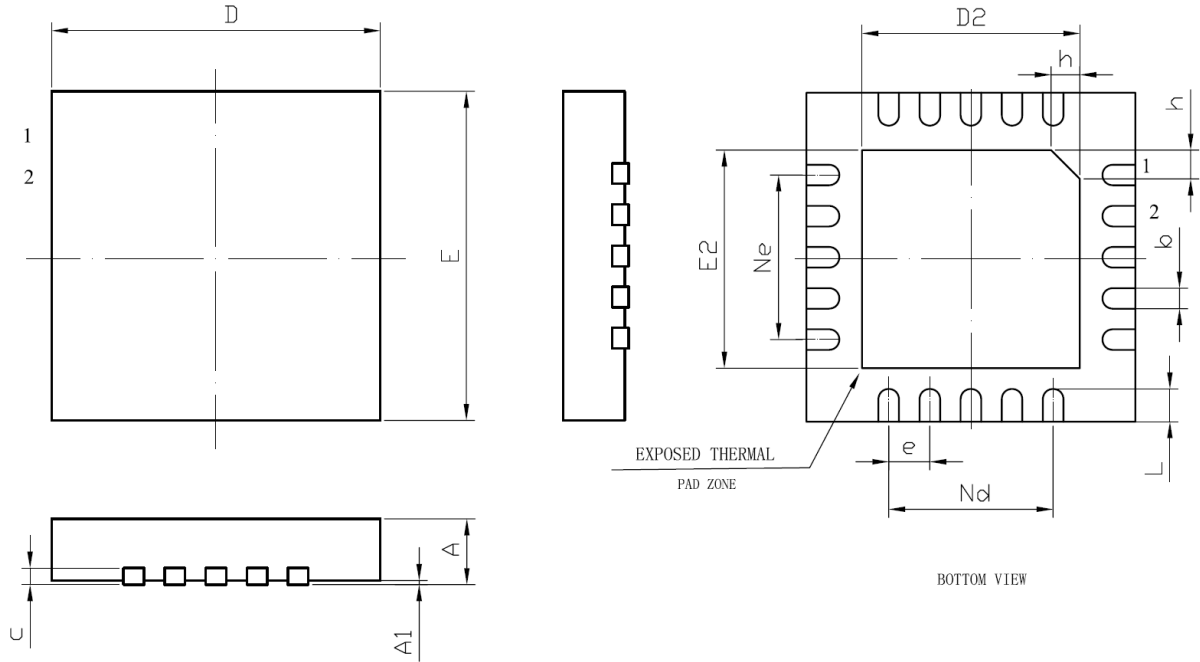

SYMBOL	MILLIMETER		
	MIN	NOM	MAX
A	0.70	0.75	0.80
A1	—	0.02	0.05
b	0.18	0.25	0.30
c	0.18	0.20	0.25
D	3.90	4.00	4.10
D2	2.55	2.65	2.75
e	0.50BSC		
Ne	2.00BSC		
Nd	2.00BSC		
E	3.90	4.00	4.10
E2	2.55	2.65	2.75
L	0.35	0.40	0.45
h	0.30	0.35	0.40

IMPORTANT NOTICE AND DISCLAIMER

Copyright© 3PEAK 2012-2023. All rights reserved.

Trademarks. Any of the 思瑞浦 or 3PEAK trade names, trademarks, graphic marks, and domain names contained in this document /material are the property of 3PEAK. You may NOT reproduce, modify, publish, transmit or distribute any Trademark without the prior written consent of 3PEAK.

Performance Information. Performance tests or performance range contained in this document/material are either results of design simulation or actual tests conducted under designated testing environment. Any variation in testing environment or simulation environment, including but not limited to testing method, testing process or testing temperature, may affect actual performance of the product.

Disclaimer. 3PEAK provides technical and reliability data (including data sheets), design resources (including reference designs), application or other design recommendations, networking tools, security information and other resources "As Is". 3PEAK makes no warranty as to the absence of defects, and makes no warranties of any kind, express or implied, including without limitation, implied warranties as to merchantability, fitness for a particular purpose or non-infringement of any third-party's intellectual property rights. Unless otherwise specified in writing, products supplied by 3PEAK are not designed to be used in any life-threatening scenarios, including critical medical applications, automotive safety-critical systems, aviation, aerospace, or any situations where failure could result in bodily harm, loss of life, or significant property damage. 3PEAK disclaims all liability for any such unauthorized use.

Looking for pricing, stock, or lifecycle information?

Click below to explore more details on WIN SOURCE:

 [View TPS16850VMAR](#) on WIN SOURCE

 [Texas Instruments](#) Information

Optimize Your Supply Chain with WIN SOURCE Solutions

-  Global Sourcing Solution
-  Obsolete Management
-  Cost Control Management
-  Shortage Management
-  Alternative Solution
-  Excess Inventory Management