



**THE DATASHEET OF
USL00-30L-A**



TAS6511-Q1 50W, 2MHz Digital Input 1-Channel Automotive Heatsink-Free Class-D Audio Amplifier with Current Sense and Real-time Load Diagnostics

1 Features

- AEC-Q100 qualified for automotive applications
 - Temperature grade 1: -40°C to $+125^{\circ}\text{C}$, T_A
- General operation
 - 4.5V to 19V supply voltage, 40V load dump
 - Support for 1.8V and 3.3V I/O's
 - I²C control with 8 address options
 - $<0.5\text{W}$ idle power loss at 14.4V, $<5\mu\text{A}$ max PVDD shutdown loss
- Output current sensing via I²S or TDM
 - No need for external circuitry
- Real-time load diagnostics
 - Monitor output conditions while playing audio
 - Open load, Shorted load, Short-to-power, Short-to-ground detection
- Integrated DSP processing
 - Thermal monitoring and foldback
 - PVDD monitoring and foldback
 - Clip detection
 - Low Latency Path, $>70\%$ reduced signal delay at 48kHz
- DC and AC Standby load diagnostics
- Audio inputs
 - I²S and TDM support up to TDM16
 - Input sample rates: 16, 32, 44.1, 48, 96, 192kHz
- Audio outputs
 - 384kHz to 2MHz configurable output switching frequency
 - Up to 7A channel output current
 - 30W (14.4V, 4 Ω , 10% THD+N)
 - 50W (14.4V, 2 Ω , 10% THD+N)
- Audio Performance
 - THD+N $<0.02\%$ (4 Ω , 1W, 1kHz)
 - 108dB SNR
 - Output noise: $41\mu\text{V}_{\text{RMS}}$ at 14.4V, A-weighting
- Protection
 - Output short protection
 - Speaker Guard™ Pro power limiter
 - Configurable overtemperature warning and shutdown
 - I²C temperature and supply voltage readout
 - DC offset, undervoltage and overvoltage
- Easily meet CISPR25-L5 EMC specification
 - Advanced spread-spectrum

- [Automotive head unit](#)
- [Telematics control unit](#)
- [Automotive cluster display](#)

3 Description

The TAS6511-Q1 is a mono-channel, digital-input, Class-D audio amplifier that supports 2MHz switching frequency enabling a cost and size-optimized single-channel audio amplifier design. The device operates from 4.5V to 19V and delivers up to 30W (14.4V, 4 Ω , 10% THD+N) and up to 50W (14.4V, 2 Ω , 10% THD+N). The device integrates DC and AC load diagnostics to determine the status of the connected load before enabling the output stage. Additionally, the device can monitor the output load condition while in PLAY mode with or without audio using real-time load diagnostics which operates independently from the host and audio input.

TAS6511-Q1 can monitor the output current, PVDD voltage, and temperature of the device and can report this data through TDM or I²S. The integrated DSP of the TAS6511-Q1 enables advanced protection features such as PVDD foldback, thermal foldback, and Speaker Guard™ Pro power limiter. The DSP also enables an additional low-latency signal path, providing up to 70% faster signal processing at 48kHz for time-sensitive Active Noise Cancellation (ANC) and Road Noise Cancellation (RNC) applications.

The device is available in a small pad-down TSSOP and QFN with wettable flanks packages, enabling a heatsink-free audio amplifier design.

Package Information

PART NUMBER	PACKAGE ⁽¹⁾	PACKAGE SIZE ⁽²⁾
TAS6511-Q1	PWP (HTSSOP, 28)	6.4mm × 9.7mm
	RGE (VQFN, 24)	4mm × 4mm

(1) For more information, see [Section 7](#).

(2) The package size (length × width) is a nominal value and includes pins, where applicable.

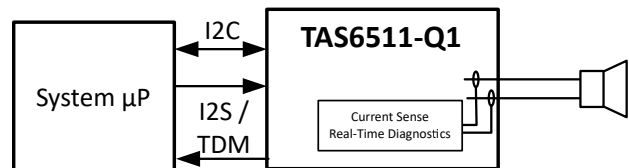

Simplified Diagram

2 Applications

- [Acoustic vehicle alerting system \(AVAS\)](#)
- [Emergency call \(eCall\)](#)



Table of Contents

1 Features	1	5.2 Support Resources.....	4
2 Applications	1	5.3 Trademarks.....	4
3 Description	1	5.4 Electrostatic Discharge Caution.....	4
4 Related Products	3	5.5 Glossary.....	4
5 Device and Documentation Support	4	6 Revision History	4
5.1 Receiving Notification of Documentation Updates.....	4	7 Mechanical, Packaging, and Orderable Information	5

4 Related Products

Table 4-1. Related Class-D Audio Amplifiers

DEVICE	CHANNEL CURRENT LIMIT (TYPICAL)	OUTPUT POWER / 10% THD+N
		4Ω / 14.4V
TAS6501-Q1	3.7A	15W
TAS6511-Q1	7.3A	30W

5 Device and Documentation Support

TI offers an extensive line of development tools. Tools and software to evaluate the performance of the device, generate code, and develop designs are listed below.

5.1 Receiving Notification of Documentation Updates

To receive notification of documentation updates, navigate to the device product folder on ti.com. Click on *Notifications* to register and receive a weekly digest of any product information that has changed. For change details, review the revision history included in any revised document.

5.2 Support Resources

TI E2E™ [support forums](#) are an engineer's go-to source for fast, verified answers and design help — straight from the experts. Search existing answers or ask your own question to get the quick design help you need.

Linked content is provided "AS IS" by the respective contributors. They do not constitute TI specifications and do not necessarily reflect TI's views; see TI's [Terms of Use](#).

5.3 Trademarks

TI E2E™ is a trademark of Texas Instruments.

All trademarks are the property of their respective owners.

5.4 Electrostatic Discharge Caution



This integrated circuit can be damaged by ESD. Texas Instruments recommends that all integrated circuits be handled with appropriate precautions. Failure to observe proper handling and installation procedures can cause damage.

ESD damage can range from subtle performance degradation to complete device failure. Precision integrated circuits may be more susceptible to damage because very small parametric changes could cause the device not to meet its published specifications.

5.5 Glossary

[TI Glossary](#) This glossary lists and explains terms, acronyms, and definitions.

6 Revision History

NOTE: Page numbers for previous revisions may differ from page numbers in the current version.

Changes from Revision B (April 2025) to Revision C (January 2026)	Page
• Added RGE (VQFN) package information throughout the document.....	1
• Added <i>Related Products</i> section.....	3

Changes from Revision A (December 2024) to Revision B (April 2025)	Page
• Updated 14.4V, 4Ω, 10% THD+N output power to 30W.....	1
• Added Mechanical, Packaging, and Orderable Information section.....	5

Changes from Revision * (December 2023) to Revision A (December 2024)	Page
• Updated device status to production data.....	1

7 Mechanical, Packaging, and Orderable Information

The following pages include mechanical, packaging, and orderable information. This information is the most current data available for the designated devices. This data is subject to change without notice and revision of this document. For browser-based versions of this data sheet, refer to the left-hand navigation.

PACKAGING INFORMATION

Orderable part number	Status (1)	Material type (2)	Package Pins	Package qty Carrier	RoHS (3)	Lead finish/ Ball material (4)	MSL rating/ Peak reflow (5)	Op temp (°C)	Part marking (6)
TAS6511QPWPRQ1	Active	Production	HTSSOP (PWP) 28	2000 LARGE T&R	Yes	NIPDAU	Level-3-260C-168 HR	-40 to 125	TAS6511
TAS6511QPWPRQ1.A	Active	Production	HTSSOP (PWP) 28	2000 LARGE T&R	Yes	NIPDAU	Level-3-260C-168 HR	-40 to 125	TAS6511
TAS6511QRGERQ1	Active	Preproduction	VQFN (RGE) 24	3000 LARGE T&R	Yes	NIPDAU	Level-2-260C-1 YEAR	-40 to 125	TAS6511

(1) **Status:** For more details on status, see our [product life cycle](#).

(2) **Material type:** When designated, preproduction parts are prototypes/experimental devices, and are not yet approved or released for full production. Testing and final process, including without limitation quality assurance, reliability performance testing, and/or process qualification, may not yet be complete, and this item is subject to further changes or possible discontinuation. If available for ordering, purchases will be subject to an additional waiver at checkout, and are intended for early internal evaluation purposes only. These items are sold without warranties of any kind.

(3) **RoHS values:** Yes, No, RoHS Exempt. See the [TI RoHS Statement](#) for additional information and value definition.

(4) **Lead finish/Ball material:** Parts may have multiple material finish options. Finish options are separated by a vertical ruled line. Lead finish/Ball material values may wrap to two lines if the finish value exceeds the maximum column width.

(5) **MSL rating/Peak reflow:** The moisture sensitivity level ratings and peak solder (reflow) temperatures. In the event that a part has multiple moisture sensitivity ratings, only the lowest level per JEDEC standards is shown. Refer to the shipping label for the actual reflow temperature that will be used to mount the part to the printed circuit board.

(6) **Part marking:** There may be an additional marking, which relates to the logo, the lot trace code information, or the environmental category of the part.

Multiple part markings will be inside parentheses. Only one part marking contained in parentheses and separated by a "-" will appear on a part. If a line is indented then it is a continuation of the previous line and the two combined represent the entire part marking for that device.

Important Information and Disclaimer: The information provided on this page represents TI's knowledge and belief as of the date that it is provided. TI bases its knowledge and belief on information provided by third parties, and makes no representation or warranty as to the accuracy of such information. Efforts are underway to better integrate information from third parties. TI has taken and continues to take reasonable steps to provide representative and accurate information but may not have conducted destructive testing or chemical analysis on incoming materials and chemicals. TI and TI suppliers consider certain information to be proprietary, and thus CAS numbers and other limited information may not be available for release.

In no event shall TI's liability arising out of such information exceed the total purchase price of the TI part(s) at issue in this document sold by TI to Customer on an annual basis.

TAPE AND REEL INFORMATION

QUADRANT ASSIGNMENTS FOR PIN 1 ORIENTATION IN TAPE

*All dimensions are nominal

Device	Package Type	Package Drawing	Pins	SPQ	Reel Diameter (mm)	Reel Width W1 (mm)	A0 (mm)	B0 (mm)	K0 (mm)	P1 (mm)	W (mm)	Pin1 Quadrant
TAS6511QPWRQ1	HTSSOP	PWP	28	2000	330.0	16.4	6.75	10.1	1.8	12.0	16.0	Q1
TAS6511QRGERQ1	VQFN	RGE	24	3000	330.0	12.4	4.25	4.25	1.15	8.0	12.0	Q2

TAPE AND REEL BOX DIMENSIONS



*All dimensions are nominal

Device	Package Type	Package Drawing	Pins	SPQ	Length (mm)	Width (mm)	Height (mm)
TAS6511QPWPRQ1	HTSSOP	PWP	28	2000	353.0	353.0	32.0
TAS6511QRGERQ1	VQFN	RGE	24	3000	367.0	367.0	35.0

GENERIC PACKAGE VIEW

PWP 28

PowerPAD™ TSSOP - 1.2 mm max height

4.4 x 9.7, 0.65 mm pitch

SMALL OUTLINE PACKAGE

This image is a representation of the package family, actual package may vary.
Refer to the product data sheet for package details.

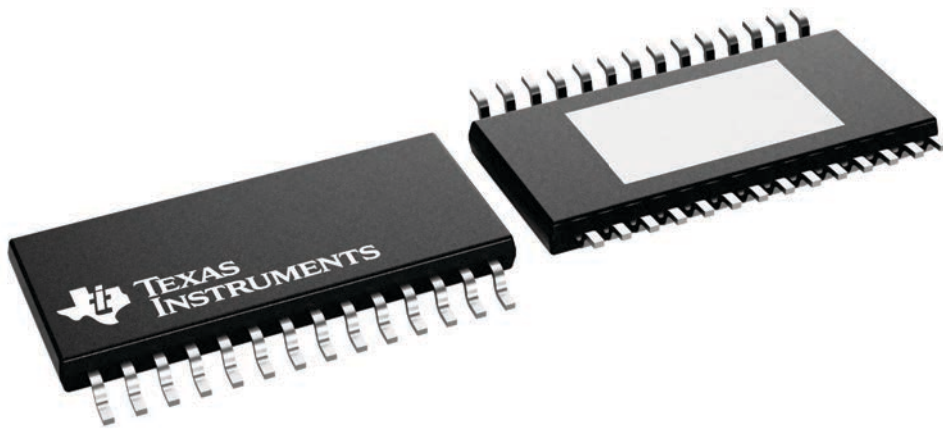

4224765/B

EXAMPLE BOARD LAYOUT

PWP0028M

PowerPAD™ TSSOP - 1.2 mm max height

SMALL OUTLINE PACKAGE

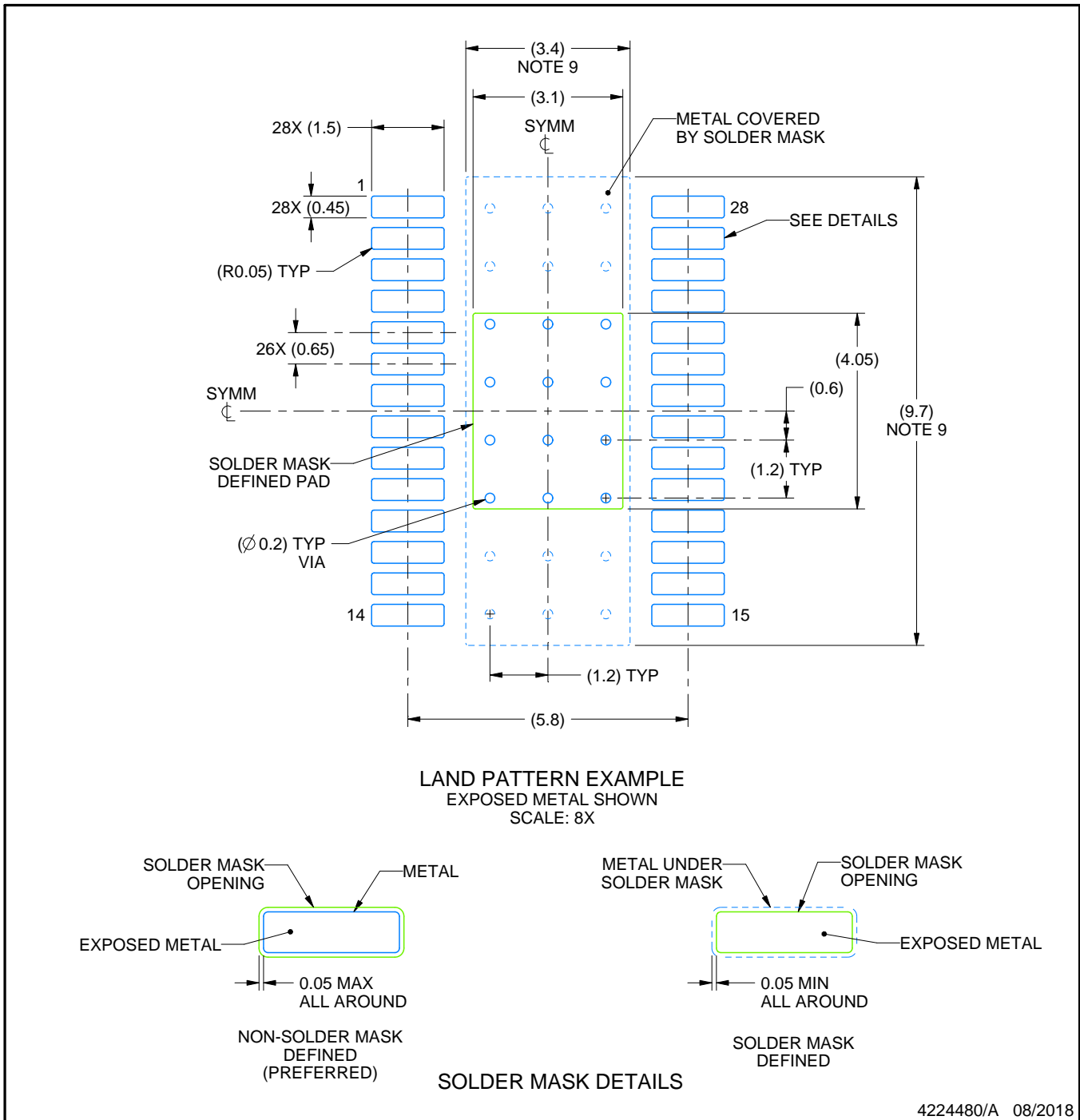

NOTES: (continued)

6. Publication IPC-7351 may have alternate designs.
7. Solder mask tolerances between and around signal pads can vary based on board fabrication site.
8. This package is designed to be soldered to a thermal pad on the board. For more information, see Texas Instruments literature numbers SLMA002 (www.ti.com/lit/slma002) and SLMA004 (www.ti.com/lit/slma004).
9. Size of metal pad may vary due to creepage requirement.
10. Vias are optional depending on application, refer to device data sheet. It is recommended that vias under paste be filled, plugged or tented.

EXAMPLE STENCIL DESIGN

PWP0028M

PowerPAD™ TSSOP - 1.2 mm max height

SMALL OUTLINE PACKAGE

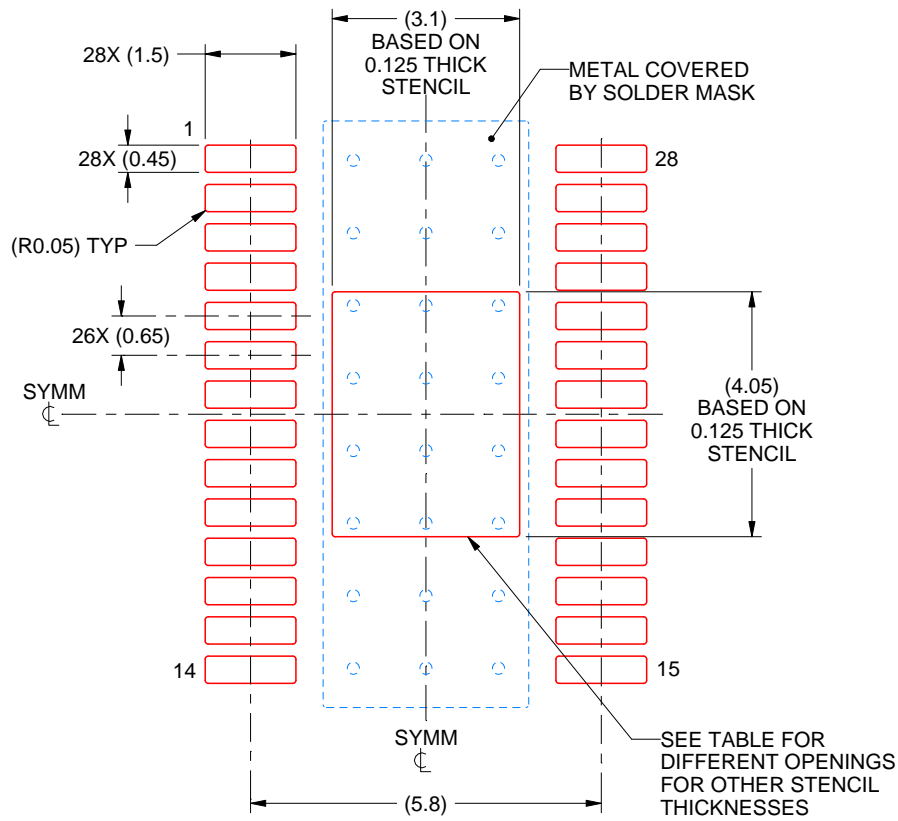

SOLDER PASTE EXAMPLE
 BASED ON 0.125 mm THICK STENCIL
 SCALE: 8X

STENCIL THICKNESS	SOLDER STENCIL OPENING
0.1	3.47 X 4.53
0.125	3.10 X 4.05 (SHOWN)
0.15	2.83 X 3.70
0.175	2.62 X 3.42

4224480/A 08/2018

NOTES: (continued)

11. Laser cutting apertures with trapezoidal walls and rounded corners may offer better paste release. IPC-7525 may have alternate design recommendations.
12. Board assembly site may have different recommendations for stencil design.

RGE 24

GENERIC PACKAGE VIEW

VQFN - 1 mm max height

PLASTIC QUAD FLATPACK - NO LEAD

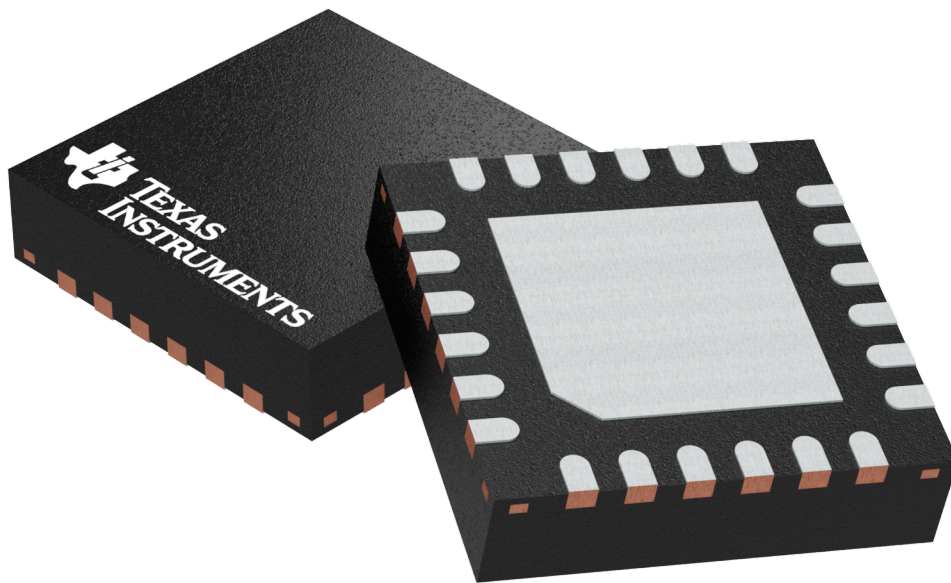

Images above are just a representation of the package family, actual package may vary.
Refer to the product data sheet for package details.

4204104/H

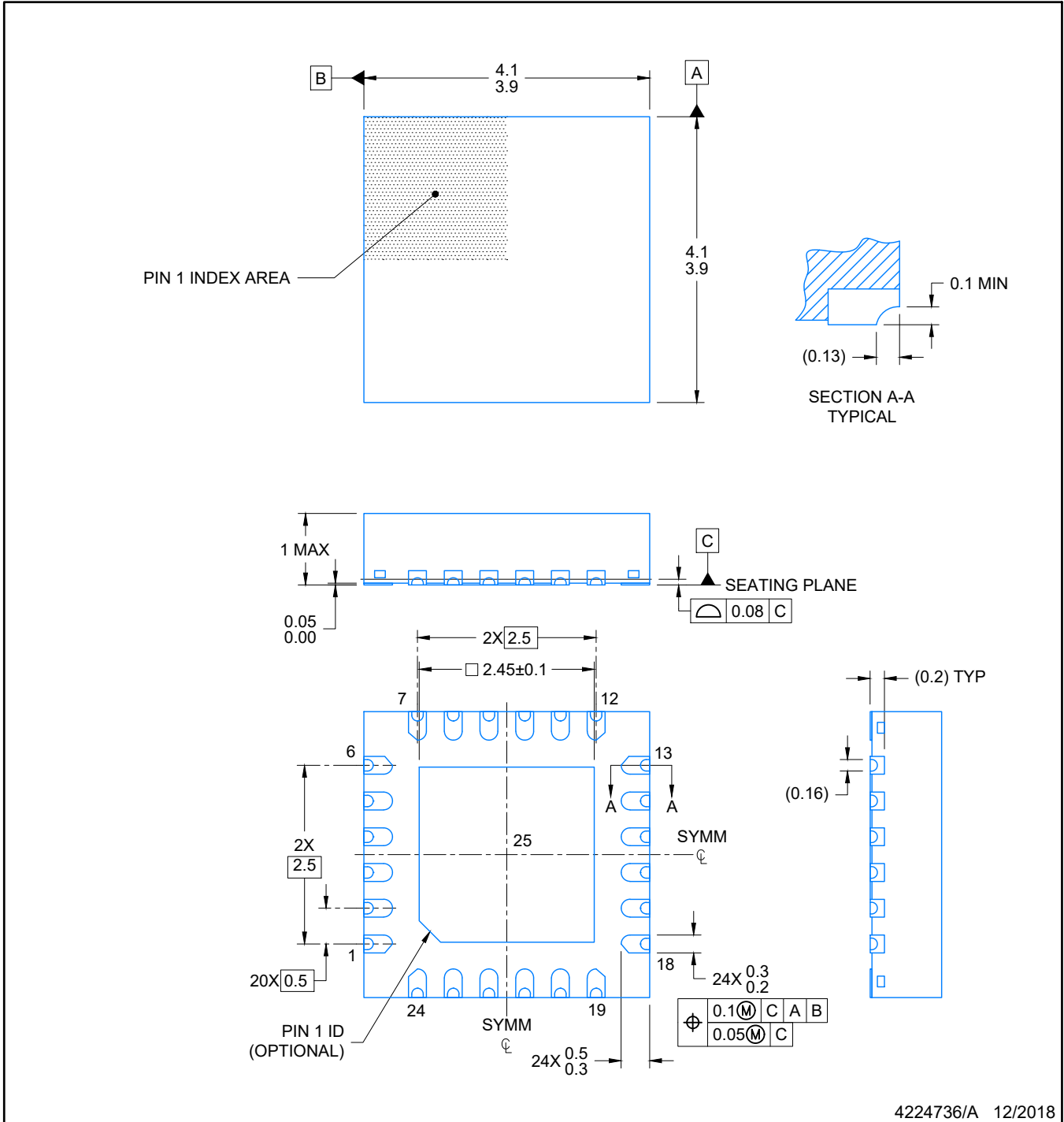

NOTES:

1. All linear dimensions are in millimeters. Any dimensions in parenthesis are for reference only. Dimensioning and tolerancing per ASME Y14.5M.
2. This drawing is subject to change without notice.
3. The package thermal pad must be soldered to the printed circuit board for optimal thermal and mechanical performance.

EXAMPLE STENCIL DESIGN

VQFN - 1 mm max height

RGE0024N

PLASTIC QUAD FLATPACK-NO LEAD

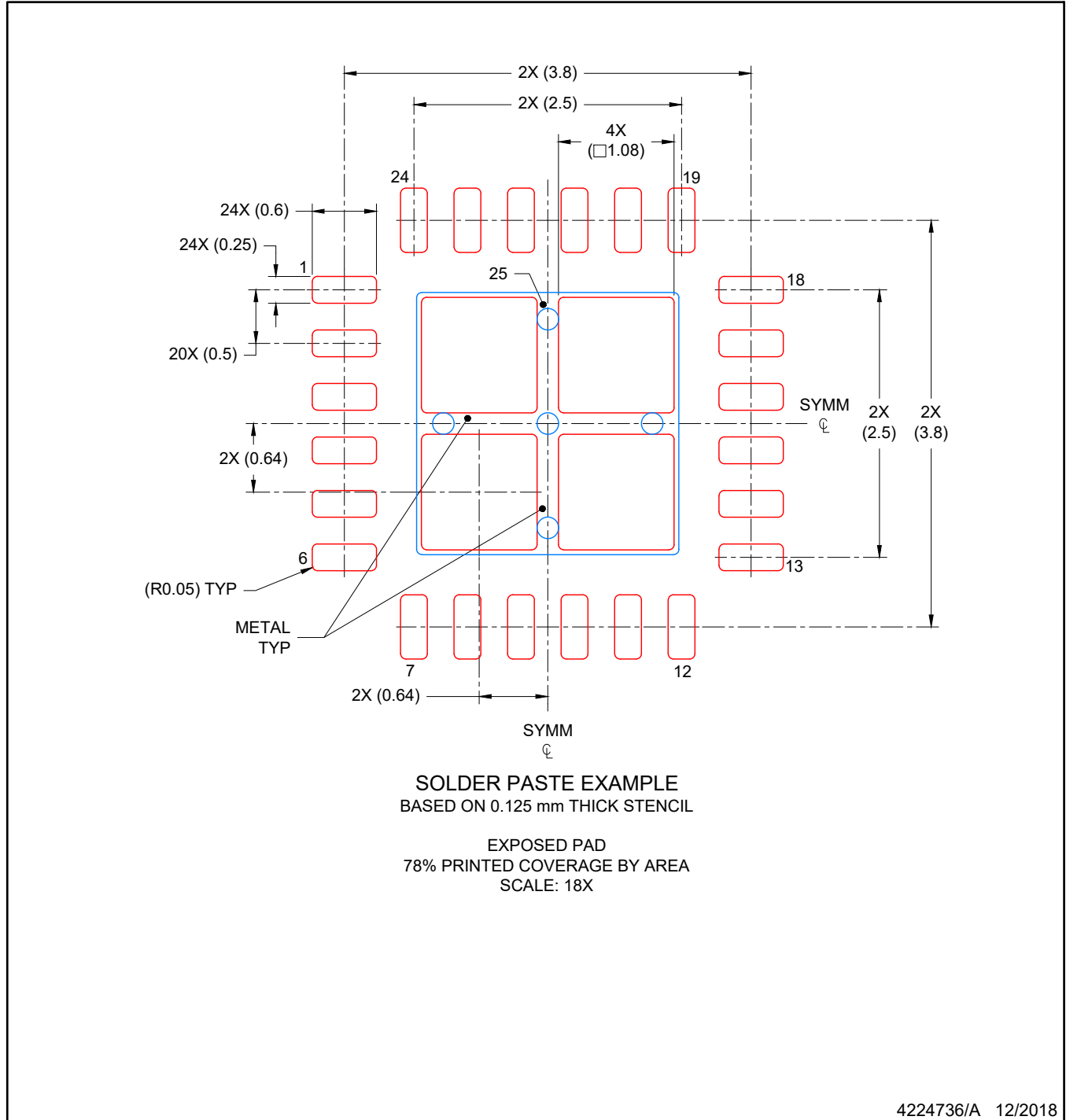

NOTES: (continued)

6. Laser cutting apertures with trapezoidal walls and rounded corners may offer better paste release. IPC-7525 may have alternate design recommendations.

IMPORTANT NOTICE AND DISCLAIMER

TI PROVIDES TECHNICAL AND RELIABILITY DATA (INCLUDING DATASHEETS), DESIGN RESOURCES (INCLUDING REFERENCE DESIGNS), APPLICATION OR OTHER DESIGN ADVICE, WEB TOOLS, SAFETY INFORMATION, AND OTHER RESOURCES "AS IS" AND WITH ALL FAULTS, AND DISCLAIMS ALL WARRANTIES, EXPRESS AND IMPLIED, INCLUDING WITHOUT LIMITATION ANY IMPLIED WARRANTIES OF MERCHANTABILITY, FITNESS FOR A PARTICULAR PURPOSE OR NON-INFRINGEMENT OF THIRD PARTY INTELLECTUAL PROPERTY RIGHTS.

These resources are intended for skilled developers designing with TI products. You are solely responsible for (1) selecting the appropriate TI products for your application, (2) designing, validating and testing your application, and (3) ensuring your application meets applicable standards, and any other safety, security, regulatory or other requirements.

These resources are subject to change without notice. TI grants you permission to use these resources only for development of an application that uses the TI products described in the resource. Other reproduction and display of these resources is prohibited. No license is granted to any other TI intellectual property right or to any third party intellectual property right. TI disclaims responsibility for, and you fully indemnify TI and its representatives against any claims, damages, costs, losses, and liabilities arising out of your use of these resources.

TI's products are provided subject to [TI's Terms of Sale](#), [TI's General Quality Guidelines](#), or other applicable terms available either on [ti.com](#) or provided in conjunction with such TI products. TI's provision of these resources does not expand or otherwise alter TI's applicable warranties or warranty disclaimers for TI products. Unless TI explicitly designates a product as custom or customer-specified, TI products are standard, catalog, general purpose devices.

TI objects to and rejects any additional or different terms you may propose.

Copyright © 2026, Texas Instruments Incorporated

Last updated 10/2025

Looking for pricing, stock, or lifecycle information?

Click below to explore more details on WIN SOURCE:

 [View USL00-30L-A on WIN SOURCE](#)

 [KEL Corporation Information](#)

Optimize Your Supply Chain with WIN SOURCE Solutions

-  Global Sourcing Solution
-  Obsolete Management
-  Cost Control Management
-  Shortage Management
-  Alternative Solution
-  Excess Inventory Management