



The following document contains information on Cypress products. Although the document is marked with the name “Broadcom”, the company that originally developed the specification, Cypress will continue to offer these products to new and existing customers.

CONTINUITY OF SPECIFICATIONS

There is no change to this document as a result of offering the device as a Cypress product. Any changes that have been made are the result of normal document improvements and are noted in the document history page, where supported. Future revisions will occur when appropriate, and changes will be noted in a document history page.

CONTINUITY OF ORDERING PART NUMBERS

Cypress continues to support existing part numbers. To order these products, please use only the Ordering Part Numbers listed in this document.

FOR MORE INFORMATION

Please visit our website at www.cypress.com or contact your [local sales office](#) for additional information about Cypress products and services.

OUR CUSTOMERS

Cypress is for true innovators – in companies both large and small.

Our customers are smart, aggressive, out-of-the-box thinkers who design and develop game-changing products that revolutionize their industries or create new industries with products and solutions that nobody ever thought of before.

ABOUT CYPRESS

Founded in 1982, Cypress is the leader in advanced embedded system solutions for the world's most innovative automotive, industrial, home automation and appliances, consumer electronics and medical products. Cypress's programmable systems-on-chip, general-purpose microcontrollers, analog ICs, wireless and USB-based connectivity solutions and reliable, high-performance memories help engineers design differentiated products and get them to market first.

Cypress is committed to providing customers with the best support and engineering resources on the planet enabling innovators and out-of-the-box thinkers to disrupt markets and create new product categories in record time. To learn more, go to www.cypress.com.

Not Recommended for New Designs

Single Chip IEEE 802.11™ a/b/g/n MAC/Baseband/ Radio with Integrated Bluetooth® 4.0 + HS and FM Transceiver

GENERAL DESCRIPTION

The Broadcom® BCM4330 single chip device provides for the highest level of integration for a mobile or handheld wireless system, with integrated IEEE 802.11™ a/b/g and single-stream 802.11n (MAC/baseband/radio), Bluetooth® 4.0 + HS, and FM radio receiver and transmitter. It includes on-chip 2.4 GHz and 5 GHz WLAN CMOS power amplifiers that meet the output power requirements of most handheld systems while permitting an optional external power amplifier for higher output power applications, if required.

Utilizing advanced design techniques and process technology to reduce active and idle power, the BCM4330 is designed to address the needs of highly mobile devices that require minimal power consumption and compact size. It includes a power management unit which simplifies the system power topology and allows for operation directly from a mobile platform battery while maximizing battery life.

FEATURES

The BCM4330 implements the highly sophisticated Enhanced Collaborative Coexistence radio coexistence algorithms and hardware mechanisms, allowing for an extremely collaborative Bluetooth coexistence scheme along with coexistence support for external radios (such as GPS, WiMax, or Ultra Wide-band radio technologies, as well as cellular radios) and a single shared antenna (2.4 GHz antenna for Bluetooth and WLAN). As a result, enhanced overall quality for simultaneous voice, video, and data transmission on a handheld system is achieved.

For the WLAN section, two alternative host interface options are included: an SDIO v2.0 interface that can operate in 4b, 1b, or gSPI modes, and an HSIC interface. An independent, high-speed UART is provided for the Bluetooth host interface. Package options include 4.89 mm x 5.33 mm WLPGA and WLCSP, and 6.5 mm x 6.5 mm FCFBGA.

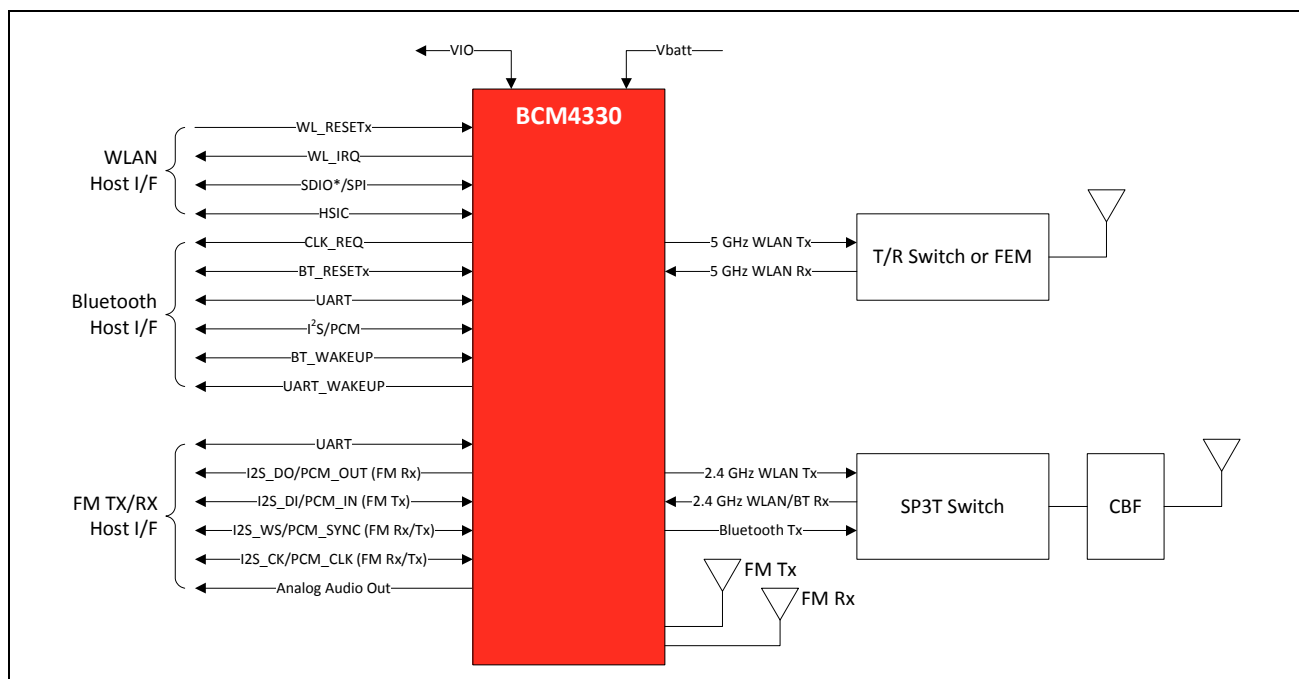

Figure 1: Functional Block Diagram

Not Recommended for New Designs

FEATURES**IEEE 802.11x Key Features**

- Single-band 2.4 GHz 802.11 b/g/n or dual-band 2.4 GHz and 5 GHz 802.11 a/b/g/n (non-simultaneous)
- Single stream 802.11n support for 20 MHz channels provides PHY layer rates up to MCS7 (72 Mbps) for typical upper-layer throughput in excess of 45 Mbps.
- Integrated CMOS power amplifiers with internal power-detectors and closed-loop power control can deliver greater than 18 dBm of linear output power (in 2.4 GHz band).
- PAs can be powered directly from VBAT, eliminating the need for a PALDO.
- Up to 8 RF control signals are available to support optional external PAs for higher output power and LNAs for enhanced sensitivity.
- Supports a single 2.4 GHz antenna shared between WLAN and Bluetooth.
- Shared Bluetooth and WLAN receive signal path eliminates the need for an external power splitter while maintaining excellent sensitivity for both Bluetooth and WLAN.
- Internal fractional nPLL allows support for a wide range of reference clock frequencies
- Supports IEEE 802.15.2 external three-wire coexistence scheme to optimize bandwidth utilization with other co-located wireless technologies such as GPS, WiMax, or UWB
- Supports standard SDIO v2.0 (50 MHz, 4-bit and 1-bit), and gSPI (48 MHz) host interfaces.
- Alternative host interface supports HSIC (a USB 2.0 derivative for short-distance, on-board connections).
- Integrated ARM® Cortex-M3 processor and on-chip memory for complete WLAN subsystem functionality, minimizing the need to wake up the applications processor for standard WLAN functions. This allows for further minimization of power consumption, while maintaining the ability to field upgrade with future features.
- OneDriver™ software architecture for easy migration from existing embedded WLAN and Bluetooth devices as well as future devices.

FEATURES**Bluetooth and FM Key Features**

- Bluetooth Core Specification Version 4.0 + HS compliant with provisions for supporting future specifications
- Bluetooth Class 1 or Class 2 transmitter operation
- Supports extended Synchronous Connections (eSCO), for enhanced voice quality by allowing for retransmission of dropped packets
- Adaptive Frequency Hopping (AFH) for reducing radio frequency interference
- Interface support — Host Controller Interface (HCI) using a high-speed UART interface and PCM for audio data
- The FM unit supports HCI for communication, stereo analog input and output
- Low-power consumption improves battery life of handheld devices
- FM receiver: 65 MHz to 108 MHz FM bands; supports the European Radio Data Systems (RDS) and the North American Radio Broadcast Data System (RBDS) standards
- Supports multiple simultaneous Advanced Audio Distribution Profiles (A2DP) for stereo sound
- Automatic frequency detection for standard crystal and TCXO values
- FM transmitter: 65 MHz to 108 MHz bands; supports both RDS and the RBDS standards and programmable output power.

General Features

- Supports battery voltage range from 2.3V to 4.8V supplies with internal switching regulator
- Programmable dynamic power management
- 2 Kbit OTP for storing board parameters
- Package options:
 - 144 ball FCBGA (6.5 mm x 6.5 mm, 0.5 mm pitch)
 - 133 ball WLBGA (4.89 mm x 5.33 mm, 0.4 mm pitch)
 - 225 bump WLCSP (4.89 mm x 5.33 mm, 0.2 mm pitch)
- Security:
 - WPA™- and WPA2™- (Personal) support for powerful encryption and authentication
 - AES and TKIP in hardware for faster data encryption and 802.11i compatibility
 - Reference WLAN subsystem provides Cisco® Compatible Extension- (CCX, CCX 2.0, CCX 3.0, CCX 4.0, CCX 5.0) certified
 - Reference WLAN subsystem provides Wi-Fi Protected Setup (WPS)
- Worldwide regulatory support: Global products supported with worldwide homologated design

Revision History

<i>Revision</i>	<i>Date</i>	<i>Change Description</i>
002-14939 *E	09/19/16	Parts in this datasheet are not recommended for new designs.
4330-DS304-R	4/28/11	<p>Updated:</p> <ul style="list-style-type: none"> • Global change: the maximum voltage for VBAT, VDD_PA, CBUCK, and LDO3P3, LDO3P1 was changed to 4.8V throughout the document. • “General Features” on page 3 • “External 32.768 kHz Low Power Oscillator” on page 37 • Table 18: “FCFBGA, WLPGA, and WLCSP Signal Descriptions,” on page 105 • Table 19: “WLAN GPIO Functions and Strapping Options,” on page 112 • Table 26: “ESD Specifications,” on page 118 • Table 27: “Recommended Operating Conditions and DC Characteristics,” on page 119 • Table 31: “FM Transmitter Specifications,” on page 126 • Table 32: “FM Receiver Specifications,” on page 128 • Table 34: “WLAN 2.4 GHz Receiver Performance Specifications,” on page 134 • Table 36: “WLAN 5 GHz Receiver Performance Specifications,” on page 139 • Table 39: “Core Buck Regulator (CBUCK) Specifications,” on page 143 • Table 40: “LDO3p1 Specifications,” on page 144 • Table 41: “LDO3p3 Specifications,” on page 145 • Table 42: “CLDO Specifications,” on page 146 • Table 43: “LNLDO1 Specifications,” on page 147 • Table 46: “Bluetooth and FM Current Consumption,” on page 151 <p>Added:</p> <ul style="list-style-type: none"> • Table 20: “Strap Options,” on page 112 • “HSIC Interface Specifications” on page 156

Not Recommended for New Designs

Revision	Date	Change Description
4330-DS303-R	1/26/11	<p>Added:</p> <ul style="list-style-type: none"> • “Bluetooth Low Energy” on page 37. • Table 23: “I/O States,” on page 108. • Table 45: “HSIC Power Consumption,” on page 142. • Figure 51: “WLAN Warm Reset,” on page 153. <p>Updated:</p> <ul style="list-style-type: none"> • Figure 2: “BCM4330 Block Diagram,” on page 17. • “Power Supply Topology” on page 22. • Figure 4: “Typical Power Topology,” on page 23. • Table 1: “Reset Control Signals,” on page 26. • Figure 7: “Recommended Circuit to Use with an External Shared TCXO,” on page 28. • “Features” on page 33. • “Bluetooth Radio” on page 35. • “Bluetooth 4.0 Features” on page 37. • Table 4: “Power Control Pin Description,” on page 39. • Figure 8: “Startup Signaling Sequence,” on page 40. • “RAM, ROM, and Patch Memory” on page 46. • “I2S Interface” on page 57. • “Audio Features” on page 62. • “WLAN CPU and Memory Subsystem” on page 66. • “External Coexistence Interface” on page 67. • Figure 34: “WLAN MAC Architecture,” on page 80. • Figure 37: “Radio Functional Block Diagram,” on page 87. • Figure 38: “144-FCFBGA Ball Map (top view),” on page 88. • Figure 39: “133-WLBGA Ball Map (bottom view),” on page 89. • Table 18: “FCFBGA, WLBGA, and WLCSP Signal Descriptions,” on page 98. • Table 21: “GPIO Multiplexing Matrix,” on page 106. • Table 22: “Multiplexed GPIO Signals,” on page 107. • Table 26: “ESD Specifications,” on page 111. • Table 27: “Recommended Operating Conditions and DC Characteristics,” on page 112. • Table 28: “Bluetooth Receiver RF Specifications,” on page 115. • Table 29: “Bluetooth Transmitter RF Specifications,” on page 116. • Table 30: “Local Oscillator Performance,” on page 118. • Table 31: “FM Transmitter Specifications,” on page 119. • Table 32: “FM Receiver Specifications,” on page 121. • Figure 42: “FM Receiver Circuit,” on page 125. • Table 34: “WLAN 2.4 GHz Receiver Performance Specifications,” on page 127. • Table 35: “WLAN 2.4 GHz Transmitter Performance Specifications,” on page 130.

Revision	Date	Change Description
4330-DS303-R (continued)	1/26/11	<p>Updated:</p> <ul style="list-style-type: none"> • Table 39: “Core Buck Regulator (CBUCK) Specifications,” on page 136. • Table 41: “LDO3p3 Specifications,” on page 138. • Table 42: “CLDO Specifications,” on page 138. • Table 43: “LNLDO1 Specifications,” on page 140. • Table 44: “WLAN Power Consumption (Ivbat+Ivio),” on page 141. • Table 46: “Bluetooth and FM Current Consumption,” on page 143. • Figure 53: “133-Ball WLBGA Package Mechanical Information,” on page 156. • “WLCSP Package Keep-Out Area” on page 158. • Table 53: “Ordering Information,” on page 159. <p>Removed:</p> <ul style="list-style-type: none"> • Section 9: “Enhanced Scanning Algorithm”.
4330-DS302-R	7/1/10	<p>Updated:</p> <ul style="list-style-type: none"> • Table 34 on page 125.

Not Recommended for New Designs

Revision	Date	Change Description
4330-DS301-R	6/24/10	<p>Added:</p> <ul style="list-style-type: none"> • Figure 6: “Recommended Circuit to Use with an External Dedicated TCXO,” on page 26. • Figure 7: “Recommended Circuit to Use with an External Shared TCXO,” on page 26. • “External 32.768 kHz Low Power Oscillator” on page 30. • Section 6: “Music and Audio,” on page 43. • Figure 37: “WLCSP 225-Bump Map (bottom view),” on page 87. <p>Updated:</p> <ul style="list-style-type: none"> • Figure 1: “Functional Block Diagram,” on page 1. • Figure 2: “BCM4330 Block Diagram,” on page 15. • “Features” on page 16. • Figure 3: “Mobile Phone Block System Diagram,” on page 19. • “Voltage Regulators” on page 20. • “Reset Circuits” on page 24. • Section 3: “Frequency References,” on page 25. • Table 2: “Crystal Oscillator and External Clock – Requirements and Performance,” on page 27. • Figure 7: “Recommended Circuit to Use with an External Shared TCXO,” on page 26. • Table 3: “External 32.768 kHz Sleep Clock Specifications,” on page 30. • “Bluetooth Radio” on page 33. • “Bluetooth Power Management Unit” on page 37. • Figure 8: “Startup Signaling Sequence,” on page 38. • “RAM, ROM, and Patch Memory” on page 44. • “PCM Interface” on page 45. • “UART Interface” on page 53. • “I2S Interface” on page 55. • Section 10: “FM Transceiver Subsystem,” on page 59. • “GPIO Interface” on page 64.

Revision	Date	Change Description
4330-DS301-R (continued)	6/24/10	<p>Updated:</p> <ul style="list-style-type: none"> • “JTAG Interface” on page 64. • Figure 35: “144-FCBGA Ball Map (top view),” on page 85. • Figure 36: “133-WLBGA Ball Map (bottom view),” on page 86. • Table 18: “WLCSP 225-Bump Coordinates,” on page 88. • Table 19: “FCBGA, WLBGA, and WLCSP Signal Descriptions,” on page 95. • Table 20: “WLAN GPIO Functions and Strapping Options (Advance Information),” on page 102. • Table 21: “GPIO Multiplexing Matrix,” on page 103. • Table 22: “Multiplexed GPIO Signals,” on page 104. • Table 23: “Absolute Maximum Ratings,” on page 105. • Table 24: “Environmental Ratings,” on page 106. • Table 26: “Recommended Operating Conditions and DC Characteristics,” on page 107. • Table 27: “Bluetooth Receiver RF Specifications,” on page 109. • Table 28: “Bluetooth Transmitter RF Specifications,” on page 110. • Table 29: “Local Oscillator Performance,” on page 112. • Table 30: “FM Transmitter Specifications,” on page 113. • Table 31: “FM Receiver Specifications,” on page 116. • Table 33: “WLAN 2.4 GHz Receiver Performance Specifications,” on page 122. • Table 34: “WLAN 2.4 GHz Transmitter Performance Specifications,” on page 125. • Table 35: “WLAN 5 GHz Receiver Performance Specifications,” on page 127. • Table 36: “WLAN 5 GHz Transmitter Performance Specifications,” on page 129. • Figure 39: “FM Receiver Circuit with External Balun and Cellular Band Blocking Filter,” on page 120. • Table 38: “Core Buck Regulator (CBUCK) Specifications,” on page 131. • Table 43: “WLAN Power Consumption (I_{vbat}+I_{vio}),” on page 135. • Table 44: “Bluetooth and FM Current Consumption,” on page 137. • Figure 49: “133-Ball WLBGA Package Mechanical Information,” on page 148. • Figure 50: “225-Bump WLCSP Package Mechanical Information,” on page 149. • “Ordering Information” on page 150. <p>Removed:</p> <ul style="list-style-type: none"> • Table 11: “OTP Select,” on page 70.
4330-DS300-R	10/28/09	Initial release.

Table of Contents

About This Document	19
Purpose and Audience	19
Acronyms and Abbreviations	19
Document Conventions	19
References	20
Technical Support	20
Section 1: BCM4330 Overview	21
Overview	21
Features	22
Standards Compliance	23
Mobile Phone Usage Model	24
Section 2: Power Supplies and Power Management	26
Power Supply Topology	26
Voltage Regulators.....	26
WLAN Power Management	28
PMU Sequencing	29
Low-Power Shutdown	30
Reset Circuits	31
Section 3: Frequency References	32
Crystal Interface and Clock Generation	32
TCXO	33
Frequency Selection	36
External 32.768 kHz Low Power Oscillator	37
Section 4: Bluetooth + FM Subsystem Overview	38
Features	38
Bluetooth Radio	40
Transmit.....	40
Digital Modulator.....	40
Digital Demodulator and Bit Synchronizer.....	40
Power Amplifier	40
Receiver	41
Digital Demodulator and Bit Synchronizer.....	41
Receiver Signal Strength Indicator.....	41

Local Oscillator Generation.....	41
Calibration.....	41
Section 5: Bluetooth Baseband Core.....	42
Bluetooth 4.0 Features.....	42
Bluetooth Low Energy	42
Link Control Layer	43
Test Mode Support.....	43
Bluetooth Power Management Unit	44
RF Power Management	44
Host Controller Power Management.....	45
BBC Power Management	47
FM Power Management	47
Low-Power Scan.....	47
Wideband Speech	47
Packet Loss Concealment	48
Audio Rate-Matching Algorithms	48
Codec Encoding.....	49
Multiple Simultaneous A2DP Audio Stream	49
FM Over Bluetooth	49
Burst Buffer Operation	49
Adaptive Frequency Hopping.....	49
Advanced Bluetooth/WLAN Coexistence	50
Fast Connection (Interlaced Page and Inquiry Scans)	50
Section 6: Music and Audio	51
MP3 Encoder.....	51
MP3 Decoder	51
AAC/AAC+ Decoder	51
Section 7: Microprocessor and Memory Unit for Bluetooth.....	52
RAM, ROM, and Patch Memory.....	52
Reset	52
Section 8: Bluetooth Peripheral Transport Unit	53
PCM Interface	53
Slot Mapping.....	53
Frame Synchronization	53
Data Formatting.....	53

Not Recommended for New Designs

Wideband Speech Support	54
Multiplexed Bluetooth and FM Over PCM.....	54
Burst PCM Mode.....	54
PCM Interface Timing	55
Short Frame Sync, Master Mode	55
Short Frame Sync, Slave Mode	56
Long Frame Sync, Master Mode	57
Long Frame Sync, Slave Mode	58
Short Frame Sync, Burst Mode	59
Long Frame Sync, Burst Mode	60
UART Interface	61
I²S Interface	63
I ² S Timing	63
Section 9: FM Transceiver Subsystem	66
FM Radio	66
Digital FM Audio Interfaces.....	66
Analog FM Audio Interfaces.....	66
FM Over Bluetooth	66
eSCO	67
Wide Band Speech Link	67
A2DP	67
Dynamic Antenna Switching	67
Autotune and Search Algorithms.....	68
Audio Features	68
On-Chip MP3 Encoding.....	70
RDS/RBDS	71
Section 10: WLAN Global Functions.....	72
WLAN CPU and Memory Subsystem.....	72
One-Time-Programmable Memory.....	72
GPIO Interface	73
External Coexistence Interface	73
UART Interface	73
JTAG Interface	73
Section 11: WLAN Host Interfaces	74
SDIO v2.0	74

Not Recommended for New Designs

SDIO Pin Descriptions	74
Generic SPI Mode	76
SPI Protocol	77
Command Structure	78
Write	78
Write/Read	78
Read	78
Status	79
gSPI Host-Device Handshake	81
Boot-Up Sequence	81
HSIC Interface	84
Section 12: Wireless LAN MAC and PHY	85
MAC Features	85
MAC Description	85
PSM	87
WEP	87
TXE	88
RXE	88
IFS	89
TSF	89
NAV	89
MAC-PHY Interface	89
WLAN PHY Description	90
PHY Features	90
Section 13: WLAN Radio Subsystem	93
Receive Path	93
Transmit Path	93
Calibration	93
Section 14: Pinout and Signal Descriptions	95
Signal Assignments	95
WLAN GPIO Signals and Strapping Options	112
Muxed Bluetooth GPIO Signals	113
I/O States	115
Section 15: DC Characteristics	117
Absolute Maximum Ratings	117

Not Recommended for New Designs

Environmental Ratings	118
Electrostatic Discharge Specifications	118
Recommended Operating Conditions and DC Characteristics	119
Section 16: Bluetooth RF Specifications	121
Section 17: FM Transmitter Specifications	126
Section 18: FM Receiver Specifications	128
Section 19: WLAN RF Specifications	133
Introduction	133
2.4 GHz Band General RF Specifications	134
WLAN 2.4 GHz Receiver Performance Specifications	134
WLAN 2.4 GHz Transmitter Performance Specifications	137
WLAN 5 GHz Receiver Performance Specifications	139
WLAN 5 GHz Transmitter Performance Specifications	141
General Spurious Emissions Specifications	142
Section 20: Internal Regulator Electrical Specifications	143
Core Buck Regulator	143
LDO3p1	144
LDO3p3	145
CLDO	146
LNLDO1	147
Section 21: System Power Consumption	148
WLAN Current Consumption	149
HSIC Power Consumption	150
Bluetooth and FM Current Consumption	151
Section 22: Interface Timing and AC Characteristics	152
SDIO/gSPI Timing	152
SDIO Default Mode Timing	152
SDIO High-Speed Mode Timing	154
gSPI Signal Timing	155
HSIC Interface Specifications	156
JTAG Timing	157
Section 23: Power-Up Sequence and Timing	158
Sequencing of Reset and Regulator Control Signals	158
Description of Control Signals	159

Control Signal Timing Diagrams	159
Section 24: Package Information	162
Package Thermal Characteristics	162
Junction Temperature Estimation and Ψ_{JT} Versus Θ_{JC}	162
Environmental Characteristics	162
Section 25: Mechanical Information	163
WLCSP Package Keep-Out Area	166
Section 26: Ordering Information	167

Not Recommended for New Designs

List of Figures

Figure 1: Functional Block Diagram	2
Figure 2: BCM4330 Block Diagram	21
Figure 3: Mobile Phone Block System Diagram.....	25
Figure 4: Typical Power Topology.....	27
Figure 5: Recommended Oscillator Configuration	32
Figure 6: Recommended Circuit to Use with an External Dedicated TCXO.....	33
Figure 7: Recommended Circuit to Use with an External Shared TCXO.....	33
Figure 8: Startup Signaling Sequence	46
Figure 9: CVSD Decoder Output Waveform Without PLC	48
Figure 10: CVSD Decoder Output Waveform After Applying PLC	48
Figure 11: Functional Multiplex Data Diagram.....	54
Figure 12: PCM Timing Diagram (Short Frame Sync, Master Mode).....	55
Figure 13: PCM Timing Diagram (Short Frame Sync, Slave Mode).....	56
Figure 14: PCM Timing Diagram (Long Frame Sync, Master Mode).....	57
Figure 15: PCM Timing Diagram (Long Frame Sync, Slave Mode).....	58
Figure 16: PCM Burst Mode Timing (Receive Only, Short Frame Sync)	59
Figure 17: PCM Burst Mode Timing (Receive Only, Long Frame Sync)	60
Figure 18: UART Timing	62
Figure 19: I ² S Transmitter Timing.....	65
Figure 20: I ² S Receiver Timing.....	65
Figure 21: Example Blend/Switch Usage	69
Figure 22: Example Blend/Switch Separation	69
Figure 23: Example Soft Mute Characteristic	70
Figure 24: Signal Connections to SDIO Host (SD 4-Bit Mode)	75
Figure 25: Signal Connections to SDIO Host (SD 1-Bit Mode)	75
Figure 26: Signal Connections to SDIO Host (gSPI Mode)	76
Figure 27: gSPI Write Protocol	77
Figure 28: gSPI Read Protocol	77
Figure 29: gSPI Command Structure.....	78
Figure 30: gSPI Signal Timing Without Status.....	79
Figure 31: gSPI Signal Timing with Status (Response Delay = 0)	80
Figure 32: WLAN Boot-Up Sequence.....	83
Figure 33: HSIC Device Block Diagram.....	84
Figure 34: WLAN MAC Architecture	86
Figure 35: WLAN PHY Block Diagram	91

Figure 36: STBC Receive Block Diagram	92
Figure 37: Radio Functional Block Diagram.....	94
Figure 38: 144-FCFBGA Ball Map (Top View)	95
Figure 39: 133-WLBGA Ball Map (bottom view)	96
Figure 40: WLCSP 225-Bump Map (bottom view).....	97
Figure 41: RF Port Location for Bluetooth Testing	121
Figure 42: FM Receiver Circuit	132
Figure 43: Port Locations.....	133
Figure 44: SDIO Bus Timing (Default Mode).....	152
Figure 45: SDIO Bus Timing (High-Speed Mode)	154
Figure 46: gSPI Timing	155
Figure 47: WLAN = ON, Bluetooth = ON.....	159
Figure 48: WLAN = OFF, Bluetooth = OFF.....	160
Figure 49: WLAN = ON, Bluetooth = OFF.....	160
Figure 50: WLAN = OFF, Bluetooth = ON.....	161
Figure 51: WLAN Warm Reset.....	161
Figure 52: 144-Ball FCFBGA Package Mechanical Information	163
Figure 53: 133-Ball WLBGA Package Mechanical Information.....	164
Figure 54: 225-Bump WLCSP Package Mechanical Information	165
Figure 55: WLCSP Package Keep-outs	166

List of Tables

Table 1: Reset Control Signals	31
Table 2: Crystal Oscillator and External Clock – Requirements and Performance	34
Table 3: External 32.768 kHz Sleep Clock Specifications	37
Table 4: Power Control Pin Description	45
Table 5: PCM Interface Timing Specifications (Short Frame Sync, Master Mode)	55
Table 6: PCM Interface Timing Specifications (Short Frame Sync, Slave Mode)	56
Table 7: PCM Interface Timing Specifications (Long Frame Sync, Master Mode)	57
Table 8: PCM Interface Timing Specifications (Long Frame Sync, Slave Mode)	58
Table 9: PCM Burst Mode (Receive Only, Short Frame Sync)	59
Table 10: PCM Burst Mode (Receive Only, Long Frame Sync)	60
Table 11: Example of Common Baud Rates.....	61
Table 12: UART Timing Specifications	62
Table 13: Timing for I ² S Transmitters and Receivers.....	64
Table 14: SDIO Pin Description.....	74
Table 15: gSPI Status Field Details.....	80
Table 16: gSPI Registers.....	81
Table 17: WLCSP 225-Bump Coordinates.....	98
Table 18: FCBGA, WLPGA, and WLCSP Signal Descriptions.....	105
Table 19: WLAN GPIO Functions and Strapping Options	112
Table 20: Strap Options.....	112
Table 21: GPIO Multiplexing Matrix	113
Table 22: Multiplexed GPIO Signals.....	114
Table 23: I/O States.....	115
Table 24: Absolute Maximum Ratings.....	117
Table 25: Environmental Ratings.....	118
Table 26: ESD Specifications.....	118
Table 27: Recommended Operating Conditions and DC Characteristics	119
Table 28: Bluetooth Receiver RF Specifications	122
Table 29: Bluetooth Transmitter RF Specifications	123
Table 30: Local Oscillator Performance.....	125
Table 31: FM Transmitter Specifications.....	126
Table 32: FM Receiver Specifications	128
Table 33: 2.4 GHz Band General RF Specifications.....	134
Table 34: WLAN 2.4 GHz Receiver Performance Specifications	134
Table 35: WLAN 2.4 GHz Transmitter Performance Specifications.....	137

Table 36: WLAN 5 GHz Receiver Performance Specifications	139
Table 37: WLAN 5 GHz Transmitter Performance Specifications	141
Table 38: General Spurious Emissions Specifications	142
Table 39: Core Buck Regulator (CBUCK) Specifications	143
Table 40: LDO3p1 Specifications	144
Table 41: LDO3p3 Specifications	145
Table 42: CLDO Specifications	146
Table 43: LNLDO1 Specifications	147
Table 44: WLAN Power Consumption (I _{bat} +I _{vio})	149
Table 45: HSIC Power Consumption	150
Table 46: Bluetooth and FM Current Consumption	151
Table 47: SDIO Bus Timing Parameters (Default Mode).....	153
Table 48: SDIO Bus Timing Parameters (High-Speed Mode).....	154
Table 49: gSPI Timing Parameters	155
Table 50: HSIC Timing Parameters	156
Table 51: JTAG Timing Characteristics.....	157
Table 52: Package Thermal Characteristics	162
Table 53: Ordering Information	167

Not Recommended for New Designs

About This Document

Purpose and Audience

This document provides details of the functional, operational, and electrical characteristics of the Broadcom® BCM4330. It is intended for hardware design, application, and OEM engineers.

Acronyms and Abbreviations

In most cases, acronyms and abbreviations are defined on first use.

For a comprehensive list of acronyms and other terms used in Broadcom documents, go to:
<http://www.broadcom.com/press/glossary.php>.

Document Conventions

The following conventions may be used in this document:

<i>Convention</i>	<i>Description</i>
Bold	User input and actions: for example, type exit , click OK , press Alt+C
Monospace	Code: <code>#include <iostream></code> HTML: <code><td rowspan = 3></code> Command line commands and parameters: <code>wl [-1] <command></code>
< >	Placeholders for <i>required</i> elements: enter your <username> or <code>wl <command></code>
[]	Indicates <i>optional</i> command-line parameters: <code>wl [-1]</code> Indicates bit and byte ranges (inclusive): <code>[0:3]</code> or <code>[7:0]</code>

References

The references in this section may be used in conjunction with this document.



Note: Broadcom provides customer access to technical documentation and software through its Customer Support Portal (CSP) and Downloads & Support site (see [Technical Support](#)).

For Broadcom documents, replace the “xx” in the document number with the largest number available in the repository to ensure that you have the most current version of the document.

<i>Document (or Item) Name</i>	<i>Number</i>	<i>Source</i>
Broadcom Items		
[1] <i>Printed Circuit Board Layout Guidelines and Component Selection for Optimized PMU Performance</i>	4330_4336_AN1xx-R	CSP

Technical Support

Broadcom provides customer access to a wide range of information, including technical documentation, schematic diagrams, product bill of materials, PCB layout information, and software updates through its customer support portal (<https://support.broadcom.com>). For a CSP account, contact your Sales or Engineering support representative.

In addition, Broadcom provides other product support through its Downloads & Support site (<http://www.broadcom.com/support/>).

Section 1: BCM4330 Overview

Overview

The Broadcom® BCM4330 single-chip device provides the highest level of integration for a mobile or handheld wireless system, with integrated IEEE 802.11™ a/b/g/n (MAC/baseband/radio), Bluetooth 4.0 + EDR (enhanced data rate), and FM transceiver. It provides a small form-factor solution with minimal external components to drive down cost for mass volumes and allows for handheld device flexibility in size, form, and function. Comprehensive power management circuitry and software ensure the system can meet the needs of highly mobile devices that require minimal power consumption and reliable operation.

Figure 2 shows the interconnect of all the major physical blocks in the BCM4330 and their associated external interfaces, which are described in greater detail in the following sections.

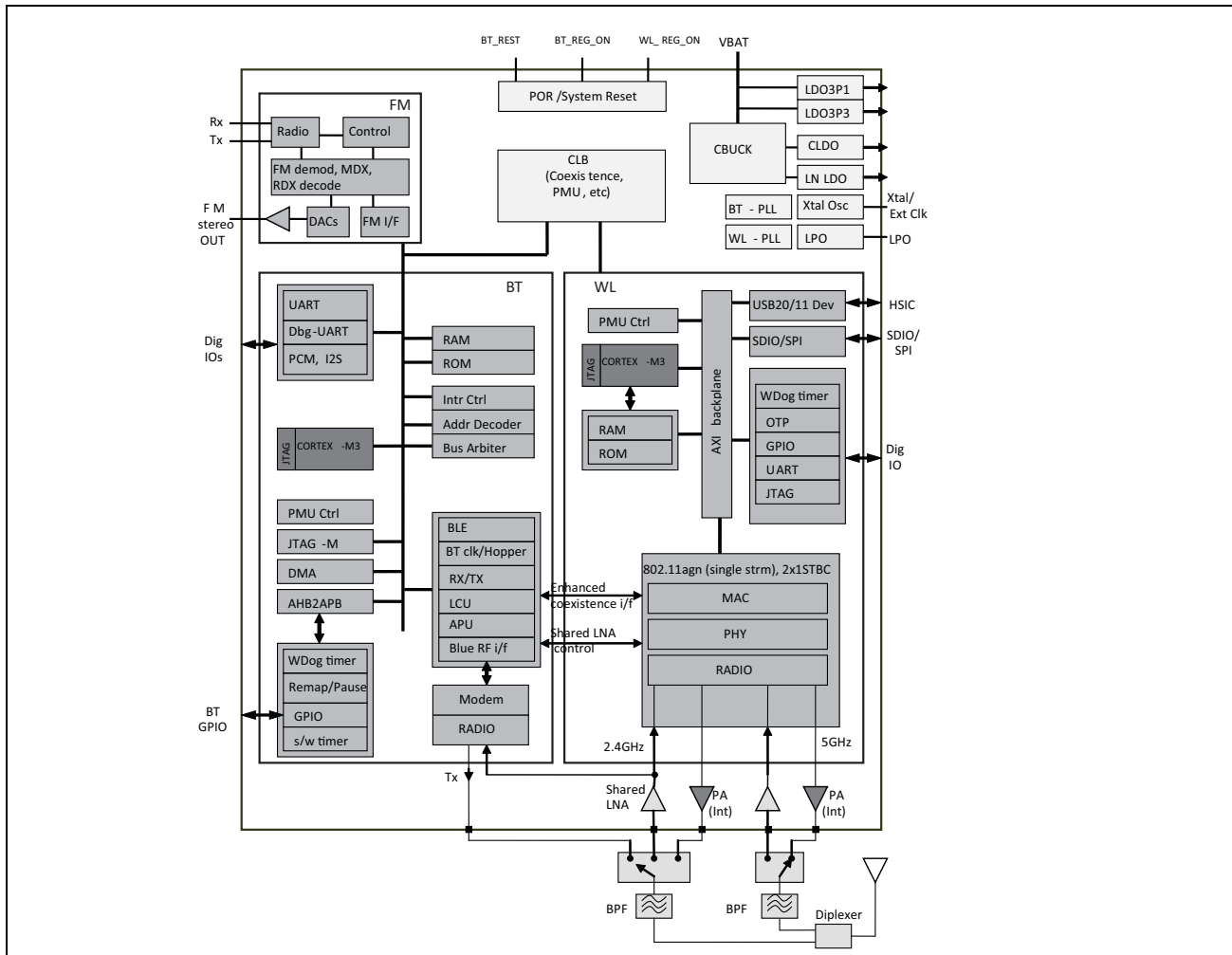

Figure 2: BCM4330 Block Diagram

Not Recommended for New Designs

Features

The BCM4330 supports the following features:

- 802.11a/b/g/n dual-band radio — non-simultaneous dual-band operation
- Bluetooth v4.0 + EDR with integrated Class 1 PA
- Concurrent Bluetooth, FM (RX) RDS/RBDS, and WLAN operation
- On-chip WLAN driver execution capable of supporting 802.11 functionality
- Single- and dual-antenna support
 - Single antenna without external switch (shared LNA)
 - Simultaneous BT/WLAN receive with single antenna
 - Support for a 2×1 dual receiver system
- WLAN host interface options:
 - SDIO v1.2x (1-bit/4-bit) — up to 50 MHz clock rate
 - gSPI — up to 48 MHz clock rate
 - HSIC (USB device interface for short distance on-board applications)
- BT host digital interface (can be used concurrently with above interfaces):
 - UART (up to 4 Mbps)
- ECI — enhanced coexistence support, ability to coordinate BT SCO transmissions around WLAN receives
- I²S/PCM for FM/BT audio, HCI for FM block control
- HCI high-speed UART (H4, H4+, H5) transport support
- Wideband speech support (16 bits linear data, MSB first, left justified at 4K samples/s for transparent air coding, both through I²S and PCM interface)
- Bluetooth SmartAudio technology improves voice and music quality to headsets
- Bluetooth low power inquiry and page scan
- Bluetooth Low Energy (BLE) support
- Bluetooth Packet Loss Concealment (PLC)
- Bluetooth Wide Band Speech (WBS)
- FM advanced internal antenna support
- FM auto search/tuning functions
- FM multiple audio routing options: I²S, PCM, eSCO, A2DP
- FM mono-stereo blend and switch, and soft mute support
- FM audio pause detect support
- Audio rate-matching algorithms
- Multiple simultaneous A2DP audio stream
- FM over Bluetooth operation and on-chip stereo headset emulation (SBC, MP3, and AAC+)
- MP3, AAC+ on-chip decoder for low power music playback

Standards Compliance

The BCM4330 supports the following standards:

- Bluetooth 2.1 + EDR
- Bluetooth 3.0 + HS
- Bluetooth 4.0 (Bluetooth Low Energy)
- 65 MHz to 108 MHz FM bands (US, Europe, and Japan)
- IEEE 802.11n — Handheld Device Class (Section 11)
- 802.11a
- 802.11b
- 802.11g
- 802.11d
- 802.11h
- 802.11i

The BCM4330 will support the following future drafts/standards:

- 802.11r — Fast Roaming (between APs)
- 802.11k — resource management
- 802.11w — Secure Management Frames
- 802.11 Extensions:
 - 802.11e QoS Enhancements (as per the WMM[®] specification is already supported)
 - 802.11h 5 GHz Extensions
 - 802.11i MAC Enhancements
 - 802.11r Fast Roaming Support
 - 802.11k Radio Resource Measurement
- Security:
 - WEP
 - WPA[™] Personal
 - WPA2[™] Personal
 - WMM
 - WMM-PS (U-APSD)
 - WMM-SA
 - AES (Hardware Accelerator)
 - TKIP (HW Accelerator)
 - CKIP (SW Support)

Not Recommended for New Designs

- Proprietary Protocols:
 - CCXv2
 - CCXv3
 - CCXv4
 - CCXv5
 - WFAEC
- 802.15.2 Coexistence Compliance — on silicon solution compliant with IEEE 3 wire requirements

Mobile Phone Usage Model

The BCM4330 incorporates a number of unique features to simplify integration into mobile phone platforms. Its flexible PCM and UART interfaces enable it to transparently connect with the existing circuits. In addition, the TCXO and LPO inputs allow the use of existing handset features to further minimize the size, power, and cost of the complete system.

- The PCM interface provides multiple modes of operation to support both master and slave as well as hybrid interfacing to single or multiple external codec devices.
- The UART interface supports hardware flow control with tight integration to power control sideband signaling to support the lowest power operation.
- The TCXO interface accommodates any of the typical reference frequencies used by cell phones.
- An analog FM receiver interface is available for legacy systems.
- FM digital interfaces can use either I²S or PCM.
- The highly linear design of the radio transceiver ensures that the device has the lowest spurious emissions output regardless of the state of operation. It has been fully characterized in the global cellular bands.
- The transceiver design has excellent blocking (eliminating desensitization of the Bluetooth receiver) and intermodulation performance (distortion of the transmitted signal caused by the mixing of the cellular and Bluetooth transmissions) in the presence of a any cellular transmission (GSM[®], GPRS, CDMA, WCDMA, or iDEN). Minimal external filtering is required for integration inside the handset.

The BCM4330 is designed to provide direct interface with new and existing handset designs as shown in [Figure 3 on page 25](#).

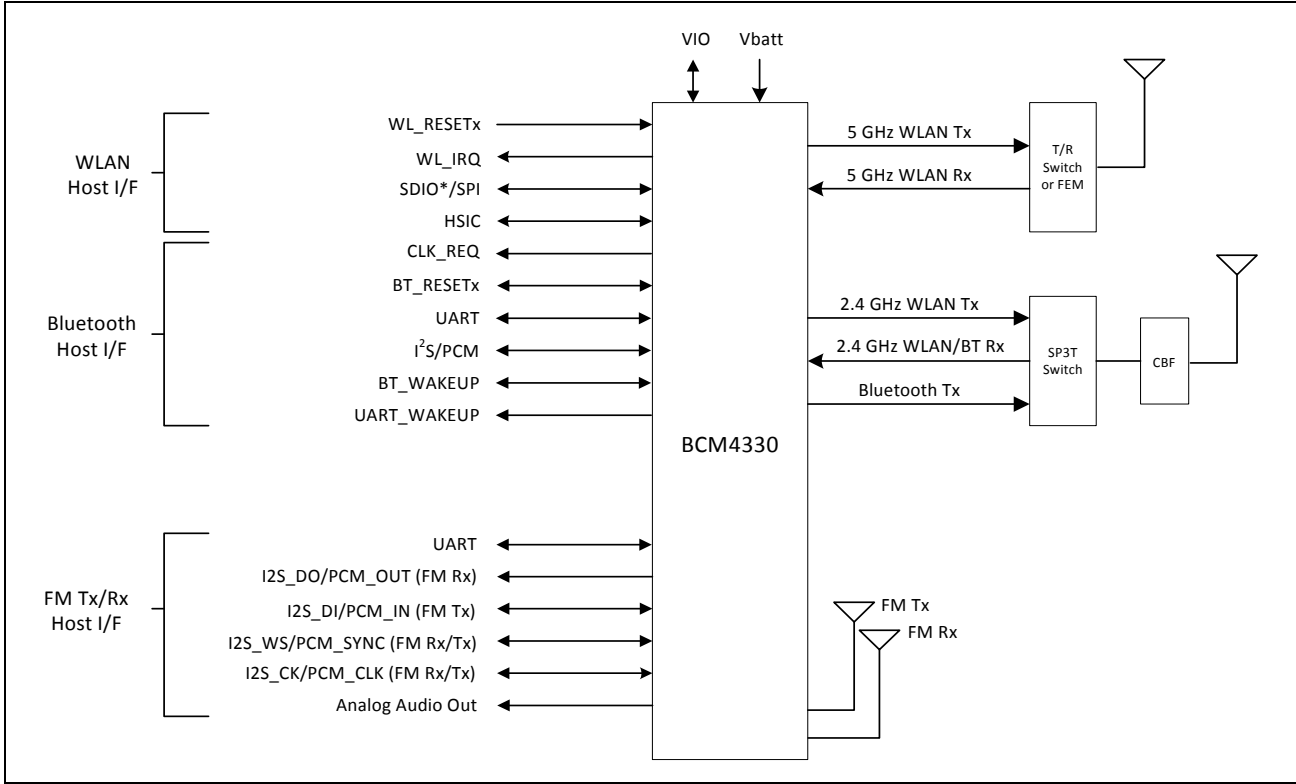

Figure 3: Mobile Phone Block System Diagram

Not Recommended for New Designs

Section 2: Power Supplies and Power Management

Power Supply Topology

One Buck regulator, four LDO regulators, and a Power Management Unit (PMU) are integrated into the BCM4330. All regulators are programmable via the PMU. These blocks simplify power supply design for Bluetooth, WLAN, and FM functions in embedded designs. All regulator inputs and outputs are brought out to pins on the BCM4330. This allows maximum flexibility for the system designer to choose which of the BCM4330 integrated regulators to use.

A single host power supply can be used (including VBATT ranging from 2.3V to 4.8V) with all additional voltages being provided by the regulators in the BCM4330.

Two control signals, BT_REG_ON and WL_REG_ON, are used to power-up the regulators. The CBuck CLDO and LNLDO power up when any of the reset signals are de-asserted. All regulators are powered down only when both resets are asserted. The CLDO and LNLDO may be turned off/on based on the dynamic demands of the digital baseband.

Voltage Regulators

All BCM4330 regulator output voltages are PMU-programmable and have the following nominal ratings. The currents listed below indicate the capabilities of each regulator. See [Section 21: "System Power Consumption," on page 148](#) for the actual operating loads.

- Core Buck switching regulator (CBUCK): 2.3–4.8V in; nominal 1.5V, up to 500 mA out
- LDO3p1: 2.3–4.8V in; nominal 2.5V, up to 80 mA out
- LDO3p3: 2.3–4.8 in; nominal 3.15V, up to 80 mA out
- CLDO (for the core): 1.5V in; nominal 1.2V, up to 150 mA out
- Low-noise LNLDO1: 1.5V in; nominal 1.2V, up to 300 mA out

Not Recommended for New Designs

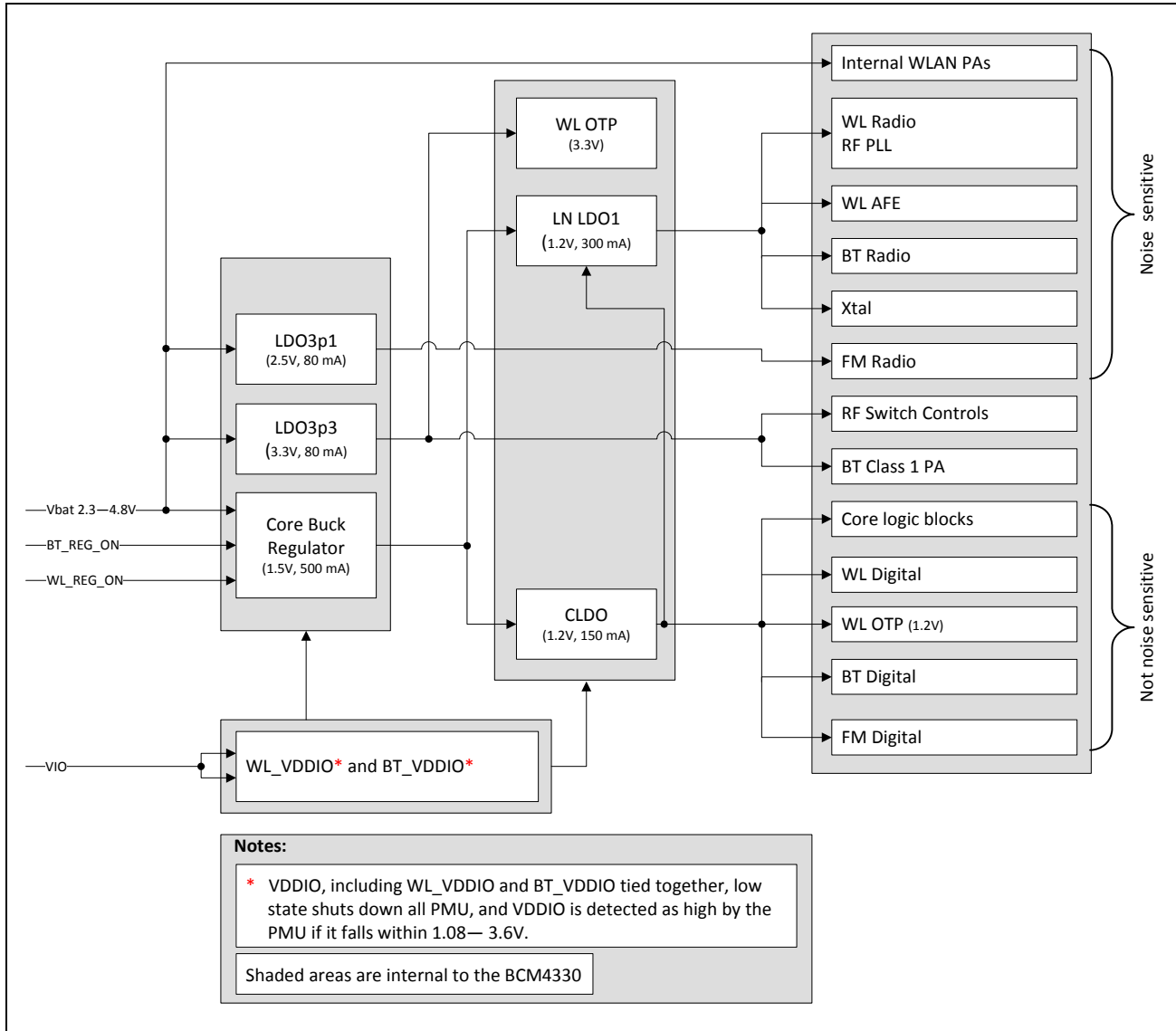

Figure 4: Typical Power Topology

Not Recommended for New Designs

WLAN Power Management

The BCM4330 has been designed with the stringent power consumption requirements of mobile devices in mind. All areas of the chip design are optimized to minimize power consumption. Silicon processes and cell libraries were chosen to reduce leakage current and supply voltages. Additionally, the BCM4330 integrated RAM is a high Vt memory with dynamic clock control. The dominant supply current consumed by the RAM is leakage current only. Additionally, the BCM4330 includes an advanced WLAN power management unit (PMU) sequencer. The PMU sequencer provides significant power savings by putting the BCM4330 into various power management states appropriate to the current environment and activities that are being performed. The power management unit enables and disables internal regulators, switches, and other blocks based on a computation of the required resources and a table that describes the relationship between resources and the time needed to enable and disable them. Power up sequences are fully programmable. Configurable, free-running counters (running at 32.768 kHz LPO clock) in the PMU sequencer are used to turn on/turn off individual regulators and power switches. Clock speeds are dynamically changed (or gated altogether) for the current mode. Slower clock speeds are used wherever possible.

The BCM4330 WLAN power states are described as follows:

- Active mode — All components in the BCM4330 are powered up and fully functional with active carrier sensing and frame transmission and receiving. All required regulators are enabled and put in the most efficient mode (PWM or Burst) based on the load current. Clock speeds are dynamically adjusted by the PMU sequencer.
- Doze mode — The radio, AFE, PLLs, and the ROMs are powered down. The rest of the BCM4330 remains powered up in an IDLE state. All main clocks are shut down. The 32.768 kHz LPO clock is available only for the PMU sequencer. This condition is necessary to allow the PMU sequencer to wake up the chip and transition to Active mode. In Doze mode, the primary power consumed is due to leakage current. The external switcher and internal baseband switcher are put into Burst mode (for better efficiency at low load currents).
- Power-down mode — The BCM4330 is effectively powered off by shutting down all internal regulators. The chip is brought out of this mode by external logic re-enabling the internal regulators.

Not Recommended for New Designs

PMU Sequencing

The PMU sequencer is responsible for minimizing system power consumption. It enables and disables various system resources based on a computation of the required resources and a table that describes the relationship between resources and the time needed to enable and disable them.

Resource requests may come from several sources: clock requests from cores, the minimum resources defined in the ResourceMin register, and the resources requested by any active resource request timers. The PMU sequencer maps clock requests into a set of resources required to produce the requested clocks.

Each resource is in one of four states: enabled, disabled, transition_on, and transition_off and has a timer that contains 0 when the resource is enabled or disabled and a non-zero value in the transition states. The timer is loaded with the resource's time_on or time_off value when the PMU determines that the resource must be enabled or disabled. That timer decrements on each 32.768 kHz PMU clock. When it reaches 0, the state changes from transition_off to disabled or transition_on to enabled. If the time_on value is 0, the resource can go immediately from disabled to enabled. Similarly, a time_off value of 0 indicates that the resource can go immediately from enabled to disabled. The terms enable sequence and disable sequence refer to either the immediate transition or the timer load-decrement sequence.

During each clock cycle, the PMU sequencer performs the following actions:

1. Computes the required resource set based on requests and the resource dependency table.
2. Decrements all timers whose values are non zero. If a timer reaches 0, the PMU clears the ResourcePending bit for the resource and inverts the ResourceState bit.
3. Compares the request with the current resource status and determines which resources must be enabled or disabled.
4. Initiates a disable sequence for each resource that is enabled, no longer being requested, and has no powered up dependents.
5. Initiates an enable sequence for each resource that is disabled, is being requested, and has all of its dependencies enabled.

Low-Power Shutdown

The BCM4330 provides a low-power shutdown feature that allows the device to be turned off while the host, and any other devices in the system, remain operational. When the BCM4330 is not needed in the system, VDDRF and VDDC are shut down while VDDO remains powered. This allows the BCM4330 to be effectively off while keeping the I/O pins powered so that they do not draw extra current from any other devices connected to the I/O.

During a low-power shut-down state, provided VDDO remains applied to the BCM4330, all outputs are tristated, and most inputs signals are disabled. Input voltages must remain within the limits defined for normal operation. This is done to prevent current paths or create loading on any digital signals in the system, and enables the BCM4330 to be fully integrated in an embedded device and take full advantage of the lowest power-savings modes.

Two signals on the BCM4330, the frequency reference input (WRF_XTAL_ON) and the LPO input, are designed to be high-impedance inputs that do not load down the driving signal even if the chip does not have VDDO power applied to it.

When the BCM4330 is powered on from this state, it is the same as a normal power-up and the device does not contain any information about its state from before it was powered down.

Reset Circuits

The BCM4330 has three signals (Table 1) that enable or disable the Bluetooth and WLAN circuits and the internal regulator blocks, allowing the host to control power consumption. For timing diagrams of these signals and the required power-up sequences, see Section 23: “Power-Up Sequence and Timing,” on page 158.

Table 1: Reset Control Signals

Signal	Description
WL_REG_ON	This signal is used by the PMU (with BT_REG_ON) to power up the WLAN section. It is also OR-gated with the BT_REG_ON input to control the internal BCM4330 regulators. When this pin is high, the regulators are enabled and the WLAN section is out of reset. When this pin is low, the WLAN section is in reset. If BT_REG_ON and WL_REG_ON are both low, the regulators are disabled. Logic High Level: 1.08V–3.6V. 200k pull-down resistor included.
BT_REG_ON	This signal is used by the PMU (with WL_REG_ON) to decide whether or not to power down the internal BCM4330 regulators. If BT_REG_ON and WL_REG_ON are low, the regulators will be disabled. Logic High Level: 1.08V–3.6V. 200k pull-down resistor included.
BT_RST_N	Low asserting reset for the Bluetooth core. This pin has no effect on WLAN and does not control any PMU functions. It must be driven high or low (not left floating).

In addition, two other input signals control PMU modes:

- When EXT_SMPS_REQ is pulled high, it forces CBUCK to stay on, even when the other regulators are shut down by WL_REG_ON or BT_REG_ON.
- When WLAN and/or Bluetooth are out of reset and EXT_SMPS_REQ is high, then pulling EXT_PWM_REQ high makes CBUCK go into PWM mode, even if internal settings from WLAN and/or Bluetooth are requesting burst mode. During such contention, the request for the higher-power mode wins.

Section 3: Frequency References

An external crystal is used for generating all radio frequencies and normal operation clocking. As an alternative, an external frequency reference driven by a temperature-compensated crystal oscillator (TCXO) signal may be used. In addition, a low-power oscillator (LPO) is provided for lower power mode timing.



Note: The crystal and TCXO implementations have different power supplies (WRF_XTAL_VDD1P2 for crystal, WRF_TCXO_VDD for TCXO).

Crystal Interface and Clock Generation

The BCM4330 can use an external crystal to provide a frequency reference. The recommended configuration for the crystal oscillator including all external components is shown in [Figure 5](#). Consult the reference schematics for the latest configuration.

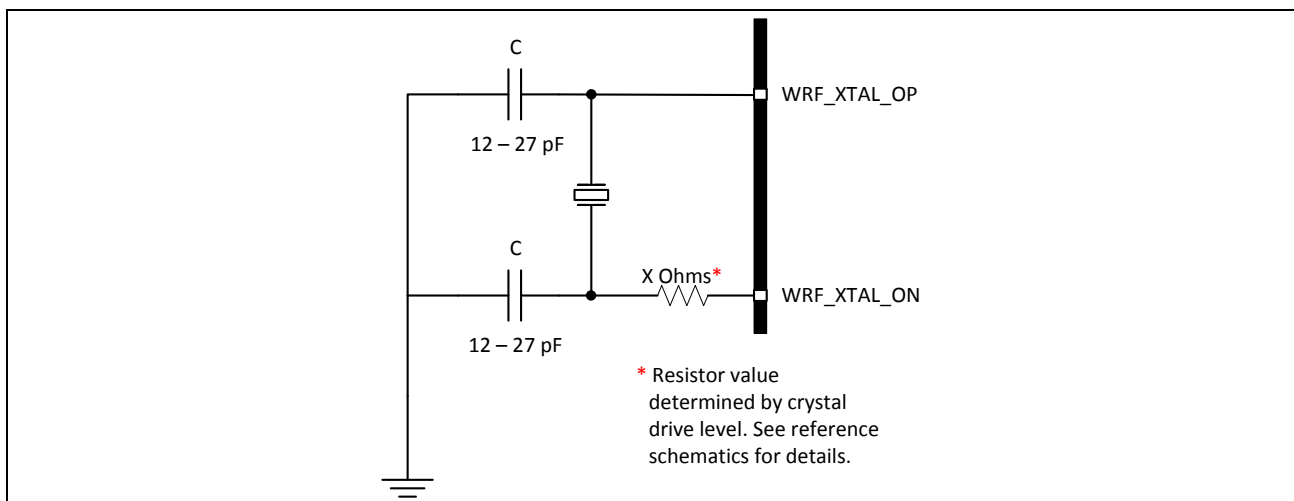

Figure 5: Recommended Oscillator Configuration

A fractional-N synthesizer in the BCM4330 generates the radio frequencies, clocks, and data/packet timing, enabling it to operate using a wide selection of frequency references.

For SDIO applications the default frequency reference is a 37.4 MHz crystal or TCXO. For HSIC applications, the recommended frequency reference is also 37.4 MHz. The signal characteristics for the crystal interface are listed in [Table 2 on page 34](#).



Note: The fractional-N synthesizer can support many reference frequencies. However, frequencies other than the default require support to be added in the driver plus additional, extensive system testing. Contact Broadcom for further details.

TCXO

As an alternative to a crystal, an external precision TCXO can be used as the frequency reference, provided that it meets the Phase Noise requirements listed in Table 2. When the clock is provided by an external TCXO, there are two possible connection methods, as shown in Figure 6 and Figure 7:

1. If the TCXO is dedicated to driving the BCM4330, it should be connected to the WRF_XTAL_OP pin through an external 1000 pF coupling capacitor, as shown in Figure 6. The internal clock buffer connected to this pin will be turned OFF when the BCM4330 goes into sleep mode. When the clock buffer turns ON and OFF there will be a small impedance variation. Power must be supplied to the WRF_XTAL_VDD1P2 pin.
2. For 2.4 GHz operation only, an alternative is to DC-couple the TCXO to the WRF_TCXO_IN pin, as shown in Figure 7. Use this method when the same TCXO is shared with other devices and a change in the input impedance is not acceptable because it may cause a frequency shift that cannot be tolerated by the other device sharing the TCXO. This pin is connected to a clock buffer powered from WRF_TCXO_VDD. If the power supply to this buffer is always on (even in sleep mode), the clock buffer is always on, thereby ensuring a constant input impedance in all states of the device. The maximum current drawn from WRF_TCXO_VDD is approximately 500 μ A.

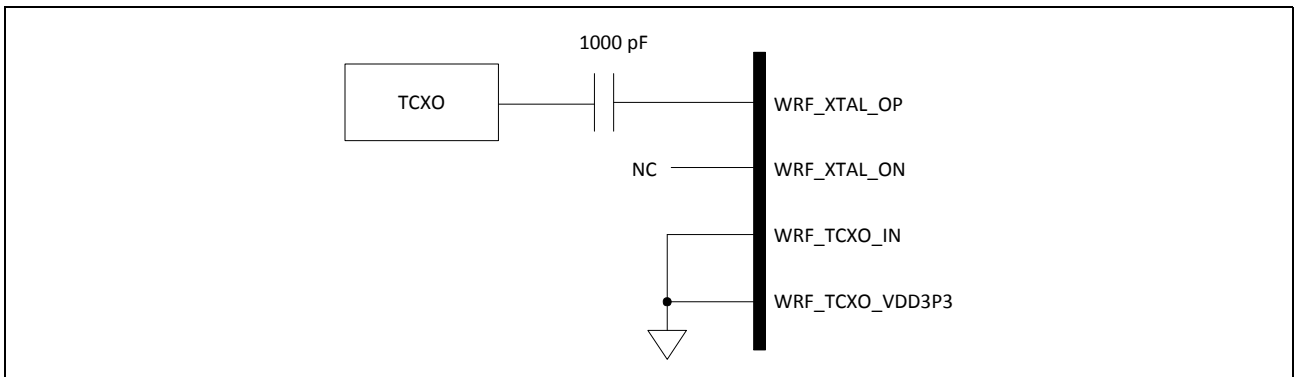

Figure 6: Recommended Circuit to Use with an External Dedicated TCXO

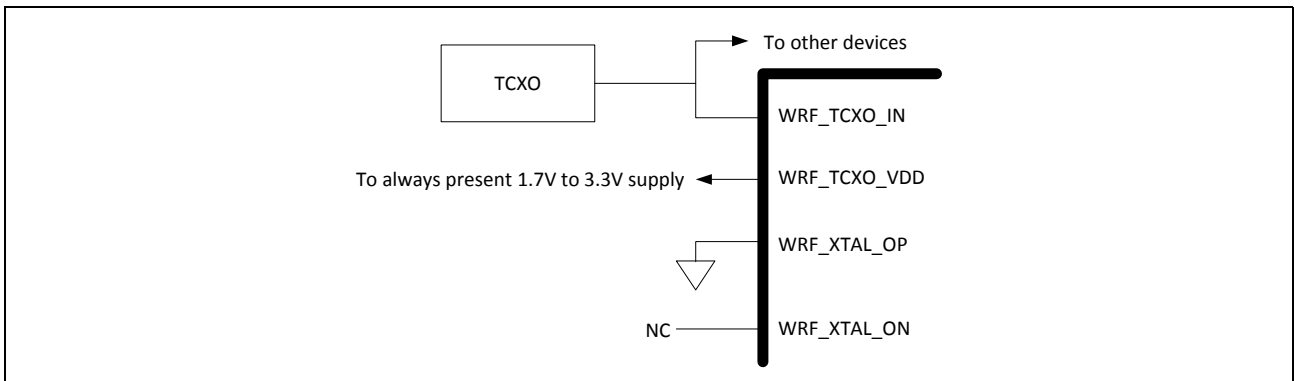

Figure 7: Recommended Circuit to Use with an External Shared TCXO

Not Recommended for New Designs

Table 2: Crystal Oscillator and External Clock – Requirements and Performance

Parameter	Conditions/Notes	Crystal ^a			External Frequency Reference ^{b,c}			Units
		Min	Typ	Max	Min	Typ	Max	
Frequency	–	Between 12 MHz and 52 MHz ^{d,e}						
Crystal load capacitance	–	–	12	–	–	–	–	pF
ESR	–	–	–	60	–	–	–	Ω
Drive level	External crystal	–	–	200	–	–	–	μW
Input impedance (WRF_XTAL_OP)	Resistive	30k	100k	–	30k	100k	–	Ω
	Capacitive	–	–	7.5	–	–	7.5	pF
Input impedance (WRF_TCXO_IN)	Resistive	–	–	–	30k	100k	–	Ω
	Capacitive	–	–	–	–	–	4	pF
WRF_XTAL_OP Input low level	DC-coupled digital signal	–	–	–	0	–	0.2	V
WRF_XTAL_OP Input high level	DC-coupled digital signal	–	–	–	1.0	–	1.36	V
WRF_XTAL_OP input voltage (see Figure 6 on page 33)	AC-coupled analog signal	–	–	–	400	–	1200	mV _{p-p}
WRF_TCXO_IN Input voltage (see Figure 7 on page 33)	DC-coupled analog signal	–	–	–	400	–	3300	mV _{p-p}
Frequency tolerance Initial + over temperature	Without trimming	–20	–	20	–20	–	20	ppm
Duty cycle	37.4 MHz clock	–	–	–	40	50	60	%
Phase Noise ^f (802.11b/g)	37.4 MHz clock at 1 kHz offset	–	–	–	–	–	–115	dBc/Hz
	37.4 MHz clock at 10 kHz offset	–	–	–	–	–	–125	dBc/Hz
	37.4 MHz clock at 100 kHz offset	–	–	–	–	–	–130	dBc/Hz
	37.4 MHz clock at 1 MHz offset	–	–	–	–	–	–135	dBc/Hz
Phase Noise ^f (802.11a)	37.4 MHz clock at 1 kHz offset	–	–	–	–	–	–123	dBc/Hz
	37.4 MHz clock at 10 kHz offset	–	–	–	–	–	–133	dBc/Hz
	37.4 MHz clock at 100 kHz offset	–	–	–	–	–	–138	dBc/Hz
	37.4 MHz clock at 1 MHz offset	–	–	–	–	–	–143	dBc/Hz
Phase Noise ^f (802.11n, 2.4 GHz)	37.4 MHz clock at 1 kHz offset	–	–	–	–	–	–120	dBc/Hz
	37.4 MHz clock at 10 kHz offset	–	–	–	–	–	–130	dBc/Hz
	37.4 MHz clock at 100 kHz offset	–	–	–	–	–	–135	dBc/Hz
	37.4 MHz clock at 1 MHz offset	–	–	–	–	–	–140	dBc/Hz

Not Recommended for New Designs

Table 2: Crystal Oscillator and External Clock – Requirements and Performance (Cont.)

Parameter	Conditions/Notes	Crystal ^a			External Frequency Reference ^{b c}			Units
		Min	Typ	Max	Min	Typ	Max	
Phase Noise ^f (802.11n, 5 GHz)	37.4 MHz clock at 1 kHz offset	–	–	–	–	–	–128	dBc/Hz
	37.4 MHz clock at 10 kHz offset	–	–	–	–	–	–138	dBc/Hz
	37.4 MHz clock at 100 kHz offset	–	–	–	–	–	–143	dBc/Hz
	37.4 MHz clock at 1 MHz offset	–	–	–	–	–	–148	dBc/Hz

- (Crystal) Use WRF_XTAL_OP and WRF_XTAL_ON, internal power to pin WRF_XTAL_VDD1P2.
- (TCXO) See “TCXO” on page 33 for alternative connection methods.
- For a clock reference other than 37.4 MHz, $20 \times \log_{10}(f/37.4)$ dB should be added to the limits, where f = the reference clock frequency in MHz.
- BT_TM6 should be tied low for a 52 MHz clock reference. For other frequencies, BT_TM6 should be tied high. Note that 52 MHz is not an auto-detected frequency using the LPO clock.
- The frequency step size is approximately 80 Hz resolution.
- If the selected clock has a flat phase noise response above 100 kHz, that is, the phase noise at and above 100 kHz is constant, then subtract 1dB from all 1 kHz, 10 kHz, and 100 kHz values shown. For example, for the 2.4 GHz 802.11b/g values, the phase noise requirements change from –115, –125, and –130 dBc/Hz to –116, –126, and –131 dBc/Hz respectively. Ignore the 1 MHz requirements when the phase noise is flat above 100 kHz.

Frequency Selection

Any frequency within the ranges specified for the crystal and TCXO reference may be used. These include not only the standard handset reference frequencies of 12, 13, 14.4, 16.2, 16.8, 19.2, 19.44, 19.68, 19.8, 20, 26, 37.4, and 52 MHz, but also other frequencies in this range, with approximately 80 Hz resolution. The BCM4330 must have the reference frequency set correctly in order for any of the UART or PCM interfaces to function correctly, since all bit timing is derived from the reference frequency.



Note: The fractional-N synthesizer can support many reference frequencies. However, frequencies other than the default require support to be added in the driver plus additional, extensive system testing. Contact Broadcom for further details.

The reference frequency for the BCM4330 may be set in the following ways:

- Set the “xtalfreq=xxxxx” parameter in the nvram.txt file (used to load the driver) to correctly match the crystal frequency.
- Auto-detect any of the standard handset reference frequencies using an external LPO clock.

For applications such as handsets and portable smart communication devices, where the reference frequency is one of the standard frequencies commonly used, the BCM4330 automatically detects the reference frequency and programs itself to the correct reference frequency. In order for auto frequency detection to work correctly, the BCM4330 must have a valid and stable 32.768 kHz LPO clock that meets the requirements listed in [Table 3 on page 37](#) and is present during power-on reset.

External 32.768 kHz Low Power Oscillator

The BCM4330 uses a secondary low frequency clock for low power mode timing.

A precision external 32.768 kHz clock that meets the specifications listed in [Table 3](#) is required by the BCM4330.

Table 3: External 32.768 kHz Sleep Clock Specifications

Parameter	LPO Clock	Units
Nominal input frequency	32.768	kHz
Frequency accuracy	$\pm 200^{\text{a, b}}$	ppm
Duty cycle	30–70	%
Input signal amplitude	200–1800 ^c	mV, p-p
Signal type	Square-wave or sine-wave	–
Input impedance ^d	>100k <5	Ω pF
Clock jitter (integrated over 300 Hz–15 kHz)	<5	ns
Clock jitter (during initial start-up)	<10,000	ppm

- If FM RX is used: ± 150 ppm maximum with frequency error indication, ± 50 ppm without frequency error indication.
- If FM TX is used: ± 100 ppm maximum with frequency error indication, ± 50 ppm without frequency error indication.
- 200–1800 mVp-p to avoid additional current consumption and degradation in FM SNR. 3.3 Vp-p maximum.
- When power is applied or switched off.

Not Recommended for New Designs

Section 4: Bluetooth + FM Subsystem Overview

The Broadcom BCM4330 is a Bluetooth 4.0 + EDR-compliant, baseband processor/ 2.4 GHz transceiver with an integrated FM/ RDS/RBDS receiver and FM/RDS transmitter. It features the highest level of integration and eliminates all critical external components, thus minimizing the footprint, power consumption, and system cost of a Bluetooth plus FM radio solution.

The BCM4330 is the optimal solution for any Bluetooth voice and/or data application that also requires an FM radio receiver and transmitter. The Bluetooth subsystem presents a standard Host Controller Interface (HCI) via a high speed UART and PCM for audio. The FM subsystem supports the HCI control interface, analog input and output, as well as I²S and PCM interfaces. The BCM4330 incorporates all Bluetooth 4.0 features including Secure Simple Pairing, Sniff Subrating, and Encryption Pause and Resume.

The BCM4330 Bluetooth radio transceiver provides enhanced radio performance to meet the most stringent mobile phone temperature applications and the tightest integration into mobile handsets and portable devices. It is fully compatible with any of the standard TCXO frequencies and provides full radio compatibility to operate simultaneously with GPS, WLAN, and cellular radios.

The Bluetooth transmitter also features a Class 1 power amplifier with Class 2 capability.

Features

Major Bluetooth features of the BCM4330 include:

- Supports key features of upcoming Bluetooth standards
- Fully supports Bluetooth Core Specification version 4.0 + (Enhanced Data Rate) EDR features:
 - Adaptive Frequency Hopping (AFH)
 - Quality of Service (QoS)
 - Extended Synchronous Connections (eSCO) — Voice Connections
 - Fast Connect (interlaced page and inquiry scans)
 - Secure Simple Pairing (SSP)
 - Sniff Subrating (SSR)
 - Encryption Pause Resume (EPR)
 - Extended Inquiry Response (EIR)
 - Link Supervision Timeout (LST)
- UART baud rates up to 4 Mbps
- Supports all Bluetooth 4.0 + HS packet types
- Supports maximum Bluetooth data rates over HCI UART
- Multipoint operation with up to seven active slaves
 - Maximum of seven simultaneous active ACL links
 - Maximum of three simultaneous active SCO and eSCO connections with scatternet support

- Narrowband and wideband packet loss concealment
- Scatternet operation with up to four active piconets with background scan and support for scatter mode
- High-speed HCI UART transport support with low-power out-of-band BT_WAKE and HOST_WAKE signaling (see “Host Controller Power Management” on page 45)
- Channel quality driven data rate and packet type selection
- Standard Bluetooth test modes
- Extended radio and production test mode features
- Full support for power savings modes
 - Bluetooth clock request
 - Bluetooth standard sniff
 - Deep-sleep modes and software regulator shutdown
- TCXO input and auto-detection of all standard handset clock frequencies. Also supports a low-power crystal, which can be used during power save mode for better timing accuracy.

Major FM Radio features include:

- 65 MHz to 108 MHz FM bands supported (US, Europe, and Japan)
- FM subsystem control using the Bluetooth HCI interface
- FM subsystem operates from 32.768 kHz low-power oscillator (LPO) or reference clock inputs
- Improved audio interface capabilities with full-featured bidirectional PCM, I²S, and analog stereo DAC
- I²S can be master or slave

FM Receiver-Specific Features Include:

- Excellent FM radio performance with 1 μ V sensitivity for 26 dB (S+N)/N
- Signal-dependent stereo/mono blending
- Signal dependent soft mute
- Auto search and tuning modes
- Audio silence detection
- RSSI, IF frequency, status indicators
- RDS and RBDS demodulator and decoder with filter and buffering functions
- Automatic frequency jump

FM Transmitter-Specific Features Include:

- Programmable output power with +120 dB μ V maximum output power and 24 dB range
- RDS and RBDS encoder and modulator with intelligent frame encoding and programmable scroll rate
- Programmable audio swing to FM modulation deviation
- Programmable mono or stereo transmission
- Concurrent Bluetooth v4.0 + EDR and FM transmit functionality
- Digital audio input from I²S or PCM
- Host programmable frequency from 76 MHz to 108 MHz in 50 kHz channel steps
- Digitally programmable audio level and mute control

Bluetooth Radio

The BCM4330 has an integrated radio transceiver that has been optimized for use in 2.4 GHz Bluetooth wireless systems. It has been designed to provide low-power, low-cost, robust communications for applications operating in the globally available 2.4 GHz unlicensed ISM band. It is fully compliant with the Bluetooth Radio Specification and EDR specification and meets or exceeds the requirements to provide the highest communication link quality of service.

Transmit

The BCM4330 features a fully integrated zero-IF transmitter. The baseband transmit data is GFSK-modulated in the modem block and upconverted to the 2.4 GHz ISM band in the transmitter path. The transmitter path consists of signal filtering, I/Q upconversion, output power amplifier, and RF filtering. The transmitter path also incorporates $\pi/4$ -DQPSK for 2 Mbps and 8-DPSK for 3 Mbps to support EDR. The transmitter section is compatible to the Bluetooth Low Energy specification. The transmitter PA bias can also be adjusted to provide Bluetooth Class 1 operation.

Digital Modulator

The digital modulator performs the data modulation and filtering required for the GFSK, $\pi/4$ -DQPSK, and 8-DPSK signal. The fully digital modulator minimizes any frequency drift or anomalies in the modulation characteristics of the transmitted signal and is much more stable than direct VCO modulation schemes.

Digital Demodulator and Bit Synchronizer

The digital demodulator and bit synchronizer take the low-IF received signal and perform an optimal frequency tracking and bit-synchronization algorithm.

Power Amplifier

The fully integrated PA supports Class 1 or Class 2 output using a highly linearized, temperature-compensated design. This provides greater flexibility in front-end matching and filtering. The fully integrated PA supports Class 1 and Class 2 output using a temperature-compensated, auto-transformer-based design. This provides a simplified front end that does not require off-chip components for matching and better efficiency. External filtering is required for meeting Bluetooth and regulatory harmonic and spurious requirements. For integrated mobile handset applications where the Bluetooth is integrated next to the cellular radio, minimal external filtering can be applied to achieve near thermal noise levels for spurious and radiated noise emissions. The transmitter features a sophisticated on-chip transmit signal strength indicator (TSSI) block to keep the absolute output power variation within a tight range across process, voltage, and temperature.

Receiver

The receiver path uses a low-IF scheme to downconvert the received signal for demodulation in the digital demodulator and bit synchronizer. The receiver path provides a high degree of linearity, an extended dynamic range, and high-order on-chip channel filtering to ensure reliable operation in the noisy 2.4 GHz ISM band. The front-end topology with built-in out-of-band attenuation enables the BCM4330 to be used in most applications with no off-chip filtering. For integrated handset operation, where the Bluetooth function is integrated close to the cellular transmitter, minimal external filtering is required to eliminate the desensitization of the receiver by the cellular transmit signal.

Digital Demodulator and Bit Synchronizer

The digital demodulator and bit synchronizer take the low-IF received signal and perform an optimal frequency tracking and bit synchronization algorithm.

Receiver Signal Strength Indicator

The radio portion of the BCM4330 provides a Receiver Signal Strength Indicator (RSSI) signal to the baseband, so that the controller can take part in a Bluetooth power-controlled link by providing a metric of its own receiver signal strength to determine whether the transmitter should increase or decrease its output power.

Local Oscillator Generation

Local Oscillator (LO) generation provides fast frequency hopping (1600 hops/second) across the 79 maximum available channels. The LO generation subblock employs an architecture for high immunity to LO pulling during PA operation. The BCM4330 uses an internal RF and IF loop filter.

Calibration

The BCM4330 radio transceiver features an automated calibration scheme that is fully self contained in the radio. No user interaction is required during normal operation or during manufacturing to provide the optimal performance. Calibration optimizes the performance of all the major blocks within the radio to optimal conditions, including gain and phase characteristics of filters, matching between key components, and key gain blocks. This takes into account process variation and temperature variation. Calibration occurs transparently during normal operation during the settling time of the hops and calibrates for temperature variations as the device cools and heats during normal operation in its environment.

Section 5: Bluetooth Baseband Core

The Bluetooth Baseband Core (BBC) implements all of the time critical functions required for high-performance Bluetooth operation. The BBC manages the buffering, segmentation, and routing of data for all connections. It also buffers data that passes through it, handles data flow control, schedules SCO/ACL TX/RX transactions, monitors Bluetooth slot usage, optimally segments and packages data into baseband packets, manages connection status indicators, and composes and decodes HCI packets. In addition to these functions, it independently handles HCI event types, and HCI command types.

The following transmit and receive functions are also implemented in the BBC hardware to increase reliability and security of the TX/RX data before sending over the air:

- Symbol timing recovery, data deframing, forward error correction (FEC), header error control (HEC), cyclic redundancy check (CRC), data decryption, and data dewatering in the receiver.
- Data framing, FEC generation, HEC generation, CRC generation, key generation, data encryption, and data whitening in the transmitter.

Bluetooth 4.0 Features

The BBC supports Bluetooth 4.0 features with the following benefits:

- Dual mode Bluetooth Low Energy (BT and BLE operation).
- Extended Inquiry Response (EIR): Shortens the time to retrieve the device name, specific profile, and operating mode.
- Encryption Pause Resume (EPR): Enables the use of Bluetooth technology in a much more secure environment.
- Sniff Subrating (SSR): Optimizes power consumption for low duty cycle asymmetrical data flow, which subsequently extends battery lifetime.
- Secure Simple Pairing (SSP): Reduces the number of steps for connecting two devices with minimal or no user interaction required.
- Link Supervision Time Out (LSTO): Additional commands added to HCI and Link Management Protocol (LMP) for improved link time-out supervision.
- QoS Enhancements: Changes to data traffic control, which results in better link performance. Audio, human interface design (HID), bulk traffic, SCO and enhanced SCO (eSCO) are improved with the erroneous data (ED) and packet boundary flag (PBF) enhancements.

Bluetooth Low Energy

The BCM4330 is forward-compatible with the impending Bluetooth Low Energy operating mode, which provides a dramatic reduction in the power consumption of the Bluetooth radio and baseband. The primary application for this mode is to provide support for low data rate devices, such as sensors and remote controls.

Link Control Layer

The link control layer is part of the Bluetooth link control functions that are implemented in dedicated logic in the link control unit (LCU). This layer consists of the command controller that takes commands from the software, and other controllers that are activated or configured by the command controller, to perform the link control tasks. Each task performs a different state in the Bluetooth Link Controller.

- Major states:
 - Standby
 - Connection
- Substates:
 - Page
 - Page Scan
 - Inquiry
 - Inquiry Scan
 - Sniff

Test Mode Support

The BCM4330 fully supports Bluetooth Test mode as described in Part I:1 of the *Specification of the Bluetooth System Version 3.0*. This includes the transmitter tests, normal and delayed loopback tests, and reduced hopping sequence.

In addition to the standard Bluetooth Test Mode, the BCM4330 also supports enhanced testing features to simplify RF debugging and qualification and type-approval testing. These features include:

- Fixed frequency carrier wave (unmodulated) transmission
 - Simplifies some type-approval measurements (Japan)
 - Aids in transmitter performance analysis
- Fixed frequency constant receiver mode
 - Receiver output directed to I/O pin
 - Allows for direct BER measurements using standard RF test equipment
 - Facilitates spurious emissions testing for receive mode
- Fixed frequency constant transmission
 - Eight-bit fixed pattern or PRBS-9
 - Enables modulated signal measurements with standard RF test equipment

Bluetooth Power Management Unit

The Bluetooth Power Management Unit (PMU) provides power management features that can be invoked by either software through power management registers or packet handling in the baseband core. The power management functions provided by the BCM4330 are:

- [RF Power Management](#)
- [Host Controller Power Management](#)
- [BBC Power Management](#)
- [FM Power Management](#)

RF Power Management

The BBC generates power-down control signals for the transmit path, receive path, PLL, and power amplifier to the 2.4 GHz transceiver. The transceiver then processes the power-down functions accordingly.

Not Recommended for New Designs

Host Controller Power Management

When running in UART mode, the BCM4330 may be configured so that dedicated signals are used for power management hand-shaking between the BCM4330 and the host. The basic power saving functions supported by those hand-shaking signals include the standard Bluetooth defined power savings modes and standby modes of operation.

Table 4 describes the power-control hand-shake signals used with the UART interface.

Table 4: Power Control Pin Description

Signal	Mapped to Pin	Type	Description
BT_WAKE	BT_GPIO_0	I	Bluetooth device wake-up: Signal from the host to the BCM4330 indicating that the host requires attention. <ul style="list-style-type: none"> Asserted: Bluetooth device must wake-up or remain awake. Deasserted: Bluetooth device may sleep when sleep criteria are met. The polarity of this signal is software configurable and can be asserted high or low.
HOST_WAKE	BT_GPIO_1	O	Host wake up. Signal from the BCM4330 to the host indicating that the BCM4330 requires attention. <ul style="list-style-type: none"> Asserted: host device must wake-up or remain awake. Deasserted: host device may sleep when sleep criteria are met. The polarity of this signal is software configurable and can be asserted high or low.
BT_CLK_REQ_OUT	BT_CLK_REQ_OUT	O	The BCM4330 asserts CLK_REQ when Bluetooth or WLAN wants the host to turn on the reference clock. The CLK_REQ polarity is active-high. Add an external 100 kΩ pull-down resistor to ensure the signal is deasserted when the BCM4330 powers up or resets when VDDIO is present.

Note: Pad function Control Register is set to 0 for these pins. See [“Muxed Bluetooth GPIO Signals” on page 113](#) for details.



Note: Successful operation of the power management hand-shaking signals requires coordination between the BCM4330 firmware and the host software (see [Figure 8 on page 46](#)).

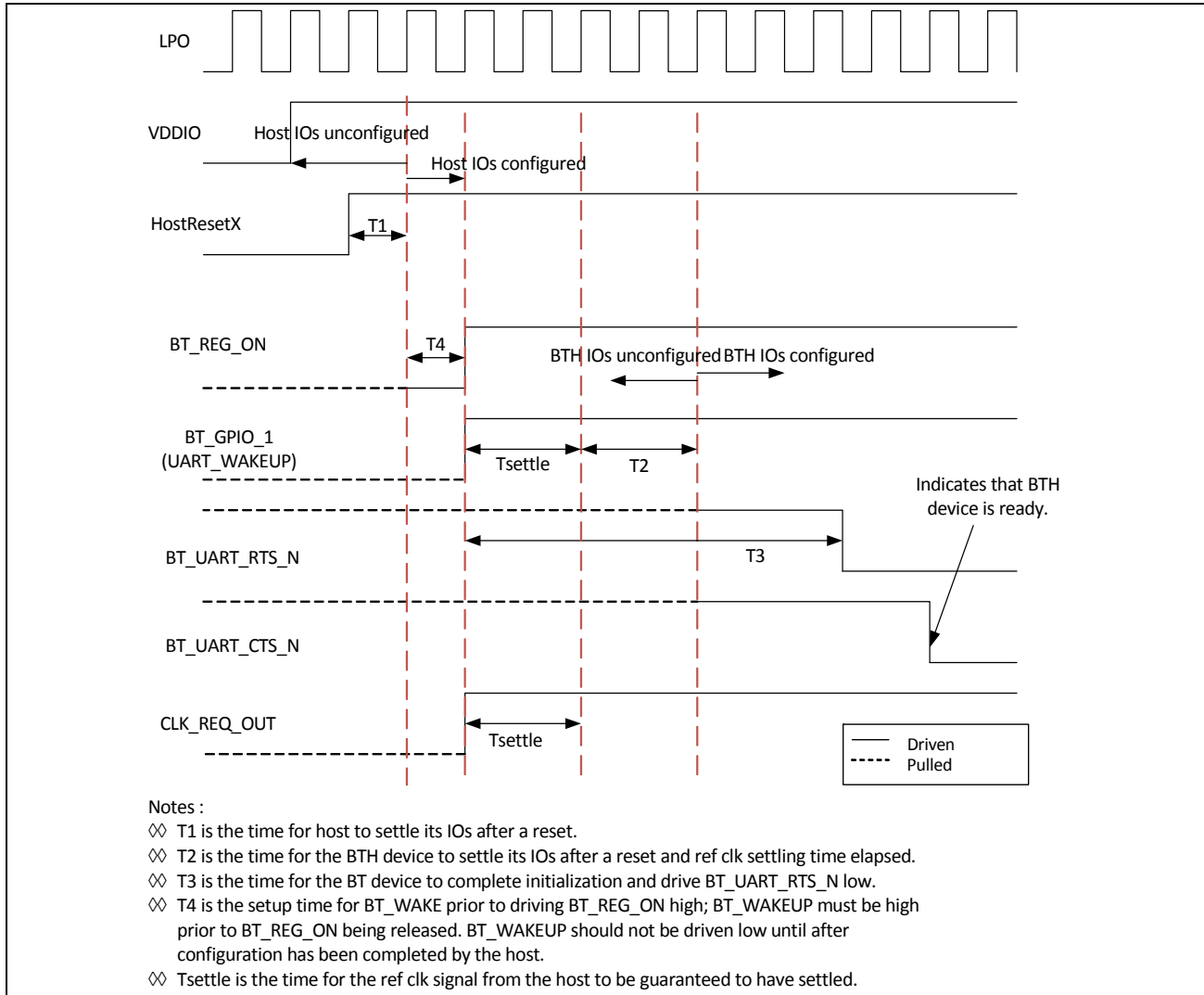

Figure 8: Startup Signaling Sequence

Not Recommended for New Designs

BBC Power Management

The following are low-power operations for the BBC:

- Physical layer packet-handling turns the RF on and off dynamically within transmit/receive packets.
- Bluetooth-specified low-power connection modes: sniff, hold, and park. While in these modes, the BCM4330 runs on the low-power oscillator and wakes up after a predefined time period.
- A low-power shutdown feature allows the device to be turned off while the host and any other devices in the system remain operational. When the BCM4330 is not needed in the system, the RF and core supplies are shut down while the I/O remains powered. This allows the BCM4330 to effectively be off while keeping the I/O pins powered so they do not draw extra current from any other devices connected to the I/O.

During the low-power shut-down state, provided VDDIO remains applied to the BCM4330, all outputs are tri-stated, and most input signals are disabled. Input voltages must remain within the limits defined for normal operation. This is done to prevent current paths or create loading on any digital signals in the system and enables the BCM4330 to be fully integrated in an embedded device to take full advantage of the lowest power-saving modes.

Two BCM4330 input signals are designed to be high-impedance inputs that do not load the driving signal even if the chip does not have VDDIO power supplied to it: the frequency reference input (WRF_TCXO_IN) and the 32.768 kHz input (LPO). When the BCM4330 is powered on from this state, it is the same as a normal power-up, and the device does not contain any information about its state from the time before it was powered down.

FM Power Management

The BCM4330 FM subsystem can operate independently of, or in tandem with, the Bluetooth RF and BBC subsystems. The FM subsystem power management scheme operates in conjunction with the Bluetooth RF and BBC subsystems. The FM block does not have a low power state, it is either on or off.

Low-Power Scan

The BCM4330 has an optional low-power scan mode that replaces conventional page/inquiry scans with a proprietary scan scheme. When this mode is activated, it significantly reduces current consumption for page and inquiry scans. The mode will switch to conventional scans if energy in page/inquiry channels with an appropriate activation pattern is detected.

Wideband Speech

The BCM4330 provides support for wideband speech (WBS) using on-chip Smart Audio technology. The BCM4330 can perform subband-codec (SBC), as well as mSBC, encoding and decoding of linear 16 bits at 16 kHz (256 Kbps rate) transferred over the PCM bus.

Packet Loss Concealment

Packet Loss Concealment (PLC) improves apparent audio quality for systems with marginal link performance. Bluetooth messages are sent in packets. When a packet is lost, it creates a gap in the received audio bit-stream. Packet loss can be mitigated in several ways:

- Fill in zeros.
- Ramp down the output audio signal toward zero (this is the method used in current Bluetooth headsets).
- Repeat the last frame (or packet) of the received bit-stream and decode it as usual (frame repeat).

These techniques cause distortion and popping in the audio stream. The BCM4330 uses a proprietary waveform extension algorithm to provide dramatic improvement in the audio quality. [Figure 9](#) and [Figure 10](#) show audio waveforms with and without Packet Loss Concealment. Broadcom PLC/BEC algorithms also support wide band speech.

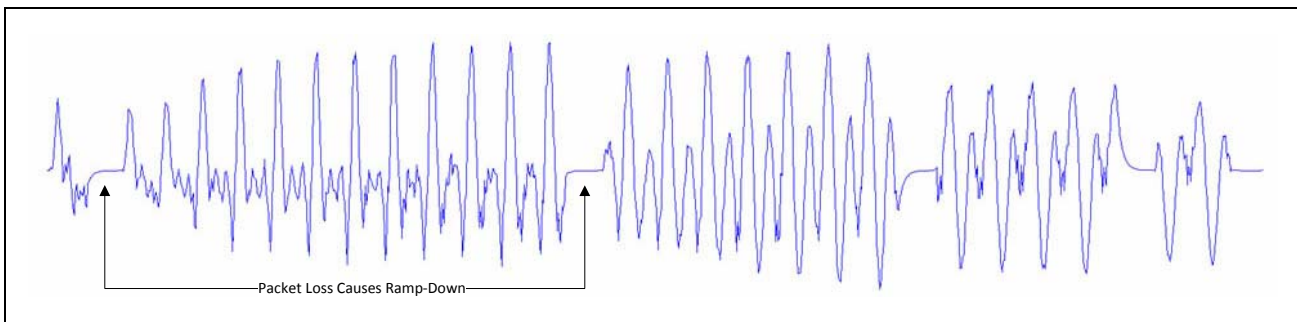

Figure 9: CVSD Decoder Output Waveform Without PLC

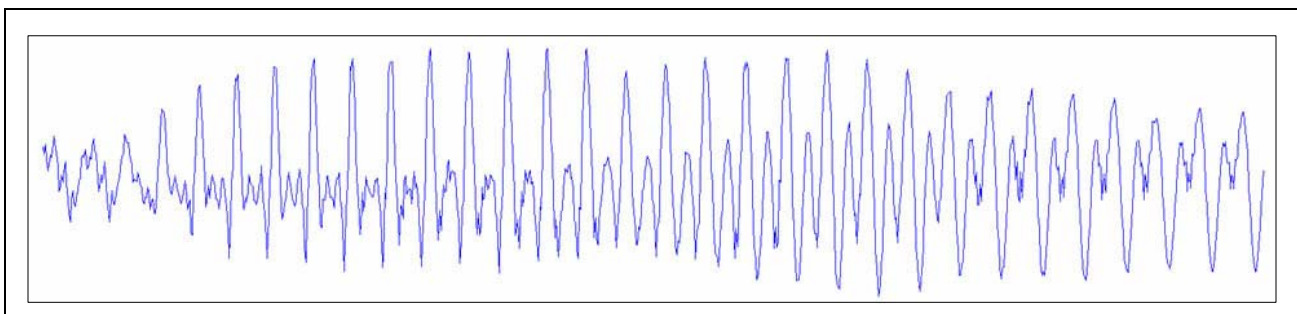

Figure 10: CVSD Decoder Output Waveform After Applying PLC

Audio Rate-Matching Algorithms

The BCM4330 has an enhanced rate-matching algorithm that uses interpolation algorithms to reduce audio stream jitter that may be present when the rate of audio data coming from the host is not the same as the Bluetooth or FM audio data rates.

Codec Encoding

The BCM4330 can support SBC and mSBC encoding and decoding for wideband speech.

Multiple Simultaneous A2DP Audio Stream

The BCM4330 has the ability to take a single audio stream and output it to multiple Bluetooth devices simultaneously. This allows a user to share his or her music (or any audio stream) with a friend.

FM Over Bluetooth

FM Over Bluetooth enables the BCM4330 to stream data from FM over Bluetooth without requiring the host to be awake. This can significantly extend battery life for usage cases where someone is listening to FM radio on a Bluetooth headset.

Burst Buffer Operation

The BCM4330 has a data buffer that can buffer data being sent over the HCI and audio transports, then send the data at an increased rate. This mode of operation allows the host to sleep for the maximum amount of time, dramatically reducing system current consumption.

Adaptive Frequency Hopping

The BCM4330 gathers link quality statistics on a channel by channel basis to facilitate channel assessment and channel map selection. The link quality is determined using both RF and baseband signal processing to provide a more accurate frequency-hop map.

Advanced Bluetooth/WLAN Coexistence

The BCM4330 includes advanced coexistence technologies that are only possible with a Bluetooth/WLAN integrated die solution. These coexistence technologies are targeted at small form-factor platforms, such as cell phones and media players, including applications such as VoWLAN + SCO and Video-over-WLAN + High Fidelity BT Stereo.

Support is provided for platforms that share a single antenna between Bluetooth and 802.11g. Dual-antenna applications are also supported. The BCM4330 radio architecture allows for lossless simultaneous Bluetooth and WLAN reception for shared antenna applications. This is possible only via an integrated solution (shared LNA and joint AGC algorithm). It has superior performance versus implementations that need to arbitrate between Bluetooth and WLAN reception.

The BCM4330 integrated solution enables MAC-layer signaling (firmware) and a greater degree of sharing via an enhanced coexistence interface. Information is exchanged between the Bluetooth and WLAN cores without host processor involvement.

The BCM4330 also supports Transmit Power Control on the STA together with standard Bluetooth TPC to limit mutual interference and receiver desensitization. Preemption mechanisms are utilized to prevent AP transmissions from colliding with Bluetooth frames. Improved channel classification techniques have been implemented in Bluetooth for faster and more accurate detection and elimination of interferers (including non-WLAN 2.4 GHz interference).

The Bluetooth AFH classification is also enhanced by the WLAN core's channel information.

Fast Connection (Interlaced Page and Inquiry Scans)

The BCM4330 supports page scan and inquiry scan modes that significantly reduce the average inquiry response and connection times. These scanning modes are compatible with the Bluetooth version 2.1 page and inquiry procedures.

Not Recommended for New Designs

Section 6: Music and Audio

The BCM4330 provides superior total system current during music or audio playback and recording. To enable these functions, several features of the device are combined to provide superior system power consumption.

MP3 Encoder

- ISO/IEC 11172-3 compliant
- Supports 32 kHz sampling frequencies only
- Encodes mono and stereo signals

MP3 Decoder

The MP3 decoder supports mono and stereo audio recording with the following specifications:

- Supports MPEG-1 Layer 3 decoding
- Output is fully bit compliant with MPEG-1 standard specification
- Supports sampling frequencies from 32 kHz to 48 kHz
- Minimum bit-rate supported 32 Kbps and maximum bit-rate supported 320 Kbps for Layer 3

AAC/AAC+ Decoder

Compliant to ISO/IEC 14496-3: 2004 specifications:

- MPEG-2, MPEG-4 AAC LC decoding up to level 2
- SBR tool, up to level 3
- Low power SBR tool
- Full support up to level 3 for the HE AAC profile
- Implicit and explicit SBR signaling mechanisms
- Mono and stereo channel streams decoding sampling frequencies from 8 kHz to 96 kHz only
- ADTS frame decoding

Section 7: Microprocessor and Memory Unit for Bluetooth

The Bluetooth microprocessor core is based on the ARM® Cortex™-M3 32-bit RISC processor with embedded ICE-RT debug and JTAG interface units. It runs software from the link control (LC) layer, up to the host controller interface (HCI).

The ARM core is paired with a memory unit that contains 560 KB of ROM memory for program storage and boot ROM, 152 KB of RAM for data scratchpad and patch RAM code. The internal ROM allows for flexibility during power-on reset to enable the same device to be used in various configurations. At power-up, the lower-layer protocol stack is executed from the internal ROM memory.

External patches may be applied to the ROM-based firmware to provide flexibility for bug fixes or features additions. These patches may be downloaded from the host to the BCM4330 through the UART transports. The mechanism for downloading via UART is identical to the proven interface of the BCM4329 device.

RAM, ROM, and Patch Memory

The BCM4330 Bluetooth core has 152 KB of internal RAM which is mapped between general purpose scratch pad memory and patch memory and 560 KB of ROM used for the lower-layer protocol stack, test mode software, and boot ROM. The patch memory capability enables the addition of code changes for purposes of feature additions and bug fixes to the ROM memory.

Reset

The BCM4330 has an integrated power-on reset circuit that resets all circuits to a known power-on state. The reset can also be driven by an active-low, external reset signal, BT_RST_N, that can be used to externally control the device, forcing it into a power-on reset state. (Note that the BT_RST_N signal is independent of the POR reset.)

Section 8: Bluetooth Peripheral Transport Unit

PCM Interface

The BCM4330 supports two independent PCM interfaces that share the pins with the I²S interfaces. The PCM Interface on the BCM4330 can connect to linear PCM Codec devices in master or slave mode. In master mode, the BCM4330 generates the PCM_CLK and PCM_SYNC signals, and in slave mode, these signals are provided by another master on the PCM interface and are inputs to the BCM4330.

The configuration of the PCM interface may be adjusted by the host through the use of vendor-specific HCI commands.

Slot Mapping

The BCM4330 supports up to three simultaneous full-duplex SCO or eSCO channels through the PCM interface. These three channels are time-multiplexed onto the single PCM interface by using a time-slotting scheme where the 8 kHz or 16 kHz audio sample interval is divided into as many as 16 slots. The number of slots is dependent on the selected interface rate of 128 kHz, 512 kHz, or 1024 kHz. The corresponding number of slots for these interface rate is 1, 2, 4, 8, and 16, respectively. Transmit and receive PCM data from an SCO channel is always mapped to the same slot. The PCM data output driver tri-states its output on unused slots to allow other devices to share the same PCM interface signals. The data output driver tri-states its output after the falling edge of the PCM clock during the last bit of the slot.

Frame Synchronization

The BCM4330 supports both short- and long-frame synchronization in both master and slave modes. In short-frame synchronization mode, the frame synchronization signal is an active-high pulse at the audio frame rate that is a single-bit period in width and is synchronized to the rising edge of the bit clock. The PCM slave looks for a high on the falling edge of the bit clock and expects the first bit of the first slot to start at the next rising edge of the clock. In long-frame synchronization mode, the frame synchronization signal is again an active-high pulse at the audio frame rate; however, the duration is three bit periods and the pulse starts coincident with the first bit of the first slot.

Data Formatting

The BCM4330 may be configured to generate and accept several different data formats. For conventional narrowband speech mode, the BCM4330 uses 13 of the 16 bits in each PCM frame. The location and order of these 13 bits can be configured to support various data formats on the PCM interface. The remaining three bits are ignored on the input and may be filled with 0s, 1s, a sign bit, or a programmed value on the output. The default format is 13-bit 2's complement data, left justified, and clocked MSB first.

Wideband Speech Support

When the host encodes Wideband Speech (WBS) packets in transparent mode, the encoded packets are transferred over the PCM bus for an eSCO voice connection. In this mode, the PCM bus is typically configured in master mode for a 4 kHz sync rate with 16-bit samples, resulting in a 64 Kbps bit rate. The BCM4330 also supports slave transparent mode using a proprietary rate-matching scheme. In SBC-code mode, linear 16-bit data at 16 kHz (256 Kbps rate) is transferred over the PCM bus.

Multiplexed Bluetooth and FM Over PCM

In this mode of operation, the BCM4330 multiplexes both FM and Bluetooth audio PCM channels over the same interface, reducing the number of required I/Os. This mode of operation is initiated through an HCI command from the host. The format of the data stream consists of three channels: a Bluetooth channel followed by two FM channels (audio left and right). In this mode of operation, the bus data rate only supports 48 kHz operation per channel with 16 bits sent for each channel. This is done to allow the low data rate Bluetooth data to coexist in the same interface as the higher speed I²S data. To accomplish this, the Bluetooth data is repeated six times for 8 kHz data and three times for 16 kHz data. An initial sync pulse on the PCM_SYNC line is used to indicate the beginning of the frame.

To support multiple Bluetooth audio streams within the Bluetooth channel, both 16 kHz and 8 kHz streams can be multiplexed. This mode of operation is only supported when the Bluetooth host is the master. Figure 11 shows the operation of the multiplexed transport with three simultaneous SCO connections. To accommodate additional SCO channels, the transport clock speed is increased. To change between modes of operation, the transport must be halted and restarted in the new configuration.

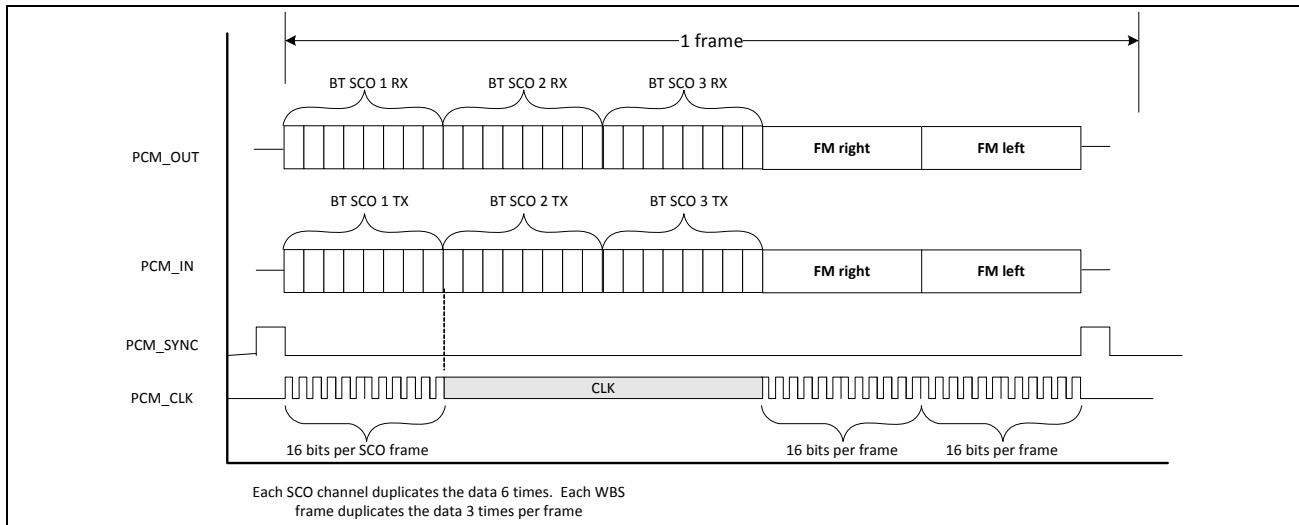

Figure 11: Functional Multiplex Data Diagram

Burst PCM Mode

In this mode of operation, the PCM bus runs at a significantly higher rate of operation to allow the host to duty cycle its operation and save current. In this mode of operation, the PCM bus can operate at a rate of up to 24 MHz. This mode of operation is initiated with an HCI command from the host.

Not Recommended for New Designs

PCM Interface Timing

Short Frame Sync, Master Mode

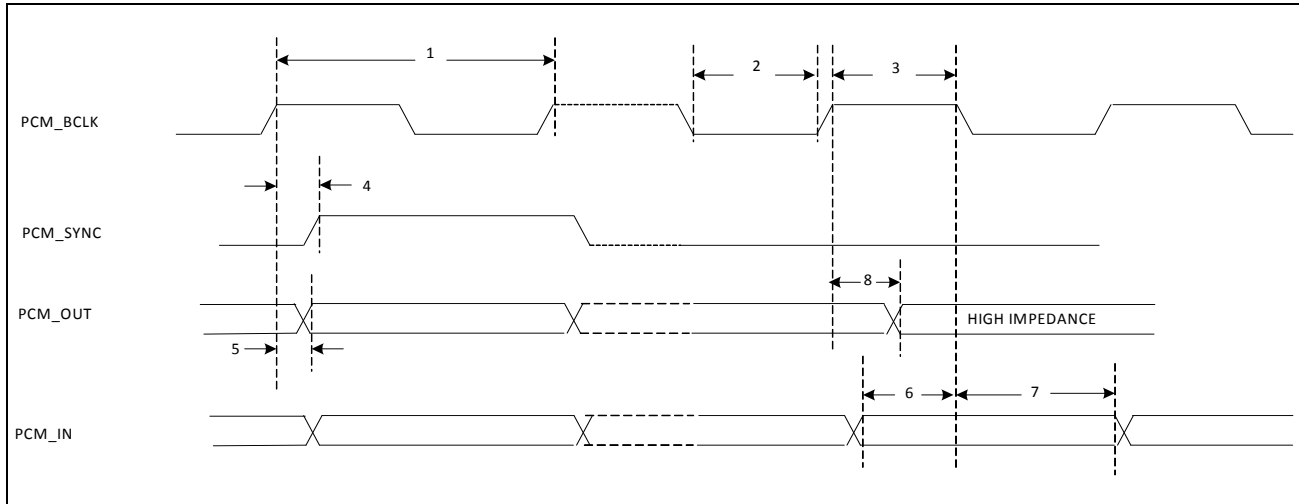

Figure 12: PCM Timing Diagram (Short Frame Sync, Master Mode)

Table 5: PCM Interface Timing Specifications (Short Frame Sync, Master Mode)

Ref No.	Characteristics	Minimum	Typical	Maximum	Unit
1	PCM bit clock frequency	–	–	12	MHz
2	PCM bit clock HIGH	41	–	–	ns
3	PCM bit clock LOW	41	–	–	ns
4	PCM_SYNC delay	0	–	25	ns
5	PCM_OUT delay	0	–	25	ns
6	PCM_IN setup	8	–	–	ns
7	PCM_IN hold	8	–	–	ns
8	Delay from rising edge of PCM_BCLK during last bit period to PCM_OUT becoming high impedance	0	–	25	ns

Not Recommended for New Designs

Short Frame Sync, Slave Mode

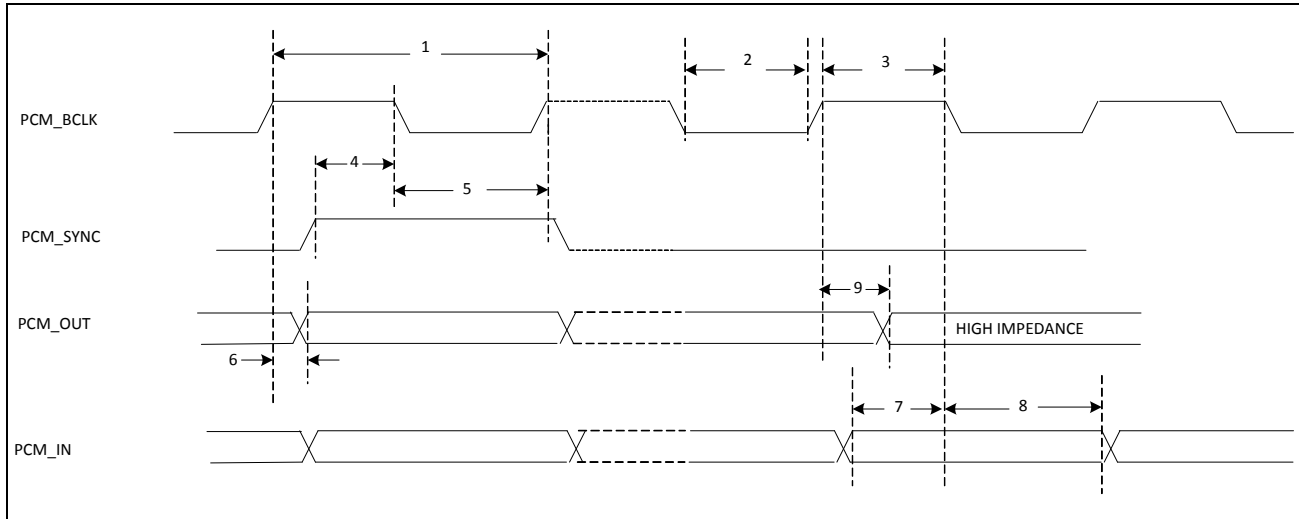

Figure 13: PCM Timing Diagram (Short Frame Sync, Slave Mode)

Table 6: PCM Interface Timing Specifications (Short Frame Sync, Slave Mode)

Ref No.	Characteristics	Minimum	Typical	Maximum	Unit
1	PCM bit clock frequency	–	–	12	MHz
2	PCM bit clock HIGH	41	–	–	ns
3	PCM bit clock LOW	41	–	–	ns
4	PCM_SYNC setup	8	–	–	ns
5	PCM_SYNC hold	8	–	–	ns
6	PCM_OUT delay	0	–	25	ns
7	PCM_IN setup	8	–	–	ns
8	PCM_IN hold	8	–	–	ns
9	Delay from rising edge of PCM_BCLK during last bit period to PCM_OUT becoming high impedance	0	–	25	ns

Not Recommended for New Designs

Long Frame Sync, Master Mode

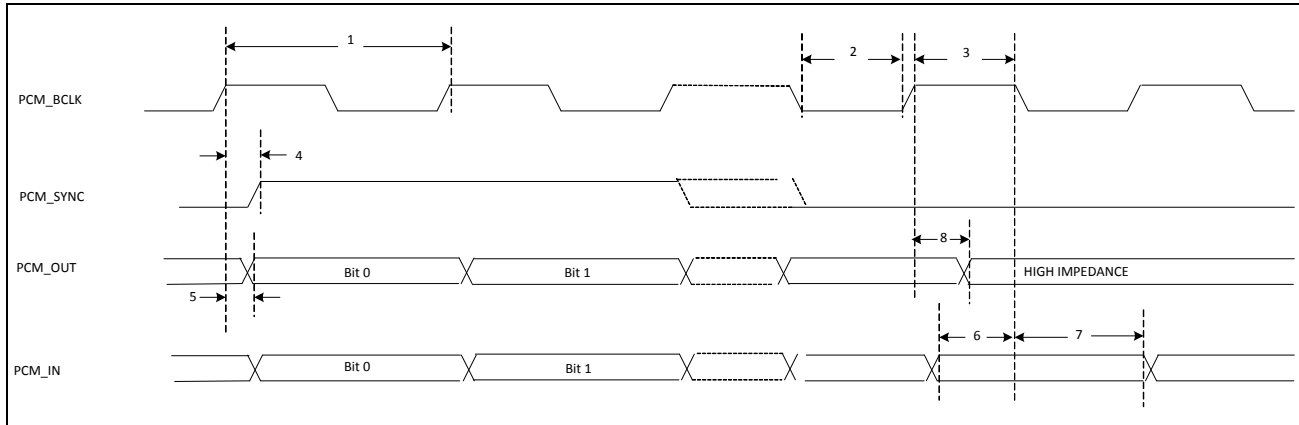

Figure 14: PCM Timing Diagram (Long Frame Sync, Master Mode)

Table 7: PCM Interface Timing Specifications (Long Frame Sync, Master Mode)

Ref No.	Characteristics	Minimum	Typical	Maximum	Unit
1	PCM bit clock frequency	–	–	12	MHz
2	PCM bit clock HIGH	41	–	–	ns
3	PCM bit clock LOW	41	–	–	ns
4	PCM_SYNC delay	0	–	25	ns
5	PCM_OUT delay	0	–	25	ns
6	PCM_IN setup	8	–	–	ns
7	PCM_IN hold	8	–	–	ns
8	Delay from rising edge of PCM_BCLK during last bit period to PCM_OUT becoming high impedance	0	–	25	ns

Not Recommended for New Designs

Long Frame Sync, Slave Mode

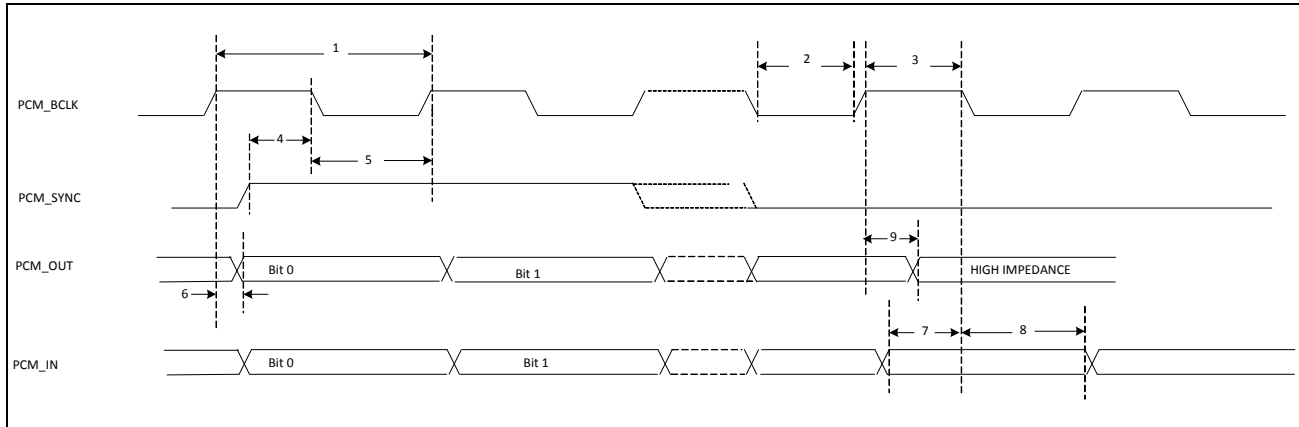

Figure 15: PCM Timing Diagram (Long Frame Sync, Slave Mode)

Table 8: PCM Interface Timing Specifications (Long Frame Sync, Slave Mode)

Ref No.	Characteristics	Minimum	Typical	Maximum	Unit
1	PCM bit clock frequency	–	–	12	MHz
2	PCM bit clock HIGH	41	–	–	ns
3	PCM bit clock LOW	41	–	–	ns
4	PCM_SYNC setup	8	–	–	ns
5	PCM_SYNC hold	8	–	–	ns
6	PCM_OUT delay	0	–	25	ns
7	PCM_IN setup	8	–	–	ns
8	PCM_IN hold	8	–	–	ns
9	Delay from rising edge of PCM_BCLK during last bit period to PCM_OUT becoming high impedance	0	–	25	ns

Not Recommended for New Designs

Short Frame Sync, Burst Mode

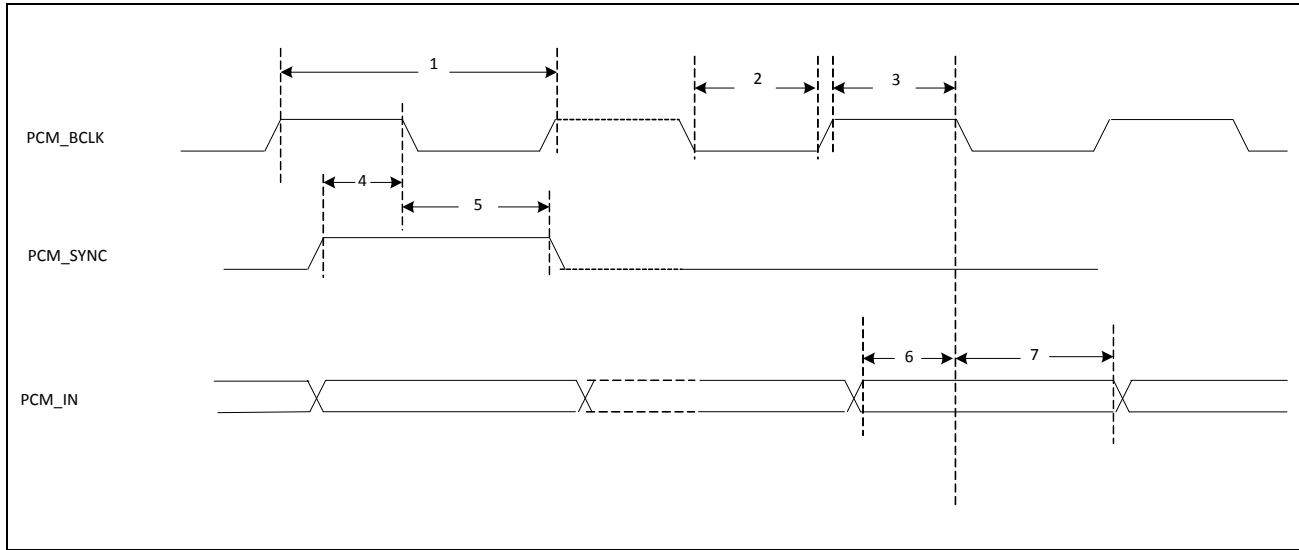

Figure 16: PCM Burst Mode Timing (Receive Only, Short Frame Sync)

Table 9: PCM Burst Mode (Receive Only, Short Frame Sync)

Ref No.	Characteristics	Minimum	Typical	Maximum	Unit
1	PCM bit clock frequency	–	–	24	MHz
2	PCM bit clock HIGH	20.8	–	–	ns
3	PCM bit clock LOW	20.8	–	–	ns
4	PCM_SYNC setup	8	–	–	ns
5	PCM_SYNC hold	8	–	–	ns
6	PCM_IN setup	8	–	–	ns
7	PCM_IN hold	8	–	–	ns

Not Recommended for New Designs

Long Frame Sync, Burst Mode

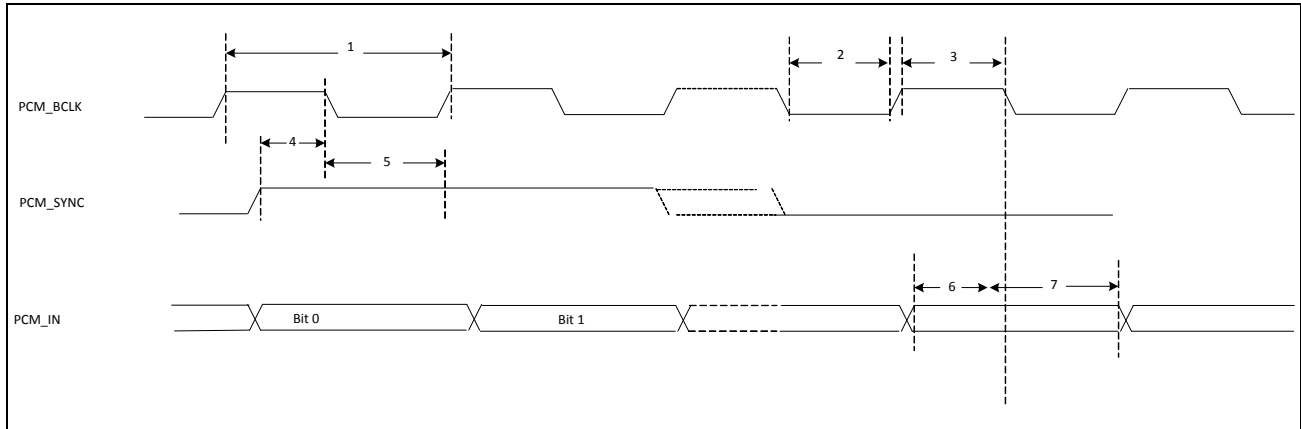

Figure 17: PCM Burst Mode Timing (Receive Only, Long Frame Sync)

Table 10: PCM Burst Mode (Receive Only, Long Frame Sync)

Ref No.	Characteristics	Minimum	Typical	Maximum	Unit
1	PCM bit clock frequency	–	–	24	MHz
2	PCM bit clock HIGH	20.8	–	–	ns
3	PCM bit clock LOW	20.8	–	–	ns
4	PCM_SYNC setup	8	–	–	ns
5	PCM_SYNC hold	8	–	–	ns
6	PCM_IN setup	8	–	–	ns
7	PCM_IN hold	8	–	–	ns

Not Recommended for New Designs

UART Interface

The BCM4330 shares a single UART for Bluetooth and FM. The UART is a standard 4-wire interface (RX, TX, RTS, and CTS) with adjustable baud rates from 9600 bps to 4.0 Mbps. The interface features an automatic baud rate detection capability that returns a baud rate selection. Alternatively, the baud rate may be selected through a vendor-specific UART HCI command.

UART has a 1040-byte receive FIFO and a 1040-byte transmit FIFO to support EDR. Access to the FIFOs is conducted through the AHB interface through either DMA or the CPU. The UART supports the Bluetooth 4.0 UART HCI specification: H4, a custom Extended H4, and H5. The default baud rate is 115.2 Kbaud.

The UART supports the 3-wire H5 UART transport, as described in the Bluetooth specification (“Three-wire UART Transport Layer”). Compared to H4, the H5 UART transport reduces the number of signal lines required by eliminating the CTS and RTS signals.

The BCM4330 UART can perform XON/XOFF flow control and includes hardware support for the Serial Line Input Protocol (SLIP). It can also perform wake-on activity. For example, activity on the RX or CTS inputs can wake the chip from a sleep state.

Normally, the UART baud rate is set by a configuration record downloaded after device reset, or by automatic baud rate detection, and the host does not need to adjust the baud rate. Support for changing the baud rate during normal HCI UART operation is included through a vendor-specific command that allows the host to adjust the contents of the baud rate registers. The BCM4330 UARTs operate correctly with the host UART as long as the combined baud rate error of the two devices is within $\pm 2\%$.

Table 11: Example of Common Baud Rates

Desired Rate	Actual Rate	Error (%)
4000000	4000000	0.00
3692000	3692308	0.01
3000000	3000000	0.00
2000000	2000000	0.00
1500000	1500000	0.00
1444444	1454544	0.70
921600	923077	0.16
460800	461538	0.16
230400	230796	0.17
115200	115385	0.16
57600	57692	0.16
38400	38400	0.00
28800	28846	0.16
19200	19200	0.00
14400	14423	0.16
9600	9600	0.00

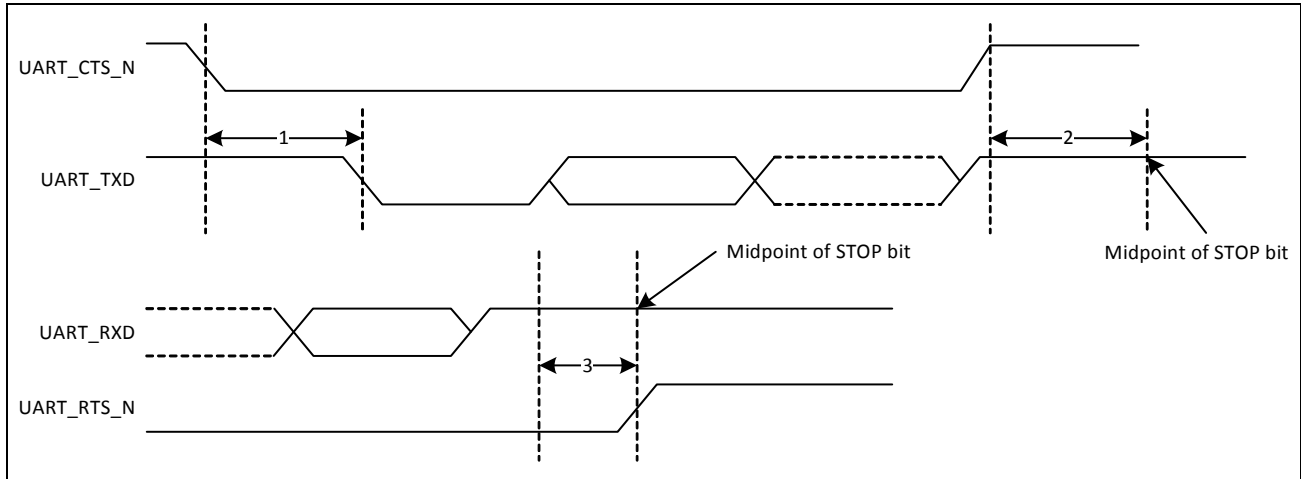

Figure 18: UART Timing

Table 12: UART Timing Specifications

Ref No.	Characteristics	Minimum	Typical	Maximum	Unit
1	Delay time, UART_CTS_N low to UART_TXD valid	–	–	1.5	Bit periods
2	Setup time, UART_CTS_N high before midpoint of stop bit	–	–	0.5	Bit periods
3	Delay time, midpoint of stop bit to UART_RTS_N high	–	–	0.5	Bit periods

Not Recommended for New Designs

I²S Interface

The BCM4330 supports two independent I²S digital audio ports: one for Bluetooth audio, and one for high-fidelity FM audio. The I²S interface for FM audio supports both master and slave modes. The I²S signals are:

- I²S clock: I²S SCK
- I²S Word Select: I²S WS
- I²S Data Out: I²S SDO
- I²S Data In: I²S SDI

I²S SCK and I²S WS become outputs in master mode and inputs in slave mode, while I²S SDO always stays as an output. I²S data input is used for FM Tx. The channel word length is 16 bits and the data is justified so that the MSB of the left-channel data is aligned with the MSB of the I²S bus, per the I²S specification. The MSB of each data word is transmitted one bit clock cycle after the I²S WS transition, synchronous with the falling edge of bit clock. Left-channel data is transmitted when I²S WS is low, and right-channel data is transmitted when I²S WS is high. Data bits sent by the BCM4330 are synchronized with the falling edge of I2S_SCK and should be sampled by the receiver on the rising edge of I2S_SSCK.

The clock rate in master mode is either of the following:

$$48 \text{ kHz} \times 32 \text{ bits per frame} = 1.536 \text{ MHz}$$

$$48 \text{ kHz} \times 50 \text{ bits per frame} = 2.400 \text{ MHz}$$

The master clock is generated from the input reference clock using a N/M clock divider.

In the slave mode, any clock rate is supported to a maximum of 3.072 MHz.

I²S Timing



Note: Timing values specified in [Table 13](#) are relative to high and low threshold levels.

Table 13: Timing for I²S Transmitters and Receivers

	Transmitter				Receiver				Notes
	Lower Limit		Upper Limit		Lower Limit		Upper Limit		
	Min	Max	Min	Max	Min	Max	Min	Max	
Clock Period T	T_{tr}	–	–	–	T_r	–	–	–	1
Master Mode: Clock generated by transmitter or receiver									
HIGH t_{HC}	$0.35T_{tr}$	–	–	–	$0.35T_{tr}$	–	–	–	2
LOW t_{LC}	$0.35T_{tr}$	–	–	–	$0.35T_{tr}$	–	–	–	2
Slave Mode: Clock accepted by transmitter or receiver									
HIGH t_{HC}	–	$0.35T_{tr}$	–	–	–	$0.35T_{tr}$	–	–	3
LOW t_{LC}	–	$0.35T_{tr}$	–	–	–	$0.35T_{tr}$	–	–	3
Rise time t_{RC}	–	–	$0.15T_{tr}$	–	–	–	–	–	4
Transmitter									
Delay t_{dtr}	–	–	–	$0.8T$	–	–	–	–	5
Hold time t_{htr}	0	–	–	–	–	–	–	–	4
Receiver									
Setup time t_{sr}	–	–	–	–	–	$0.2T_r$	–	–	6
Hold time t_{hr}	–	–	–	–	–	0	–	–	6

**Note:**

- The system clock period T must be greater than T_{tr} and T_r because both the transmitter and receiver have to be able to handle the data transfer rate.
- At all data rates in master mode, the transmitter or receiver generates a clock signal with a fixed mark/space ratio. For this reason, t_{HC} and t_{LC} are specified with respect to T.
- In slave mode, the transmitter and receiver need a clock signal with minimum HIGH and LOW periods so that they can detect the signal. So long as the minimum periods are greater than $0.35T_r$, any clock that meets the requirements can be used.
- Because the delay (t_{dtr}) and the maximum transmitter speed (defined by T_{tr}) are related, a fast transmitter driven by a slow clock edge can result in t_{dtr} not exceeding t_{RC} which means t_{htr} becomes zero or negative. Therefore, the transmitter has to guarantee that t_{htr} is greater than or equal to zero, so long as the clock rise-time t_{RC} is not more than t_{RCmax} , where t_{RCmax} is not less than $0.15T_{tr}$.
- To allow data to be clocked out on a falling edge, the delay is specified with respect to the rising edge of the clock signal and T, always giving the receiver sufficient setup time.
- The data setup and hold time must not be less than the specified receiver setup and hold time.



Note: The time periods specified in [Figure 19](#) and [Figure 20](#) are defined by the transmitter speed. The receiver specifications must match transmitter performance.

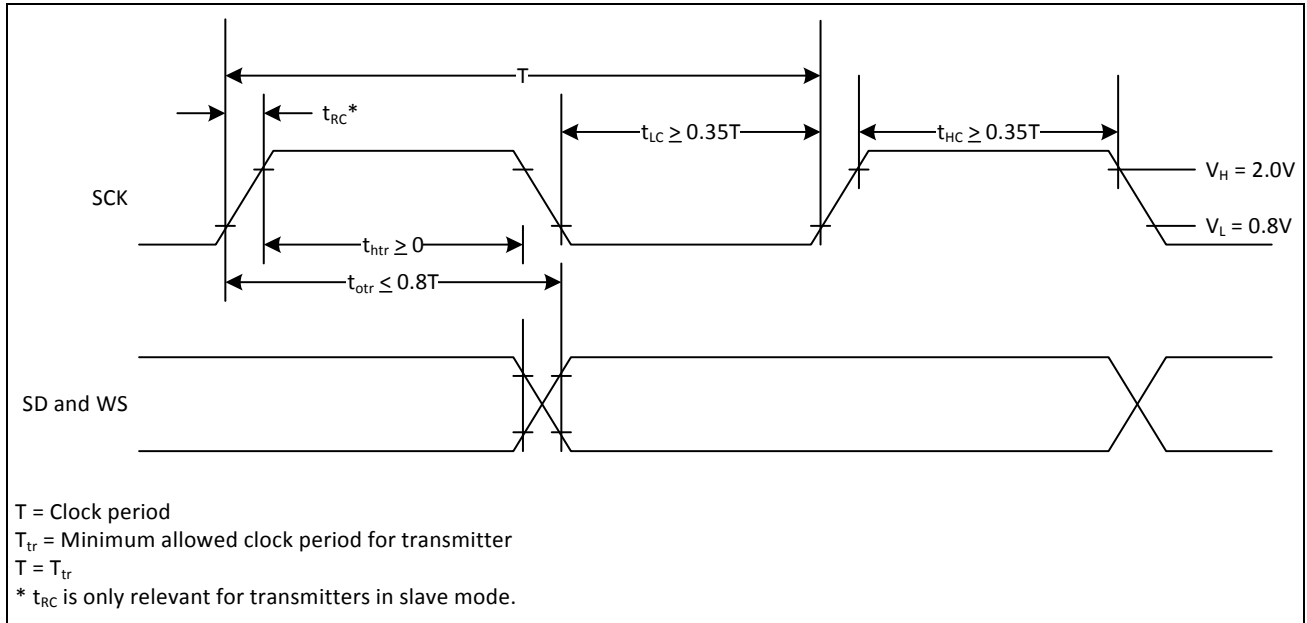

Figure 19: I²S Transmitter Timing

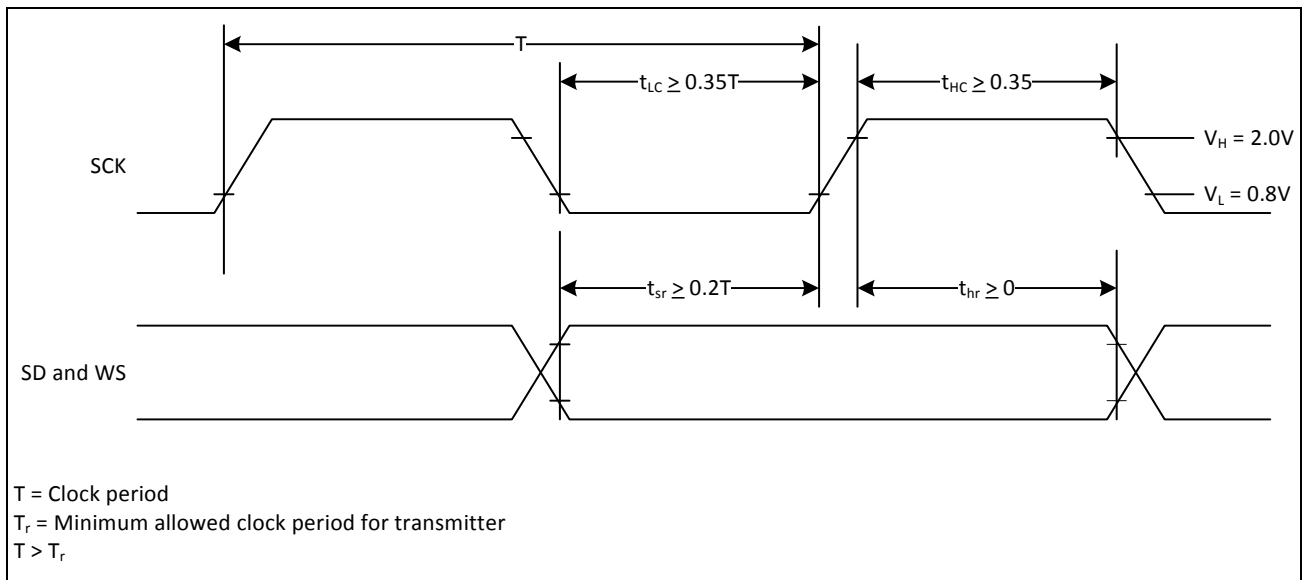

Figure 20: I²S Receiver Timing

Not Recommended for New Designs

Section 9: FM Transceiver Subsystem

FM Radio

The BCM4330 includes a completely integrated FM radio receiver and transmitter with RDS/RBDS covering all FM bands from 65 MHz to 108 MHz. The transceiver is controlled through commands on the HCI. FM received audio is available as stereo analog output or in digital form through I²S or PCM. The FM audio to be transmitted can be delivered via stereo analog audio input or in digital form via the I²S or PCM interface. The FM radio is capable of operating from the 32.768 kHz LPO clock.

Digital FM Audio Interfaces

The FM audio can be received or transmitted via the shared PCM and I²S pins, and the sampling rate is nominally at 48 kHz. The BCM4330 supports a three-wire PCM or I²S audio interface in either master or slave configuration. The master or slave configuration is selected using vendor specific commands over the HCI interface. In addition, multiple sampling rates are supported, derived from either the FM or Bluetooth clocks. In master mode, the clock rate is either of the following:

- 48 kHz x 32 bits per frame = 1.536 MHz
- 48 kHz x 50 bits per frame = 2.400 MHz

In slave mode, any clock rate is supported up to a maximum of 3.072 MHz.

Analog FM Audio Interfaces

The demodulated FM audio signal is available as line-level analog stereo output, generated by twin internal high SNR audio DACs.

FM Over Bluetooth

The BCM4330 can output received FM audio onto Bluetooth using one of following three links: eSCO, WBS, and A2DP. In all of the above modes, once the link has been set up, the host processor can enter sleep mode while the BCM4330 continues to stream FM audio to the remote Bluetooth device, allowing the system current consumption to be minimized.

Not Recommended for New Designs

eSCO

In this use case, the stereo FM audio is downsampled to 8 kHz and a mono or stereo stream is then sent through the Bluetooth eSCO link to a remote Bluetooth device, typically a headset. Two Bluetooth voice connections must be used to transport stereo.

Wide Band Speech Link

In this case, the stereo FM audio is downsampled to 16 kHz and a mono or stereo stream is then sent through the Bluetooth wideband speech link to a remote Bluetooth device, typically a headset. Two Bluetooth voice connections must be used to transport stereo.

A2DP

In this case, the stereo FM audio is encoded by the on-chip SBC encoder and transported as an A2DP link to a remote Bluetooth device. Sampling rates of 48 kHz, 44.1 kHz, and 32 kHz joint stereo are supported. An A2DP “lite” stack is implemented in the BCM4330 to support this use case, which eliminates the need to route the SBC-encoded audio back to the host to create the A2DP packets.

Dynamic Antenna Switching

The BCM4330 includes a circuit to detect the presence of ground-coupled antenna.

Not Recommended for New Designs

Autotune and Search Algorithms

The BCM4330 supports a number of FM search and tune functions that allows the host to implement many convenient user functions, which are accessed through the Broadcom FM stack.

- **Tune to Play**— Allows the FM receiver to be programmed to a specific frequency.
- **Search for RSSI > Threshold**— Searches for valid FM channels within the band that have signal strength above a specified threshold. This function can be set to search for the next valid channel up or down the band or can be set to search for a list of valid channels across the entire band.
- **Search for RSSI < Threshold**— Searches for empty or under-utilized channels that can be used to transmit FM. Available channels can be identified before suggesting an FM transmit channel to the user. This allows the BCM4330 to determine the best channel for FM transmit operation instead of requiring the user to find an unused channel manually.
- **Search for SNR > Threshold**— Checks the power level of the available channel and the estimated SNR of the channel to help achieve precise control of the expected sound quality for the selected FM channel. Specifically, the host can adjust its SNR requirements to retrieve a signal with a specific sound quality, or adjust this to return the weakest channels.
- **Alternate Frequency Jump**— Allows the FM receiver to automatically jump to an alternate FM channel that carries the same information, but has a better SNR. For example, when traveling, a user may pass through a region where a number of channels carry the same station. When the user passes from one area to the next, the FM receiver can automatically switch to another channel with a stronger signal to spare the user from having to manually change the channel to continue listening to the same station.

Audio Features

A number of features are implemented in the BCM4330 to provide the best possible audio experience for the user.

- **Mono/Stereo Blend or Switch**— The BCM4330 provides automatic control of the stereo or mono settings based on the RSSI and estimated audio SNR. This feature is used to achieve a minimum audio SNR based on the channel conditions. Two modes of operation are supported:
 - **Blend**— In this mode, fine control of stereo separation is used to achieve optimal audio quality over a wide range of input C/N. The amount of separation is fully programmable. In [Figure 21](#), the separation is programmed to maintain a minimum 50 dB SNR across the blend range.
 - **Switch**— In this mode, the audio switches from full stereo to full mono at a predetermined level to maintain optimal audio quality. The stereo-to-mono switch point and the mono-to-stereo switch points are fully programmable to provide the desired amount of audio SNR. In [Figure 22](#), the switch point is programmed to switch to mono to maintain a 40 dB SNR.

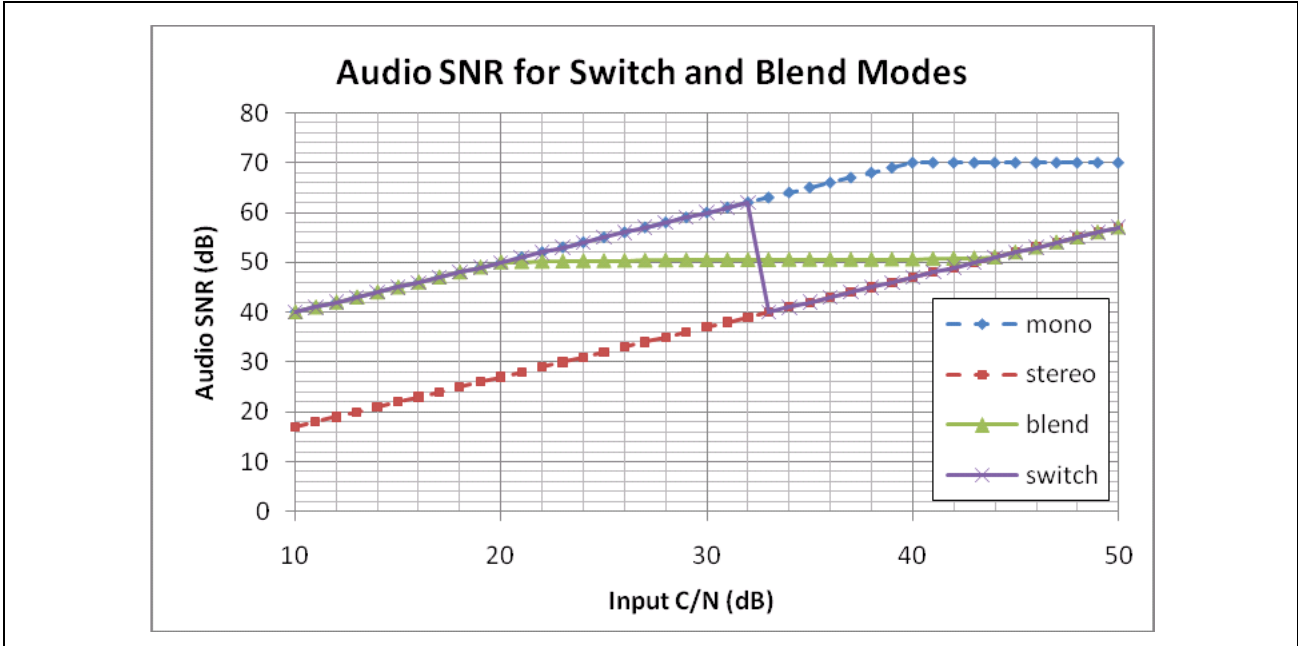

Figure 21: Example Blend/Switch Usage

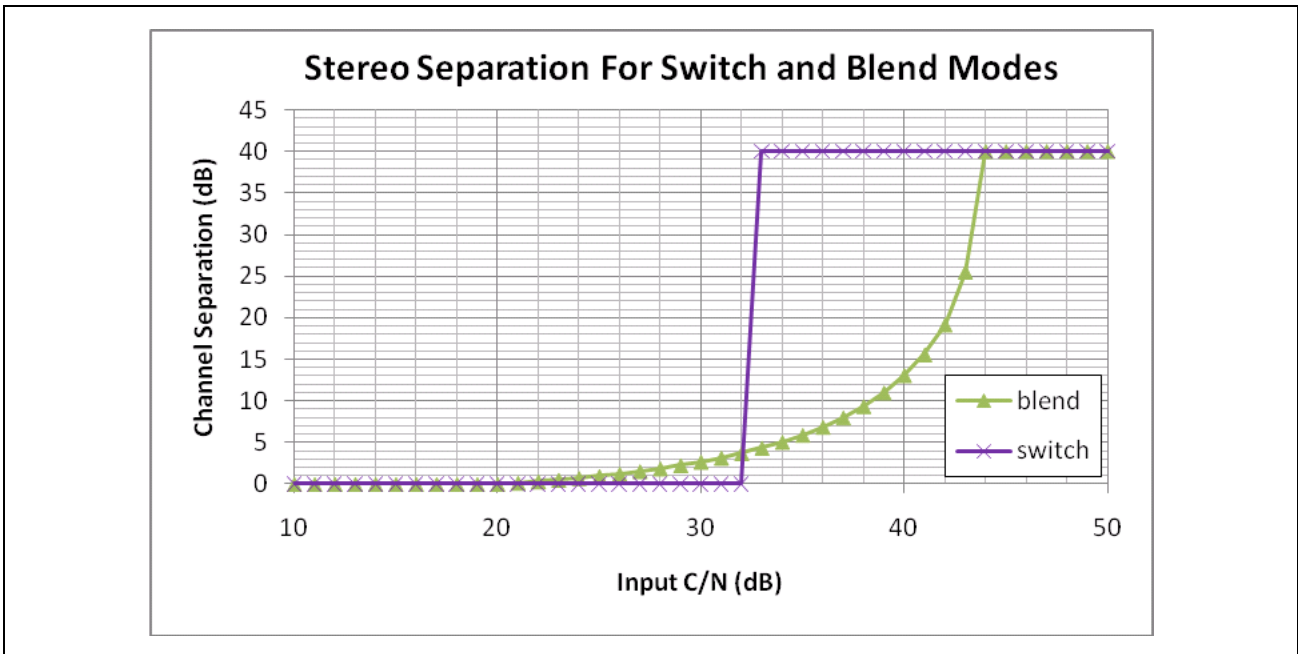

Figure 22: Example Blend/Switch Separation

- Soft Mute—Improves the user experience by dynamically muting the output audio proportionate to the FM signal C/N. This prevents the user from being assaulted with a blast of static. The mute characteristic is fully programmable to accommodate fine tuning of the output signal level. An example mute characteristic is shown in [Figure 23](#).

Not Recommended for New Designs

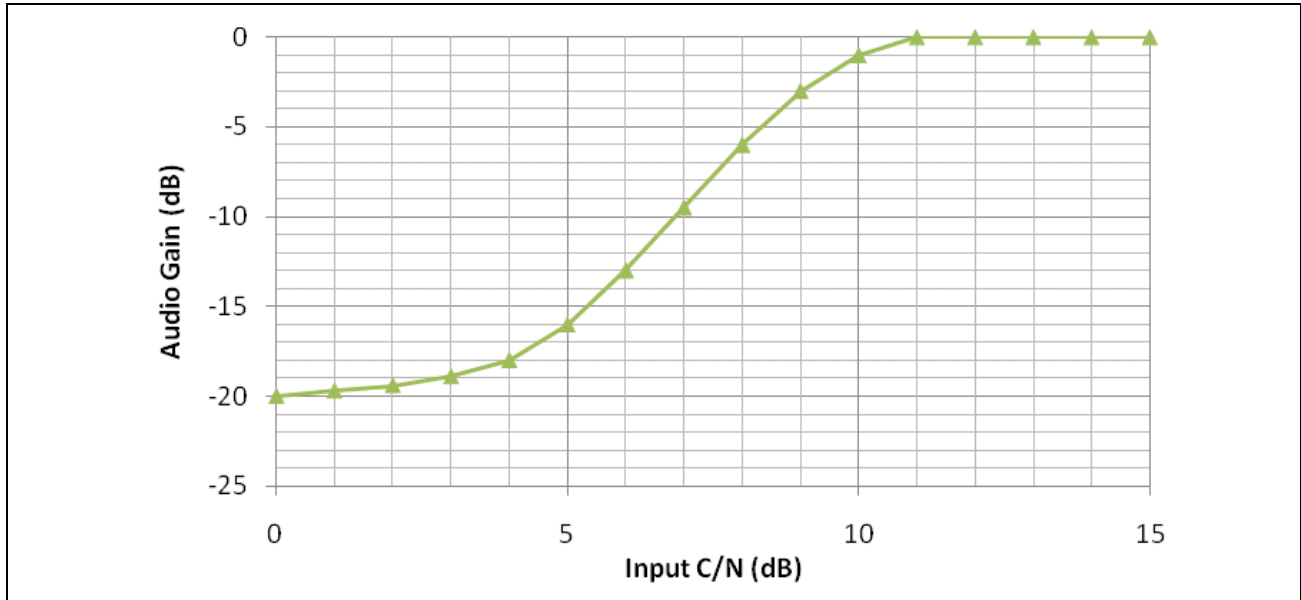

Figure 23: Example Soft Mute Characteristic

- Audio Pause Detect — The FM receiver monitors the magnitude of the audio signal and notifies the host through an interrupt when the magnitude of the signal has fallen below the threshold set for a programmable period. This feature can be used to provide alternate frequency jumps during periods of silence to minimize disturbances to the listener. Filtering techniques are used within the audio pause detection block to provide more robust presence-to-silence detection and silence-to-presence detection.

On-Chip MP3 Encoding

In this mode of operation, the device can record the FM audio to MP3, then output the MP3 data over the HCI interface. The feature effectively off loads the MP3 recording processing load from the host and assists in FM time shift applications. This feature can also be used in conjunction with burst mode buffering to provide significant FM system record times.

Not Recommended for New Designs

RDS/RBDS

The BCM4330 integrates a RDS/RBDS modem and codec, the decoder includes programmable filtering and buffering functions, and the encoder includes the option to encode messages to PS or RT frame format with programmable scrolling in PS mode. The RDS/RBDS data can be read out in receive mode or delivered in transmit mode through the HCI interface.

In addition, the RDS/RBDS functionality supports the following:

Receive

- Block decoding, error correction and synchronization
- Flywheel synchronization feature, allowing the host to set parameters for acquisition, maintenance, and loss of sync. (It is possible to set up the BCM4330 such that synch is achieved when a minimum of two good blocks (error free) are decoded in sequence. The number of good blocks required for sync is programmable.)
- Storage capability up to 126 blocks of RDS data
- Full or partial block B match detect and interrupt to host
- Audio pause detection with programmable parameters
- Program Identification (PI) code detection and interrupt to host
- Automatic frequency jump
- Block E filtering

Transmit

- Support simple block encoding or RT/PS message to frame encoding (RT/PS mode minimizes host communication for improved system power saving)
- Programmable scroll rate in PS mode
- 256 bytes of storage for either RT/PS message or simple RDS/RBDS blocks
-

Section 10: WLAN Global Functions

WLAN CPU and Memory Subsystem

The BCM4330 includes an integrated ARM Cortex-M3™ processor with internal RAM and ROM. The ARM Cortex-M3 processor is a low-power processor that features low gate count, low interrupt latency, and low-cost debug. It is intended for deeply embedded applications that require fast interrupt response features. The processor implements the ARM architecture v7-M with support for Thumb®-2 instruction set. ARM Cortex-M3 delivers 30% more performance gain over ARM7TDMI.

At 0.19uW/MHz, the Cortex-M3 is the most power efficient general purpose microprocessor available, outperforming 8- and 16-bit devices on MIPS/uW. It supports integrated sleep modes.

ARM Cortex-M3 uses multiple technologies to reduce cost through improved memory utilization, reduced pin overhead, and reduced silicon area. ARM Cortex-M3 supports independent buses for Code and Data access (ICode/DCode and System buses). ARM Cortex-M3 supports extensive debug features including real time trace of program execution.

On-chip memory for the CPU includes 288 KB SRAM and 512 KB ROM.

One-Time-Programmable Memory

Various hardware configuration parameters may be stored in an internal 2 Kbit one-time-programmable (OTP) memory, which is read by system software after device reset. In addition, customer-specific parameters, including the system vendor ID and the MAC address can be stored, depending on the specific board design.

The initial state of all bits in an unprogrammed OTP device is 0. After any bit is programmed to a 1, it cannot be reprogrammed to 0. The entire OTP array can be programmed in a single write cycle using a utility provided with the Broadcom WLAN manufacturing test tools. Alternatively, multiple write cycles can be used to selectively program specific bytes, but only bits which are still in the 0 state can be altered during each programming cycle.

Prior to OTP programming, all values should be verified using the appropriate editable nvram.txt file, which is provided with the reference board design package. Documentation on the OTP development process is available on the Broadcom customer support portal (<http://www.broadcom.com/support>).

GPIO Interface

There are seven general purpose I/O (GPIO) pins available on the WLAN section of the BCM4330 that can be used to connect to various external devices.

Upon power up and reset, these pins become tri-stated. Subsequently, they can be programmed to be either input or output pins via the GPIO control register. An internal pull-up resistor is included on each GPIO. If a GPIO output enable is not asserted, and the corresponding GPIO signal is not being driven externally, the GPIO is read as high.

External Coexistence Interface

An external handshake interface is available to enable signaling between the device and an external co-located wireless device, such as GPS, WiMax, or UWB, to manage wireless medium sharing for optimum performance. The following signals can be enabled by software on the indicated WL_GPIO pins:

- ERCX_STATUS — WL_GPIO1
- ERCX_FREQ — WL_GPIO2
- ERCX_RF_ACTIVE — WL_GPIO3
- ERCX_TXCONF — WL_GPIO4
- ERCX_PRISEL — WL_GPIO5

UART Interface

One UART interface can be enabled by software as an alternate function on pins WL_GPIO4 and WL_GPIO_3. Provided primarily for debugging during development, this UART enables the BCM4330 to operate as RS-232 data termination equipment (DTE) for exchanging and managing data with other serial devices. It is compatible with the industry standard 16550 UART, and it provides a FIFO size of 64 × 8 in each direction.

JTAG Interface

The BCM4330 supports the IEEE 1149.1 JTAG boundary scan standard for performing device package and PCB assembly testing during manufacturing. In addition, the JTAG interface allows Broadcom to assist customers by using proprietary debug and characterization test tools during board bringup. Therefore, it is highly recommended to provide access to the JTAG pins by means of test points or a header on all PCB designs.



Caution! The BCM4330 I/O interface pins are not 3.3V tolerant. All I/O signaling should be limited to 2.9V ±3%, 2.5V, 1.8V, or 1.2V, depending on the I/O power supply voltage VDDIO. This applies to the GPIO, External Coexistence, UART, and JTAG signals.

Section 11: WLAN Host Interfaces

SDIO v2.0

The BCM4330 WLAN section supports SDIO version 2.0. for both 1-bit (25 Mbps), 4-bit modes (100 Mbps), and high speed 4-bit (50 MHz clocks — 200 Mbps). It has the ability to map the interrupt signal onto a GPIO pin. This out-of-band interrupt signal notifies the host when the WLAN device wants to turn on the SDIO interface. The ability to force control of the gated clocks from within the WLAN chip is also provided.

SDIO mode is enabled using the strapping option pins strap_host_ifc_[3:1] ([Table 19: “WLAN GPIO Functions and Strapping Options,” on page 112](#)).

Three functions are supported:

- Function 0 Standard SDIO function (Max BlockSize/ByteCount = 32B)
- Function 1 Backplane Function to access the internal System On Chip (SOC) address space (Max BlockSize/ByteCount = 64B)
- Function 2 WLAN Function for efficient WLAN packet transfer through DMA (Max BlockSize/ByteCount = 512B)

SDIO Pin Descriptions



Caution! The SDIO interface pins are not 3.3V tolerant. All SDIO signaling should be limited to 2.9V \pm 3%, 2.5V, 1.8V, or 1.2V, depending on the I/O power supply voltage VDDIO.

Table 14: SDIO Pin Description

<i>SD 4-Bit Mode</i>		<i>SD 1-Bit Mode</i>		<i>gSPI Mode</i>	
DATA0	Data line 0	DATA	Data line	DO	Data output
DATA1	Data line 1 or Interrupt	IRQ	Interrupt	IRQ	Interrupt
DATA2	Data line 2 or Read Wait	RW	Read Wait	NC	Not used
DATA3	Data line 3	N/C	Not used	CS	Card select
CLK	Clock	CLK	Clock	SCLK	Clock
CMD	Command line	CMD	Command line	DI	Data input

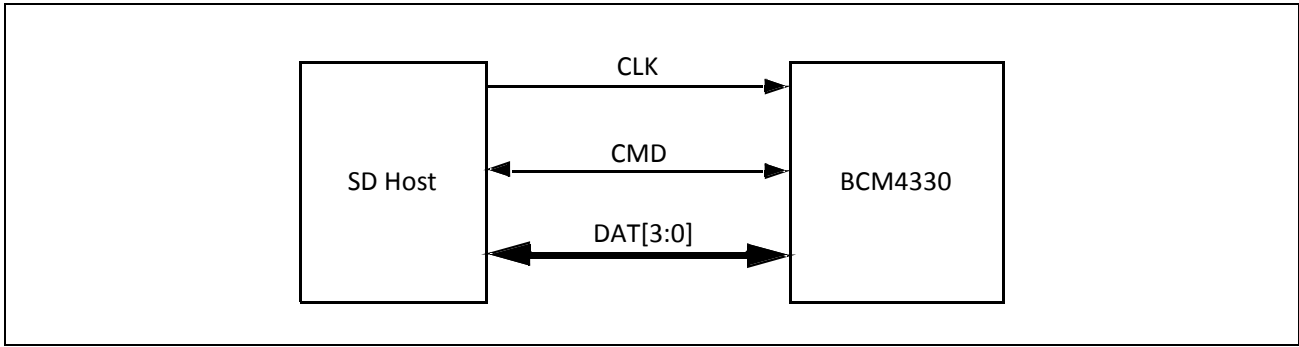

Figure 24: Signal Connections to SDIO Host (SD 4-Bit Mode)

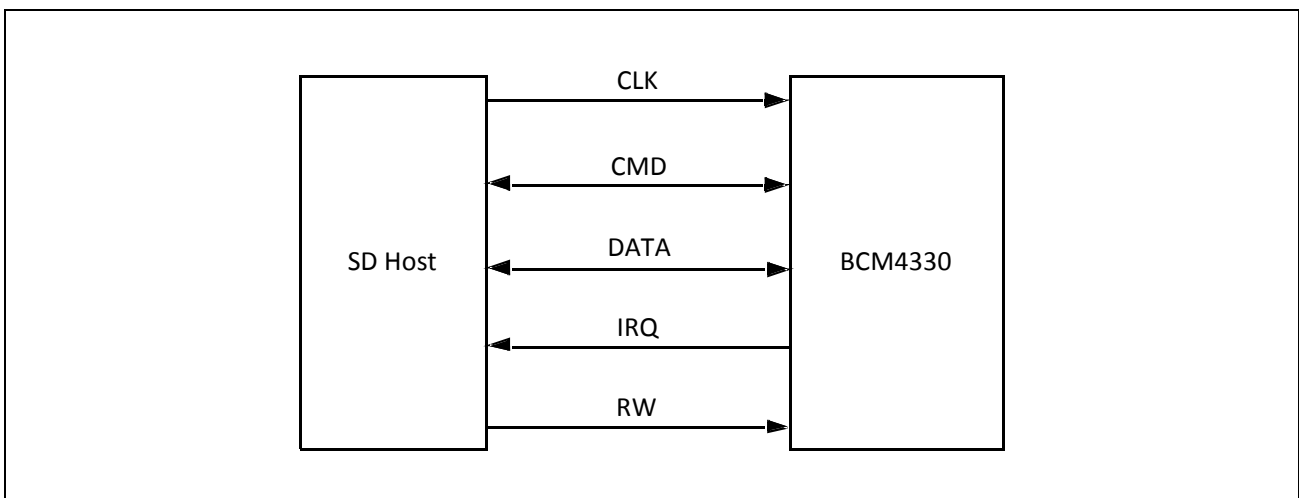

Figure 25: Signal Connections to SDIO Host (SD 1-Bit Mode)

Not Recommended for New Designs

Generic SPI Mode

In addition to the full SDIO mode, the BCM4330 includes the option of using the simplified generic SPI (gSPI) interface/protocol. Characteristics of the gSPI mode include:

- Supports up to 48 MHz operation
- Supports fixed delays for responses and data from device
- Supports alignment to host gSPI frames (16- or 32-bits)
- Supports up to 2 KB frame size per transfer
- Supports little endian and big endian configurations
- Supports configurable active edge for shifting
- Supports packet transfer through DMA for WLAN

gSPI mode is enabled using the strapping option pins strap_host_ifc_[3:1], [Table 19: “WLAN GPIO Functions and Strapping Options,”](#) on page 112.

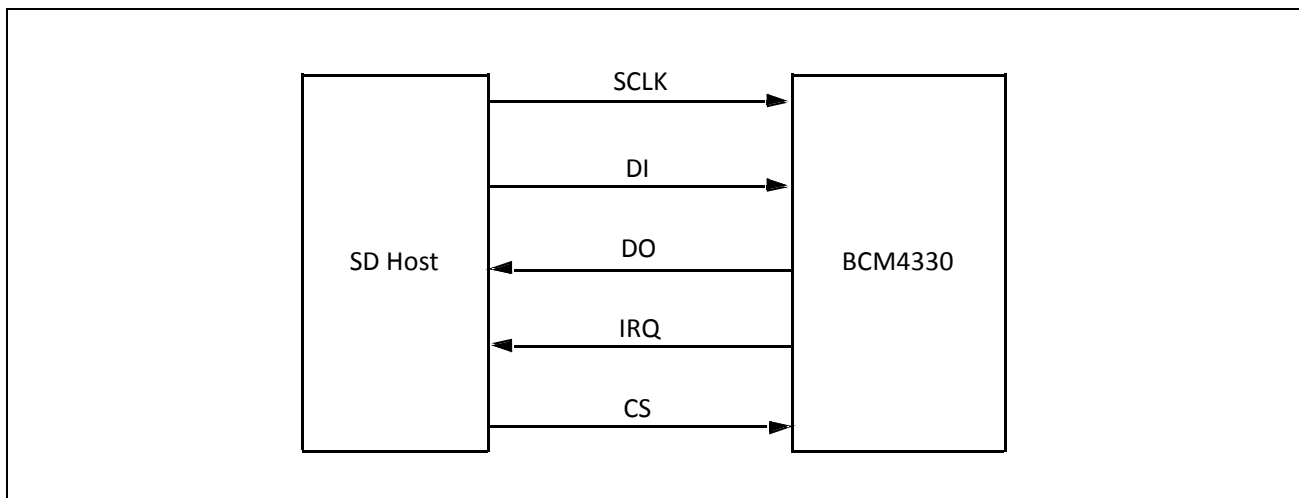

Figure 26: Signal Connections to SDIO Host (gSPI Mode)

SPI Protocol

The SPI protocol supports both 16-bit and 32-bit word operation. Byte endianness is supported in both modes. Figure 27 and Figure 28 show the basic write and write/read commands.

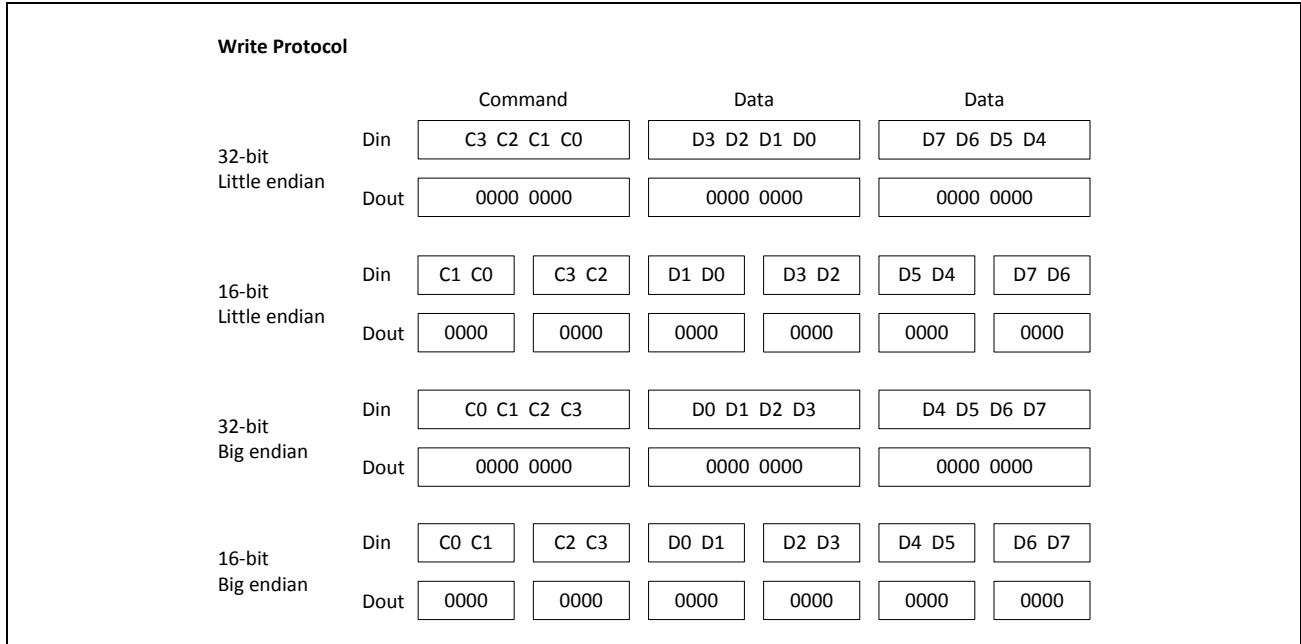

Figure 27: gSPI Write Protocol

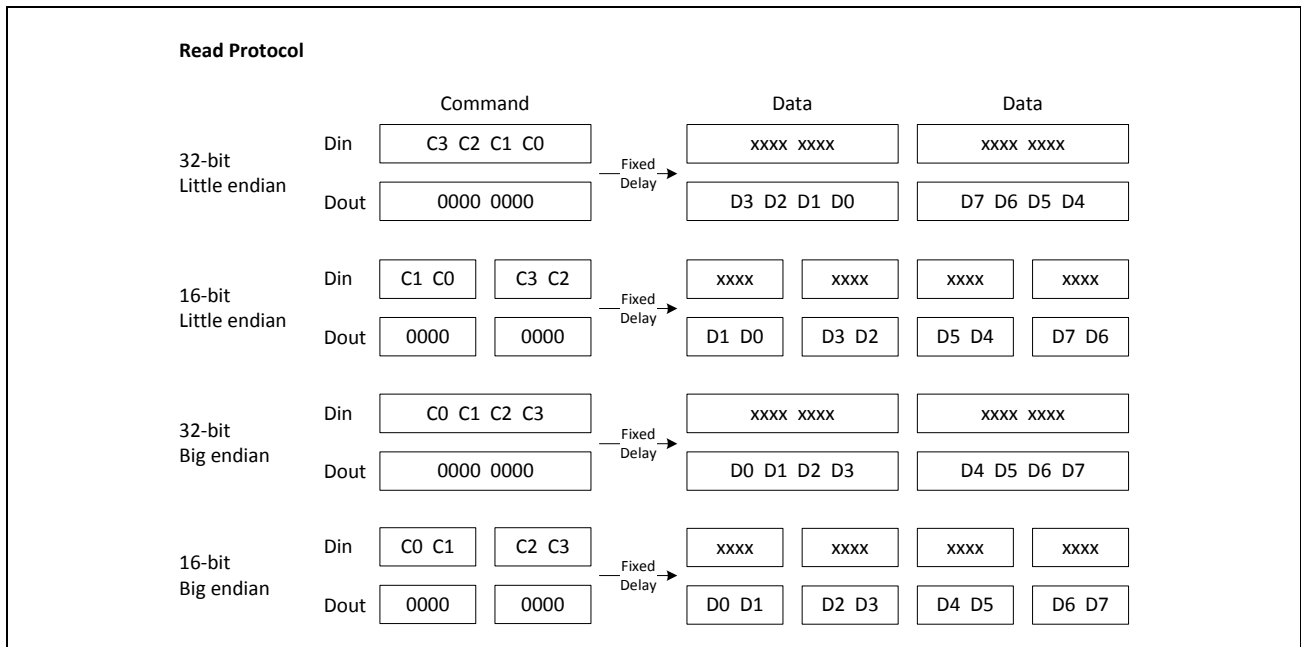

Figure 28: gSPI Read Protocol

Not Recommended for New Designs

Command Structure

The gSPI command structure is 32 bits. The bit positions and definitions are as shown in [Figure 29](#).

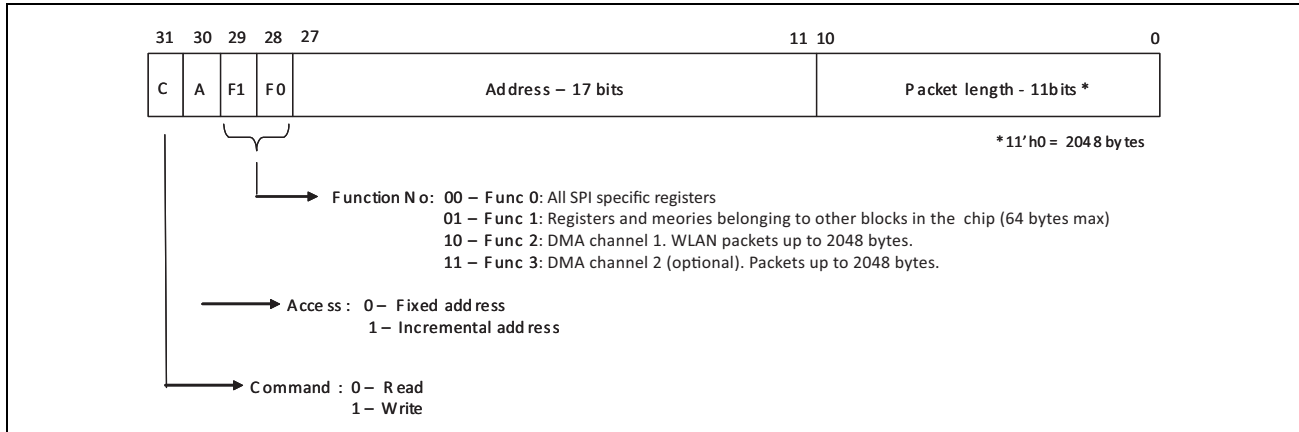

Figure 29: gSPI Command Structure

Write

The host puts the first bit of the data onto the bus half a clock-cycle before the first active edge following the CS going low. The following bits are clocked out on the falling edge of the gSPI clock. The device samples the data on the active edge.

Write/Read

The host reads on the rising edge of the clock requiring data from the device to be made available before the first rising clock edge of the clock burst for the data. The last clock edge of the fixed delay word can be used to represent the first bit of the following data word. This allows data to be ready for the first clock edge without relying on asynchronous delays.

Read

The read command always follows a separate write to set up the WLAN device for a read. This command differs from the write/read command in the following respects: a) chip selects go high between the command/address and the data and b) the time interval between the command/address is not fixed.

Not Recommended for New Designs

Status

The gSPI interface supports status notification to the host after a read/write transaction. This status notification provides information about any packet errors, protocol errors, information about available packet in the RX queue, etc. The status information helps in reducing the number of interrupts to the host. The status-reporting feature can be switched off using a register bit, without any timing overhead. The gSPI bus timing for read/write transactions with and without status notification are as shown in Figure 30 and Figure 31 on page 80. See Table 15 on page 80 for information on status field details.

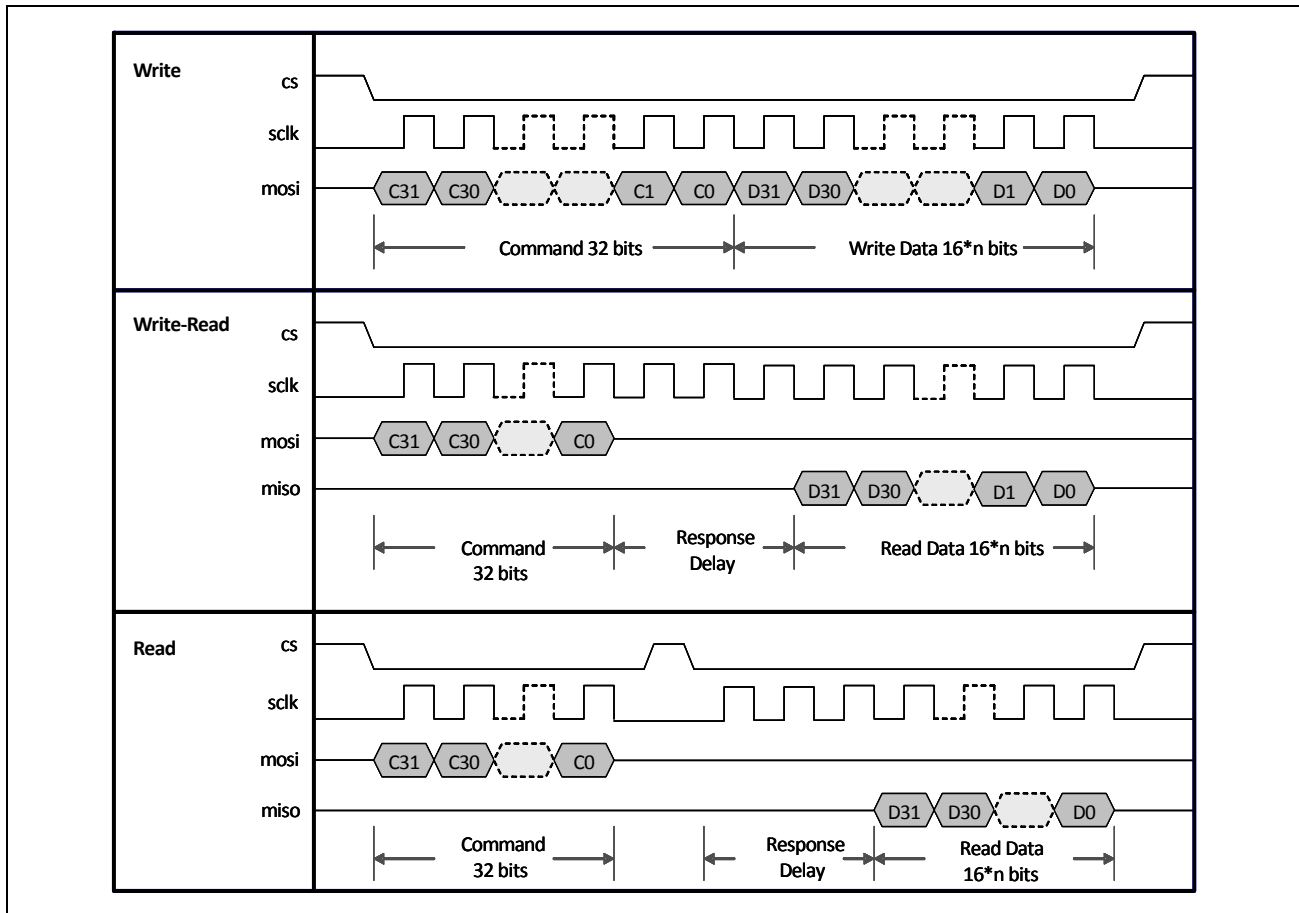

Figure 30: gSPI Signal Timing Without Status

Not Recommended for New Designs

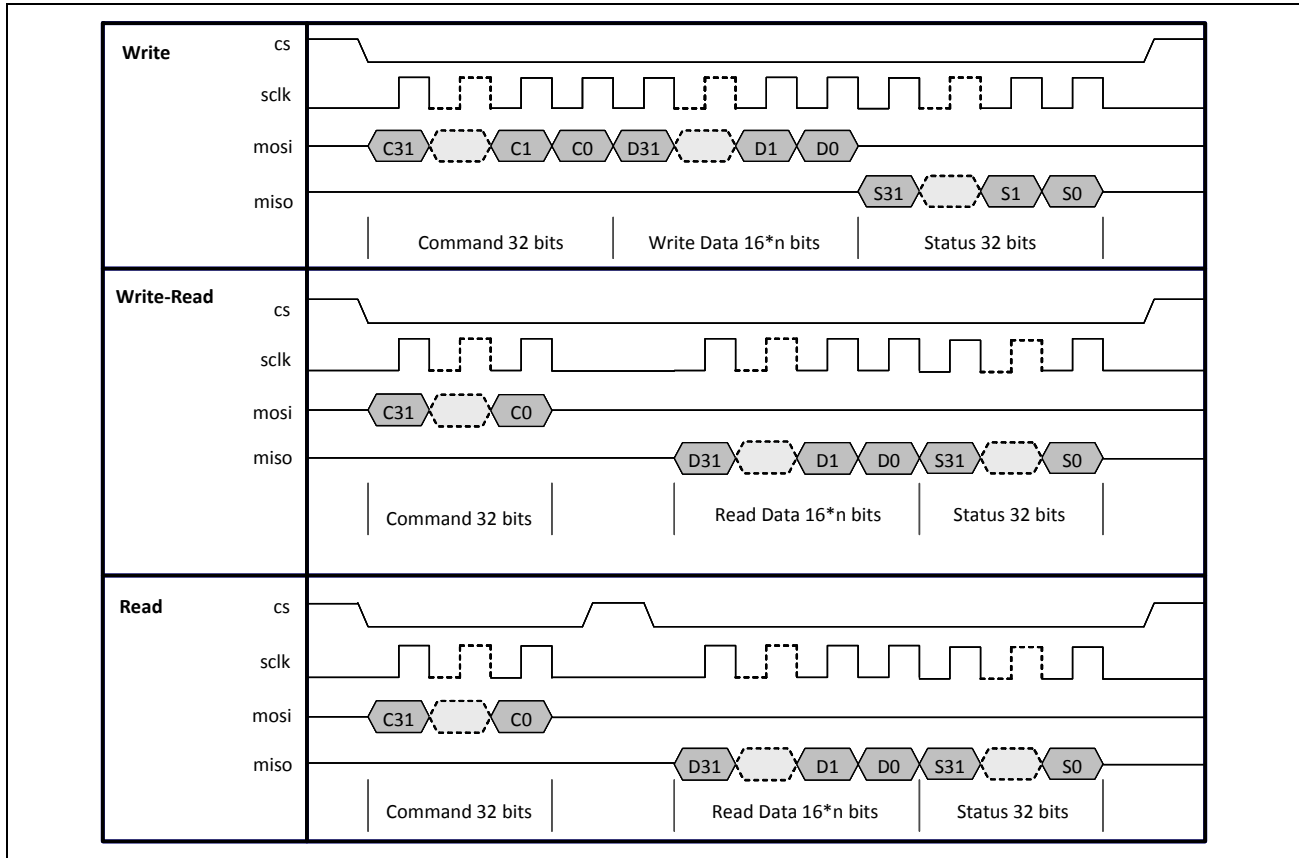

Figure 31: gSPI Signal Timing with Status (Response Delay = 0)

Table 15: gSPI Status Field Details

Bit	Name	Description
0	Data not available	The requested read data is not available
1	Underflow	FIFO underflow occurred due to current (F2, F3) read command
2	Overflow	FIFO overflow occurred due to current (F1, F2, F3) write command
3	F2 interrupt	F2 channel interrupt
4	F3 interrupt	F3 channel interrupt
5	F2 RX Ready	F2 FIFO is ready to receive data (FIFO empty)
6	F3 RX Ready	F3 FIFO is ready to receive data (FIFO empty)
7	Reserved	–
8	F2 Packet Available	Packet is available/ready in F2 TX FIFO
9:19	F2 Packet Length	Length of packet available in F2 FIFO
20	F3 Packet Available	Packet is available/ready in F3 TX FIFO
21:31	F3 Packet Length	Length of packet available in F3 FIFO

gSPI Host-Device Handshake

To initiate communication through the gSPI after power-up, the host needs to bring up the WLAN/Chip by writing to the wake-up WLAN register bit. Writing a 1 to this bit will start up the necessary crystals and PLLs so that the BCM4330 is ready for data transfer. The device can signal an interrupt to the host indicating that the device is awake and ready. This procedure also needs to be followed for waking up the device in sleep mode. The device can interrupt the host using the WLAN IRQ line whenever it has any information to pass to the host. On getting an interrupt, the host needs to read the interrupt and/or status register to determine the cause of interrupt and then take necessary actions.

Boot-Up Sequence

After power-up, the gSPI host needs to wait 150 ms for the device to be out of reset. For this, the host needs to poll with a read command to F0 addr 0x14. Address 0x14 contains a predefined bit pattern. As soon as the host gets a response back with the correct register content, it implies that the device has powered up and is out of reset. After that, the host needs to set the wakeup-WLAN bit (F0 reg 0x00 bit 7). The wakeup-WLAN issues a clock request to the PMU.

For the first time after power-up, the host needs to wait for the availability of low power clock inside the device. Once that is available, the host needs to write to a PMU register to set the crystal frequency. This will turn on the PLL. After the PLL is locked, the chipActive interrupt is issued to the host. This indicates device awake/ready status. See [Table 16](#) for information on gSPI registers.

In [Table 16](#), the following notation is used for register access:

- R: Readable from host and CPU
- W: Writable from host
- U: Writable from CPU

Table 16: gSPI Registers

Address	Register	Bit	Access	Default	Description
x0000	Word length	0	R/W/U	0	0: 16 bit word length 1: 32 bit word length
	Endianess	1	R/W/U	0	0: Little Endian 1: Big Endian
	High speed mode	4	R/W/U	1	0: Normal mode. RX and TX at different edges. 1: High speed mode. RX and TX on same edge (default).
	Interrupt polarity	5	R/W/U	1	0: Interrupt active polarity is low 1: Interrupt active polarity is high (default)
	Wake-up	7	R/W	0	A write of 1 will denote wake-up command from host to device. This will be followed by a F2 Interrupt from gSPI device to host, indicating device awake status.
x0001	Response delay	7:0	R/W/U	8'h04	Configurable read response delay in multiples of 8 bits

Table 16: gSPI Registers (Cont.)

Address	Register	Bit	Access	Default	Description
x0002	Status enable	0	R/W	1	0: no status sent to host after read/write 1: status sent to host after read/write
	Interrupt with status	1	R/W	0	0: do not interrupt if status is sent 1: interrupt host even if status is sent
	Response delay for all	2	R/W	0	0: response delay applicable to F1 read only 1: response delay applicable to all function read
x0003	Reserved	–	–	–	–
x0004	Interrupt register	0	R/W	0	Requested data not available; Cleared by writing a 1 to this location
		1	R	0	F2/F3 FIFO underflow due to last read
		2	R	0	F2/F3 FIFO overflow due to last write
		5	R	0	F2 packet available
		6	R	0	F3 packet available
		7	R	0	F1 overflow due to last write
		x0005	Interrupt register	5	R
6	R			0	F2 Interrupt
7	R			0	F3 Interrupt
x0006– x0007	Interrupt enable register	15:0	R/W/U	16'hE0E7	Particular Interrupt is enabled if a corresponding bit is set
x0008– x000B	Status register	31:0	R	32'h0000	Same as status bit definitions
x000C– x000D	F1 info register	0	R	1	F1 enabled
		1	R	0	F1 ready for data transfer
		13:2	R/U	12'h40	F1 max packet size
x000E– x000F	F2 info register	0	R/U	1	F2 enabled
		1	R	0	F2 ready for data transfer
		15:2	R/U	14'h800	F2 max packet size
x0010– x0011	F3 info register	0	R/U	1	F3 enabled
		1	R	0	F3 ready for data transfer
		15:2	R/U	14'h800	F3 max packet size
x0014– x0017	Test–Read only register	31:0	R	32'hFEED BEAD	This register contains a predefined pattern, which the host can read and determine if the gSPI interface is working properly.
x0018– x001B	Test–R/W register	31:0	R/W/U	32'h0000 0000	This is a dummy register where the host can write some pattern and read it back to determine if the gSPI interface is working properly.

Figure 32 shows the WLAN boot-up sequence from power-up to firmware download.

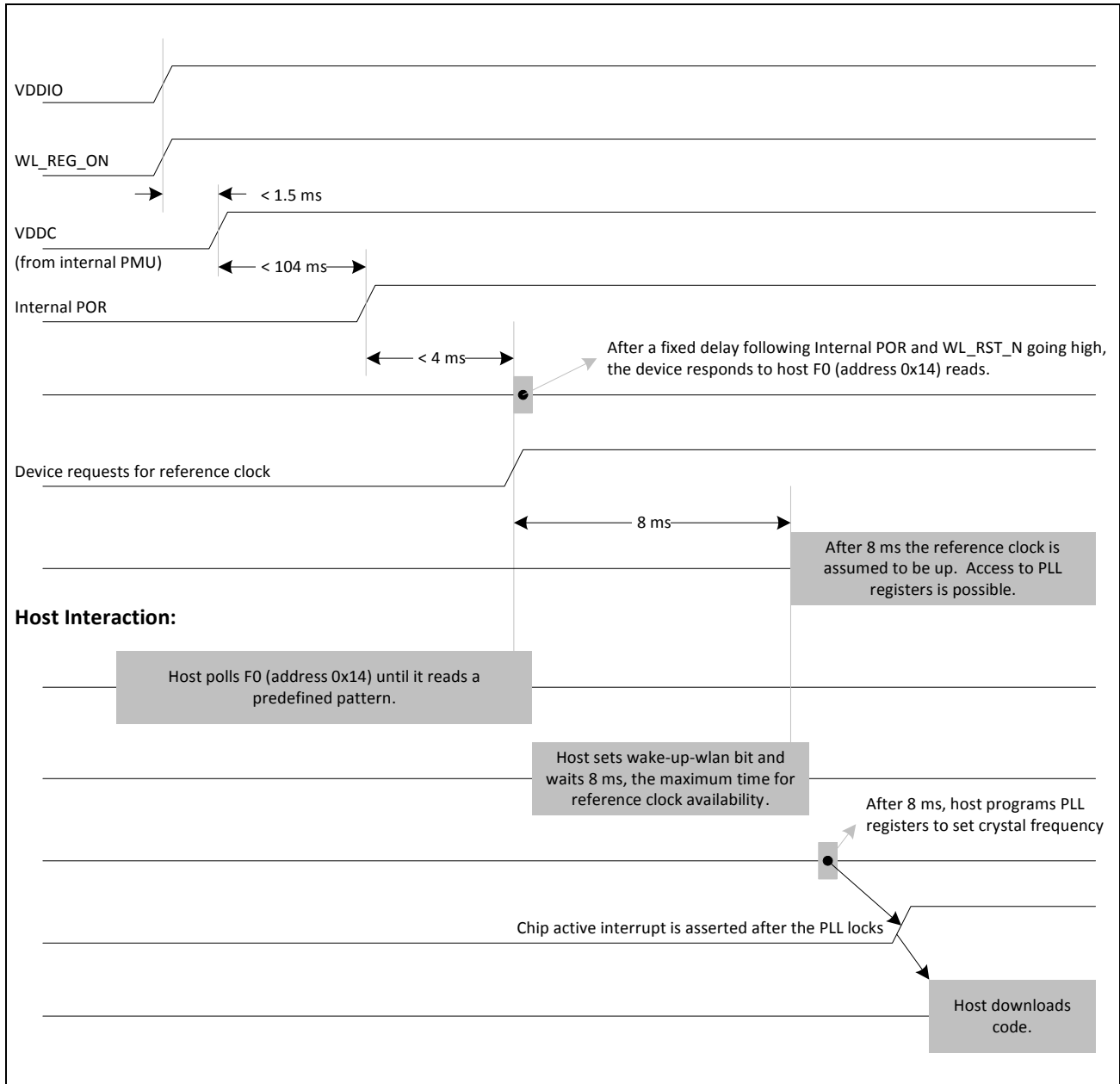

Figure 32: WLAN Boot-Up Sequence

Not Recommended for New Designs

HSIC Interface

As an alternative to SDIO, an HSIC host interface can be enabled using the strapping option pins strap_host_ifc_[3:1] (Table 19: “WLAN GPIO Functions and Strapping Options,” on page 112). HSIC is a simplified derivative of the USB2.0 interface designed to replace a standard USB PHY and cable for short distances (up to 10 cm) on board point-to-point connections. Using two signals, a bidirectional data strobe (STROBE) and a bidirectional DDR data signal (DATA), it provides high-speed serial 480 Mbps USB transfers that are 100% host driver compatible with traditional USB 2.0 cable-connected topologies.

Figure 33 shows the blocks in the HSIC device core.

A clock reference frequency of 37.4 MHz should always be used for HSIC mode.

Key features of HSIC include:

- High-speed 480 Mbps data rate only
- Source-synchronous serial interface using 1.2V LVCMOS signal levels
- No power consumed except when a data transfer is in progress
- Maximum trace length of 10 cm.
- No Plug-n-Play support, no hot attach/removal

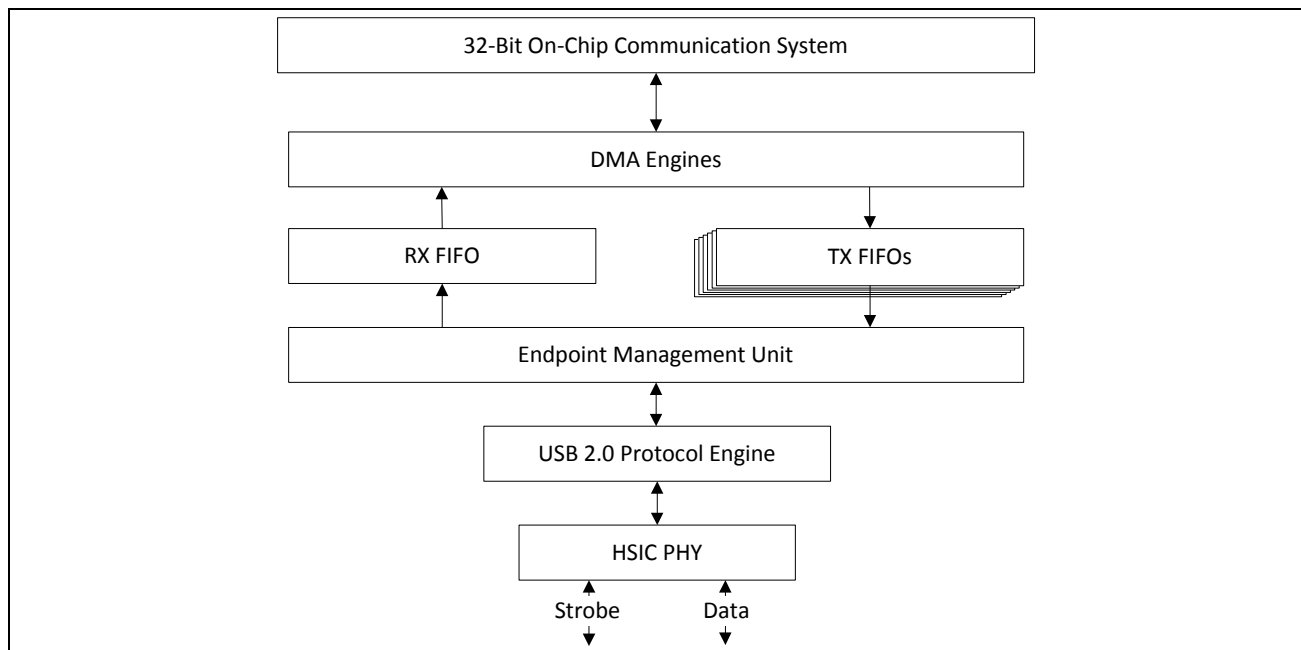

Figure 33: HSIC Device Block Diagram

Not Recommended for New Designs

Section 12: Wireless LAN MAC and PHY

MAC Features

The BCM4330 WLAN media access controller (MAC) supports features specified in the 802.11 base standard, and amended by 802.11n. The salient features are listed below:

- Transmission and reception of aggregated MPDUs (A-MPDU)
- Support for power management schemes, including WMM power-save, power-save multi-poll (PSMP) and multiphase PSMP operation
- Support for immediate ACK and Block-ACK policies
- Interframe space timing support, including RIFS
- Support for RTS/CTS and CTS-to-self frame sequences for protecting frame exchanges
- Back-off counters in hardware for supporting multiple priorities as specified in the WMM specification
- Timing synchronization function (TSF), network allocation vector (NAV) maintenance, and target beacon transmission time (TBTT) generation in hardware
- Hardware offload for AES-CCMP, legacy WPA TKIP, legacy WEP ciphers, WAPI, and support for key management
- Support for coexistence with Bluetooth and other external radios
- Programmable independent basic service set (IBSS) or infrastructure basic service set functionality
- Statistics counters for MIB support

MAC Description

The 4329 WLAN MAC is designed to support high-throughput operation with low-power consumption. It does so without compromising the Bluetooth coexistence policies, thereby enabling optimal performance over both networks. In addition, several power saving modes have been implemented that allow the MAC to consume very little power while maintaining network-wide timing synchronization. The architecture diagram of the MAC is shown in [Figure 34 on page 86](#).

The following sections provide an overview of the important modules in the MAC.

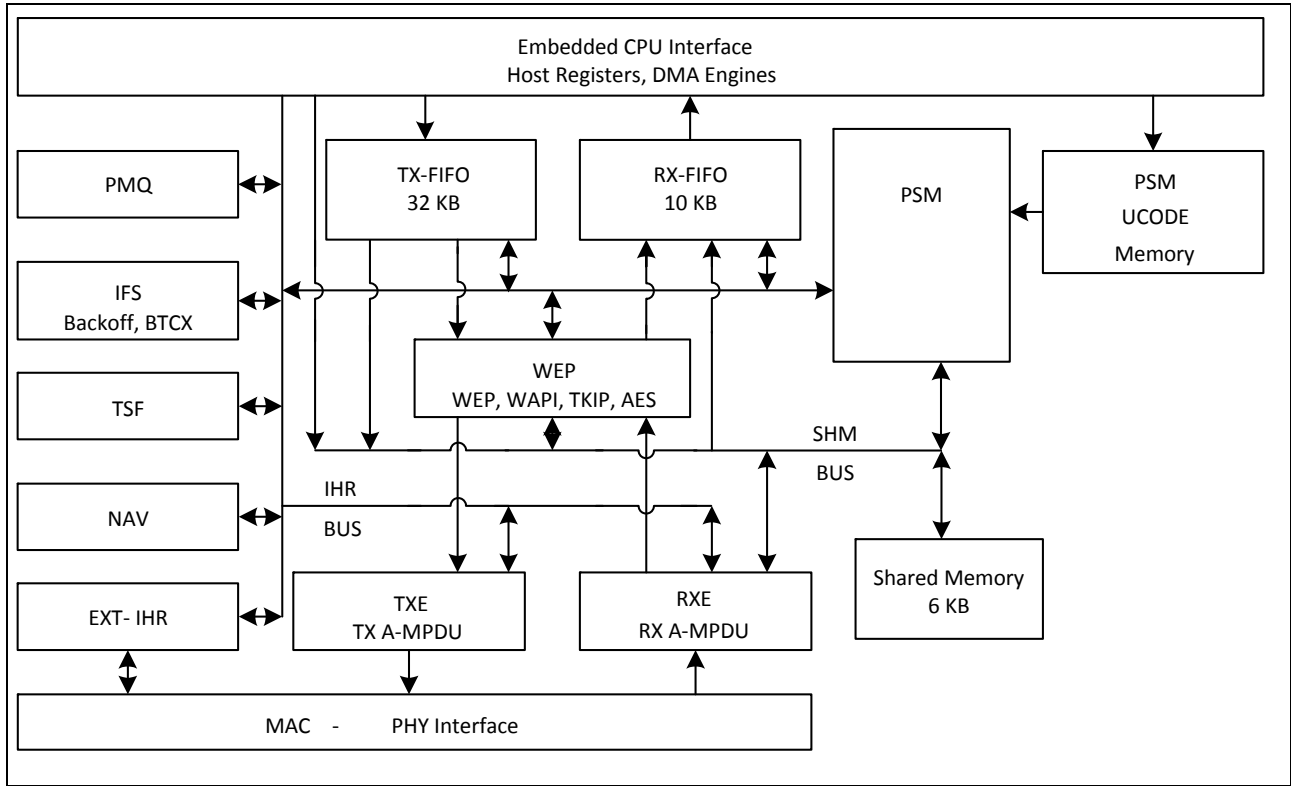

Figure 34: WLAN MAC Architecture

Not Recommended for New Designs

PSM

The programmable state machine (PSM) is a micro-coded engine, which provides most of the low-level control to the hardware, to implement the 802.11 specification. It is a microcontroller that is highly optimized for flow control operations, which are predominant in implementations of communication protocols. The instruction set and fundamental operations are simple and general, which allows algorithms to be optimized until very late in the design process. It also allows for changes to the algorithms to track evolving 802.11 specifications.

The PSM fetches instructions from the microcode memory. It uses the shared memory to obtain operands for instructions, as a data store, and to exchange data between both the host and the MAC data pipeline (via the SHM bus). The PSM also uses a scratchpad memory (similar to a register bank) to store frequently accessed and temporary variables.

The PSM exercises fine-grained control over the hardware engines, by programming internal hardware registers (IHR). These IHRs are co-located with the hardware functions they control, and are accessed by the PSM via the IHR bus.

The PSM fetches instructions from the microcode memory using an address determined by the program counter, instruction literal, or a program stack. For ALU operations the operands are obtained from shared memory, scratchpad, IHRs, or instruction literals, and the results are written into the shared memory, scratchpad, or IHRs.

There are two basic branch instructions: conditional branches and ALU based branches. To better support the many decision points in the 802.11 algorithms, branches can depend on either a readily available signals from the hardware modules (branch condition signals are available to the PSM without polling the IHRs), or on the results of ALU operations.

WEP

The wired equivalent privacy (WEP) engine encapsulates all the hardware accelerators to perform the encryption and decryption, and MIC computation and verification. The accelerators implement the following cipher algorithms: legacy WEP, WPA TKIP, WPA2 AES-CCMP.

The PSM determines, based on the frame type and association information, the appropriate cipher algorithm to be used. It supplies the keys to the hardware engines from an on-chip key table. The WEP interfaces with the TXE to encrypt and compute the MIC on transmit frames, and the RXE to decrypt and verify the MIC on receive frames.

TXE

The transmit engine (TXE) constitutes the transmit data path of the MAC. It coordinates the DMA engines to store the transmit frames in the TXFIFO. It interfaces with WEP module to encrypt frames, and transfers the frames across the MAC-PHY interface at the appropriate time determined by the channel access mechanisms.

The data received from the DMA engines are stored in transmit FIFOs. The MAC supports multiple logical queues to support traffic streams that have different QoS priority requirements. The PSM uses the channel access information from the IFS module to schedule a queue from which the next frame is transmitted. Once the frame is scheduled, the TXE hardware transmits the frame based on a precise timing trigger received from the IFS module.

The TXE module also contains the hardware that allows the rapid assembly of MPDUs into an A-MPDU for transmission. The hardware module aggregates the encrypted MPDUs by adding appropriate headers and pad delimiters as needed.

RXE

The receive engine (RXE) constitutes the receive data path of the MAC. It interfaces with the DMA engine to drain the received frames from the RXFIFO. It transfers bytes across the MAC-PHY interface and interfaces with the WEP module to decrypt frames. The decrypted data is stored in the RXFIFO.

The RXE module contains programmable filters that are programmed by the PSM to accept or filter frames based on several criteria such as receiver address, BSSID, and certain frame types.

The RXE module also contains the hardware required to detect A-MPDUs, parse the headers of the containers, and disaggregate them into component MPDUS.

IFS

The IFS module contains the timers required to determine interframe space timing including RIFS timing. It also contains multiple backoff engines required to support prioritized access to the medium as specified by WMM.

The interframe spacing timers are triggered by the cessation of channel activity on the medium, as indicated by the PHY. These timers provide precise timing to the TXE to begin frame transmission. The TXE uses this information to send response frames or perform transmit frame-bursting (RIFS or SIFS separated, as within a TXOP).

The backoff engines (for each access category) monitor channel activity, in each slot duration, to determine whether to continue or pause the backoff counters. When the backoff counters reach 0, the TXE gets notified, so that it may commence frame transmission. In the event of multiple backoff counters decrementing to 0 at the same time, the hardware resolves the conflict based on policies provided by the PSM.

The IFS module also incorporates hardware that allows the MAC to enter a low-power state when operating under the IEEE power save mode. In this mode, the MAC is in a suspended state with its clock turned off. A sleep timer, whose count value is initialized by the PSM, runs on a slow clock and determines the duration over which the MAC remains in this suspended state. Once the timer expires the MAC is restored to its functional state. The PSM updates the TSF timer based on the sleep duration ensuring that the TSF is synchronized to the network.

The IFS module also contains the PTA hardware that assists the PSM in Bluetooth coexistence functions.

TSF

The timing synchronization function (TSF) module maintains the TSF timer of the MAC. It also maintains the target beacon transmission time (TBTT). The TSF timer hardware, under the control of the PSM, is capable of adopting timestamps received from beacon and probe response frames in order to maintain synchronization with the network.

The TSF module also generates trigger signals for events that are specified as offsets from the TSF timer, such as uplink and downlink transmission times used in PSMP.

NAV

The network allocation vector (NAV) timer module is responsible for maintaining the NAV information conveyed through the duration field of MAC frames. This ensures that the MAC complies with the protection mechanisms specified in the standard.

The hardware, under the control of the PSM, maintains the NAV timer and updates the timer appropriately based on received frames. This timing information is provided to the IFS module, which uses it as a virtual carrier-sense indication.

MAC-PHY Interface

The MAC-PHY interface consists of a data path interface to exchange RX/TX data from/to the PHY. In addition, there is an programming interface, which can be controlled either by the host or the PSM to configure and control the PHY.

WLAN PHY Description

The BCM4330 WLAN Digital PHY is designed to comply with IEEE 802.11a/b/g/n single stream to provide wireless LAN connectivity supporting data rates from 1 Mbps to 72.2 Mbps for low power, high performance handheld applications.

The PHY has been designed to work with interference, radio nonlinearity, and impairments. It incorporates efficient implementations of the filters, FFT and Viterbi decoder algorithms. Efficient algorithms have been designed to achieve maximum throughput and reliability, including algorithms for carrier sense/rejection, frequency/phase/timing acquisition and tracking, channel estimation and tracking. The PHY receiver also contains a robust 11b demodulator. The PHY carrier sense has been tuned to provide high-throughput for 802.11g/11b hybrid networks with Bluetooth coexistence. It has also been designed for shared single antenna systems between WL and BT to support simultaneous Rx-Rx.

PHY Features

- Supports IEEE 802.11a, 11b, 11g, 11n single stream PHY standards
- 802.11n single-stream operation in 20 MHz channels
- Supports Optional Short GI and Green Field modes in Tx and Rx
- Supports optional space-time block code (STBC) receive of two space-time streams
- Supports 802.11h/k for worldwide operation
- Advanced algorithms for low power, enhanced sensitivity, range, and reliability
- Algorithms to improve performance in presence of Bluetooth
- Simultaneous Rx-Rx (WL-BT) architecture
- Automatic gain control scheme for blocking and non blocking application scenario for cellular applications.
- Closed loop transmit power control
- Digital RF chip calibration algorithms to handle CMOS RF chip non-idealities
- On-the-fly channel frequency and transmit power selection
- Supports per packet Rx antenna diversity
- Designed to meet FCC and other worldwide regulatory requirements

Not Recommended for New Designs

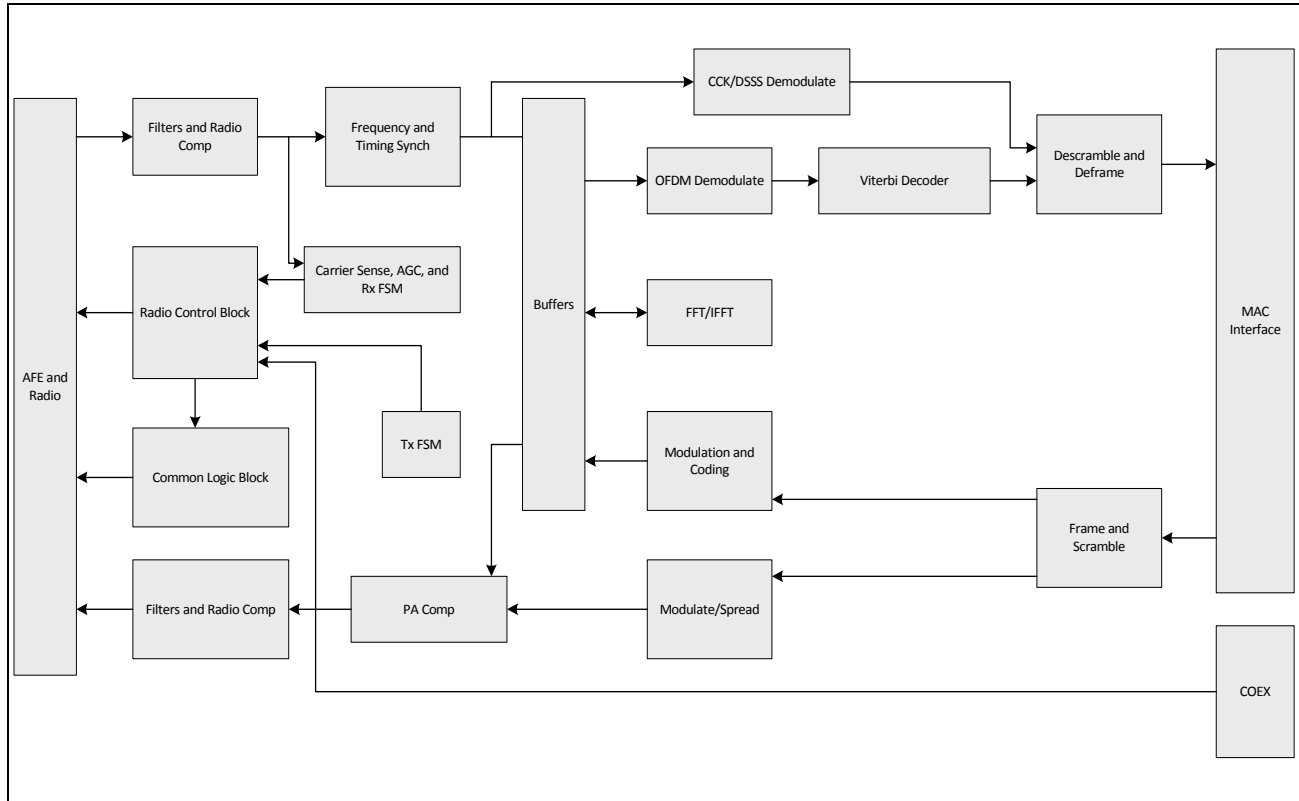

Figure 35: WLAN PHY Block Diagram

The PHY is capable of fully calibrating the RF front end to extract the highest performance. On power-up, the PHY performs a full suite of calibration to correct for IQ mismatch and local oscillator leakage. The PHY also performs periodic calibration to compensate for any temperature related drift thus maintaining high-performance over time. A closed loop transmit control algorithm maintains the output power to required level with capability control Tx power on a per packet basis.

One of the key feature of the PHY is two space-time stream receive capability. The STBC scheme can obtain diversity gains by using multiple transmit antennas in AP (Access Point) in a fading channel environment, without increasing the complexity at the STA. Details of the STBC receive is shown in the block diagram shown in [Figure 36 on page 92](#).

Not Recommended for New Designs

Section 13: WLAN Radio Subsystem

The BCM4330 includes an integrated dual-band WLAN RF transceiver that has been optimized for use in 2.4 GHz and 5 GHz Wireless LAN systems (but not both simultaneously). It has been designed to provide low-power, low-cost, and robust communications for applications operating in the globally available 2.4 GHz unlicensed ISM or 5 GHz U-NII bands. The transmit and receive sections include all on-chip filtering, mixing, and gain control functions.

Up to eight RF control signals are available to drive the external RF switches and support the addition of optional external power amplifiers and low noise amplifiers for either or both bands. See the reference board schematics for further details.

Receive Path

The BCM4330 has a wide dynamic range, direct conversion receiver. It employs high order on-chip channel filtering to ensure reliable operation in the noisy 2.4 GHz ISM band or the entire 5 GHz U-NII band. Control signals are available that can support the use of optional external low noise amplifiers (LNA), which can increase the receive sensitivity by several dB.

Transmit Path

Baseband data is modulated and upconverted to the 2.4 GHz ISM or 5-GHz U-NII bands, respectively. Linear on-chip power amplifiers are included, which are capable of delivering high output powers while meeting 802.11a/b/g/n specifications without the need for external PAs.

These PAs can be powered directly from VBAT, thereby eliminating the need for a separate PALDO. Closed-loop output power control is completely integrated.

Several spare RF control signals are available to support the addition of optional external power amplifiers for either or both bands.

Calibration

The BCM4330 features dynamic on-chip calibration, eliminating process variation across components. This enables the BCM4330 to be used in high-volume applications, because calibration routines are not required during manufacturing testing. These calibration routines are performed periodically in the course of normal radio operation. Examples of this automatic calibration are baseband filter calibration for optimum transmit and receive performance and LOFT calibration for leakage reduction. In addition, I/Q Calibration, R Calibration, and VCO Calibration are performed on-chip.

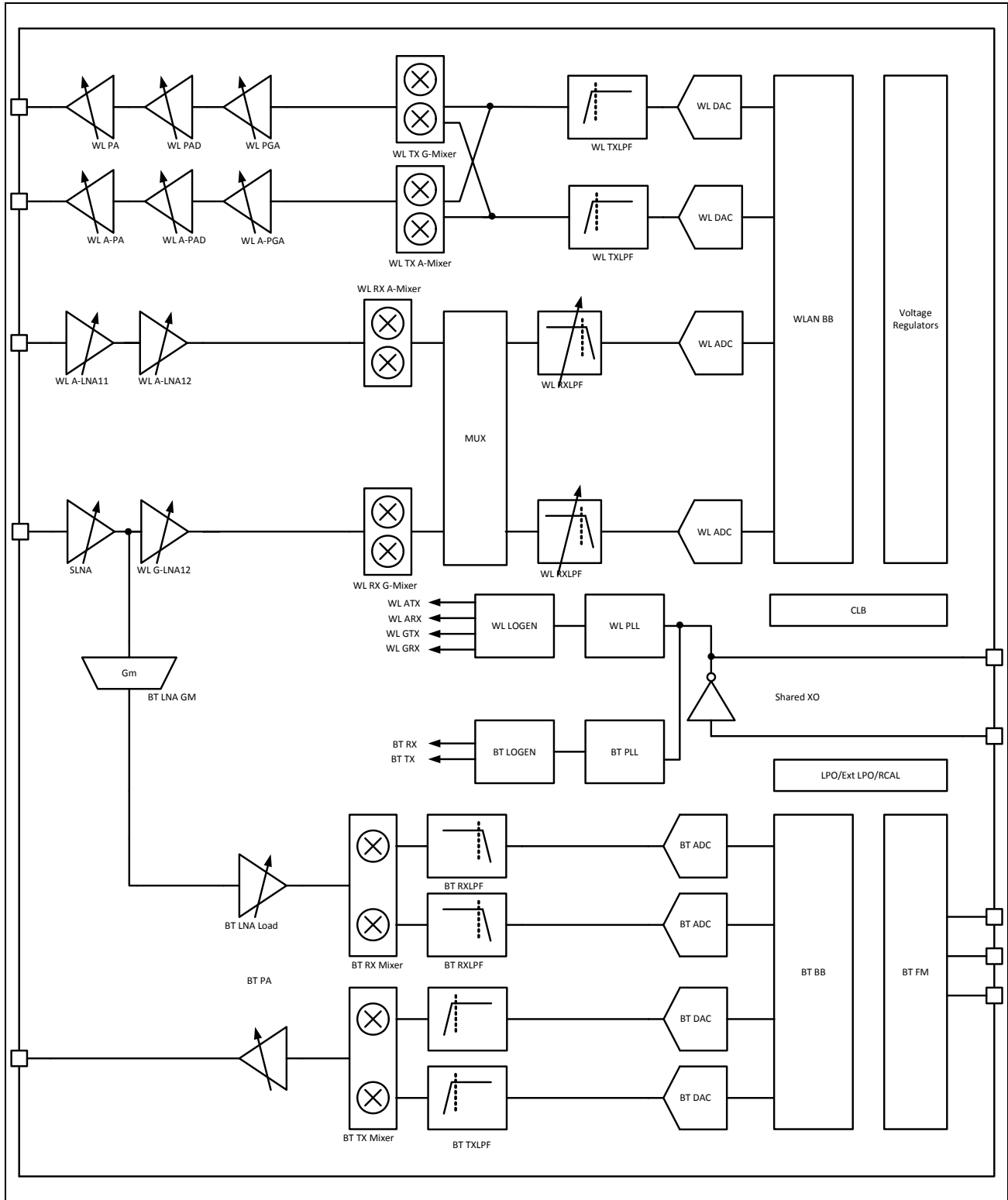

Figure 37: Radio Functional Block Diagram

Not Recommended for New Designs

Section 14: Pinout and Signal Descriptions

Signal Assignments

Figure 38 shows the FCFBGA ball map. Figure 39 shows the WLBGA ball map. Figure 40 shows the WLCSP bump map.

Table 17 on page 98 contains the WLCSP bump coordinates.

Table 18 on page 105 contains the signal description for all packages.

	1	2	3	4
A	WRF_RFIN_5G	WRF_RFOUT_5G	WRF_VDDPA_5G	WRF_VDDPA_2G
B	WRF_VDDLNA_1P2_5G	WRF_GNDLNA_5G	WRF_A_TSSI_IN	WRF_GNDPA_5G
C	WRF_LOGEN_A_VDD1P2	WRF_LOGEN_A_GND	WRF_ANA_GND	WRF_PADRV_VDD
D	WRF_VDD_VCOLDO_IN_1P8	WRF_VDDANA_1P2	WRF_VCOLDO_OUT_1P2	WRF_GPIO_OUT
E	WRF_TCXO_VDD	WRF_VCO_GND	WRF_VDDAFE_1P2	WRF_RES_EXT
F	WRF_XTAL_OP	WRF_TCXO_IN	WRF_AFE_GND	BT_PCM_IN
G	WRF_XTAL_ON	WRF_XTAL_GND	WRF_XTAL_VDD1P2	WL_GPIO_4
H	WL_GPIO_1	WL_GPIO_0	WL_GPIO_2	WL_GPIO_6
J	HSIC_AVDD12	WL_VDDC	WL_GPIO_3	VSSC
K	HSIC_STROBE	HSIC_AVSS	RF_SW_CTRL_7	VDDIO_RF
L	HSIC_DATA	HSIC_RREF	RF_SW_CTRL_2	RF_SW_CTRL_4
M	RF_SW_CTRL_5	RF_SW_CTRL_1	RF_SW_CTRL_0	RF_SW_CTRL_6

	5	6	7	8
A	WRF_RFOUT_2G	WRF_RFIN_2G	BT_PAVDD3P3	BT_RF
B	WRF_GNDPA_2G	WRF_VDDLNA_1P2_2G	BT_IFVDD1P2	BT_FEVSS
C	WRF_PADRV_GND	WRF_GNDLNA_2G	BT_IFVSS	BT_VSS
D	WRF_G_TSSI_IN	BT_UART_CTS_N	BT_CLK_REQ_IN	BT_CLK_REQ_POL
E	BT_PCM_CLK	BT_UART_RXD	BT_UART_TXD	BT_CLK_REQ_MODE
F	BT_PCM_SYNC	BT_UART_RTS_N	WL_VDDC	BT_VDDC
G	BT_PCM_OUT	VSSC	VSSC	VSSC
H	WL_GPIO_5	WL_VDDC	LPO	BT_I2S_WS
J	VSSC	VSSC	BT_VDDIO	BT_VDDC
K	RF_SW_CTRL_3	WL_VDDIO	VDD_ISLAND	BT_VDDC
L	JTAG_SEL	WL_VDDC	SDIO_DATA_0	SDIO_DATA_3
M	SDIO_DATA_1	SDIO_CLK	SDIO_CMD	SDIO_DATA_2

	9	10	11	12
A	BT_LNAVDD1P2	BT_VCOVDD1P2	FM_AOUT1	FM_AOUT2
B	BT_RFVSS	BT_PLLVDD1P2	FM_VDDAUDIO	FM_TX
C	BT_VCOVSS	FM_VSSAUDIO	FM_IFVDD1P2	FM_RFVDD_1P2
D	BT_PLLVSS	FM_PLLVSS	FM_RFVSS	FM_RXN
E	FM_VSS	FM_VDD2P5	FM_VSSVCO	FM_RXP
F	BT_GPIO_0	BT_RST_N	BT_TMO	BT_CLK_REQ_OUT
G	BT_I2S_CLK	BT_I2S_DI	BT_GPIO_4	BT_GPIO_2
H	BT_I2S_DO	BT_GPIO_5	BT_GPIO_1	BT_GPIO_3
J	EXT_SMPS_REQ	EXT_PWM_REQ	VOUT_3P1	VOUT_3P3
K	BT_REG_ON	PMU_AVSS	SR_VDDBAT2	SR_VDDBAT1
L	WL_REG_ON	VOUT_LNLD01	SR_VLX	SR_VDDBAT1
M	VOUT_CLDO	VIN_LDO	SR_PVSS	SR_VLX

Figure 38: 144-FCFBGA Ball Map (Top View)

Not Recommended for New Designs

	12	11	10	9	8	7	6	5	4	3	2	1	
A	FM_AOUT1	BT_VCOVDD1P2	BT_FEVSS	BT_RF	BT_PAVDD3P3	WRF_RFIN_2G	WRF_RFOUT_2G		WRF_VDDPA		WRF_RFOUT_5G		A
B	FM_AOUT2	BT_PLLVDD1P2	BT_RFVSS	BT_RFVDD1P2	BT_IFVDD1P2	WRF_VDDLNA_1P2_2G	WRF_PA_GND		WRF_PA_GND		WRF_PA_GND	WRF_RFIN_5G	B
C	FM_TX	FM_VSSAUDIO	BT_PLLVSS	BT_VSS	BT_IFVSS	WRF_GNDLNA_2G		WRF_GND	WRF_PADRV_GND	WRF_PADRV_VDD		WRF_ANA_GND	C
D	FM_RXN	FM_RXP	FM_VDDAUDIO	BT_GPIO_1	WL_GPIO_6	BT_CLK_REQ_IN	BT_UART_TXD	WL_GPIO_3	WRF_A_TSSI_IN	WRF_LOGEN_A_GND	WRF_LOGEN_A_VDD1P2	WRF_VDDANA_1P2	D
E	FM_RFVDD1P2	FM_RXVSS	FM_VDDPLL1P2	BT_CLK_REQ_MODE	BT_VDDC	WL_VDDC	BT_UART_RXD	WL_VSS_2	WRF_GPIO_OUT	WRF_RES_EXT		WRF_VDD_VCO_LDO_IN_1P8	E
F	FM_VDD2P5	FM_VSSVCO	FM_PLLVSS	BT_GPIO_0	BT_VSSC	BT_VDDIO	BT_UART_RTS_N	JTAG_SEL	WRF_AFE_GND	WRF_TCXO_VDD	WRF_VCO_LDO_OUT_1P2	WRF_VCO_GND	F
G	BT_CLK_REQ_OUT	BT_TM0	BT_RST_N		BT_GPIO_7	BT_I2S_DI	BT_UART_CTS_N	WL_GPIO_1	WRF_VDDAFE_1P2	WRF_TCXO_IN		WRF_XTAL_OP	G
H	BT_GPIO_4		BT_GPIO_2	BT_GPIO_3	BT_GPIO_6	BT_I2S_DO	BT_PCM_CLK	WL_GPIO_2	WL_GPIO_0	WRF_XTAL_VDD_1P2	WRF_XTAL_GND	WRF_XTAL_ON	H
J	VOUT_3P3	VOUT_3P1	EXT_PWM_REQ	BT_GPIO_5	WL_GPIO_4	LPO	BT_PCM_IN	BT_PCM_OUT	RF_SW_CTRL_5	RF_SW_CTRL_6	RF_SW_CTRL_1	HSIC_RREF	J
K	SR_VDDBAT1	SR_VDDBAT2	BT_REG_ON	EXT_SMPS_REQ	BT_VDDC	WL_VDDC	BT_PCM_SYNC	RF_SW_CTRL_0	RF_SW_CTRL_7	RF_SW_CTRL_4	WL_VSS_0	WL_VDDC	K
L	SR_VDDBAT1	PMU_AVSS	VOUT_LNLD01	WL_REG_ON	SDIO_DATA_3	SDIO_CMD	WL_GPIO_5	WL_VSS_1	RF_SW_CTRL_2	VDDIO_RF	HSIC_DATA	HSIC_AVDD12	L
M	SR_VLX	SR_PVSS	VIN_LDO	VOUT_CLDO	SDIO_DATA_1	SDIO_CLK	SDIO_DATA_0	SDIO_DATA_2	RF_SW_CTRL_3	WL_VDDO	HSIC_STROBE	HSIC_AVSS	M
	12	11	10	9	8	7	6	5	4	3	2	1	

Figure 39: 133-WLBGA Ball Map (bottom view)

Not Recommended for New Designs

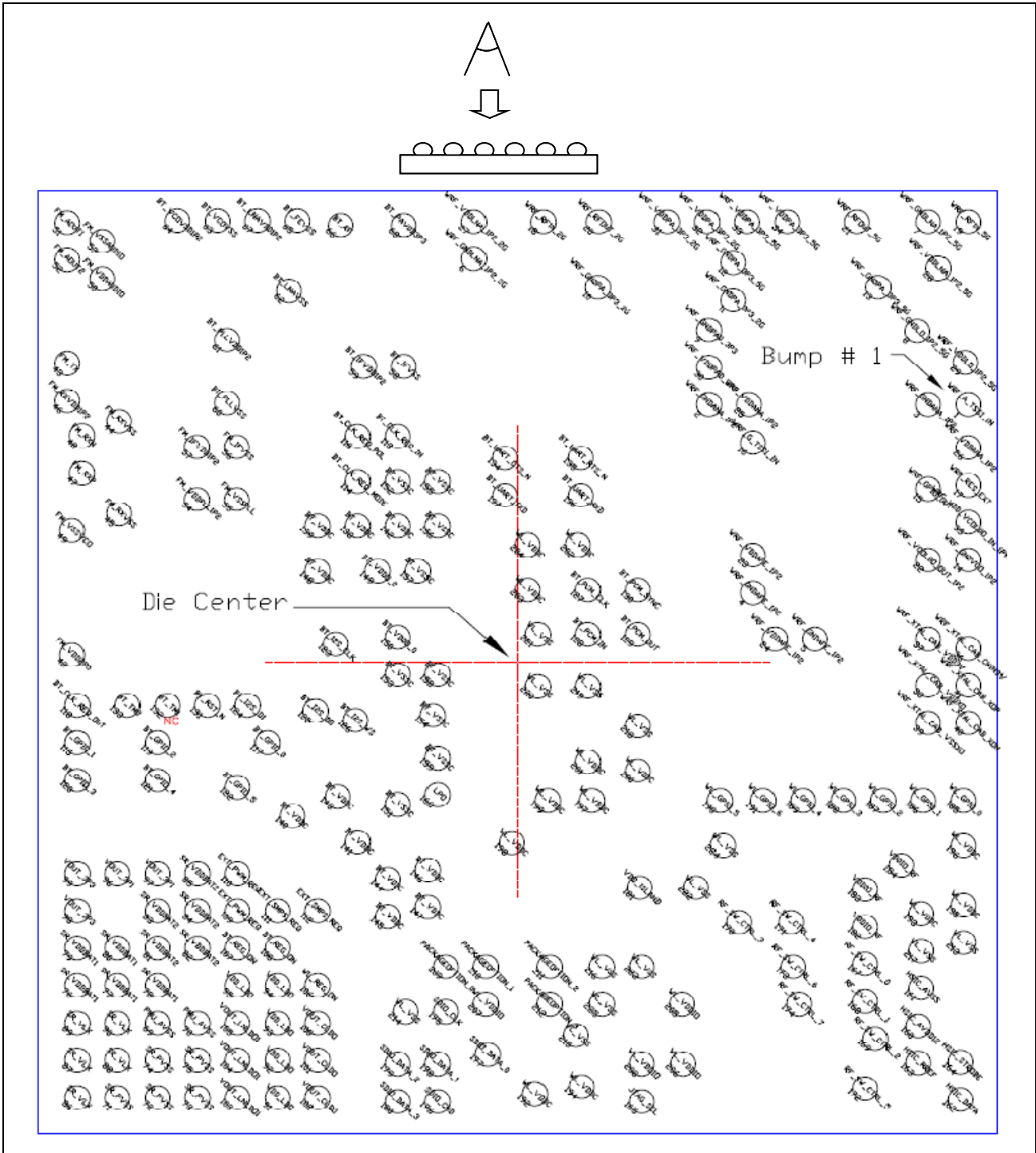

Figure 40: WLCSP 225-Bump Map (bottom view)

Not Recommended for New Designs

Table 17: WLCSP 225-Bump Coordinates

Bump Number	Signal	Bump Side View		Top Side View	
		0,0 is in the Center of the Die			
		X	Y	X	Y
1	WRF_A_TSSI_IN	2250	1490	-2250	1490
2	WRF_ANA_GND	955	1490	-955	1490
3	WRF_ANA_GND	2050	1490	-2050	1490
4	WRF_AFE_GND	1175	485	-1175	485
5	WRF_AFE_GND	1485	235	-1485	235
6	WRF_GNDLNA_2G	-220	2270	220	2270
7	WRF_GNDLNA_5G	2050	2470	-2050	2470
8	WRF_LOGEN_A_GND	1995	1885	-1995	1885
9	WRF_PADRV_GND	955	1890	-955	1890
10	WRF_GNDPA_2G	400	2120	-400	2120
11	WRF_GNDPA_2G	1075	2050	-1075	2050
12	WRF_GNDPA_5G	1075	2250	-1075	2250
13	WRF_GNDPA_5G	1800	2120	-1800	2120
14	WRF_VCO_GND	2250	660	-2250	660
15	WRF_GPIO_OUT	2050	1040	-2050	1040
16	WRF_G_TSSI_IN	1175	1285	-1175	1285
17	WRF_RES_EXT	2250	1060	-2250	1060
18	WRF_RFIN_2G	128	2470	-128	2470
19	WRF_RFIN_5G	2250	2470	-2250	2470
20	WRF_RFOUT_2G	404	2470	-404	2470
21	WRF_RFOUT_5G	1693	2470	-1693	2470
22	WRF_VCOLDO_OUT_1P2	2050	660	-2050	660
23	WRF_VDDAFE_1P2	1175	685	-1175	685
24	WRF_VDDAFE_1P2	1285	235	-1285	235
25	WRF_VDDANA_1P2	1155	1490	-1155	1490
26	WRF_LOGEN_A_VDD1P2	2250	1260	-2250	1260
27	WRF_VDDLNA_1P2_2G	-220	2470	220	2470
28	WRF_VDDLNA_1P2_5G	2100	2220	-2100	2220
29	WRF_VDDLLO_1P2_5G	2235	1715	-2235	1715
30	WRF_PADRV_VDD	955	1690	-955	1690
31	WRF_VDDPA_2G	745	2470	-745	2470
32	WRF_VDDPA_2G	945	2470	-945	2470
33	WRF_VDDPA_5G	1145	2470	-1145	2470

Not Recommended for New Designs

Table 17: WLCSP 225-Bump Coordinates (Cont.)

Bump Number	Signal	Bump Side View		Top Side View	
		0,0 is in the Center of the Die			
		X	Y	X	Y
34	WRF_VDDPA_5G	1345	2470	-1345	2470
35	WRF_VDD_VCOLDO_IN_1P8	2250	860	-2250	860
36	WRF_TCXO_IN	2250	186	-2250	186
37	WRF_TCXO_VDD	2050	235	-2050	235
38	WRF_XTAL_VDD1P2	2050	-14	-2050	-14
39	WRF_XTAL_GND	2050	-214	-2050	-214
40	WRF_XTAL_ON	2250	-214	-2250	-214
41	WRF_XTAL_OP	2250	-14	-2250	-14
42	FM_VDD2P5	-2227	151	2227	151
43	FM_TX	-2250	1711	2250	1711
44	FM_RXVSS	-1991	1400	1991	1400
45	FM_RXVSS	-1991	906	1991	906
46	FM_RFVDD1P2	-2250	1511	2250	1511
47	FM_RXP	-2177	1123	2177	1123
48	FM_RXN	-2177	1323	2177	1323
49	FM_VSSVCO	-2227	817	2227	817
50	FM_VDDAUDIO	-2076	2165	2076	2165
51	FM_AOUT1	-2250	2465	2250	2465
52	FM_AOUT2	-2250	2265	2250	2265
53	FM_VSSAUDIO	-2076	2365	2076	2365
54	FM_VDDPLL1P2	-1603	983	1603	983
55	FM_PLLVSS	-1403	983	1403	983
56	FM_IFVSS	-1403	1263	1403	1263
57	FM_IFVDD1P2	-1603	1263	1603	1263
58	BT_IFVSS	-570	1695	570	1695
59	BT_IFVDD1P2	-770	1695	770	1695
60	BT_PLLVSS	-1452	1499	1452	1499
61	BT_PLLVDD1P2	-1452	1837	1452	1837
62	BT_LNAVSS	-1143	2101	1143	2101
63	BT_VCOVSS	-1500	2475	1500	2475
64	BT_VCOVDD1P2	-1700	2475	1700	2475
65	BT_FEVSS	-1100	2475	1100	2475
66	BT_RF	-885	2452	885	2452
67	BT_LNAVDD1P2	-1300	2475	1300	2475

Not Recommended for New Designs

Table 17: WLCSP 225-Bump Coordinates (Cont.)

Bump Number	Signal	Bump Side View		Top Side View	
		0,0 is in the Center of the Die			
		X	Y	X	Y
68	BT_PAVDD3P3	-570	2452	570	2452
69	PMU_AVSS	-1800	-1820	1800	-1820
70	PMU_AVSS	-1600	-1820	1600	-1820
71	SR_PVSS	-2000	-2220	2000	-2220
72	SR_PVSS	-1800	-2220	1800	-2220
73	SR_PVSS	-1600	-2220	1600	-2220
74	SR_PVSS	-1800	-2020	1800	-2020
75	SR_PVSS	-1600	-2020	1600	-2020
76	SR_VDDBAT1	-2200	-1620	2200	-1620
77	SR_VDDBAT1	-2000	-1620	2000	-1620
78	SR_VDDBAT1	-1800	-1620	1800	-1620
79	SR_VDDBAT1	-2200	-1420	2200	-1420
80	SR_VDDBAT1	-2000	-1420	2000	-1420
81	SR_VDDBAT2	-1800	-1420	1800	-1420
82	SR_VDDBAT2	-1600	-1420	1600	-1420
83	SR_VDDBAT2	-1800	-1220	1800	-1220
84	SR_VDDBAT2	-1600	-1220	1600	-1220
85	SR_VDDBAT2	-1600	-1020	1600	-1020
86	SR_VLX	-2200	-2220	2200	-2220
87	SR_VLX	-2200	-2020	2200	-2020
88	SR_VLX	-2000	-2020	2000	-2020
89	SR_VLX	-2200	-1820	2200	-1820
90	SR_VLX	-2000	-1820	2000	-1820
91	VDD_LDO	-1200	-2220	1200	-2220
92	VDD_LDO	-1200	-2020	1200	-2020
93	VDD_LDO	-1200	-1820	1200	-1820
94	VDD_LDO	-1200	-1620	1200	-1620
95	VDD_LDO	-1400	-1620	1400	-1620
96	VOUT_3P1	-2000	-1020	2000	-1020
97	VOUT_3P1	-1800	-1020	1800	-1020
98	VOUT_3P3	-2200	-1220	2200	-1220
99	VOUT_3P3	-2200	-1020	2200	-1020
100	VOUT_CLDO	-1000	-1820	1000	-1820
101	VOUT_CLDO	-1000	-2020	1000	-2020

Not Recommended for New Designs

Table 17: WLCSP 225-Bump Coordinates (Cont.)

Bump Number	Signal	Bump Side View		Top Side View	
		0,0 is in the Center of the Die			
		X	Y	X	Y
102	VOUT_CLDO	-1000	-2220	1000	-2220
103	VOUT_LNLDO1	-1400	-2220	1400	-2220
104	VOUT_LNLDO1	-1400	-2020	1400	-2020
105	VOUT_LNLDO1	-1400	-1820	1400	-1820
106	WL_REG_ON	-1000	-1620	1000	-1620
107	BT_REG_ON	-1400	-1420	1400	-1420
108	BT_REG_ON	-1200	-1420	1200	-1420
109	EXT_PWM_REQ	-1400	-1220	1400	-1220
110	EXT_PWM_REQ	-1400	-1020	1400	-1020
111	EXT_SMPS_REQ	-1200	-1220	1200	-1220
112	EXT_SMPS_REQ	-1000	-1220	1000	-1220
113	BT_CLK_REQ_IN	-600	1320	600	1320
114	BT_CLK_REQ_MODE	-800	1080	800	1080
115	BT_GPIO_1	-2200	-320	2200	-320
116	BT_CLK_REQ_POL	-800	1320	800	1320
117	BT_GPIO_0	-1250	-320	1250	-320
118	BT_CLK_REQ_OUT	-2200	-120	2200	-120
119	BT_GPIO_2	-1800	-320	1800	-320
120	BT_GPIO_3	-2200	-520	2200	-520
121	BT_GPIO_4	-1800	-520	1800	-520
122	BT_GPIO_5	-1400	-560	1400	-560
123	BT_I2S_CLK	-910	210	910	210
124	BT_I2S_DI	-1350	-120	1350	-120
125	BT_I2S_DO	-1010	-150	1010	-150
126	BT_I2S_WS	-810	-200	810	-200
127	BT_PCM_CLK	350	500	-350	500
128	BT_PCM_IN	350	260	-350	260
129	BT_PCM_OUT	600	260	-600	260
130	BT_PCM_SYNC	600	500	-600	500
131	BT_RST_N	-1550	-120	1550	-120
132	BT_TM1	-1750	-120	1750	-120
133	BT_TM0	-1950	-120	1950	-120
134	BT_UART_CTS_N	-65	1205	65	1205
135	BT_UART_RTS_N	315	1205	-315	1205

Table 17: WLCSP 225-Bump Coordinates (Cont.)

Bump Number	Signal	Bump Side View		Top Side View	
		0,0 is in the Center of the Die			
		X	Y	X	Y
136	BT_UART_RXD	315	1005	-315	1005
137	BT_UART_TXD	-65	1005	65	1005
138	BT_VDDC	-800	840	800	840
139	BT_VDDC	-1000	840	1000	840
140	BT_VDDC	-1125	-710	1125	-710
141	BT_VDDC	-800	-850	800	-850
142	BT_VDDC	-600	840	600	840
143	BT_VDDC	-900	-610	900	-610
144	BT_VDDC	-650	-1050	650	-1050
145	BT_VDDC	-650	-1250	650	-1250
146	BT_VDDC	-450	-1000	450	-1000
147	BT_VDDC	-450	-1200	450	-1200
148	BT_VDDC	-1000	600	1000	600
149	BT_VDDIO	-700	600	700	600
150	BT_VDDIO	-600	245	600	245
151	BT_VSSC	-600	-650	600	-650
152	BT_VSSC	-600	1080	600	1080
153	BT_VSSC	-600	45	600	45
154	BT_VSSC	-425	-175	425	-175
155	BT_VSSC	-400	1080	400	1080
156	BT_VSSC	-400	840	400	840
157	BT_VSSC	-500	600	500	600
158	BT_VSSC	-400	45	400	45
159	BT_VSSC	-400	-400	400	-400
160	HSIC_AVDD12	2000	-1835	-2000	-1835
161	HSIC_AVSS	2015	-1635	-2015	-1635
162	HSIC_DATA	2210	-2230	-2210	-2230
163	HSIC_RREF	2000	-2035	-2000	-2035
164	HSIC_STROBE	2210	-2030	-2210	-2030
165	JTAG_SEL	620	-2240	-620	-2240
166	LPO	-400	-600	400	-600
167	RF_SW_CTRL_0	1735	-1505	-1735	-1505
168	RF_SW_CTRL_1	1735	-1705	-1735	-1705
169	RF_SW_CTRL_2	1785	-1905	-1785	-1905

Not Recommended for New Designs

Table 17: WLCSP 225-Bump Coordinates (Cont.)

Bump Number	Signal	Bump Side View		Top Side View	
		0,0 is in the Center of the Die			
		X	Y	X	Y
170	RF_SW_CTRL_3	1105	-1280	-1105	-1280
171	RF_SW_CTRL_4	1365	-1280	-1365	-1280
172	RF_SW_CTRL_5	1735	-2170	-1735	-2170
173	RF_SW_CTRL_6	1375	-1520	-1375	-1520
174	RF_SW_CTRL_7	1405	-1720	-1405	-1720
175	SDIO_CLK	-360	-1760	360	-1760
176	SDIO_CMD	-400	-2240	400	-2240
177	SDIO_DATA_0	-150	-1990	150	-1990
178	SDIO_DATA_1	-400	-2040	400	-2040
179	SDIO_DATA_2	-600	-2040	600	-2040
180	SDIO_DATA_3	-600	-2240	600	-2240
181	VDD_ISLAND	610	-1095	-610	-1095
182	VDDIO_RF	1735	-1305	-1735	-1305
183	VDDIO_RF	1735	-1105	-1735	-1105
184	VDDIO_RF	1915	-975	-1915	-975
185	WL_GPIO_0	2225	-630	-2225	-630
186	WL_GPIO_1	2025	-630	-2025	-630
187	WL_GPIO_2	1825	-630	-1825	-630
188	WL_GPIO_3	1625	-630	-1625	-630
189	WL_GPIO_4	1425	-630	-1425	-630
190	WL_GPIO_5	1010	-630	-1010	-630
191	WL_GPIO_6	1225	-630	-1225	-630
192	WL_VDDC	85	-2200	-85	-2200
193	WL_VDDC	2015	-1235	-2015	-1235
194	WL_VDDC	320	-2160	-320	-2160
195	WL_VDDC	2225	-1190	-2225	-1190
196	WL_VDDC	2225	-870	-2225	-870
197	WL_VDDC	370	-630	-370	-630
198	WL_VDDC	-30	-855	30	-855
199	WL_VDDC	150	-630	-150	-630
200	WL_VDDC	600	-470	-600	-470
201	WL_VDDC	350	-420	-350	-420
202	WL_VDDC	300	740	-300	740
203	WL_VDDC	50	500	-50	500

Not Recommended for New Designs

Table 17: WLCSP 225-Bump Coordinates (Cont.)

Bump Number	Signal	Bump Side View		Top Side View	
		0,0 is in the Center of the Die			
		X	Y	X	Y
204	WL_VDDC	50	740	-50	740
205	WL_VDDIO	820	-1720	-820	-1720
206	WL_VDDIO	825	-2040	-825	-2040
207	WL_VDDIO	-160	-1720	160	-1720
208	WL_VDDIO	620	-2040	-620	-2040
209	PACKAGEOPTION_0	-360	-1520	360	-1520
210	PACKAGEOPTION_1	-160	-1520	160	-1520
211	PACKAGEOPTION_2	160	-1520	-160	-1520
212	PACKAGEOPTION_3	160	-1720	-160	-1720
213	WL_VSS	2225	-1390	-2225	-1390
214	WL_VSS	-560	-1760	560	-1760
215	WL_VSS	290	-1885	-290	-1885
216	WL_VSS	420	-1520	-420	-1520
217	WL_VSS	2015	-1435	-2015	-1435
218	WL_VSS	600	-230	-600	-230
219	WL_VSS	350	-20	-350	-20
220	WL_VSS	100	-20	-100	-20
221	WL_VSS	100	260	-100	260
222	WL_VSS	890	-1095	-890	-1095
223	WL_VSS	620	-1520	-620	-1520
224	WL_VSS	1025	-870	-1025	-870
225	WL_VSS	420	-1720	-420	-1720

Not Recommended for New Designs

Table 18: FCFBGA, WLBGA, and WLCSP Signal Descriptions

Ball#		Bump#		Signal Name	Type	Description
FCFBGA	WLBGA	WLCSP				
WLAN RF Interface						
E4	E3	17		WRF_RES_EXT	I	Connect to external 15 kΩ (1%) to ground
A1	B1	19		WRF_RFIN_5G	I	WLAN 802.11a internal LNA Rx input
A2	A2	21		WRF_RFOUT_5G	O	WLAN 802.11a internal power amplifier output
A6	A7	18		WRF_RFIN_2G	I	WLAN 802.11b/g and BT shared LNA RX input
A5	A6	20		WRF_RFOUT_2G	O	WLAN 802.11b/g internal power amplifier output
B3	D4	1		WRF_A_TSSI_IN	I	TSSI_11a-band (see reference schematics)
D5	–	16		WRF_G_TSSI_IN	I	TSSI_11g-band (see reference schematics). For the WLBGA package, WRF_GPIO_OUT can be used as an 11g-band TSSI input.
RF Control Lines						
M3	K5	167		RF_SW_CTRL_0	O	Programmable RF switch control lines. The control lines are programmable via the driver and NVRAM file. Contact Broadcom for details.
M2	J2	168		RF_SW_CTRL_1	O	
L3	L4	169		RF_SW_CTRL_2	O	
K5	M4	170		RF_SW_CTRL_3	O	
L4	K3	171		RF_SW_CTRL_4	O	
M1	J4	172		RF_SW_CTRL_5	O	
M4	J3	173		RF_SW_CTRL_6	O	
K3	K4	174		RF_SW_CTRL_7	O	
Integrated LDOs						
L10	L10	103–105		VOUT_LNLDO1	O	Output of low noise LNLDO1
M9	M9	100–102		VOUT_CLDO	O	Output of core LDO
D1	E1	35		WRF_VDD_VCOLDO_IN_1P8	I	Input to VCOLD0
D3	F2	22		WRF_VCOLDO_OUT_1P2	O	Output of VCOLD0
M10	M10	91–95		VIN_LDO	I	Input supply pin to LDO
J11	J11	96–97		VOUT_3P1	O	LDO3p1 output (+2.5V output by default)
J12	J12	98–99		VOUT_3P3	O	LDO3p3 output (+3.3V output by default)

Not Recommended for New Designs

Table 18: FCBGA, WLBGA, and WLCSP Signal Descriptions (Cont.)

Ball#		Bump#		Signal Name	Type	Description
FCBGA	WLBGA	WLCSP				
Integrated Switching Regulators						
L12, K12	L12, K12	76–80		SR_VDDBAT1	I	Buck regulator: Battery Voltage Input
K11	K11	81–85		SR_VDDBAT2	I	
L11, M12	M12	86–90		SR_VLX	O	Core buck regulator: output to inductor
WLAN SDIO Bus Interface						
L7	M6	177		SDIO_DATA_0	I/O	SDIO data line 0
M5	M8	178		SDIO_DATA_1	I/O	SDIO data line 1
M8	M5	179		SDIO_DATA_2	I/O	SDIO data line 2
L8	L8	180		SDIO_DATA_3	I/O	SDIO data line 3
M6	M7	175		SDIO_CLK	I	SDIO clock
M7	L7	176		SDIO_CMD	I/O	SDIO command line
JTAG Interface						
L5	F5	165		JTAG_SEL	I	JTAG selection pin (pulled HIGH by default)
–	–	–		TCK	I	These JTAG signals can be enabled by software on pins WL_GPIO[1:5].
–	–	–		TDI	I	
–	–	–		TDO	I	TMS WL_GPIO1
–	–	–		TMS	I	TCK WL_GPIO2
–	–	–				TDI WL_GPIO3
–	–	–				TDO WL_GPIO4
–	–	–				TRST_L WL_GPIO5
HSIC Interface						
K1	M2	164		HSIC_STROBE	I/O	HSIC bidirectional data strobe signal. HSIC terminations are built in, external resistors are not needed. On SDIO designs this pin should not be connected.
L1	L2	162		HSIC_DATA	I/O	HSIC bidirectional DDR data signal. HSIC terminations are built in, external resistors are not needed. On SDIO designs this pin should not be connected.
L2	J1	163		HSIC_RREF	I	HSIC bias pin. Connect to ground via a 49.9 Ohm series resistor. On SDIO designs this pin should not be connected.
Clocks						
F1	G1	41		WRF_XTAL_OP	I	Crystal oscillator input
G1	H1	40		WRF_XTAL_ON	O	Crystal oscillator output
F2	G3	36		WRF_TCXO_IN	I	External TCXO input

Table 18: FCFBGA, WLBGA, and WLCSP Signal Descriptions (Cont.)

Ball#		Bump#		Signal Name	Type	Description
FCFBGA	WLBGA	WLCSP				
H7	J7	166		LPO	I	Input for external low-power clock
WLAN GPIO						
D4	E4	15		WRF_GPIO_OUT	O	Auxiliary RF I/O (see reference schematics). For the WLBGA package, WRF_GPIO_OUT can be used as an 11g-band TSSI signal.
H2	H4	185		WL_GPIO_0	I/O	WLAN general interface pins. These pins are high-impedance on power up and reset. Subsequently, they become inputs or outputs through software control. These pins have programmable pull-up/down. WL_GPIO_0 may be configured by software to function as SDIO_Host_Wake. WL_GPIO[1:5] may be enabled as JTAG signals (see “JTAG Interface” on page 73). WL_GPIO[3:4] may be configured by software to function as UART_RX and UART_TX. WL_GPIO[1:5] can be configured as external coexistence interface pins (see “External Coexistence Interface” on page 73).
H1	G5	186		WL_GPIO_1	I/O	
H3	H5	187		WL_GPIO_2	I/O	
J3	D5	188		WL_GPIO_3	I/O	
G4	J8	189		WL_GPIO_4	I/O	
H5	L6	190		WL_GPIO_5	I/O	
H4	D8	191		WL_GPIO_6	I/O	
FM Transceiver						
A11	A12	51		FM_AOUT1	O	FM analog audio output channel 1
A12	B12	52		FM_AOUT2	O	FM analog audio output channel 2
B12	C12	43		FM_TX	O	FM radio RF output antenna port
E12	D11	47		FM_RXP	I	FM radio RF antenna port
D12	D12	48		FM_RXN	I	FM radio RF antenna port
Bluetooth UART						
E6	E6	136		BT_UART_RXD	I/O	Bluetooth UART signal input. Serial data input for the HCI UART Interface.
E7	D6	137		BT_UART_TXD	I/O	Bluetooth UART signal output. Serial data input for the HCI UART Interface.
F6	F6	135		BT_UART_RTS_N	I/O	Bluetooth UART REquest to Send. Active-low request-to-send signal for the HCI UART interface.
D6	G6	134		BT_UART_CTS_N	I/O	Bluetooth UART Clear to Send. Active-low clear-to-send signal for the HCI UART interface.

Table 18: FCFBGA, WLBGA, and WLCSP Signal Descriptions (Cont.)

Ball#		Bump#		Signal Name	Type	Description
FCFBGA	WLBGA	WLCSP				
Bluetooth Test Mode						
F11	G11	133		BT_TM0	I	Bluetooth test mode pin (no connect)
–	–	132		BT_TM1	I	Bluetooth test mode pin (no connect)
Bluetooth						
A8	A9	66		BT_RF	O	Bluetooth PA output
D7	D7	113		BT_CLK_REQ_IN	I	Reference clock request
D8	–	116		BT_CLK_REQ_POL	I	BT Request clock power on reset
E8	E9	114		BT_CLK_REQ_MODE	I	External reference clock request mode. When BT_CLK_REQ_OUT is used as a HIGH asserting output (by default) to control an external TCXO, this BT_CLK_REQ_MODE pin must be connected to ground.
F12	G12	118		BT_CLK_REQ_OUT	O	Bluetooth clock request out
Bluetooth/FM I²S						
G9	H8	123		BT_I2S_CLK	I	Bluetooth I ² S pins
G10	G7	124		BT_I2S_DI	I/O	
H8	G8	126		BT_I2S_WS	I/O	
H9	H7	125		BT_I2S_DO	I/O	
Bluetooth PCM						
E5	H6	127		BT_PCM_CLK	I/O	PCM clock, can be master (output) or slave (input)
F4	J6	128		BT_PCM_IN	I/O	PCM data input
G5	J5	129		BT_PCM_OUT	I/O	PCM data output
F5	K6	130		BT_PCM_SYNC	I/O	PCM sync signal, can be master (output) or slave (input)
Bluetooth GPIO						
F9	F9	117		BT_GPIO_0	I/O	Bluetooth general interface pins. These pins are high-impedance on power up and reset. Subsequently, they become inputs or outputs through software control. These pins have programmable pull-up/down.
H11	D9	115		BT_GPIO_1	I/O	
G12	H10	119		BT_GPIO_2	I/O	
H12	H9	120		BT_GPIO_3	I/O	
G11	H12	121		BT_GPIO_4	I/O	
H10	J9	122		BT_GPIO_5	I/O	

Table 18: FCFBGA, WLBGA, and WLCSP Signal Descriptions (Cont.)

Ball#		Bump#		Signal Name	Type	Description
FCFBGA	WLBGA	WLCSP				
Miscellaneous						
L9	L9	106		WL_REG_ON	I	Used by PMU (OR-gated with BT_REG_ON) to power up or power down the internal BCM4330 regulators used by the WLAN section. This pin is also a low-asserting reset for WLAN only (Bluetooth is not affected by this pin). Logic High Level: 1.08V–3.6V 200k pull-down resistor included.
K9	K10	107–108		BT_REG_ON	I	Used by PMU (OR-gated with WL_REG_ON) to power up or power down internal BCM4330 regulators used by the BT/FM section. Logic High Level: 1.08V–3.6V 200k pull-down resistor included.
F10	G10	131		BT_RST_N	I	Low asserting reset for Bluetooth/FM only (WLAN is not affected by this pin).
J9	K9	111–112		EXT_SMPS_REQ	I	Auxiliary PMU control inputs (see “Reset Circuits” on page 31). These pins have 200k internal pull-down resistors and should be no-connect when not used. Logic High Level: 1.08V–3.6V
J10	J10	109–110		EXT_PWM_REQ	I	
Bluetooth Supplies						
A7	A8	68		BT_PAVDD3P3	I	3.3V Bluetooth internal PA power supply
–	B9	–		BT_RFVDD1P2	I	1.2V Bluetooth power supply
A9	–	67		BT_LNAVDD1P2	I	1.2V Bluetooth LNA power supply
A10	A11	64		BT_VCOVDD1P2	I	1.2V Bluetooth VCO power supply
B7	B8	59		BT_IFVDD1P2	I	1.2V Bluetooth IF block power supply
B10	B11	61		BT_PLLVDD1P2	I	1.2V Bluetooth PLL power supply
F8, J8, K8	K8, E8	138–148		BT_VDDC	I	1.2V Bluetooth baseband core supply
WLAN Supplies						
A3	–	33, 34		WRF_VDDPA_5G	I	VDD power supply (from VBAT) for the internal 11a-band power amplifier
A4	–	31, 32		WRF_VDDPA_2G	I	VDD power supply (from VBAT) for the internal 11g-band power amplifier
–	A4	–		WRF_VDDPA	I	VDD power supply (from VBAT) for both internal power amplifiers
C4	C3	30		WRF_PADRV_VDD	I	VDD power supply (from VBAT) supply for the WLAN PA driver

Table 18: FCFBGA, WLBGA, and WLCSP Signal Descriptions (Cont.)

Ball#		Bump#	Signal Name	Type	Description
FCFBGA	WLBGA	WLCSP			
B1	–	28	WRF_VDDLNA_1P2_5G	I	1.2V supply for the 11a-band internal LNA: If the 5G band is not used, tie this supply pin to WRF_VDDLNA_1P2_2G.
B6	B7	27	WRF_VDDLNA_1P2_2G	I	1.2V supply for the 11g-band internal LNA
G3	H3	38	WRF_XTAL_VDD1P2	I	1.2V supply for the crystal oscillator circuit
E1	F3	37	WRF_TCXO_VDD	I	1.7V to 3.3V supply for the BCM4330 TCXO driver. To maintain a constant load on the WRF_TCXO_IN pin (even when power is removed from the BCM4330), connect this supply pin to a 1.7V to 3.3V supply that is always present. If not used, this pin must be connected to ground (see Section 3: “Frequency References,” on page 32).
C1	D2	29	WRF_LOGEN_A_VDD1P2	I	1.2V supply for WLAN PLL
E3	G4	23, 24	WRF_VDDAFE_1P2	I	1.2V supply for WLAN AFE
D2	D1	25–26	WRF_VDDANA_1P2	I	1.2V supply for WLAN ADC/DAC block
F7, H6, J2, L6	E7,K7,K1	192–204	WL_VDDC	I	1.2V supply for WLAN core
FM Transceiver Supplies					
C12	E12	46	FM_RFVDD1P2	I	1.2V FM transceiver power supply
C11	–	57	FM_IFVDD1P2	I	1.2V FM IF power supply
–	E10	54	FM_VDDPLL1P2	I	1.2V FM PLL power supply
E10	F12	42	FM_VDD2P5	I	2.5V FM power supply
B11	D10	50	FM_VDDAUDIO	I	FM audio power supply
Miscellaneous Supplies					
J1	L1	160	HSIC_AVDD12	I	1.2V HSIC power supply: on SDIO designs this pin should not be connected.
K4	L3	182–184	VDDIO_RF	I/O	RF I/O supply (3.3V)
K6	M3	205–208	WL_VDDIO	I	WLAN digital I/O supply (1.2V to 2.5V)
J7	F7	149–150	BT_VDDIO	I	BT digital I/O supply (1.2V to 2.5V)
–	–	212	PACKAGEOPTION_3	I	Connect to VDD
Ground					
C2	D3	8	WRF_LOGEN_A_GND	I	WLAN 11a-band LO ground
B4	–	12–13	WRF_GNDPA_5G	I	WLAN 11a-band PA ground
B5	–	10–11	WRF_GNDPA_2G	I	WLAN 11g-band PA ground

Table 18: FCFBGA, WLBGA, and WLCSP Signal Descriptions (Cont.)

Ball#		Bump#	Signal Name	Type	Description
FCFBGA	WLBGA	WLCSP			
–	B2, B4, B6	–	WRF_PA_GND	I	WLAN PA ground
C5	C4	9	WRF_PADRV_GND	I	WLAN PA driver ground
B2	–	7	WRF_GNDLNA_5G	I	WLAN 11a-band LNA ground
C6	C7	6	WRF_GNDLNA_2G	I	WLAN 11g-band LNA ground
C3	C1	2–3	WRF_ANA_GND	I	WLAN ADC/DAC ground
E2	F1	14	WRF_VCO_GND	I	WLAN VCO ground
F3	F4	4–5	WRF_AFE_GND	I	WLAN AFE ground
G2	H2	39	WRF_XTAL_GND	I	WLAN PLL ground
–	K2	–	WL_VSS_0	I	WLAN ground
–	L5	–	WL_VSS_1	I	
–	E5	–	WL_VSS_2	I	
–	C5	–	WRF_GND	I	WLAN RF block ground
C7	C8	58	BT_IFVSS	I	Bluetooth IF block ground
C8	C9	–	BT_VSS	I	Bluetooth ground
B8	A10	65	BT_FEVSS	I	Bluetooth ground
C9	–	63	BT_VCOVSS	I	Bluetooth VCO ground
B9	B10	–	BT_RFVSS	I	Bluetooth ground
D9	C10	60	BT_PLLVSS	I	Bluetooth PLL ground
–	–	62	BT_LNAVSS	I	Bluetooth LNA ground
–	F8	151–159	BT_VSSC	I	Bluetooth ground
–	–	209	PACKAGEOPTION_0	I	Connect to ground
–	–	210	PACKAGEOPTION_1	I	
–	–	211	PACKAGEOPTION_2	I	
C10	C11	53	FM_VSSAUDIO	I	FM audio ground
D11	E11	44–45	FM_RXVSS	I	FM receiver ground
E11	F11	49	FM_VSSVCO	I	FM VCO ground
D10	F10	55	FM_PLLVSS	I	FM PLL ground
E9	–	–	FM_VSS	I	FM ground
–	–	56	FM_IFVSS	I	FM IF block ground
G6, G7, G8, J4, J5, J6	–	–	VSSC	I	Ground
K2	M1	161	HSIC_AVSS	I	HSIC block ground
K10	L11	69–70	PMU_AVSS	I	PMU block analog ground
M11	M11	71–75	SR_PVSS	I	Switching regulator ground

Not Recommended for New Designs

Table 18: FCFBGA, WLBGA, and WLCSP Signal Descriptions (Cont.)

Ball#		Bump#		Signal Name	Type	Description
FCFBGA	WLBGA	WLCSP				
–	–	213–225		WL_VSS	I	WLAN ground
No Connect						
A1, A2	–	–		NC	N/A	No connect
K7	–	181		VDD_ISLAND	I	No connect

WLAN GPIO Signals and Strapping Options

The pins listed in Table 19 are sampled at power-on reset (POR) to determine the various operating modes. Sampling occurs a few milliseconds after an internal POR or deassertion of the external POR. After the POR, each pin assumes the GPIO or alternative function specified in the signal descriptions table. Each strapping option pin has an internal pull-up (PU) or pull-down (PD) resistor that determines the default mode. To change the mode, connect an external PU resistor to VDDIO or a PD resistor to GND, using a 10 kΩ resistor or less.



Note: Refer to the reference board schematics for more information.

Table 19: WLAN GPIO Functions and Strapping Options

Pin Name	FCFBGA Pin #	WLBGA Pin #	WLCSP Pin #	Default	Function	Description
SDIO_DATA_1	M5	M8	179	X	strap_host_ifc_1	The three pins strap_host_ifc_[3:1] together select the host interface mode:
SDIO_DATA_2	M8	M5	180	X	strap_host_ifc_2	
WL_GPIO_6	H4	D8	181	0	strap_host_ifc_3	

- 0XX: SDIO
- 10X: gSPI
- 110: normal HSIC
- 111: bootloader-less HSIC

Table 20: Strap Options

	strap_host_ifc_3 WL_GPIO_6	strap_host_ifc_2 SDIO_DATA_2	strap_host_ifc_1 SDIO_DATA_1
Default states at sampling instant	0	Float	Float
SDIO	0	x	x
gSPI	1	0	x
HSIC (normal)	1	1	0
Bootloader-less HSIC (debug only)	1	1	1

Muxed Bluetooth GPIO Signals

The Bluetooth GPIO pins (BT_GPIO_0 to BT_GPIO_7) are multiplexed pins and can be programmed to be used as GPIOs or for other Bluetooth interface signals such as I²S. The specific function for a given BT_GPIO_X pin is chosen by programming the Pad Function Control Register for that specific pin. Table 21 shows the possible options for each BT_GPIO_X pin. Note that each BT_GPIO_X pin's Pad Function Control Register Setting is independent (i.e. BT_GPIO_1 can be set to Pad Function 7 at the same time that BT_GPIO_3 is set to PAD Function 0). When the Pad Function Control Register is set to 0 the BT_GPIOs do not have specific functions assigned to them and behave as generic GPIOs. The A_GPIO_X pins described below are multiplexed behind the BCM4330 PCM and I²S interface pins.

Table 21: GPIO Multiplexing Matrix

Pin Name	Pad Function Control Register Setting							
	0	1	2	3	4	5	6	7
BT_UART_CTS_N	UART_CTS_N	–	–	–	–	–	–	A_GPIO[1]
BT_UART_RTS_N	UART_RTS_N	–	–	–	–	–	–	A_GPIO[0]
BT_UART_RXD	UART_RXD	–	–	–	–	–	–	GPIO[5]
BT_UART_TXD	UART_TXD	–	–	–	–	–	–	GPIO[4]
BT_PCM_IN	A_GPIO[3]	PCM_IN	PCM_IN	HCLK	–	–	–	I2S_SSDI/MSDI
BT_PCM_OUT	A_GPIO[2]	PCM_OUT	PCM_OUT	LINK_IND	–	I2S_MSDO	–	I2S_SSDO
BT_PCM_SYNC	A_GPIO[1]	PCM_SYNC	PCM_SYNC	HCLK	INT_LPO	I2S_MWS	–	I2S_SWS
BT_PCM_CLK	A_GPIO[0]	PCM_CLK	PCM_CLK	–	–	I2S_MSCK	–	I2S_SSCK
BT_I2S_DO	A_GPIO[5]	PCM_OUT	–	–	I2S_SSDO	I2S_MSDO	–	STATUS
BT_2S_DI	A_GPIO[6]	PCM_IN	–	HCLK	I2S_SSDI/ MSDI	–	–	TX_CON_FX
BT_I2S_WS	GPIO[7]	PCM_SYNC	–	LINK_IND	–	I2S_MWS	–	I2S_SWS
BT_I2S_CLK	GPIO[6]	PCM_CLK	–	–	INT_LPO	I2S_MSCK	–	I2S_SSCK
BT_GPIO_5	GPIO[5]	HCLK	–	I2S_MSCK	I2S_SSCK	–	–	CLK_REQ
BT_GPIO_4	GPIO[4]	LINK_IND	–	I2S_MSDO	I2S_SSDO	–	–	–
BT_GPIO_3	GPIO[3]	–	–	I2S_MWS	I2S_SWS	–	–	–
BT_GPIO_2	GPIO[2]	–	–	–	I2S_SSDI/ MSDI	–	–	–
BT_GPIO_1	GPIO[1]	–	–	–	–	–	–	–
BT_GPIO_0	GPIO[0]	–	–	–	clk_12p288	–	–	RF_ACTIVE
BT_CLK_REQ_IN	A_GPIO[4]	–	–	–	–	–	–	A_GPIO[4]
BT_CLK_REQ_OUT	WL/BT_CLK_REQ	–	–	–	–	–	–	A_GPIO[7]

The multiplexed GPIO signals are described in [Table 22](#).

Table 22: Multiplexed GPIO Signals

Pin Name	Type	Description
UART_CTS_N	I	Host UART clear to send
UART_RTS_N	O	Device UART request to send
UART_RXD	I	Device UART receive data
UART_TXD	O	Host UART transmit data
PCM_IN	I	PCM data input
PCM_OUT	O	PCM data output
PCM_SYNC	I/O	PCM sync signal, can be master (output) or slave (input)
PCM_CLK	I/O	PCM clock, can be master (output) or slave (input)
GPIO[7:0]	I/O	General purpose I/O
A_GPIO[7:0]	I/O	A group general purpose I/O
I2S_MSDO	O	I ² S master data output
I2S_MWS	O	I ² S master word select
I2S_MSCK	O	I ² S master clock
I2S_SSCK	I	I ² S slave clock
I2S_SSDO	O	I ² S slave data output
I2S_SWS	I	I ² S slave word select
I2S_SSDI/MSDI	I	I ² S slave/master data input
STATUS	O	Signals Bluetooth priority status
TX_CON_FX	I	WLAN-BT coexist. Transmission confirmation; permission for BT to transmit
RF_ACTIVE	O	WLAN-BT coexist. Asserted (logic high) during local BT RX and TX slots
LINK_IND	O	BT receiver/transmitter link indicator
WL/BT_CLK_REQ	O	WLAN clock request output

I/O States

The following notations are used in [Table 23](#):

- I: Input signal
- O: Output signal
- I/O: Input/Output signal
- PU = Pulled up
- PD = Pulled down
- NoPull = Neither pulled up nor pulled down

Table 23: I/O States

Name	I/O	Keeper ^a	Active Mode	Low Power State/Sleep (all power present)	Power Down ^b (BT_REG_ON and WL_REG_ON held low)	Out of Reset; Before SW Download (BT_RST_N high; xx_REG_ON high)
WL_REG_ON	I	N	I; PD (pull down can be disabled)	I; PD (pull down can be disabled)	I; PD (of 200K)	I; PD (of 200K)
BT_RST_N	I	Y	I; NoPull	I; NoPull	I; NoPull	I; NoPull
BT_REG_ON	I	N	I; PD (pull down can be disabled)	I; PD (pull down can be disabled)	I; PD (of 200K)	I; PD (of 200K)
BT_GPIO 0,1,2,3,4,5	I/O	Y	I/O; PU, PD, NoPull (programmable)	I/O; PU, PD, NoPull (programmable)	High-Z, NoPull	I, PD
BT_UART_CTS	I	Y	I; NoPull	I; NoPull	High-Z, NoPull	I; PU
BT_UART_RTS	O	Y	O; NoPull	O; NoPull	High-Z, NoPull	I; PU
BT_UART_RXD	I	Y	I; NoPull	I; NoPull	High-Z, NoPull	I; PU
BT_UART_TXD	O	Y	O; NoPull	O; NoPull	High-Z, NoPull	I; PU
SDIO Data	I/O	N	I/O; PU	I; PU	High-Z, NoPull	I; PU
SDIO CMD	I/O	N	I/O; PU	I; PU	High-Z, NoPull	I; PU
SDIO_CLK	I	N	I; NoPull	I; NoPull	High-Z, NoPull	I; NoPull
BT_PCM_CLK	I/O	Y	I; NoPull ^c	I; NoPull ^c	High-Z, NoPull	I, PD
BT_PCM_IN	I/O	Y	I; NoPull ^c	I; NoPull ^c	High-Z, NoPull	I, PD
BT_PCM_OUT	I/O	Y	I; NoPull ^c	I; NoPull ^c	High-Z, NoPull	I, PD

Table 23: I/O States (Cont.)

Name	I/O	Keeper^a	Active Mode	Low Power State/Sleep (all power present)	Power Down^b (BT_REG_ON and WL_REG_ON held low)	Out of Reset: Before SW Download (BT_RST_N high; xx_REG_ON high)
BT_PCM_SYNC	I/O	Y	I; NoPull ^c	I; NoPull ^c	High-Z, NoPull	I; PD
BT_I2S_WS	I/O	Y	I; NoPull ^d	I; NoPull ^d	High-Z, NoPull	I; PD
BT_I2S_CLK	I/O	Y	I; NoPull ^d	I; NoPull ^d	High-Z, NoPull	I; PD
WL GPIO_0	I/O	Y	I/O; PU, PD, NoPull (programmable [Default: PD])	I/O; PU, PD, NoPull (programmable [Default: PD])	High-Z, NoPull	I; PD
WL GPIO_1	I/O	Y	I/O; PU, PD, NoPull (programmable [Default: PU])	I/O; PU, PD, NoPull (programmable [Default: PU])	High-Z, NoPull	I; PU
WL GPIO_2	I/O	Y	I/O; PU, PD, NoPull (programmable [Default: PU])	I/O; PU, PD, NoPull (programmable [Default: PU])	High-Z, NoPull	I; PU
WL GPIO_3	I/O	Y	I/O; PU, PD, NoPull (programmable [Default: PU])	I/O; PU, PD, NoPull (programmable [Default: PU])	High-Z, NoPull	I; PU
WL GPIO_4	I/O	Y	I/O; PU, PD, NoPull (programmable [Default: NoPull])	I/O; PU, PD, NoPull (programmable [Default: NoPull])	High-Z, NoPull	I; NoPull
WL GPIO_5	I/O	Y	I/O; PU, PD, NoPull (programmable [Default: PU])	I/O; PU, PD, NoPull (programmable [Default: PU])	High-Z, NoPull	I; PU
WL GPIO_6	I/O	Y	I/O; PU, PD, NoPull (programmable [Default: PD])	I/O; PU, PD, NoPull (programmable [Default: PD])	High-Z, NoPull	I; PD

a. N = Pad has no keeper; Y = Pad has a keeper. The keeper is always active except in power down state.

b. If there is no keeper, it is an input, and there is no pull, then the pad should be driven to prevent leakage due to the floating pad.

c. In the power down state (xx_REG_ON = 0), High-Z; noPull: the pad is disabled because power is not supplied.

d. Depending on whether the PCM interface is enabled and the configuration of PCM is in master or slave mode, this can be either:
 1. The I²S interface is shared with GPIO2, 3, 4, and 5. Up to master or slave mode, it can be either output or input.

Section 15: DC Characteristics



Note: Values in this data sheet are design goals and are subject to change based on the results of device characterization.

Absolute Maximum Ratings



Caution! The absolute maximum ratings in [Table 24](#) indicate levels where permanent damage to the device can occur, even if these limits are exceeded for only a brief duration. Functional operation is not guaranteed under these conditions. Operation at absolute maximum conditions for extended periods can adversely affect long-term reliability of the device.

Table 24: Absolute Maximum Ratings

Rating	Symbol	Value	Unit
DC supply for VBATT	VBATT	-0.5 to 6.0	V
DC supply for WLAN power amplifier	VDDPA	-0.5 to 6.0	V
DC supply voltage for I/O	VDDIO	-0.5 to 2.98	V
Note: When using a 2.9V \pm 3% supply, a 2.98V to 3.09V range is allowed for a duration not to exceed 1.5 seconds for each power-up cycle. After that, the VDDIO supply for the chip must have a steady state operating condition within the range 2.9V \pm 3%.			
DC supply voltage for RF	VDDRF	-0.5 to 1.32	V
DC supply voltage for core	VDDC	-0.5 to 1.32	V
DC supply voltage for RF I/Os	VDDIO_RF	-0.5 to 3.8	V
DC input supply voltage for CLDO and LNLDO1	–	-0.5 to 2.1	V
WRF_VDD_VCOLDO_IN_1P8	–	-0.5 to 2.75	V
WRF_TCXO_VDD	–	-0.5 to 3.63	V
Maximum undershoot voltage for I/O	V _{undershoot}	-0.5	V
Maximum Junction Temperature	T _j	125	°C

Not Recommended for New Designs

Environmental Ratings

The environmental ratings are shown in [Table 25](#).

Table 25: Environmental Ratings

Characteristic	Value	Units	Conditions/Comments
Ambient Temperature (T_A)	-30 to +85	°C	Functional operation ^a
Storage Temperature	-40 to +125	°C	–
Relative Humidity	Less than 60	%	Storage
	Less than 85	%	Operation

- a. Functionality is guaranteed but specifications require derating at extreme temperatures; see the specification tables for details.

Electrostatic Discharge Specifications

Extreme caution must be exercised to prevent electrostatic discharge (ESD) damage. Proper use of wrist and heel grounding straps to discharge static electricity is required when handling these devices. Always store unused material in its antistatic packaging.

Table 26: ESD Specifications

Pin Type	Symbol	Condition	ESD Rating	Unit
ESD, Handling Reference: NQY00083, Section 3.4, Group D9, Table B	ESD_HAND_HBM	Human body model contact discharge per JEDEC EID/JESD22-A114	±1.5	kV
Machine Model (MM)	ESD_HAND_MM	JESD22-A115	±50	V
CDM	ESD_HAND_CDM	Charged device model contact discharge per JEDEC EIA/JESD22-C101	±200	V

Not Recommended for New Designs

Recommended Operating Conditions and DC Characteristics



Caution! Functional operation is not guaranteed outside of the limits shown in [Table 27](#) and operation outside these limits for extended periods can adversely affect long-term reliability of the device.

Table 27: Recommended Operating Conditions and DC Characteristics

Element	Symbol	Value			Unit
		Minimum	Typical	Maximum	
DC supply voltage for VBATT	VBATT	2.3 ^a	–	4.8 ^b	V
DC supply for WLAN power amplifier	VDDPA	2.3 ^a	3.3	4.8 ^b	V
DC supply voltage for core	VDD	1.14	1.2	1.26	V
DC supply voltage for RF blocks in chip	VDDRF	1.14	1.2	1.26	V
DC supply voltage for I/O	VDDIO	1.2	1.8	2.9 ±3%	V
Note: When using a 2.9V ±3% supply, a 2.98V to 3.09V range is allowed for a duration not to exceed 1.5 seconds for each power-up cycle. After that, the VDDIO supply for the chip must have a steady state operating condition within the range 2.9V ±3%.					
DC supply for HSIC interface	HSIC_ AVDD12	1.1	1.2	1.3	V
DC supply voltage for RF I/Os	VDDIO_RF ^c	3.14	3.3	3.46	V
Input High Voltage (WL_REG_ON, BT_REG_ON, EXT_SMS_REQ, EXT_PWM_REQ)	VIH	1.08	–	3.6	V
Input Low Voltage (WL_REG_ON, BT_REG_ON, EXT_SMS_REQ, EXT_PWM_REQ)	VIL	–	–	0.4	V
Input High Voltage (VDDIO = 1.2V)	VIH	0.7 × VDDIO	–	–	V
Input Low Voltage (VDDIO = 1.2V)	VIL	–	–	0.3 × VDDIO	V
Input High Voltage (VDDIO = 1.8V to 2.5V)	VIH	0.65 × VDDIO	–	–	V
Input Low Voltage (VDDIO = 1.8V to 2.5V)	VIL	–	–	0.35 × VDDIO	V
Input High Voltage (VDDIO = 2.9V ±3%)	VIH	0.65 × VDDIO	–	–	V
Input Low Voltage (VDDIO = 2.9V ±3%)	VIL	–	–	0.35 × VDDIO	V
Output High Voltage @ 100 μA (VDDIO = 1.2V)	VOH	VDDIO – 0.1	–	–	V
Output High Voltage @ 2 mA (VDDIO = 1.2V)	VOH	VDDIO – 0.2	–	–	V
Output Low Voltage @ 100 μA (VDDIO = 1.2V)	VOL	–	–	0.1	V
Output Low Voltage @ 2 mA (VDDIO = 1.2V)	VOL	–	–	0.2	V
Output High Voltage @ 100 μA (VDDIO = 1.8V to 2.9V)	VOH	VDDIO – 0.2	–	–	V

Not Recommended for New Designs

Table 27: Recommended Operating Conditions and DC Characteristics (Cont.)

<i>Element</i>	<i>Symbol</i>	<i>Value</i>			<i>Unit</i>
		<i>Minimum</i>	<i>Typical</i>	<i>Maximum</i>	
Output High Voltage @ 2 mA (VDDIO = 1.8V to 2.9V)	VOH	VDDIO – 0.45	–	–	V
Output Low Voltage @ 100 μ A (VDDIO = 1.8V to 2.9V)	VOL	–	–	0.2	V
Output Low Voltage @ 2 mA (VDDIO = 1.8V to 2.9V)	VOL	–	–	0.45	V
Input capacitance	C _{IN}	–	–	5	pF

- The BCM4330 is functional across this range of voltages. Optimal RF performance specified in this Data Sheet, however it is guaranteed only for $3.0V < V_{BAT} < 4.8V$.
- The max continuous voltage is 4.8V. Voltages up to 5.5V for up to 10 seconds, cumulative duration, over the lifetime of the device are allowed. Voltages as high as 5.0V for up to 250 seconds, cumulative duration, over the lifetime of the device are allowed.
- VDDIO_RF is generally supplied by the BCM4330 VOUT_3P3 output.

Not Recommended for New Designs

Section 16: Bluetooth RF Specifications



Note: Values in this data sheet are design goals and are subject to change based on the results of device characterization.

Unless otherwise stated, limit values apply for the conditions specified in [Table 25: “Environmental Ratings,” on page 118](#) and [Table 27: “Recommended Operating Conditions and DC Characteristics,” on page 119](#). Typical values apply for the following conditions:

- Vbatt = 3.6V
- Ambient temperature +25°C

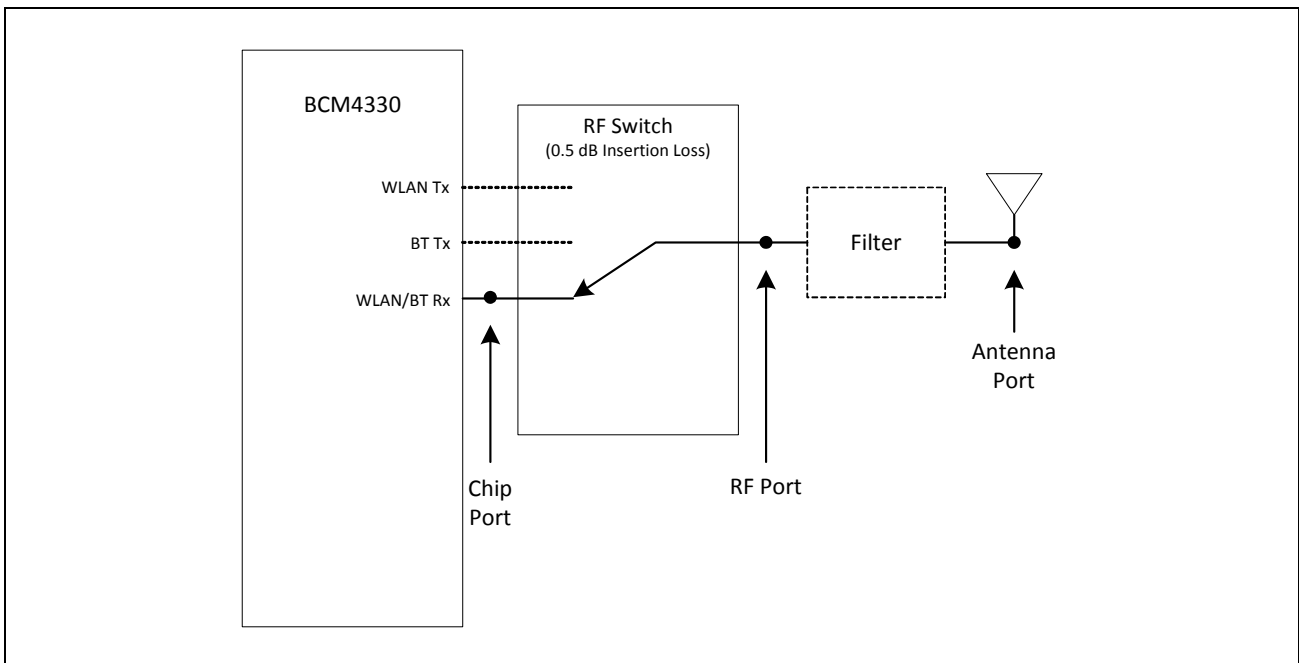

Figure 41: RF Port Location for Bluetooth Testing



Note: All Bluetooth specifications are measured at the RF port unless otherwise specified.

Not Recommended for New Designs

Table 28: Bluetooth Receiver RF Specifications

Parameter	Conditions	Minimum	Typical	Maximum	Unit
General					
Frequency range	–	2402	–	2480	MHz
RX sensitivity	GFSK, 0.1% BER, 1 Mbps	–	–93	–87.5	dBm
	$\pi/4$ -DQPSK, 0.01% BER, 2 Mbps	–	–95	–87.5	dBm
	8-DPSK, 0.01% BER, 3 Mbps	–	–89	–82.5	dBm
Input IP3	–	–16	–9	–	dBm
Maximum input at antenna	–	–	–	–20	dBm
Return loss of BT Rx and Tx pins 50 Ω port	–	10	–	–	dB
Interference Performance¹					
C/I cochannel	GFSK, 0.1% BER	–	–	11.0	dB
C/I 1 MHz adjacent channel	GFSK, 0.1% BER	–	–	0.0	dB
C/I 2 MHz adjacent channel	GFSK, 0.1% BER	–	–	–30.0	dB
C/I \geq 3 MHz adjacent channel	GFSK, 0.1% BER	–	–	–40.0	dB
C/I image channel	GFSK, 0.1% BER	–	–	–9.0	dB
C/I 1 MHz adjacent to image channel	GFSK, 0.1% BER	–	–	–20.0	dB
C/I cochannel	$\pi/4$ -DQPSK, 0.1% BER	–	–	13.0	dB
C/I 1 MHz adjacent channel	$\pi/4$ -DQPSK, 0.1% BER	–	–	0.0	dB
C/I 2 MHz adjacent channel	$\pi/4$ -DQPSK, 0.1% BER	–	–	–30.0	dB
C/I \geq 3 MHz adjacent channel	8-DPSK, 0.1% BER	–	–	–40.0	dB
C/I image channel	$\pi/4$ -DQPSK, 0.1% BER	–	–	–7.0	dB
C/I 1 MHz adjacent to image channel	$\pi/4$ -DQPSK, 0.1% BER	–	–	–20.0	dB
C/I cochannel	8-DPSK, 0.1% BER	–	–	21.0	dB
C/I 1 MHz adjacent channel	8-DPSK, 0.1% BER	–	–	5.0	dB
C/I 2 MHz adjacent channel	8-DPSK, 0.1% BER	–	–	–25.0	dB
C/I \geq 3 MHz adjacent channel	8-DPSK, 0.1% BER	–	–	–33.0	dB
C/I Image channel	8-DPSK, 0.1% BER	–	–	0.0	dB
C/I 1 MHz adjacent to image channel	8-DPSK, 0.1% BER	–	–	–13.0	dB

Not Recommended for New Designs

Table 28: Bluetooth Receiver RF Specifications (Cont.)

Parameter	Conditions	Minimum	Typical	Maximum	Unit
Out-of-Band Blocking Performance (CW)					
30–2000 MHz	0.1% BER	–	–10.0	–	dBm
2000–2399 MHz	0.1% BER	–	–27	–	dBm
2498–3000 MHz	0.1% BER	–	–27	–	dBm
3000 MHz–12.75 GHz	0.1% BER	–	–10.0	–	dBm
Out-of-Band Blocking Performance, Modulated Interferer²					
776–794 MHz	CDMA2000	–	–7	–	dBm
824–849 MHz	cdmaOne	–	–7	–	dBm
824–849 MHz	GSM850	–	–7	–	dBm
880–915 MHz	E-GSM	–	–8	–	dBm
1710–1785 MHz	GSM1800	–	–14	–	dBm
1850–1910 MHz	GSM1900	–	–15	–	dBm
1850–1910 MHz	cdmaOne	–	–14	–	dBm
1850–1910 MHz	WCDMA	–	–14	–	dBm
1920–1980 MHz	WCDMA	–	–15	–	dBm
Spurious Emissions					
30 MHz–1 GHz		–	–	–62	dBm
1–12.75 GHz		–	–	–47	dBm
851–894 MHz		–	–147	–	dBm/Hz
925–960 MHz		–	–147	–	dBm/Hz
1805–1880 MHz		–	–147	–	dBm/Hz
1930–1990 MHz		–	–147	–	dBm/Hz
2110–2170 MHz		–	–147	–	dBm/Hz

1. The maximum value represents the actual Bluetooth specification required for Bluetooth qualification as defined in the version 4.0 specification.

2. Bluetooth reference level for wanted signal at the Bluetooth RF port = –84.5 dBm.

Table 29: Bluetooth Transmitter RF Specifications

Parameter	Conditions	Minimum	Typical	Maximum	Unit
General					
Frequency range		2402	–	2480	MHz
Basic rate (GFSK) Tx power at Bluetooth RF port		–	12	–	dBm
QPSK Tx Power at Bluetooth RF Port		–	10	–	dBm
8PSK Tx Power at Bluetooth RF Port		–	10	–	dBm
Power control step		2	4	6	dB

Table 29: Bluetooth Transmitter RF Specifications (Cont.)

Parameter	Conditions	Minimum	Typical	Maximum	Unit
GFSK In-Band Spurious Emissions					
-20 dBc BW	–	–	–	1	MHz
EDR In-Band Spurious Emissions					
1.0 MHz < M – N < 1.5 MHz	M – N = the frequency range for which the spurious emission is measured relative to the transmit center frequency.	–	–33	–26.0	dBc
1.5 MHz < M – N < 2.5 MHz		–	–27	–20.0	dBm
M – N ≥ 2.5 MHz		–	–43	–40.0	dBm
Out-of-Band Spurious Emissions					
30 MHz to 1 GHz		–	–	–36.0 ^{a, b}	dBm
1 GHz to 12.75 GHz		–	–	–30.0 ^{b, c, d}	dBm
1.8 GHz to 1.9 GHz		–	–	–47.0	dBm
5.15 GHz to 5.3 GHz		–	–	–47.0	dBm
Rx LO Leakage					
2.4 GHz band		–	–	–60.0	dBm
GPS Band Spurious Emissions					
Spurious emissions		–	–150	–127	dBm/Hz
Out-of-Band Noise Floor^e					
65–108 MHz	FM Rx	–	–146	–	dBm/Hz
776–794 MHz	CDMA2000	–	–146	–	dBm/Hz
869–960 MHz	cdmaOne, GSM850	–	–146	–	dBm/Hz
925–960 MHz	E-GSM	–	–146	–	dBm/Hz
1570–1580 MHz	GPS	–	–143	–	dBm/Hz
1805–1880 MHz	GSM1800	–	–140	–	dBm/Hz
1930–1990 MHz	GSM1900, cdmaOne, WCDMA	–	–138	–	dBm/Hz
2110–2170 MHz	WCDMA	–	–135	–	dBm/Hz

- The maximum value represents the value required for Bluetooth qualification as defined in the v4.0 specification.
- The spurious emissions during Idle mode are the same as specified in [Table 29 on page 123](#).
- Specified at the Bluetooth antenna port.
- Meets this specification using a front-end band-pass filter.
- Transmitted power in cellular and FM bands at the Bluetooth antenna port. See [Figure 41 on page 121](#) for location of the port.

Table 30: Local Oscillator Performance

Parameter	Minimum	Typical	Maximum	Unit
LO Performance				
Lock time	–	72	–	μs
Initial carrier frequency tolerance	–	±25	±75	kHz
Frequency Drift				
DH1 packet	–	25	±25	kHz
DH3 packet	–	40	±40	kHz
DH5 packet	–	40	±40	kHz
Drift rate	–	6	20	kHz/50 μs
Frequency Deviation				
00001111 sequence in payload ^a	140	147	175	kHz
10101010 sequence in payload ^b	115	138	–	kHz
Channel spacing	–	1	–	MHz

a. This pattern represents an average deviation in payload.

b. Pattern represents the maximum deviation in payload for 99.9% of all frequency deviations.

Not Recommended for New Designs

Section 17: FM Transmitter Specifications



Note: Values in this data sheet are design goals and are subject to change based on the results of device characterization.

Unless otherwise stated, limit values apply for the conditions specified in [Table 27: “Recommended Operating Conditions and DC Characteristics,”](#) on page 119. Typical values apply for the following conditions:

- Vbatt = 3.6V
- Ambient temperature +25°C

Table 31: FM Transmitter Specifications

Parameter	Conditions	Min	Typ	Max	Units	
Synthesizer RF Parameters						
Operating frequency	Frequencies inclusive	76	–	108	MHz	
Frequency step	Channel resolution		50		kHz	
Settling time	Single frequency switch in any direction to a frequency within the bands 88–108 MHz or 76–95 MHz. Time measured to within 5 kHz of the final frequency.	–	–	40	ms	
FM Rx/Tx antenna switching time	–	–	5	–	ms/ channel	
Frequency accuracy	Over temperature and voltage using available reference clocks	–10	–	10	kHz	
Transmitter Output						
Maximum transmit output level	Driving from a current source output into a resonated loop antenna for which L = 120 nH nominal, with a Q ≥ 30, all Tx frequencies ON, L= R = 0 (that is, no modulation), 0 dB internal attenuation/gain, and a 2.5V supply.					
		87.5–108 MHz	120	123	–	dBuV
		76–87.5 MHz	117	–	–	dBuV
Tuning capacitance range	76 to 108 MHz Based on tuning inductance of 120 to 150 nH	–	–	–	pF	
Transmitter output accuracy ^a	Over entire output range	–2	–	2	dB	
Gain step accuracy	25 levels in normal 1 dB steps, one of those being 0 dB	–0.5	1	1.5	dB	
Pilot deviation	Relative to maximum peak deviation	8	–	10	%	

Not Recommended for New Designs

Table 31: FM Transmitter Specifications (Cont.)

Parameter	Conditions	Min	Typ	Max	Units
Transmitted spectrum for maximum deviation	Total peak deviation set to 75 kHz. Audio tone of 1 kHz, pilot = 6.75 kHz.	–	–	–	–
	0 kHz offset from carrier	–	–	0	dBc
	± 50 kHz offset	–	–	0	dBc
	± 75 kHz offset	–	–	0	dBc
	± 120 kHz offset	–	–	–12.2	dBc
Occupied BW	± 100 kHz offset from nominal channel freq	–	–	–20	dBc
Transmitter noise floor	From 850 MHz to 2.4 GHz	–	–	–	dBm/Hz
Composite transmitted deviation	L = R set to 75 mV rms, stereo enabled	–	–	± 75	kHz peak
Transmitter spurious	Load 120 nH: Q ≥ 30	–	–	–	–
	746–764 MHz	–	–	19	dBuV
	869–894 MHz, 925–960 MHz, 1805–1880 MHz, 1930–1990 MHz	–	–	12	dBuV
	2110–2170 MHz	–	–	20	dBuV
	1570–1580 MHz	–	–	6	dBuV
Transmitted deviation flatness	Change in audio level for 75 kHz deviation over 76–108 MHz	–	–	±1	dB
Channel balance	1 kHz tone for 22.5 kHz audio deviation L = R, pilot 6.75 kHz	–1	–	1	dB
Stereo separation	1 kHz tone for 22.5 kHz audio deviation L ≠ R, pilot 6.75 kHz	27	40	–	dB
	Lower 3 dB point ^b (measured with receiver set to correct de-emphasis)	–	–	50	Hz
	Upper 3 dB point ^a	15	–	–	kHz
Pre-emphasis time constant	High	–	75	–	μs
	Low	–	50	–	μs
	Tolerance	–	–	± 5	%
Distortion	75 kHz total deviation including 6.75 kHz pilot, 1 kHz modulation rate	–	0.1	1	%
Transmitted S/N depends on the 32.768 kHz sleep clock phase noise performance	Deviation set to 22.5 kHz with 6.75 kHz pilot deviation. Measured with 50 μS de-emphasis and A-weighted filter. Forced Mono	–	60	–	dB
	As above in Stereo	–	56	–	dB
Audio spurious products	Δf = 22.5 kHz, fmod = 1 kHz, de-emphasis = 50 μs, L = R, BAF = 300 Hz to 15 kHz, fTX = 76 to 108 MHz	–	–	–60	dBc ^b

a. Relative to mean power in the band.

b. With respect to a 1 kHz tone.

Not Recommended for New Designs

Section 18: FM Receiver Specifications



Note: Values in this data sheet are design goals and are subject to change based on the results of device characterization.

Unless otherwise stated, limit values apply for the conditions specified in [Table 25: “Environmental Ratings,”](#) on page 118 and [Table 27: “Recommended Operating Conditions and DC Characteristics,”](#) on page 119. Typical values apply for the following conditions:

- V_{batt} = 3.6V
- Ambient temperature +25°C

Table 32: FM Receiver Specifications

Parameter	Conditions	Minimum	Typical	Maximum	Units
RF Parameters					
Operating frequency	Frequencies inclusive	65 ^a	–	108	MHz
Sensitivity ^b , V _{RF}	FM only, f _{mod} = 1 kHz, Δf = 22.5 kHz, (S+N)/N = 26 dB, BAF = 300 Hz to 15 kHz, A-weighted, Deemphasis = 50 μs, f _{IN} = 76 to 108 MHz	–	1.09	3.44	μV EMF
		–	–5	5	dBuV
	RDS. For an RDS deviation of 1.2 kHz. 95% of blocks decoded with no errors, over a sample of 5000 blocks.	–	8.64	15.36	μV EMF
		–	13	18	dBuV
	RDS. For an RDS deviation of 2 kHz. 95% of blocks decoded with no errors, over a sample of 5000 blocks.	–	5.45	10.87	μV EMF
		–	9	15	dBuV
RDS selectivity	Wanted RF level = RDS sensitivity + 3 dB, 2 kHz deviation. Interferer 40-kHz deviation 1 kHz tone.				
	Interferer level for 5% BLER				
	±200 kHz	–	50	–	dB
	±400 kHz	–	60	–	dB
	Image frequency ^c	–	–	–	dB
Receiver adjacent channel selectivity	At ±200 kHz. f _{IN} = 65 to 108 MHz. Measured for 26 dB SNR at the audio output.	–	50	–	dB
	At ±300 kHz and above	–	60	–	dB

Not Recommended for New Designs

Table 32: FM Receiver Specifications (Cont.)

Parameter	Conditions	Minimum	Typical	Maximum	Units
Image response (assuming image frequency $\geq \pm 300$ kHz), mono	At $f_{\text{desired}} \pm 2\text{fIF}$, depending on LO injection relative to f_{desired} . Measured for 40 dB (S + N)/N at the audio output. fIF = ± 325 kHz and ± 375 kHz.	25	–	–	dB
AM suppression, mono	Vin = 14.1 μV EMF, fmod = 1 kHz, Δf = 22.5 kHz, m = 0.3, BAF = 300 Hz to 15 kHz, L = R, Deemphasis = 75 μs	40	–	–	dB
Intermediate S/N	Vin = 10 μV EMF, fmod = 1 kHz, Δf = 22.5 kHz, BAF = 300 Hz to 15 kHz A-weighted, mono, Deemphasis = 50 μs	45	–	–	dB
Intermodulation performance	Desired signal 1 kHz modulation, deviation 22.5kHz Interferer 1 kHz modulation, deviation 22.5 kHz Blocker level increased until desired at 26 dB (S + N)/N. Desired signal level				
	4.5 μV EMF	–	50	–	dBc
	45 μV EMF	–	50	–	dBc
	450 μV EMF	–	50	–	dBc
RF Input					
RF input impedance	High Z	1.5	–	–	k Ω
RF input level	Maximum input level	–	–	354	mV EMF
RF conducted emissions	Local oscillator breakthrough measured on the reference port	–	–	–55	dBm
	925–960 MHz, 1805–1880 MHz, and 1930–1990 MHz	–	–	–90	dBm
RF blocking levels at the FM antenna input 26 dB (S+N)/N (Assumes presence of an external matching circuit)	824–915 MHz, GSM 200 kHz BW, CDMA 1.2 MHz BW	–	–	0	dBm
	1710–1980 MHz, GSM 200 kHz BW, CDMA 1.2 MHz BW, WCDMA 4 MHz BW	–	–	–5	dBm

Not Recommended for New Designs

Table 32: FM Receiver Specifications (Cont.)

Parameter	Conditions	Minimum	Typical	Maximum	Units
PLL					
Frequency step	Channel offset	10	–	–	kHz
Settling time	Single frequency switch in any direction to a frequency within the bands 88–108 MHz or 76–90 MHz. Time measured to within 5 kHz of the final frequency.	–	–	5	μs
Sweep time	Total time for an automatic search to sweep from 88–108 MHz or 76–90 MHz (and reverse direction) assuming no channels found.	–	–	8	sec
Soft Mute					
Soft mute start level	Mute attenuation = 3 dB	3	–	10	μV
Soft mute attenuation	V _{in} = 1 μV, Δf = 22.5 kHz, L = R fmod = 1 kHz, BAF = 300 Hz to 15 kHz, Deemphasis = 75 μs	–	30	–	dB
General Audio					
Audio output level	V _{in} = 1 mV, Δf = 22.5 kHz, fmod = 1 kHz, L = R, Deemphasis = 75 μs, Δf Pilot = 6.5 kHz, Rload >20 kΩ	60	75	90	mV rms
Maximum audio output level	V _{in} = 1 mV, Δf = 100 kHz, fmod = 1 kHz, L = R, Deemphasis = 75 μs, Δf Pilot = 6.5 kHz, Rload >20 kΩ	–	–	333	mV rms
Audio output level difference	V _{in} = 1 mV, Δf = 22.5 kHz, fmod = 1 kHz, L = R, Deemphasis = 75 μs, Rload >20 kΩ	–1	–	–1	dB
Maximum signal plus noise-to-noise ratio (S+N)/N, mono	V _{in} = 1 mV, Δf = 22.5 kHz, fmod = 1 kHz, L = R,	–	60	–	dB
Maximum signal plus noise-to-noise ratio (S+N)/N, stereo	Deemphasis = 50 μs, BAF = 300 Hz to 15 kHz (A-Weighted)	–	56	–	dB

Not Recommended for New Designs

Table 32: FM Receiver Specifications (Cont.)

Parameter	Conditions	Minimum	Typical	Maximum	Units
Total harmonic distortion, mono	Vin = 1 mV, Δf = 75 kHz, L = R, fmod = 400 Hz, Deemphasis = 50 μs	–	0.2	0.8	%
	Vin = 1 mV, Δf = 75 kHz, L = R, fmod = 1 kHz, Deemphasis = 50 μs	–	0.2	0.8	%
	Vin = 1 mV, Δf = 75 kHz, L = R, fmod = 3 kHz, Deemphasis = 50 μs	–	0.2	0.8	%
	Vin = 1 mV, Δf = 100 kHz, L = R, fmod = 1 kHz, Deemphasis = 50 μs	–	0.2	0.8	%
Total harmonic distortion, stereo	Vin = 1 mV, Δf = 75 kHz, L = R, fmod = 3 kHz, Deemphasis = 50 μs	–	0.4	1.5	%
Audio spurious products	Vin = 1 mV, Δf = 22.5 kHz, fmod = 1 kHz, Deemphasis = 50 μs, L = R, Range from 300 Hz to 15 kHz, with respect to 1 kHz tone	–	–	–60	dBc
Audio bandwidth, upper (–3 dB point)	Vin = 1 mV, Δf = 22.5 kHz, for both 50 and 75 μs Deemphasis, pre-emphasis applied.	15	–	–	kHz
Audio bandwidth, lower (–3 dB point)	Lower audio bandwidth (–3 dB point) measured at application circuit with AC coupling capacitor.	–	–	20	Hz
Deviation of the audio response from an ideal deemphasis curve	100 Hz to 13 kHz, Vin = 1 mV, Δf = 22.5 kHz, for both 50 and 75 μs Deemphasis, pre-emphasis applied	–	–	±0.5	dB
Deemphasis time constant tolerance	With respect to 50 and 75 μs	–	–	±5	%
RSSI range	±3 dB accuracy with 1 dB resolution	–110	–	–30	dBm

Pause Detection

Not Recommended for New Designs

Table 32: FM Receiver Specifications (Cont.)

Parameter	Conditions	Minimum	Typical	Maximum	Units
Audio level at which a pause is detected	Relative to 1-kHz tone, 22.5 kHz deviation, 50 μ s deemphasis	-	-	-	-
	4 values in 3 dB steps	-21	-	-12	dB
Audio pause duration	4 values	20	-	40	ms
Stereo Decoder					
Stereo channel separation	Forced Stereo mode Input signal level 2 mV EMF $\Delta f = 67.5$ kHz Fmod = 1 kHz R = 0, L = 1 including 9% pilot	30	-	-	dB
Pilot suppression	Measured at audio outputs. $\Delta f = 75$ kHz, fmod = 1 kHz, Deemphasis = 75 μ s	46	-	-	dB

- a. Please contact Broadcom regarding applications that will operate between 65 and 76 MHz.
- b. RDS sensitivity numbers are for 87.5–108 MHz only.
- c. Best Tune algorithm is used during normal operation to avoid image interference.

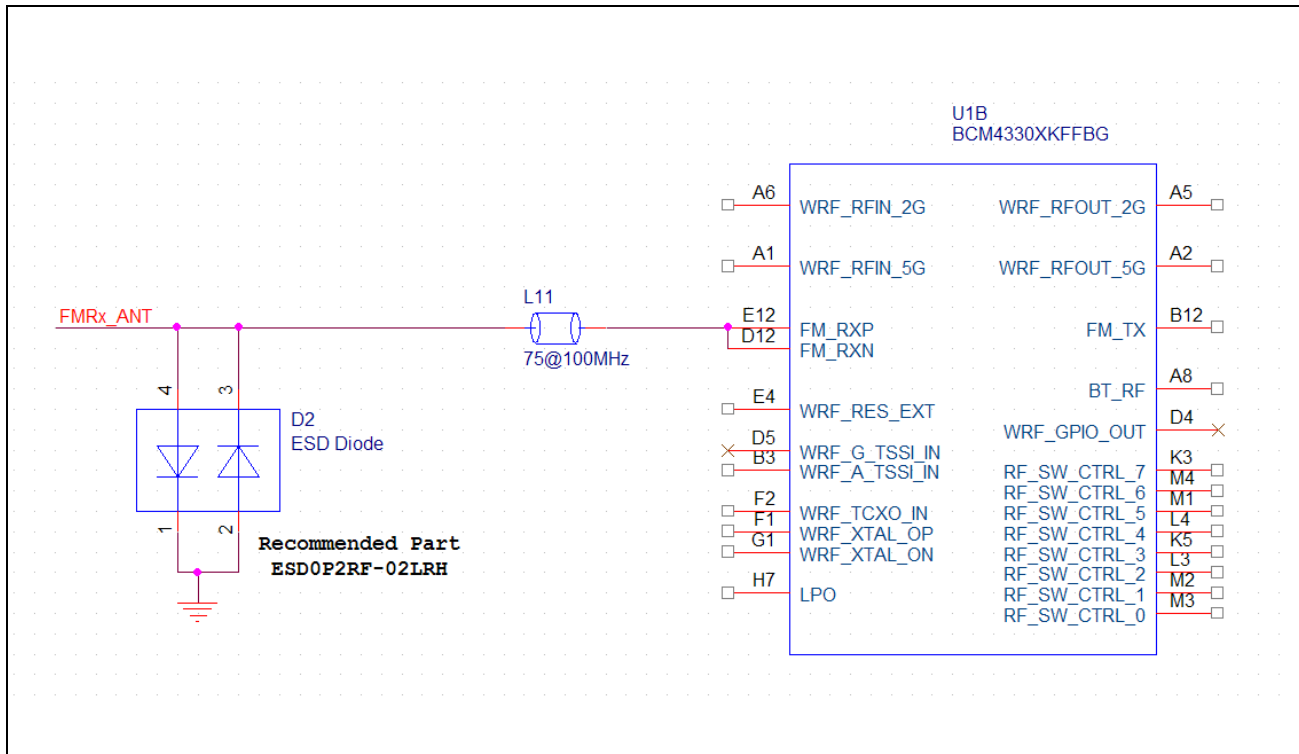



Figure 42: FM Receiver Circuit

Not Recommended for New Designs

Section 19: WLAN RF Specifications

Introduction

The BCM4330 includes an integrated dual-band direct conversion radio that supports either the 2.4 GHz band or the 5 GHz band. The BCM4330 does not provide simultaneous 2.4 GHz and 5 GHz operation. This section describes the RF characteristics of the 2.4 GHz and 5 GHz portions of the radio.

 **Note:** Values in this data sheet are design goals and are subject to change based on the results of device characterization.

Unless otherwise stated, limit values apply for the conditions specified in [Table 25: “Environmental Ratings,” on page 118](#) and [Table 27: “Recommended Operating Conditions and DC Characteristics,” on page 119](#). Typical values apply for the following conditions:

- Vbatt = 3.6V
- Ambient temperature +25°C

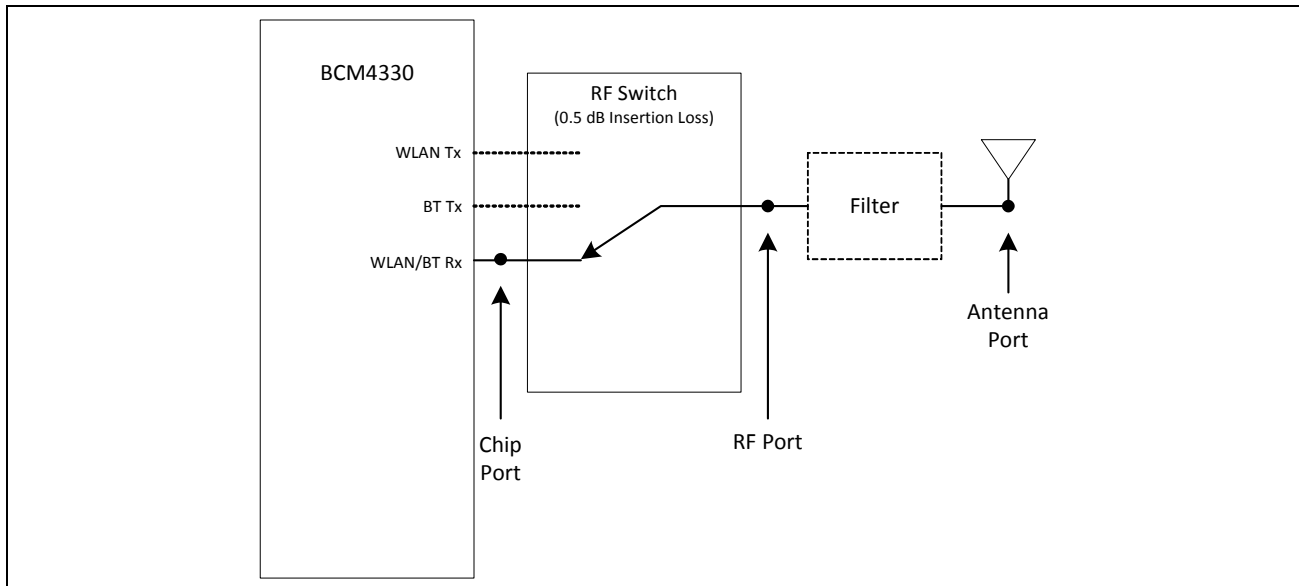



Figure 43: Port Locations

 **Note:** All WLAN specifications are measured at the chip port, unless otherwise specified.

Not Recommended for New Designs

2.4 GHz Band General RF Specifications

Table 33: 2.4 GHz Band General RF Specifications

<i>Item</i>	<i>Condition</i>	<i>Minimum</i>	<i>Typical</i>	<i>Maximum</i>	<i>Unit</i>
Tx/Rx switch time	Including TX ramp down	–	–	5	μs
Rx/Tx switch time	Including TX ramp up	–	–	2	μs
Power-up and power-down ramp time	DSSS/CCK modulations	–	–	< 2	μs

WLAN 2.4 GHz Receiver Performance Specifications



Note: The specifications in [Table 34](#) are measured at the chip port, unless otherwise specified.

Table 34: WLAN 2.4 GHz Receiver Performance Specifications

<i>Parameter</i>	<i>Condition/Notes</i>	<i>Minimum</i>	<i>Typical</i>	<i>Maximum</i>	<i>Unit</i>
Frequency range	–	2400	–	2500	MHz
RX sensitivity (8% PER for 1024 octet PSDU) ^a	1 Mbps DSSS	–	–97	–	dBm
	2 Mbps DSSS	–	–94	–	dBm
	5.5 Mbps DSSS	–	–92	–	dBm
	11 Mbps DSSS	–	–90	–	dBm
RX sensitivity (10% PER for 1000 octet PSDU) ^a	6 Mbps OFDM	–	–92	–	dBm
	9 Mbps OFDM	–	–90.5	–	dBm
	12 Mbps OFDM	–	–90	–	dBm
	18 Mbps OFDM	–	–88	–	dBm
	24 Mbps OFDM	–	–87	–	dBm
	36 Mbps OFDM	–	–83	–	dBm
	48 Mbps OFDM	–	–78	–	dBm
54 Mbps OFDM	–	–77	–	dBm	

Not Recommended for New Designs

Table 34: WLAN 2.4 GHz Receiver Performance Specifications (Cont.)

Parameter	Condition/Notes	Minimum	Typical	Maximum	Unit	
RX sensitivity (10% PER for 4096 octet PSDU) ^{a,b} . Defined for default parameters: GF, 800 ns GI, and non-STBC.	20 MHz channel spacing for all MCS rates					
	MCS 7	–	–74	–	dBm	
	MCS 6	–	–74.5	–	dBm	
	MCS 5	–	–76.5	–	dBm	
	MCS 4	–	–80.5	–	dBm	
	MCS 3	–	–84	–	dBm	
	MCS 2	–	–86.5	–	dBm	
	MCS 1	–	–88.5	–	dBm	
Blocking level for 1dB Rx sensitivity degradation (without external filtering) ^c	776–794 MHz	CDMA2000	–	–24	–	dBm
	824–849 MHz ^d	cdmaOne	–	–25	–	dBm
	824–849 MHz	GSM850	–	–15	–	dBm
	880–915 MHz	E-GSM	–	–16	–	dBm
	1710–1785 MHz	GSM1800	–	–18	–	dBm
	1850–1910 MHz	GSM1800	–	–19	–	dBm
	1850–1910 MHz	cdmaOne	–	–26	–	dBm
	1850–1910 MHz	WCDMA	–	–26	–	dBm
In-band static CW jammer immunity (fc – 8 MHz < fcw + 8 MHz)	Rx PER < 1%, 54 Mbps OFDM, 1000 octet PSDU for: (RxSens + 23 dB < Rxlevel < max input level)	–80	–	–	dBm	
	Input In-Band IP3 ^a	Maximum LNA gain	–	–15.5	–	dBm
	Minimum LNA gain	–	–1.5	–	dBm	
Maximum Receive Level @ 2.4 GHz	@ 1, 2 Mbps (8% PER, 1024 octets)	–3.5	–	–	dBm	
	@ 5.5, 11 Mbps (8% PER, 1024 octets)	–9.5	–	–	dBm	
	@ 6–54 Mbps (10% PER, 1024 octets)	–9.5	–	–	dBm	
	@ MCS0–7 rates (10% PER, 4095 octets)	–9.5	–	–	dBm	
LPF 3 dB Bandwidth	–	9	–	10	MHz	
Adjacent channel rejection-DSSS (Difference between interfering and desired signal at 8% PER for 1024 octet PSDU with desired signal level as specified in Condition/Notes)	Desired and interfering signal 30 MHz apart					
	1 Mbps DSSS	–74 dBm	35	–	–	dB
	2 Mbps DSSS	–74 dBm	35	–	–	dB
	Desired and interfering signal 25 MHz apart					
	5.5 Mbps DSSS	–70 dBm	35	–	–	dB
	11 Mbps DSSS	–70 dBm	35	–	–	dB

Not Recommended for New Designs

Table 34: WLAN 2.4 GHz Receiver Performance Specifications (Cont.)

Parameter	Condition/Notes	Minimum	Typical	Maximum	Unit	
Adjacent channel rejection-OFDM (Difference between interfering and desired signal (25 MHz apart) at 10% PER for 1024 octet PSDU with desired signal level as specified in Condition/Notes)	6 Mbps OFDM	-79 dBm	16	-	-	dB
	9 Mbps OFDM	-78 dBm	15	-	-	dB
	12 Mbps OFDM	-76 dBm	13	-	-	dB
	18 Mbps OFDM	-74 dBm	11	-	-	dB
	24 Mbps OFDM	-71 dBm	8	-	-	dB
	36 Mbps OFDM	-67 dBm	4	-	-	dB
	48 Mbps OFDM	-63 dBm	0	-	-	dB
	54 Mbps OFDM	-62 dBm	-1	-	-	dB
Adjacent channel rejection MCS0-7 (Difference between interfering and desired signal (25 MHz apart) at 10% PER for 4096 octet PSDU with desired signal level as specified in Condition/Notes)	MCS7	-61 dBm	-2	-	-	dB
	MCS6	-62 dBm	-1	-	-	dB
	MCS5	-63 dBm	0	-	-	dB
	MCS4	-67 dBm	4	-	-	dB
	MCS3	-71 dBm	8	-	-	dB
	MCS2	-74 dBm	11	-	-	dB
	MCS1	-76 dBm	13	-	-	dB
	MCS0	-79 dBm	16	-	-	dB
Maximum receiver gain	-	-	-	105	-	dB
Gain control step	-	-	-	3	-	dB
RSSI accuracy ^e	Range -98 dBm to -30 dBm	-5	-	5	-	dB
	Range above -30 dBm	-8	-	8	-	dB
Return loss	Zo = 50Ω, across the dynamic range	10	11.5	13	-	dB

- Derate by 1.5 dB for -30 °C to -10°C and 55°C to 85°C.
- Sensitivity degradations for alternate settings in MCS modes. MM: 0.5 dB drop, SGI: 2 dB drop, and STBC: 0.75 dB drop.
- The cellular standard listed for each band indicates the type of modulation used to generate the interfering signal in that band for the purpose of this test. It is not intended to indicate any specific usage of each band in any specific country.
- The blocking levels are valid for channels 1 to 11. (For higher channels, the performance may be lower due to third harmonic signals (3 × 824 MHz) falling within band.)
- The minimum and maximum values shown have a 95% confidence level.

Not Recommended for New Designs

WLAN 2.4 GHz Transmitter Performance Specifications



Note: The specifications in [Table 35](#) are measured at the chip port output, unless otherwise specified.

Table 35: WLAN 2.4 GHz Transmitter Performance Specifications

Parameter	Condition/Notes		Minimum	Typical	Maximum	Unit
Frequency range	–		2400	–	2500	MHz
Transmitted power in cellular and FM bands (at 21 dBm, >90% duty cycle, 1 Mbps CCK) ^a	76–108 MHz	FM Rx	–	–149	–	dBm/Hz
	776–794 MHz	–	–	–127	–	dBm/Hz
	869–960 MHz	cdmaOne, GSM850	–	–163	–	dBm/Hz
	925–960 MHz	E-GSM	–	–163	–	dBm/Hz
	1570–1580 MHz	GPS	–	–150	–	dBm/Hz
	1805–1880 MHz	GSM1800	–	–141	–	dBm/Hz
	1930–1990 MHz	GSM1900, cdmaOne, WCDMA	–	–138	–	dBm/Hz
	2110–2170 MHz	WCDMA	–	–129	–	dBm/Hz
	2.5 to 3.6 GHz	WIMAX CH1	–	–115 to –142	–	dBm/Hz
2.5 to 3.6 GHz	WIMAX CH13	–	–113 to –145	–	dBm/Hz	
Harmonic level (at 18 dBm with 100% duty cycle)	4.8–5.0 GHz	2nd harmonic	–	–	–10	dBm/ 1 MHz
	7.2–7.5 GHz	3rd harmonic	–	–	–28	dBm/ 1 MHz
<i>EVM Does Not Exceed</i>						
Tx power for highest power level setting at 25°C, VBATT = 3.6V and spectral mask and EVM compliance ^{b, c}	802.11b (DSSS/CCK)	–9 dB	–	20.5	–	dBm
	OFDM, BPSK	–8 dB	–	20	–	dBm
	OFDM, QPSK	–13 dB	–	20	–	dBm
	OFDM, 16-QAM	–19 dB	–	17.5	–	dBm
	OFDM, 64-QAM (R = 3/4)	–25 dB	–	17.5	–	dBm
	OFDM, 64-QAM (R = 5/6)	–28 dB	–	15.5	–	dBm
Tx power control dynamic range	–		10	–	–	dB

Not Recommended for New Designs

Table 35: WLAN 2.4 GHz Transmitter Performance Specifications (Cont.)

Parameter	Condition/Notes	Minimum	Typical	Maximum	Unit	
Closed-loop Tx power variation	Across full temperature and voltage range. Power accuracy of ± 1.5 dB for 10–20 dBm and ± 3 dB for 5–10 dBm.	–	–	± 1.5	dB	
PSAT algorithm Tx power variation (Additional back-off due to temperature and voltage by the PSAT algorithm. This is in addition to the closed-loop Tx power variation.)	VBATT > 3.6V, –30 to 55°C. All rates.	–	–	0	dB	
	VBATT > 3.6V, 85°C. All rates.	–	–	1.5	dB	
	VBATT = 2.7V, –30 to 85°C. 18, 12, 9, and 6 Mbps, and all CCK rates.	–	–	1	dB	
	VBATT = 2.7V, –30 to 85°C. 54, 48, 36, and 24 Mbps, and all 802.11n rates.	–	–	1.5	dB	
	VBATT = 2.3V, –30 to 85°C. All rates.	–	–	6	dB	
Carrier suppression	–	15	–	–	dBc	
Gain control step	–	–	0.25	–	dB	
Return loss	Z _o = 50Ω	4	6	–	dB	
Load pull variation for output power, EVM, and Adjacent Channel Power Ratio (ACPR)	2:1	EVM degradation	–	3.5	–	dB
		Output power variation	–	± 1.5	–	dB
		ACPR-compliant power level	–	15	–	dBm

- The cellular standards listed indicate only typical usages of that band in some countries. Other standards may also be used within those bands.
- Derate by 1.5 dB for –30 °C to –10°C and 55°C to 85°C.
- Tx power for Ch 1 and Ch 11 is specified by non-volatile memory parameters.

WLAN 5 GHz Receiver Performance Specifications



Note: The specifications in [Table 36](#) are measured at the chip port input, unless otherwise specified.

Table 36: WLAN 5 GHz Receiver Performance Specifications

<i>Parameter</i>	<i>Condition/Notes</i>	<i>Minimum</i>	<i>Typical</i>	<i>Maximum</i>	<i>Unit</i>	
Frequency range	–	4900	–	5845	MHz	
RX sensitivity	6 Mbps OFDM	–	–83	–	dBm	
(10% PER for 1000 octet PSDU) ^a	9 Mbps OFDM	–	–82	–	dBm	
	12 Mbps OFDM	–	–81	–	dBm	
	18 Mbps OFDM	–	–79	–	dBm	
	24 Mbps OFDM	–	–77	–	dBm	
	36 Mbps OFDM	–	–73	–	dBm	
	48 Mbps OFDM	–	–69	–	dBm	
	54 Mbps OFDM	–	–68	–	dBm	
RX sensitivity (10% PER for 4096 octet PSDU) ^a	HT mode MCS 7 (64 QAM, R = 5/6, 20 MHz channel spacing)	–	–64.5	–	dBm	
Blocking level for 1 dB Rx sensitivity degradation (without external filtering) ^b	776–794 MHz	CDMA2000	–	–19.5	–	dBm
	824–849 MHz	cdmaOne	–	–21.5	–	dBm
	824–849 MHz	GSM850	–	–10	–	dBm
	880–915 MHz	E-GSM	–	–9.5	–	dBm
	1710–1785 MHz	GSM1800	–	–13.5	–	dBm
	1850–1910 MHz	GSM1800	–	–13.5	–	dBm
	1850–1910 MHz	cdmaOne	–	–20.5	–	dBm
	1850–1910 MHz	WCDMA	–	–20.5	–	dBm
	1920–1980 MHz	WCDMA	–	–20.5	–	dBm
Input In-Band IP3 ^a	2500–2690 MHz	WiMAX	–	–21	–	dBm
	Maximum LNA gain	–	–15.5	–	dBm	
Maximum receive level @ 5.24 GHz	Minimum LNA gain	–	–1.5	–	dBm	
	@ 6, 9, 12 Mbps	–9.5	–	–	dBm	
LPF 3 dB bandwidth	@ 18, 24, 36, 48, 54 Mbps	–14.5	–	–	dBm	
	–	9	–	10	MHz	

Not Recommended for New Designs

Table 36: WLAN 5 GHz Receiver Performance Specifications (Cont.)

Parameter	Condition/Notes	Minimum	Typical	Maximum	Unit	
Adjacent channel rejection (Difference between interfering and desired signal (20 MHz apart) at 10% PER for 1000 octet PSDU with desired signal level as specified in Condition/Notes)	6 Mbps OFDM	-79 dBm	16	-	-	dB
	9 Mbps OFDM	-78 dBm	15	-	-	dB
	12 Mbps OFDM	-76 dBm	13	-	-	dB
	18 Mbps OFDM	-74 dBm	11	-	-	dB
	24 Mbps OFDM	-71 dBm	8	-	-	dB
	36 Mbps OFDM	-67 dBm	4	-	-	dB
	48 Mbps OFDM	-63 dBm	0	-	-	dB
	54 Mbps OFDM	-62 dBm	-1	-	-	dB
	65 Mbps OFDM	-61 dBm	-2	-	-	dB
Alternate adjacent channel rejection (Difference between interfering and desired signal (40 MHz apart) at 10% PER for 1000 ^c octet PSDU with desired signal level as specified in Condition/Notes)	6 Mbps OFDM	-78.5 dBm	32	-	-	dB
	9 Mbps OFDM	-77.5 dBm	31	-	-	dB
	12 Mbps OFDM	-75.5 dBm	29	-	-	dB
	18 Mbps OFDM	-73.5 dBm	27	-	-	dB
	24 Mbps OFDM	-70.5 dBm	24	-	-	dB
	36 Mbps OFDM	-66.5 dBm	20	-	-	dB
	48 Mbps OFDM	-62.5 dBm	16	-	-	dB
54 Mbps OFDM	-61.5 dBm	15	-	-	dB	
65 Mbps OFDM	-60.5 dBm	14	-	-	dB	
Maximum receiver gain	-	-	100	-	dB	
Gain control step	-	-	3	-	dB	
RSSI accuracy ^d	Range -98 dBm to -30 dBm	-5	-	5	dB	
	Range above -30 dBm	-8	-	8	dB	
Return loss	Z _o = 50Ω	10	14	-	dB	

- Derate by 1.5 dB for -30 °C to -10°C and 55°C to 85°C.
- The cellular standard listed for each band indicates the type of modulation used to generate the interfering signal in that band for the purpose of this test. It is not intended to indicate any specific usage of each band in any specific country.
- For 65 Mbps, the size is 4096.
- The minimum and maximum values shown have a 95% confidence level.

Not Recommended for New Designs

WLAN 5 GHz Transmitter Performance Specifications



Note: The specifications in [Table 37](#) are measured at the chip port, unless otherwise specified.

Table 37: WLAN 5 GHz Transmitter Performance Specifications

Parameter	Condition/Notes		Minimum	Typical	Maximum	Unit
Frequency range	–		4900	–	5845	MHz
Transmitted power in cellular and FM bands (at 18 dBm) ^a	76–108 MHz	FM Rx	–	–162	–	dBm/Hz
	776–794 MHz	–	–	–162	–	dBm/Hz
	869–960 MHz	cdmaOne, GSM850	–	–162	–	dBm/Hz
	925–960 MHz	E-GSM	–	–162	–	dBm/Hz
	1570–1580 MHz	GPS	–	–162	–	dBm/Hz
	1805–1880 MHz	GSM1800	–	–162	–	dBm/Hz
	1930–1990 MHz	GSM1900, cdmaOne, WCDMA	–	–162	–	dBm/Hz
	2110–2170 MHz	WCDMA	–	–162	–	dBm/Hz
2400–2483 MHz	BT/WLAN	–	–162	–	dBm/Hz	
Harmonic level (at 17 dBm)	9.8–11.570 GHz	2nd harmonic	–	–31	–	dBm/MHz
EVM Does Not Exceed						
Tx power for highest power level setting at 25°C, VBATT = 3.6V and spectral mask and EVM compliance ^b	OFDM, BPSK	–8 dB	–	14	–	dBm
	OFDM, 64-QAM (R = 3/4)	–25 dB	–	14	–	dBm
	OFDM, 64-QAM (R = 5/6)	–28 dB	–	12.5	–	dBm
Tx power control dynamic range	–		10	–	–	dB
Tx power control resolution	–		0.5	–	–	dB
Closed loop Tx power variation at highest power level setting	Across full temperature and voltage range		–	–	±2	dB
Carrier suppression	–		15	–	–	dBc
Gain control step	–		–	0.25	–	dB
Return loss	Zo = 50Ω		–	6	–	dB

Not Recommended for New Designs

Table 37: WLAN 5 GHz Transmitter Performance Specifications (Cont.)

Parameter	Condition/Notes	Minimum	Typical	Maximum	Unit	
Load pull variation for output power, EVM, and Adjacent Channel Power Ratio (ACPR)	2:1	EVM degradation	–	3.5	–	dB
		Output power variation	–	±1.5	–	dB
		ACPR-compliant power level	–	15	–	dBm
	3:1	EVM degradation	–	3.5	–	dB
		Output power variation	–	±1.5	–	dB
		ACPR-compliant power level	–	15	–	dBm

- a. The cellular standards listed indicate only typical usages of that band in some countries. Other standards may also be used within those bands.
- b. Derate by 1.5 dB for –30 °C to –10°C and 55°C to 85°C.

General Spurious Emissions Specifications

Table 38: General Spurious Emissions Specifications

Parameter	Condition/Notes	Min	Typ	Max	Unit
Frequency range	–	2400	–	2500	MHz
General Spurious Emissions					
Tx Emissions	30 MHz < f < 1 GHz RBW = 100 kHz	–	–	–62	dBm
	1 GHz < f < 12.75 GHz RBW = 1 MHz	–	–	–47	dBm
	1.8 GHz < f < 1.9 GHz RBW = 1 MHz	–	–	–53	dBm
	5.15 GHz < f < 5.3 GHz RBW = 1 MHz	–	–	–53	dBm
Rx/standby Emissions	30 MHz < f < 1 GHz RBW = 100 kHz	–	–78	–63	dBm
	1 GHz < f < 12.75 GHz RBW = 1 MHz	–	–68.5 ^a	–53	dBm
	1.8 GHz < f < 1.9 GHz RBW = 1 MHz	–	–96	–53	dBm
	5.15 GHz < f < 5.3 GHz RBW = 1 MHz	–	–96	–53	dBm

- a. For frequencies other than 3.2 GHz, the emissions value is –96 dBm. The value presented in table is the result of LO leakage at 3.2 GHz.

Section 20: Internal Regulator Electrical Specifications



Note: Values in this data sheet are design goals and are subject to change based on the results of device characterization.

Functional operation is not guaranteed outside of the specification limits provided in this section.

Core Buck Regulator

Table 39: Core Buck Regulator (CBLUCK) Specifications

Specification	Notes	Minimum	Typical	Maximum	Units
Input supply voltage	–	2.3	–	4.8 ^a	V
Input supply voltage ramp-up time	0–4.3V	40	–	–	μs
PWM mode switching frequency	–	2.56	3.2	3.84	MHz
PWM output current	–	–	–	500	mA
PWM load regulation ^b	10 mA to a 500 mA load	–	–	±30	mV
PWM line regulation ^b	10 mA to a 500 mA load	–	–	±10	mV
Output voltage range (default = 1.5V)	Programmable, 33.33 mV steps	1.2	1.5	1.8	V
Output voltage accuracy ^c	–	–5	–	5	%
PWM ripple voltage, static load ^d	Measured with a 20 MHz bandwidth limit.	–	7	20	mVpp
Burst mode ripple voltage, static	<30 mA load current, measured with a 20 MHz bandwidth limit.	–	–	80	mVpp
Peak PWM mode efficiency ^e	200 mA load current	80	90	–	%
Burst mode efficiency ^e	5 mA load current	70	80	–	%
Output current limit	–	–	700	–	mA
External input capacitor ^f	Cap–ESR <4 mΩ at 3.2 MHz, 6.3V, X5R, Ceramic, 0603/0402, ±20%	–	4.7	–	μF
External output capacitor ^f	Cap–ESR <4 mΩ at 3.2 MHz, 6.3V, X5R, Ceramic, 0603/0402, ±20%	–	4.7	–	μF
External output inductor ^f	LQM2MPN2R2NG0 2.2 μH ±30% DCR = 110 mΩ ±25%, ACR <1Ω. Isat = 1A (based on L-30%)	–	2.2	–	μH

Not Recommended for New Designs

Table 39: Core Buck Regulator (CBUCK) Specifications

Specification	Notes	Minimum	Typical	Maximum	Units
Start-up time from power down ^g	–	–	–	1400	μs
<p>a. The max continuous voltage is 4.8V. Voltages up to 5.5V for up to 10 seconds, cumulative duration, over the lifetime of the device are allowed. Voltages as high as 5.0V for up to 250 seconds, cumulative duration, over the lifetime of the device are allowed.</p> <p>b. VBAT = 2.7 to 4.8V, inductor DCR <137.5 mΩ</p> <p>c. Includes line/load regulation, VBAT = 2.7 to 4.8V, load 0 to 500 mA, inductor DCR <137.5 mΩ</p> <p>d. Max ripple based on VBAT <4.3V, Vout = 1.5V, Fs = 3.2 MHz, 1.5 uH inductor L >1.05 uH, cap + board total–ESR <10 mΩ, Cout > 1.9 uF</p> <p>e. VBAT<4.3V, inductor DCR <137.5 mΩ, ACR <1Ω</p> <p>f. Critical CBuck component–see Reference [1] on page 20 for details and required characteristics of external PMU components.</p> <p>g. Start-up time is measured with respect to the rising edge of BT_REG_ON, WL_REG_ON, or EXT_SMPS_REQ.</p>					

LDO3p1

Table 40: LDO3p1 Specifications

Specification	Notes	Minimum	Typical	Maximum	Units
Input supply voltage	–	2.3	3.6	4.8 ^a	V
Output current	–	–	–	80	mA
Output voltage range (default = 2.5V)	Programmable, 100 mV steps	2.4	2.5	3.4	V
Output voltage accuracy ^b	Includes line/load regulation	–5	–	5	%
Drop-out voltage	At maximum load	–	–	200	mV
Quiescent current	No load	–	8	–	μA
External output capacitor ^{cd}	–	–	2.2	–	μF
External input capacitor ^c	SR_VDDBAT2 pin, ceramic, X5R, 0402, ESR 30–200 mΩ, ±10%, 10V	–	1	–	μF
Start-up time from power down	–	–	–	1400	μs
LDO turn-on time	Chip already powered up	–	–	100	μs
<p>a. The max continuous voltage is 4.8V. Voltages up to 5.5V for up to 10 seconds, cumulative duration, over the lifetime of the device are allowed. Voltages as high as 5.0V for up to 250 seconds, cumulative duration, over the lifetime of the device are allowed.</p> <p>b. VBAT = 2.7 to 4.8V for 2.5V VOUT.</p> <p>c. See Reference [1] on page 20 for details and required characteristics of external PMU components.</p> <p>d. Ceramic, X5R, 0402, ESR 30~200 mΩ, ±10%, 10V.</p>					

LDO3p3

Table 41: LDO3p3 Specifications

Specification	Notes	Minimum	Typical	Maximum	Units
Input supply voltage	–	2.3	3.6	4.8 ^a	V
Output current	–	–	–	80	mA
Output voltage range (default = 3.3V)	Programmable, 100 mV steps	2.4	3.3	3.4	V
Output voltage accuracy ^b	Includes line/load regulation	–5	–	5	%
Drop-out voltage	At maximum load	–	–	200	mV
Quiescent current	No load	–	8	–	μA
External output capacitor ^{cd}	–	–	4.7	–	μF
External input capacitor ^d	SR_VDDBAT2 pin, ceramic, X5R, 0402, ESR 30–200 mΩ, ±10%, 10V	–	1	–	μF
Start-up time from power-down	–	–	500	1000	μs
LDO turn-on time	Chip already powered up	–	–	100	μs

- The max continuous voltage is 4.8V. Voltages up to 5.5V for up to 10 seconds, cumulative duration, over the lifetime of the device are allowed. Voltages as high as 5.0V for up to 250 seconds, cumulative duration, over the lifetime of the device are allowed.
- V_{BAT} = 3.5 to 4.8V for 3.3V V_{OUT}.
- ESR: 30–200 mΩ
- See [Reference \[1\] on page 20](#) for details and required characteristics of external PMU components.

Not Recommended for New Designs

CLDO

Table 42: CLDO Specifications

Specification	Notes	Minimum	Typical	Maximum	Units
Input supply voltage, V_{in}	–	1.425	1.5	2.0	V
Output voltage (default = 1.25V)	Programmable in 25 mV steps	1.075	1.25	1.325	V
Output voltage accuracy	Includes line/load regulation $V_{in} > V_o + 0.2V$	–	–	±4	%
Dropout voltage	At maximum load	–	–	200	mV
Output current	–	–	–	150	mA
Quiescent current	–	–	10	15	µA
Leakage current through output transistor	CLDO_pu = 0	–	1	3	µA
Power supply rejection (PSR)	@1 kHz, $V_{in} > 1.5V$, $C_{out} = 4.7 \mu F$	–	40	–	dB
Output capacitor ^a	Ceramic, X5R, 0402, ESR: 30–200 mΩ, ±10%, 10V	–	4.7	–	µF
External input capacitor ^a	Only use an external input capacitor – at VDD_LDO if it is not supplied from the CBUCK output. Ceramic, X5R, 0402, ESR 30–200 mΩ, ±10%, 10V	–	1	–	µF
Start-up time	From power-down	–	–	1400	µs
LDO turn-on time	Chip already powered up	–	–	180	µs

a. See [Reference \[1\]](#) on [page 20](#) for details and required characteristics of external PMU components.

LNLDO1

Table 43: LNLDO1 Specifications^a

Specification	Notes	Minimum	Typical	Maximum	Units
Input Supply Voltage	–	1.425	1.5	2.0	V
Output Voltage (default = 1.25V)	Programmable in 25 mV steps	1.10	1.25	1.35	V
Output Voltage Accuracy ^b	–	–	–	± 4	%
Output Current	–	–	–	300	mA
Dropout Voltage (at max load)	–	–	–	200	mV
Quiescent Current	–	–	62	88	μA
Leakage Current	–	–	0.1	10	μA
Output Noise	@ 30 kHz, 60 mA load	–	–	60	nV/rt Hz
PSR	@ 1 kHz, Vin >1.5V, Cout = 4.7 μF	–	50	–	dB
External Output Capacitor	Ceramic, X5R, 0402, ESR 30–200 mΩ, ±10%, 10V	–	4.7	–	μF
Start-up time	–	–	–	1400	μs
LDO Turn-on Time	Chip already powered up	–	–	180	μs

a. See [Reference \[1\] on page 20](#) for details and required characteristics of external PMU components.

b. Include line/load regulation, Vin >Vo + 0.2V

Not Recommended for New Designs

Section 21: System Power Consumption



Note: Values in this data sheet are design goals and are subject to change based on the results of device characterization.

Unless otherwise stated, these values apply for the conditions specified in [Table 27: “Recommended Operating Conditions and DC Characteristics,”](#) on page 119.

Not Recommended for New Designs

WLAN Current Consumption

The WLAN current consumption measurements are shown in [Table 44](#).

All values in [Table 44](#) are with the Bluetooth core in reset (that is, Bluetooth and FM are off).

Table 44: WLAN Power Consumption (Ivbat+Ivio)

WLAN	VBATT = 3.6V, VDDIO = 1.8V, T _A 25°C	
	Typical Total	Units
OFF ^a	10	μA
SLEEP ^b	180	μA
Power Save ^{c, d}	1.25	mA
Rx (Listen) ^e	52	mA
Rx (Active) ^{f, g}	60	mA
Tx CCK (21 dBm @ chip) ^{h, i}	325	mA
Tx OFDM, 54 Mbps (21 dBm @ chip) ^{h, i}	325	mA
Tx MCS7 (20 dBm @ chip) ^{h, i}	300	mA

- WL_REG_ON = Low, no VDDSI0
- Inter-beacon Sleep
- Beacon Interval = 102.4 ms, DTIM = 1, Beacon duration = 1 ms @1 Mbps. Integrated Sleep + wakeup + Beacon Rx current over 1 DTIM interval.
- In WLAN power save mode, the following blocks are powered down: Crystal oscillator, Baseband PLL, AFE, RF PLL, and the WLAN radio.
The above blocks are turned on in the required order with sufficient time for them to settle. This sequencing is done by the PMU controller, which controls the settling time for each of the blocks. It also has information to determine the order in which the blocks should be turned on. The settling times and the dependency order are programmable in the PMU controller. The default CLK settling time is set to 8 ms at power-up. It can be reduced after power-up.
Response: Total current consumption (at 20°C) from VBATT = 3.6V when waking up from doze for beacon reception:
Sleep mode: 180 μA
Turn on XO (~3–4 ms earlier): 3–5 mA
Turn on BBPLL (~1 ms earlier): 10 mA
Run BB on full clock (~1 ms earlier): 28 mA
Turn on RFPLL(~1 ms earlier): 35 mA
Turn on Radio–Listen (~1 ms earlier): 52 mA
Beacon reception: 60 mA
Back to sleep mode: 180 μA
- Carrier sense (CCA) when no carrier present.
- Carrier sense (CS) detect/packet Rx.
- Applicable to all supported rates.
- Duty cycle is 100%. Includes PA contribution at 3.6V.
- Absolute junction temperature limits are maintained through active thermal monitoring and dynamic Tx duty cycle limiting.

HSIC Power Consumption

The HSIC power consumption measurements are shown in [Table 45](#).

Table 45: HSIC Power Consumption

State	Typical Current in mA (AVDD+DVDD @ 1.2V)
Standby	0.012
Active, Idle	10.12
Active, Worst case pattern	18.22

Not Recommended for New Designs

Bluetooth and FM Current Consumption

The Bluetooth and FM current consumption measurements are shown in [Table 46](#).



Note: The WLAN core is in reset (WLAN_RST_N = low) for all measurements provided in [Table 46](#).



Note: For FM measurements, the Bluetooth core is in sleep mode. The current consumption numbers are measured based on the typical output power as specified in [Table 29 on page 123](#).

Table 46: Bluetooth and FM Current Consumption

<i>Operating Mode</i>	<i>VBATT (VBATT = 3.6V) Typical</i>	<i>VDDIO (VDDIO = 1.8V) Typical</i>	<i>Units</i>
Sleep	0.14	0.15	mA
Standard 1.28s Inquiry Scan	0.34	–	mA
3DH5/3DH1 Master	24.8	–	mA
3DH5/3DH1 Slave	24.8	–	mA
HV3 + Sniff + Scan ^a	14.2	–	mA
P & I Scan ^b	529	5	μA
500 ms Sniff Master	0.24	–	mA
500 ms Sniff Slave	0.24	–	mA
DM1/DH1 Master	32	–	mA
DM3/DH3 Master	40	–	mA
DM5/DH5 Master	41	–	mA
FMRX I ² S Audio	14.7	–	mA
FMRX Analog Audio	15.3	–	mA

- a. At maximum class 1 TX power, 500 ms sniff, four attempts (slave), P = 1.28s, and I = 2.56s.
 b. 1.28s page/inquiry scan interval.

Section 22: Interface Timing and AC Characteristics

SDIO/gSPI Timing

SDIO Default Mode Timing

SDIO default mode timing is shown by the combination of [Figure 44](#) and [Table 47](#) on page 153.

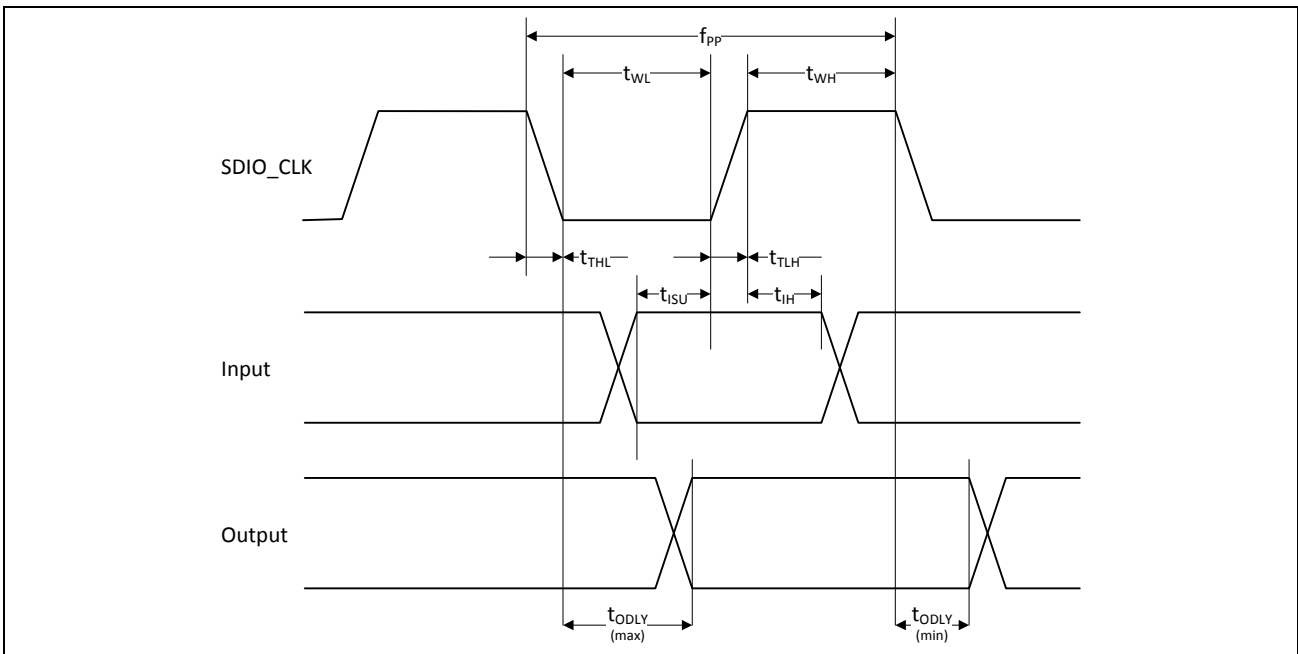

Figure 44: SDIO Bus Timing (Default Mode)

Not Recommended for New Designs

Table 47: SDIO Bus Timing^a Parameters (Default Mode)

Parameter	Symbol	Minimum	Typical	Maximum	Unit
SDIO CLK (All values are referred to minimum VIH and maximum VIL^b)					
Frequency – Data Transfer mode	fPP	0	–	25	MHz
Frequency – Identification mode	fOD	0	–	400	kHz
Clock low time	tWL	10	–	–	ns
Clock high time	tWH	10	–	–	ns
Clock rise time	tTLH	–	–	10	ns
Clock low time	tTHL	–	–	10	ns
Inputs: CMD, DAT (referenced to CLK)					
Input setup time	tISU	5	–	–	ns
Input hold time	tIH	5	–	–	ns
Outputs: CMD, DAT (referenced to CLK)					
Output delay time – Data Transfer mode	tODLY	0	–	14	ns
Output delay time – Identification mode	tODLY	0	–	50	ns

- a. Timing is based on $CL \leq 40\text{pF}$ load on CMD and Data.
b. $\min(V_{ih}) = 0.7 \times V_{DDIO}$ and $\max(V_{il}) = 0.2 \times V_{DDIO}$.

SDIO High-Speed Mode Timing

SDIO high-speed mode timing is shown by the combination of Figure 45 and Table 48.

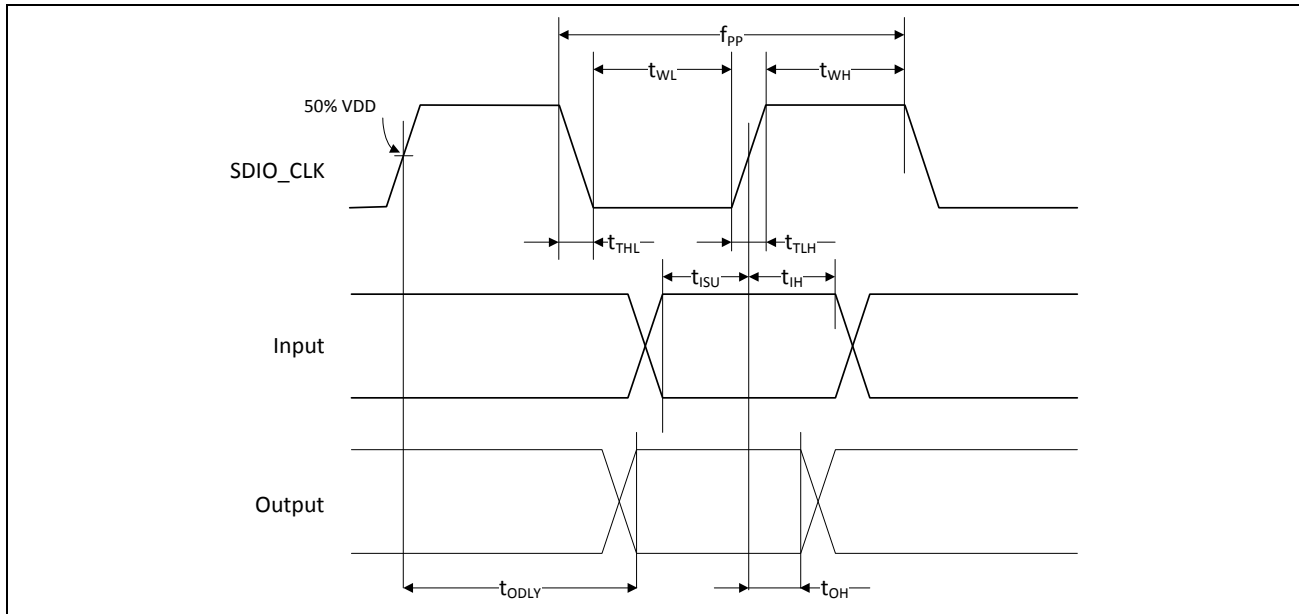

Figure 45: SDIO Bus Timing (High-Speed Mode)

Table 48: SDIO Bus Timing^a Parameters (High-Speed Mode)

Parameter	Symbol	Minimum	Typical	Maximum	Unit
SDIO CLK (all values are referred to minimum VIH and maximum VIL^b)					
Frequency – Data Transfer Mode	f _{PP}	0	–	50	MHz
Frequency – Identification Mode	f _{OD}	0	–	400	kHz
Clock low time	t _{WL}	7	–	–	ns
Clock high time	t _{WH}	7	–	–	ns
Clock rise time	t _{TLH}	–	–	3	ns
Clock low time	t _{THL}	–	–	3	ns
Inputs: CMD, DAT (referenced to CLK)					
Input setup Time	t _{ISU}	6	–	–	ns
Input hold Time	t _{IH}	2	–	–	ns
Outputs: CMD, DAT (referenced to CLK)					
Output delay time – Data Transfer Mode	t _{ODLY}	–	–	14	ns
Output hold time	t _{OH}	2.5	–	–	ns
Total system capacitance (each line)	CL	–	–	40	pF

a. Timing is based on CL ≤ 40pF load on CMD and Data.
 b. min(V_{IH}) = 0.7 × V_{DDIO} and max(V_{IL}) = 0.2 × V_{DDIO}.

Not Recommended for New Designs

gSPI Signal Timing

The gSPI host and device always use the rising edge of clock to sample data.

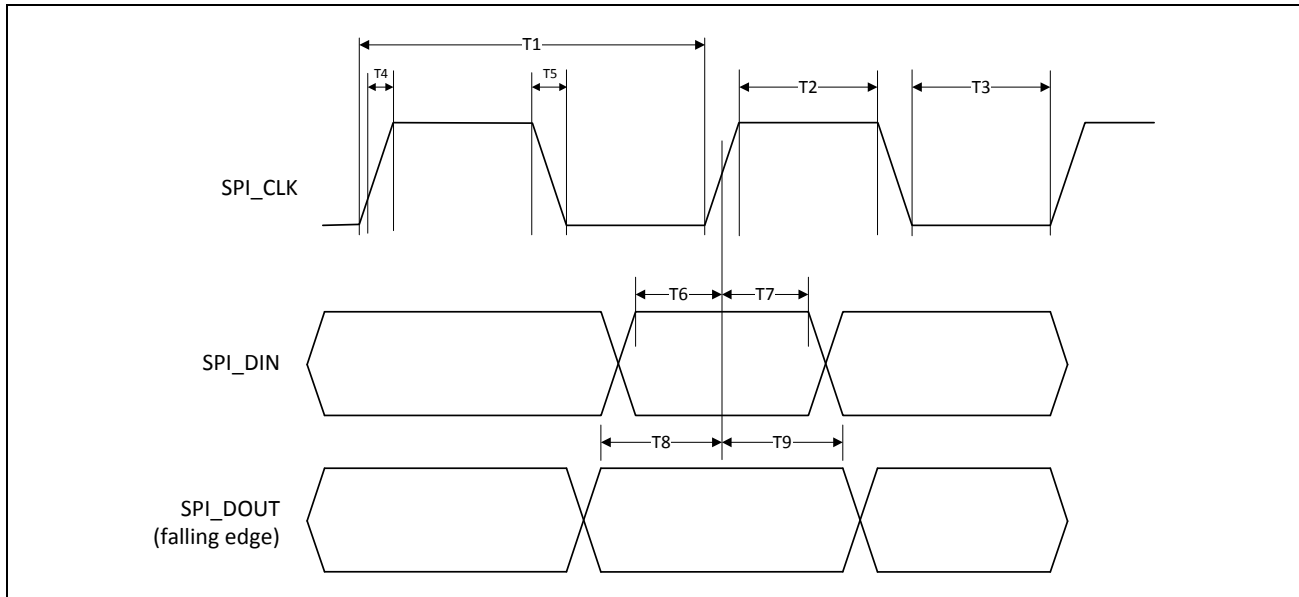

Figure 46: gSPI Timing

Table 49: gSPI Timing Parameters

Parameter	Symbol	Minimum	Maximum	Units	Note
Clock period	T1	20.8	–	ns	$F_{max} = 48 \text{ MHz}$
Clock high/low	T2/T3	$(0.45 \times T1) - T4$	$(0.55 \times T1) - T4$	ns	–
Clock rise/fall time	T4/T5	–	2.5	ns	–
Input setup time	T6	5.0	–	ns	Setup time, SIMO valid to SPI_CLK active edge
Input hold time	T7	5.0	–	ns	Hold time, SPI_CLK active edge to SIMO invalid
Output setup time	T8	5.0	–	ns	Setup time, SOMI valid before SPI_CLK rising
Output hold time	T9	5.0	–	ns	Hold time, SPI_CLK active edge to SOMI invalid
CSX to clock ^a	–	7.86	–	ns	CSX fall to 1st rising edge
Clock to CSX ^a	–	–	–	ns	Last falling edge to CSX high

a. SPI_CSx remains active for entire duration of gSPI read/write/write_read transaction (i.e., overall words for multiple word transaction)

HSIC Interface Specifications

Table 50: HSIC Timing Parameters

Parameter	Symbol	Minimum	Typical	Maximum	Unit	Comments
HSIC signaling voltage	V_{DD}	1.1	1.2	1.3	V	–
I/O voltage input low	V_{IL}	–0.3	–	$0.35 \times V_{DD}$	V	–
I/O Voltage input high	V_{IH}	$0.65 \times V_{DD}$	–	$V_{DD} + 0.3$	V	–
I/O voltage output low	V_{OL}	–	–	$0.25 \times V_{DD}$	V	–
I/O voltage output high	V_{OH}	$0.75 \times V_{DD}$	–	–	V	–
I/O pad drive strength	O_D	40	–	60	Ω	Controlled output impedance driver
I/O weak keepers	I_L	20	–	70	mA	–
I/O input impedance	Z_I	100	–	–	k Ω	–
Total capacitive load ^a	C_L	3	–	14	pF	–
Characteristic trace impedance	T_I	45	50	55	Ω	–
Circuit board trace length	T_L	–	–	10	cm	–
Circuit board trace propagation skew ^b	T_S	–	–	15	ps	–
STROBE frequency ^c	F_{STROBE}	239.988	240	240.012	MHz	± 500 ppm
Slew rate (rise and fall) STROBE and DATA ^c	T_{slew}	$0.60 \times V_{DD}$	1.0	1.2	V/ns	Averaged from 30% ~ 70% points
Receiver data setup time (with respect to STROBE) ^c	T_s	300	–	–	ps	Measured at the 50% point
Receiver data hold time (with respect to STROBE) ^c	T_b	300	–	–	ps	Measured at the 50% point

- Total Capacitive Load (C_L), includes device Input/Output capacitance, and capacitance of a 50 Ω PCB trace with a length of 10 cm.
- Maximum propagation delay skew in STROBE or DATA with respect to each other. The trace delay should be matched between STROBE and DATA to ensure that the signal timing is within specification limits at the receiver.
- Jitter and duty cycle are not separately specified parameters, they are incorporated into the values in the table above.

Not Recommended for New Designs

JTAG Timing

Table 51: JTAG Timing Characteristics

<i>Signal Name</i>	<i>Period</i>	<i>Output Maximum</i>	<i>Output Minimum</i>	<i>Setup</i>	<i>Hold</i>
TCK	125 ns	–	–	–	–
TDI	–	–	–	20 ns	0 ns
TMS	–	–	–	20 ns	0 ns
TDO	–	100 ns	0 ns	–	–
JTAG_TRST	250 ns	–	–	–	–

Not Recommended for New Designs

Section 23: Power-Up Sequence and Timing

Sequencing of Reset and Regulator Control Signals

The BCM4330 has three signals that allow the host to control power consumption by enabling or disabling the Bluetooth, WLAN, and internal regulator blocks. These signals are described below. Additionally, diagrams are provided to indicate proper sequencing of the signals for various operational states (see [Figure 47 on page 159](#), [Figure 48 on page 160](#), [Figure 49 on page 160](#) and [Figure 50 on page 161](#)). The timing values indicated are the minimum required values; longer delays are also acceptable.



Note: The WL_REG_ON and BT_REG_ON signals are ORed in the BCM4330. The diagrams show both signals going high at the same time (as would be the case if both REG signals were controlled by a single host GPIO). If two independent host GPIOs are used (one for WL_REG_ON and one for BT_REG_ON), then only one of the two signals needs to be high to enable the BCM4330 regulators.

Also note that the reset requirements for the Bluetooth core are also applicable for the FM core. In other words, if FM is to be used, then the Bluetooth core must be enabled.



Note: The BCM4330 has an internal power-on reset (POR) circuit. The device will be held in reset for a maximum of 110 ms after VDDC and VDDIO have both passed the 0.6V threshold. Wait at least 150 ms after VDDC and VDDIO are available before initiating SDIO accesses. The external reset signals are logically ORed with this POR. So if either the internal POR or one of the external resets is asserted, the device will be in reset.

If VDDIO goes LOW, all regulators (including bandgap reference) will be powered OFF immediately, regardless of the status of the WL_REG_ON, BT_REG_ON, and EXT_SMPS_REQ pins.

Description of Control Signals

- WL_REG_ON:** Used by the PMU to power up the WLAN section. It is also OR-gated with the BT_REG_ON input to control the internal BCM4330 regulators. When this pin is high, the regulators are enabled and the WLAN section is out of reset. When this pin is low the WLAN section is in reset. A “warm” WLAN reset can be initiated by driving WL_REG_ON low for at least 10 microseconds (see [Figure 51 on page 161](#)). If both the BT_REG_ON and WL_REG_ON pins are low, the regulators are disabled. Logic High Level: 1.08V–3.6V. 200k pull-down resistor included.
- BT_REG_ON:** Used by the PMU (OR-gated with WL_REG_ON) to power up the internal BCM4330 regulators. If both the BT_REG_ON and WL_REG_ON pins are low, the regulators are disabled. Logic High Level: 1.08V–3.6V. 200k pull-down resistor included.
- BT_RST_N:** Low asserting reset for Bluetooth and FM only. This pin has no effect on WLAN and does not control any PMU functions. This pin must be driven high or low (not left floating).

In addition, two other input signals control PMU modes:

- When EXT_SMPS_REQ is pulled high, it forces CBUCK to stay on, even when the other regulators are shut down by WL_REG_ON or BT_REG_ON.
- When WLAN and/or Bluetooth are out of reset and EXT_SMPS_REQ is high, then pulling EXT_PWM_REQ high makes CBUCK go into PWM mode, even if internal settings from WLAN and/or Bluetooth are requesting burst mode. During such contention, the request for the higher-power mode wins.

Control Signal Timing Diagrams

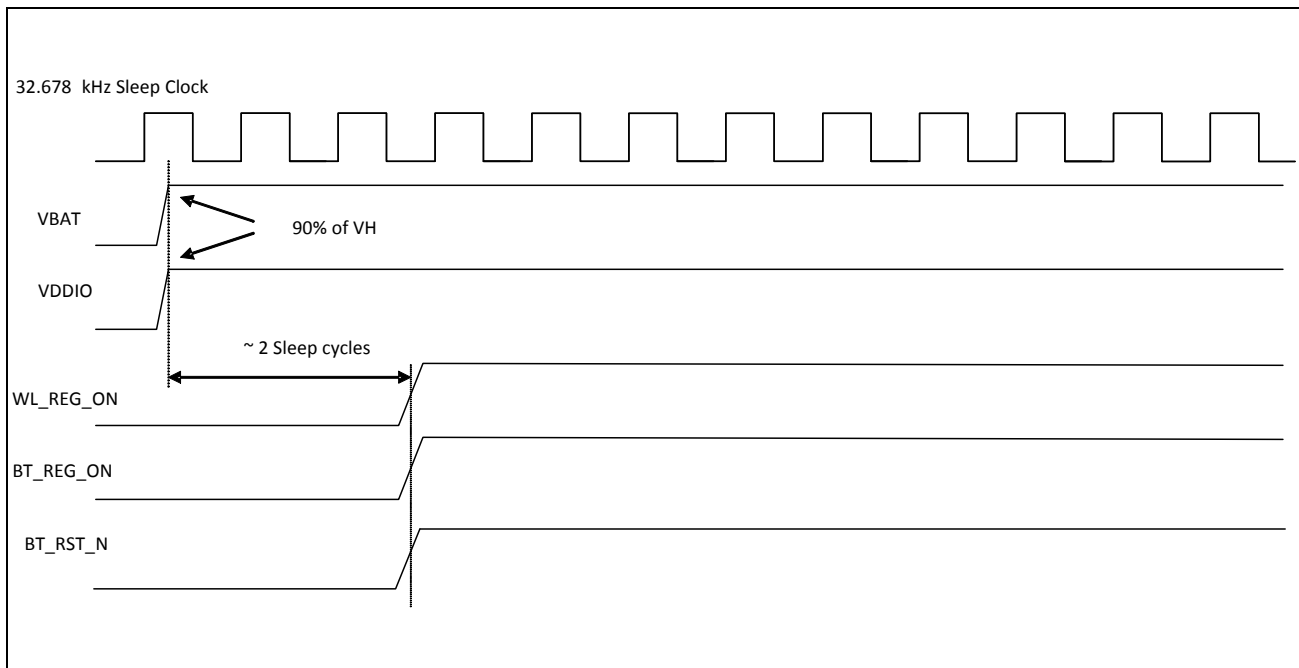

Figure 47: WLAN = ON, Bluetooth = ON

Not Recommended for New Designs

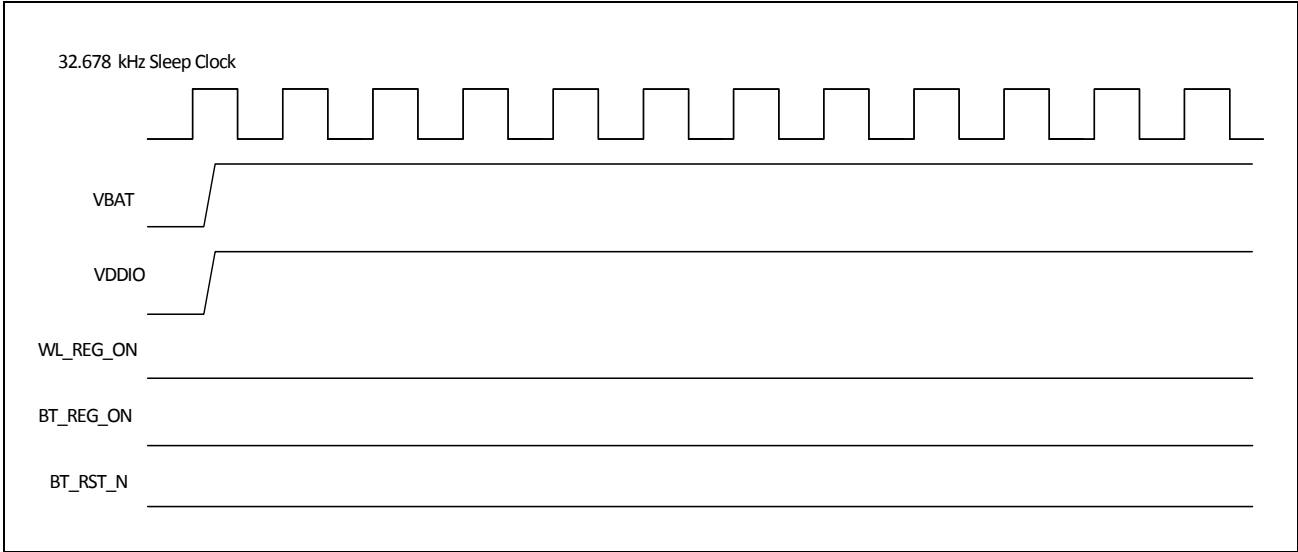

Figure 48: WLAN = OFF, Bluetooth = OFF

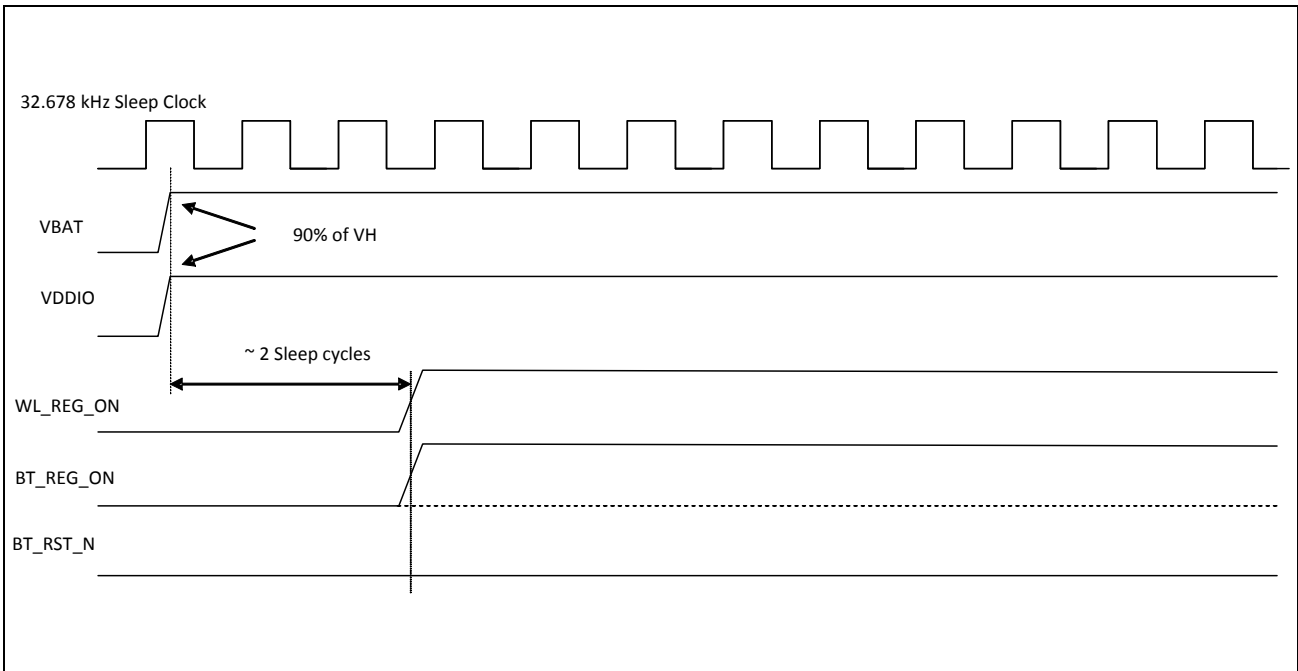

Figure 49: WLAN = ON, Bluetooth = OFF

Not Recommended for New Designs

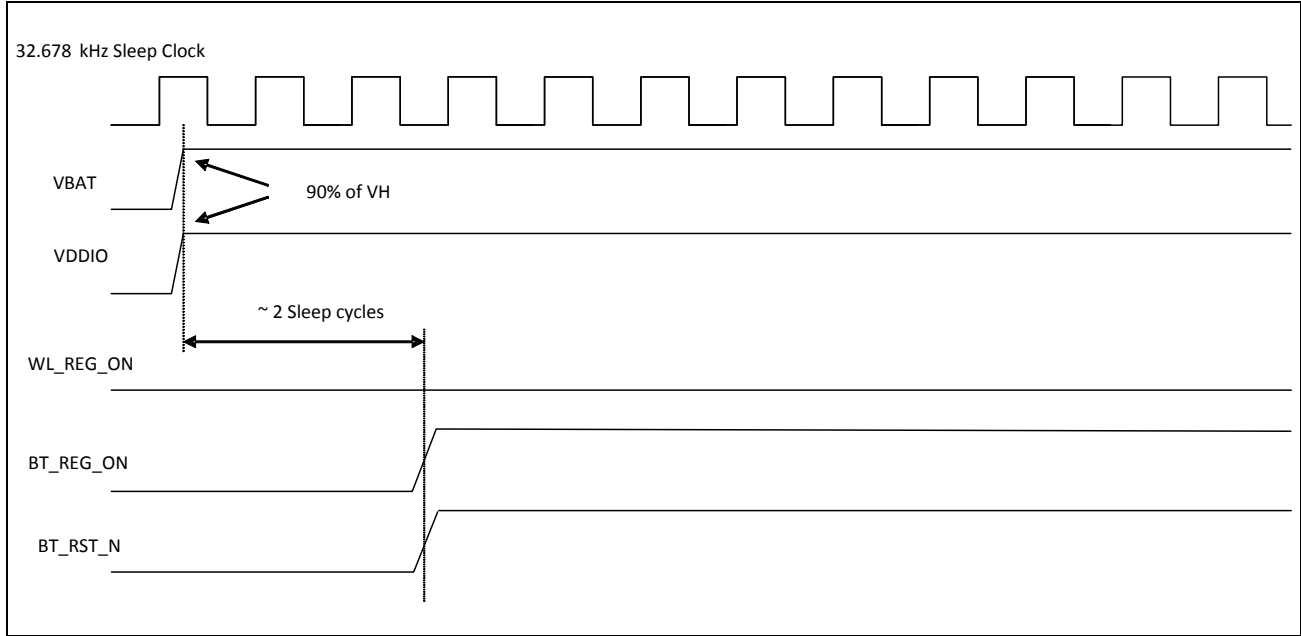

Figure 50: WLAN = OFF, Bluetooth = ON

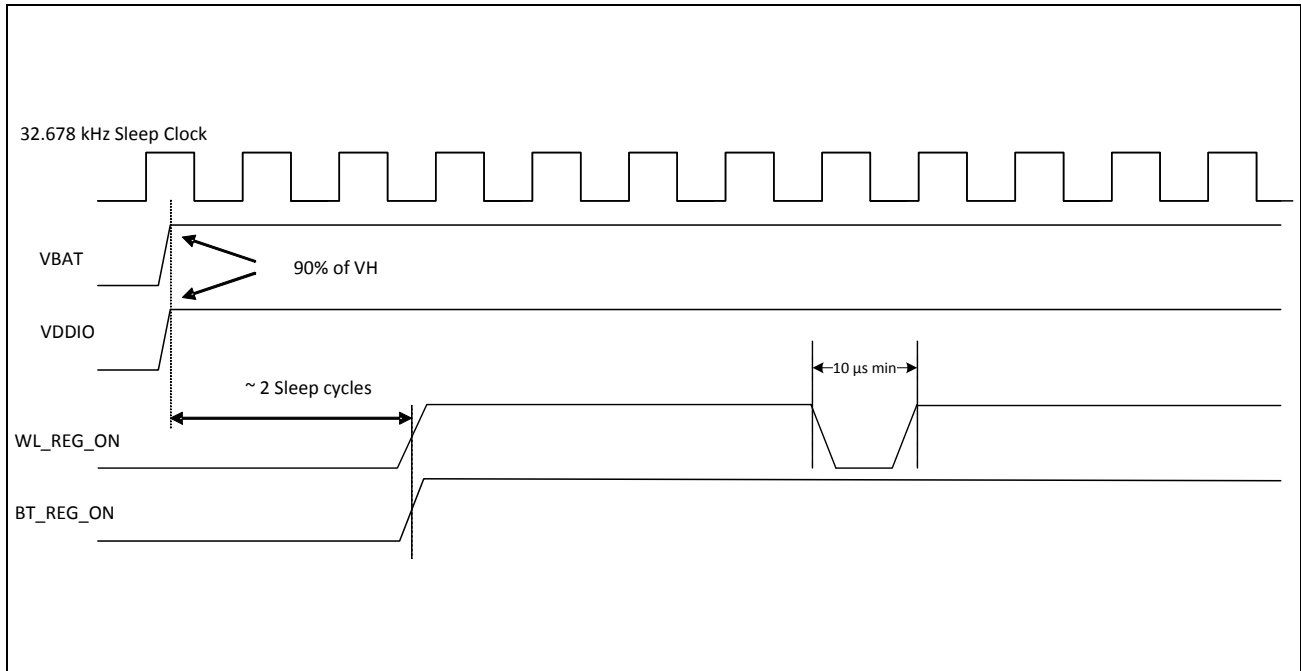

Figure 51: WLAN Warm Reset

Not Recommended for New Designs

Section 24: Package Information

Package Thermal Characteristics

Table 52: Package Thermal Characteristics^a

Characteristic	FCFBGA	WLBGA	WLSCP
θ_{JA} (°C/W) (value in still air)	39.07	33.73	33.24
θ_{JB} (°C/W)	12.31	2.44	2.06
θ_{JC} (°C/W)	13.03	0.61	0.69
Ψ_{JT} (°C/W)	4.55	2.68	2.09
Ψ_{JB} (°C/W)	19.28	11.10	10.85
Maximum Junction Temperature T_J	125°C	125°C	125°C
Maximum Power Dissipation (W)	1.43	1.43	1.43

a. No heat sink, $T_A = 70^\circ\text{C}$. This is an estimate, based on a 2- or 4-layer PCB that conforms to EIA/JESD51-7 (101.6 mm x 114.3 mm x 1.6 mm) and $P = 1.43\text{W}$ continuous dissipation.

Junction Temperature Estimation and Ψ_{JT} Versus θ_{JC}

Package thermal characterization parameter Ψ_{JT} (Ψ_{JT}) yields a better estimation of actual junction temperature (T_J) versus using the junction-to-case thermal resistance parameter θ_{JC} (θ_{JC}). The reason for this is that θ_{JC} assumes that all the power is dissipated through the top surface of the package case. In actual applications, some of the power is dissipated through the bottom and sides of the package. Ψ_{JT} takes into account power dissipated through the top, bottom, and sides of the package. The equation for calculating the device junction temperature is:

$$T_J = T_T + P \times \Psi_{JT}$$

Where:

- T_J = Junction temperature at steady-state condition (°C)
- T_T = Package case top center temperature at steady-state condition (°C)
- P = Device power dissipation (Watts)
- Ψ_{JT} = Package thermal characteristics; no airflow (°C/W)

Environmental Characteristics

For environmental characteristics data, see [Table 25: “Environmental Ratings,” on page 118.](#)

Not Recommended for New Designs

Section 25: Mechanical Information

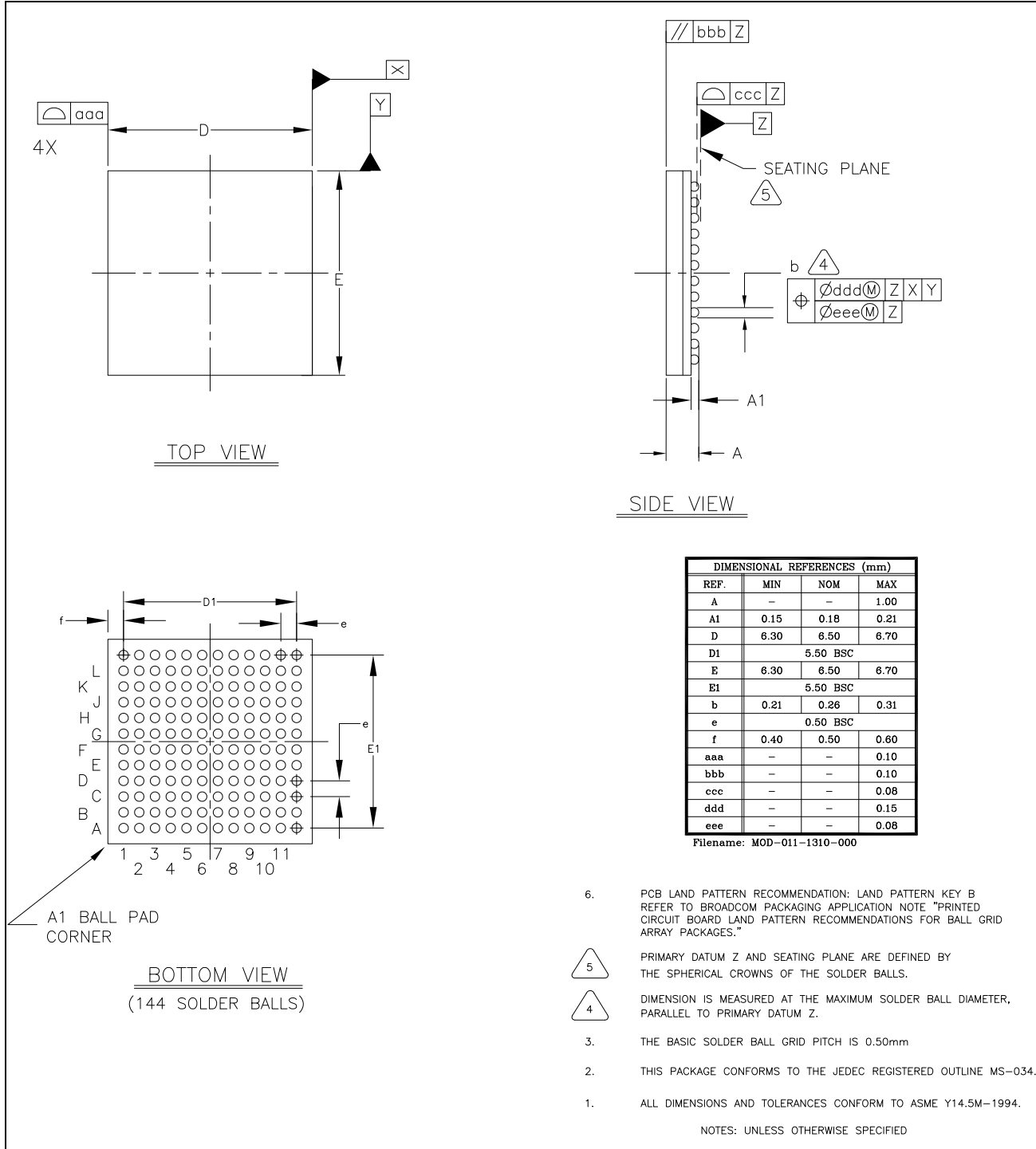

Figure 52: 144-Ball FCBGA Package Mechanical Information

Not Recommended for New Designs

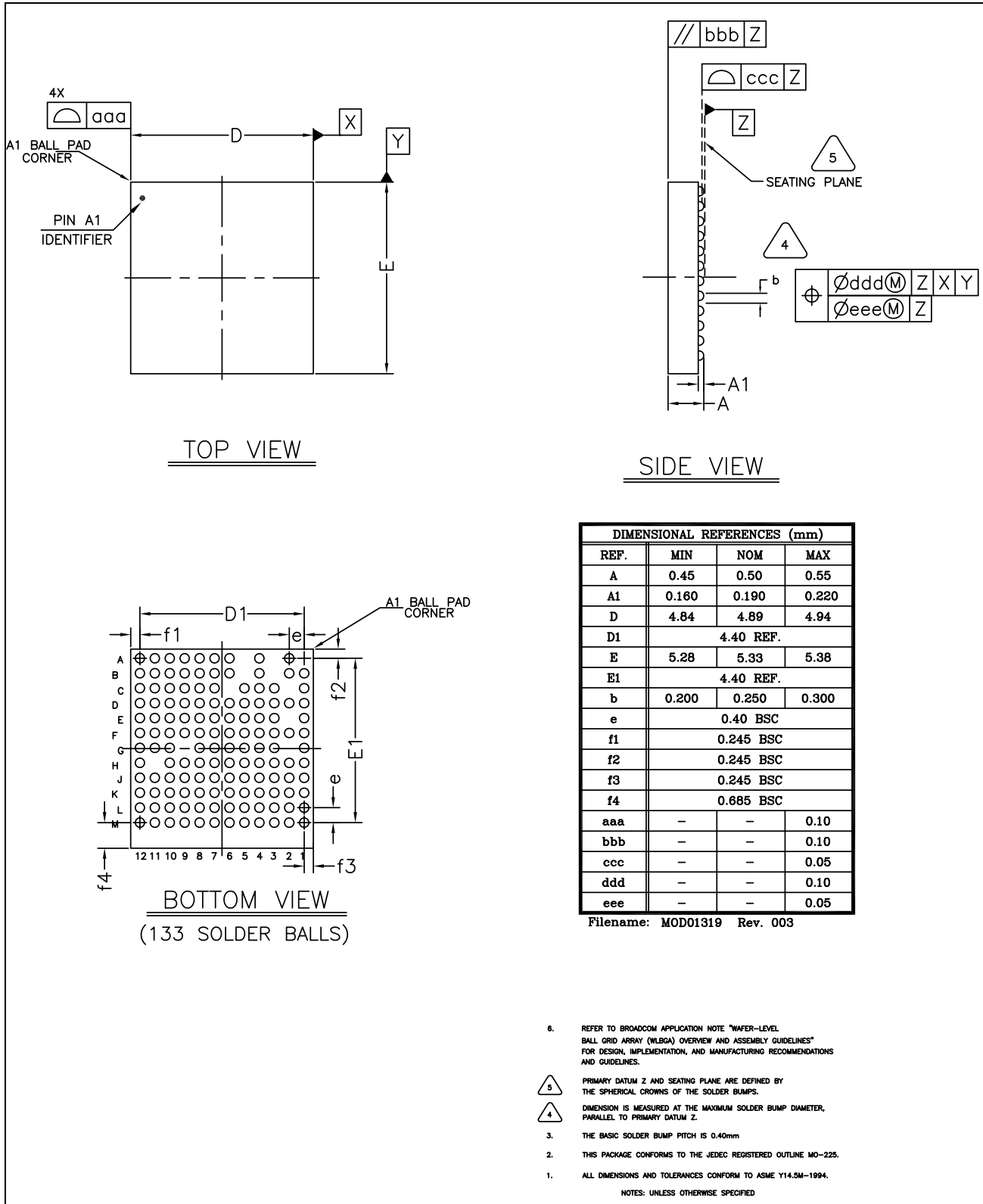

Figure 53: 133-Ball WLBGA Package Mechanical Information

Not Recommended for New Designs

Not Recommended for New Designs

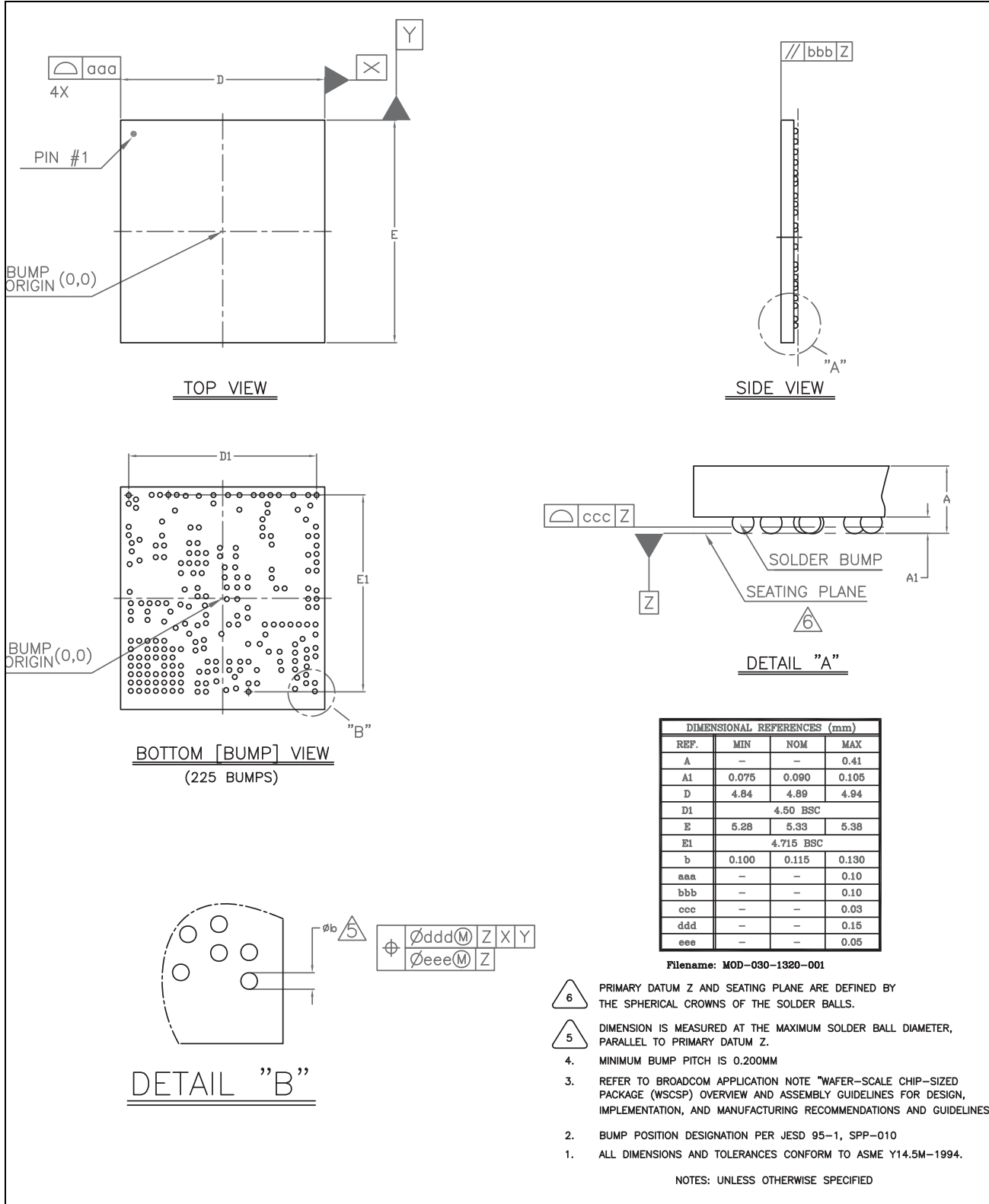

Figure 54: 225-Bump WLCSP Package Mechanical Information

WLCSP Package Keep-Out Area

Figure 55 shows the PCB keep-out areas of the BCM4330 WLCSP package. There should not be any metal in the areas indicated in red on the top PCB layer.

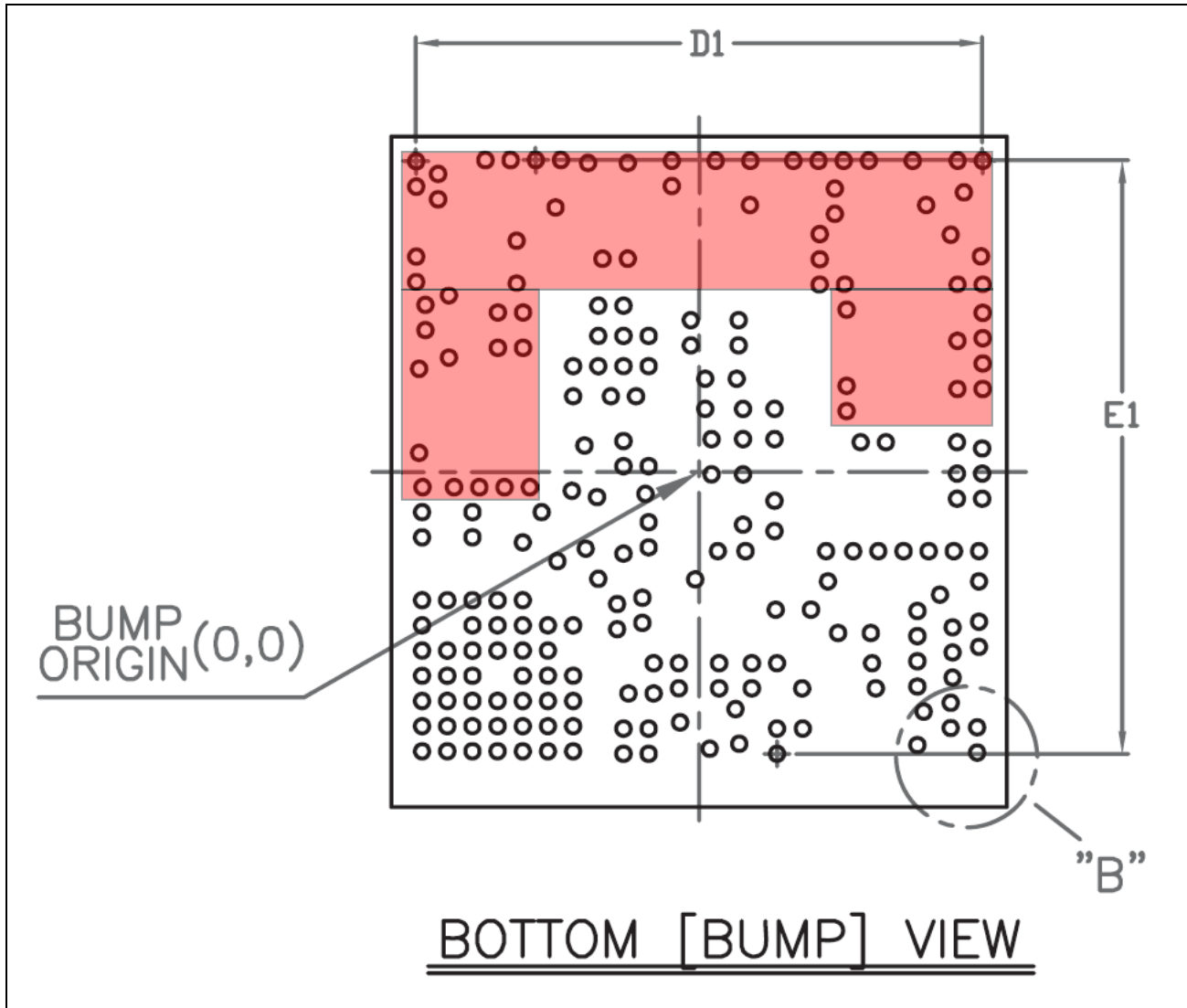

Figure 55: WLCSP Package Keep-outs

Not Recommended for New Designs

Section 26: Ordering Information

Table 53: Ordering Information

Part Number	Package	Description	Operating Ambient Temp
BCM4330FKFFBG	144 ball FCFBGA (6.5 mm x 6.5 mm, 0.5 mm pitch)	Single-band WLAN + BT 4.0 + FM RX	-30°C to +85°C
BCM4330FKUBG	133 ball WLBGA (4.89 mm x 5.33 mm, 0.4 mm pitch)	Single-band WLAN + BT 4.0 + FM RX	-30°C to +85°C
BCM4330FKWBG	225 bump WLCSP (4.89 mm x 5.33 mm, 0.2 mm pitch)	Single-band WLAN + BT 4.0 + FM RX	-30°C to +85°C
BCM4330GKFFBG	144 ball FCFBGA (6.5 mm x 6.5 mm, 0.5 mm pitch)	Single-band WLAN + BT 4.0	-30°C to +85°C
BCM4330GKUBG	133 ball WLBGA (4.89 mm x 5.33 mm, 0.4 mm pitch)	Single-band WLAN + BT 4.0	-30°C to +85°C
BCM4330GKWBG	225 bump WLCSP (4.89 mm x 5.33 mm, 0.2 mm pitch)	Single-band WLAN + BT 4.0	-30°C to +85°C
BCM4330XKUBG	133 ball WLBGA (4.89 mm x 5.33 mm, 0.4 mm pitch)	Dual-band WLAN + BT 4.0 + FM	-30°C to +85°C
BCM4330XKWBG	225 bump WLCSP (4.89 mm x 5.33 mm, 0.2 mm pitch)	Dual-band WLAN + BT 4.0 + FM	-30°C to +85°C
BCM4330XKFFBG	144 ball FCFBGA (6.5 mm x 6.5 mm, 0.5 mm pitch)	Dual-band WLAN + BT 4.0 + FM	-30°C to +85°C

Not Recommended for New Designs

Broadcom® Corporation reserves the right to make changes without further notice to any products or data herein to improve reliability, function, or design.

Information furnished by Broadcom Corporation is believed to be accurate and reliable. However, Broadcom Corporation does not assume any liability arising out of the application or use of this information, nor the application or use of any product or circuit described herein, neither does it convey any license under its patent rights nor the rights of others.

Connecting
everything®



BROADCOM CORPORATION

5300 California Avenue

Irvine, CA 92617

© 2011 by BROADCOM CORPORATION. All rights reserved.

Phone: 949-926-5000

Fax: 949-926-5203

E-mail: info@broadcom.com

Web: www.broadcom.com

Looking for pricing, stock, or lifecycle information?

Click below to explore more details on WIN SOURCE:

 [View CYW4330XKUBGT on WIN SOURCE](#)

 [Infineon Technologies](#) Information

Optimize Your Supply Chain with WIN SOURCE Solutions

-  Global Sourcing Solution
-  Obsolete Management
-  Cost Control Management
-  Shortage Management
-  Alternative Solution
-  Excess Inventory Management