



**THE DATASHEET OF
UPM1H471MHD**



WFM200S Data Sheet

The Silicon Labs WFM200S is an Ultra Low Power Wi-Fi® transceiver or network co-processor (NCP) SiP module targeted for applications where optimal RF performance, low-power consumption, and secure end-to-end solution, together with fast time to market, are key requirements.

The very compact 6.5mm x 6.5mm WFM200S SiP module contains an embedded antenna, high frequency crystal, and shield. This all-inclusive module offer the fastest time to market.

The WFM200S integrates a balun, T/R switch, LNA and PA for the best possible RF performance. Co-existence with external 2.4GHz transceivers is supported via a PTA interface.

WFM200S has been optimized for resource and power constrained devices at the RF, protocol and firmware levels. Power conscious devices can take advantage of these features in both active and idle/sleep modes.

For security sensitive applications, the WFM200S provides secure boot and a secure, encrypted host interface. Robust security is made possible with the native integrated True Random Number Generator and OTP memory for confidential encryption key storage.

The WFM200S fits well with Linux-based and RTOS-based host processors. WFM200S supports both the 802.11 split MAC architecture and the 802.11 full MAC software architecture. WFM200S communicates with the external host controller over the SPI or SDIO interface.

KEY POINTS

- IEEE 802.11 b/g/n compliant
- Embedded high efficiency antenna
- Integrated crystal and shield
- 105°C ambient temp support
- TX power: up to +15.1 dBm
- RX sensitivity: -96.3 dBm
- Integrated switched antenna diversity support
- Ultra low power consumption
- Secure and signed software
- Encrypted host interface communication
- Linux and RTOS host support
- Certifications
 - CE (EU), UKCA (UK), FCC (USA), ISED (Canada), MIC (Japan), KC (South Korea)
- 6.5 x 6.5 mm SiP Module

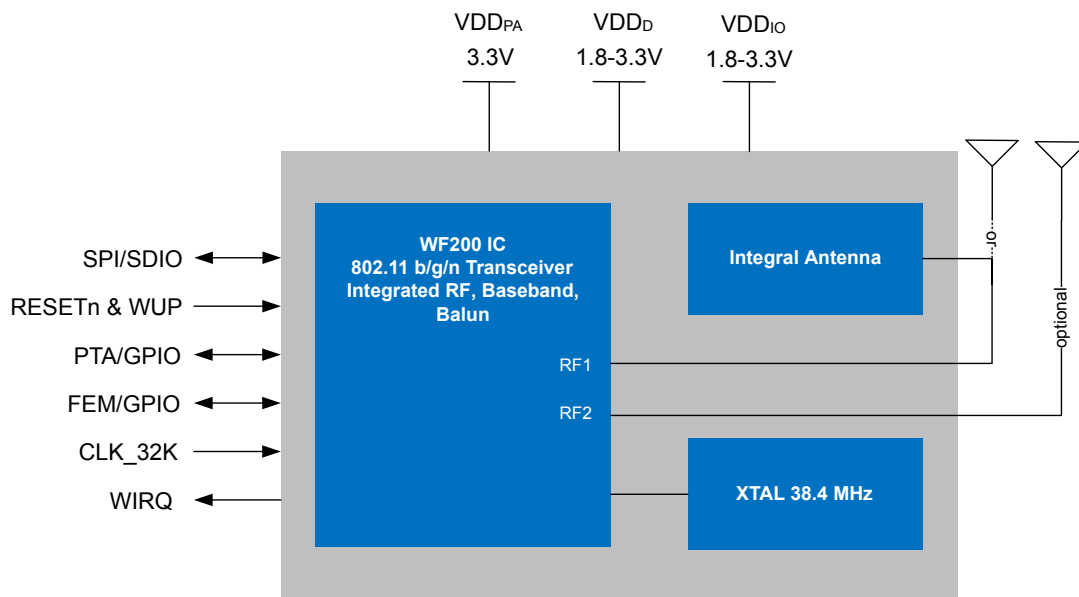

1. Features List

The WFM200S Wi-Fi SiP module key features are listed below.

Applications

- Industrial, Home and Building automation
- Home appliances
- Security solutions
- Retail and Commercial
- Commercial transportation
- Consumer medical
- Sports and Fitness

Features

- 802.11 b/g/n Wi-Fi NCP including the radio, baseband, MAC, security and host interface
- Integrated LNA, PA and Balun
- Integrated 38.4 MHz Crystal and embedded antenna
- OTP included removing the need for an external EEPROM
- Ultra low power optimized solution
- End-to-end security with hardware protected secure boot and encrypted host interface (optional)
- 802.11 split and full MAC architecture support
- Complete Network Co-Processor (NCP) support for Linux and RTOS external hosts

Standards/IEEE 802.11 and WFA

- b - symbol rates: up to 11 Mbps
- g - symbol rates: up to 54 Mbps
- n - symbol rates: up to 72.2Mbps
- d - regulatory domains
- e - QoS as per definition in WMM specification
- i - as per definition in WPA2 specification
- w - protected management frames
- WMM Power save
- WPA/WPA2 Personal/WPA3 Personal
- Supported with Linux UMAC:
 - WPA2 Enterprise
 - WPS - Wi-Fi Protected Setup

Key MAC and Baseband Features

- 1x1 802.11n (20 MHz) with full 802.11 b/g compatibility, 72.2Mbps
- Greenfield Tx/Rx for 802.11n optimal performance
- Short Guard Interval (SGI) for 802.11n optimal throughput
- A-MPDU Rx and Tx for high MAC throughput
- Block acknowledgement for several frames
- Rx Defragmentation
- Roaming supported
- Client, SoftAP modes supported
- Concurrent AP + STA supported on different channels

RF Features

- Tx Power: +15.1 dBm
- Rx Sensitivity: -96.3 dBm
- 2 x 2.4GHz antenna pads for switched antenna diversity support
- 2.4GHz co-existence; 2-, 3- and 4-wire PTA support
- Integrated Balun, T/R switch, LNA and PA for 2.4GHz

Power Consumption

- Rx (@DSSS-1Mbps): 42.3 mA
- Tx (15.1 dBm @DSSS-1Mbps): 145 mA
- Associated DTIM3 average current : 298 μ A
- Associated Sleep Current : 22 μ A
- Shutdown mode: 0.5 μ A

Security and Encryption Features

- Secure boot with roll-back prevention
- Encrypted host interface, dedicated hardware acceleration block (optional)
- Integrated True Random Number Generator
- Secure key storage using protected OTP technology
- AES/WEP hardware acceleration

Host Interfaces

- SDIO (1-bit and 4-bit SD mode @ 26MHz)
- SPI (1-bit @ 52MHz)

Peripheral Interfaces

- External 32kHz crystal for low power
- GPIOs (including wake-up and Tx/Rx activity monitoring)

ROHS/REACH Compliant

Certifications

- CE (EU), UKCA (UK), FCC (USA), ISED (Canada), MIC (Japan), KC (South Korea)

Electrical Characteristics

- 1.62V - 3.6V (VDD_D, VDD_{IO})
- 3.0 - 3.6V (VDD_{PA})

Packaging

- 6.5x6.5 LGA58 SiP Module
- Temperature range: -40°C to +105°C

2. Ordering Information

This section contains ordering information for WFM200S.

Note: The parts may be referred to by the product family friendly name (WFM200S), or by the model names (WFM200SA, WFM200SN), or by the full orderable part numbers throughout this document

Table 2.1. WFM200S Ordering Information (R indicates Full Reel)

Part Number	Description	Antenna Type	Package
WFM200S022XNA3(R)	WFM200S 802.11bgn NCP	Embedded	6.5x6.5 LGA52 SiP module
WFM200SS22XNA3(R)	WFM200S 802.11bgn NCP Secure host interface	Embedded	6.5x6.5 LGA52 SiP module
WFM200S022XNN3(R)	WFM200S 802.11bgn NCP	External only	6.5x6.5 LGA52 SiP module
WFM200SS22XNN3(R)	WFM200S 802.11bgn NCP Secure host interface	External only	6.5x6.5 LGA52 SiP module

Table of Contents

1. Features List	2
2. Ordering Information	3
3. System Overview	6
3.1 Introduction	6
3.2 Wi-Fi Supported 2.4 GHz Bandwidth and Channels	7
4. Electrical Specifications	8
4.1 Absolute Maximum Ratings	8
4.2 Operating Conditions	9
4.3 Power Consumption	10
4.4 RF Transmitter General Characteristics	11
4.4.1 RF Transmitter Characteristics	12
4.5 RF Receiver General Characteristics	12
4.5.1 RF Receiver Characteristics	13
4.6 Reference Oscillator and Low Power Clock Characteristics	14
4.6.1 Low Power 32.768 kHz Clock Input Requirements	14
4.7 Interface Terminal Characteristics	14
4.7.1 Supply Terminal Specifications	14
4.7.2 Digital I/O Terminal Specifications	15
4.8 Host Interface	15
4.8.1 SPI Specification	17
4.8.2 SDIO Specification	18
5. Typical Applications and Connections	19
5.1 Typical Application Circuit for SDIO Host Interface	19
5.2 Typical Application Circuit for SPI Host Interface	20
5.3 Power States and Low-Power Modes	21
5.4 RF Connections	21
5.4.1 RF Ports	21
5.4.2 Antenna Diversity	21
5.4.3 Embedded Antenna Pins	21
5.5 Clocks	21
5.5.1 High Frequency Crystal Oscillator	21
5.5.2 LP_CLK Port	22
5.6 Multi-Protocol Coexistence	22
6. Pin Descriptions	23
7. Package Outline	25
8. Land Pattern	29
9. Top Marking	31

10. Tape and Reel Specifications	32
10.1 Tape and Reel Packaging	.32
10.2 Reel and Tape Specifications	.32
10.3 Orientation and Tape Feed	.34
10.4 Tape and Reel Box Dimensions	.34
10.5 Moisture Sensitivity Level	.34
11. Software Reference	35
11.1 Host and Device Software	.35
11.1.1 Split MAC	.35
11.1.2 Full MAC	.36
11.1.3 Software Documentation	.36
11.2 Security	.36
11.2.1 Secure Device	.36
11.2.2 Secure Boot	.37
11.2.3 Secure Link (WFM200SS only)	.37
11.3 Startup, Sleep and Shutdown	.37
11.3.1 Power On, Reset, and Boot	.37
11.3.2 Sleep and Snooze Modes	.37
11.3.3 Shutdown Mode	.38
12. Certifications	39
12.1 Qualified External Antenna Types	.39
12.2 CE and UKCA - EU and UK	.39
12.3 FCC - USA	.40
12.4 ISED - Canada	.41
12.5 MIC - Japan	.43
12.6 KC - South Korea	.44
12.7 Locating the Module Close to Human Body	.44
13. Revision History	45

3. System Overview

3.1 Introduction

WFM200S is a WiFi network co-processor module optimized for RF performance, low energy, and low cost, with two antenna ports, Crystal Oscillator, One Time Programmable Memory, and several GPIOs for interfacing with multi-protocol and RF Front End Module controls.

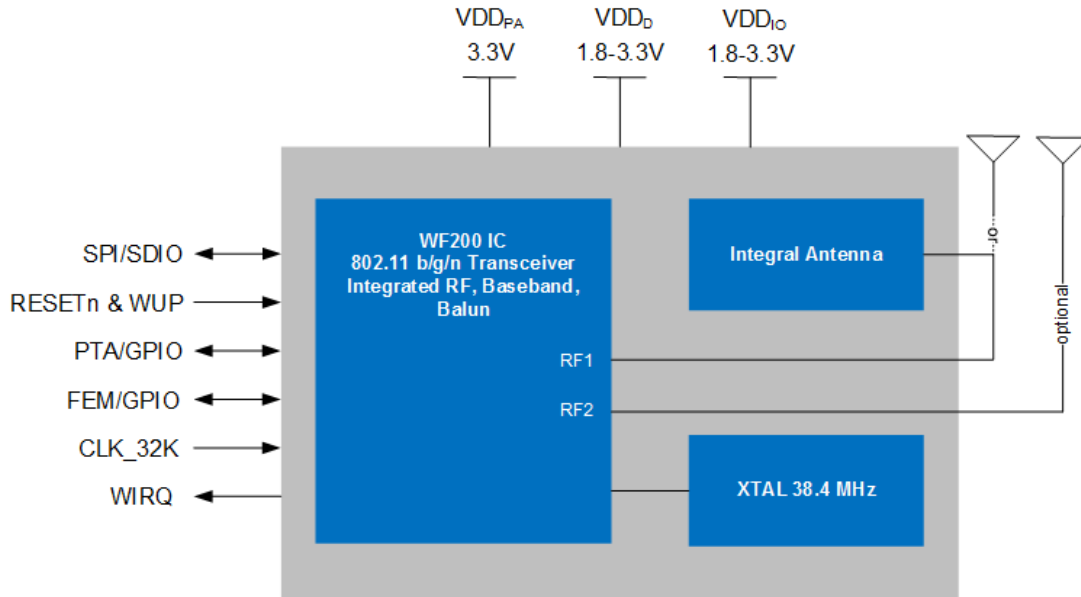

Figure 3.1. WFM200SA Block Diagram

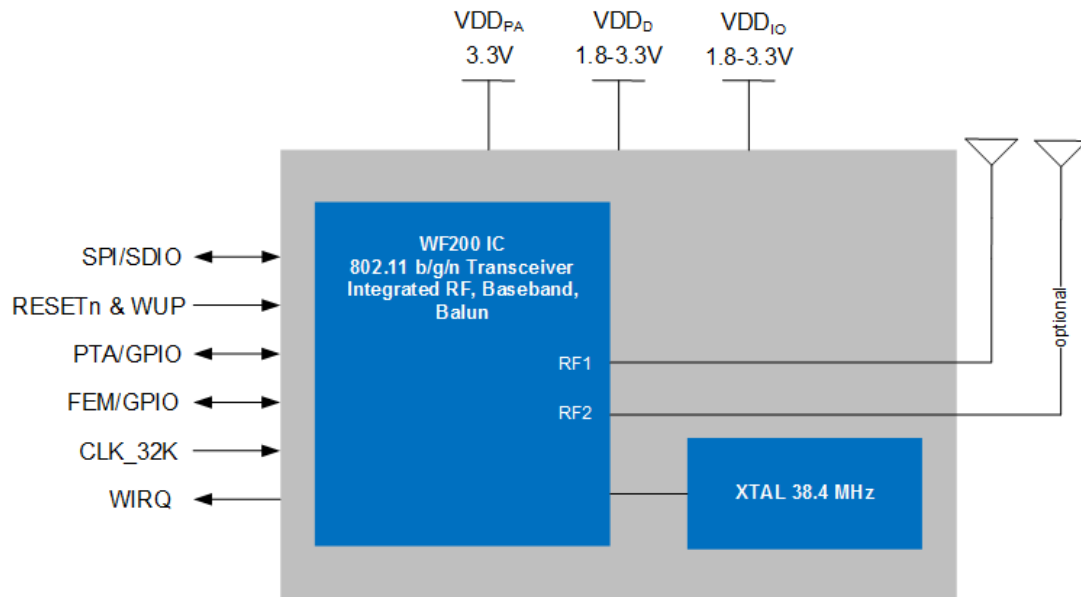

Figure 3.2. WFM200SN Block Diagram

3.2 Wi-Fi Supported 2.4 GHz Bandwidth and Channels

Supported operating frequencies and bandwidth

Table 3.1. Supported Wi-Fi Modulations, BW, and Channels

Parameter	Symbol	Test Condition	Min	Typ	Max	Unit
Channel Center Frequency	CHAN	Subject to Regulatory Agency	2412		2484	MHz
Channel Bandwidth	BW		—	20	—	MHz

Note:

1. Channel 14 (2484 MHz) is meant for operation in the Japan market, and it only supports 1 and 2 Mbps modulations.

4. Electrical Specifications

All electrical parameters in all tables are specified under the following conditions, unless stated otherwise:

- Typical values are based on $T_A = 25\text{ }^\circ\text{C}$; V_{VDD_IO} , V_{VDD} , $V_{VDD_PA} = 3.3\text{V}$
- Radio performance numbers are measured in conducted mode, based on Silicon Labs reference designs
- WFM200S features and benefits depend on system configuration and may require specific driver, firmware or service activation. Learn more at <https://www.silabs.com/products/wireless/wi-fi>

Refer to Section 4.2 [Operating Conditions](#) for more details about operational supply and temperature limits.

4.1 Absolute Maximum Ratings

Stresses above those listed below may cause permanent damage to the device. This is a stress rating only and functional operation of the devices at those or any other conditions above those indicated in the operation listings of this specification is not implied. Exposure to maximum rating conditions for extended periods may affect device reliability. For more information on the available quality and reliability data, see the Quality and Reliability Monitor Report at <http://www.silabs.com/support/quality/pages/default.aspx>.

Table 4.1. Absolute Maximum Ratings

Parameter	Symbol	Test Condition	Min	Typ	Max	Unit
Storage temperature	T_{STG}		-40	—	150	$^\circ\text{C}$
Junction temperature	T_{JMAX}		-40	—	125	$^\circ\text{C}$
RF power level at RF1 and RF2 ports	P_{RFMAX}		—	—	10	dBm
Supply voltage to VDD_PA, VDD_IO, VDD	V_{DDMAX}		-0.3	—	3.6	V
Voltage on all other pins (GPIO, Host interface, PTA, etc.)	V_{GMAX}		-0.3	—	$V_{DDIO} + 0.3\text{ V}$	V
Current into any GPIO pin	$I_{O_{MAX}}$		—	—	20	mA
Sum of current into all GPIO pins	$I_{O_{ALL_MAX}}$		—	—	150	mA
Range of load impedance at RF1 and RF2 pins during TX	$LOAD_{TX}$		—	—	10:1	VSWR

4.2 Operating Conditions

Table 4.2. Recommended Operating Conditions

Parameter	Symbol	Test Condition	Min	Typ	Max	Unit
Ambient operating temperature	T_A		-40	—	105	°C
Junction operating temperature	T_J		-40	—	125	°C
DC supply voltage to VDD_PA ¹	V_{VDD_PA}		3.0	3.3	3.6	V
Nominal supply voltage to VDD	V_{VDD}		1.62	1.8	3.6	V
Nominal supply voltage to VDD_IO	V_{VDD_IO}		1.62	1.8	3.6	V
Note: 1. V_{VDD_PA} must always be greater than or equal to V_{VDD} .						

4.3 Power Consumption

Unless otherwise indicated, $V_{VDD_PA} = 3.3\text{ V}$, $V_{VDD} = V_{VDD_IO} = 1.8\text{ V}$.

Table 4.3. Power Consumption

Parameter	Symbol	Test Condition	Min	Typ	Max	Unit
TX mode current	I_{TX}	802.11.b: 1 Mbps, from VDD_PA at 3.3 V	—	99.4	—	mA
		802.11.b: 11 Mbps, from VDD_PA at 3.3 V	—	95.6	—	mA
		802.11.g: 6 Mbps, from VDD_PA at 3.3 V	—	95.2	—	mA
		802.11.g: 54 Mbps, from VDD_PA at 3.3 V	—	92.6	—	mA
		802.11.n: MCS = 0, from VDD_PA at 3.3 V	—	94.9	—	mA
		802.11.n: MCS = 7, from VDD_PA at 3.3 V	—	92.3	—	mA
		802.11.b: 1 Mbps, from 1.8 V supplies (VDD, VDD_IO)	—	45.5	—	mA
		802.11.b: 11 Mbps, from 1.8 V supplies (VDD, VDD_IO)	—	45.4	—	mA
		802.11.g: 6 Mbps, from 1.8 V supplies (VDD, VDD_IO)	—	46.7	—	mA
		802.11.g: 54 Mbps, from 1.8 V supplies (VDD, VDD_IO)	—	47.4	—	mA
		802.11.n: MCS = 0, from 1.8 V supplies (VDD, VDD_IO)	—	46.7	—	mA
		802.11.n: MCS = 7, from 1.8 V supplies (VDD, VDD_IO)	—	47.4	—	mA
RX mode current	I_{RX}	802.11.b: 1 Mbps, from 1.8 V supplies (VDD, VDD_IO)	—	42.3	—	mA
		802.11.b: 11 Mbps, from 1.8 V supplies (VDD, VDD_IO)	—	43.0	—	mA
		802.11.g: 6 Mbps, from 1.8 V supplies (VDD, VDD_IO)	—	45.4	—	mA
		802.11.g: 54 Mbps, from 1.8 V supplies (VDD, VDD_IO)	—	47.8	—	mA
		802.11.n: MCS = 0, from 1.8 V supplies (VDD, VDD_IO)	—	45.2	—	mA
		802.11.n: MCS = 7, from 1.8 V supplies (VDD, VDD_IO)	—	48.3	—	mA
Sleep current on power supply pins ¹	I_{SLEEP}	VDD_PA pin, $V_{VDD_PA} = 3.3\text{ V}$	—	66	—	nA
		VDD pin, $V_{VDD} = 1.8\text{ V}$	—	18.7	—	μA
		VDD_IO pin, $V_{VDD_IO} = 3.3\text{ V}$	—	3.5	—	μA

Parameter	Symbol	Test Condition	Min	Typ	Max	Unit
Snooze current on power supply pins ²	I _{SNOOZE}	VDD_PA pin, V _{VDD_PA} = 3.3 V	—	66	—	nA
		VDD pin, V _{VDD} = 1.8 V	—	1146	—	μA
		VDD_IO pin, V _{VDD_IO} = 3.3 V	—	51	—	μA
Shutdown current on power supply pins ³	I _{SHUTDOWN}	VDD_PA pin, V _{VDD_PA} = 3.3 V	—	67	—	nA
		VDD pin, V _{VDD} = 1.8 V	—	83.8	—	nA
		VDD_IO pin, V _{VDD_IO} = 3.3 V	—	49	—	nA
Average current for DTIM=1 Interval Profile ⁴	I _{LP_DTIM1}	VDD_PA pin, V _{VDD_PA} = 3.3 V	—	154	—	nA
		VDD pin, V _{VDD} = 1.8 V	—	891	—	μA
		VDD_IO pin, V _{VDD_IO} = 3.3 V	—	3.7	—	μA
Average current for DTIM=3 Interval Profile ⁴	I _{LP_DTIM3}	VDD_PA pin, V _{VDD_PA} = 3.3 V	—	128	—	nA
		VDD pin, V _{VDD} = 1.8 V	—	294	—	μA
		VDD_IO pin, V _{VDD_IO} = 3.3 V	—	3.6	—	μA
Average current for DTIM=10 Interval Profile ⁴	I _{LP_DTIM10}	VDD_PA pin, V _{VDD_PA} = 3.3 V	—	118	—	nA
		VDD pin, V _{VDD} = 1.8 V	—	103	—	μA
		VDD_IO pin, V _{VDD_IO} = 3.3 V	—	3.7	—	μA

Note:

1. All memory is retained in sleep mode. WUP on timer and/or interrupt.
2. All memory is retained and Xtal oscillator is kept on if no 32 kHz clock is provided.
3. Requires complete start-up sequence to resume operation.
4. All DTIM currents assume a 1 ms beacon time duration with a beacon interval of 102.4ms from the AP.

4.4 RF Transmitter General Characteristics

Unless otherwise indicated, typical conditions are: Operating Ambient Temp = 25 °C, V_{VDD_IO} = V_{VDD} = 1.8 V; V_{VDD_PA} = 3.3V, center frequency = 2,442 MHz, and measured in 50 Ω test equipment attached at antenna port. The output power levels are backed off to ensure compliance into a 2:1 VSWR antenna at the worst phase angles. More details are in UG395: WFM200 Hardware Design User's Guide.

Measurements for this specification are made using the RF_1 port. See Section 5.4.1 RF Ports.

4.4.1 RF Transmitter Characteristics

Table 4.4. RF Transmitter Characteristics

Parameter	Symbol	Test Condition	Min	Typ	Max	Unit
RMS output power into 50-Ω load with compliance for antenna up to 2:1 VSWR	POUT _{MAX_RMS_HPPA}	802.11b: 1 Mbps	—	15.1	—	dBm
		802.11b: 11 Mbps	—	13.0	—	dBm
		802.11g: 6 Mbps	—	12.5	—	dBm
		802.11g: 54 Mbps	—	7.1	—	dBm
		802.11n: MCS=0	—	12.1	—	dBm
		802.11n: MCS=7	—	5.0	—	dBm
Second Harmonic Level for POUT _{MAX_PA} Setting	HD2 _{MAX}	802.11b: 1 Mbps	—	-47.9	—	dBm
		802.11b: 11 Mbps	—	-49.1	—	dBm
		802.11g: 6 Mbps	—	-50.2	—	dBm
		802.11g: 54 Mbps	—	-54.2	—	dBm
		802.11n: MCS=0	—	-50.4	—	dBm
		802.11n: MCS=7	—	-55.6	—	dBm
Carrier Suppression per 802.11-2012 for POUT _{MAX_PA} setting	C _{SUP}	802.11b: 1 Mbps	—	-45.8	—	dBr
		802.11b: 11 Mbps	—	-44.3	—	dBr
		802.11g: 6 Mbps	—	-36.9	—	dBr
		802.11g: 54 Mbps	—	-35.9	—	dBr
		802.11n: MCS=0	—	-39.6	—	dBr
		802.11n: MCS=7	—	-31.4	—	dBr
POUT variation from VDD _{PA} =3.0 V to 3.6 V	POUT _{MAX_VAR_V}	VDD _{PA} = 3.0 V to 3.6 V, Measured on single channel	—	1.6	—	dB
POUT variation across temperature	POUT _{MAX_VAR_T}	25C to 85C	—	0.9	—	dB

4.5 RF Receiver General Characteristics

Unless otherwise indicated, typical conditions are: Operating Ambient Temp = 25 °C, V_{VDD_IO} = V_{VDD} = 1.8 V; V_{VDD_PA} = 3.3V, center frequency = 2,442 MHz, and measured in 50 Ω test equipment attached at antenna port.

Measurements for this specification are made using the RF₁ port. See Section 5.4.1 RF Ports.

4.5.1 RF Receiver Characteristics

Table 4.5. RF Receiver Characteristics

Parameter	Symbol	Test Condition	Min	Typ	Max	Unit
RX Sensitivity for 8% FER (1024 Octet)	SENS _B	802.11b: 1 Mbps	—	-96.3	—	dBm
		802.11b: 11 Mbps	—	-88.0	—	dBm
RX Sensitivity for 10% PER (1024 Octet)	SENS _G	802.11g: 6 Mbps	—	-91.5	—	dBm
		802.11g: 54 Mbps	—	-74.6	—	dBm
RX Sensitivity for 10% PER (4096 Octet)	SENSE _N	802.11n: MCS=0	—	-91.0	—	dBm
		802.11n: MCS=7	—	-71.7	—	dBm
Adjacent Channel (± 30 MHz) Selectivity with desired signal at 6 dB above reference sensitivity for 8% FER (1024 Octet)	ACS _{WB}	802.11b: 1 Mbps	—	56.0	—	dBc
		802.11b: 11 Mbps	—	45.2	—	dBc
Adjacent Channel (± 25 MHz) Selectivity with desired signal at 3 dB above reference sensitivity for 10% PER (1024 Octet)	ACS _{WG}	802.11g: 6 Mbps	—	47.9	—	dBc
		802.11g: 54 Mbps	—	32.2	—	dBc
Adjacent Channel (± 25 MHz) Selectivity with desired signal at 3 dB above reference sensitivity for 10% FER (4096 Octet)	ACS _{WN}	802.11n: MCS=0	—	47.5	—	dBc
		802.11n: MCS=7	—	29.9	—	dBc
2nd Adjacent Channel Selectivity (± 50 MHz) with desired at 6 dB above reference sensitivity 8% FER (1024 Octet)	A2CS _{WB}	802.11b: 1 Mbps	—	57.5	—	dBc
		802.11b: 11 Mbps	—	52.0	—	dBc
2nd Adjacent Channel Selectivity (± 50 MHz) with desired at 3 dB above reference sensitivity 10% PER (1024 Octet)	A2CS _{WG}	802.11g: 6 Mbps	—	52.4	—	dBc
		802.11g: 54 Mbps	—	36.4	—	dBc
2nd Adjacent Channel Selectivity (± 50 MHz) with desired at 3 dB above reference sensitivity 10% PER (4096Octet)	A2CS _{WN}	802.11n: MCS=0	—	51.7	—	dBc
		802.11n: MCS=7	—	33.4	—	dBc
RX Max Strong Signal for 8% FER (1024 Octet)	RX _{SAT_B}	802.11b: 1 Mbps	—	-4.0	—	dBm
		802.11b: 11 Mbps	—	-10.0	—	dBm
RX Max Strong Signal for 10% PER (1024 Octet)	RX _{SAT_G}	802.11g: 6 Mbps	—	-9.0	—	dBm
		802.11g: 54 Mbps	—	-9.0	—	dBm
RX Max Strong Signal for 10% PER (4096 Octet)	RX _{SAT_N}	802.11n: MCS=0	—	-9.0	—	dBm
		802.11n: MCS=7	—	-9.0	—	dBm

Parameter	Symbol	Test Condition	Min	Typ	Max	Unit
RX Channel Power Indicator Accuracy worst case with input swept from -60 dBm to RX_SAT	RCPI _{TOLS}	802.11b: 1 Mbps	—	-4.5	—	dB
		802.11g: 6 Mbps	—	-2.8	—	dB
		802.11n: MCS=7	—	-3.3	—	dB
RX Channel Power Indicator Accuracy Worst Case with input signal swept from reference sensitivity to -69 dbm	RCPI _{TOLW}	802.11b: 1 Mbps	—	-1.3	—	dB
		802.11g: 6 Mbps	—	-1.4	—	dB
		802.11n: MCS=7	—	-1.0	—	dB
RX Channel power Indicator Step Size	RCPI _{STEP}	802.11b: 1 Mbps	—	0.5	—	dB
		802.11g: 6 Mbps	—	0.5	—	dB
		802.11n: MCS=7	—	0.5	—	dB

4.6 Reference Oscillator and Low Power Clock Characteristics

The WFM200S contains a built-in 38.4 MHz XTAL to generate the reference clock.

To achieve low power operation during power save modes, an external 32.768 KHz clock is required.

4.6.1 Low Power 32.768 kHz Clock Input Requirements

Table 4.6. Low Power 32.768 kHz Clock Input Requirements

Parameter	Symbol	Test Condition	Min	Typ	Max	Unit
Nominal Frequency of LP_CLK	FNOM _{LPCLK}		—	32.768	—	KHz
Frequency Tolerance of LP_CLK over all conditions ¹	FTOL _{LPCLK}		-1000	—	1000	ppm
Load of LP_CLK pin	R _{LPCLK}		—	30	—	KOhm
Input Level at LP_CLK	SIGL _{LPCLK}		0.7 * VDD_IO	—	VDD_IO	V p-p
Symmetry of LP_CLK	DUTY _{LPCLK}		—	50	—	%

Note:

1. To optimize power consumption in DTIM modes, it is recommended that the frequency drift of LP_CLK within 1 second be lower than +/- 100ppm.

4.7 Interface Terminal Characteristics

Unless otherwise indicated, typical conditions are: Operating Ambient Temp = 25 °C, V_{VDD_IO} = V_{VDD} = 1.8 V; V_{VDD_PA} = 3.3V, center frequency = 2,442 MHz, and measured by 50 Ω test equipment attached at pin.

4.7.1 Supply Terminal Specifications

There are three supply pins to attach to DC power sources: VDD_PA, VDD and VDD_IO.

Please refer to the section on [4.2 Operating Conditions](#) for details on allowed voltages on these pins.

4.7.2 Digital I/O Terminal Specifications

Table 4.7. Digital I/O Terminal Specifications

Parameter	Symbol	Test Condition	Min	Typ	Max	Unit
Voltage input low (relative to V_{VDD_IO})	V_{IL}		—	—	30	%
Voltage input high (relative to V_{VDD_IO})	V_{IH}		70	—	—	%
Logic low output voltage (relative to V_{VDD_IO})	V_{OL}	Sinking 5 mA, $V_{VDD_IO} \geq 1.62$ V	—	—	25	%
Logic high output voltage (relative to V_{VDD_IO})	V_{OH}	Sourcing 5 mA, $V_{VDD_IO} \geq 1.62$ V	80	—	—	%
Input leakage current	I_{Leak}		—	1	—	nA
Pullup resistance	R_{PU}		30	43	65	k Ω
Pulldown resistance ¹	R_{PD}		30	43	65	k Ω
Output fall time from V_{OH} to V_{OL}	T_{OF}	50 pF load, $V_{VDD_IO} = 1.62$ V	—	15	—	ns
Output rise time from V_{OL} to V_{OH}	T_{OR}	50 pF load, $V_{VDD_IO} = 1.62$ V	—	15	—	ns
Note:						
1. RESETn pin has only pull-up resistance.						

4.8 Host Interface

The host interface allows control of WFM200S by an MCU or SoC using either SPI or SDIO. Selection between SPI and SDIO is done upon the logic state on SDIO_DAT2/HIF_SEL pin during the rising edge of RESETn signal. If this signal is HIGH, the host interface is configured as SDIO, otherwise it is configured as SPI. The tables below summarize the pin configurations for the two modes and the achievable speeds on both interfaces

Table 4.8. WFM200S SPI and SDIO interface pin configuration

WFM200S Pin Name	SPI Mode		SDIO Mode	
	0 -> 1	1	0 -> 1	1
RESETn	0 -> 1	1	0 -> 1	1
SDIO_DAT2/HIF_SEL	0	x	1	SDIO_DAT2
SDIO_CLK/SPI_CLK	x	SPI_CLK	x	SDIO_CLK
SDIO_CMD/SPI_MOSI	x	SPI_MOSI	x	SDIO_CMD
SDIO_DAT0/SPI_MISO	x	SPI_MISO	x	SDIO_DAT0
SDIO_DAT1/SPI_WIRQ	x	WIRQ (interrupt request to the SPI host)	x	SDIO_DAT1
SDIO_DAT3/SPI_CS _n	x	SPI_CS _n	x	SDIO_DAT3

Table 4.9. Host Interface Speeds

Parameter	Symbol	Test Condition	Min	Typ	Max	Unit
SDIO V2.0 clock rate	SD _{Rate}	Host Interface SDIO DS Mode	—	—	26	MHz
		Host Interface SDIO HS Mode	—	—	52	MHz
SPI clock rate	SPI _{Rate}	Host Interface SPI	—	—	52	MHz

Besides the main host interface signals, a couple of other pins also complement the host interface. See AN1219 for more details:

- The GPIO/WUP pin should be used by the host to wake up the WFM200S when in power-save mode. This pin is programmable and if power save is not enabled on the device, this pin can be configured as a GPIO. Note that this pin should be LOW to enable the WFM200S to reach sleep or shutdown modes.
- GPIO/WIRQ can also optionally be used as a duplication of the IRQ signal from SPI or SDIO. If this is not required, the pin can be configured as a GPIO.

4.8.1 SPI Specification

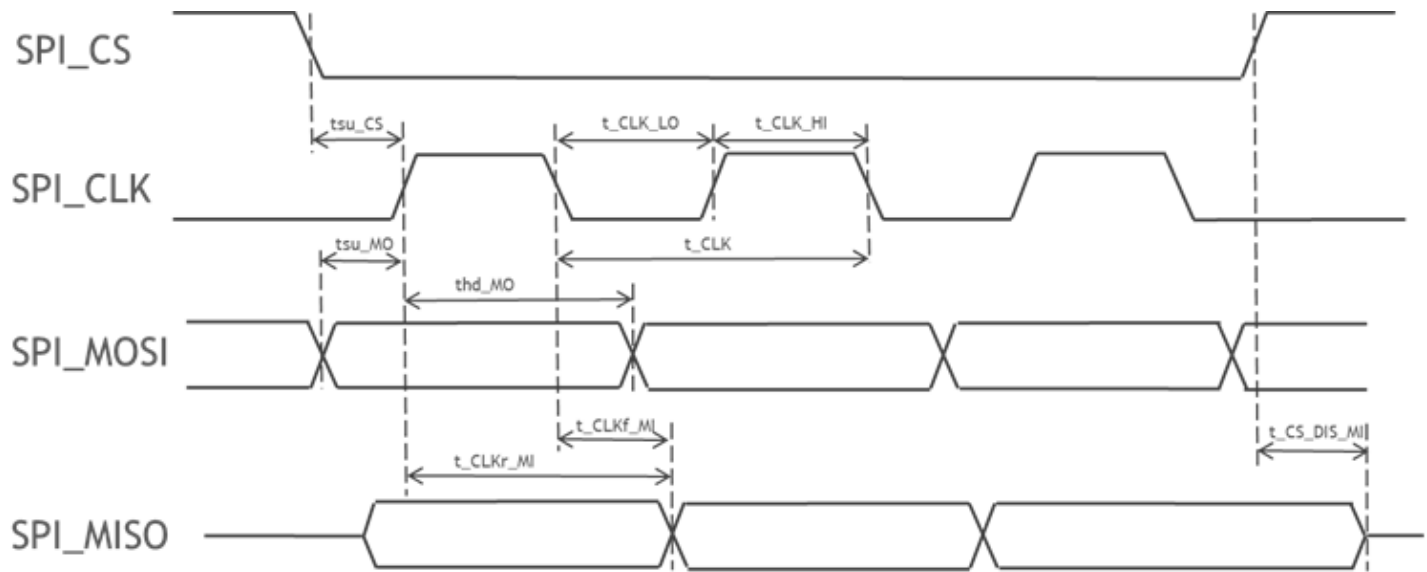

Figure 4.1. SPI Interface Timing Parameters

Table 4.10. SPI Interface Timing Specifications

Symbol	Description	Min.	Typ.	Max.	Unit
t_{CLK}	Clock period	19.23 ¹			ns
t_{CLK_HI}	Clock high	9			ns
t_{CLK_LO}	Clock low	9			ns
$t_{CS_DIS_MI}$	CS disable to MISO. $V_{DDIO} = 3.3V$			8	ns
	CS disable to MISO. $V_{DDIO} = 1.8V$			10	ns
t_{SU_CS}	CS setup time	3			ns
t_{SU_MO}	MOSI setup time	3			ns
t_{HD_MO}	MOSI hold time	3			ns
t_{CLKr_MI}, t_{CLKf_MI}	CLK to MISO out; $V_{DDIO} = 3.3V$			10	ns
	CLK to MISO out; $V_{DDIO} = 1.8V$			21	ns

Note:

1. 19.23 ns = 1/52 MHz
2. MISO can optionally be latched either on rising edge or falling edge of CLK
3. All timing parameters valid for output load up to 2 mA

4.8.2 SDIO Specification

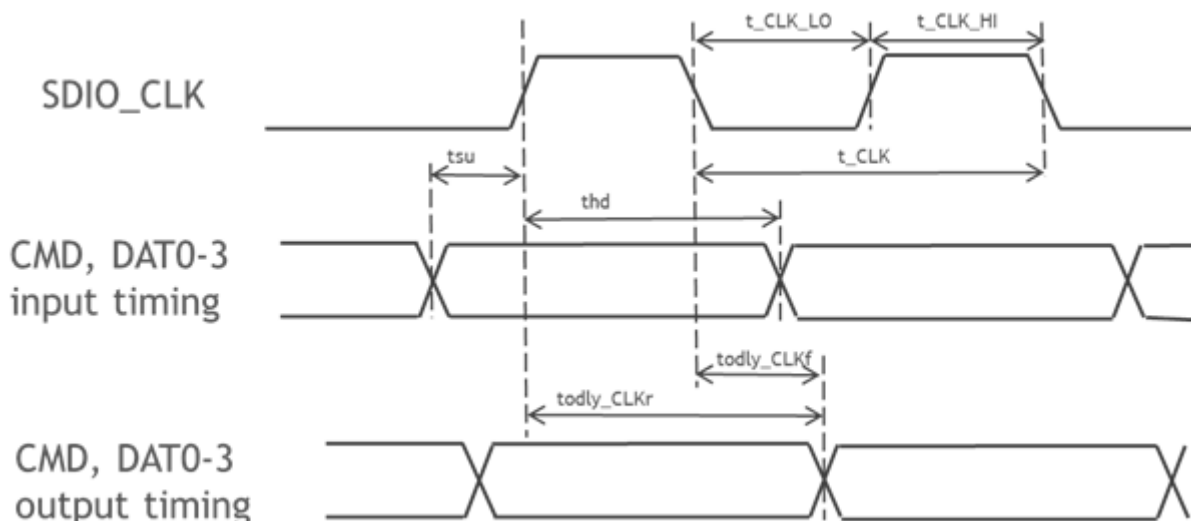

Figure 4.2. SDIO Interface Timing Parameters

Table 4.11. SDIO Interface Timing Specifications

Symbol	Description	Min	Typ	Max	Unit	Conditions
t_{CLK_HS}	Clock period in high speed mode	19.23			ns	$CL \leq 20pF$
t_{CLK_DS}	Clock period in default speed mode	38.46			ns	$CL \leq 20pF$
t_{CLK_LO}	Clock low time	9			ns	$CL \leq 20pF$
t_{CLK_HI}	Clock high time	9			ns	$CL \leq 20pF$
CMD, DAT0~3 Inputs (with reference to SDIO_CLK)						
t_{SU}	Input Set time	3			ns	$CL \leq 20pF$
t_{HD}	Input Hold time	3			ns	$CL \leq 20pF$
CMD, DAT0~3 Outputs (with reference to SDIO_CLK)						
t_{ODLY_CLKr} , t_{ODLY_CLKf}	Output delay time (relative to rising and falling edge) for $VDD = 3.3V$			11	ns	$VDD_{IO} = 3.3V$; $CL \leq 20pF$
	Output delay time (relative to rising and falling edge) for $VDD = 1.8V$			22	ns	$VDD_{IO} = 1.8V$; $CL \leq 20pF$
t_{OH}	Output Hold time	3			ns	$CL \leq 20pF$
1. Output data can be latched either on rising edge (HS mode) or falling edge (DS mode) of CLK 2. All timing parameters valid for output load of up to 2 mA						

5. Typical Applications and Connections

5.1 Typical Application Circuit for SDIO Host Interface

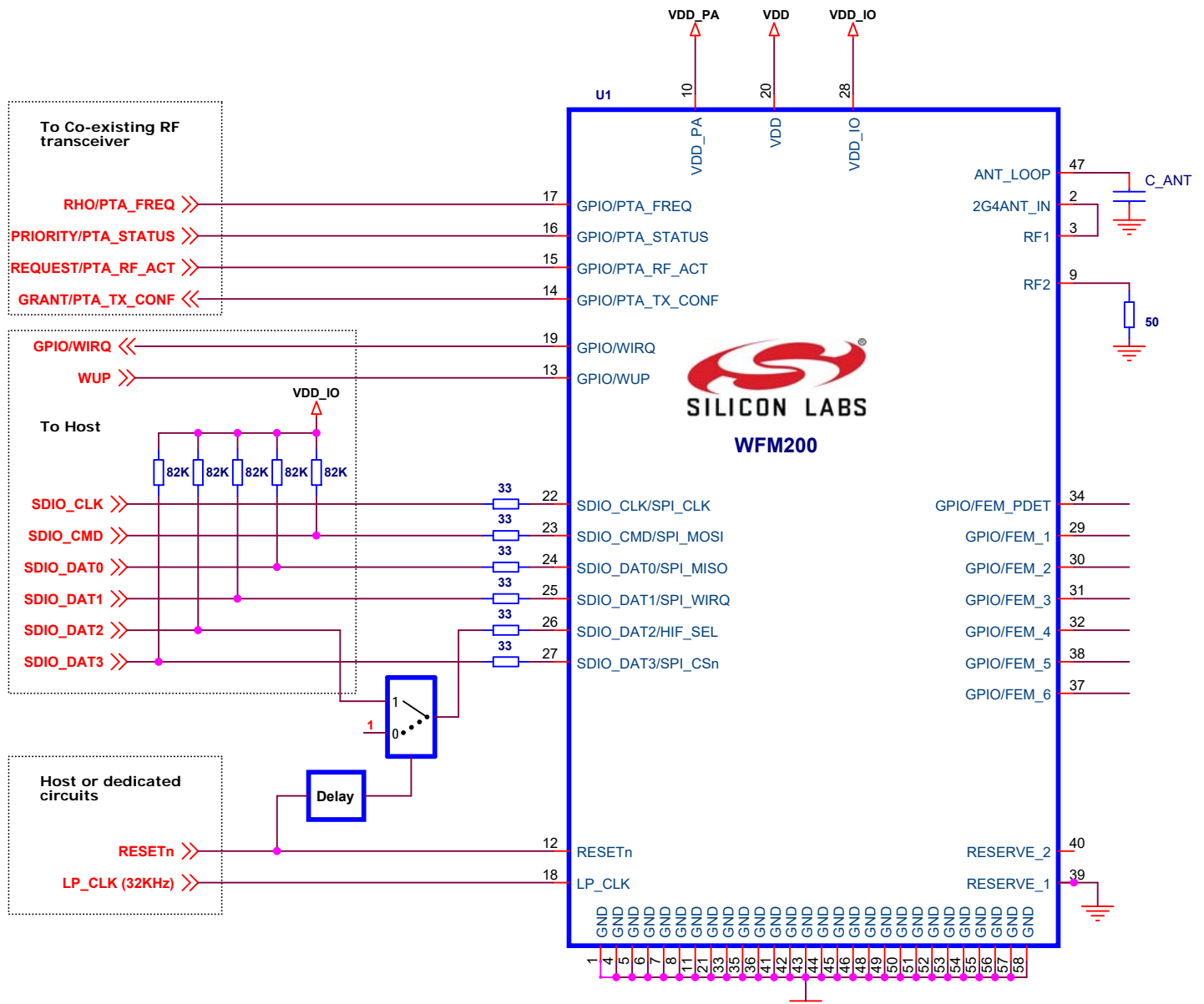

Figure 5.1. Typical Application Circuit SDIO Host Interface

- Note:**
- The SDIO pin pullup resistors are only required if the Host does not integrate internal pull-ups on SDIO signals as required by the SDIO standard.
 - Refer to UG395: WFM200S Hardware Design User's Guide for more details on the application circuit.

5.2 Typical Application Circuit for SPI Host Interface

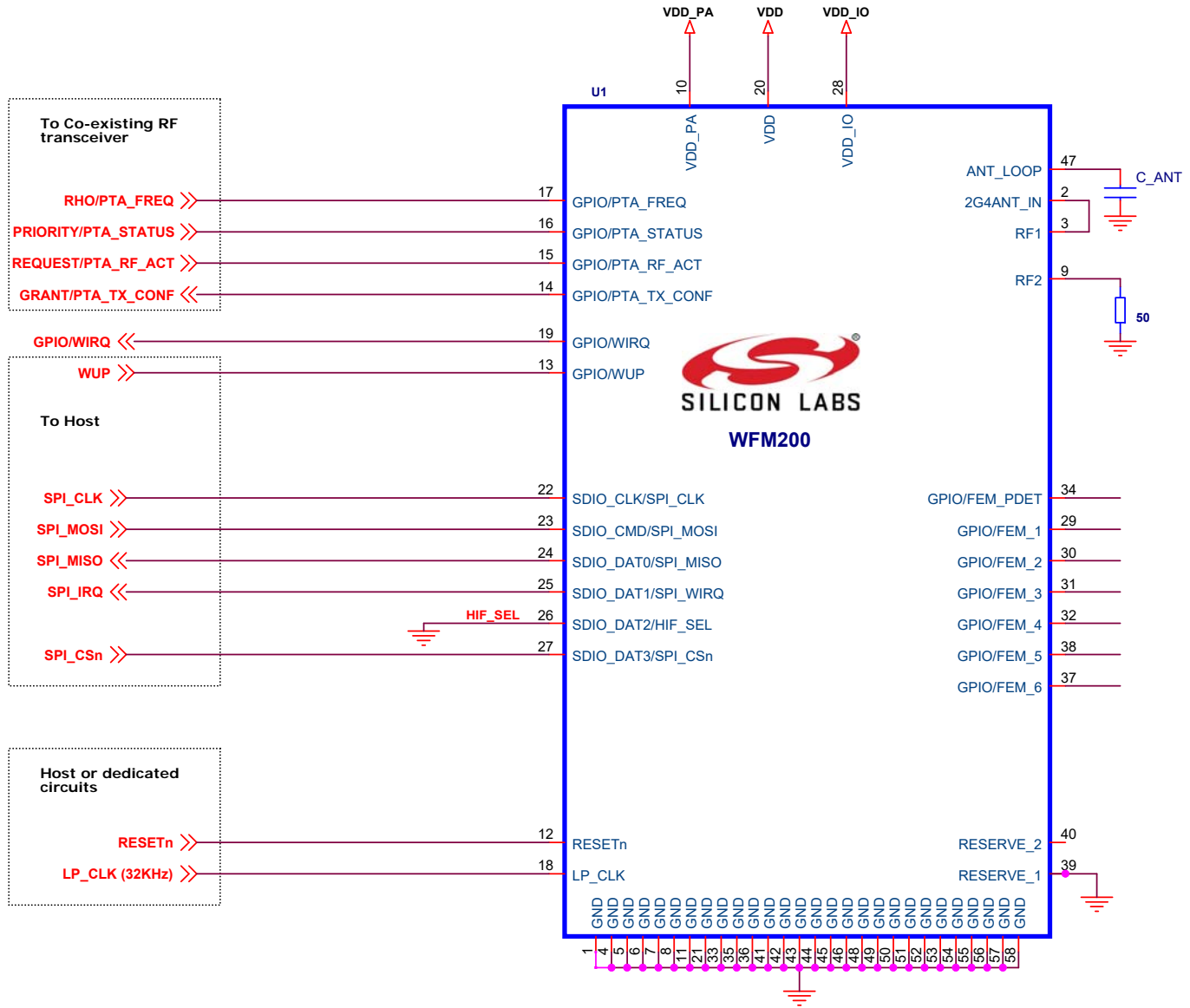

Figure 5.2. Typical Application Circuit SPI Host Interface

Note:

- Refer to UG395: WFM200S Hardware Design User's Guide for more details on the application circuit.

5.3 Power States and Low-Power Modes

The current consumption on WFM200S is highly dynamic. It varies significantly depending on its activity, the activation of power-save modes, and when it is in shutdown.

There are four main modes, each of them having several power states as detailed below.

Traffic mode: The Traffic mode is defined as the mode when WFM200S is transmitting data, receiving data, or listening to the channel. If power save is not activated, the device stays in listen mode when there is no traffic. Current consumption is similar between receive and listen modes, while it is higher during transmission.

Power save modes: When power save mode is activated, the device goes to a low-consumption mode and wakes-up periodically to listen to network beacons, so the device stays associated to the network. The current consumption, while receiving beacons, is as mentioned above for reception.

There are three power-save/low-power consumption cases:

1. **Sleep:** If a 32 KHz clock is available at LP_CLK input, then the device goes in sleep mode between reception of beacons. In this mode, most of the chip is turned off (including Xtal oscillator and host interface) to reduce the power consumption as much as possible. Given that the host interface is shut down in this mode, the host should assert the WUP pin to wake up the device before any communication with the host can be achieved.
2. **Sleep with XO on:** If low-power clock is not available on LP_CLK or if the Xtal oscillator cannot be shut down, then the device goes in "Sleep with XO on" mode between reception of beacons. In this mode, the Xtal oscillator is active, so the typical consumption is higher.
3. **Snooze:** If low-power clock is not available on LP_CLK then the device goes in snooze mode between reception of beacons. In this mode, a smaller part of the device is shut down and the XO is always enabled, so the typical consumption is higher.

The sleep or snooze state/mode can also be achieved when not associated if the firmware decides there are no tasks to perform when the wake-up signal (pin GPIO/WUP) from host is low.

Shutdown mode: Shutdown mode is the case where the transceiver is shut down and reaches the lowest power consumption while still being connected to the power supplies. Getting out of stand-by requires a complete start-up sequence triggered by RESETn pin being set from low to high.

Reset mode: When RESETn is low, the consumption is typically 76 μ A, mainly due to the RESETn pull-up resistor within the device.

5.4 RF Connections

5.4.1 RF Ports

This device has two RF ports to allow antenna diversity using an internal switch. In applications with only one antenna, the un-used port should be terminated to ground through a resistor between 47 to 51 Ω .

5.4.2 Antenna Diversity

In Applications where the main antenna is subject to obstruction or de-tuning, a second antenna can be attached to the alternate RF port by using the diversity antenna switch. The location of this second antenna should be such that both cannot be prevented from operating satisfactorily by the same event. A firmware feature can be invoked to determine which antenna has a better path to the remote Wi-Fi Device.

5.4.3 Embedded Antenna Pins

For OPNs with embedded antenna, pin 2 (2G4ANT_IN) is the antenna input port. This has a reference impedance of 50 Ohms on nominal size host boards. The pin 3 (RF_1 port) is coupled to pin 2 when using the embedded antenna. Pin 47 is an intermediate connection to a loop trace on the host board. Follow UG395 for required dimensions of this trace when using the embedded antenna. When not using the embedded antenna, pin 2 and pin 47 are left floating. For OPNs without embedded antenna, pin 2 and pin 47 are disconnected internally.

5.5 Clocks

5.5.1 High Frequency Crystal Oscillator

WFM200S has an internal 38.4MHz crystal used with the integrated oscillator circuitry to provide High Frequency Crystal Oscillator as the internal reference clock. A proprietary technique is used to calibrate and compensate for frequency errors. This achieves a frequency stability of +/-20ppm over the operating temperature range.

5.5.2 LP_CLK Port

A 32.768KHz clock source should be supplied to LP_CLK pin to enable the lowest power operation in power save modes. The frequency tolerance of this source affects wake up scheduling.

5.6 Multi-Protocol Coexistence

In case an RF transceiver using the same 2.4 GHz band (e.g. Bluetooth, Zigbee, or Thread) is co-located with the WFM200S Wi-Fi transceiver, the Packet Traffic Arbitration (PTA) interface can be used to minimize mutual interference. In this case, PTA pins are connected to the other transceiver. The PTA interface is highly programmable and can use 1, 2, 3, or 4 pins upon configuration. WFM200S embeds a Packet Traffic Arbitration block in order to share the access to the RF medium between WLAN and another standard.

Depending on manufacturer, PTA signal names can vary and the table below shows some alternative naming:

Table 5.1. PTA Alternative Naming

WFM200S Pin Name	Alternative Names
PTA_TX_CONF	GRANT, WL_ACTIVE, WL_DENY
PTA_RF_ACT	REQUEST, BT_ACTIVE
PTA_STATUS	PRIORITY, BT_STATUS
PTA_FREQ	FREQ, BT_FREQ

PTA interface configuration is also achieved via the configuration file.

See <https://docs.silabs.com/wifi/wf200/additional-resources#documentation> for more information regarding PTA and coexistence management on WFM200S, as well as AN1128 for EFR32BGx and EFR32MGx devices supporting BLE, Zigbee, and Thread.

6. Pin Descriptions

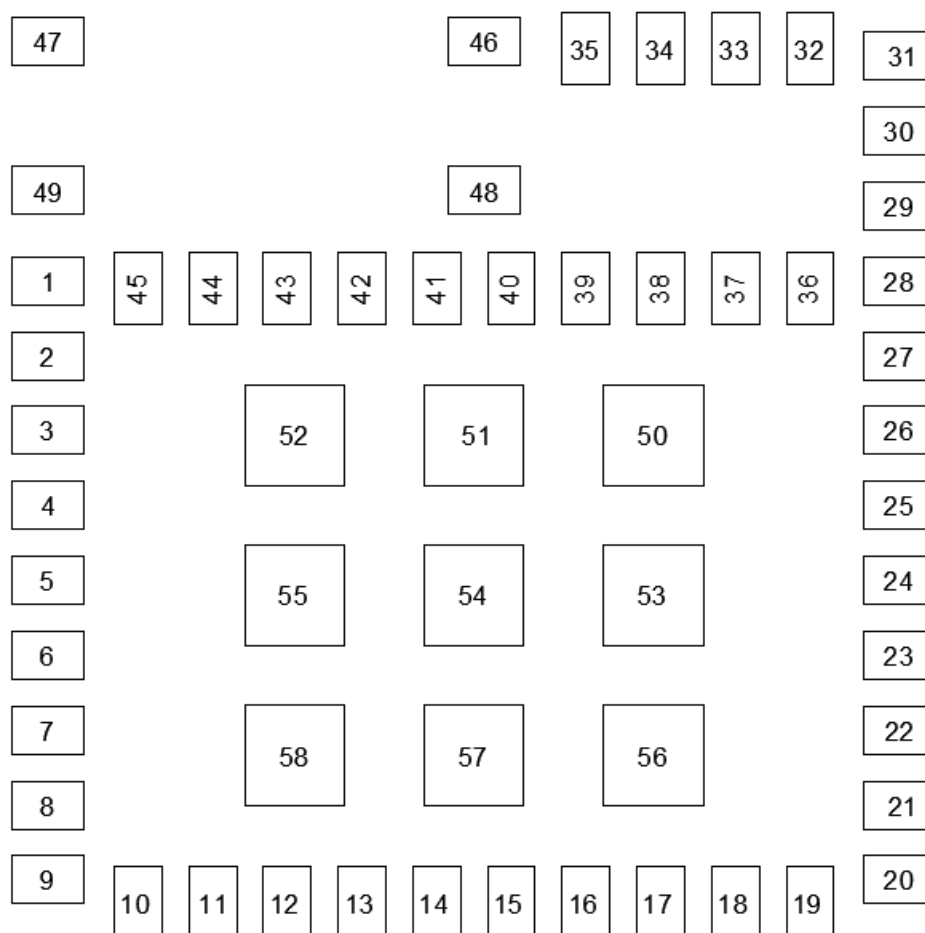

Figure 6.1. WFM200S Pinout

Table 6.1. Pin Definitions

Pin #	Pin Name	Pin Type	Description / Default
1	GND	GND	
2	2G4ANT_IN	Analog	Embedded 2.4 Ghz antenna Port. To use the embedded antenna, this pin should be connected to RF_1. For OPNs without an embedded antenna, the pin is a No Connect
3	RF_1	Analog	RF_1 port + matching. Can be connected to 2G4ANT_IN pin. If this pin is not used, it should be connected to GND through a 50 Ω resistor.
4-8	GND	GND	
9	RF_2	Analog	RF_2 port + matching. Can be connected to a second antenna for switched antenna diversity. If this pin is not used, it should be connected to GND through a 50 Ω resistor.
10	VDD_PA	VDD	Power supply for the power amplifier
11	GND	GND	

Pin #	Pin Name	Pin Type	Description / Default
12	RESETn	Input	Reset pin, active low
13	GPIO/WUP	I/O	This pin should be used to wake-up the chip while in power-save mode using LP_CLK. If not used, the pin can be used as a GPIO
14	GPIO/PTA_TX_CONF	I/O	As part of PTA interface, these pins can be used to manage co-existence with another 2.4 GHz radio, or can be used as GPIO
15	GPIO/PTA_RF_ACT	I/O	
16	GPIO/PTA_STATUS	I/O	
17	GPIO/PTA_FREQ	I/O	
18	LP_CLK	Input	Low Power clock input. This pin is typically connected to the 32 KHz clock. If not used, the pin should be connected to GND
19	GPIO/WIRQ	I/O	This pin can be used as an IRQ to host for SDIO, or can be used as a GPIO.
20	VDD	VDD	Power supply for the digital and RF parts
21	GND	GND	
22	SDIO_CLK/SPI_CLK	Input	Host interface: SDIO_CLK or SPI_CLK
23	SDIO_CMD/SPI_MOSI	I/O	Host interface: SDIO_CMD or SPI_MOSI
24	SDIO_DAT0/SPI_MISO	I/O	Host interface: SDIO_DAT0 or SPI_MISO
25	SDIO_DAT1/SPI_WIRQ	I/O	Host interface: SDIO_DAT1 or WIRQ
26	SDIO_DAT2/HIF_SEL	I/O	Host interface selection: Used to select the host interface during RESETn rising edge. If Low, selects SPI interface. When High, selects SDIO interface and this pin becomes SDIO_DAT2
27	SDIO_DAT3/SPI_CS _n	I/O	Host interface: SDIO_DAT3 or SPI_CS _n
28	VDD_IO	VDD	Power supply for I/Os
29	GPIO	I/O	These pins can be used for GPIO.
30	GPIO	I/O	
31	GPIO	I/O	
32	GPIO	I/O	This pin can be used for dynamic control of an external Power Amplifier, otherwise this can be used as GPIO.
33	GND	GND	
34	GPIO	I/O or Analog	This pin can be used as a GPIO
35,36	GND	GND	
37	GPIO	I/O	These pins can be used for GPIO.
38	GPIO	I/O	
39	RESERVE_1	N/A	Reserved. For normal operation, this pin must be grounded.
40	RESERVE_2	N/A	Reserved. This pin should be left unconnected.
41-46	GND	GND	
47	ANT_LOOP	Analog	To use the embedded antenna, this pin should be connected to ground through the embedded antenna loop capacitor. For OPNs without the embedded antenna, this pin should be a No Connect.
48-58	GND	GND	

7. Package Outline

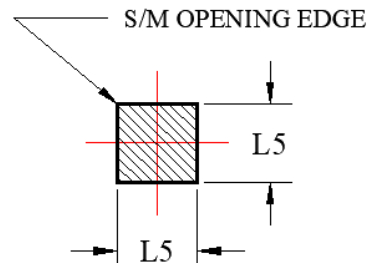
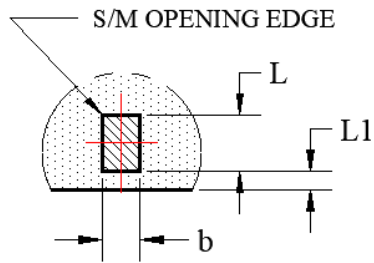
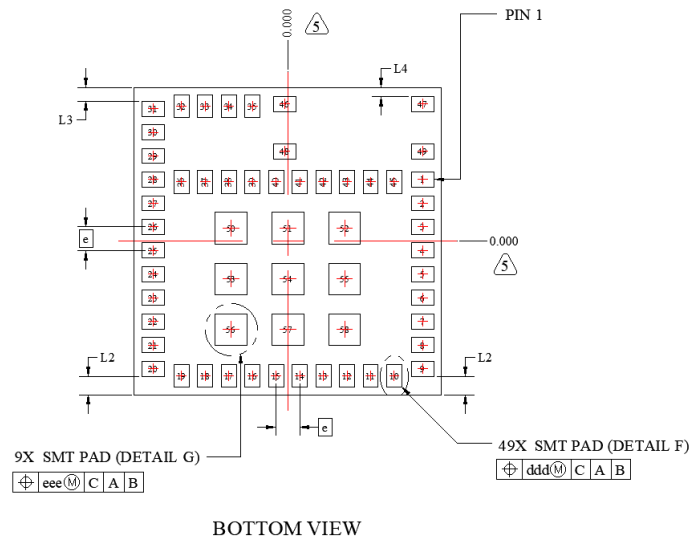
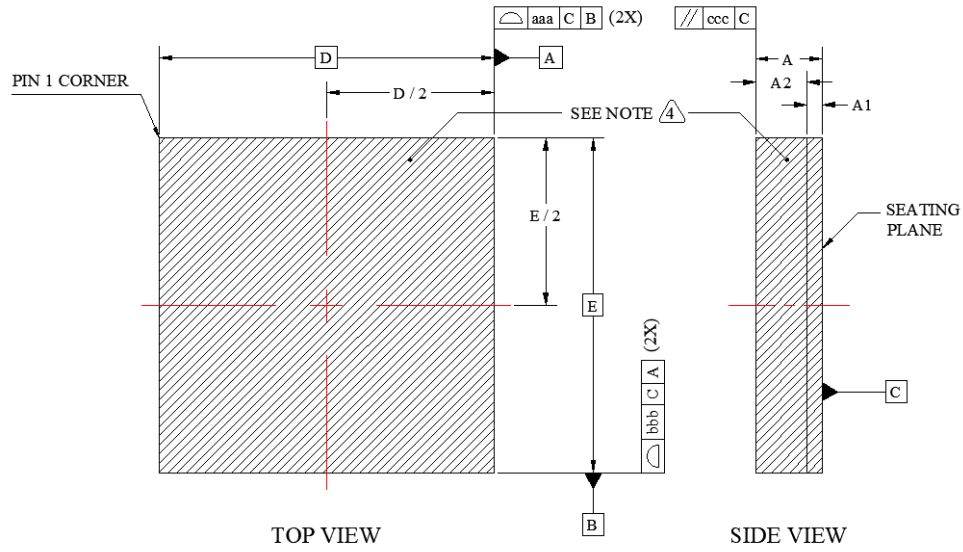

Figure 7.1. WFM200S Package Outline

Table 7.1. Package Outline Dimensions (in mm)

Dimension	MIN	NORM	MAX
A	1.20	1.30	1.40
A1	0.26	0.30	0.34
A2	0.95	1.00	1.05
b	0.27	0.32	0.37
D	6.50 BSC		
e	0.50 BSC		
E	6.50 BSC		
L	0.43	0.48	0.53
L1	0.11	0.16	0.21
L2	0.34	0.39	0.44
L3	0.24	0.29	0.34
L4	0.14	0.19	0.24
L5	0.62	0.67	0.72

Dimensions	MIN	MAX	NORM
aaa	0.10		
bbb	0.10		
ccc	0.10		
ddd	0.10		
eee	0.10		

Pad Number	Pad Coord (X,Y)		Pad Size (X,Y)		Pad Number	Pad Coord (X,Y)		Pad Size (X,Y)	
Note: These coordinates correspond to the BOTTOM view. Please refer to UG395: WFM200S Hardware Design User's Guide for the stencil design.									
1	2.850	1.300	0.480	0.320	30	-2.850	2.300	0.480	0.320
2	2.850	0.800	0.480	0.320	31	-2.850	2.800	0.480	0.320
3	2.850	0.300	0.480	0.320	32	-2.250	2.850	0.320	0.480
4	2.850	-0.200	0.480	0.320	33	-1.750	2.850	0.320	0.480
5	2.850	-0.700	0.480	0.320	34	-1.250	2.850	0.320	0.480
6	2.850	-1.200	0.480	0.320	35	-0.750	2.850	0.320	0.480
7	2.850	-1.700	0.480	0.320	36	-2.250	1.250	0.320	0.480
8	2.850	-2.200	0.480	0.320	37	-1.750	1.250	0.320	0.480
9	2.850	-2.700	0.480	0.320	38	-1.250	1.250	0.320	0.480
10	2.250	-2.850	0.320	0.480	39	-0.750	1.250	0.320	0.480
11	1.750	-2.850	0.320	0.480	40	-0.250	1.250	0.320	0.480
12	1.250	-2.850	0.320	0.480	41	0.250	1.250	0.320	0.480
13	0.750	-2.850	0.320	0.480	42	0.750	1.250	0.320	0.480
14	0.250	-2.850	0.320	0.480	43	1.250	1.250	0.320	0.480
15	-0.250	-2.850	0.320	0.480	44	1.750	1.250	0.320	0.480
16	-0.750	-2.850	0.320	0.480	45	2.250	1.250	0.320	0.480
17	-1.250	-2.850	0.320	0.480	46	-0.070	2.900	0.480	0.320
18	-1.750	-2.850	0.320	0.480	47	2.850	2.900	0.480	0.320
19	-2.250	-2.850	0.320	0.480	48	-0.070	1.900	0.480	0.320
20	-2.850	-2.700	0.480	0.320	49	2.850	1.900	0.480	0.320
21	-2.850	-2.200	0.480	0.320	50	-1.200	0.270	0.670	0.670
22	-2.850	-1.700	0.480	0.320	51	0.000	0.270	0.670	0.670
23	-2.850	-1.200	0.480	0.320	52	1.200	0.270	0.670	0.670
24	-2.850	-0.700	0.480	0.320	53	-1.200	-0.800	0.670	0.670
25	-2.850	-0.200	0.480	0.320	54	0.000	-0.800	0.670	0.670
26	-2.850	0.300	0.480	0.320	55	1.200	-0.800	0.670	0.670
27	-2.850	0.800	0.480	0.320	56	-1.200	-1.870	0.670	0.670
28	-2.850	1.300	0.480	0.320	57	0.000	-1.870	0.670	0.670
29	-2.850	1.800	0.480	0.320	58	1.200	-1.870	0.670	0.670

Note:

- The dimensions in parenthesis are reference
- All dimensions in millimeters (mms)
- Unless otherwise specified tolerances are:
 - Decimal:
 - X.X = ± 0.1
 - X.XX = ± 0.05
 - X.XXX = ± 0.03
 - Angular: ± 0.1 (In Deg)
- Hatching lines means package shielding area
- Pad coordinates located from package center (0,0)
 - Dimensioning and Tolerance per ANSI Y14.5M-1994

8. Land Pattern

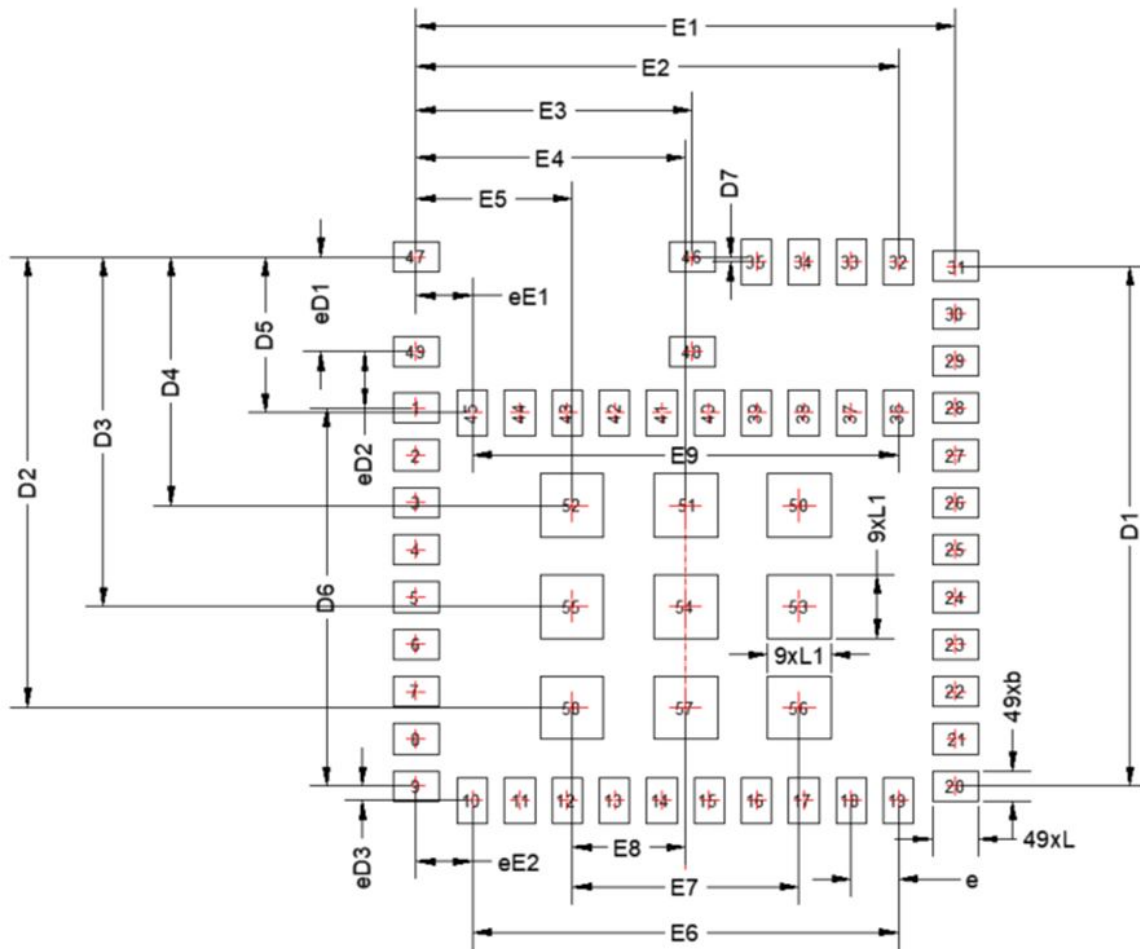

Figure 8.1. WFM200S Land Pattern

Table 8.1. PCB Land Pattern

Dimension	mm
b	0.32
D1	5.50
D2	4.77
D3	3.70
D4	2.63
D5	1.65
D6	4.00
D7	0.05
eD1	1.00
eD2	0.60
eD3	0.15
e	0.50

Dimension	mm
E1	5.70
E2	5.10
E3	2.92
E4	2.85
E5	1.65
E6	4.50
E7	2.40
E8	1.20
E9	4.50
L	0.48
L1	0.67
eE1	0.60
eE2	0.60

Notes:

1. General

- a. All feature sizes shown are at Maximum Material Condition (MMC) and a card fabrication tolerance of 0.05mm is assumed.
- b. Dimensioning and Tolerancing is per the ANSI Y14.5M-1994 specification.

2. Stencil Design

- a. A stainless steel, laser-cut and electro-polished stencil with trapezoidal walls should be used to assure good solder paste release.
- b. The stencil thickness should be 0.100mm (4 mils).
- c. The stencil aperture to land pad size recommendation is 80% paste coverage.

The above notes and stencil design are shared as recommendations only. A customer or user may find it necessary to use different parameters and fine tune their SMT process as required for their application and tooling.

Note: Recommendations regarding WFM200 handling and manufacturing are provided in [AN1223: LGA Manufacturing Guidance](#).

9. Top Marking

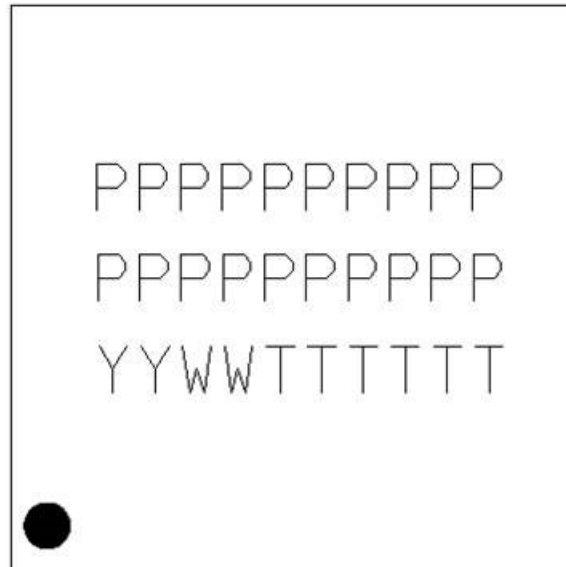

Figure 9.1. WFM200S Top Marking

Table 9.1. Top Marking Definition

OPN	Line 1 Marking	Line 2 Marking	Line 3 Marking
WFM200S022XNA3	WFM200SA	200022XNA3	See note below
WFM200SS22XNA3	WFM200SA	200S22XNA3	See note below
WFM200S022XNN3	WFM200SN	200022XNN3	See note below
WFM200SS22XNN3	WFM200SN	200S22XNN3	See note below
Note: YY = Year. WW = Work Week			

10. Tape and Reel Specifications

10.1 Tape and Reel Packaging

This section contains information regarding the tape and reel packaging for the WFM200S Module.

10.2 Reel and Tape Specifications

- Reel material: Polystyrene (PS)
- Reel diameter: 13 inches (330 mm)
- Number of modules per reel: 1000 pcs
- Disk deformation, folding whitening and mold imperfections: Not allowed
- Disk set: consists of two 13 inch (330 mm) rotary round disks and one central axis (100 mm)
- Antistatic treatment: Required
- Surface resistivity: $10^4 - 10^9 \Omega/\text{sq}$.

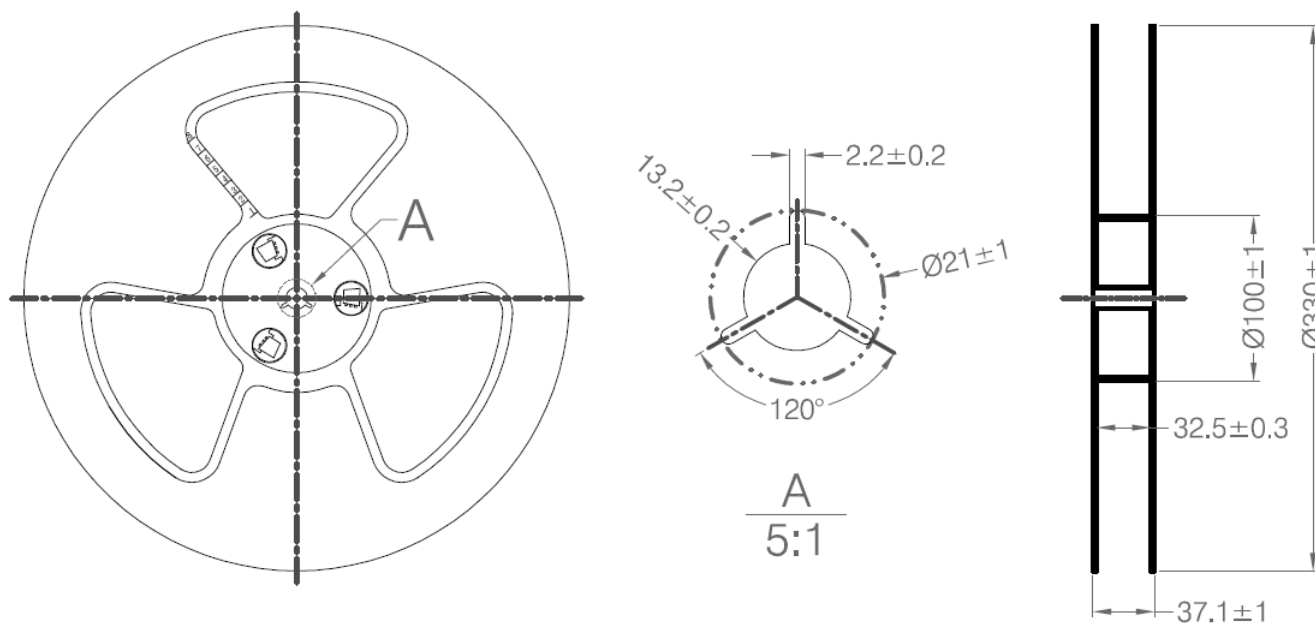

Figure 10.1. Reel Dimensions - Side View

Table 10.1. Reel Dimensions

Symbol	Dimensions [mm]
W0	32.5 ± 0.3
W1	37.1 ± 1.0

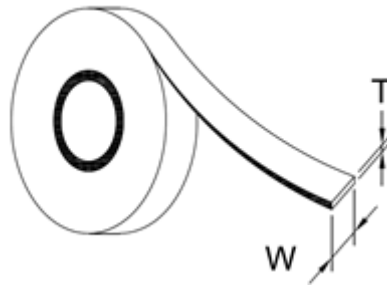

Figure 10.2. Cover tape information

Table 10.2. Cover Tape Dimensions

Symbol	Dimensions [mm]
Thickness (T)	0.061
Width (W)	25.5 + 0.2

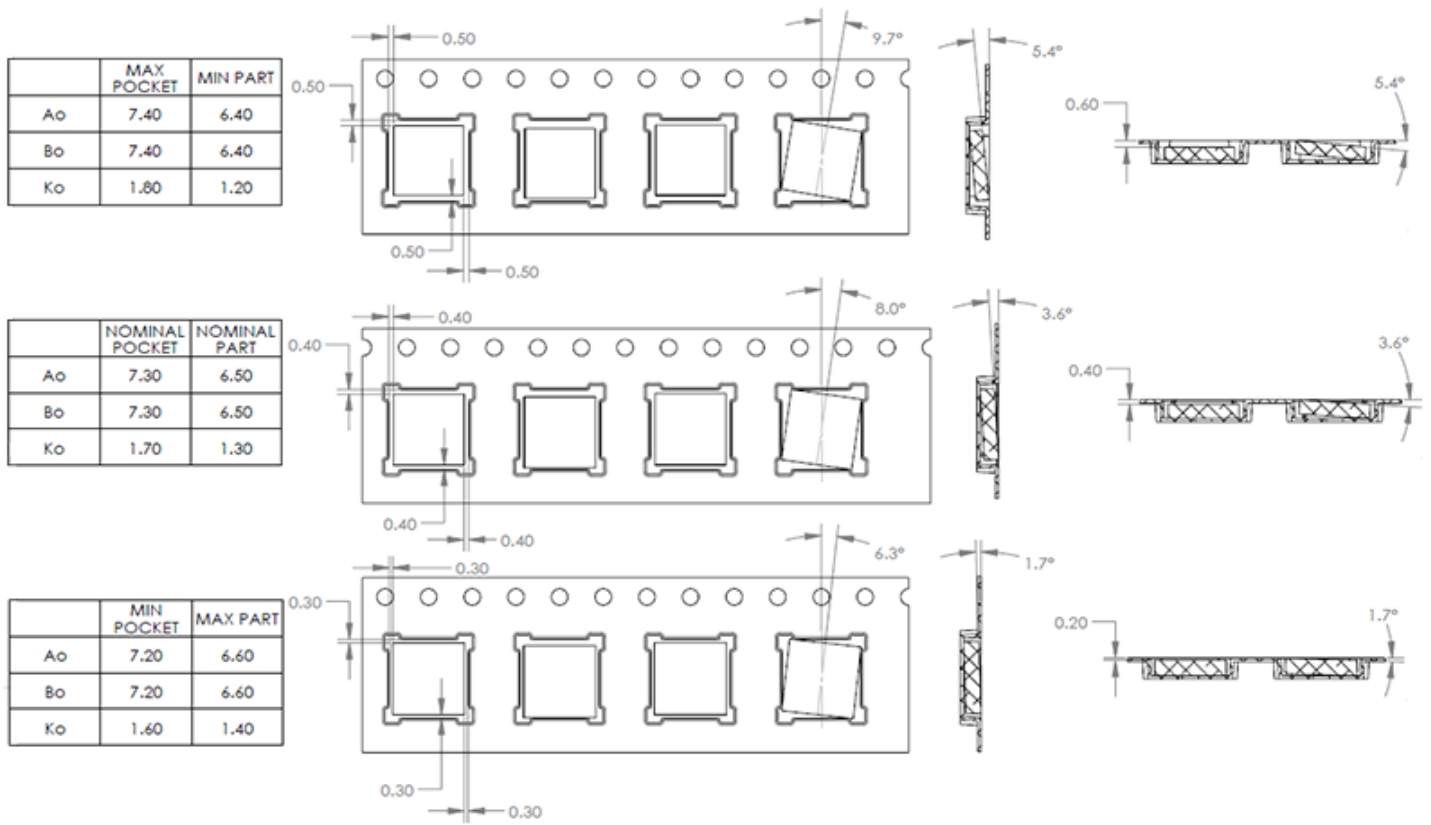

Figure 10.3. Tape information

10.3 Orientation and Tape Feed

The user direction of feed, start and end of tape on reel and orientation of the Modules on the tape are shown in the figures below.

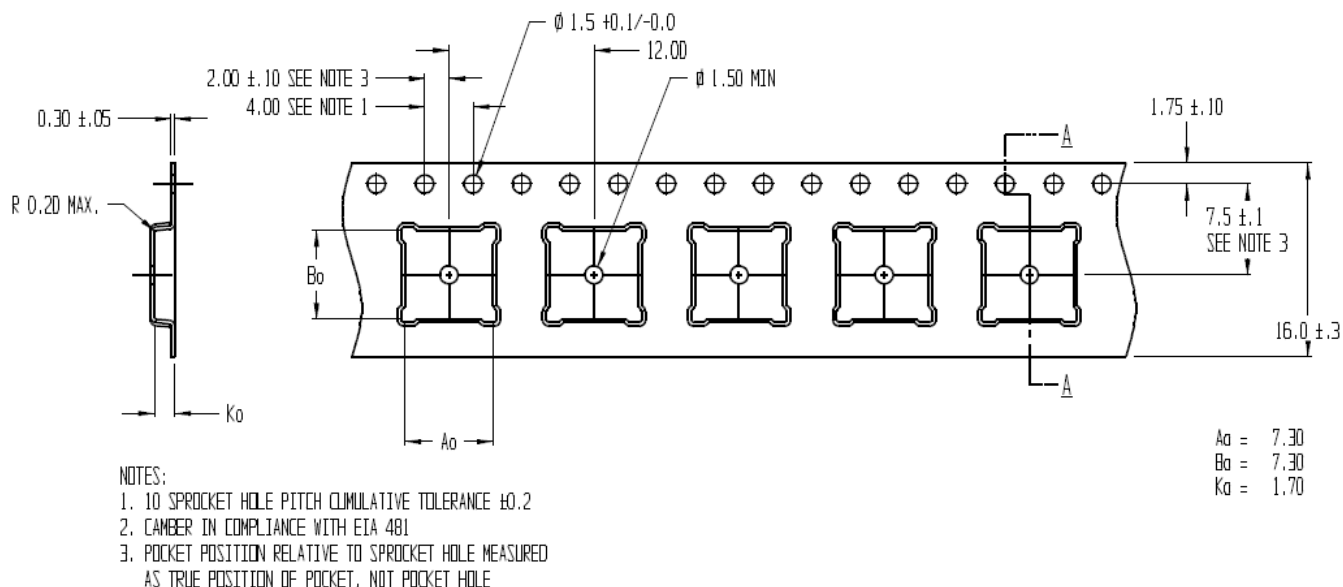

Figure 10.4. Module Orientation and Feed Direction

10.4 Tape and Reel Box Dimensions

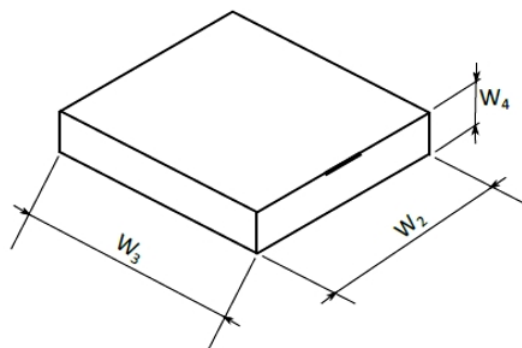

Figure 10.5. Tape and Reel Box Dimensions

Table 10.3. Tape and Reel Box Dimensions

Symbol	Dimensions [mm]
W_2	368
W_3	338
W_4	72

10.5 Moisture Sensitivity Level

Reels are delivered in packing which conforms to MSL3 (Moisture Sensitivity Level 3) requirements.

11. Software Reference

This section gives a short overview of the software involved to run applications based on this device. The firmware running in the WFM200S allows it to be used at Lower MAC level (in split MAC) or at the Upper Mac level (in Full MAC).

11.1 Host and Device Software

This device is intended to be used as a Network Co-Processor (NCP) which means that it requires a host processor to run the application. Depending on architecture choices based on required throughput, host memory size and power, the MAC layer can be split between WFM200S and its host or fully ran in WFM200S.

11.1.1 Split MAC

The so-called split MAC is the case where WFM200S runs the Lower MAC section while the host processor runs the Upper MAC. This is a use case that typically fits the Linux application as MAC802.11 is provided with Linux

For such an application, Silicon Labs provides the embedded firmware implementing the Lower MAC as well as needed configuration tasks. Sample core Linux drivers are available for a variety of platforms.

The figure below shows the typical software architecture in Split MAC implementations.

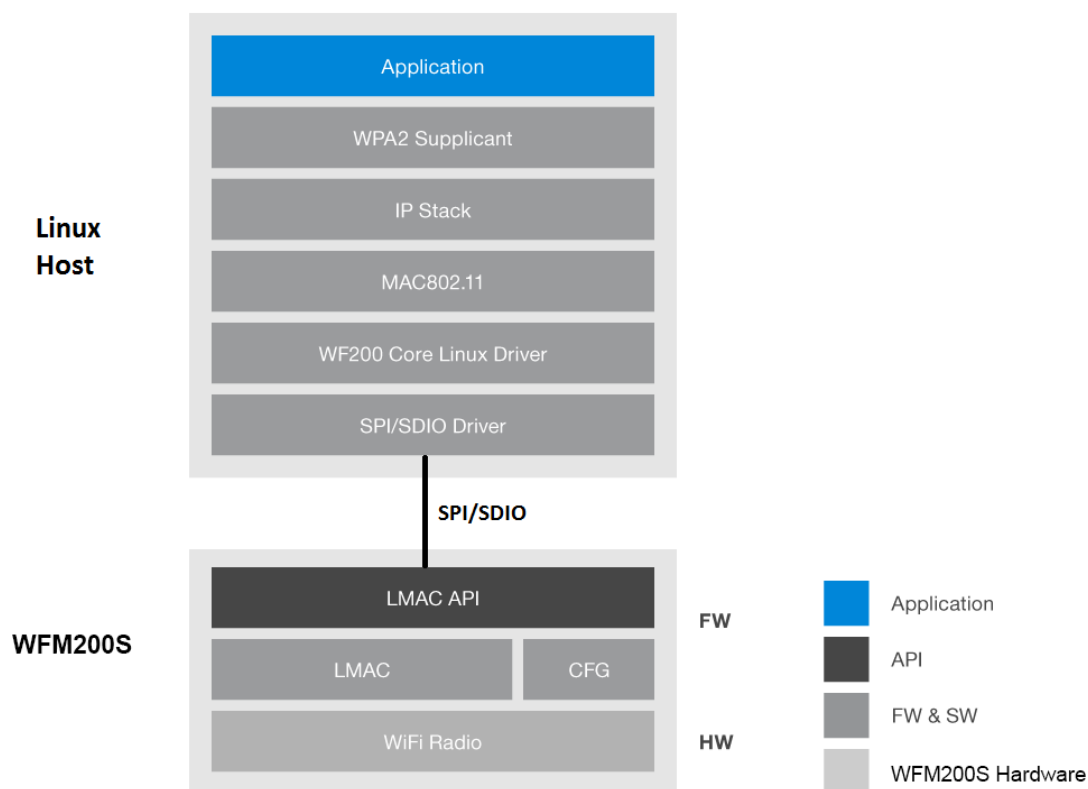

Figure 11.1. Split MAC Implementation

11.1.2 Full MAC

In this scenario, both the lower MAC and upper MAC are running in WFM200S. The WFM200S contains a WPA/WPA2 personal supplicant, allowing it to handle full MAC responsibilities without utilizing the host MCU. The host receives an IP packet and implements all stack layers necessary above it.

The figure below shows the typical software architecture in Full MAC implementations.

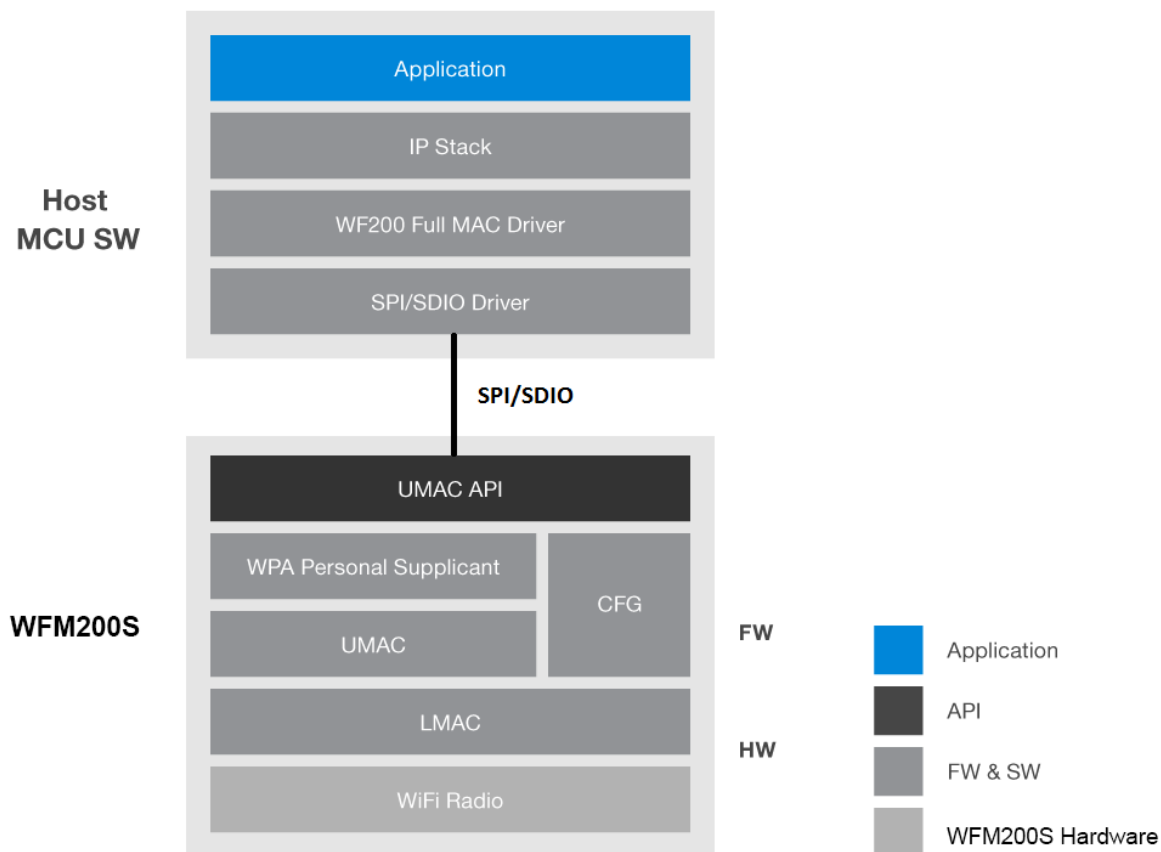

Figure 11.2. Full MAC Implementation

Note: The WPA supplicant on WFM200S does not support WPA enterprise. If WPA-enterprise is required, then it should be implemented above the IP stack in the host MCU software.

11.1.3 Software Documentation

Documentation required for software implementation is available at <https://docs.silabs.com/>.

11.2 Security

The WFM200S implements several security features as listed below.

11.2.1 Secure Device

WFM200S disables access to all debug ports.

11.2.2 Secure Boot

Secure Boot includes several features related to boot and firmware security. Firmware authentication and encryption do not have any impact on host software, whereas firmware roll back prevention requires more flexibility and is managed by each customer through software.

- Firmware authentication: The downloaded firmware is authenticated such that only Firmware provided by Silicon Labs can run in WFM200S.
- Firmware encryption: The downloaded firmware is encrypted when generated by Silicon Labs and is decrypted inside WFM200S during firmware download.
- Firmware roll back prevention: If a security threat is discovered, Silicon Labs has the ability to increment in its firmware an anti-roll-back tag. This can be used by the customer to prevent the part from starting with a firmware having a tag lower than a specified one. This mechanism is managed by each customer on a case-by-case need.

11.2.3 Secure Link (WFM200SS only)

Secure Link refers to the capability to have encrypted SPI/SDIO communication between the host and WFM200S. This feature requires the host and WFM200S to exchange a key based on a shared secret stored on both sides nonvolatile secured memories and programmed at the end product manufacturing stage. The encrypted interface uses a Diffie-Hellman algorithm key exchanges on a per session/per device basis. As a result, a given link is secured uniquely on a given device, and keys are regenerated on a power cycle.

There are 3 possible cases for secure link:

- Secure link is not used: In this scenario, the part does not encrypt any communication with the host.
- Secure link is temporary enabled: Secure Link can be activated through software, with a software key which is not stored in WFM200S. Doing this allows to assess the performance and consumption impacts of secure link. In this mode, Secure Link is achieved as long as the part is not reset. The next restart of WFM200S will make it start in Non-Secure Link mode.
- Permanent Secure Link: This mode is activated by software and the key exchanged is permanently stored in WFM200S non-volatile memory. Once configured in this mode, WFM200S only understands host interface messages which have been encrypted with the stored key.

Once a secure link has been established, the host can choose to only encrypt certain API messages between the host and the WFM200S to reduce the power and latency overhead of encryption.

11.3 Startup, Sleep and Shutdown

11.3.1 Power On, Reset, and Boot

When RESETE_n pin is set HIGH, WFM200S is getting out of its reset mode. All supply voltages should be settled within the operational range before the rising edge of RESETE_n pin. Then the boot sequence can be initiated by the host software with the following sequence:

- Some registers describing the required configuration before firmware download are written by the driver.
- The driver initiates the boot.
- The driver downloads the embedded firmware into WFM200S.
- The driver configures WFM200S upon the hardware platform and requested features with a dedicated configuration file.

11.3.2 Sleep and Snooze Modes

The sleep or snooze modes are reached when power-save mode has been enabled on the WFM200S. These modes highly reduce power consumption while maintaining all configuration and context, so that the device can be quickly back to normal operation. A WFM200S driver command is used to indicate that the driver wants the part to go to power-save. However it is the firmware on WFM200S that decides when it switches into sleep mode based on Wi-Fi activity.

The part wake-up is achieved by asserting the GPIO/WUP pin.

The sleep mode requires a 32 KHz clock to be provided on LP_CLK pin.

In case a 32 KHz clock is not available, the part can be set in a snooze mode which is functionally equivalent but draws more current.

11.3.3 Shutdown Mode

The shutdown mode can be used if the Wi-Fi feature is not needed for a long period of time. This mode achieves the lowest current consumption on the device but requires a full power-up reset and boot sequence to come back to the operational mode. This mode should be initiated by the host.

Note: A similar behavior could be achieved by asserting RESETn pin low, but would draw more current.

12. Certifications

This section details certification status of the module in various regions.

The address for the module manufacturer and certification applicant is:

SILICON LABORATORIES FINLAND OY
Alberga Business Park, Bertel Jungin aukio 3,
02600 Espoo, Finland

Refer to AN1048 for more information related to Regulatory Certifications.

12.1 Qualified External Antenna Types

This device has been certified with an embedded antenna with an external loop as well as external dipole whip antennas connected to either RF port or both. The required antenna impedance is 50 Ω .

Table 12.1. Qualified Antennas for WFM200S

Antenna Type	Maximum Gain
Connectorized Coaxial Dipole	4.7 dBi

Any antenna of the same general type and of equal or less directional gain as listed in the above table can be used in the regulatory areas that have a full modular radio approval (USA, Canada, Korea, Japan) as long as spot-check testing is performed to verify that no performance changes compromising compliance have been introduced. In countries applying the ETSI standards, like the EU countries, the radiated emissions are always tested with the end-product and the antenna type is not critical, but antennas with higher gain may violate some of the regulatory limits.

If an antenna of a different type (such as a patch antenna) with a gain less than or equal to 4.7 dBi is needed, it can be added as a permissive change, requiring some radiated emission testing. Antenna types with more gain than 4.7 dBi may require a fully new certification. Since the exact permissive change procedure is chosen on a case by case basis, please consult your test house, for example while performing with them the EMC testing of the end-product.

The use of this certified module requires all applications to adhere to UG395: WFM200 Hardware Design User's Guide.

12.2 CE and UKCA - EU and UK

The WFM200SA and WFM200SN modules have been tested against the relevant harmonized/designated standards and are in conformity with the essential requirements and other relevant requirements of the Radio Equipment Directive (RED) (2014/53/EU) and of the Radio Equipment Regulations (RER) (S.I. 2017/1206).

Please notice that every end-product integrating a WFM200SA or WFM200SN module will need to perform the radio EMC tests on the whole assembly, according to the ETSI 301 489-x relevant standards.

Furthermore, it is ultimately the responsibility of the manufacturer to ensure the compliance of the end-product as a whole. The specific product assembly is likely to have an impact to RF radiated characteristics, when compared to the bare module. Hence, manufacturers should carefully consider RF radiated testing with the final product assembly, especially taking into account the gain of the external antenna if any, and the possible deviations in the PSD, EIRP and spurious emissions measurements, as defined in the ETSI 300 328 standard.

The modules are entitled to carry the CE and UKCA Marks, and a formal Declaration of Conformity (DoC) is available at the product web page which is reachable starting from <https://www.silabs.com/>.

To ensure full conformity for CE, the end-product manufacturer is supposed to set the CCA to Absolute Mode, and to make sure the max RF TX power levels are configured appropriately, primarily based on the system antenna gain (the [UG395: WFM200 Hardware Design User's Guide](#) comes with a table showing configuration examples of this.)

12.3 FCC - USA

This device complies with Part 15 of the FCC Rules. Operation is subject to the following two conditions:

1. This device may not cause harmful interference, and
2. This device must accept any interference received, including interference that may cause undesirable operation.

Any changes or modifications not expressly approved by Silicon Labs could void the user's authority to operate the equipment.

FCC RF Radiation Exposure Statement:

This equipment complies with FCC radiation exposure limits set forth for an uncontrolled environment. End users must follow the specific operating instructions for satisfying RF exposure compliance. This transmitter meets both portable and mobile requirements in accordance to the limits exposed in the RF Exposure Analysis. This transmitter must not be co-located or operating in conjunction with any other antenna or transmitter except in accordance with FCC multi-transmitter product procedures.

OEM Responsibilities to comply with FCC Regulations:

OEM integrator is responsible for testing their end-product for any additional compliance requirements needed with this module installed (for example, digital device emissions, PC peripheral requirements, etc.). Additionally, investigative measurements and spot checking are strongly recommended to verify that the full system compliance is maintained when the module is integrated, in accordance to the "Host Product Testing Guidance" in FCC's KDB 996369 D04 Module Integration Guide V01.

- See the table in the Section [12.7 Locating the Module Close to Human Body](#) for information on the minimum spacing between the module and the human body. This transmitter meets the Portable requirements at distances equal or above 23 mm.
- The transmitter module must not be co-located or operating in conjunction with any other antenna or transmitter except in accordance with FCC multi-transmitter product procedures.

Important Note:

In the event that these conditions cannot be met, then for the FCC authorization to remain valid the final product will have to undergo additional testing to evaluate the RF exposure, and a permissive change will have to be applied with the help of the customer's own Telecommunication Certification Body.

End Product Labeling

The outside of the device into which the module is installed must also display a label referring to the enclosed module. In that case, the final end product must be labeled in a visible area with the following:

"Contains Transmitter Module FCC ID: QQQWFM200"

Or

"Contains FCC ID: QQQWFM200"

The OEM integrator has to be aware not to provide information to the end user regarding how to install or remove this RF module or change RF related parameters in the user manual of the end product.

12.4 ISED - Canada

ISED

This radio transmitter (WFM200S) has been approved by *Innovation, Science and Economic Development Canada (ISED Canada, formerly Industry Canada)* to operate with the antenna types listed above, with the maximum permissible gain indicated. Antenna types not included in this list, having a gain greater than the maximum gain listed, are strictly prohibited for use with this device.

This device complies with ISED's license-exempt RSS standards. Operation is subject to the following two conditions:

1. This device may not cause interference; and
2. This device must accept any interference, including interference that may cause undesired operation of the device

RF Exposure Statement

Exemption from routine SAR evaluation limits are given in RSS-102 Issue 5.

See the Section 12.6 "Locating the Module Close to Human Body" for details on minimum spacing between the module and the human body

In other words, RF exposure or SAR evaluation is not required when the separation distance is same or more than stated above. If the separation distance is less than stated above the OEM integrator is responsible for evaluating the SAR when using the module at its highest transmission power.

OEM Responsibilities to comply with IC Regulations

The WFM200S modules have been certified for integration into products only by OEM integrators under the following conditions:

- The antenna(s) must be installed such that a minimum separation distance as stated above is maintained between the radiator (antenna) and all persons at all times. For Portable use cases, RF exposure or SAR evaluation is not required when the separation distances from the human body are equal or above 40 mm.
- The transmitter module must not be co-located or operating in conjunction with any other antenna or transmitter.

As long as the two conditions above are met, further transmitter testing will not be required. However, the OEM integrator is still responsible for testing their end-product for any additional compliance requirements required with this module installed (for example, digital device emissions, PC peripheral requirements, etc.).

IMPORTANT NOTE

In the event that these conditions cannot be met, then for the ISED authorization to remain valid the final product will have to undergo additional testing to evaluate the RF exposure, and a permissive change will have to be applied with the help of the customer's own Telecommunication Certification Body.

End Product Labeling

The outside of the device into which the module is installed must also display a label referring to the enclosed module. In that case, the final end product must be labeled in a visible area with the following:

"Contains Transmitter Module IC: 5123A-WFM200 "

or

"Contains IC: 5123A-WFM200"

The OEM integrator has to be aware not to provide information to the end user regarding how to install or remove this RF module or change RF related parameters in the user manual of the end product.

ISED (Français)

ISED a approuvé l'utilisation de cet émetteur radio (WFM200S) en conjonction avec des antennes de type dipolaire à 2.14dBi ou de son antenne intégrée. L'utilisation de tout autre type d'antenne avec ce composant est proscrite.

Ce composant est conforme aux normes RSS, exonérées de licence d'ISED. Son mode de fonctionnement est soumis aux deux conditions suivantes:

1. Ce composant ne doit pas générer d'interférences.
2. Ce composant doit pouvoir être soumis à tout type de perturbation y compris celle pouvant nuire à son bon fonctionnement.

Déclaration d'exposition RF

L'exemption tirée des limites courantes d'évaluation DAS est donnée dans le document RSS-102 Issue 5.

Reportez-vous à la Section 12.6 "Localisation du module près du corps humain" pour obtenir des informations sur l'espacement minimal entre le module et le corps humain. Pour les cas d'utilisation Portables, l'exposition aux fréquences radio ou l'évaluation du SAR n'est pas nécessaire lorsque les distances de séparation du corps humain sont égales ou supérieures à 40 mm.

Pour les cas d'utilisation Portables, l'exposition aux fréquences radio ou l'évaluation du SAR n'est pas nécessaire lorsque les distances de séparation du corps humain sont égales ou supérieures à 40 mm

La déclaration d'exposition RF ou l'évaluation DAS n'est pas nécessaire lorsque la distance de séparation est identique ou supérieure à celle indiquée ci-dessus. Si la distance de séparation est inférieure à celle mentionnées plus haut, il incombe à l'intégrateur OEM de procéder à une évaluation DAS.

Responsabilités des OEM pour une mise en conformité avec le Règlement du Circuit Intégré

Le module WFM200S a été approuvé pour l'intégration dans des produits finaux exclusivement réalisés par des OEM sous les conditions suivantes:

- L'antenne (s) doit être installée de sorte qu'une distance de séparation minimale indiquée ci-dessus soit maintenue entre le radiateur (antenne) et toutes les personnes avoisinante, ce à tout moment.
- Le module émetteur ne doit pas être localisé ou fonctionner avec une autre antenne ou un autre transmetteur que celle indiquée plus haut.

Tant que les deux conditions ci-dessus sont respectées, il n'est pas nécessaire de tester ce transmetteur de façon plus poussée. Cependant, il incombe à l'intégrateur OEM de s'assurer de la bonne conformité du produit fini avec les autres normes auxquelles il pourrait être soumis de fait de l'utilisation de ce module (par exemple, les émissions des périphériques numériques, les exigences de périphériques PC, etc.).

REMARQUE IMPORTANTE

Dans le cas où ces conditions ne peuvent être satisfaites (pour certaines configurations ou co-implantation avec un autre émetteur), l'autorisation ISED n'est plus considérée comme valide et le numéro d'identification ID IC ne peut pas être apposé sur le produit final. Dans ces circonstances, l'intégrateur OEM sera responsable de la réévaluation du produit final (y compris le transmetteur) et de l'obtention d'une autorisation ISED distincte.

Étiquetage des produits finis

Le produit dans lequel le module est installé devra porter une étiquette faisant apparaître la référence du module intégré. Dans un tel cas, sur le produit final doit se trouver une étiquette aisément lisible sur laquelle figurent les informations suivantes:

“Contient le module transmetteur IC: 5123A-WFM200 ”

ou

“Contient le circuit IC: 5123A-WFM200”

L'intégrateur OEM doit être conscient qu'il ne doit pas fournir, dans le manuel d'utilisation, d'informations relatives à la façon d'installer ou de d'enlever ce module RF ainsi que sur la procédure à suivre pour modifier les paramètres liés à la radio.

12.5 MIC - Japan

The WFM200S modules are certified in Japan with certification number 006-000781

Since September 1, 2014 it is allowed (and highly recommended) that a manufacturer who integrates a radio module in their host equipment places the certification mark and certification number on the outside of the host equipment (same marking/number might also appear on the label of the radio module). The certification mark and certification number must be placed close to the text in the Japanese language which is provided below. This change in the Radio Law has been made in order to enable users of the combination of host and radio module to verify if they are actually using a radio device which is approved for use in Japan.

Certification Text to be Placed on the Outside Surface of the Host Equipment:

当該機器には電波法に基づく、技術基準適合証明等を受けた特定無線設備を装着している。

Translation of the text:

"This equipment contains specified radio equipment that has been certified to the Technical Regulation Conformity Certification under the Radio Law."

The "Giteki" mark shown in the following figures must be affixed to an easily noticeable section of the specified radio equipment.

Note: Additional information may be required if the device is also subject to a telecom approval.



Figure 12.1. GITEKI Mark and ID

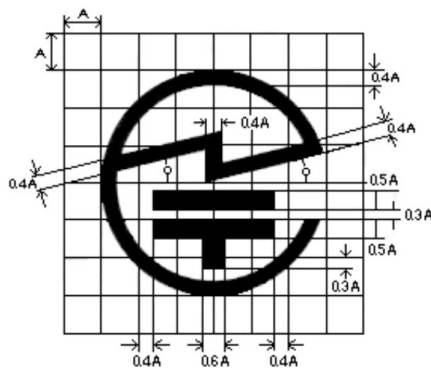

Figure 12.2. Detail of GITEKI Mark

12.6 KC - South Korea

The WFM200S modules have a RF certification for import and use in South-Korea.

Certification number is: R-C-BGT-WFM200

The maximum transmit power of the module is 15.1dBm (32.36mW), but due to the wide bandwidth of the communication channels, it still meets the limit of 10mW/MHz in the Korean regulations.

Memory buffers and low-voltage circuits can withstand very high data rates.

When integrating the RF-certified module, an end-product is automatically compliant to the local RF regulations and thus exempted from doing RF emission testing, as long as the recommended design guidance is followed, the approved antennas are used, and any additional transmit power backoff is implemented in accordance to the measurements and configurations seen in the test report.

EMC testing, and any other relevant test, might still be required for the full compliance of the end-product.

12.7 Locating the Module Close to Human Body

When using the module in an application where the radio is located close to human body, the human RF exposure must be evaluated. FCC, ISED, and CE all have different standards for evaluating the RF exposure, and because of this, each standard will require a different minimum separation distance between the module and human body. Certification of WFM200S allows for the minimum separation distances detailed in [Table 12.2 Minimum Separation Distances for SAR Evaluation Exemption on page 44](#) in Portable use cases (less than 20 cm from human body). The module is approved for the Mobile use case (more than 20 cm) without any need for RF exposure evaluation.

Table 12.2. Minimum Separation Distances for SAR Evaluation Exemption

Certification	WFM200S with embedded antenna	WFM200S with external reference dipole antenna
FCC	23 mm	23 mm
ISED	40 mm	40 mm
CE	The RF exposure must always be evaluated using the end-product when transmitting with power levels higher than 20 mW = 13 dBm.	

For FCC and ISED, using the module in end products where the separation distance is smaller than those listed above is allowed but requires evaluation of the RF exposure in the final assembly and applying for a *Class 2 Permissive Change* or *Change of ID* to be applied to the existing FCC/ISED approvals of the module. For CE, RF exposure must be evaluated using the end-product in all cases.

Note: Placing the module in touch or very close to the human body will have a negative impact on the efficiency of the antenna thus reducing range.

13. Revision History

Revision 1.2

December 2021

- Updated certifications to reflect UK specifics: [Section 1. Features List](#) and [Section 12.2 CE and UKCA - EU and UK](#)
- Updated [Section 5.1 Typical Application Circuit for SDIO Host Interface](#)
- Updated [Section 5.2 Typical Application Circuit for SPI Host Interface](#)

Revision 1.1

November 2020

- Updated [Figure 8.1 WFM200S Land Pattern](#) on page 29

Revision 1.0

September 2020

- Updated [Table 2.1 WFM200S Ordering Information \(R indicates Full Reel\)](#) on page 3
- Updated [Table 9.1 Top Marking Definition](#) on page 31

December 2019

- Updated [Section 4.4 RF Transmitter General Characteristics](#) and [Section 4.4.1 RF Transmitter Characteristics](#)
- Updated [Section 8. Land Pattern](#)
- Updated [Table 4.1 Absolute Maximum Ratings](#) on page 8
- Added [Section 12.5 MIC - Japan](#) and [Section 12.6 KC - South Korea](#)
- Added reference to AN1048 in [12. Certifications](#) section

Revision 0.51

November 2019

- Minor updates to [Certifications](#) section
- Correction to block diagrams

Revision 0.5

September 2019

- Updated [Sections 2,3, and 5](#) with new text
- Minor specification updates in [section 4](#)

Revision 0.32

August 2019

- Added [Certifications](#) section

Revision 0.31

August 2019

- Updated pin description for pin 47

Revision 0.3

July 2019

- Updated [Pin Descriptions](#), [Package Outline](#) and [Land Pattern](#) sections with new pinout

Smart. Connected. Energy-Friendly.



IoT Portfolio
www.silabs.com/products



Quality
www.silabs.com/quality



Support & Community
www.silabs.com/community

Disclaimer

Silicon Labs intends to provide customers with the latest, accurate, and in-depth documentation of all peripherals and modules available for system and software implementers using or intending to use the Silicon Labs products. Characterization data, available modules and peripherals, memory sizes and memory addresses refer to each specific device, and “Typical” parameters provided can and do vary in different applications. Application examples described herein are for illustrative purposes only. Silicon Labs reserves the right to make changes without further notice to the product information, specifications, and descriptions herein, and does not give warranties as to the accuracy or completeness of the included information. Without prior notification, Silicon Labs may update product firmware during the manufacturing process for security or reliability reasons. Such changes will not alter the specifications or the performance of the product. Silicon Labs shall have no liability for the consequences of use of the information supplied in this document. This document does not imply or expressly grant any license to design or fabricate any integrated circuits. The products are not designed or authorized to be used within any FDA Class III devices, applications for which FDA premarket approval is required or Life Support Systems without the specific written consent of Silicon Labs. A “Life Support System” is any product or system intended to support or sustain life and/or health, which, if it fails, can be reasonably expected to result in significant personal injury or death. Silicon Labs products are not designed or authorized for military applications. Silicon Labs products shall under no circumstances be used in weapons of mass destruction including (but not limited to) nuclear, biological or chemical weapons, or missiles capable of delivering such weapons. Silicon Labs disclaims all express and implied warranties and shall not be responsible or liable for any injuries or damages related to use of a Silicon Labs product in such unauthorized applications.

Note: This content may contain offensive terminology that is now obsolete. Silicon Labs is replacing these terms with inclusive language wherever possible. For more information, visit www.silabs.com/about-us/inclusive-lexicon-project

Trademark Information

Silicon Laboratories Inc., Silicon Laboratories®, Silicon Labs®, SiLabs® and the Silicon Labs logo®, Bluegiga®, Bluegiga Logo®, EFM®, EFM32®, EFR, Ember®, Energy Micro, Energy Micro logo and combinations thereof, “the world’s most energy friendly microcontrollers”, Redpine Signals®, WiSeConnect®, n-Link, ThreadArch®, EZLink®, EZRadio®, EZRadioPRO®, Gecko®, Gecko OS, Gecko OS Studio, Precision32®, Simplicity Studio®, Telegesis, the Telegesis Logo®, USBXpress®, Zentri, the Zentri logo and Zentri DMS, Z-Wave®, and others are trademarks or registered trademarks of Silicon Labs. ARM, CORTEX, Cortex-M3 and THUMB are trademarks or registered trademarks of ARM Holdings. Keil is a registered trademark of ARM Limited. Wi-Fi is a registered trademark of the Wi-Fi Alliance. All other products or brand names mentioned herein are trademarks of their respective holders.



Silicon Laboratories Inc.
400 West Cesar Chavez
Austin, TX 78701

Looking for pricing, stock, or lifecycle information?

Click below to explore more details on WIN SOURCE:

 [View UPM1H471MHD on WIN SOURCE](#)

 [Nichicon Information](#)

Optimize Your Supply Chain with WIN SOURCE Solutions

-  Global Sourcing Solution
-  Obsolete Management
-  Cost Control Management
-  Shortage Management
-  Alternative Solution
-  Excess Inventory Management