



**THE DATASHEET OF
XM7B-0442**



2011/12/15 03:54:57 CAROL TRIBBLE

DRAWING FOR REFERENCE: This is subject to change without notice

TO

COUNT	DESCRIPTION OF REVISIONS	BY	CHKD	DATE	COUNT	DESCRIPTION OF REVISIONS	BY	CHKD	DATE	
△					△					
△					△					
APPLICABLE STANDARD		USB2.0 SPECIFICATION AND MICRO-USB CABLES AND CONNECTORS SPECIFICATION								
RATING	OPERATING TEMPERATURE RANGE	-30 °C TO +85 °C			STORAGE TEMPERATURE RANGE	-30 °C TO +85 °C				
	VOLTAGE	AC 30V			OPERATING HUMIDITY RANGE	— % TO — %				
	CURRENT	① 1 A/pin ① SIGNAL ONLY ② 1.8 A/pin (PIN No.1,5) ② POWER APPLY 0.5 A/pin (PIN No.2-4)			APPLICABLE CABLE	—				
SPECIFICATIONS										
ITEM	TEST METHOD				REQUIREMENTS				QT	AT
CONSTRUCTION										
GENERAL EXAMINATION	VISUALLY AND BY MEASURING INSTRUMENT.				ACCORDING TO DRAWING.				×	×
MARKING	CONFIRMED VISUALLY.								×	×
ELECTRICAL CHARACTERISTICS										
CONTACT RESISTANCE	100 mA (DC OR 1000 Hz).				30 mΩ MAX.				×	×
INSULATION RESISTANCE	500 V DC.				100 MΩ MIN.				×	×
VOLTAGE PROOF	100 V AC FOR 1 min.				NO FLASHOVER OR BREAKDOWN.				×	×
CAPASITANCE	MEASURE ADJACENT TWO CONTACTS AT 1000±10Hz AC VOLTAGE.				2 pF MAX				×	—
MECHANICAL CHARACTERISTICS										
INSERTION AND WITHDRAWAL FORCES	A MAXIMUM RATE OF 12.5mm/min. MEASURED BY APPLICABLE CONNECTOR.				INSERTION FORCE 35 N MAX. WITHDRAWAL FORCE 8 N MIN.				×	—
MECHANICAL OPERATION	10000 TIMES INSERTIONS AND EXTRACTIONS. MATING SPEED - MECHANICALLY OPERATED : 500 CYCLES / h - MANUALLY OPERATED : 200 CYCLES / h				① CONTACT RESISTANCE : NO INCREASE OF MORE THAN 10 mΩ FROM INITIAL VALUE. ② INSERTION FORCE 35 N MAX. WITHDRAWAL FORCE 8 N MIN. ③ NO DAMAGE, CRACK AND LOOSENESS, OF PARTS.				×	—
VIBRATION	FREQUENCY 10 TO 55 Hz, SINGLE AMPLITUDE 0.75 mm, AT 2 h, FOR 3 AXIAL DIRECTIONS, TOTAL 6 h.				① NO ELECTRICAL DISCONTINUITY OF 1 μs. ② NO DAMAGE, CRACK AND LOOSENESS, OF PARTS.				×	—
RANDOM VIBRATION	FREQUENCY 50 TO 2000 Hz, AT 15 min, FOR 3 AXIAL DIRECTIONS.								×	—
SHOCK	490m/s ² DIRECTIONS OF PULSE 11 ms AT 3 TIMES FOR 6 DIRECTIONS, TOTAL 18 TIMES.								×	—
ENVIRONMENTAL CHARACTERISTICS										
THERMAL SHOCK	TEMP -55 → 15 TO 35 → 85 → 15 TO 35 °C TIME 30 → 2 TO 3 → 30 → 2 TO 3 min UNDER 10 CYCLES. (MATED WITH APPLICABLE CONNECTOR)				① CONTACT RESISTANCE : 70 mΩ MAX. ② INSULATION RESISTANCE : 10 MΩ MIN. ③ NO DAMAGE, CRACK AND LOOSENESS, OF PARTS.				×	—
HUMIDITY LIFE	TEMPERATURE -10~65 °C, HUMIDITY 90 TO 98 %, UNDER 7 CYCLES (168 h) (MATED WITH APPLICABLE CONNECTOR)				NO DAMAGE, CRACK AND LOOSENESS, OF PARTS.				×	—
REMARKS	HIROSE will not guarantee the performance on these specifications in case this product will be mated with the others which is not HIROSE's.				DRAWN	DESIGNED	CHECKED	APPROVED	RELEASED	
				<i>Fong Wong</i>	<i>M. Shimoyama</i>	<i>J. Aso</i>	<i>N. Mizoguchi</i>			
Unless otherwise specified, refer to USB2.0 or EIA364				08.4.14	08.4.14	08.04.14	08.04.15			
Note QT:Qualification Test AT:Assurance Test ×:Applicable Test										
HRS HIROSE ELECTRIC CO., LTD.				SPECIFICATION SHEET				PART NO. ZX80-B-5P		
CODE NO.(OLD)			DRAWING NO. ELC4-126723			CODE NO. CL242-0051-0			1/2	



TO

SPECIFICATIONS				
ITEM	TEST METHOD	REQUIREMENTS	QT	AT
DRY HEAT	EXPOSED AT +85±2 °C, 96 h. (MATED WITH APPLICABLE CONNECTOR)	NO DAMAGE, CRACK AND LOOSENESS, OF PARTS.	×	—
COLD	EXPOSED AT -40±2 °C, 96 h. (MATED WITH APPLICABLE CONNECTOR)	NO DAMAGE, CRACK AND LOOSENESS, OF PARTS.	×	—
CORROSION SALT MIST	EXPOSED IN 5 % SALT WATER, 35 °C FOR 48 h. (LEFT UNDER UNMATED CONDITION)	NO HEAVY CORROSION.	×	—
SOLDERABILITY	SOLDERING POINT IMMERSSED IN SOLDER BATH OF 255±5 °C, 5sec.(USING TYPE R FLUX)	SOLDER SHALL COVER MINIMUM OF 95 % OF THE SURFACE BEING IMMERSSED.	×	—
RESISTANCE TO SOLDERING HEAT	A PROFILE IS SHOWN IN FIG-1, UNDER 2 CYCLES	NO DEFORMATION OR SIGNIFICANT LOOSENESS OF CONTACTS.	×	—

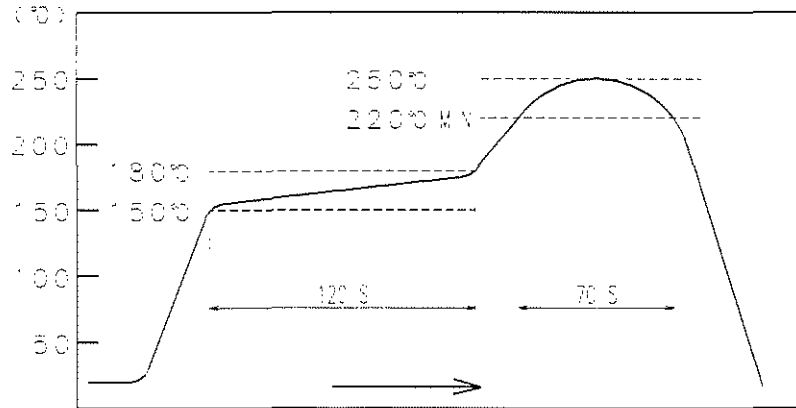

FIG - 1 RESISTANCE TO SOLDERING HEAT
(TEMPERATURE AT TOP SURFACE OF CONNECTOR)

■ RECOMMENDED PROFILE REFERS TO FIG - 2.
(TEMPERATURE AT SMT LEADS)

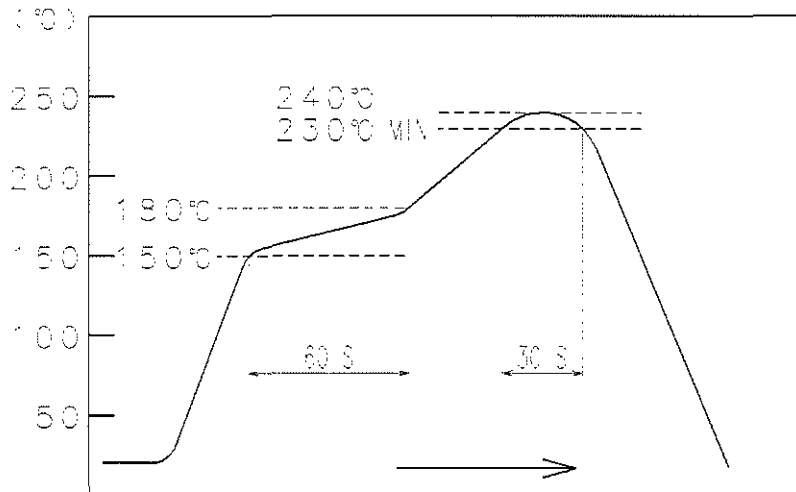

FIG - 2 RECOMMENDED REFLOW PROFILE TEMPERATURE

REMARKS HIROSE will not guarantee the performance on these specifications in case this product will be mated with the others which is not HIROSE's. Unless otherwise specified, refer to USB2.0 or EIA364	DRAWN	DESIGNED	CHECKED	APPROVED	RELEASED
	<i>Feng Wang</i> 08.4.15	<i>M. Shioyama</i> 08.4.15	<i>J. Asu</i> 08.04.15	<i>N. Miyoshi</i> 08.04.15	

Note QT:Qualification Test AT:Assurance Test X:Applicable Test

HRS HIROSE ELECTRIC CO., LTD.	SPECIFICATION SHEET	PART NO. ZX80-B-5P
CODE NO.(OLD)	DRAWING NO. ELC4-126723	CODE NO. CL242-0051-0

2 / 2



TO	

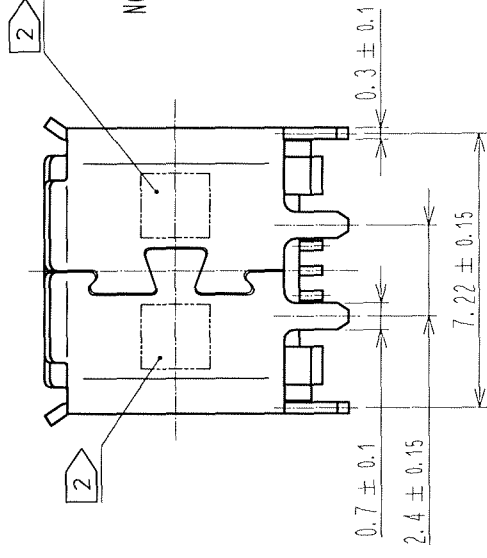
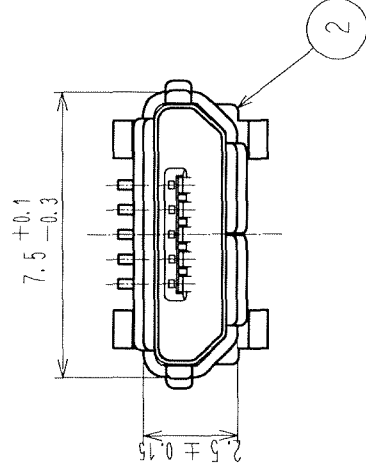
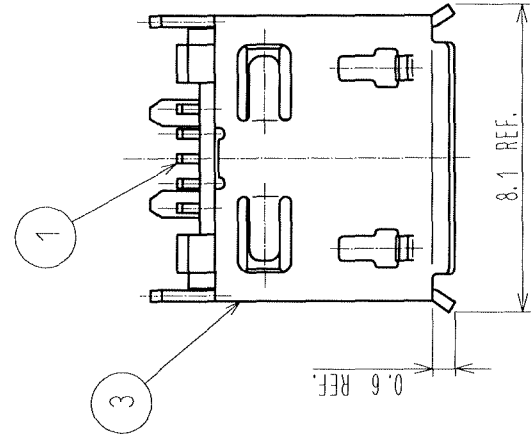

PCB LAYOUT

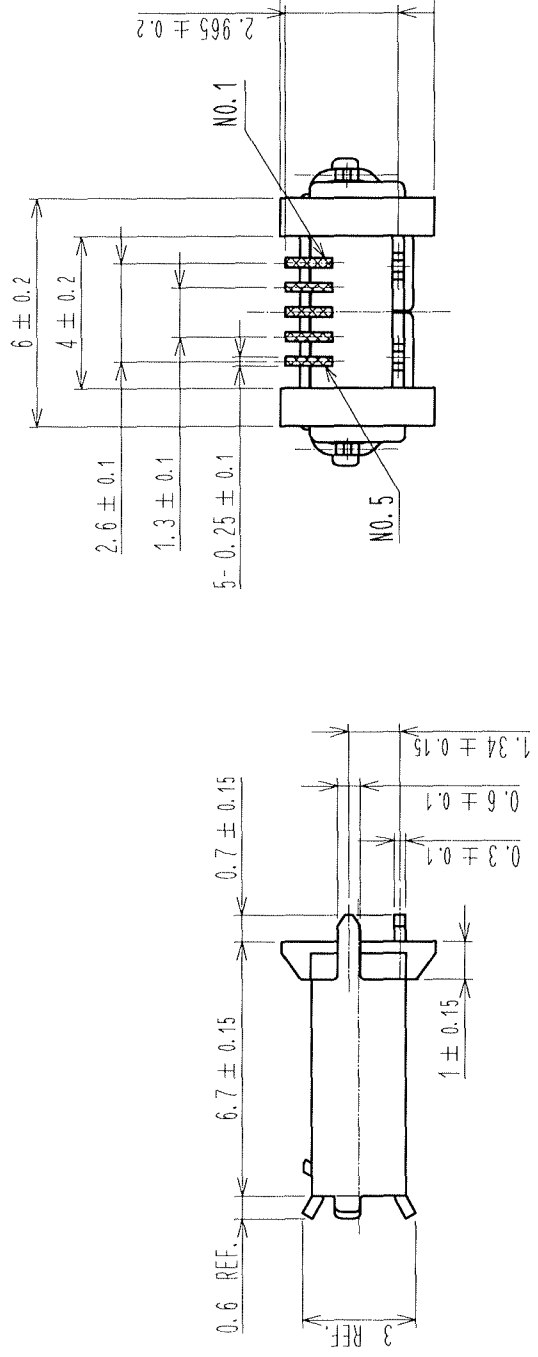
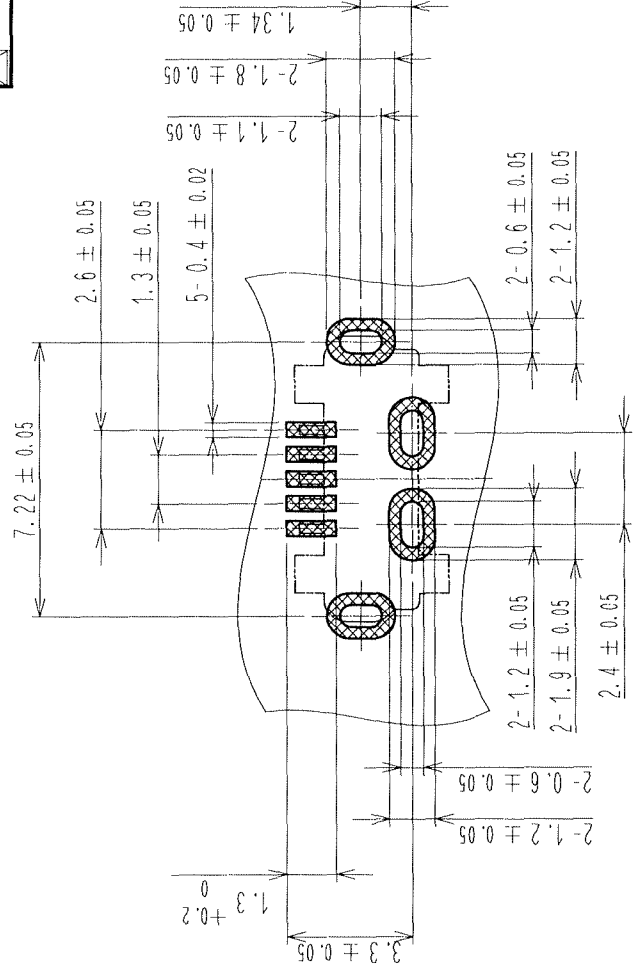

NOTE 1 CO-PLANARITY IS WITHIN 0.08.

2 LOT No. SHALL BE INDICATED AT THE POSITION AS SHOWN.

3 PLATING

CONTACT AREA : GOLD PLATE 0.75 μm MIN.

LEAD AREA : GOLD PLATE 0.05 μm MIN.

UNDER PLATING : NICKEL 2 μm MIN.

4 PACKING

300 PCS PER TRAY.

5 AS FOR PART No.3. THE PERFORMANCE REMAINS GOOD EVEN IF THERE IS A RUBBING WOUND BY THE ASSEMBLY PROCESS. AND THE PERFORMANCE REMAINS GOOD EVEN IF THERE IS A DIFFERENCE OF THE COLOR OF PLATING WITH THE MANUFACTURING LOT.

COUNT	DESCRIPTION OF REVISIONS
1	DIS-E-002592

2	LCP	BLACK
1	COPPER ALLOY	3
NO.	MATERIAL	FINISH, R
CODE NO.(OLD)		
DRAWING NO. EDC3-12		
SCALE	5 : 1	
UNITS	mm	

HRS

HIROSE ELEC

TO			
----	--	--	--

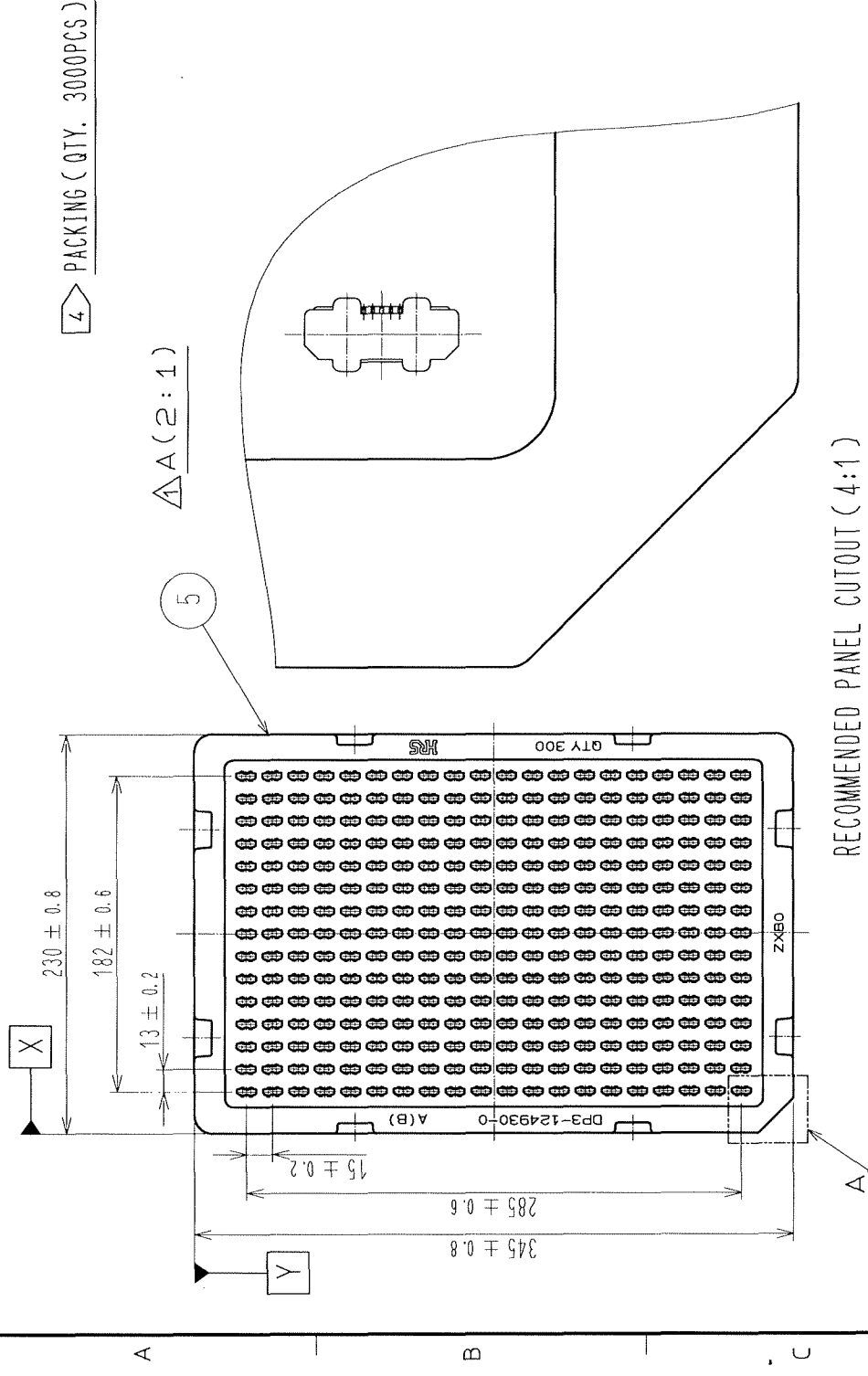

1. STORE CONNECTORS IN A TRAY.

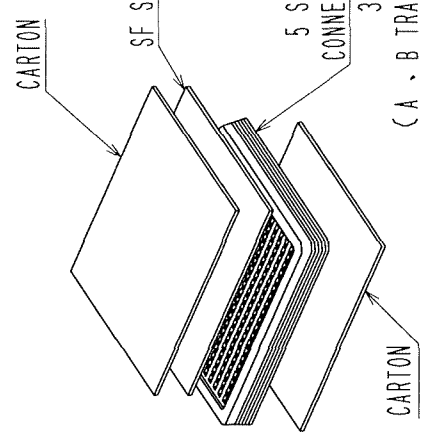

COUNT	DESCRIPTION OF REVISIONS

RECOMMENDED PANEL CUTOUT (4:1)

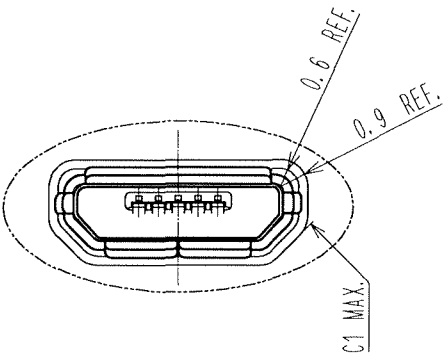
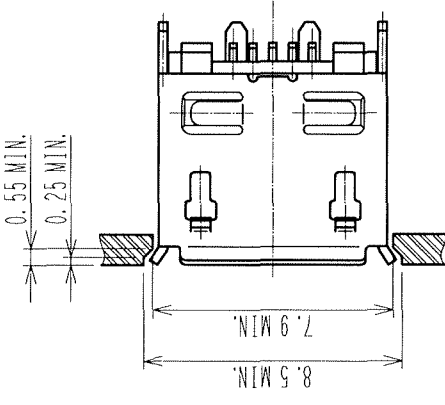

3. STORE 2 (STORE A BOX) THE BOX BY

GUMM

MATED WITH CORRESPONDING PLUG(4:1)

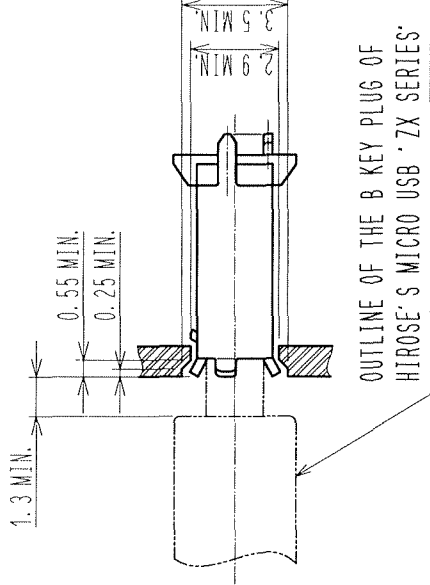

PACKING BOX (CARTON BOX)

NO.	MATERIAL	FINISH, R
CODE NO.(OLD)		
DRAWING NO. EDC3-12		
SCALE	1 : 4	mm
UNITS	mm	
HRS		
HIROSE ELECT		

Looking for pricing, stock, or lifecycle information?

Click below to explore more details on WIN SOURCE:

 [View XM7B-0442 on WIN SOURCE](#)

 [Omron Information](#)

Optimize Your Supply Chain with WIN SOURCE Solutions

-  Global Sourcing Solution
-  Obsolete Management
-  Cost Control Management
-  Shortage Management
-  Alternative Solution
-  Excess Inventory Management