



# THE DATASHEET OF TUSB211AIRWBR



# TUSB211A USB 2.0 480-Mbps High-Speed Signal Conditioner

## 1 Features

- Wide supply voltage range: 2.3 – 6.5 V
- Ultra-low USB disconnect and shutdown power consumption
- Provides USB 2.0 high-speed signal conditioning
- Compatible with USB 2.0, OTG 2.0, and BC 1.2
- Support for low-speed, full-speed, and high-speed signaling
- Host or device agnostic
- Supports up to 5-m cable length
  - Four selectable signal EQ (edge boost along with DC boost) settings through the external pull-down resistor values
- Supports up to 10-m cable length with two TUSB211A devices
- Scalable solution – devices can be daisy chained for high loss applications
- Pin compatible with TUSB211, 212, 214, 216, and 217A (3.3 V)

## 2 Applications

- [Laptop, desktop or docking stations](#)
- [Portable electronics](#)
- [Tablets](#)
- [Cell phones](#)
- [Televisions](#)
- [Active cable, cable extenders, backplane](#)

## 3 Description

The TUSB211A is a third-generation USB 2.0 high-speed signal conditioner designed to compensate both AC loss (due to capacitive load) and DC loss (due to resistive loss) in the transmission channel.

The TUSB211A leverages a patented design to speed-up transition edges of USB 2.0 high-speed signal with an edge booster and increases static levels with a DC boost function.

In addition, the TUSB211A includes a pre-equalization function to compensate the inter-symbol interference (ISI) jitter in application with longer cable length. USB low-speed and full-speed signal characteristics are unaffected by the TUSB211A.

The TUSB211A improves signal quality without altering packet timing or adding propagation delay or latency.

The TUSB211A helps a system to pass the USB 2.0 high-speed near end eye compliance with a cable as long as 5 meters.

The TUSB211A is compatible with USB On-The-Go (OTG) and Battery Charging (BC) protocols.

### Device Information

PART NUMBER	PACKAGE <sup>(1)</sup>	OP TEMP (T <sub>A</sub> ) °C	BODY SIZE (NOM) <sup>(2)</sup>
TUSB211A	RWB	0 to 70	1.6 mm × 1.6 mm
TUSB211AI	(X2QFN, 12)	-40 to 85	

(1) For all available packages, see the orderable addendum at the end of the data sheet.

(2) The body size (length × width) is a nominal value and does not include pins.

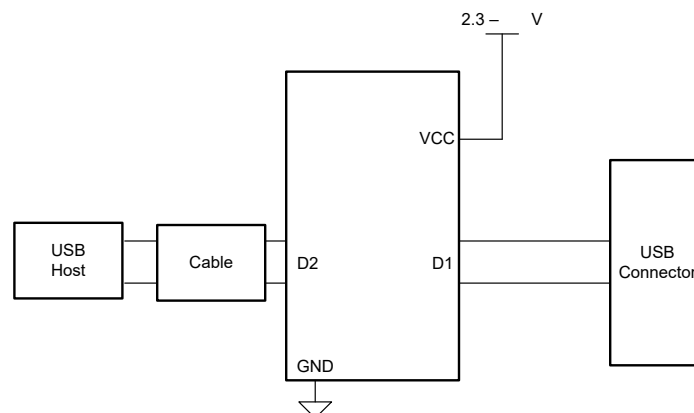

**Simplified Schematic**



## Table of Contents

<b>1 Features</b> .....	1	7.2 Functional Block Diagram.....	7
<b>2 Applications</b> .....	1	7.3 Feature Description.....	7
<b>3 Description</b> .....	1	7.4 Device Functional Modes.....	7
<b>4 Revision History</b> .....	2	<b>8 Application and Implementation</b> .....	9
<b>5 Pin Configuration and Functions</b> .....	3	8.1 Application Information.....	9
<b>6 Specifications</b> .....	4	8.2 Typical Application.....	9
6.1 Absolute Maximum Ratings.....	4	8.3 Power Supply Recommendations.....	15
6.2 ESD Ratings.....	4	8.4 Layout.....	15
6.3 Recommended Operating Conditions.....	4	<b>9 Device and Documentation Support</b> .....	17
6.4 Thermal Information.....	4	9.1 Receiving Notification of Documentation Updates....	17
6.5 Electrical Characteristics.....	5	9.2 Support Resources.....	17
6.6 Switching Characteristics.....	5	9.3 Trademarks.....	17
6.7 Timing Requirements.....	6	9.4 Electrostatic Discharge Caution.....	17
6.8 Typical Characteristics.....	6	9.5 Glossary.....	17
<b>7 Detailed Description</b> .....	7	<b>10 Mechanical, Packaging, and Orderable Information</b> .....	17
7.1 Overview.....	7		

## 4 Revision History

DATE	REVISION	NOTES
September 2023	*	Initial Release

## 5 Pin Configuration and Functions

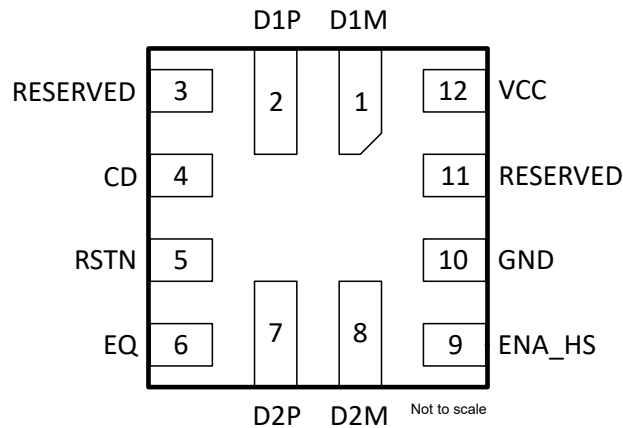

**Figure 5-1. TUSB211A RWB 12-Pin X2QFN (Top View)**

**Table 5-1. Pin Functions**

PIN		TYPE <sup>(1)</sup>	INTERNAL PULLUP/PULLDOWN	DESCRIPTION
NAME	NO.			
EQ	6	I	N/A	USB High-speed EQ select via external pull down resistor. Both edge boost and DC boost are controlled by a single pin. Sampled upon power up. Does not recognize real time adjustments. Auto selects EQ LEVEL = 3 when left floating.
RESERVED	11	I	500 kΩ PU	Reserved pin for TI test purposes. Leave floating or connect external capacitor to GND for normal operation.
ENA_HS	9	I/O	N/A	After reset: Output signal ENA_HS. Flag indicating that channel is in High-speed mode. Asserted upon: 1. Detection of USB-IF High-speed test fixture from an unconnected state followed by transmission of USB TEST_PACKET pattern. 2. Squelch detection following USB reset with a successful HS handshake [HS handshake is declared to be successful after single chirp J chirp K pair where each chirp is within 18 μs – 128 μs].
D2P	7	I/O	N/A	USB High-speed positive port.
D2M	8	I/O	N/A	USB High-speed negative port.
GND	10	P	N/A	Ground
D1M	1	I/O	N/A	USB High-speed negative port.
D1P	2	I/O	N/A	USB High-speed positive port.
RESERVED	3	I/O	500 kΩ PU 1.8 MΩ PD	Reserved pin for TI test purposes. Leave floating for normal operation.
VCC	12	P	N/A	Supply power
RSTN	5	I	500 kΩ PU 1.8 MΩ PD	Device disable/enable. Low – Device is at reset and in shutdown, and High - Normal operation. Recommend 0.1-μF external capacitor to GND to ensure clean power on reset if not driven. If the pin is driven, it must be held low until the supply voltage for the device reaches within specifications.
CD	4	O	When RSTN asserted there is a 500 kΩ PD	After reset: Output CD. Flag indicating that a USB device is attached (connection detected). Asserted from an unconnected state upon detection of DP or DM pull-up resistor. De-asserted upon detection of disconnect.

(1) I = input, O = output, P = power

## 6 Specifications

### 6.1 Absolute Maximum Ratings

Over operating free-air temperature range (unless otherwise noted) <sup>(1)</sup>

		MIN	MAX	UNIT
Supply voltage range	VCC	-0.3	7	V
Voltage range USB data	DxP, DxM	-0.3	5.5	V
Voltage range on EQ pin	EQ	-0.3	1.98	V
Voltage range other pins	RSTN	-0.3	5.5	V
Storage temperature, T <sub>stg</sub>		-65	150	°C
Maximum junction temperature, T <sub>J(max)</sub>			125	°C

- (1) Operation outside the *Absolute Maximum Rating* may cause permanent device damage. *Absolute Maximum Rating* do not imply functional operation of the device at these or any other conditions beyond those listed under *Recommended Operating Condition*. If used outside the *Recommended Operating Condition* but within the *Absolute Maximum Rating*, the device may not be fully functional, and this may affect device reliability, functionality, performance, and shorten the device lifetime.

### 6.2 ESD Ratings

			VALUE	UNIT
V <sub>(ESD)</sub>	Electrostatic discharge	Human-body model (HBM), per ANSI/ESDA/JEDEC JS-001 <sup>(2)</sup>	±2000	V
		Charged-device model (CDM), per ANSI/ESDA/JEDEC JS-002 <sup>(3)</sup>	±750	

- (1) JEDEC document JEP155 states that 500-V HBM allows safe manufacturing with a standard ESD control process.  
 (2) JEDEC document JEP157 states that 250-V CDM allows safe manufacturing with a standard ESD control process.

### 6.3 Recommended Operating Conditions

over operating free-air temperature range (unless otherwise noted)

		MIN	NOM	MAX	UNIT
V <sub>CC</sub>	Supply voltage	2.3	5	6.5	V
T <sub>A</sub>	Operating free-air temperature (TUSB211A)	0		70	°C
	Operating free-air temperature (TUSB211AI)	-40		85	°C
T <sub>J</sub>	Junction temperature (TUSB211A)			85	°C
	Junction temperature (TUSB211AI)			105	°C
DxP, DxM	Voltage range USB data	0		3.6	V
EQ	Voltage range EQ pin	0		1.98	V
DIGITAL	Voltage range other pins (RSTN)	0		3.6	V

### 6.4 Thermal Information

THERMAL METRIC <sup>(1)</sup>		RWB (X2QFN)	UNIT
		12 PINS	
R <sub>θJA</sub>	Junction-to-ambient thermal resistance	137.4	°C/W
R <sub>θJC(top)</sub>	Junction-to-case (top) thermal resistance	62	°C/W
R <sub>θJB</sub>	Junction-to-board thermal resistance	67.2	°C/W
Ψ <sub>JT</sub>	Junction-to-top characterization parameter	1.9	°C/W
Ψ <sub>JB</sub>	Junction-to-board characterization parameter	67.3	°C/W
R <sub>θJC(bot)</sub>	Junction-to-case (bottom) thermal resistance	N/A	°C/W

- (1) For more information about traditional and new thermal metrics, see the *Semiconductor and IC Package Thermal Metrics* application report, [SPRA953](#).

## 6.5 Electrical Characteristics

Over operating free-air temperature range (unless otherwise noted)

PARAMETER		TEST CONDITIONS	MIN	TYP <sup>(1)</sup>	MAX	UNIT
<b>POWER</b>						
I <sub>ACTIVE_HS</sub>	High Speed Active Current	USB channel = HS mode. 480 Mbps traffic. V <sub>CC</sub> supply stable, with EQ = Max		22	36	mA
I <sub>IDLE_HS</sub>	High Speed Idle Current	USB channel = HS mode, no traffic. V <sub>CC</sub> supply stable, EQ = Max		22	36	mA
I <sub>HS_SUSPEND</sub>	High Speed Suspend Current	USB channel = HS Suspend mode. V <sub>CC</sub> supply stable		0.75	1.4	mA
I <sub>FS</sub>	Full-Speed Current	USB channel = FS mode, 12 Mbps traffic, V <sub>CC</sub> supply stable		0.75	1.4	mA
I <sub>DISCONN</sub>	Disconnect Power	Host side application. No device attachment.		0.80	1.4	mA
I <sub>SHUTDN</sub>	Shutdown Power	RSTN driven low, V <sub>CC</sub> supply stable		60	115	μA
<b>CONTROL PIN LEAKAGE</b>						
I <sub>LKG_FS</sub>	Pin failsafe leakage current for RSTN	V <sub>CC</sub> = 0 V, pin at V <sub>IH,max</sub>		10	15	μA
<b>INPUT RSTN</b>						
V <sub>IH</sub>	High level input voltage		1.5		3.6	V
V <sub>IL</sub>	Low-level input voltage		0		0.5	V
I <sub>IH</sub>	High level input current	V <sub>IH</sub> = 3.6 V, R <sub>PU</sub> enabled			±15	μA
I <sub>IL</sub>	Low level input current	V <sub>IL</sub> = 0V, R <sub>PU</sub> enabled			±20	μA
<b>INPUT EQ</b>						
R <sub>EQ_LVL0</sub>	External pulldown resistor for EQ Level 0				160	Ω
R <sub>EQ_LVL1</sub>	External pulldown resistor for EQ Level 1		1.5	1.8	2	kΩ
R <sub>EQ_LVL2</sub>	External pulldown resistor for EQ Level 2		3.4	3.6	3.96	kΩ
R <sub>EQ_LVL3</sub>	External pulldown resistor for EQ Level 3 to remove upper limit for resistor value, can be left open		7.5			kΩ
<b>OUTPUTS CD, ENA_HS</b>						
V <sub>OH</sub>	High level output voltage for CD and ENA_HS	I <sub>O</sub> = -50 μA, V <sub>CC</sub> ≥ 3.0 V	2.5			V
V <sub>OH</sub>	High level output voltage for CD	I <sub>O</sub> = -25 μA, V <sub>CC</sub> = 2.3 V	1.7			V
V <sub>OH</sub>	High level output voltage for ENA_HS	I <sub>O</sub> = -25 μA, V <sub>CC</sub> = 2.3 V	1.8			V
V <sub>OL</sub>	Low level output voltage for CD and ENA_HS	I <sub>O</sub> = 50 μA			0.3	V
<b>DxP, DxM</b>						
C <sub>IO_DXX</sub>	Capacitance to GND	Measured with VNA at 240 MHz, V <sub>CC</sub> supply stable, Redriver off		2.5		pF

(1) All typical values are at V<sub>CC</sub> = 5 V, and T<sub>A</sub> = 25°C.

## 6.6 Switching Characteristics

Over operating free-air temperature range (unless otherwise noted)

PARAMETER		TEST CONDITIONS	MIN	TYP <sup>(1)</sup>	MAX	UNIT
<b>DxP, DxM USB Signals</b>						
F <sub>BR_DXX</sub>	Bit Rate	USB channel = HS mode. 480 Mbps traffic. V <sub>CC</sub> supply stable			480	Mbps
t <sub>R/F_DXX</sub>	Rise/Fall time		100			ps

(1) All typical values are at V<sub>CC</sub> = 5 V, and T<sub>A</sub> = 25°C.

## 6.7 Timing Requirements

		MIN	NOM	MAX	UNIT
<b>POWER UP TIMING</b>					
$T_{RSTN\_PW}$	Minimum width to detect a valid RSTN signal assert when the pin is actively driven low	100			$\mu\text{s}$
$T_{STABLE}$	VCC must be stable before RSTN de-assertion	300			$\mu\text{s}$
$T_{READY}$	Maximum time needed for the device to be ready after RSTN is de-asserted.			500	$\mu\text{s}$
$T_{RAMP}$	$V_{CC}$ ramp time			100	ms
$T_{RAMP}$	$V_{CC}$ ramp time	0.2			ms

## 6.8 Typical Characteristics

The typical characteristics shown in this section apply to near-end eye measurements taken at nominal conditions. The eyes are measured with various pre-channel cable lengths applied at the input or post-channel cable lengths applied at the output of the TUSB211A as indicated.

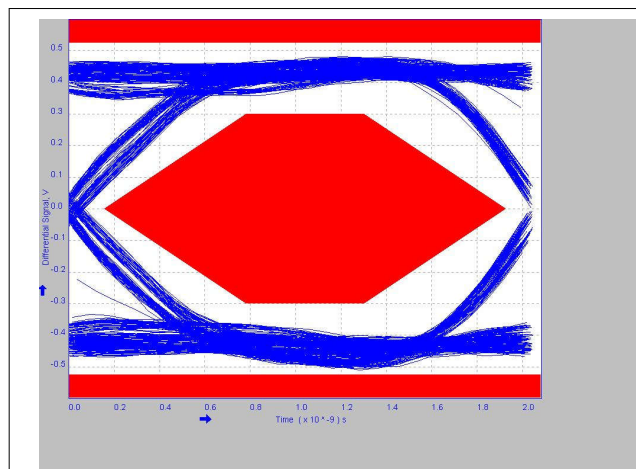

Figure 6-1. 2 Meter Pre-Channel With TUSB211A EQ=1

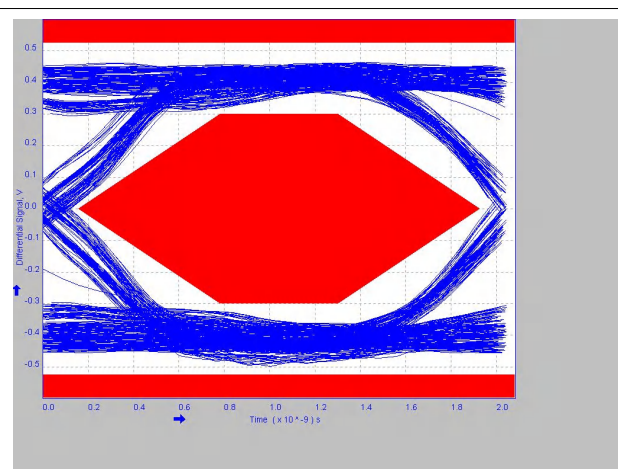

Figure 6-2. 5 Meter Pre-Channel With TUSB211A EQ=2

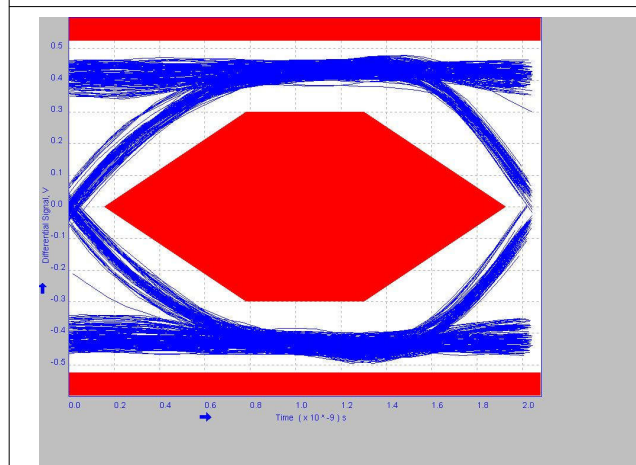

Figure 6-3. 2 Meter Post-Channel With TUSB211A EQ=1

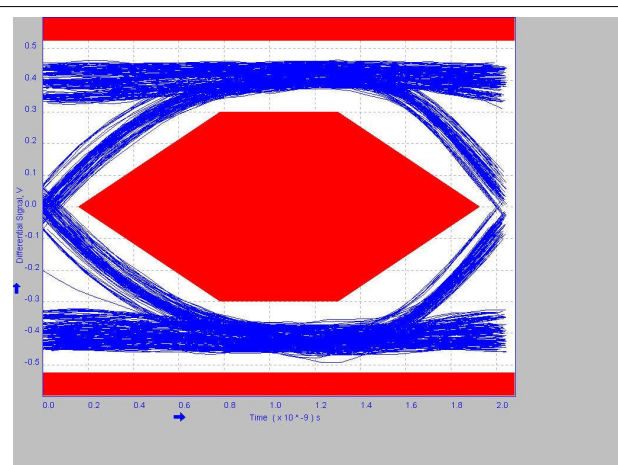

Figure 6-4. 4 Meter Post-Channel With TUSB211A EQ=2

## 7 Detailed Description

### 7.1 Overview

The TUSB211A is a USB High-Speed (HS) signal conditioner designed to compensate for ISI signal loss in a transmission channel. TUSB211A has a patented design for USB Low Speed (LS) and Full Speed (FS) signals. It does not alter the signal characteristics. HS signals are compensated. The design is compatible with USB On-The-Go (OTG) and Battery Charging (BC) specifications.

Programmable signal gain through an external resistor permits fine tuning device performance to optimize signals. This helps pass USB HS electrical compliance tests at the connector. The TUSB211A allows application in series to cover longer distances, or high loss transmission paths. A maximum of 4 devices can be daisy-chained.

### 7.2 Functional Block Diagram

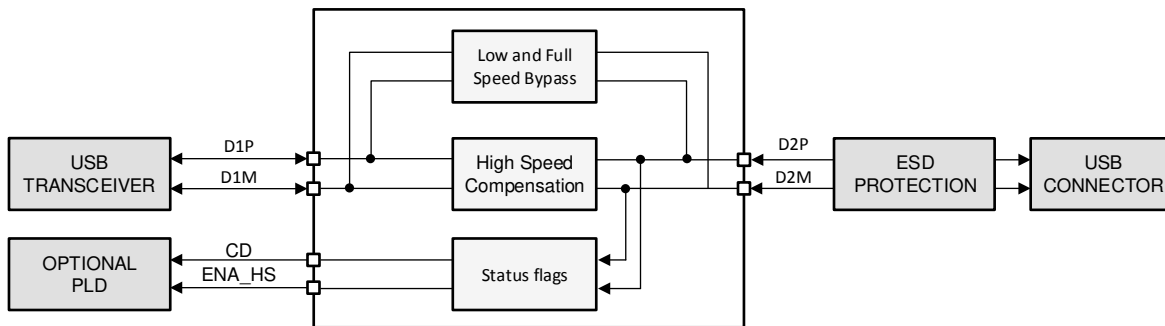

Copyright © 2018, Texas Instruments Incorporated

### 7.3 Feature Description

#### 7.3.1 High-Speed EQ

The high-speed EQ (combination of edge boost and DC boost) improves the eye width for USB2.0 high-speed signals. It is direction independent and by that is compatible to OTG systems. The EQ pin is configuring the EQ strength with different values of pull down resistors to set 4 levels of EQ.

### 7.4 Device Functional Modes

#### 7.4.1 Low-Speed (LS) Mode

TUSB211A automatically detects an LS connection and does not enable signal compensation. CD pin is asserted high but ENA\_HS will be low.

#### 7.4.2 Full-Speed (FS) Mode

TUSB211A automatically detects an FS connection and does not enable signal compensation. CD pin is asserted high but ENA\_HS will be low.

#### 7.4.3 High-Speed (HS) Mode

TUSB211A automatically detects an HS connection and will enable signal compensation as determined by the external pull down resistance on its EQ pin.

CD pin and ENA\_HS pin are asserted high when high-speed EQ is active.

#### 7.4.4 High-Speed Downstream Port Electrical Compliance Test Mode

TUSB211A will detect an HS compliance test fixture and enter the downstream port high-speed eye diagram test mode. CD pin will be low and ENA\_HS pin is asserted high when TUSB211A is in HS eye compliance test mode.

If the RSTN pin is asserted low and de-asserted high while TUSB211A is operating in HS functional mode, then TUSB211A will transition to HS eye compliance test mode, the CD asserts low, and ENA\_HS remains high. When all this occurs, signal compensation is enabled.

### 7.4.5 Shutdown Mode

TUSB211A can be disabled when its RSTN pin is asserted low. DP, DM traces are continuous through the device in shutdown mode. The USB channel is still fully operational, but there is neither signal compensation, nor any indication from the CD pin as to the status of the channel.

**Table 7-1. CD and ENA\_HS Pins in Different Modes**

MODE	CD	ENA_HS
Low-speed	HIGH	LOW
Full-speed	HIGH	LOW
High-speed	HIGH	HIGH
High-speed downstream port electrical test	LOW	HIGH
Shutdown	LOW	LOW

## 8 Application and Implementation

### Note

Information in the following applications sections is not part of the TI component specification, and TI does not warrant its accuracy or completeness. TI's customers are responsible for determining suitability of components for their purposes, as well as validating and testing their design implementation to confirm system functionality.

### 8.1 Application Information

The purpose of the TUSB211A is to restore the signal integrity of a USB High-speed channel up to the USB connector. The loss in signal quality stems from reduced channel bandwidth due to high loss PCB trace and other components that contribute a capacitive load. This can cause the channel to fail the USB near end eye mask. Proper use of the TUSB211A can help to pass this eye mask.

A secondary purpose is to use the CD pin of the TUSB211A to control other blocks on the customer platform, if so desired.

### 8.2 Typical Application

A typical application for TUSB211A is shown in [Figure 8-1](#). In this setup, D2P and D2M face the USB connector while D1P and D1M face the USB host. The orientation may be reversed [that is, D2 faces transceiver and D1 faces connector].

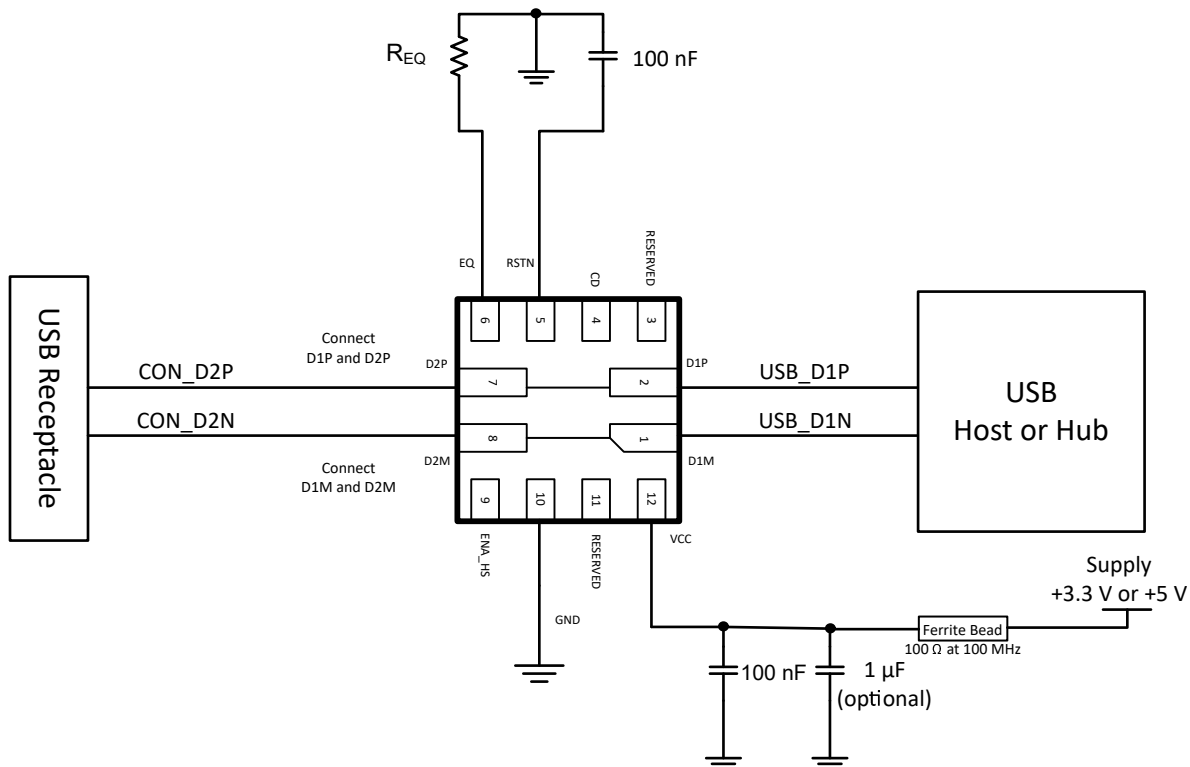

Copyright © 2023, Texas Instruments Incorporated

**Figure 8-1. TUSB211A Reference Schematic**

### 8.2.1 Design Requirements

TUSB211A requires a valid reset signal as described in the *Power Supply Recommendations* section. The capacitor at RSTN pin is not required if a micro controller drives the RSTN pin according to recommendations.

For this design example, use the parameters provided in [Table 8-1](#).

**Table 8-1. Design Parameters for 3.3-V Supply With Low to Medium Loss System**

PARAMETER			VALUE <sup>(1)</sup>
V <sub>CC</sub>			3.3 V ±10%
I <sup>2</sup> C support required in system (Yes/No)			No
Edge and DC Boost	<b>R<sub>EQ</sub></b>	<b>EQ Level</b>	EQ Level 0: R <sub>EQ</sub> = 0-Ω
	0-Ω	0	
	1.8 kΩ ±1%	1	
	3.6 kΩ ±1%	2	
	Do Not Install (DNI)	3	

(1) These parameters are starting values for a low to medium loss system. Further tuning might be required based on specific host or device as well as cable length and loss profile. These settings are not specific to a 3.3-V supply system and could be applicable to 5-V supply system as well.

### 8.2.2 Detailed Design Procedure

The ideal EQ setting is dependent upon the signal chain loss characteristics of the target platform. The recommendation is to start with EQ Level 0, and then increment to EQ Level 1, and so on.

For the TUSB211A to recognize any change to the EQ setting, the RSTN pin must be toggled. This is because the EQ pin is latched on power up and the pin is ignored thereafter.

Placement of the device is also dependent on the application goal. [Table 8-2](#) describes TI recommendations.

**Table 8-2. Platform Placement Guideline**

PLATFORM GOAL	SUGGESTED TUSB211A PLACEMENT
Pass USB Near End Mask at the receptacle	Close to measurement point (connector)
Pass USB Far End Eye Mask at the plug	Close to USB PHY
Cascade multiple TUSB211As to improve device enumeration	Midway between each USB interconnect

**Table 8-3. Table of Recommended Settings**

EQ settings <sup>(1)</sup> for channel loss		
Pre-channel cable length (Between USB PHY and TUSB211A)	EQ	
0-3 meter	Level 0	
2-5 meter	Level 1	
Post-channel cable length (Between TUSB211A and inter-connect)	EQ	
0-2 meter	Level 0	
1-4 meter	Level 1	

(1) These parameters are starting values for different cable lengths. Further tuning might be required based on specific host or device as well as cable length and loss profile.

#### 8.2.2.1 Test Procedure to Construct USB High-Speed Eye Diagram

##### Note

USB-IF certification tests for High-speed eye masks require the *mandated use* of the USB-IF developed test fixtures. These test fixtures do not require the use of oscilloscope probes. Instead they use SMA cables. More information can be found at the USB-IF Compliance Updates Page. It is located under the *Electrical Specifications* section, ID 86 dated March 2013.

The following procedure must be followed before using any oscilloscope compliance software to construct a USB High-speed Eye Mask:

#### **8.2.2.1.1 For a Host Side Application**

1. Configure the TUSB211A to the desired EQ setting.
2. Power on (or toggle the RSTN pin if already powered on) the TUSB211A.
3. Using SMA cables, connect the oscilloscope and the USB-IF host-side test fixture to the TUSB211A.
4. Enable the host to transmit USB TEST\_PACKET.
5. Execute the oscilloscope USB compliance software.
6. Repeat the above steps to re-test TUSB211A with a different EQ setting (must reset to change).

#### **8.2.2.1.2 For a Device Side Application**

1. Configure the TUSB211A to the desired EQ setting.
2. Power on (or toggle the RSTN pin if already powered on) the TUSB211A.
3. Connect a USB host, the USB-IF device-side test fixture, and USB device to the TUSB211A. Ensure that the USB-IF device test fixture is configured to the 'INIT' position.
4. Allow the host to enumerate the device.
5. Enable the device to transmit USB TEST\_PACKET.
6. Using SMA cables, connect the oscilloscope to the USB-IF device-side test fixture and ensure that the device-side test fixture is configured to the 'TEST' position.
7. Execute the oscilloscope USB compliance software.
8. Repeat the above steps to re-test TUSB211A with a different EQ setting (must reset to change).

### 8.2.3 Application Curves

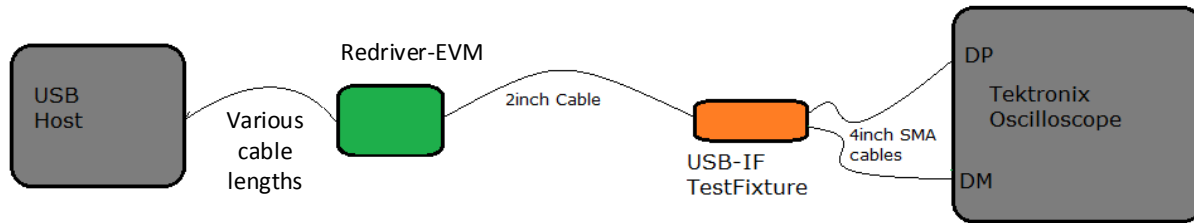

Figure 8-2. Near End Eye Measurement Set-Up With Pre-Channel Cable

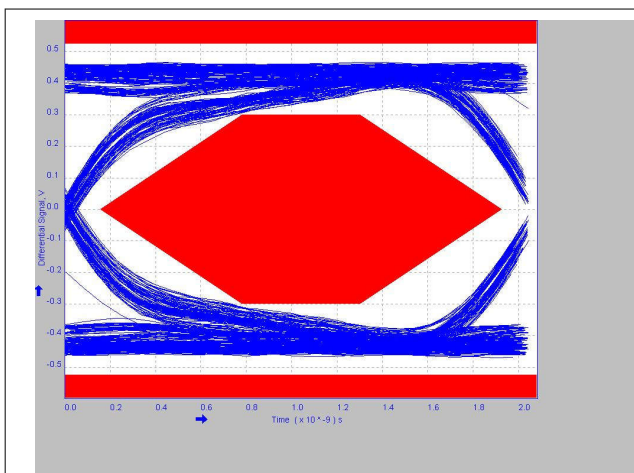

Figure 8-3. 2 Meter Pre-Channel Without TUSB211A

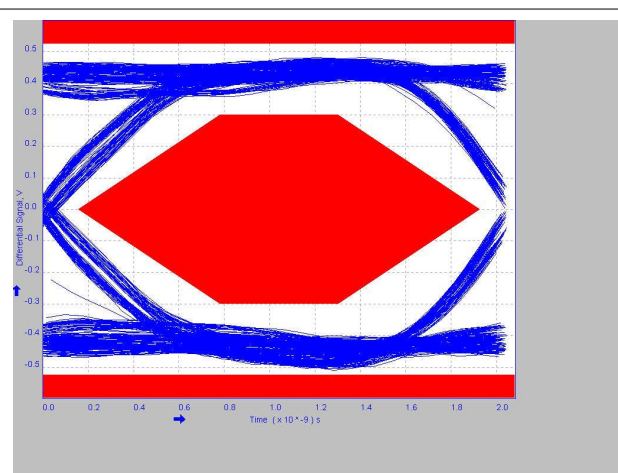

Figure 8-4. 2 Meter Pre-Channel With TUSB211A EQ=1

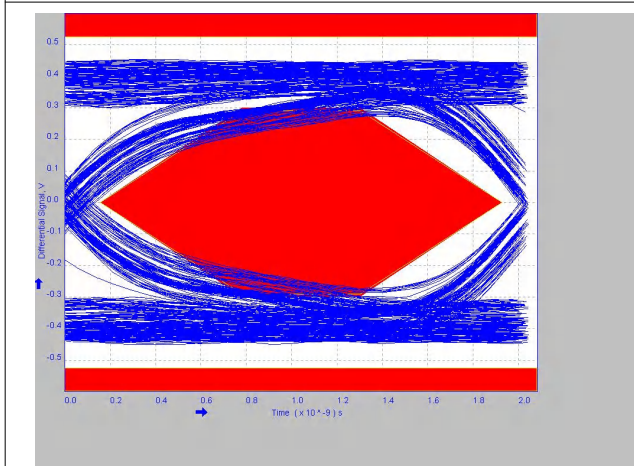

Figure 8-5. 5 Meter Without TUSB211A

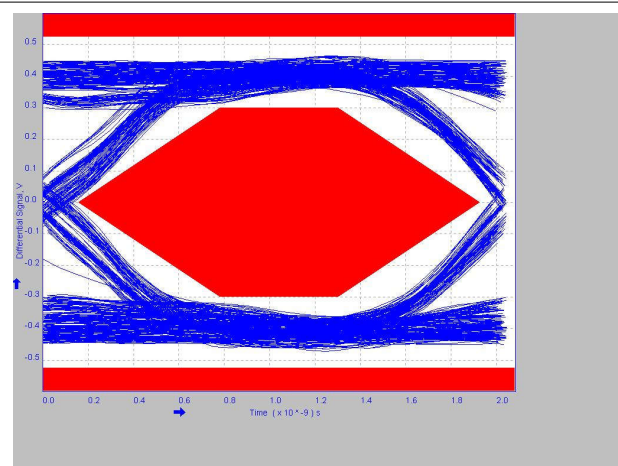
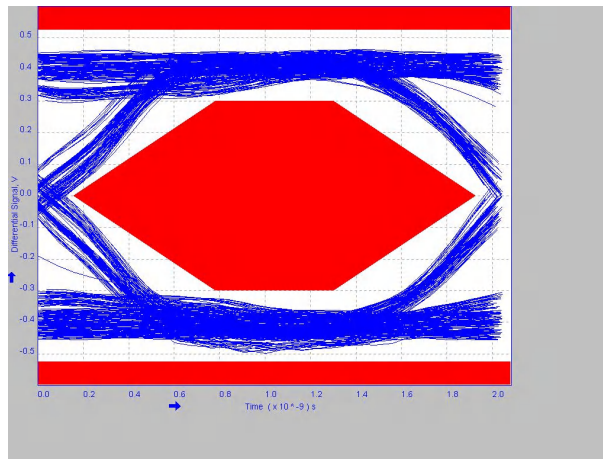

Figure 8-6. 5 Meter Pre-Channel With TUSB211A EQ=1

### 8.2.3 Application Curves (continued)



**Figure 8-7. 5 Meter Pre-Channel With TUSB211A EQ=2**

### 8.2.3 Application Curves

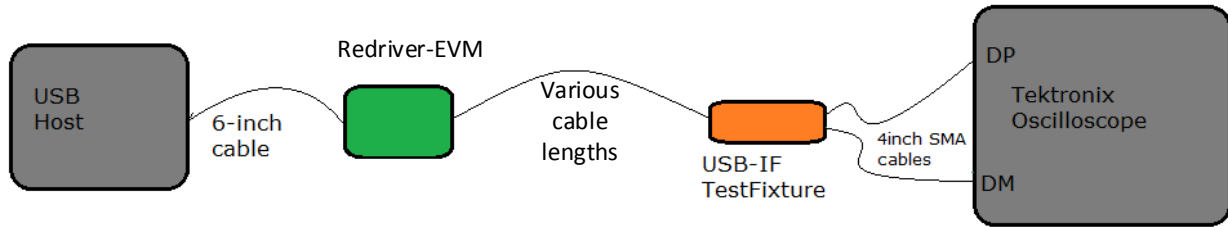

Figure 8-8. Near End Eye Measurement Set-Up With Post-Channel Cable

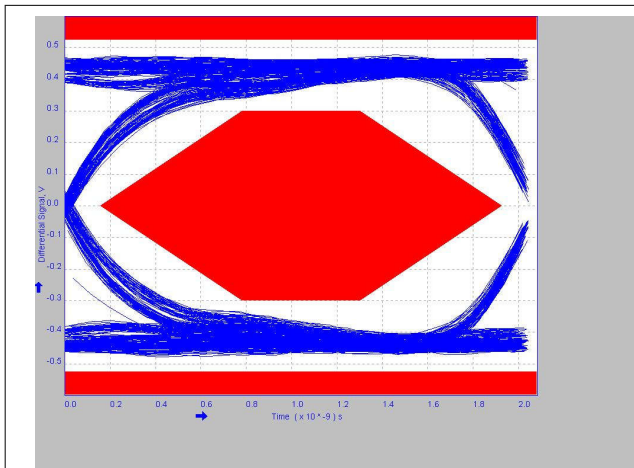

Figure 8-9. 1 Meter Post-Channel Without TUSB211A

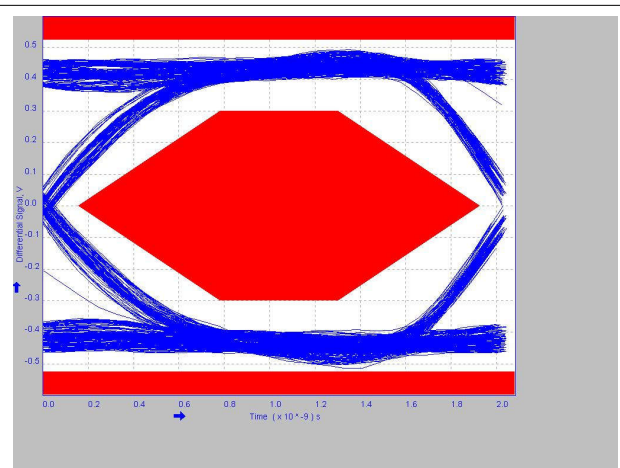

Figure 8-10. 1 Meter Post-Channel With TUSB211A EQ=0

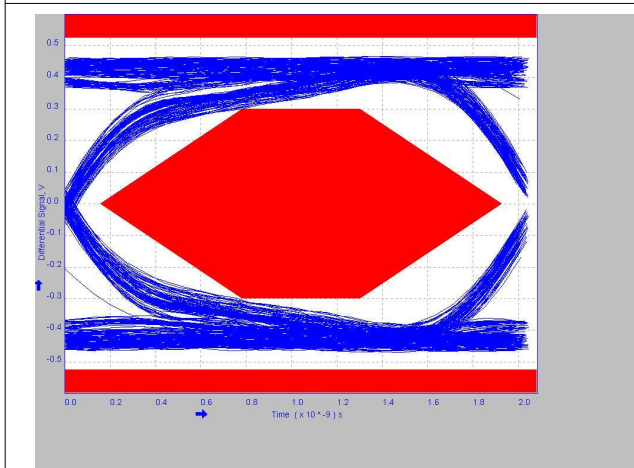

Figure 8-11. 2 Meter Post-Channel Without TUSB211A

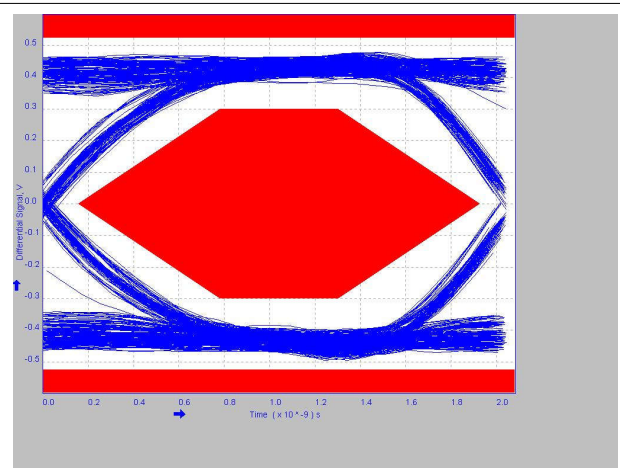

Figure 8-12. 2 Meter Post-Channel With TUSB211A EQ=1

### 8.2.3 Application Curves (continued)

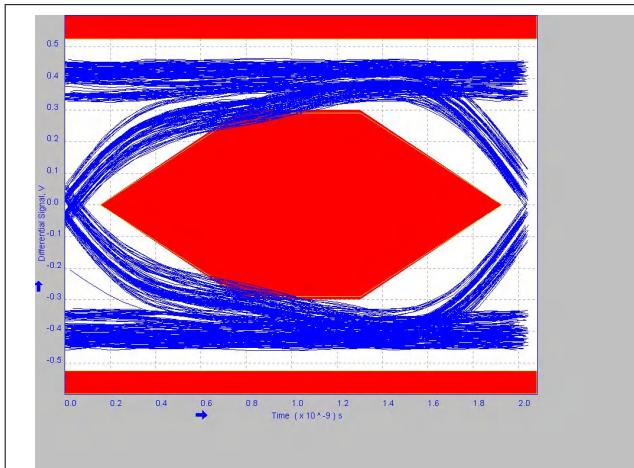

Figure 8-13. 4 Meter Post-Channel Without TUSB211A

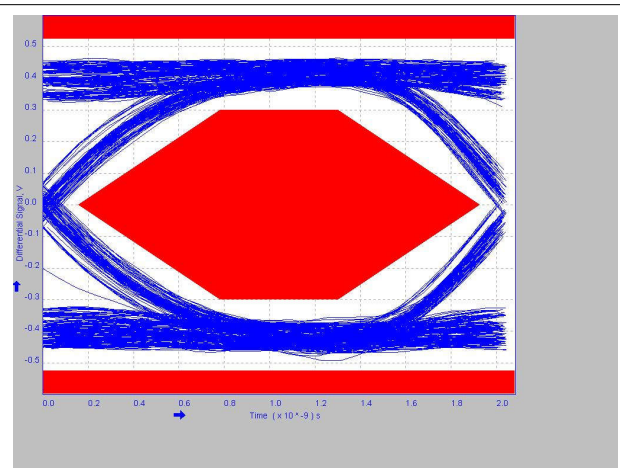

Figure 8-14. 4 Meter Post-Channel With TUSB211A EQ=2

## 8.3 Power Supply Recommendations

On power up, the interaction of the RSTN pin and power on ramp could result in digital circuits not being set correctly. The device should not be enabled until the power on ramp has settled to the minimum recommended supply voltage or higher for a correct power on reset of the digital circuitry. If RSTN cannot be held low by microcontroller or other circuitry until the power on ramp has settled, then an external capacitor from the RSTN pin to GND is required to hold the device in the low power reset state.

The RC time constant should be larger than five times of the power on ramp time (0 to  $V_{CC}$ ). With a typical internal pullup resistance of 500 k $\Omega$ , the recommended minimum external capacitance is calculated as:

$$[Ramp\ Time \times 5] \div [500\ k\Omega] \tag{1}$$

## 8.4 Layout

### 8.4.1 Layout Guidelines

Although the land pattern has matched trace width to pad width, optimal impedance control is based on the user's own PCB stack-up. The recommendation is to maintain 90  $\Omega$  differential routing underneath the device.

### 8.4.2 Layout Example

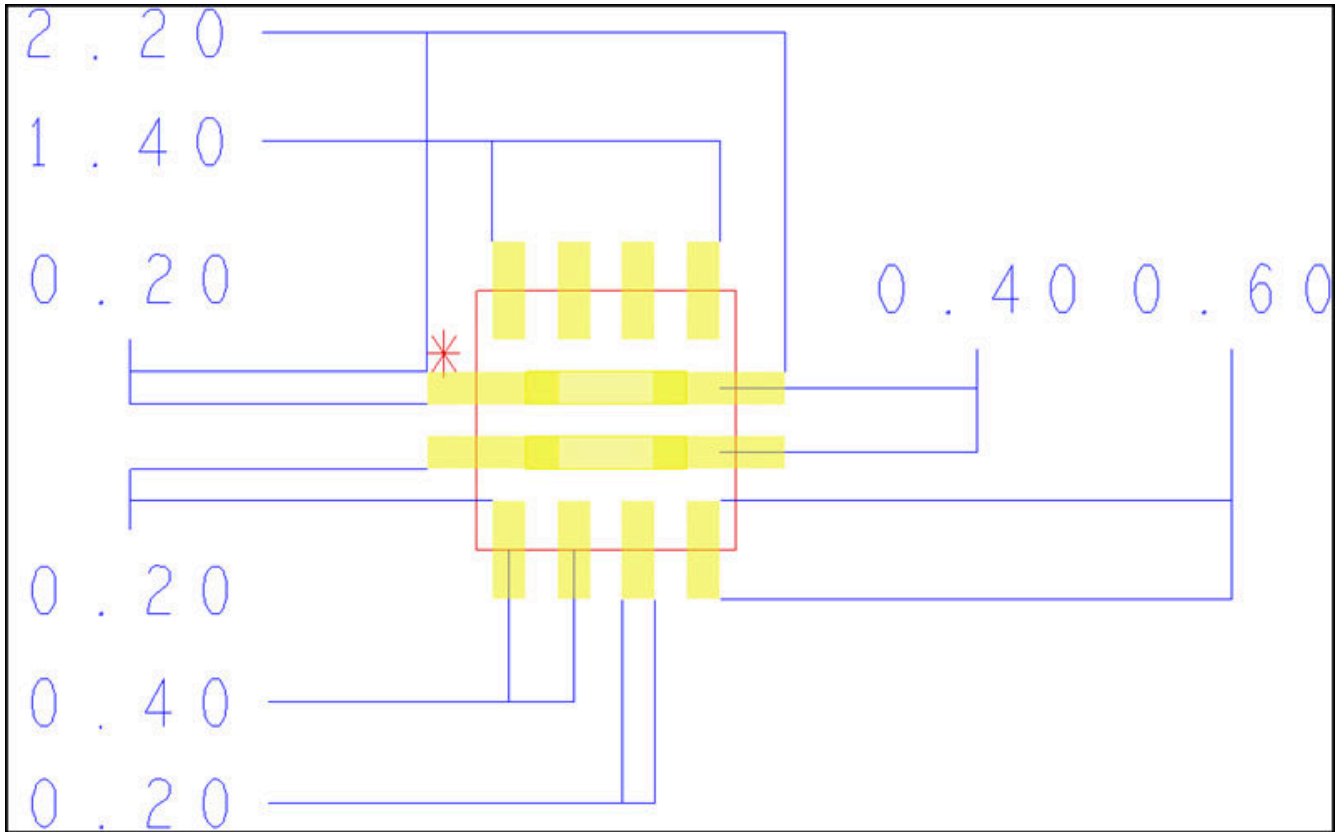

Figure 8-15. DP and DM Routing Underneath Device Package

## 9 Device and Documentation Support

### 9.1 Receiving Notification of Documentation Updates

To receive notification of documentation updates, navigate to the device product folder on [ti.com](https://www.ti.com). Click on *Subscribe to updates* to register and receive a weekly digest of any product information that has changed. For change details, review the revision history included in any revised document.

### 9.2 Support Resources

[TI E2E™ support forums](#) are an engineer's go-to source for fast, verified answers and design help — straight from the experts. Search existing answers or ask your own question to get the quick design help you need.

Linked content is provided "AS IS" by the respective contributors. They do not constitute TI specifications and do not necessarily reflect TI's views; see TI's [Terms of Use](#).

### 9.3 Trademarks

TI E2E™ is a trademark of Texas Instruments.  
All trademarks are the property of their respective owners.

### 9.4 Electrostatic Discharge Caution



This integrated circuit can be damaged by ESD. Texas Instruments recommends that all integrated circuits be handled with appropriate precautions. Failure to observe proper handling and installation procedures can cause damage.

ESD damage can range from subtle performance degradation to complete device failure. Precision integrated circuits may be more susceptible to damage because very small parametric changes could cause the device not to meet its published specifications.

### 9.5 Glossary

[TI Glossary](#) This glossary lists and explains terms, acronyms, and definitions.

## 10 Mechanical, Packaging, and Orderable Information

The following pages include mechanical, packaging, and orderable information. This information is the most current data available for the designated devices. This data is subject to change without notice and revision of this document. For browser-based versions of this data sheet, refer to the left-hand navigation.

## PACKAGING INFORMATION

Orderable part number	Status (1)	Material type (2)	Package   Pins	Package qty   Carrier	RoHS (3)	Lead finish/ Ball material (4)	MSL rating/ Peak reflow (5)	Op temp (°C)	Part marking (6)
<a href="#">TUSB211AIRWBR</a>	Active	Production	X2QFN (RWB)   12	3000   LARGE T&R	Yes	NIPDAU	Level-2-260C-1 YEAR	-40 to 85	1A
TUSB211AIRWBR.A	Active	Production	X2QFN (RWB)   12	3000   LARGE T&R	Yes	NIPDAU	Level-2-260C-1 YEAR	-40 to 85	1A
<a href="#">TUSB211ARWBR</a>	Active	Production	X2QFN (RWB)   12	3000   LARGE T&R	Yes	NIPDAU	Level-2-260C-1 YEAR	0 to 70	1A
TUSB211ARWBR.A	Active	Production	X2QFN (RWB)   12	3000   LARGE T&R	Yes	NIPDAU	Level-2-260C-1 YEAR	0 to 70	1A

(1) **Status:** For more details on status, see our [product life cycle](#).

(2) **Material type:** When designated, preproduction parts are prototypes/experimental devices, and are not yet approved or released for full production. Testing and final process, including without limitation quality assurance, reliability performance testing, and/or process qualification, may not yet be complete, and this item is subject to further changes or possible discontinuation. If available for ordering, purchases will be subject to an additional waiver at checkout, and are intended for early internal evaluation purposes only. These items are sold without warranties of any kind.

(3) **RoHS values:** Yes, No, RoHS Exempt. See the [TI RoHS Statement](#) for additional information and value definition.

(4) **Lead finish/Ball material:** Parts may have multiple material finish options. Finish options are separated by a vertical ruled line. Lead finish/Ball material values may wrap to two lines if the finish value exceeds the maximum column width.

(5) **MSL rating/Peak reflow:** The moisture sensitivity level ratings and peak solder (reflow) temperatures. In the event that a part has multiple moisture sensitivity ratings, only the lowest level per JEDEC standards is shown. Refer to the shipping label for the actual reflow temperature that will be used to mount the part to the printed circuit board.

(6) **Part marking:** There may be an additional marking, which relates to the logo, the lot trace code information, or the environmental category of the part.

Multiple part markings will be inside parentheses. Only one part marking contained in parentheses and separated by a "~" will appear on a part. If a line is indented then it is a continuation of the previous line and the two combined represent the entire part marking for that device.

**Important Information and Disclaimer:** The information provided on this page represents TI's knowledge and belief as of the date that it is provided. TI bases its knowledge and belief on information provided by third parties, and makes no representation or warranty as to the accuracy of such information. Efforts are underway to better integrate information from third parties. TI has taken and continues to take reasonable steps to provide representative and accurate information but may not have conducted destructive testing or chemical analysis on incoming materials and chemicals. TI and TI suppliers consider certain information to be proprietary, and thus CAS numbers and other limited information may not be available for release.

In no event shall TI's liability arising out of such information exceed the total purchase price of the TI part(s) at issue in this document sold by TI to Customer on an annual basis.

**OTHER QUALIFIED VERSIONS OF TUSB211A :**

- Automotive : [TUSB211A-Q1](#)

NOTE: Qualified Version Definitions:

- Automotive - Q100 devices qualified for high-reliability automotive applications targeting zero defects

**TAPE AND REEL INFORMATION**

**QUADRANT ASSIGNMENTS FOR PIN 1 ORIENTATION IN TAPE**

\*All dimensions are nominal

Device	Package Type	Package Drawing	Pins	SPQ	Reel Diameter (mm)	Reel Width W1 (mm)	A0 (mm)	B0 (mm)	K0 (mm)	P1 (mm)	W (mm)	Pin1 Quadrant
TUSB211AIRWBR	X2QFN	RWB	12	3000	180.0	9.5	1.8	1.8	0.45	4.0	8.0	Q1
TUSB211ARWBR	X2QFN	RWB	12	3000	180.0	9.5	1.8	1.8	0.45	4.0	8.0	Q1

**TAPE AND REEL BOX DIMENSIONS**

\*All dimensions are nominal

Device	Package Type	Package Drawing	Pins	SPQ	Length (mm)	Width (mm)	Height (mm)
TUSB211AIRWBR	X2QFN	RWB	12	3000	189.0	185.0	36.0
TUSB211ARWBR	X2QFN	RWB	12	3000	189.0	185.0	36.0



# EXAMPLE BOARD LAYOUT

RWB0012A

X2QFN - 0.4 mm max height

PLASTIC QUAD FLATPACK - NO LEAD

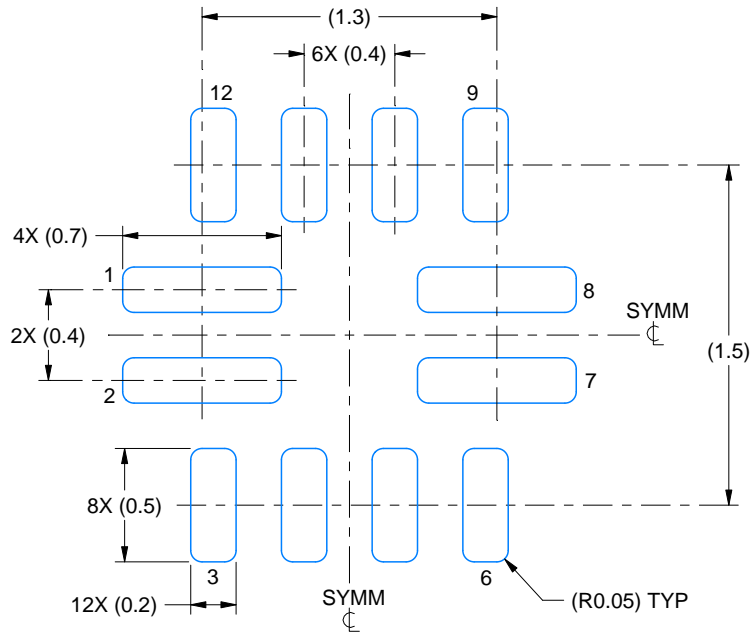

LAND PATTERN EXAMPLE  
EXPOSED METAL SHOWN  
SCALE:30X

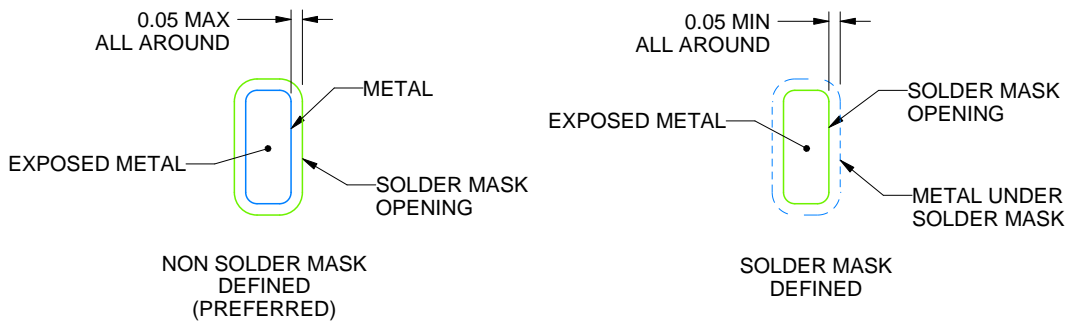

SOLDER MASK DETAILS

4221631/B 07/2017

NOTES: (continued)

3. For more information, see Texas Instruments literature number SLUA271 ([www.ti.com/lit/slua271](http://www.ti.com/lit/slua271)).

# EXAMPLE STENCIL DESIGN

RWB0012A

X2QFN - 0.4 mm max height

PLASTIC QUAD FLATPACK - NO LEAD

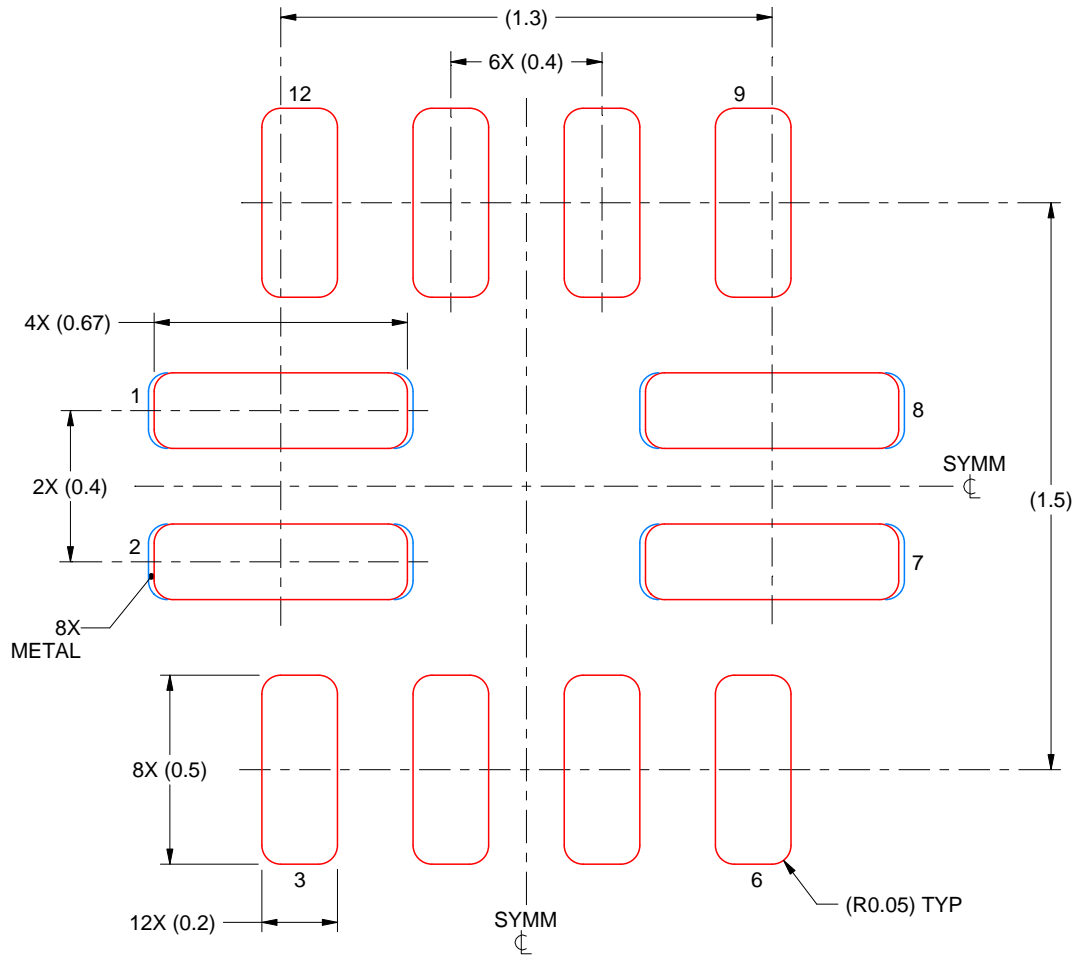

**SOLDER PASTE EXAMPLE**  
BASED ON 0.1 mm THICK STENCIL  
PADS 1,2,7 & 8  
96% PRINTED SOLDER COVERAGE BY AREA  
SCALE:50X

4221631/B 07/2017

NOTES: (continued)

4. Laser cutting apertures with trapezoidal walls and rounded corners may offer better paste release. IPC-7525 may have alternate design recommendations.

## IMPORTANT NOTICE AND DISCLAIMER

TI PROVIDES TECHNICAL AND RELIABILITY DATA (INCLUDING DATASHEETS), DESIGN RESOURCES (INCLUDING REFERENCE DESIGNS), APPLICATION OR OTHER DESIGN ADVICE, WEB TOOLS, SAFETY INFORMATION, AND OTHER RESOURCES "AS IS" AND WITH ALL FAULTS, AND DISCLAIMS ALL WARRANTIES, EXPRESS AND IMPLIED, INCLUDING WITHOUT LIMITATION ANY IMPLIED WARRANTIES OF MERCHANTABILITY, FITNESS FOR A PARTICULAR PURPOSE OR NON-INFRINGEMENT OF THIRD PARTY INTELLECTUAL PROPERTY RIGHTS.

These resources are intended for skilled developers designing with TI products. You are solely responsible for (1) selecting the appropriate TI products for your application, (2) designing, validating and testing your application, and (3) ensuring your application meets applicable standards, and any other safety, security, regulatory or other requirements.

These resources are subject to change without notice. TI grants you permission to use these resources only for development of an application that uses the TI products described in the resource. Other reproduction and display of these resources is prohibited. No license is granted to any other TI intellectual property right or to any third party intellectual property right. TI disclaims responsibility for, and you fully indemnify TI and its representatives against any claims, damages, costs, losses, and liabilities arising out of your use of these resources.

TI's products are provided subject to [TI's Terms of Sale](#), [TI's General Quality Guidelines](#), or other applicable terms available either on [ti.com](#) or provided in conjunction with such TI products. TI's provision of these resources does not expand or otherwise alter TI's applicable warranties or warranty disclaimers for TI products. Unless TI explicitly designates a product as custom or customer-specified, TI products are standard, catalog, general purpose devices.

TI objects to and rejects any additional or different terms you may propose.

Copyright © 2025, Texas Instruments Incorporated

Last updated 10/2025

## Looking for pricing, stock, or lifecycle information?

Click below to explore more details on WIN SOURCE:

- ⊖ [View TUSB211AIRWBR on WIN SOURCE](#)
- ⊖ [Texas Instruments](#) Information

## Optimize Your Supply Chain with WIN SOURCE Solutions

- ✓ Global Sourcing Solution
- ✓ Obsolete Management
- ✓ Cost Control Management
- ✓ Shortage Management
- ✓ Alternative Solution
- ✓ Excess Inventory Management