



**THE DATASHEET OF
ZEN132V130A24YC**



POLYZEN DEVICES

Polymer Protected Zener Diode

PolyZen devices are polymer-enhanced, precision Zener diodes. They offer resettable protection against multi-Watt fault events without the need for multi-Watt heat sinks.

The Zener diode used for voltage clamping a PolyZen device was selected due to its relatively flat voltage vs. current response. This helps improve output voltage clamping, even when input voltage is high and diode currents are large.

An advanced feature of the PolyZen device is that the Zener diode is thermally coupled to a resistively non-linear, PPTC (polymer positive temperature coefficient) layer. This PPTC layer is fully integrated into the device and is electrically in series between V_{IN} and the diode clamped V_{OUT} .

This advanced PPTC layer responds to either extended diode heating or overcurrent events by transitioning from a low to high resistance state, also known as “tripping.” A tripped PPTC will limit current and generate voltage drop. It helps to protect both the Zener diode and the follow-on electronics and effectively increases the diode’s power handling capability.

The polymer-enhanced Zener diode helps protect sensitive portable electronics from damage caused by inductive voltage spikes, voltage transients, incorrect power supplies and reverse bias. These devices are particularly suitable for portable electronics and other low-power DC devices.

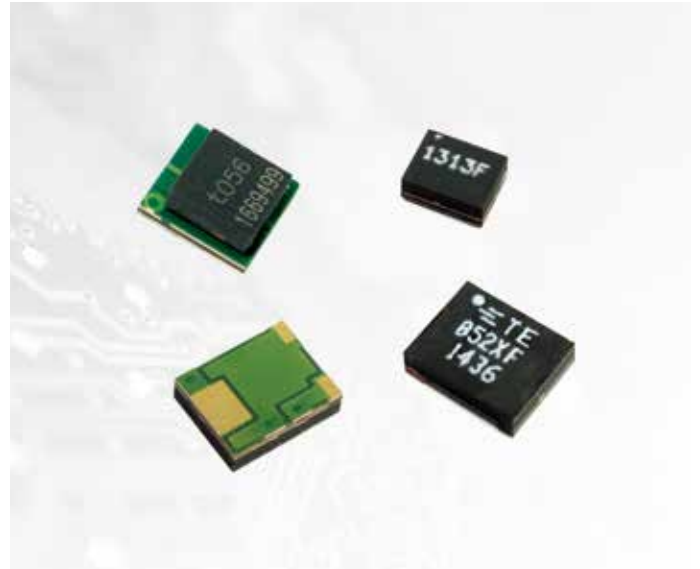

BENEFITS

- Stable Zener diode helps shield downstream electronics from overvoltage and reverse bias
- Trip events shut out overvoltage and reverse bias sources
- Analog nature of trip events helps minimize damage from upstream inductive spikes
- Minimal power dissipation requirements
- Single component placement

FEATURES

- Overvoltage transient suppression
- Stable V_Z vs. fault current
- Time delayed, overvoltage trip
- Time delayed, reverse bias trip

APPLICATIONS

- DC power port protection in portable electronics
- DC power port protection for systems using barrel jacks for power input
- Internal overvoltage and transient suppression
- DC output voltage regulation
- Tablet PCs and portable electronics

- Multi-Watt power handling capability
- Integrated device construction
- RoHS compliant
- Halogen free
(refers to: Br≤900ppm, Cl≤900ppm, Br+Cl≤1500ppm)

Figure PZ1 – Typical Application Block Diagram

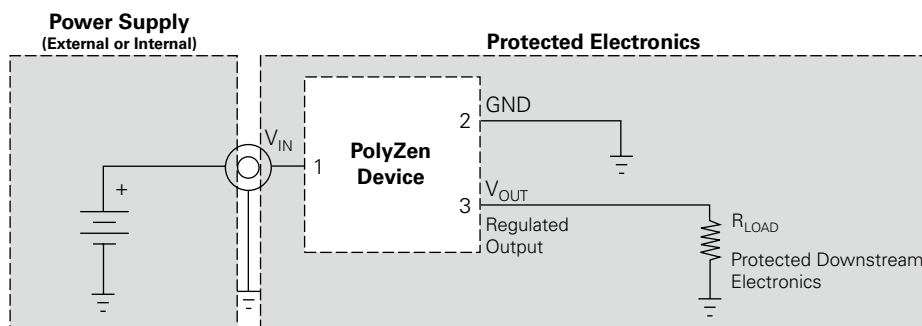

Table PZ1 – Electrical Characteristics

(Performance ratings @ 25°C unless otherwise specified)

| Part Number | V_Z (V) | | | I_{ZT} (A) | I_{HOLD} @ 20°C (A) | R_{Typ} (Ω) | R_{1MAX} (Ω) | $V_{INT MAX}$ | | $I_{FLT MAX}$ | |
|---------------------|-----------|-------|-------|--------------|-----------------------|------------------------|-------------------------|-------------------|------------------|-------------------|------------------|
| | Min | Typ | Max | | | | | $V_{INT MAX}$ (V) | Test Current (A) | $I_{FLT MAX}$ (A) | Test Voltage (V) |
| ZEN056V130A24LS | 5.45 | 5.60 | 5.75 | 0.10 | 1.30 | 0.12 | 0.16 | 24 | 3 | +10/-40 | +24/-16 |
| ZEN059V130A24LS† | 5.80 | 5.90 | 6.00 | 0.10 | 1.30 | 0.12 | 0.15 | 24 | 3 | +6/-40 | +24/-16 |
| ZEN065V130A24LS | 6.35 | 6.50 | 6.65 | 0.10 | 1.30 | 0.12 | 0.16 | 24 | 3 | +6/-40 | +24/-16 |
| ZEN098V130A24LS | 9.60 | 9.80 | 10.00 | 0.10 | 1.30 | 0.12 | 0.16 | 24 | 3 | +3.5/-40 | +24/-16 |
| ZEN132V130A24LS | 13.20 | 13.40 | 13.60 | 0.10 | 1.30 | 0.12 | 0.16 | 24 | 3 | +2/-40 | +24/-16 |
| ZEN164V130A24LS | 16.10 | 16.40 | 16.60 | 0.10 | 1.30 | 0.12 | 0.16 | 24 | 3 | +1.25/-40 | +24/-16 |
| ZEN056V230A16LS | 5.45 | 5.60 | 5.75 | 0.10 | 2.30 | 0.04 | 0.06 | 16 | 5 | +5/-40 | +16/-12 |
| ZEN065V230A16LS | 6.35 | 6.50 | 6.65 | 0.10 | 2.30 | 0.04 | 0.06 | 16 | 5 | +3.5/-40 | +16/-12 |
| ZEN098V230A16LS | 9.60 | 9.80 | 10.00 | 0.10 | 2.30 | 0.04 | 0.06 | 16 | 5 | +3.5/-40 | +16/-12 |
| ZEN132V230A16LS | 13.20 | 13.40 | 13.60 | 0.10 | 2.30 | 0.04 | 0.06 | 16 | 5 | +2/-40 | +20/-12 |
| ZEN056V075A48LS | 5.45 | 5.60 | 5.75 | 0.10 | 0.75 | 0.28 | 0.45 | 48 | 3 | +10/-40 | +48/-16 |
| ZEN132V075A48LS | 13.20 | 13.40 | 13.60 | 0.10 | 0.75 | 0.28 | 0.45 | 48 | 3 | +2/-40 | +48/-16 |
| ZEN056V115A24LS | 5.45 | 5.60 | 5.75 | 0.10 | 1.15 | 0.15 | 0.18 | 24 | 3 | +10/-40 | +24/-16 |
| NEW ZEN056V130A16YM | 5.35 | 5.60 | 5.85 | 0.10 | 1.30 | 0.110 | 0.160 | 14 | 3 | +3/-40 | +16/-12 |
| NEW ZEN056V175A12YM | 5.35 | 5.60 | 5.85 | 0.10 | 1.75 | 0.050 | 0.095 | 12 | 4 | +3/-40 | +12/-12 |
| NEW ZEN132V130A16YM | 13.20 | 13.40 | 13.80 | 0.10 | 1.30 | 0.110 | 0.160 | 14 | 3 | +1/-40 | +20/-12 |
| NEW ZEN132V175A12YM | 13.20 | 13.40 | 13.80 | 0.10 | 1.75 | 0.050 | 0.095 | 12 | 4 | +1/-40 | +20/-12 |
| NEW ZEN056V130A24YC | 5.35 | 5.60 | 5.85 | 0.10 | 1.30 | 0.110 | 0.170 | 24 | 3 | +4/-40 | +24/-16 |
| NEW ZEN056V230A16YC | 5.35 | 5.60 | 5.85 | 0.10 | 2.30 | 0.040 | 0.070 | 16 | 5 | +3/-40 | +16/-12 |
| NEW ZEN056V260A16YC | 5.35 | 5.60 | 5.85 | 0.10 | 2.60 | 0.040 | 0.055 | 16 | 5 | +3/-40 | +16/-12 |
| NEW ZEN132V130A24YC | 13.20 | 13.40 | 13.80 | 0.10 | 1.30 | 0.110 | 0.170 | 24 | 3 | +1/-40 | +24/-16 |
| NEW ZEN132V230A16YC | 13.20 | 13.40 | 13.80 | 0.10 | 2.30 | 0.040 | 0.070 | 16 | 5 | +1/-40 | +20/-12 |
| NEW ZEN132V260A16YC | 13.20 | 13.40 | 13.80 | 0.10 | 2.60 | 0.040 | 0.055 | 16 | 5 | +1/-40 | +20/-12 |

LS module height is 1.7mm typical. YM module height is 1.2mm typical. YC module height is 1.3mm typical.

† Typical operating current is 500µA @ 5.0V which meets USB suspend mode requirement.

Table PZ2 – Definition of Terms

| | |
|---------------|---|
| V_Z | Zener clamping voltage measured at current I_{ZT} and 20°C. |
| I_{ZT} | Test current at which V_Z is measured. |
| I_{HOLD} | Maximum steady state current I_{PTC} that will not generate a trip event at the specified temperature. Ratings assume $I_{FLT} = 0A$. |
| R_{Typ} | Typical resistance between V_{IN} and V_{OUT} pins when the device is at room temperature. |
| R_{1MAX} | The maximum resistance between V_{IN} and V_{OUT} pins, at room temperature, one hour after first trip or after reflow soldering. |
| I_{FLT} | Current flowing through the Zener diode. |
| $I_{FLT MAX}$ | Maximum RMS fault current the Zener diode component of the device can withstand and remain resettable; testing is conducted at rated voltage with no load connected to V_{OUT} . |
| $V_{INT MAX}$ | The voltage ($V_{IN} - V_{OUT}$ "post trip") at which typical qualification devices (98% devices, 95% confidence) survived at least 100 trip cycles and 24 hours trip endurance when "tripped" at the specified voltage and current (I_{PTC}). |
| I_{PTC} | Current flowing through the PPTC portion of the circuit. |
| I_{OUT} | Current flowing out the V_{OUT} pin of the device. |
| Trip Event | A condition where the PPTC transitions to a high resistance state, thereby limiting I_{PTC} , and significantly increasing the voltage drop between V_{IN} and V_{OUT} . |

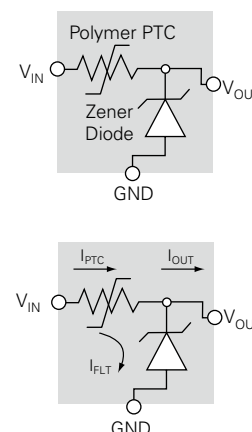

Figures PZ2-PZ9 – Typical Performance Curves for PolyZen Devices - LS Series

Figure PZ2

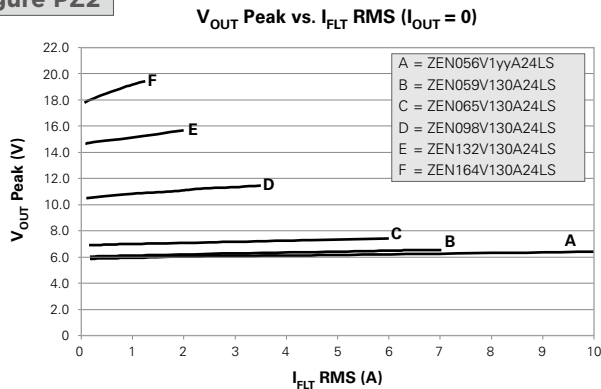

Figure PZ3

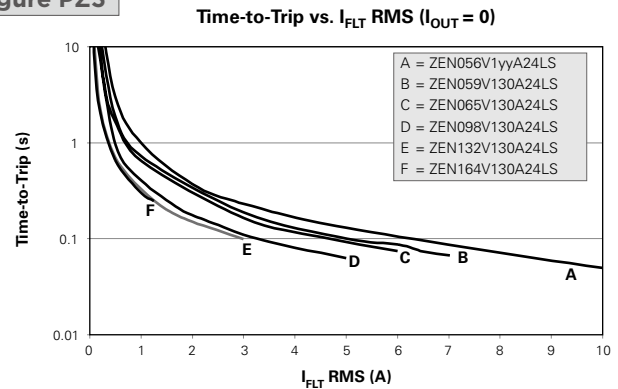

Figure PZ4

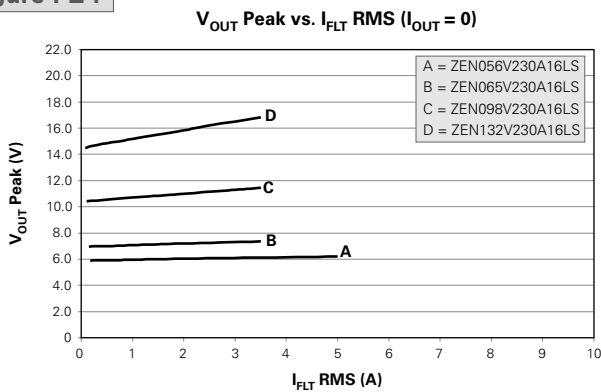

Figure PZ5

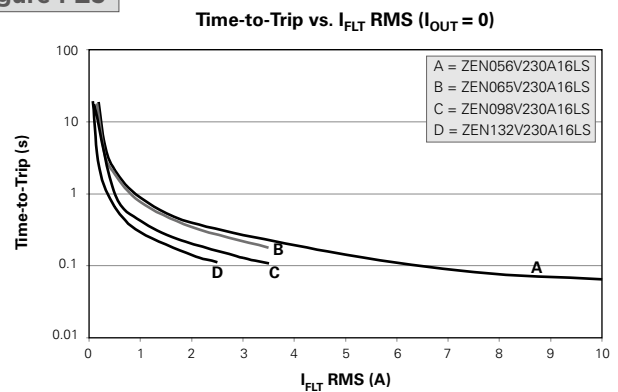

Figure PZ6

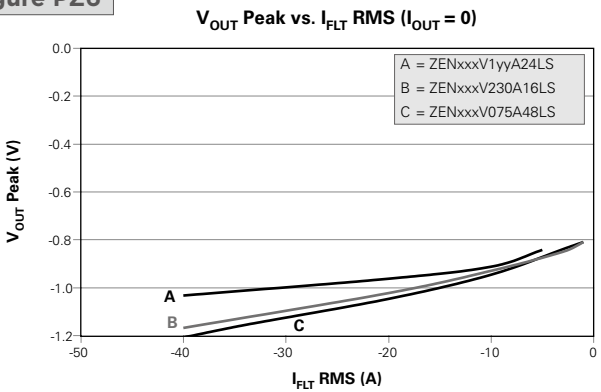

Figure PZ7

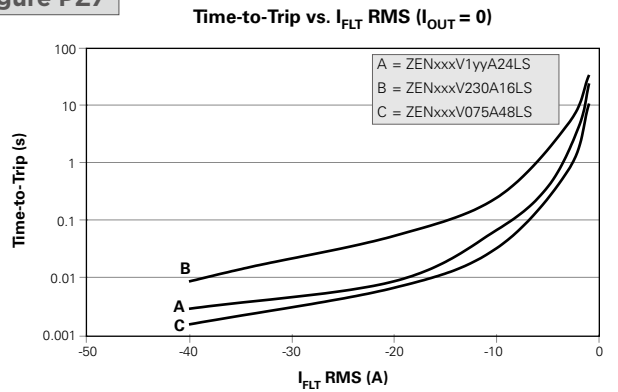

Figure PZ8

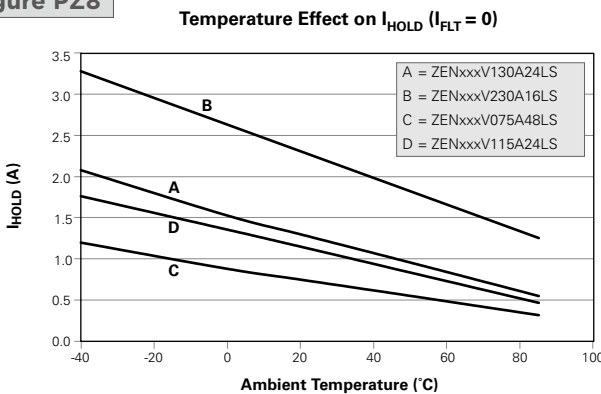
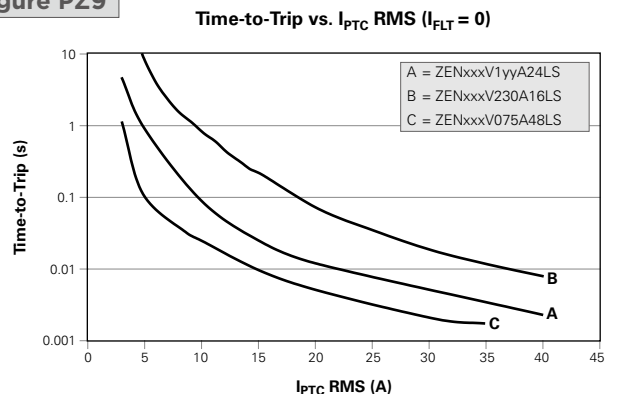
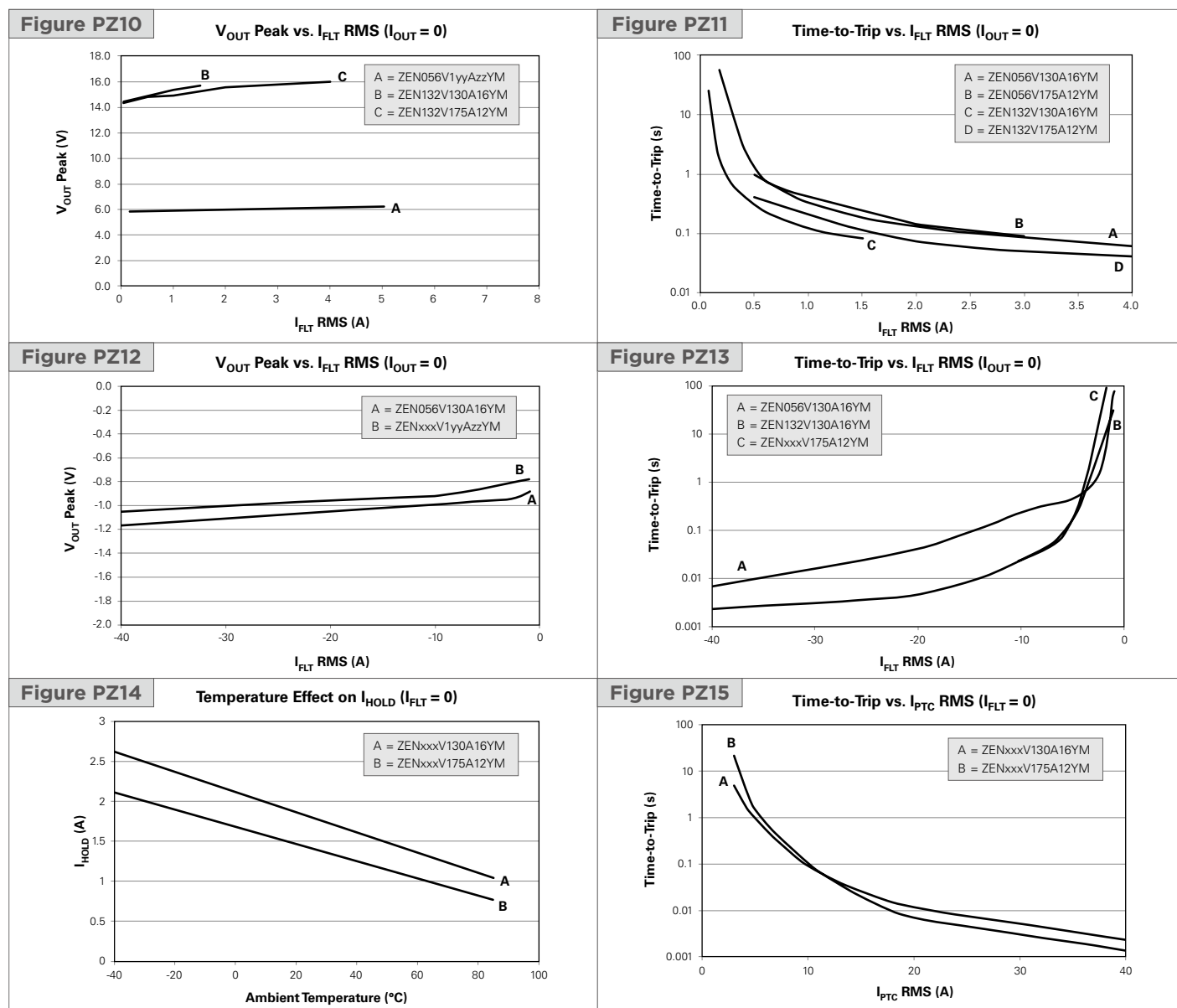

Figure PZ9



Figures PZ10-PZ15 — Typical Performance Curves for PolyZen Devices - YM Series



Figures PZ16-PZ21 — Typical Performance Curves for PolyZen Devices - YC Series

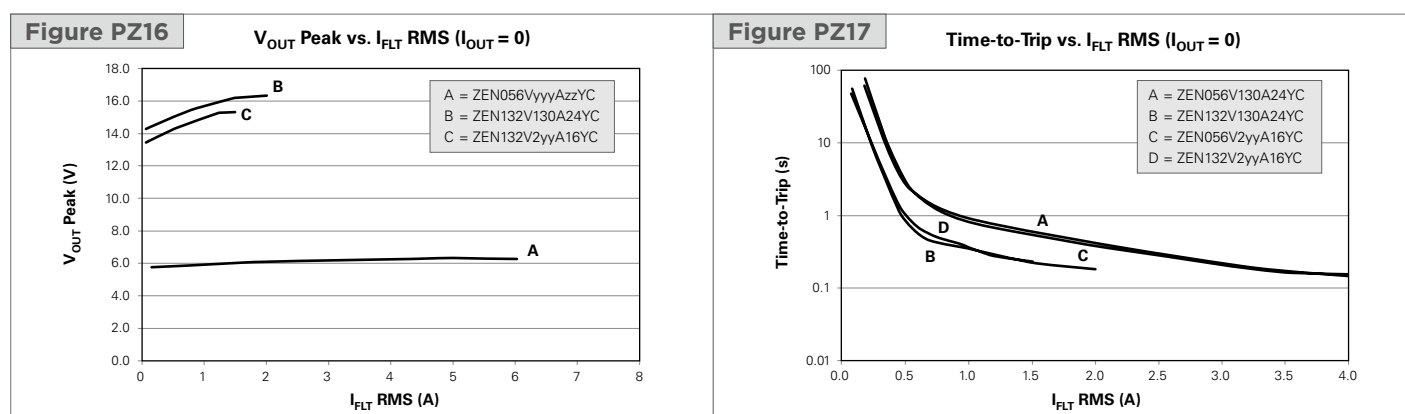

4 PolyZen Devices Polymer Protected Zener Diode

Figures PZ16-PZ21 — Typical Performance Curves for PolyZen Devices - YC Series (Cont'd)

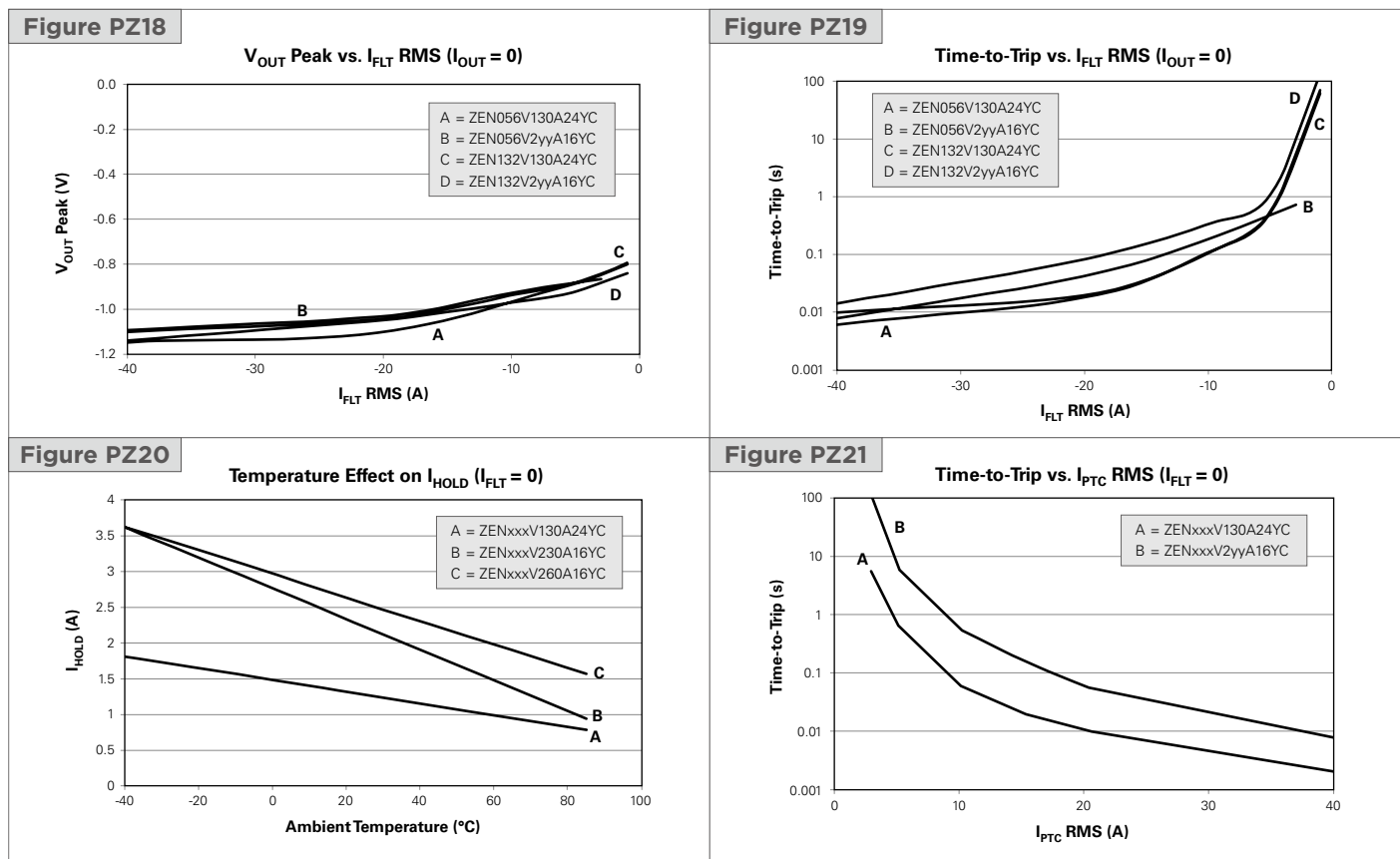
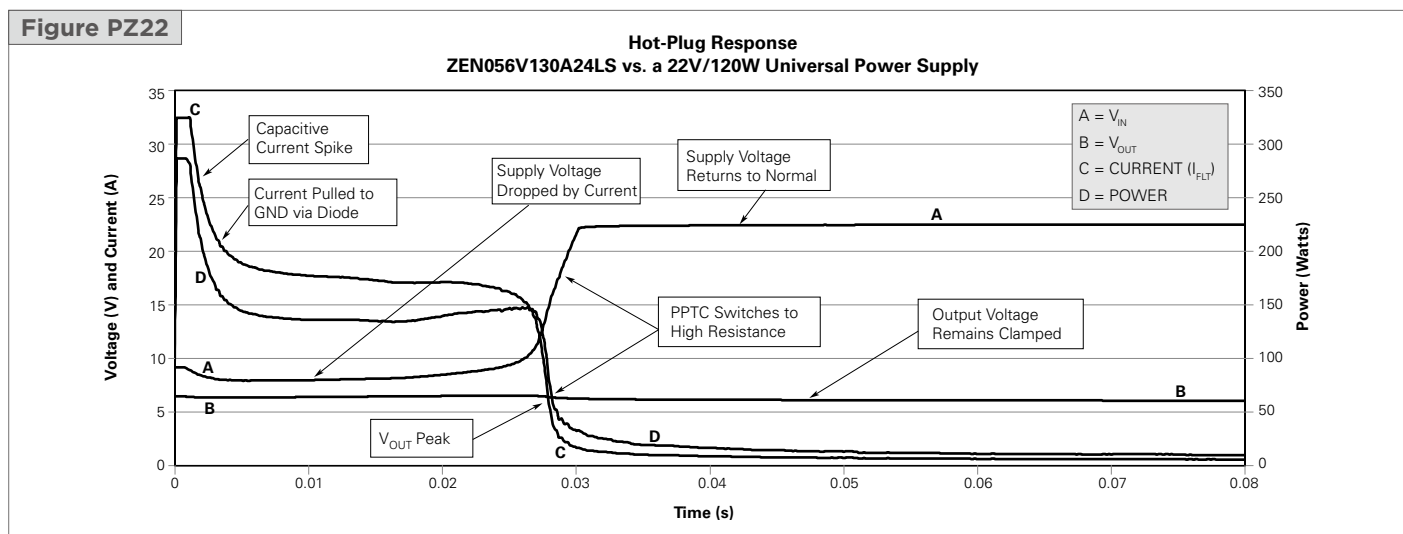

Table PZ3 — General Characteristics for PolyZen Devices

| | |
|-----------------------------|-------------------------------|
| Operating temperature range | -40° to +85°C |
| Storage temperature | -40° to +85°C |
| ESD withstand | 15kV Human body model |
| Diode capacitance | 4200pF Typical @ 1MHz, 1V RMS |
| Construction | RoHS compliant |

Figures PZ22-PZ34 — Basic Operation Examples for PolyZen Devices - LS Series



Figures PZ22-PZ34 — Basic Operation Examples for PolyZen Devices - LS Series (Cont'd)

Figure PZ23

Typical Fault Response: ZEN056V1xxA24LS
20V, 3.5A Current Limited Source ($I_{OUT}=0$)

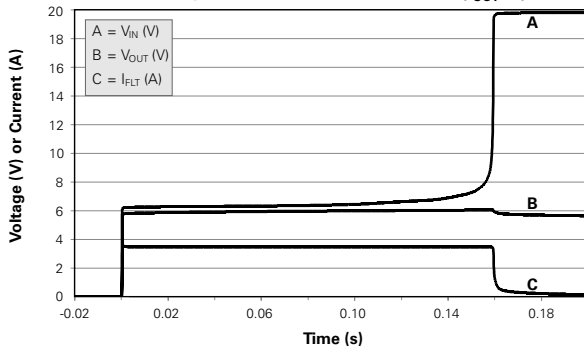

Figure PZ24

Typical Fault Response: ZEN059V130A24LS
24V, 6A Current Limited Source ($I_{OUT}=0$)

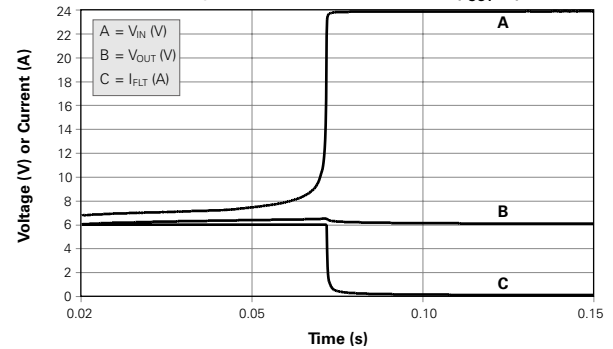

Figure PZ25

Typical Fault Response: ZEN065V130A24LS
24V, 5.0A Current Limited Source ($I_{OUT}=0$)

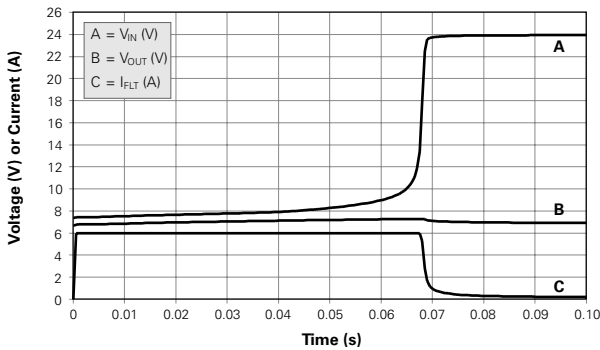

Figure PZ26

Typical Fault Response: ZEN098V130A24LS
24V, 3.5A Current Limited Source ($I_{OUT}=0$)

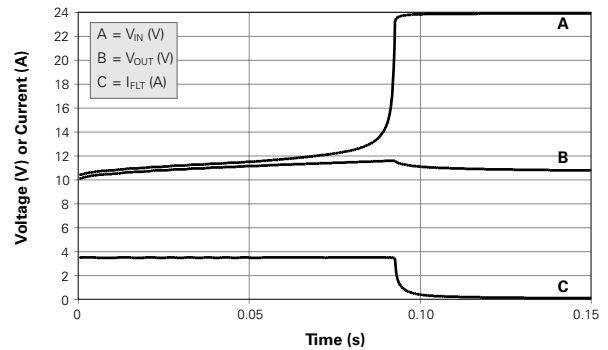

Figure PZ27

Typical Fault Response: ZEN132V130A24LS
24V, 2.0A Current Limited Source ($I_{OUT}=0$)

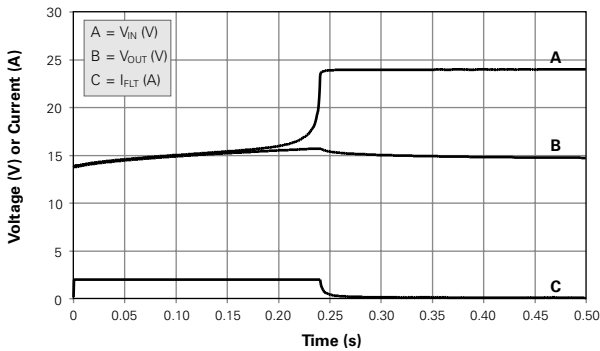

Figure PZ28

Typical Fault Response: ZEN164V130A24LS
24V, 1.0A Current Limited Source ($I_{OUT}=0$)

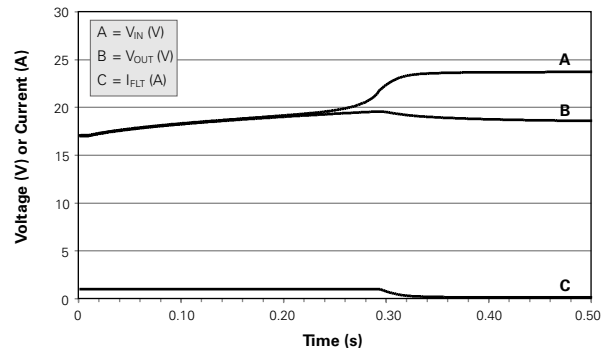

Figure PZ29

Typical Fault Response: ZEN056V230A16LS
16V, 5.0A Current Limited Source ($I_{OUT}=0$)

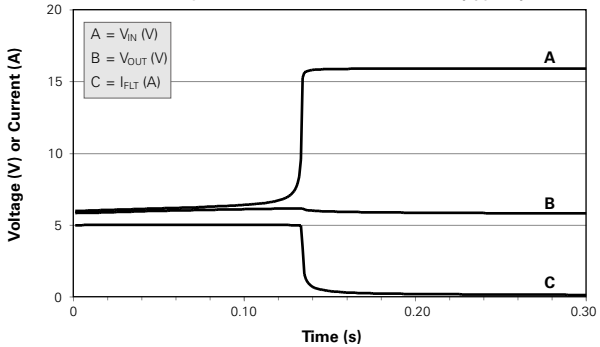
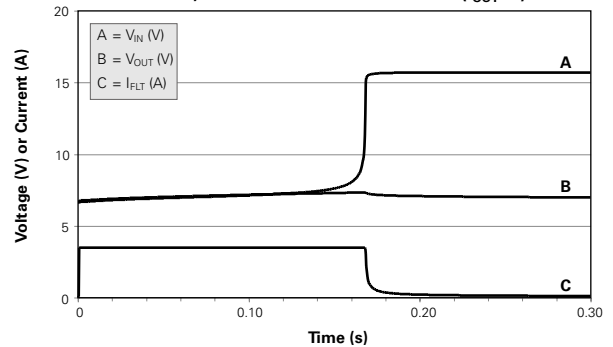
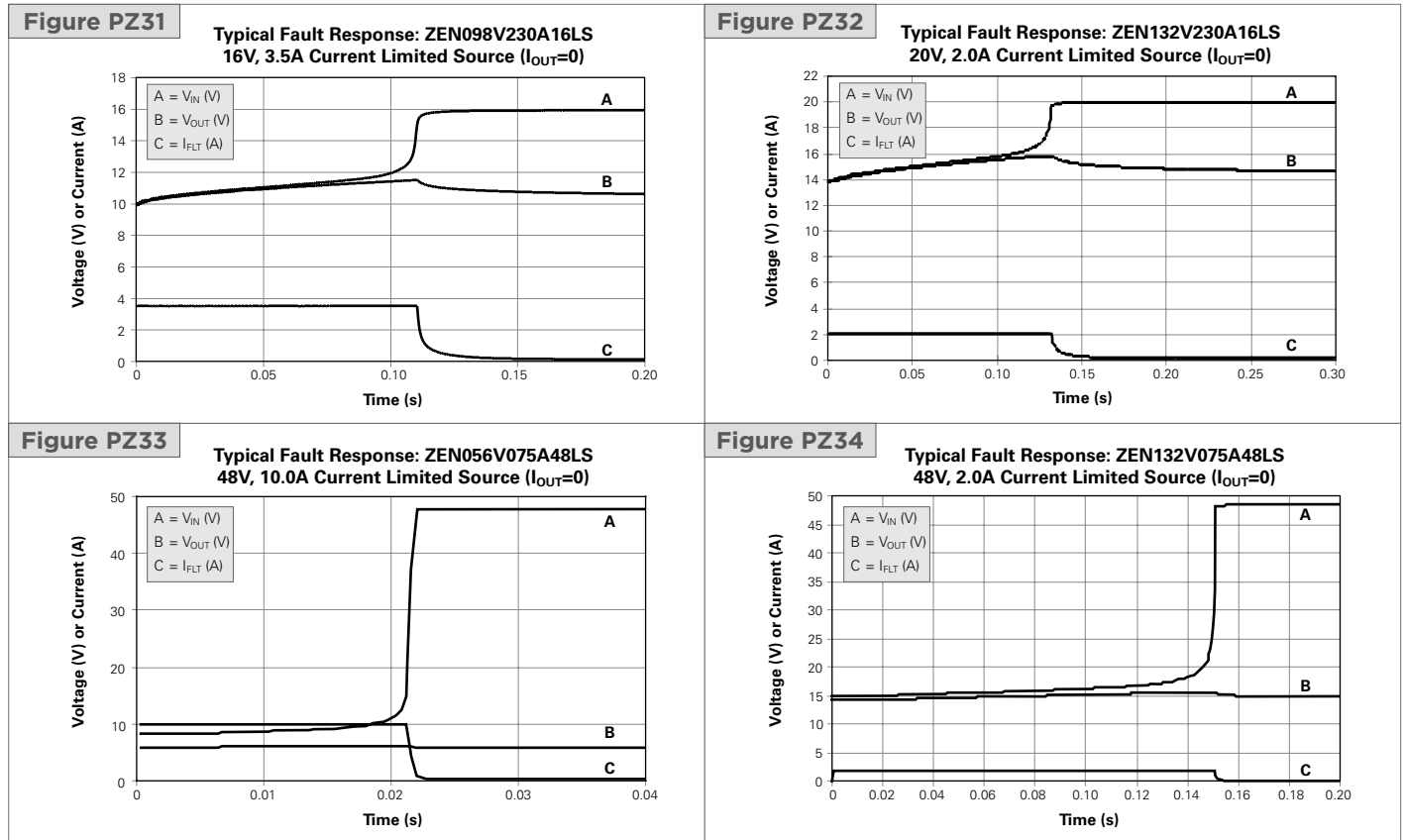

Figure PZ30

Typical Fault Response: ZEN065V230A16LS
16V, 3.5A Current Limited Source ($I_{OUT}=0$)



Figures PZ22-PZ34 – Basic Operation Examples for PolyZen Devices - LS Series (Cont'd)



Figures PZ35-PZ38 – Basic Operation Examples for PolyZen Devices - YM Series

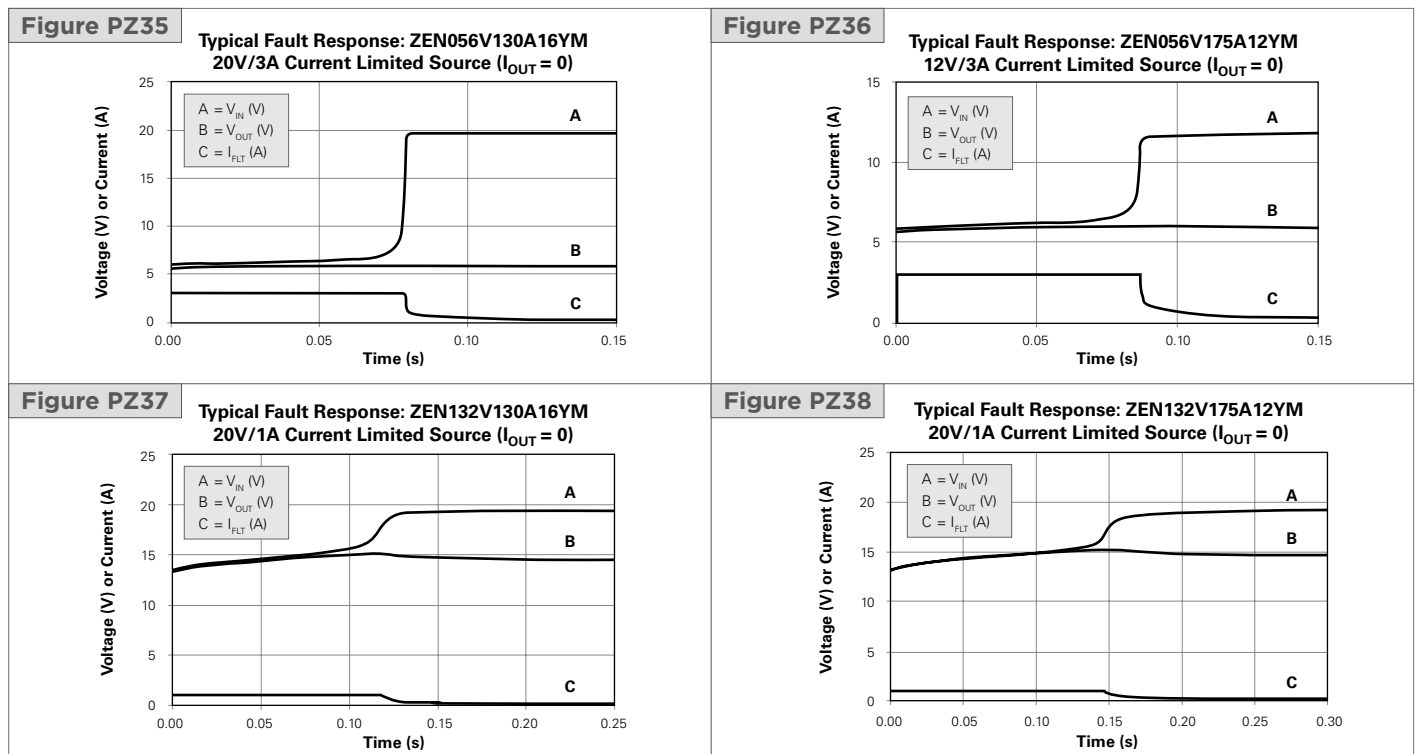

Figures PZ39-PZ44 – Basic Operation Examples for PolyZen Devices - YC Series

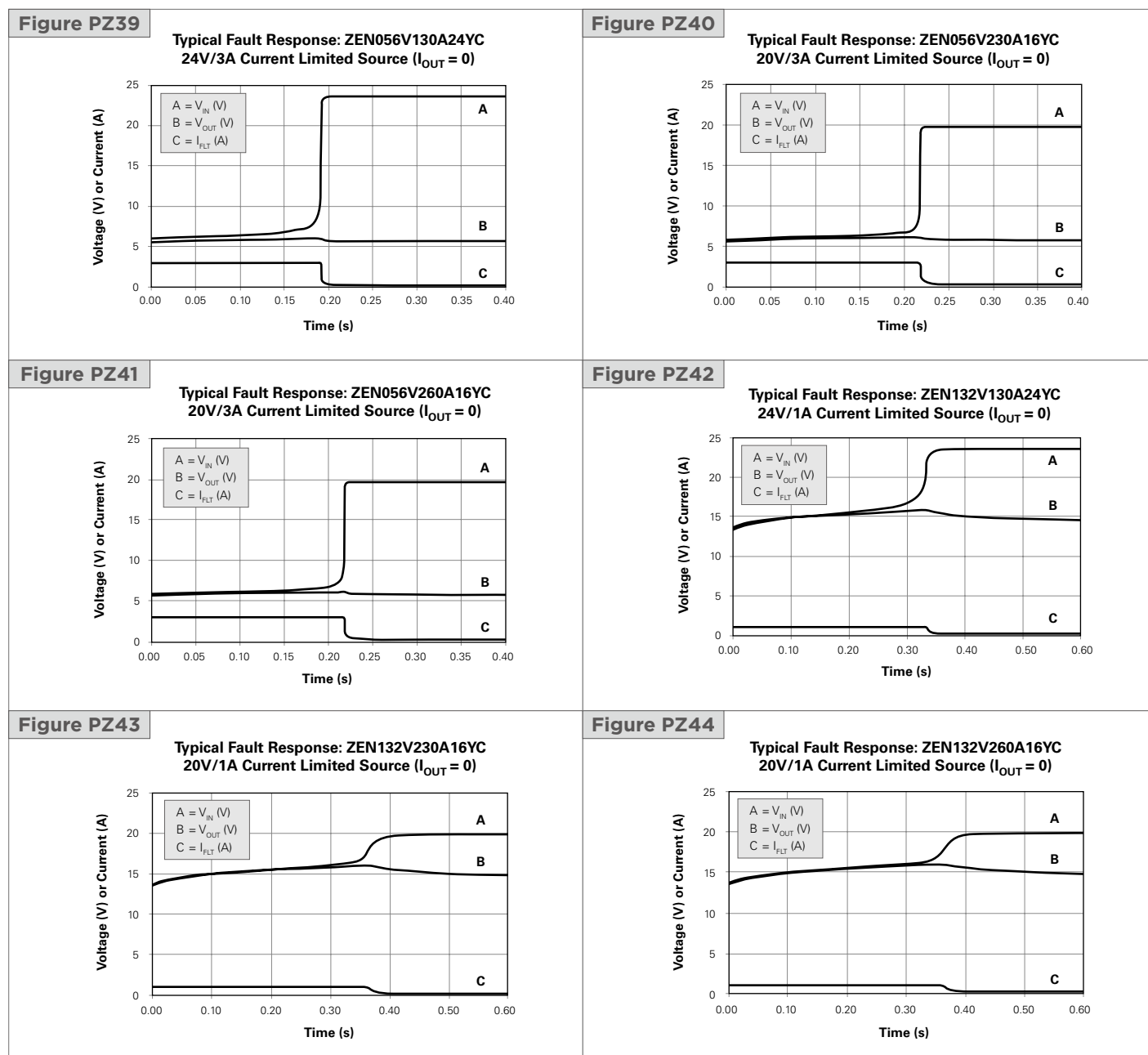

Table PZ4 - Packaging and Marking Information for PolyZen Devices

| Part Number | Bag Quantity | Tape & Reel Quantity | Standard Package |
|-----------------|--------------|----------------------|------------------|
| ZENxxxVyyyAzzLS | — | 3,000 | 15,000 |
| ZENxxxVyyyAzzYM | — | 3,000 | 30,000 |
| ZENxxxVyyyAzzYC | — | 4,000 | 20,000 |

4 PolyZen Devices Polymer Protected Zener Diode

Table PZ5 – Dimensions in Millimeters and (Inches)

ZENxxxVyyyAzzLS Devices

| | A | | B | | C | |
|----|---------|---------|---------|---------|---------|---------|
| | Min | Max | Min | Max | Min | Max |
| mm | 3.85 | 4.15 | 3.85 | 4.15 | 1.40 | 2.00 |
| in | (0.152) | (0.163) | (0.152) | (0.163) | (0.055) | (0.081) |

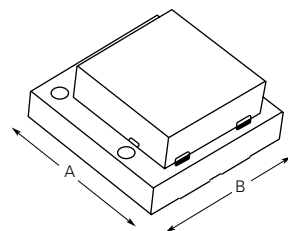

ZENxxxVyyyAzzYM Devices

| | A | | B | | C | |
|----|---------|---------|---------|---------|---------|---------|
| | Min | Max | Min | Max | Min | Max |
| mm | 3.00 | 3.40 | 2.30 | 2.70 | 1.10 | 1.30 |
| in | (0.118) | (0.134) | (0.091) | (0.106) | (0.043) | (0.051) |

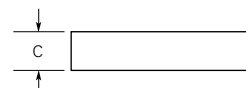

ZENxxxVyyyAzzYC Devices

| | A | | B | | C | |
|----|---------|---------|---------|---------|---------|---------|
| | Min | Max | Min | Max | Min | Max |
| mm | 4.80 | 5.20 | 3.80 | 4.20 | 1.20 | 1.40 |
| in | (0.190) | (0.206) | (0.150) | (0.166) | (0.047) | (0.055) |

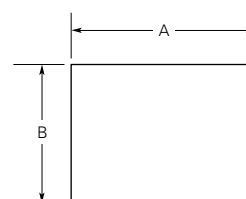
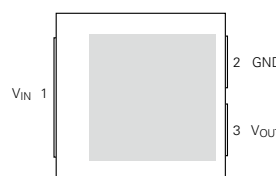

Table PZ6 – Pad Layout and Configuration Information

ZENxxxVyyyAzzLS Devices

| Pin Number | Pin Name | Pin Function |
|------------|-----------|--|
| 1 | V_{IN} | V_{IN} = Protected input to Zener diode |
| 2 | GND | GND = Ground |
| 3 | V_{OUT} | V_{OUT} = Zener regulated voltage output |

Pin Configuration (Top View)



Pad Dimensions

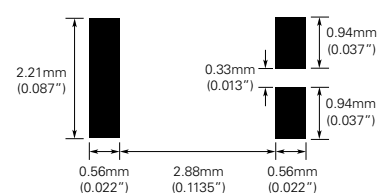

ZENxxxVyyyAzzYM Devices

| Pin Number | Pin Name | Pin Function |
|------------|-----------|--|
| 1 | V_{IN} | V_{IN} = Protected input to Zener diode |
| 2 | GND | GND = Ground |
| 3 | V_{OUT} | V_{OUT} = Zener regulated voltage output |

Pin Configuration (Top View)

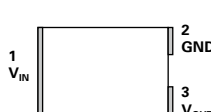

Recommended Pad Dimensions (mm)

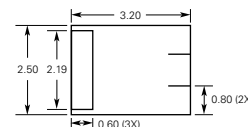

Recommended Pad Layout (mm)

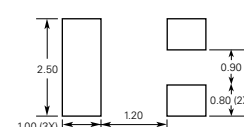

ZENxxxVyyyAzzYC Devices

| Pin Number | Pin Name | Pin Function |
|------------|-----------|--|
| 1 | V_{IN} | V_{IN} = Protected input to Zener diode |
| 2 | GND | GND = Ground |
| 3 | V_{OUT} | V_{OUT} = Zener regulated voltage output |

Pin Configuration (Top View)

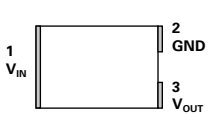

Recommended Pad Dimensions (mm)

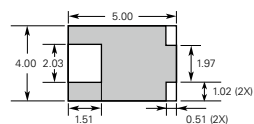

Recommended Pad Layout (mm)

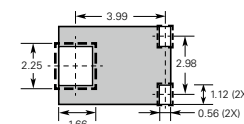

Solder Reflow and Rework Recommendation

Classification Reflow Profiles

| Profile Feature | ZENxxxVyyyAzzLS Devices | ZENxxxVyyyAzzYM Devices | ZENxxxVyyyAzzYC Devices |
|--|-------------------------|-------------------------|-------------------------|
| | Pb-Free Assembly | | Pb-Free Assembly |
| Average Ramp Up Rate (Ts_{MAX} to Tp) | 3°C/ s Max | | 3°C/ s Max |
| Preheat | | | |
| • Temperature Min (Ts _{MIN}) | 150°C | | 150°C |
| • Temperature Max (Ts _{MAX}) | 200°C | | 200°C |
| • Time (ts Preheat) | 60-180 s | | 60-180 s |
| Time Maintained Above: | | | |
| • Temperature (T _L) | 217°C | | 217°C |
| • Time (t _L) | 60-150 s | | 60-150 s |
| Peak/Classification Temperature (Tp) | 260°C | | 250°C |
| Time within 5°C of Actual Peak Temperature | | | |
| Time (tp) | 20-40 s | | 20-40 s |
| Average Ramp Down Rate (Tp to T_L) | 6°C/ s Max | | 3°C/ s Max |
| Time 25°C to Peak Temperature | 8 Minutes Max | | 8 Minutes Max |

Note: All temperatures refer to top side of the package, measured on the package body surface.

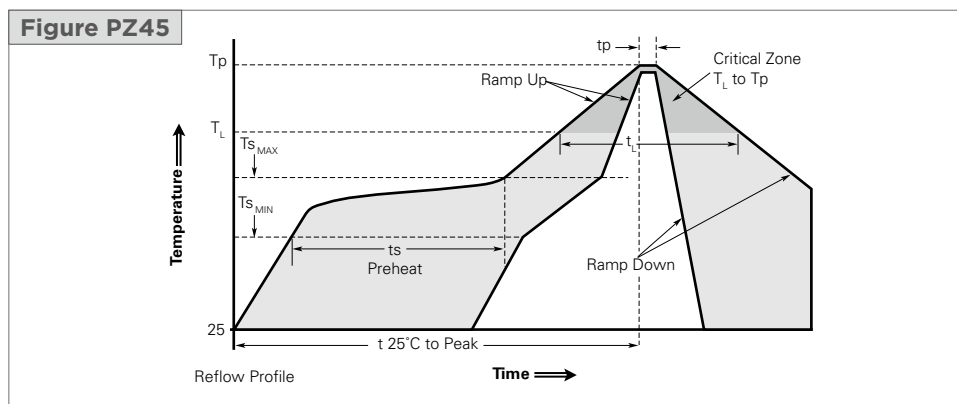

Tape and Reel Specifications for PolyZen Devices in Millimeters

Figure PZ46 – EIA Referenced Taped Component Dimensions for ZENxxxVyyyAzzLS Devices in Millimeters (mm)

| Description | ZENxxxVyyyAzzLS Devices |
|----------------|-------------------------|
| A ₀ | 4.35 |
| B ₀ | 4.35 |
| K ₀ | 2.30 |

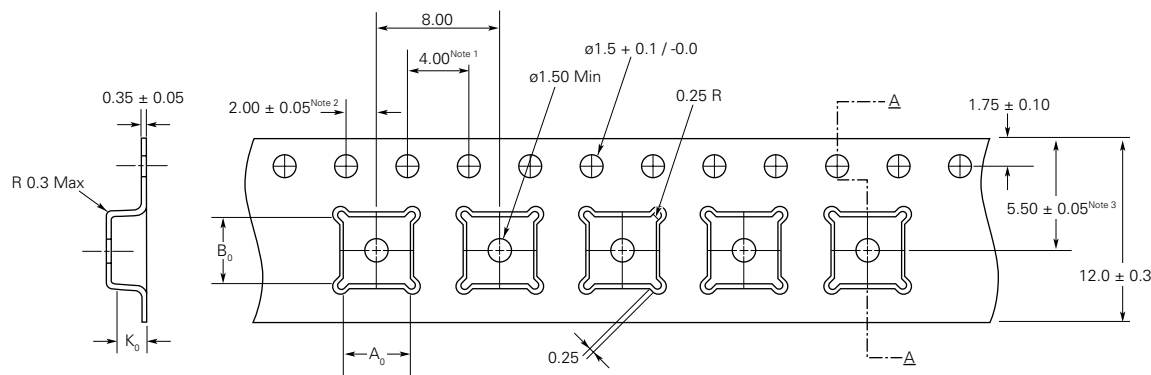

- Notes:**
1. 10 sprocket hole pitch cumulative tolerance ± 0.2
 2. Camber in compliance with EIA 481
 3. Pocket position relative to sprocket hole measured as true position of pocket, not pocket hole

4 PolyZen Devices Polymer Protected Zener Diode

Figure PZ47 – Reel Dimensions for ZENxxxVyyyAzzLS Devices in Millimeters (mm)

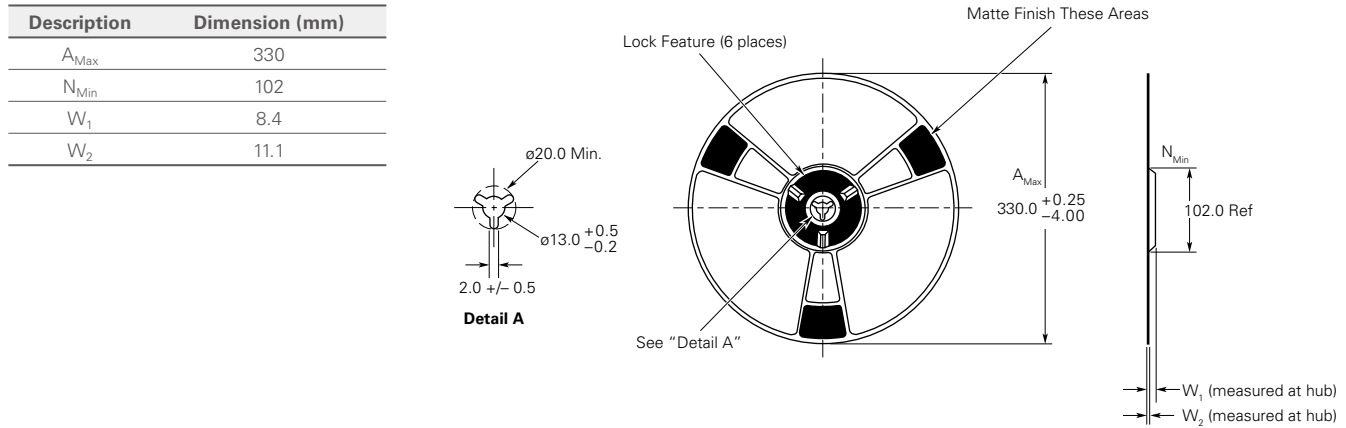

Figure PZ48 – EIA Referenced Taped Component Dimensions for ZENxxxVyyyAzzYM Devices in Millimeters (mm)

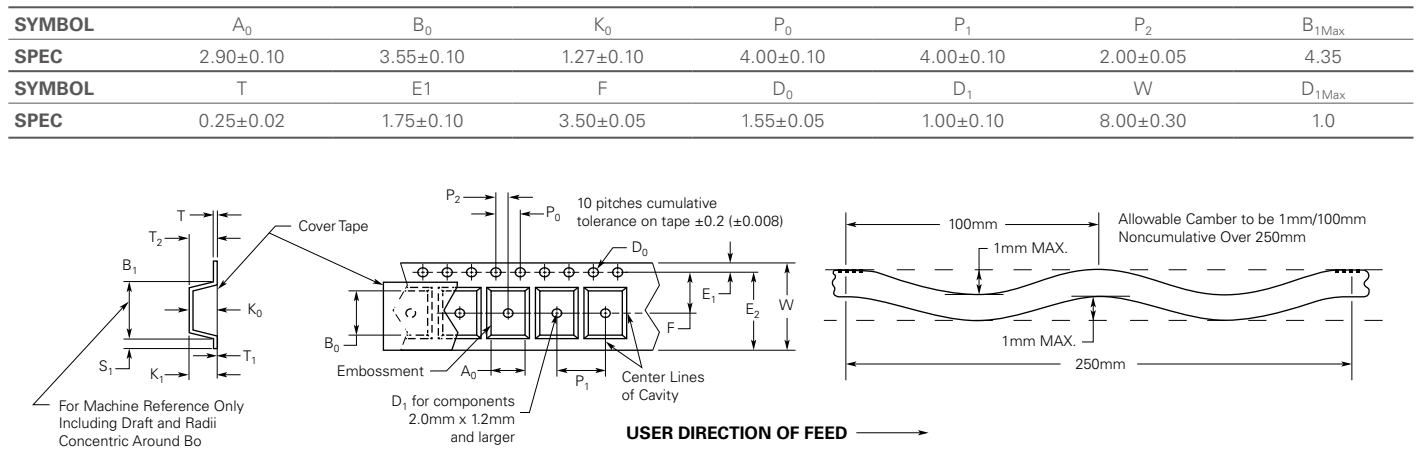
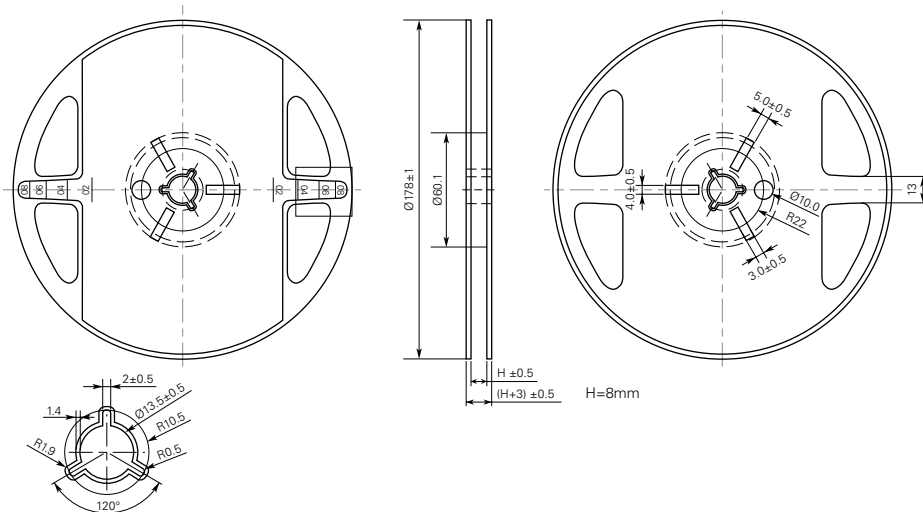

Figure PZ49 – Reel Dimensions for ZENxxxVyyyAzzYM Devices in Millimeters (mm)



4 PolyZen Devices Polymer Protected Zener Diode

Figure PZ50 – EIA Referenced Taped Component Dimensions for ZENxxxVyyyAzzYC Devices in Millimeters (mm)

| Item | Dimension | Tolerance |
|------------------|-----------|----------------|
| W | 12.00 | ±0.10 |
| P | 8.00 | ±0.10 |
| E | 1.75 | ±0.10 |
| F | 5.50 | ±0.10 |
| P ₂ | 2.00 | ±0.10 |
| D | 1.50 | +0.10 -0.00 |
| D ₁ | 1.50 | ±0.10 |
| P ₀ | 4.00 | ±0.10 |
| 10P ₀ | 40.00 | ±0.20 |
| A ₀ | 4.20 | ±0.10 |
| B ₀ | 5.25 | ±0.10 |
| K ₀ | 1.40 | ±0.10 |
| t | 0.24 | ±0.05 |

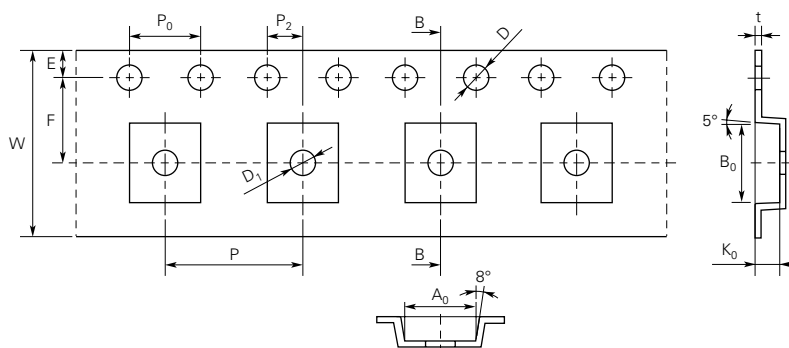
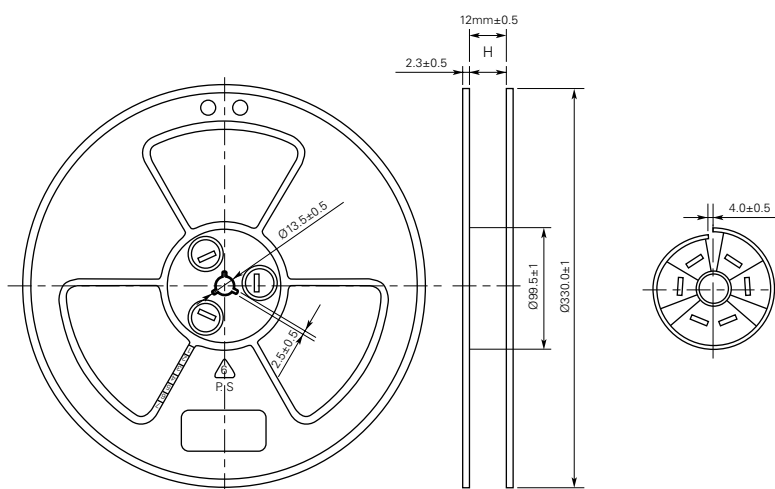

Figure PZ51 – Reel Dimensions for ZENxxxVyyyAzzYC Devices in Millimeters (mm)



Part Numbering System

ZEN 056V 130A 24 LS & YC & YM

Special Labeling

LS = 4.0 * 4.0mm package size typical

YM = 2.5 * 3.2mm package size typical

YC = 4.0 * 5.0mm package size typical

V_{INT} Max Rating (24 = 24V)

PPTC Hold Current Group (130 = 1.3A)

Zener Voltage Group (056 = 5.6V)

PolyZen Series

4

PolyZen Devices Polymer Protected Zener Diode

Part Marking System

ZENxxxVyyyAzzLS Devices

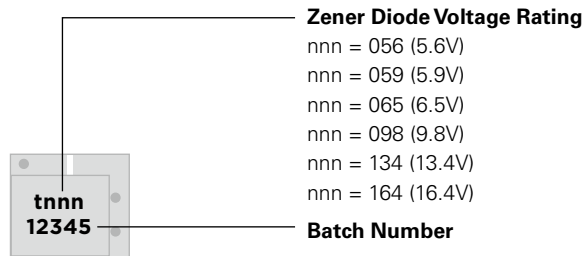

ZENxxxVyyyAzzYM Devices

| Markings | V _z | Hold Current | Special Code | Part Description |
|----------|----------------|--------------|--------------|------------------|
| 0513F | 5.6V | 1.3A | F | ZEN056V130A16YM |
| 0517F | 5.6V | 1.75A | F | ZEN056V175A12YM |
| 1313F | 13.2V | 1.3A | F | ZEN132V130A16YM |
| 1317F | 13.2V | 1.75A | F | ZEN132V175A12YM |

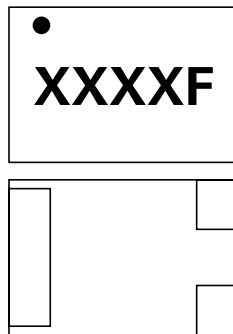

ZENxxxVyyyAzzYC Devices

| Markings | V _z | Hold Current | Special Code | Part Description |
|----------|----------------|--------------|--------------|-------------------------------|
| 0513F | 5.6V | 1.3A | F | ZEN056V130A24YC |
| 052XF | 5.6V | 2.3A | F | ZEN056V230A16YC |
| 052XF | 5.6V | 2.6A | F | ZEN056V230A16YC |
| 1313F | 13.2V | 1.3A | F | ZEN132V130A24YC |
| 132XF | 13.2V | 2.3A | F | ZEN132V230A16YC |
| 132XF | 13.2V | 2.6A | F | ZEN132V230A16YC |
| #### | | | | Last 4 digits of batch number |

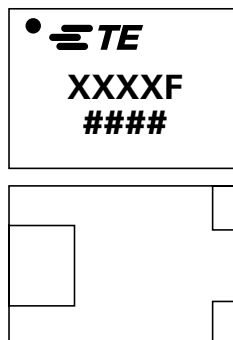

Notice:

Information furnished is believed to be accurate and reliable. However, users should independently evaluate the suitability of and test each product selected for their own applications. Tyco Electronics Corporation and its affiliates in the TE Connectivity Ltd. group of companies ("TE") reserve the right to change or update, without notice, any information contained in this publication; to change, without notice, the design, construction, processing, or specification of any product; and to discontinue or limit production or distribution of any product. This publication supersedes and replaces all information previously supplied. Without express written consent by an officer of TE, TE does not authorize the use of any of its products as components in nuclear facility applications, aerospace, or in critical life support devices or systems. TE expressly disclaims all implied warranties regarding the information contained herein, including, but not limited to, any implied warranties of merchantability or fitness for a particular purpose. TE's only obligations are those in the TE Standard Terms and Conditions of Sale and in no case will TE be liable for any incidental, indirect, or consequential damages arising from the sale, resale, use, or misuse of its products.

Looking for pricing, stock, or lifecycle information?

Click below to explore more details on WIN SOURCE:

 [View ZEN132V130A24YC on WIN SOURCE](#)

 [Littelfuse Inc. Information](#)

Optimize Your Supply Chain with WIN SOURCE Solutions

-  Global Sourcing Solution
-  Obsolete Management
-  Cost Control Management
-  Shortage Management
-  Alternative Solution
-  Excess Inventory Management