



**THE DATASHEET OF  
TPS16416DRCR**



# TPS25762-Q1 Automotive USB Type-C® Power Delivery Controller with Buck-Boost Regulator

## 1 Features

- AEC-Q100 qualified with the following results:
  - Device temperature grade 1: –40°C to +125°C ambient operating temperature range
  - Device HBM ESD classification level 2
  - Device CDM ESD classification level C2b
  - Enhanced connector pin ESD protection
- USB power delivery (PD) controller with programmable power supply (PPS) support
  - Wide  $V_{IN}$ : 5.5V to 18V (40V maximum)
  - Integrated buck-boost with 4 power switches supporting up to 65W USB PD output power
  - $V_{BUS}$  output: 3.3–21V with  $\pm 20$ mV step size
  - $I_{BUS}$  output: 0–3A with  $\pm 50$ mA current limit step size
  - $V_{BUS}$  short circuit to  $V_{BAT}$  and GND protection
  - $V_{BUS}$  cable droop compensation
  - MFi overcurrent protection
  - Switching frequency: 300, 400, 450kHz
  - DC/DC sync in/out with dithering
- USB port configuration options
  - 1 USB-PD port (TPS25762-Q1)
  - 1 USB-PD port with DisplayPort™ over USB-C™ (DP alternate mode) (TPS25763-Q1)
  - 2 USB-PD ports (TPS25772-Q1)
- Compliant to USB
  - USB Type-C® power delivery Rev 3.1
    - TPS25762-Q1: USB-IF certification with PPS, TID: 9509
    - TPS25772-Q1: USB-IF certification with PPS, TID: 9161
    - CC logic,  $V_{CONN}$  source and discharge
    - USB cable polarity detection
  - Battery charging specification v1.2 (BC1.2)
    - DCP: dedicated charging port
- Legacy fast charging
  - 2.7V divider-3 mode
  - 1.2V divider mode
  - high voltage DCP Protocol
- Microcontroller core allows
  - Firmware updates
  - [Supply voltage and temperature-dependent power management](#)
- Short to  $V_{BUS}$  and  $V_{BAT}$  protection
  - $V_{BUS}$
  - $Px\_DP$  and  $Px\_DM$
  - $Px\_CC1$  and  $Px\_CC2$
- HotRod™ QFN package with wettable flank

## 2 Applications

- [Automotive USB Charge](#)
- [Automotive Media Hub](#)
- [Automotive Head Unit](#)
- [Automotive Rear Seat Entertainment](#)

## 3 Description

The TPS25762-Q1 is a fully integrated USB Type-C® Power Delivery (PD) solution with integrated Buck-Boost converter for automotive single USB port applications. Functionality includes: integrated Buck-Boost converter with 4 power switches; an ARM® Cortex®-M0; USB port controller with Type-C cable plug and orientation detection; USB Battery Charging Specification Version 1.2 (BC1.2) detection; USB Endpoint PHY; device power management and supervisory circuitry; and connector pin over-voltage and short-circuit protection.

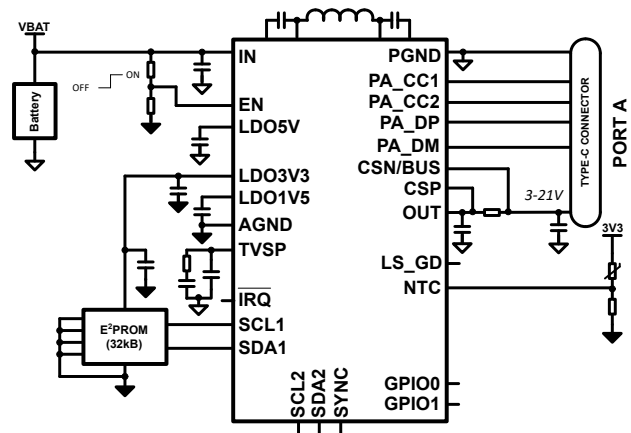
An intelligent System Power Management (SPM) Engine maximizes delivered USB power while protecting the system from automotive battery transient and over-temperature conditions.

Device configuration settings are selected through an intuitive [graphical user interface \(GUI\)](#).

### Package Information

PART NUMBER	PACKAGE <sup>(1)</sup>	PACKAGE SIZE <sup>(2)</sup>
TPS25762-Q1	RQL (QFN-29)	6.00mm × 5.00mm

- (1) For more information, see [Mechanical, Packaging, and Orderable Information](#)
- (2) The package size (length × width) is a nominal value and includes pins, where applicable.



TPS25762-Q1 Simplified Schematic

## Table of Contents

<b>1 Features</b> .....	1	6.17 Typical Characteristics.....	21
<b>2 Applications</b> .....	1	<b>7 Parameter Measurement Information</b> .....	29
<b>3 Description</b> .....	1	<b>8 Detailed Description</b> .....	31
<b>4 Device Comparison Table</b> .....	3	8.1 Overview.....	31
<b>5 Pin Configuration and Functions</b> .....	4	8.2 Functional Block Diagram.....	32
<b>6 Specifications</b> .....	6	8.3 Feature Description.....	32
6.1 Absolute Maximum Ratings.....	6	8.4 Device Functional Modes.....	66
6.2 ESD Ratings .....	7	<b>9 Application and Implementation</b> .....	67
6.3 Recommended Operating Conditions.....	7	9.1 Application Information.....	67
6.4 Recommended Components.....	8	9.2 Typical Application.....	67
6.5 Thermal Information.....	9	9.3 Power Supply Recommendations.....	81
6.6 Buck-Boost Regulator.....	9	9.4 Layout.....	81
6.7 CC Cable Detection Parameters.....	13	<b>10 Device and Documentation Support</b> .....	83
6.8 CC VCONN Parameters.....	13	10.1 Documentation Support.....	83
6.9 CC PHY Parameters.....	14	10.2 Receiving Notification of Documentation Updates..	83
6.10 Thermal Shutdown Characteristics.....	15	10.3 Support Resources.....	83
6.11 Oscillator Characteristics.....	15	10.4 Trademarks.....	83
6.12 ADC Characteristics.....	16	10.5 Electrostatic Discharge Caution.....	83
6.13 TVSP Parameters.....	16	10.6 Glossary.....	83
6.14 Input/Output (I/O) Characteristics.....	17	<b>11 Revision History</b> .....	83
6.15 BC1.2 Characteristics.....	18	<b>12 Mechanical, Packaging, and Orderable Information</b> .....	85
6.16 I2C Requirements and Characteristics.....	18		

## 4 Device Comparison Table

PART NUMBER	Orderable Device	Port A	Port B	Port A Output Power	Port B Output Power	DP Alternate Mode	Astable VIN Boot Support	Configurable Boot Mode <sup>(2)</sup>
TPS25762-Q1	TPS25762CQRQLRQ1		n/a	65 W	n/a	No	VIN-dependent <sup>(1)</sup>	Yes
	TPS25762CAQRQLRQ1						Yes	No
	TPS25762DQRQLRQ1						Yes	Yes
TPS25772-Q1	TPS25772CQRQLRQ1	USB-PD	USB-PD	65 W	65 W	No	VIN-dependent <sup>(1)</sup>	Yes
	TPS25772CAQRQLRQ1						Yes	No
	TPS25772DQRQLRQ1						Yes	Yes
TPS25763-Q1	TPS25763DQRQLRQ1		n/a		n/a	Yes	Yes	Yes

1. Assured device boot up during a stable VIN (for example, cold crank) conditions when VIN oscillation minimum voltage is  $\geq 7.6V$  until boot is completed. Refer to application brief [TPS257x2-Q1 Startup with an Astable Supply Voltage](#).
2. Refer to [Section 8.3.2](#).

## 5 Pin Configuration and Functions

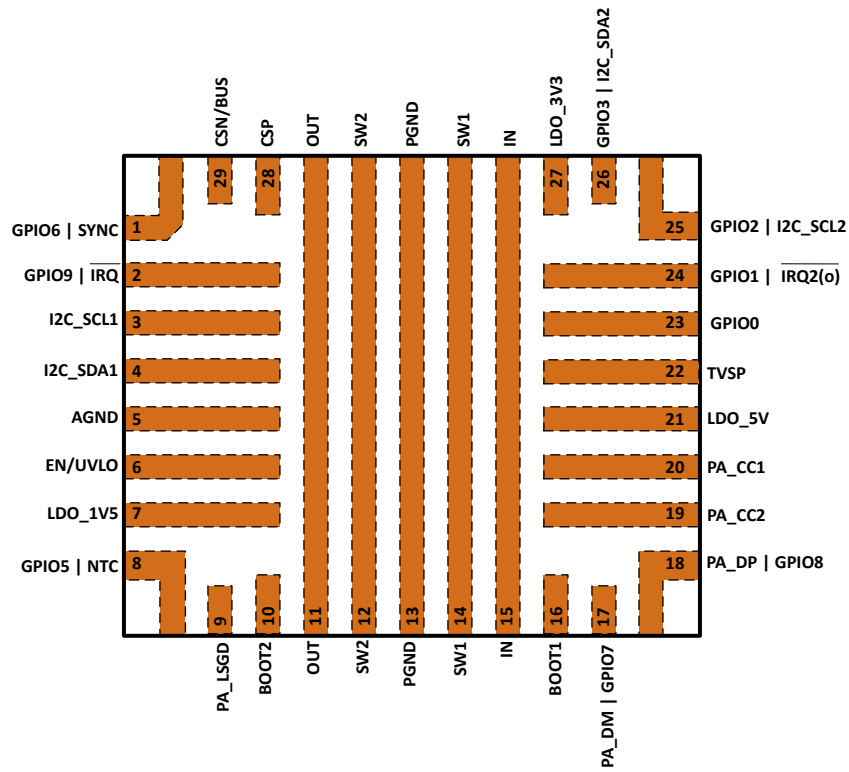


Figure 5-1. RQL Package 29-Pin (VQFN) Top View

**Table 5-1. Pin Descriptions**

PIN		DESCRIPTION
NAME	NO.	
EN/UVLO	6	Enable pin. For EN/UVLO < 0.3 V, the TPS25762-Q1 is in a low current shutdown mode. For EN/UVLO > 1.3 V, the full functionality is enabled, provided LDO_5V exceeds the LDO_5V UVLO threshold.
IN	15	The input supply pin to the IC. Connect V <sub>IN</sub> to a supply voltage between 5.5 V and 18 V (40-V ABS MAX transient).
PGND	13	Power ground of the IC. The high current ground connection to the low-side gate drivers.
SW1	14	The buck side switching node.
SW2	12	The boost side switching node.
BOOT1	16	An external capacitor is required between the BOOT1 and the SW1 pins to provide bias to the high-side MOSFET gate drivers.
BOOT2	10	An external capacitor is required between the BOOT2 and the SW2 pins to provide bias to the high-side MOSFET gate drivers.
AGND	5	Analog ground of the IC.
OUT	11	Output of the buck-boost regulator. Connect to bulk capacitance.
CSP	28	Positive input of the current sense amplifier.
CSN/BUS	29	Negative input of the current sense amplifier. This is the PA_VBUS supply.
LDO_5V	21	Output of internal 5 V LDO for buck-boost low-side FET drivers, and Px_VCONN supply. Connect bypass capacitor to PGND. May be overdriven from external 5-V supply.
LDO_3V3	27	Output of internal 3.3-V LDO for analog circuitry and GPIO drivers. Connect bypass capacitor to AGND.
LDO_1V5	7	Output of internal 1.5-V LDO for digital circuitry. Connect bypass capacitor to AGND.
I2C_SCL1	3	Controller I2C Clock Input/Output.
I2C_SDA1	4	Controller I2C Data Input/Output.
GPIO2 (I2C_SCL2)	25	Multifunction pin. GPIO; or target I2C Clock Input.
GPIO3 (I2C_SDA2)	26	Multifunction pin. GPIO; or target I2C Data Input.
IRQ (GPIO9)	2	Multifunction pin. Interrupt I/O and fault flag for I2C1 or I2C2; or GPIO depending upon firmware configuration. Reports fault conditions set by application configuration firmware.
PA_CC1	20	Analog input/output. Port A Type-C current advertisement, VCONN, and USB PD modem. Connect to Port A Type-C connector CC1 pin.
PA_CC2	19	Analog input/output. Port A Type-C current advertisement, VCONN, and USB PD modem. Connect to Port A Type-C connector CC2 pin.
PA_DP (GPIO8)	18	Multifunction pin. BC1.2 USB 2.0 D+ data line input/output. Connect to Port A Type-C USB data line DP connector pins. May also be used as GPIO depending upon firmware configuration.
PA_DM (GPIO7)	17	Multifunction pin. BC1.2 USB 2.0 D- data line input/output. Connect to Port A Type-C USB data line DM connector pins. May also be used as GPIO depending upon firmware configuration.
GPIO0	23	GPIO
GPIO1 or IRQ2(o)	24	Multifunction pin. GPIO or Interrupt I/O depending upon firmware configuration.
GPIO5 (NTC)	8	Multifunction pin. GPIO; thermistor input (can use either negative temperature coefficient resistor or positive temperature coefficient resistor).
GPIO6 (SYNC)	1	Multifunction pin. GPIO; SYNC(o) - clock out to synchronize external DC/DC regulators to internal DC/DC switching frequency; SYNC(i) - clock input to synchronize internal DC/DC to an external clock.
PA_LSGD	9	Charge pump output for external NFET for V <sub>BUS</sub> bulk capacitance blocking.
TVSP	22	Transient voltage protection and firmware setting pin. See <a href="#">TVSP Device Configuration and ESD Protection</a> for boot configuration and R-C network component values.

## 6 Specifications

### 6.1 Absolute Maximum Ratings

Over the recommended operating junction temperature range of -40°C to 150°C and AGND = PGND (unless otherwise noted)<sup>(1) (2)</sup>

		MIN	MAX	UNIT
Input voltage range	IN <sup>(3) (4)</sup> to PGND	-0.3	40	V
Input voltage range	IN with respect to SW1	-0.3	25	V
Input voltage range	EN/UVLO <sup>(5)</sup> to AGND	-0.3	internally limited	V
Input voltage range	BOOT1 with respect to SW1	-0.3	6	V
Input voltage range	BOOT2 with respect to SW2 <sup>(6)</sup>	-0.3	6	V
Input voltage range	SW1 <sup>(7)</sup> to PGND	-0.3	24	V
Input voltage range	SW2 <sup>(8)</sup> to PGND	-0.3	24	V
Input voltage range	SW2 to OUT		17.5	V
Input voltage range	CSP to PGND	-0.3	24	V
Input voltage range	CSN/BUS to PGND	-0.3	24	V
Input voltage range	CSP to CSN	-0.3	0.3	V
Input voltage range	AGND to PGND	-0.3	0.3	V
Output voltage range	OUT to PGND	-0.3	24	V
Output voltage range	LDO_5V to PGND	-0.3	6	V
Output voltage range	LDO_3V3 to AGND	-0.3	6	V
Output voltage range	LDO_1V5 to AGND	-0.3	2	V
I/O voltage range	TVSP to PGND	-0.3	30	V
I/O voltage range	I2C_SCL1 to AGND	-0.3	6	V
I/O voltage range	I2C_SDA1 to AGND	-0.3	6	V
I/O voltage range	GPIO9, $\overline{\text{IRQ1}}$ to AGND	-0.3	6	V
I/O voltage range	PA_CC1 to AGND	-0.3	30	V
I/O voltage range	PA_CC2 to AGND	-0.3	30	V
I/O voltage range	PA_DM to AGND	-0.3	30	V
I/O voltage range	GPIO7 to AGND	-0.3	6	V
I/O voltage range	PA_DP to AGND	-0.3	30	V
I/O voltage range	GPIO8 to AGND	-0.3	6	V
I/O voltage range	GPIO0 to AGND	-0.3	6	V
I/O voltage range	GPIO1, $\overline{\text{IRQ2}}$ to AGND	-0.3	6	V
I/O voltage range	GPIO2, I2C_SCL2 to AGND	-0.3	6	V
I/O voltage range	GPIO3, I2C_SDA2 to AGND	-0.3	6	V
I/O voltage range	PA_LSGD to PGND	-0.3	30	V
I/O voltage range	GPIO5, NTC to AGND	-0.3	6	V
I/O voltage range	GPIO6, SYNC to AGND	-0.3	6	V
I/O voltage range	PA_LSGD to CSN/BUS	-0.3	10	V

## 6.1 Absolute Maximum Ratings (continued)

Over the recommended operating junction temperature range of -40°C to 150°C and AGND = PGND (unless otherwise noted)<sup>(1) (2)</sup>

		MIN	MAX	UNIT
Input current	EN/UVLO	0	2	mA
Output current	Positive source current on PA_CC1, PA_CC2	internally limited		A
Output current	GPIO 2, 3, 5, 6, 7, 8	0.0010		A
Output current	GPIO 0, 1, 4, 9	0.005		A
Output current	positive sink current for I2C_SDA1, I2C_SCL1, I2C_SDA2, I2C_SCL2	internally limited		A
Output current	positive source current for LDO_5V, LDO_3V3, LDO_1V5	internally limited		A
T <sub>A</sub> Operating ambient temperature		-40	125	°C
T <sub>J</sub> Operating junction temperature		-40	150	°C
T <sub>STG</sub> Storage temperature		-55	150	°C

- Operation outside the Absolute Maximum Ratings may cause permanent device damage. Absolute Maximum Ratings do not imply functional operation of the device at these or any other conditions beyond those listed under Recommended Operating Conditions. If used outside the Recommended Operating Conditions but within the Absolute Maximum Ratings, the device may not be fully functional, and this may affect device reliability, functionality, performance, and shorten the device lifetime.
- All voltage values are with respect to PGND or AGND. Connect the PGND pin directly to the Ground plane of the board. The PGND and AGND traces can be connected near the AGND pin.
- When the buck-boost is operating and V<sub>IN</sub> exceeds 18 V, the positive slew rate dV<sub>IN</sub>/dt must not exceed 200V/ms.
- When applying V<sub>IN</sub>, the time from V<sub>IN</sub> exceeding 5 V to V<sub>IN</sub> exceeding 25 V must not be less than 2 μs and can be achieved by properly sizing the input EMI filter.
- EN/UVLO pin is internally clamped to 10V. Ensure input current rating is not exceeded by connecting current limit resistor.
- BOOT2 with respect to SW2 during OUT overvoltage conditions can be -15 V due to internal clamp.
- SW1 can undershoot PGND by -1 V during negative switching transients as up to 10A (peak) may flow through the body diode. Typical duration ~20 ns. SW1 can overshoot OUT by 1 V during positive transients. Typical duration ~ 20 ns.
- SW2 can undershoot PGND by -2 V during switching transients as up to 10A (peak) may flow through the body diode. Typical duration ~20 ns. SW2 can overshoot OUT by 1 V during positive transients. Typical duration ~20 ns.

## 6.2 ESD Ratings

			VALUE	UNIT	
V <sub>(ESD)</sub>	Electrostatic discharge	Human-body model (HBM), per AEC Q100-002	±2000 <sup>(1)</sup>	V	
V <sub>(ESD)</sub>	Electrostatic discharge	Charged-device model (CDM), per AEC Q100-011	±750 <sup>(2)</sup>	V	
V <sub>(ESD)</sub>	Electrostatic discharge	IEC61000-4-2 Contact discharge 150 pF, 330 Ω.	OUT, CSP, CSN/BUS, PA_CC1, PA_CC2, PA_DP, PA_DM	±2000 <sup>(3)</sup>	V
V <sub>(ESD)</sub>	Electrostatic discharge	IEC61000-4-2 Contact discharge 150 pF, 330 Ω.	OUT, CSP, CSN/BUS, PA_CC1, PA_CC2, PA_DP, PA_DM	±2000 <sup>(3)</sup>	V
V <sub>(ESD)</sub>	Electrostatic discharge	ISO 10605 Contact discharge 330 pF, 330 Ω.	OUT, CSP, CSN/BUS, PA_CC1, PA_CC2, PA_DP, PA_DM	±2000 <sup>(3)</sup>	V
V <sub>(ESD)</sub>	Electrostatic discharge	ISO 10605 Air-gap discharge 330 pF, 330 Ω.	OUT, CSP, CSN/BUS, PA_CC1, PA_CC2, PA_DP, PA_DM	±2000 <sup>(3)</sup>	V

- AEC Q100-002 indicates that HBM stressing shall be in accordance with the ANSI/ESDA/JEDEC JS-001 specification.
- The passing level per AEC-Q100 Classification C2b.
- Test conducted on Texas Instruments evaluation board.

## 6.3 Recommended Operating Conditions

Over the recommended operating junction temperature range of -40°C to 150°C (unless otherwise noted)

			MIN	MAX	UNIT
V <sub>I</sub>	Input voltage range (up to 65W output)	IN	6.8	18	V
V <sub>I</sub>	Input voltage range (up to 30W output)	IN	5.5	18	V
V <sub>I</sub>	Input voltage range	EN/UVLO	0	7 <sup>(2)</sup>	V

### 6.3 Recommended Operating Conditions (continued)

Over the recommended operating junction temperature range of -40°C to 150°C (unless otherwise noted)

			MIN	MAX	UNIT
$I_I$	Input current	EN/UVLO	0	1	mA
$V_I$	Input voltage range	LDO_5V when overdriven by external supply	4.75	5.5	V
$V_I$	Input voltage range	CSP, CSN/BUS	0	22	V
$V_I$	Input voltage range	PB_VBUS (GPIO4 when configured as PB_VBUS)	3	22	V
$V_O$	Output voltage range	OUT	0	21	V
$V_{IO}$	I/O voltage range	PA_CC1, PA_CC2, PB_CC1, PB_CC2	0	5.5	V
$V_{IO}$	I/O voltage range	PA_DP, PA_DM, PB_DP, PB_DM	0	3.6	V
$V_{IO}$	I/O voltage range	I2C_SDA <sub>n</sub> , I2C_SCL <sub>n</sub> , I <sup>RQ</sup> <sub>n</sub> (n=1 or 2)	0	5.5	V
$V_{IO}$	I/O voltage range	GPIO <sub>n</sub> (n = 0 - 9)	0	3.6	V
$V_{IO}$	I/O voltage range	NTC monitor (GPIO5), SYNC (GPIO6)	0	3.6	V
$I_O$	Output current <sup>(1)</sup>	IOUT		5	A
$I_O$	Output current	PA_CC1, PA_CC2, PB_CC1, PB_CC2		225	mA
$I_O$	Output current (from LDO_3V3)	GPIO <sub>n</sub> (n = 0 - 9)		10	mA
fsw	Buck-boost converter switching frequency driven from SYNC pin		250	500	kHz
$T_A$	Ambient operating temperature		-40	125	°C
$T_J$	Operating junction temperature		-40	150	°C

- (1) Average LC filtered output current from buck-boost power stage. Operation with  $I_{OUT} > 3A$  with  $V_{OUT} > 10V$  may result in thermal shutdown.
- (2) EN/UVLO MAX specification applies when current into pin is not externally limited.

### 6.4 Recommended Components

over operating free-air temperature range (unless otherwise noted)

PARAMETER <sup>(1)</sup>		VOLTAGE RATING	MIN	TYP	MAX	UNIT
$C_{IN}$	Capacitance on VIN	40 V	22	47		μF
$C_{LDO\_5V}$	Capacitance on LDO_5V (supplied internally)	10 V	4.7		10	μF
$C_{LDO\_5V}$	Capacitance on LDO_5V (supplied externally)	10 V	10	47	100	μF
$C_{LDO\_3V3}$	Capacitance on LDO_3V3	6.3 V	4.7		10	μF
$C_{LDO\_1V5}$	Capacitance on LDO_1V5	6.3 V	4.7		10	μF
$C_{Px\_CCy}$	Capacitance on Px_CCy pins <sup>(2)</sup>	6.3 V	200	330	480	pF
$C_{BOOT1}, C_{BOOT2}$	Boot charge capacitance	10 V	0.08	0.1	0.3	μF
$R_{S\text{nubber\_SW1}}$	RC snubber resistor on SW1	35 V, 0.25 W		1.1		Ω
$C_{S\text{nubber\_SW1}}$	RC snubber capacitor on SW1	35 V		1		nF
$R_{S\text{nubber\_SW2}}$	RC snubber resistor on SW2	35 V, 0.25 W		1.1		Ω
$C_{S\text{nubber\_SW2}}$	RC snubber capacitor on SW2	35 V		3.3		nF
$C_{OUT}$	Capacitance on OUT <sup>(4)</sup>	35 V	30	33	40	μF
$C_{BUS}$	Capacitance on PA_VBUS	35 V	100	120	150	μF
L	Inductor <sup>(4)</sup>		3.3	4.7	5.6	μH
NTC	Thermistor		47		100	kΩ

## 6.4 Recommended Components (continued)

over operating free-air temperature range (unless otherwise noted)

PARAMETER <sup>(1)</sup>		VOLTAGE RATING	MIN	TYP	MAX	UNIT
R <sub>EN/UVLO</sub>	Enable/UVLO pull up resistance		47			kΩ
TVPS pin components (C <sub>TVSP</sub>    (Damper <sub>R</sub> + C))	C <sub>TVSP</sub> Capacitance on TVSP pin <sup>(3)</sup>	40 V	0.08	0.1	0.12	μF
TVPS pin components (C <sub>TVSP</sub>    (Damper <sub>R</sub> + C))	Damper resistor R of R + C network in Parallel with C <sub>TVSP</sub>	0.25W	8	10	12	Ω
TVPS pin components (C <sub>TVSP</sub>    (Damper <sub>R</sub> + C))	Damper capacitor C of R + C network in Parallel with C <sub>TVSP</sub>	40 V	0.376	0.47	0.564	μF
ESR <sub>CTVSP</sub>	TVSP Capacitor ESR (eq series resistance)			10		mΩ
ESL <sub>CTVSP</sub>	TVSP Capacitor ESL (eq series inductance)			1		nH

- (1) Capacitance values do not include any derating factors. For example, if 5.0 μF is required and the external capacitor value reduces by 50% at the required operating voltage, then the required external capacitor value is 10 μF.
- (2) This includes all capacitance to the Type-C receptacle.
- (3) Maximum capacitance allowed on TVSP pin to ensure proper decode of device configuration during boot.
- (4) See applications section for recommended L and C<sub>OUT</sub> combinations.

## 6.5 Thermal Information

THERMAL METRIC <sup>(1)</sup>		TPS25762-Q1	UNIT
		Hot Rod	
		29 PINS	
R <sub>θJA</sub>	Junction-to-ambient thermal resistance	33.3	°C/W
R <sub>θJC(top)</sub>	Junction-to-case (top) thermal resistance	13.1	
R <sub>θJB</sub>	Junction-to-board thermal resistance	7.3	
ψ <sub>JT</sub>	Junction-to-top characterization parameter	0.3	
ψ <sub>JB</sub>	Junction-to-board characterization parameter	7.2	

- (1) For more information about traditional and new thermal metrics, see the [Semiconductor and IC Package Thermal Metrics](#) application report.

## 6.6 Buck-Boost Regulator

Typical values correspond to T<sub>J</sub> = 25°C. Minimum and maximum limits apply over the –40°C to 150°C junction temperature range unless otherwise stated. V<sub>IN</sub> = 13.5 V, V<sub>EN/UVLO</sub> = 2V unless otherwise stated. <sup>(1)</sup>

PARAMETER	TEST CONDITION	MIN	TYP	MAX	UNIT	
<b>SUPPLY VOLTAGE (VIN)</b>						
I <sub>Q</sub>	V <sub>IN</sub> shutdown current	V <sub>EN/UVLO</sub> = 0 V		130	μA	
I <sub>Q</sub>	V <sub>IN</sub> operating current	V <sub>EN/UVLO</sub> = 2V, V <sub>OUT</sub> = 5 V, I <sub>OUT</sub> = 0 A	8		mA	
I <sub>Q</sub>	V <sub>IN</sub> operating current	V <sub>EN/UVLO</sub> = 1V, V <sub>OUT</sub> = 0 V, I <sub>OUT</sub> = 0 A		4.5	mA	
I <sub>Q</sub>	V <sub>IN</sub> operating current	V <sub>EN/UVLO</sub> = 2V, V <sub>OUT</sub> = 0 V, I <sub>OUT</sub> = 0 A		8	mA	
V <sub>IN(OVP_R)</sub>	V <sub>IN</sub> rising overvoltage threshold	V <sub>IN</sub> rising.	18.4	19.2	20	V
V <sub>IN(OVP_F)</sub>	V <sub>IN</sub> falling overvoltage threshold	V <sub>IN</sub> falling.	18.0	18.8	19.6	V
	hysteresis		0.4			V
V <sub>IN(UVLO_R)</sub>	V <sub>IN</sub> undervoltage lockout rising	V <sub>IN</sub> rising.	5.14	5.30	5.46	V
V <sub>IN(UVLO_F)</sub>	V <sub>IN</sub> undervoltage lockout falling	V <sub>IN</sub> falling.	5.04	5.20	5.36	V
	hysteresis		0.1			V
<b>LDO_5V OUTPUT</b>						
V <sub>LDO_5V</sub>	LDO_5V Output Regulation voltage	7V ≤ V <sub>IN</sub> ≤ 18 V, 0 < I <sub>LDO_5V</sub> < 125mA, V <sub>EN</sub> = 2 V.	4.5	4.63	4.75	V
V <sub>LDO_5V(UVLO_R)</sub>	LDO_5V Undervoltage lockout rising		4.29	4.4	4.51	V

## 6.6 Buck-Boost Regulator (continued)

Typical values correspond to  $T_J = 25^\circ\text{C}$ . Minimum and maximum limits apply over the  $-40^\circ\text{C}$  to  $150^\circ\text{C}$  junction temperature range unless otherwise stated.  $V_{IN} = 13.5\text{ V}$ ,  $V_{EN/UVLO} = 2\text{ V}$  unless otherwise stated. <sup>(1)</sup>

PARAMETER		TEST CONDITION	MIN	TYP	MAX	UNIT
$V_{LDO\_5V(UVLO\_F)}$	LDO_5V Undervoltage lockout falling		4.09	4.2	4.31	V
	Undervoltage hysteresis			200		mV
$V_{LDO\_5V\_DO}$	drop out voltage	$V_{IN} = 5.5\text{ V}$ ; $I_{LDO\_5V} = 125\text{ mA}$	4.3			V
$I_{LDO\_5V(ILIMIT)}$	LDO_5V current limit	$V_{LDO\_5V} = 0$ to $3.5\text{ V}$ , $R_{LDO\_5V\_LOAD} = 1\ \Omega$	125	200	400	mA
<b>LDO_3V3 OUTPUT</b>						
$V_{LDO\_3V3}$	LDO_3V3 Output regulation voltage	$7\text{ V} \leq V_{IN} \leq 18\text{ V}$ , $V_{EN} = 2\text{ V}$ , $V_{LDO\_5V(UVLO)} < V_{LDO\_5V} < 5.5\text{ V}$ , $0 < I_{LDO\_3V3} < 25\text{ mA}$	3.4	3.5	3.6	V
$V_{LDO\_3V3(UVLO\_R)}$	LDO_3V3 Undervoltage lockout rising		3.2	3.3	3.4	V
$V_{LDO\_3V3(UVLO\_F)}$	LDO_3V3 Undervoltage lockout falling		3.05	3.15	3.25	V
	Undervoltage hysteresis			150		mV
$V_{LDO\_3V3\_DO}$	drop out voltage	$V_{IN} = 4.5\text{ V}$ , $I_{LDO\_3V3} = 30\text{ mA}$	3.3			V
$I_{LDO\_3V3(ILIMIT)}$	LDO_3V3 current limit	$V_{LDO\_3V3} = 0$ to $2.5\text{ V}$ , $R_{LDO\_3V3\_LOAD} = 1\ \Omega$	35	50	80	mA
<b>LDO_1V5 OUTPUT</b>						
$V_{LDO\_1V5}$	LDO_1V5 Output Regulation voltage	$4.5 < V_{LDO\_5V} < 5.5\text{ V}$ , $0 < I_{LDO\_1V5} < 10\text{ mA}$	1.49	1.55	1.65	V
$V_{LDO\_1V5(UVLO\_R)}$	LDO_1V5 Undervoltage lockout rising		1.44	1.49	1.54	V
$V_{LDO\_1V5(UVLO\_F)}$	LDO_1V5 Undervoltage lockout falling		1.37	1.42	1.47	V
	Undervoltage hysteresis			70		mV
$I_{LDO\_1V5(ILIMIT)}$	LDO_1V5 current limit	$V_{LDO\_1V5} = 0$ to $1.2\text{ V}$ , $R_{LDO\_1V5\_LOAD} = 1\ \Omega$	15	20	28	mA
<b>EN/UVLO</b>						
$V_{EN(LDO\_V5V\_R)}$	EN input level required to turn on internal LDOs	EN/UVLO rising			1.05	V
$V_{EN(LDO\_V5V\_F)}$	EN input level required to turn off internal LDOs	EN/UVLO falling	0.3			V
$V_{EN(OPER)}$	EN input level required to start operation	EN/UVLO rising Precision EN	1.2	1.25	1.3	V
$V_{EN(STBY)}$	EN input level required to stop operation	EN/UVLO falling	1.1	1.15	1.2	V
$V_{EN(HYS)}$	Hysteresis			100		mV
$V_{EN(CLAMP)}$	EN input clamp voltage	$V_{EN/UVLO} > V_{EN(CLAMP)}$ , $10\ \mu\text{A} < I_{EN/UVLO} < 1\text{ mA}$	6	9	12	V
$I_{EN(LEAK)}$	Leakage current into EN pin	$0\text{ V} < V_{EN} < 6\text{ V}$			1	$\mu\text{A}$
<b>OUTPUT VOLTAGE</b>						
$V_{CSN/BUS(3V)}$	$V_{CNS/BUS}$ regulation accuracy at 3V	$0 \leq I_{OUT} \leq 3\text{ A}$	2.9	3	3.1	V
$V_{CSN/BUS(5V)}$	$V_{CNS/BUS}$ regulation accuracy at 5V	$0 \leq I_{OUT} \leq 3\text{ A}$	4.85	5	5.15	V
$V_{CSN/BUS(21V)}$	$V_{CNS/BUS}$ regulation accuracy at 21V	$0 \leq I_{OUT} \leq 3\text{ A}$	20.48	21	21.53	V
$V_{CSN/BUS\_STP}$	Output voltage step size (12-bit DAC)			10		mV
VDAC Resolution	Resolution of $V_{BUS}$ DAC			12		Bits
$I_{DISCHG}$	CSN/BUS discharge current when transitioning to VSafe0V	$V_{CSP} = V_{CSN/BUS}$ , $V_{CNS/BUS} = 3\text{ V}$ . Measure current into BUS.	40			mA
$t_{DISCHG}$	CSN/BUS discharge time when transitioning to VSafe5V	$V_{BUS} = 21\text{ V}$ (max), $C_{BULK} = 220\ \mu\text{F}$ , time to discharge BUS to $< 5.5\text{ V}$ (per USB PD specification)			275	ms

## 6.6 Buck-Boost Regulator (continued)

Typical values correspond to  $T_J = 25^\circ\text{C}$ . Minimum and maximum limits apply over the  $-40^\circ\text{C}$  to  $150^\circ\text{C}$  junction temperature range unless otherwise stated.  $V_{IN} = 13.5\text{ V}$ ,  $V_{EN/UVLO} = 2\text{ V}$  unless otherwise stated. <sup>(1)</sup>

PARAMETER		TEST CONDITION	MIN	TYP	MAX	UNIT
$t_{DISCHG}$	CSN/BUS discharge time when transitioning to VSafe0V	$V_{BUS} = 21\text{ V (max)}$ , $C_{BULK} = 220\ \mu\text{F}$ , time to discharge BUS to $< 0.8\text{ V}$ (per USB PD specification)			650	ms
$R_{DISCHG}$	Weak discharge resistance on BUS pin when not sourcing VBUS	$EN = 2\text{ V}$ ; measure BUS to PGND resistance.	60		135	k $\Omega$
$R_{BUS-GND(PWR)}$	BUS to GND resistance, $R_{DISCH}$ disabled, not sourcing VBUS	$EN = 2\text{ V}$ measure BUS to PGND resistance.	120		500	k $\Omega$
$R_{BUS-GND(UNPWR)}$	BUS to GND resistance, unpowered	$V_{IN} = EN = 0\text{ V}$ measure BUS to PGND resistance.		2		k $\Omega$
<b>CABLE VOLTAGE DROP COMPENSATION</b>						
$V_{OUT\_CDC}$	$\Delta V_{OUT}$ increase vs $I_{OUT}$	Gain setting = $0.1\text{ V/A}$ : $V_{CSP} - V_{CSN/BUS} = 50\text{ mV}$	465	500	535	mV
$V_{OUT\_CDC}$	$\Delta V_{OUT}$ increase vs $I_{OUT}$	Gain setting = $0.1\text{ V/A}$ : $V_{CSP} - V_{CSN/BUS} = 10\text{ mV}$	85	100	115	mV
$V_{OUT\_CDC}$	$\Delta V_{OUT}$ increase vs $I_{OUT}$	Gain setting = $0.075\text{ V/A}$ : $V_{CSP} - V_{CSN/BUS} = 50\text{ mV}$	346	375	404	mV
$V_{OUT\_CDC}$	$\Delta V_{OUT}$ increase vs $I_{OUT}$	Gain setting = $0.075\text{ V/A}$ : $V_{CSP} - V_{CSN/BUS} = 10\text{ mV}$	61	75	89	mV
$V_{OUT\_CDC}$	$\Delta V_{OUT}$ increase vs $I_{OUT}$	Gain setting = $0.05\text{ V/A}$ : $V_{CSP} - V_{CSN/BUS} = 50\text{ mV}$	227	250	273	mV
$V_{OUT\_CDC}$	$\Delta V_{OUT}$ increase vs $I_{OUT}$	Gain setting = $0.05\text{ V/A}$ : $V_{CSP} - V_{CSN/BUS} = 10\text{ mV}$	37	50	63	mV
$V_{OUT\_CDC}$	$\Delta V_{OUT}$ increase vs $I_{OUT}$	Gain setting = $0.025\text{ V/A}$ : $V_{CSP} - V_{CSN/BUS} = 50\text{ mV}$	109	125	141	mV
$V_{OUT\_CDC}$	$\Delta V_{OUT}$ increase vs $I_{OUT}$	Gain setting = $0.025\text{ V/A}$ : $V_{CSP} - V_{CSN/BUS} = 10\text{ mV}$	14	25	36	mV
$V_{OUT\_CDC}$	$\Delta V_{OUT}$ increase vs $I_{OUT}$	Gain setting = $0\text{ V/A}$ : $0\text{ mV} \leq V_{CSP} - V_{CSN/BUS} \leq 50\text{ mV}$	-5		20	mV
<b>BUCK-BOOST PEAK CURRENT LIMITS</b>						
$I_{PEAK(BOOST)}$	Boost peak current limit (in boost mode)		12.3	14.5	16.7	A
$I_{PEAK(BOOST)}$	Boost peak current limit (in boost mode)		10.8	12.8	14.7	A
$I_{PEAK(BOOST)}$	Boost peak current limit (in boost mode)		9.3	11.0	12.6	A
$I_{PEAK(BOOST)}$	Boost peak current limit (in boost mode)		7.9	9.3	10.6	A
$I_{PEAK(BOOST)}$	Boost peak current limit (in boost mode)		6.3	7.5	8.6	A
$I_{PEAK(BOOST)}$	Boost peak current limit (in boost mode)		4.8	5.7	6.5	A
$I_{PEAK(BUCK)}$	Buck peak current limit (in buck mode)		8.2	9.7	11.2	A
$I_{PEAK(BUCK)}$	Buck peak current limit (in buck mode)		9.0	10.6	12.1	A
$I_{PEAK(BUCK)}$	Buck peak current limit (in buck mode)		9.7	11.4	13.1	A
$I_{PEAK(BUCK)}$	Buck peak current limit (in buck mode)		10.4	12.3	14.1	A
$I_{PEAK(BUCK)}$	Buck peak current limit (in buck mode)		5.3	6.2	7.2	A
$I_{PEAK(BUCK)}$	Buck peak current limit (in buck mode)		6	7.1	8.2	A
$I_{PEAK(BUCK)}$	Buck peak current limit (in buck mode)		6.8	8.0	9.1	A
$I_{PEAK(BUCK)}$	Buck peak current limit (in buck mode)		7.5	8.8	10.1	A

## 6.6 Buck-Boost Regulator (continued)

Typical values correspond to  $T_J = 25^\circ\text{C}$ . Minimum and maximum limits apply over the  $-40^\circ\text{C}$  to  $150^\circ\text{C}$  junction temperature range unless otherwise stated.  $V_{IN} = 13.5\text{ V}$ ,  $V_{EN/UVLO} = 2\text{ V}$  unless otherwise stated. <sup>(1)</sup>

PARAMETER		TEST CONDITION	MIN	TYP	MAX	UNIT
$I_{NEG(BUCK)}$	Buck negative current limit (in buck mode)		-4.6	-3.8	-3	A
<b>OUT CURRENT DAC</b>						
IDAC_Resolution				8		Bits
<b>CURRENT LIMIT</b>						
$I_{LIMIT\_LO}$	Current limit accuracy	$1\text{ A} \leq I_{OUT} \leq 3\text{ A}$ , $V_{CSN/BUS} < 2.5\text{ V}$ ; $R_S = 10\text{ m}\Omega$ .	-250		250	mA
$I_{LIMIT\_LO}$	Current limit accuracy < 1 A	$1\text{ A} \leq I_{OUT} \leq 3\text{ A}$ , $V_{CSN/BUS} \geq 2.5\text{ V}$ ; $R_S = 10\text{ m}\Omega$	-150		150	mA
$I_{LIMIT\_HI}$	Current limit accuracy > 3 A	$I_{OUT} > 3\text{ A}$ , $V_{CSN/BUS} < 2.5\text{ V}$ ; $R_S = 10\text{ m}\Omega$	-20		20	%
$I_{LIMIT\_HI}$	Current limit accuracy > 3 A	$I_{OUT} > 3\text{ A}$ , $V_{CSN/BUS} \geq 2.5\text{ V}$ ; $R_S = 10\text{ m}\Omega$	-5		5	%
$I_{LIMIT\_MIN}$	Minimum programmable current limit		1			A
$I_{CL\_STEP}$	Current limit step size	$1\text{ A} \leq I_{OUT} \leq 5\text{ A}$ ; $R_S = 10\text{ m}\Omega$		50		mA
<b>FREQUENCY</b>						
$f_{SW(1)}$	Switching Frequency 1		285	300	315	kHz
$f_{SW(2)}$	Switching Frequency 2		380	400	420	kHz
$f_{SW(3)}$	Switching Frequency 3		428	450	473	kHz
<b>FREQUENCY DITHER</b>						
$FS_{SS}$	Positive frequency deviation during dither		8	10	12	%
	Negative frequency deviation during dither		-12	-10	-8	%
$FS_{SS\_MOD}$	Modulation frequency of dither	DITHER_FREQ = 0	9	10	11	kHz
$FS_{SS\_MOD}$	Modulation frequency of dither	DITHER_FREQ = 1	22.5	25	27.5	kHz
<b>OVERVOLTAGE PROTECTION</b>						
$V_{CSN/BUS\_OVP\_R}$	Fixed output overvoltage threshold at CSN/BUS pin		22.0	23	24	V
$V_{CSN/BUS\_OVP\_F}$	Falling		20.5	21.5	22.5	V
	Hysteresis			1.5		V
<b>POWER SWITCHES</b>						
$R_{DS(ON)}$	M1	$V_{IN} = 12\text{ V}$ ; $(V_{BOOT1} - V_{SW1}) = 4.5\text{ V}$ ; $I_{SW1} = -1\text{ A}$		4.5		m $\Omega$
$R_{DS(ON)}$	M2	$V_{IN} = 12\text{ V}$ ; $I_{SW1} = 1\text{ A}$		20		m $\Omega$
$R_{DS(ON)}$	M4	$V_{IN} = 12\text{ V}$ ; $I_{SW2} = 1\text{ A}$		6		m $\Omega$
$R_{DS(ON)}$	M3 + M5	$V_{IN} = V_{OUT} = 12\text{ V}$ ; $(V_{BOOT2} - V_{SW2}) = 4.5\text{ V}$ , $I_{SW2} = -1\text{ A}$		18		m $\Omega$
$V_{UV\_BOOT1\_R}$	BOOT1 to SW1 rising UVLO threshold		3.5	4	4.4	V
$V_{UV\_BOOT1\_F}$	BOOT1 to SW1 falling UVLO threshold		2.9	3.4	3.7	V
	BOOT1 to SW1 UVLO hysteresis			680		mV
$V_{OV\_BOOT1\_R}$	BOOT1 to SW1 rising OVP threshold		4.6	5.3	5.9	V
$V_{OV\_BOOT1\_F}$	BOOT1 to SW1 falling OVP threshold		4.3	5	5.6	V
	BOOT 1 OVP hysteresis		250	300	350	mV
$V_{UV\_BOOT2\_R}$	BOOT2 to SW2 rising UVLO threshold		3.5	4	4.4	V
$V_{UV\_BOOT2\_F}$	BOOT2 to SW2 falling UVLO threshold		2.9	3.4	3.7	V
	BOOT2 to SW2 UVLO hysteresis			680		mV

## 6.6 Buck-Boost Regulator (continued)

Typical values correspond to  $T_J = 25^\circ\text{C}$ . Minimum and maximum limits apply over the  $-40^\circ\text{C}$  to  $150^\circ\text{C}$  junction temperature range unless otherwise stated.  $V_{IN} = 13.5\text{ V}$ ,  $V_{EN/UVLO} = 2\text{ V}$  unless otherwise stated. <sup>(1)</sup>

PARAMETER		TEST CONDITION	MIN	TYP	MAX	UNIT
$V_{OV\_BOOT2\_R}$	BOOT2 to SW2 rising OVP threshold		4.6	5.3	5.9	V
$V_{OV\_BOOT2\_F}$	BOOT2 to SW2 falling OVP threshold		4.3	5	5.6	V
	BOOT2 OVP hysteresis		250	300	350	mV
<b>BUCK-BOOST CHARACTERISTICS</b>						
$t_{SS}$	Soft-start time			6		ms

(1) All minimum and maximum limits are specified by correlating the electrical characteristics to process and temperature variations and applying statistical process control.

## 6.7 CC Cable Detection Parameters

Typical values correspond to  $T_J = 25^\circ\text{C}$ . Minimum and maximum limits apply over the  $-40^\circ\text{C}$  to  $150^\circ\text{C}$  junction temperature range unless otherwise stated.  $V_{IN} = 13.5\text{ V}$ ,  $EN = 2\text{ V}$ , unless otherwise stated.

PARAMETER		TEST CONDITIONS	MIN	TYP	MAX	UNIT
<b>Type-C Source (Rp pull-up)</b>						
$V_{OC\_3.3}$	Unattached Px_CCy open circuit voltage while Rp enabled, no load	$R_{CC} = 47\text{ k}\Omega$	1.85			V
$V_{OC\_5}$	Attached Px_CCy open circuit voltage while Rp enabled, no load	$R_{CC} = 47\text{ k}\Omega$	2.95			V
$I_{Rev}$	Unattached reverse current on Px_CCy	$V_{CCy} = 5.5\text{ V}$ , $V_{CCx} = 0\text{ V}$ , measure current into CCy			10	$\mu\text{A}$
$I_{RpStd}$	current source - Standard	$0 < V_{CCy} < 1.0\text{ V}$ , measure $I_{CCy}$	64	80	96	$\mu\text{A}$
$I_{Rp1.5}$	current source - 1.5A	$0 < V_{CCy} < 1.5\text{ V}$ , measure $I_{CCy}$	166	180	194	$\mu\text{A}$
$I_{Rp3.0}$	current source - 3.0A	$0 < V_{CCy} < 2.45\text{ V}$ , measure $I_{CCy}$	304	330	356	$\mu\text{A}$
<b>Type-C Sink (Rd pull-down)</b>						
$R_{SNK}$	Rd pulldown resistance	$0\text{ V} \leq V_{Px\_CCy} \leq 2.1\text{ V}$ , measure resistance on Px_CCy	4.6		5.6	$\text{k}\Omega$
$R_{VCONN\_DIS}$	VCONN discharge resistance	$0\text{ V} \leq V_{Px\_CCy} \leq 5.5\text{ V}$ , measure resistance on Px_CCy	4.0		6.6	$\text{k}\Omega$
<b>Common (Source and Sink)</b>						
$t_{CC}$	deglitch time for comparators on Px_CCy, this applies for $V_{SRC1}$ , $V_{SRC2}$ , $V_{SRC3}$ , $V_{SNK1}$ , $V_{SNK2}$ , $V_{SNK3}$ , and $V_{SNK4}$ .			2.56		ms

## 6.8 CC VCONN Parameters

Typical values correspond to  $T_J = 25^\circ\text{C}$ . Minimum and maximum limits apply over the  $-40^\circ\text{C}$  to  $150^\circ\text{C}$  junction temperature range unless otherwise stated.  $V_{IN} = 13.5\text{ V}$ ,  $EN = 2\text{ V}$  unless otherwise stated.

PARAMETER		TEST CONDITIONS	MIN	TYP	MAX	UNIT
$R_{PP\_CABLE}$	Rdson of the VCONN path	$V_{LDO\_5V} = 5\text{ V}$ , $I_L = 200\text{ mA}$ , measure resistance from LDO_5V to Px_CCy			1.2	$\Omega$
$I_{LIMVC}$	short circuit current limit	setting 0, $V_{LDO\_5V} = 5\text{ V}$ , $R_L = 10\text{ m}\Omega$ , measure $I_{Px\_CCy}$	30	50	70	mA
		setting 1, $V_{LDO\_5V} = 5\text{ V}$ , $R_L = 10\text{ m}\Omega$ , measure $I_{Px\_CCy}$	235	275	315	
$I_{CCyLKG}$	Leakage current into Px_Cy pins	VCONN disabled, $T_J \leq 125^\circ\text{C}$ , $V_{Px\_CCy} = 5.5\text{ V}$ , measure $I_{Px\_CCy}$	-1	0	10	$\mu\text{A}$

## 6.8 CC VCONN Parameters (continued)

Typical values correspond to  $T_J = 25^\circ\text{C}$ . Minimum and maximum limits apply over the  $-40^\circ\text{C}$  to  $150^\circ\text{C}$  junction temperature range unless otherwise stated.  $V_{IN} = 13.5\text{ V}$ ,  $EN = 2\text{ V}$  unless otherwise stated.

PARAMETER		TEST CONDITIONS	MIN	TYP	MAX	UNIT
$V_{VC\_OVP}$	Over-voltage protection threshold for Px_CCy	$V_{LDO\_5V}$ rising	5.6	5.9	6.2	V
$V_{VC\_RCP}$	Reverse current protection threshold for Px_CCy, sourcing VCONN through CCx	$V_{LDO\_5V} = 5\text{ V}$ , $V_{CCx}$ rising, setting 1.	230	310	390	mV
$V_{VC\_RCP}$	Reverse current protection threshold for Px_CCy, sourcing VCONN through CCx	$V_{LDO\_5V} = 5\text{ V}$ , $V_{CCx}$ rising, setting 2.	60	155	250	mV
$t_{PP\_CABLE\_FSD}$	Time to disable Px_Cy VCONN after $V_{LDO\_5V} > V_{VC\_OVP}$ or $V_{CCx} - V_{LDO\_5V} > V_{VC\_RCP}$	$C_L = 0$		1.5		$\mu\text{s}$
$t_{PP\_CABLE\_off}$	from disable signal to Px_CCy at 10% of final value	$I_L = 200\text{ mA}$ , $V_{LDO\_5V} = 5\text{ V}$ , $C_L = 0$	100	225	300	$\mu\text{s}$
$t_{IOS\_PP\_CABLE}$	response time to short circuit	External $V_{LDO\_5V} = 5\text{ V}$ , for short circuit $R_L = 10\text{ m}\Omega$ . Set VCONILIM = 1.			2	$\mu\text{s}$
$t_{IOS\_PP\_CABLE}$	response time to short circuit	Internal $V_{LDO\_5V} = 5\text{ V}$ , for short circuit $R_L = 10\text{ m}\Omega$ . Set VCONILIM = 0.			0.3	$\mu\text{s}$

## 6.9 CC PHY Parameters

Typical values correspond to  $T_J = 25^\circ\text{C}$ . Minimum and maximum limits apply over the  $-40^\circ\text{C}$  to  $150^\circ\text{C}$  junction temperature range unless otherwise stated.  $V_{IN} = 13.5\text{ V}$ ,  $EN = 2\text{ V}$  unless otherwise stated.

PARAMETER		TEST CONDITIONS	MIN	TYP	MAX	UNIT
<b>Transmitter</b>						
$V_{TXHI}$	Transmit high voltage on Px_CCy	Standard External load	1.05	1.125	1.2	V
$V_{TXLO}$	Transmit low voltage on Px_CCy	Standard External load	-75		75	mV
$Z_{DRIVER}$	Transmit output impedance while driving the CC line using Px_CCy	measured at 750 kHz	33		75	$\Omega$
$t_{Rise}$	Rise time. 10 % to 90 % amplitude points on Px_CCy, minimum is under an unloaded condition. Maximum set by TX mask	$C_{Px\_CCy} = 520\text{ pF}$	300			ns
$t_{Fall}$	Fall time. 90 % to 10 % amplitude points on Px_CCy, minimum is under an unloaded condition. Maximum set by TX mask	$C_{Px\_CCy} = 520\text{ pF}$	300			ns
$V_{PHY\_OVP}$	OVP detection threshold for USB PD PHY.	Initially $V_{CC1} \leq 5.5\text{ V}$ and $V_{CC2} \leq 5.5\text{ V}$ , then $V_{CCx}$ rises.	5.5		8.5	V
<b>Receiver</b>						

## 6.9 CC PHY Parameters (continued)

Typical values correspond to  $T_J = 25^\circ\text{C}$ . Minimum and maximum limits apply over the  $-40^\circ\text{C}$  to  $150^\circ\text{C}$  junction temperature range unless otherwise stated.  $V_{IN} = 13.5\text{ V}$ ,  $EN = 2\text{ V}$  unless otherwise stated.

PARAMETER		TEST CONDITIONS	MIN	TYP	MAX	UNIT
$Z_{\text{BMCRX}}$ <sup>(2)</sup>	Receiver input impedance on Px_CCy	Does not include pull-up or pulldown resistance from cable detect. Transmitter is Hi-Z.	1			MΩ
$C_{\text{CC}}$	Receiver capacitance on Px_CCy <sup>(1)</sup>	Capacitance looking into the CC pin when in receiver mode			120	pF
$V_{\text{RX\_SNK\_R}}$	Rising threshold on Px_CCy for receiver comparator	sink mode (rising)	499	525	551	mV
$V_{\text{RX\_SRC\_R}}$	Rising threshold on Px_CCy for receiver comparator	source mode (rising)	784	825	866	mV
$V_{\text{RX\_SNK\_F}}$	Falling threshold on Px_CCy for receiver comparator	sink mode (falling)	230	250	270	mV
$V_{\text{RX\_SRC\_F}}$	Falling threshold on Px_CCy for receiver comparator	source mode (falling)	523	550	578	mV

- (1)  $C_{\text{CC}}$  includes only the internal capacitance on a Px\_CCy pin when the pin is configured to be receiving BMC data. External capacitance is needed to meet the required minimum capacitance per the USB-PD Specifications (cReceiver). Therefore, TI recommends adding  $C_{\text{Px\_CCy}}$  externally.
- (2) Specified by design; not production tested.

## 6.10 Thermal Shutdown Characteristics

over operating free-air temperature range (unless otherwise noted)

PARAMETER		TEST CONDITIONS	MIN	TYP	MAX	UNIT
$T_{\text{SD\_BB}}$	Temperature shutdown threshold	Temperature rising	160	167	175	$^\circ\text{C}$
$T_{\text{SD\_HYS}}$	Temperature shutdown hysteresis	hysteresis		18		$^\circ\text{C}$
$T_{\text{SD\_PA\_VCONN}}$	Temperature shutdown threshold	Temperature rising	152	166	179	$^\circ\text{C}$
$T_{\text{SD\_HYS}}$	Temperature shutdown hysteresis	hysteresis		20		$^\circ\text{C}$
$T_{\text{SD\_PA\_VBUS\_DISCH}}$	Temperature shutdown threshold	Temperature rising	155	166	177	$^\circ\text{C}$
$T_{\text{SD\_HYS}}$	Temperature shutdown hysteresis	hysteresis		20		$^\circ\text{C}$
$T_{\text{SD\_LDO5V}}$	Temperature shutdown threshold	Temperature rising	165	177	188	$^\circ\text{C}$
$T_{\text{SD\_HYS}}$	Temperature shutdown hysteresis	hysteresis		15		$^\circ\text{C}$

## 6.11 Oscillator Characteristics

Typical values correspond to  $T_J = 25^\circ\text{C}$ . Minimum and maximum limits apply over the  $-40^\circ\text{C}$  to  $150^\circ\text{C}$  junction temperature range unless otherwise stated.  $V_{IN} = 13.5\text{ V}$ ,  $EN = 2\text{ V}$ , unless otherwise stated.

PARAMETER		TEST CONDITIONS	MIN	TYP	MAX	UNIT
$F_{\text{OSC}(100\text{K})}$	100KHz oscillator	Trimmed.	89	103	111	kHz
$F_{\text{OSC}(24\text{M})}$	24MHz oscillator	Trimmed. $0^\circ\text{C} \leq T_A \leq 70^\circ\text{C}$	23.64	24.2	24.36	MHz
$F_{\text{OSC}(24\text{M})}$	24MHz oscillator	Trimmed. $-40^\circ\text{C} \leq T_A \leq 150^\circ\text{C}$	23.3	24.2	24.5	MHz

## 6.12 ADC Characteristics

Typical values correspond to  $T_J = 25^\circ\text{C}$ . Minimum and maximum limits apply over the  $-40^\circ\text{C}$  to  $150^\circ\text{C}$  junction temperature range unless otherwise stated.  $V_{IN} = 13.5\text{ V}$ ,  $EN = 2\text{ V}$ , unless otherwise stated.

PARAMETER		TEST CONDITIONS	MIN	TYP	MAX	UNIT
LSB	least significant bit	3.6V max scaling, voltage divider of 3		14		mV
LSB	least significant bit	25.2V max scaling, voltage divider of 21		98		mV
LSB	least significant bit	$(V_{CSP} - V_{CSN/BUS}) = 10\text{ mV}$ , 30 mV		27		mA
$E_G$	Gain error	$0\text{ A} \leq I_{TVSP} \leq 0.9\text{ mA}$	-2.7		2.7	%
$E_G$	Gain error	$0.05\text{ V} \leq V_{GPIOx} \leq 3.6\text{ V}$ , $V_{GPIOx} \leq V_{LDO\_3V3}$	-2.7		2.7	%
$E_G$	Gain error	$2.7\text{ V} \leq V_{LDO\_3V3} \leq 3.6\text{ V}$	-2.4		2.4	%
$E_G$	Gain error	$0.6\text{ V} \leq V_{P\_VBUS} \leq 22\text{ V}$	-2.4		2.4	%
$E_G$	Gain error, current sense	$(V_{CSP} - V_{CSN/BUS}) = 10\text{ mV}$ , 30 mV	-2.4		2.4	%
$E_G$	Gain error	$V_{IN}$	-2.4		2.4	%
$E_G$	Gain error	$4.3\text{ V} \leq V_{LDO\_5V} \leq 5.5\text{ V}$	-2.4		2.4	%
$V_{OS(E)}$	Offset error <sup>(1)</sup>	$0\text{ A} \leq I_{TVSP} \leq 0.9\text{ mA}$	-4.1		15	mV
$V_{OS(E)}$	Offset error <sup>(1)</sup>	$0.05\text{ V} \leq V_{GPIOx} \leq 3.6\text{ V}$ , $V_{GPIOx} \leq V_{LDO\_3V3}$	-4.1		4.1	mV
$V_{OS(E)}$	Offset error <sup>(1)</sup>	$2.7\text{ V} \leq V_{LDO\_3V3} \leq 3.6\text{ V}$	-4.1		4.1	mV
$V_{OS(E)}$	Offset error <sup>(1)</sup>	$0.6\text{ V} \leq V_{P\_VBUS} \leq 22\text{ V}$	-4.1		4.1	mV
$V_{OS(E)}$	Offset error <sup>(1)</sup>	$(V_{CSP} - V_{CSN/BUS}) = 10\text{ mV}$ , 30 mV	-4.5		4.5	mA
$V_{OS(E)}$	Offset error <sup>(1)</sup>	$V_{IN}$	-4.1		4.1	mV
$V_{OS(E)}$	Offset error <sup>(1)</sup>	$4.3\text{ V} \leq V_{LDO\_5V} \leq 5.5\text{ V}$	-4.1		4.1	mV

(1) The offset error is specified after the voltage divider.

## 6.13 TVSP Parameters

$V_{IN} = 13.5\text{ V}$ ,  $EN = 2\text{ V}$ , over operating free-air temperature range (unless otherwise noted)

PARAMETER		TEST CONDITIONS	MIN	TYP	MAX	UNIT
<b>TVSP</b>						
$V_{TVSP\_PU}$	Pull up voltage for configuration <sup>(1)</sup>	$0 < I_{TVSP} < 1\text{ mA}$	5.3	5.5	5.7	V
Decode 0	Device configuration decode	$R_{TVSP} = \text{Open}$			1	$\mu\text{A}$
Decode 1	Device configuration decode	$R_{TVSP} = 93.1\text{ k}\Omega$	56.9		61.2	$\mu\text{A}$
Decode 2	Device configuration decode	$R_{TVSP} = 47.5\text{ k}\Omega$	111.6		120	$\mu\text{A}$
Decode 3	Device configuration decode	$R_{TVSP} = 29.4\text{ k}\Omega$ - TPS257xxC-Q1, $R_{TVSP} = 26.7\text{ k}\Omega$ - TPS257xxD-Q1	180.3		193.9	$\mu\text{A}$
Decode 4	Device configuration decode	$R_{TVSP} = 20.0\text{ k}\Omega$ - TPS257xxC-Q1, $R_{TVSP} = 18.2\text{ k}\Omega$ - TPS257xxD-Q1	265		285	$\mu\text{A}$
Decode 5	Device configuration decode	$R_{TVSP} = 14.7\text{ k}\Omega$ - TPS257xxC-Q1, $R_{TVSP} = 13.0\text{ k}\Omega$ - TPS257xxD-Q1	360.5		387.8	$\mu\text{A}$
Decode 6	Device configuration decode	$R_{TVSP} = 11.0\text{ k}\Omega$ - TPS257xxC-Q1, $R_{TVSP} = 9.53\text{ k}\Omega$ - TPS257xxD-Q1	481.8		518.2	$\mu\text{A}$

### 6.13 TVSP Parameters (continued)

V<sub>IN</sub> = 13.5V, EN = 2V. over operating free-air temperature range (unless otherwise noted)

PARAMETER		TEST CONDITIONS	MIN	TYP	MAX	UNIT
Decode 7	Device configuration decode	R <sub>TVSP</sub> = 8.45 kΩ - TPS257xxC-Q1, R <sub>TVSP</sub> = 7.5 kΩ - TPS257xxD-Q1	627.2		674.6	μA
Decode 8	Device configuration decode	R <sub>TVSP</sub> = 6.65 kΩ - TPS257xxC-Q1, R <sub>TVSP</sub> = 5.6 kΩ - TPS257xxCA-Q1 and TPS257xxD-Q1	797		857.1	μA
I <sub>TVSP(ILIMIT)</sub>	Current limit when TVSP is sourcing.	C <sub>TVSP</sub> = open; R <sub>TVSP</sub> = open. All P <sub>X_Dy</sub> = 0 V and P <sub>X_CCy</sub> = 0 V. V <sub>TVSP</sub> = 0 V. Measure current flowing out of TVSP.	1.1	1.44	1.83	mA

(1) For proper device configuration, V<sub>IN</sub> must be ≥ 7.6 V at time of configuration read.

### 6.14 Input/Output (I/O) Characteristics

Typical values correspond to T<sub>J</sub> = 25°C. Minimum and maximum limits apply over the –40°C to 150°C junction temperature range unless otherwise stated. V<sub>IN</sub> = 13.5 V, EN = 2 V, unless otherwise stated.

PARAMETER		TEST CONDITIONS	MIN	TYP	MAX	UNIT
<b>GPIO0-9 (Inputs) <sup>(1)</sup></b>						
V <sub>IH</sub>	GPIOx high-level input voltage		1.3			V
V <sub>IL</sub>	GPIOx low-level input voltage				0.54	V
	GPIOx input hysteresis voltage		0.09			V
I <sub>I(LEAKAGE)</sub>	GPIOx leakage current	V <sub>GPIOx</sub> = 5.5 V	–8		8	μA
R <sub>PU</sub>	GPIOx internal pull-up	pull-up enabled	50	100	150	kΩ
R <sub>PD</sub>	GPIOx internal pull-down	pull-down enabled	50	100	150	kΩ
t <sub>DG</sub>	GPIOx input deglitch			20		ns
<b>GPIO 2, 3, 5, 6 (Outputs)</b>						
V <sub>OH</sub>	GPIOx output high voltage	I <sub>GPIOx</sub> = –5mA	2.9			V
V <sub>OL</sub>	GPIOx output low voltage	I <sub>GPIOx</sub> = 5mA			0.4	V
<b>GPIO 0, 1, 4, 7, 8, 9 (Outputs) <sup>(2)</sup></b>						
V <sub>OH</sub>	GPIOx output high voltage	I <sub>GPIOx</sub> = –2mA	2.9			V
V <sub>OL</sub>	GPIOx output low voltage	I <sub>GPIOx</sub> = 2mA			0.4	V
<b>SYNC OUT</b>						
φ shift_00	GPIOx when configured as phase shifted DC/DC fsw clock output	Phase difference between fsw and GPIO6 when configured as SYNC(O).		0		degrees
φ shift_90	GPIOx when configured as phase shifted DC/DC fsw clock output	Phase difference between fsw and GPIO6 when configured as SYNC(O).		90		degrees
φ shift_120	GPIOx when configured as phase shifted DC/DC fsw clock output	Phase difference between fsw and GPIO6 when configured as SYNC(O).		120		degrees
φ shift_180	GPIOx when configured as phase shifted DC/DC fsw clock output	Phase difference between fsw and GPIO6 when configured as SYNC(O).		180		degrees
<b>SYNC IN</b>						
f <sub>SYNC(300kHz)</sub>	Valid external clock frequency (f <sub>SW_internal</sub> = 300kHz)		250		353	kHz
f <sub>SYNC(400kHz)</sub>	Valid external clock frequency (f <sub>SW_internal</sub> = 400kHz)		334		470	kHz

## 6.14 Input/Output (I/O) Characteristics (continued)

Typical values correspond to  $T_J = 25^\circ\text{C}$ . Minimum and maximum limits apply over the  $-40^\circ\text{C}$  to  $150^\circ\text{C}$  junction temperature range unless otherwise stated.  $V_{IN} = 13.5\text{ V}$ ,  $EN = 2\text{ V}$ , unless otherwise stated.

PARAMETER		TEST CONDITIONS	MIN	TYP	MAX	UNIT
$f_{\text{SYNC}(450\text{kHz})}$	Valid external clock frequency ( $f_{\text{SW\_internal}} = 450\text{kHz}$ )		376		530	kHz
<b>LSGD</b>						
$I_{\text{LSGD\_ON}}$	NFET driver sourcing current	$0\text{ V} \leq V_{\text{CSN/BUS}} \leq 21\text{ V}$ ; $0\text{ V} \leq (V_{\text{LSGD}} - V_{\text{CSN/BUS}}) \leq 4\text{ V}$	10	13	16	$\mu\text{A}$
$V_{\text{LSGD\_ON}}$	Sourcing voltage while enabled ( $V_{\text{LSGD}} - V_{\text{CSN/BUS}}$ )	$0\text{ V} \leq V_{\text{CSN/BUS}} \leq 21\text{ V}$ ; $I_{\text{LSGD}} \leq 4\text{ }\mu\text{A}$ . Measure voltage between LSGD and CSN/BUS.	6		8	V
$R_{\text{LSGD\_OFF}}$	Sinking resistance when disabled	$V_{\text{LSGD}} = V_{\text{CSN/BUS}} = 5\text{ V}$		160	300	k $\Omega$

- (1) GPIO9 is normally configured as I2C\_IRQ1m (controller): input pin. I2C specification requires use of external pullup resistor. Input thresholds ( $V_{IH}$ ;  $V_{IL}$ ) leakage current ( $I_{I(\text{LEAKAGE})}$ ) and deglitch timing ( $t_{DG}$ ) specifications apply when used as I2C\_IRQ1m. Internal pullup and pulldown resistors are not used during this mode of operation.
- (2) GPIO9 or GPIO1 may be configured as I2C\_IRQ2s (target): open-drain output pin. I2C specification requires use of external pullup resistor. Output threshold ( $V_{OL}$ ) applies. Internal pullup and pulldown resistors are not used during this mode of operation.

## 6.15 BC1.2 Characteristics

Typical values correspond to  $T_J = 25^\circ\text{C}$ . Minimum and maximum limits apply over the  $-40^\circ\text{C}$  to  $150^\circ\text{C}$  junction temperature range unless otherwise stated.  $V_{IN} = 13.5\text{ V}$ ,  $EN = 2\text{ V}$ , unless otherwise stated.

PARAMETER		TEST CONDITIONS	MIN	TYP	MAX	UNIT
<b>BC1.2 RESISTANCES</b>						
$R_{\text{DCP\_DAT}}$	Dedicated Charging Port Resistance between $P_{X\_DP}$ and $P_{X\_DM}$	$V_{P_{X\_DP}} = 0.6\text{ V}$ , $V_{P_{X\_DM}} = 0\text{ V}$ , measure DP to DM shorted resistance			200	$\Omega$
$R_{\text{DM\_DWN\_15k}}$	$P_{X\_DM}$ line pulldown resistance	$V_{P_{X\_DM}} = 3.6\text{ V}$	12	15	18	k $\Omega$
$R_{\text{DM\_DWN\_20k}}$	$P_{X\_DM}$ line pulldown resistance	$V_{P_{X\_DM}} = 3.6\text{ V}$	14.25	19.53	24.8	k $\Omega$
<b>DIVIDER MODES</b>						
$V_{2.7V}$	Output Voltage on DPy pin	No load on DPy pin	2.57	2.7	2.83	V
$V_{2.7V}$	Output Voltage on DMy pin	No load on DMy pin	2.57	2.7	2.83	V
$R_{2.7V}$	Output Impedance on DPy	$5\text{ }\mu\text{A}$ pulled from DPy pin	24	30	36	k $\Omega$
$R_{2.7V}$	Output Impedance on DMy	$5\text{ }\mu\text{A}$ pulled from DMy pin	24	30	36	k $\Omega$
$V_{1.2V}$	Output Voltage on DMy	No load on DMy	1.12	1.2	1.28	V
$R_{1.2V}$	Output Impedance on DMy	$5\text{ }\mu\text{A}$ pulled from DMy	80	102	130	k $\Omega$
<b>HVDCP THRESHOLD VOLTAGES</b>						
$V_{\text{DAT\_REF}}$	Data detection voltage on DP or DM pin		0.25	0.325	0.4	V
$V_{\text{SEL\_REF}}$	Output selection voltage DP or DM pin		1.8	2	2.2	V
<b>DP AND DM OVERVOLTAGE PROTECTION</b>						
$V_{\text{Dy\_OVP}}$	OVP detection threshold for USB $P_{X\_DP}$ and $P_{X\_DM}$ pins	Initially $V_{P_{XDy}} \leq 3.6\text{ V}$ , then $V_{P_{XDy}}$ rises.	5.5		8.5	V

## 6.16 I2C Requirements and Characteristics

Typical values correspond to  $T_J = 25^\circ\text{C}$ . Minimum and maximum limits apply over the  $-40^\circ\text{C}$  to  $150^\circ\text{C}$  junction temperature range unless otherwise stated.  $V_{IN} = 13.5\text{ V}$ ,  $EN = 2\text{ V}$ , unless otherwise stated.  $V_{DD} = \text{I2C pullup voltage (3.3 V or 1.8 V)}$

PARAMETER		TEST CONDITIONS	MIN	TYP	MAX	UNIT
<b>I2C_IRQ1s, I2C_IRQ2</b>						
<b>I2C_IRQ1m</b>						
<b>SDA and SCL Characteristics (Standard, Fast, Fast-mode Plus)</b>						
$V_{IL}$	Input low signal				0.54	V

## 6.16 I2C Requirements and Characteristics (continued)

Typical values correspond to  $T_J = 25^\circ\text{C}$ . Minimum and maximum limits apply over the  $-40^\circ\text{C}$  to  $150^\circ\text{C}$  junction temperature range unless otherwise stated.  $V_{IN} = 13.5\text{ V}$ ,  $EN = 2\text{ V}$ , unless otherwise stated.  $V_{DD} = \text{I2C pullup voltage (3.3 V or 1.8 V)}$

PARAMETER		TEST CONDITIONS	MIN	TYP	MAX	UNIT
$V_{IH}$	Input high signal		1.3			V
<b><math>V_{DD} = 3.3\text{ V}</math> INPUT LOGIC THRESHOLDS</b>						
$V_{IL}$	Input low signal				0.9	V
$V_{IH}$	Input high signal		2.31			V
$V_{HYS}$	Input hysteresis		0.165			V
$V_{OL}$	Output low voltage	$V_{DD} = 1.8\text{ V}$ , $I_{OL} = 2\text{ mA}$			0.36	
$V_{OL}$	Output low voltage	$V_{DD} = 3.3\text{ V}$ , $I_{OL} = 3\text{ mA}$			0.4	V
$I_{OL}$	Max output low current	$V_{OL} = 0.4\text{ V}$	12			mA
$I_{LEAK}$	Input leakage current	Voltage on pin = 3.3V	-5		5	$\mu\text{A}$
$C_i$	pin capacitance (internal)				10	pF
$C_b$	Capacitive load for each bus line (external). Applies in Standard-mode and Fast-mode.				400	pF
$C_b$	Capacitive load for each bus line (external). Applies in Fast-mode Plus.				550	pF
<b>COMMON TIMING</b>						
$t_{SP}$	I2C pulse width suppressed				50	ns
<b>SDA and SCL Characteristics (Standard Mode)</b>						
$f_{SCLS}$	Clock frequency (target)	$V_{DD} = 1.8\text{ V}$ or $3.3\text{ V}$			100	kHz
$t_{HD;STA}$	Start or repeated start condition hold time	$V_{DD} = 1.8\text{ V}$ or $3.3\text{ V}$	4			$\mu\text{s}$
$t_{LOW}$	SCL Clock low time	$V_{DD} = 1.8\text{ V}$ or $3.3\text{ V}$	4.7			$\mu\text{s}$
$t_{HIGH}$	SCL Clock high time	$V_{DD} = 1.8\text{ V}$ or $3.3\text{ V}$	4			$\mu\text{s}$
$t_{SU;STA}$	Start or repeated start condition setup time	$V_{DD} = 1.8\text{ V}$ or $3.3\text{ V}$	4.7			$\mu\text{s}$
$t_{HD;DAT}$	Serial data hold time <sup>(1)</sup>	$V_{DD} = 1.8\text{ V}$ or $3.3\text{ V}$	0 <sup>(2)</sup>		- <sup>(3)</sup>	ns
$t_{SU;DAT}$	Serial data setup time	$V_{DD} = 1.8\text{ V}$ or $3.3\text{ V}$	250			ns
$t_r$	Rise time of SCL and SDA signals	$V_{DD} = 1.8\text{ V}$ or $3.3\text{ V}$ ; $R_{PU} = 2.8\text{ k}\Omega$ ; $C_b = 400\text{ pF}$ ; measure $0.3 \times V_{DD}$ to $0.7 \times V_{DD}$			1000	ns
$t_{of}$	Output fall time from $V_{IH(MIN)}$ to $V_{IL(MAX)}$	$V_{DD} = 1.8\text{ V}$ or $3.3\text{ V}$ ; measure $0.3 \times V_{DD}$ to $0.7 \times V_{DD}$			250 <sup>(4)</sup>	ns
$t_f$	Fall time of SCL and SDA signals <sup>(2) (4) (5)</sup>	$V_{DD} = 1.8\text{ V}$ , $R_{PU} = 2.8\text{ k}\Omega$ ; $10\text{ pF} \leq C_b \leq 400\text{ pF}$			300	ns
$t_f$	Fall time of SCL and SDA signals <sup>(2) (4) (5)</sup>	$V_{DD} = 3.3\text{ V}$ , $R_{PU} = 2.8\text{ k}\Omega$ ; $10\text{ pF} \leq C_b \leq 400\text{ pF}$			300	ns
$t_{SU;STO}$	Stop condition setup time	$V_{DD} = 1.8\text{ V}$ or $3.3\text{ V}$	4			$\mu\text{s}$
$t_{BUF}$	Bus free time between stop and start	$V_{DD} = 1.8\text{ V}$ or $3.3\text{ V}$	4.7			$\mu\text{s}$
$t_{VD;DAT}$	Valid data time <sup>(6)</sup>	Transmitting Data; $V_{DD} = 1.8\text{ V}$ or $3.3\text{ V}$ , SCL low to SDA output valid			3.45 <sup>(3)</sup>	$\mu\text{s}$
$t_{VD;ACK}$	Valid data time of ACK condition	Transmitting Data; $V_{DD} = 1.8\text{ V}$ or $3.3\text{ V}$ , ACK signal from SCL low to SDA valid			3.45 <sup>(3)</sup>	$\mu\text{s}$
<b>SDA and SCL Characteristics (Fast Mode)</b>						
$f_{SCLS}$	Clock frequency (target)	$V_{DD} = 1.8\text{ V}$ or $3.3\text{ V}$			400	kHz

## 6.16 I2C Requirements and Characteristics (continued)

Typical values correspond to  $T_J = 25^\circ\text{C}$ . Minimum and maximum limits apply over the  $-40^\circ\text{C}$  to  $150^\circ\text{C}$  junction temperature range unless otherwise stated.  $V_{IN} = 13.5\text{ V}$ ,  $EN = 2\text{ V}$ , unless otherwise stated.  $V_{DD} = \text{I2C pullup voltage (3.3 V or 1.8 V)}$

PARAMETER		TEST CONDITIONS	MIN	TYP	MAX	UNIT
$t_{HD,STA}$	Start or repeated start condition hold time	$V_{DD} = 1.8\text{V or }3.3\text{V}$	0.6			$\mu\text{s}$
$t_{LOW}$	SCL Clock low time	$V_{DD} = 1.8\text{V or }3.3\text{V}$	1.3			$\mu\text{s}$
$t_{HIGH}$	SCL Clock high time	$V_{DD} = 1.8\text{V or }3.3\text{V}$	0.6			$\mu\text{s}$
$t_{SU,STA}$	Start or repeated start condition setup time	$V_{DD} = 1.8\text{V or }3.3\text{V}$	0.6			$\mu\text{s}$
$t_{HD,DAT}$	Serial data hold time <sup>(1)</sup>	$V_{DD} = 1.8\text{V or }3.3\text{V}$	0 <sup>(2)</sup>		- <sup>(3)</sup>	ns
$t_{SU,DAT}$	Serial data setup time	$V_{DD} = 1.8\text{V or }3.3\text{V}$	100 <sup>(7)</sup>			ns
$t_r$	Rise time of SCL and SDA signals	$V_{DD} = 1.8\text{V or }3.3\text{V}$ ; $R_{PU} = 850\ \Omega$ ; $C_b = 400\ \text{pF}$ ; measure $0.3 \times V_{DD}$ to $0.7 \times V_{DD}$	20		300	ns
$t_{of}$	Output fall time from $V_{IH(MIN)}$ to $V_{IL(MAX)}$	$V_{DD} = 1.8\text{V}$ ; measure $0.3 \times V_{DD}$ to $0.7 \times V_{DD}$	6.55		250 <sup>(4)</sup>	ns
$t_{of}$	Output fall time from $V_{IH(MIN)}$ to $V_{IL(MAX)}$	$V_{DD} = 3.3\text{V}$ ; measure $0.3 \times V_{DD}$ to $0.7 \times V_{DD}$	12		250 <sup>(4)</sup>	ns
$t_f$	Fall time of SCL and SDA signals <sup>(2) (4) (5)</sup>	$V_{DD} = 1.8\text{V}$ ; $R_{PU} = 850\ \Omega$ ; $10\ \text{pF} \leq C_b \leq 400\ \text{pF}$	6.55		300	ns
$t_f$	Fall time of SCL and SDA signals <sup>(2) (4) (5)</sup>	$V_{DD} = 3.3\text{V}$ ; $R_{PU} = 850\ \Omega$ ; $10\ \text{pF} \leq C_b \leq 400\ \text{pF}$	12		300	ns
$t_{SU,STO}$	Stop condition setup time	$V_{DD} = 1.8\text{V or }3.3\text{V}$	0.6			$\mu\text{s}$
$t_{BUF}$	Bus free time between stop and start	$V_{DD} = 1.8\text{V or }3.3\text{V}$	1.3			$\mu\text{s}$
$t_{VD,DAT}$	Valid data time <sup>(6)</sup>	Transmitting Data; $V_{DD} = 1.8\text{V or }3.3\text{V}$ , SCL low to SDA output valid			0.9 <sup>(3)</sup>	$\mu\text{s}$
$t_{VD,ACK}$	Valid data time of ACK condition	Transmitting Data; $V_{DD} = 1.8\text{V or }3.3\text{V}$ , ACK signal from SCL low to SDA (out) low			0.9 <sup>(3)</sup>	$\mu\text{s}$

- (1)  $t_{HD,DAT}$  = the data hold time that is measured from the falling edge of SCL, applies to data in transmission and the acknowledge.
- (2) A device must internally provide a hold time of at least 300 ns for the SDA signal (with respect to the  $V_{IH(MIN)}$  of the SCL signal) to bridge the undefined region of the falling edge of SCL.
- (3) The maximum  $t_{HD,DAT}$  can be 3.45  $\mu\text{s}$  and 0.9  $\mu\text{s}$  for Standard-mode and Fast-mode, but must be less than the maximum  $t_{VD,DAT}$  or  $t_{VD,ACK}$  by a transition time. This maximum must only be met if the device does not stretch the LOW period ( $t_{LOW}$ ) of the SCL signal. If the clock stretches the SCL, the data must be valid by the setup time before it releases the clock.
- (4) The maximum  $t_f$  for the SDA and SCL bus lines is stated in these tables as 300 ns and is longer than the specified maximum  $t_{of}$  for the output stages (250 ns). The maximum  $t_f$  allows series protection resistors ( $R_S$ ) to be connected between the SDA and SCL pins and the SDA and SCL bus lines without exceeding the maximum specified  $t_f$ .
- (5) In Fast-mode Plus, fall time is specified the same for both output stage and bus timing. If series resistors ( $R_S$ ) are used, the design must allow for inclusion when considering bus timing.
- (6)  $t_{VD,DAT}$  = time for data signal from SCL LOW to SDA output (HIGH or LOW, depending on which one is worse).
- (7) A Fast-mode I2C-bus device can be used in a Standard-mode I2C-bus system, but the requirement  $t_{SU,DAT}$  250 ns must then be met. This requirement is automatically met if the device does not stretch the LOW period of the SCL signal. If such a device does stretch the LOW period of the SCL signal, it must output the next data bit to the SDA line  $t_{r(max)} + t_{SU,DAT} = 1000 + 250 = 1250\ \text{ns}$  (according to the Standard-mode I2C-bus specification) before the SCL line is released. Also the acknowledge timing must meet this set-up time.

### 6.17 Typical Characteristics

At  $V_{IN} = 12\text{ V}$ ,  $f_{sw} = 400\text{ kHz}$ , unless otherwise stated.

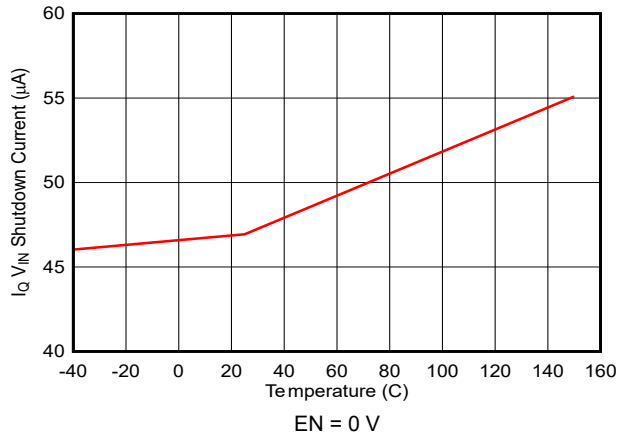


Figure 6-1.  $I_Q V_{IN}$  Shutdown Current vs Temperature

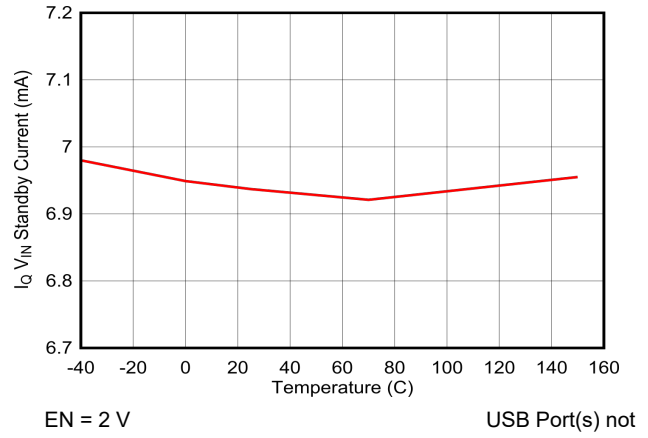


Figure 6-2.  $I_Q V_{IN}$  Standby Current vs Temperature

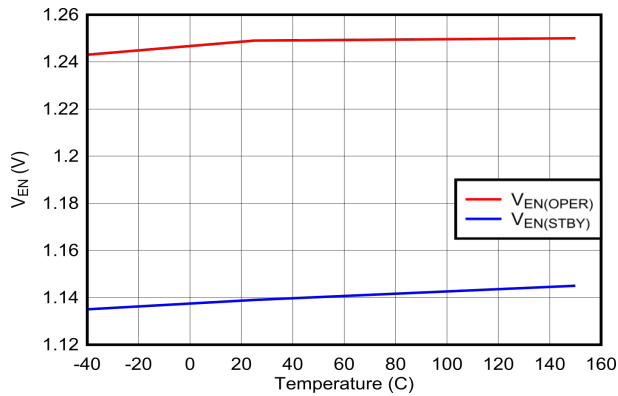


Figure 6-3. ENABLE/UVLO Thresholds vs Temperature

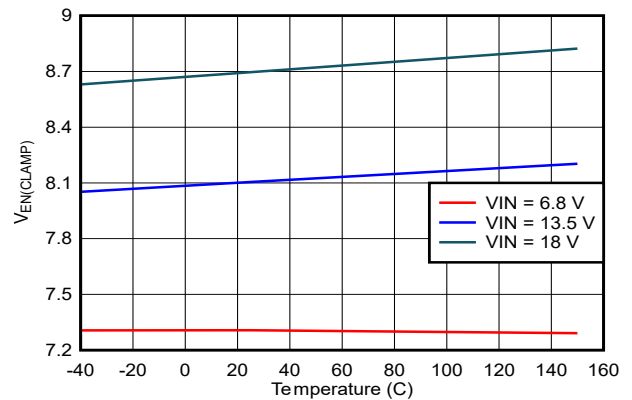


Figure 6-4. EN Clamp Voltage vs Temperature

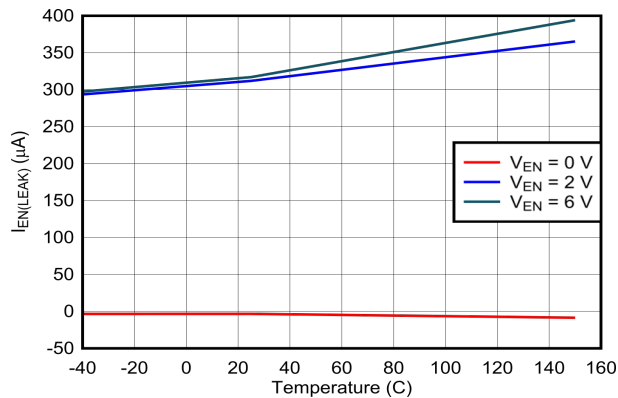


Figure 6-5. EN Leakage Current vs Temperature

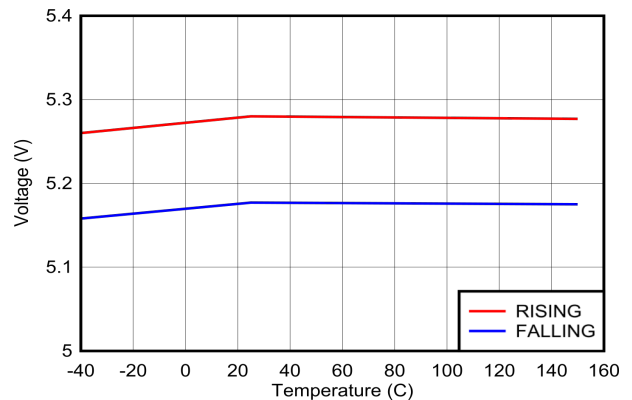


Figure 6-6.  $V_{IN(UVLO)}$  vs Temperature

### 6.17 Typical Characteristics (continued)

At  $V_{IN} = 12\text{ V}$ ,  $f_{sw} = 400\text{ kHz}$ , unless otherwise stated.

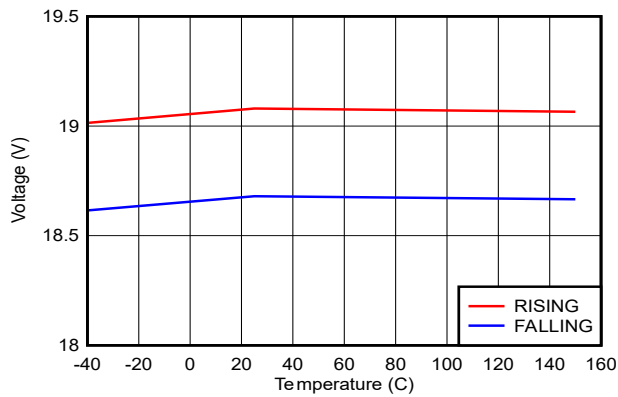


Figure 6-7.  $V_{IN(OVP)}$  vs Temperature

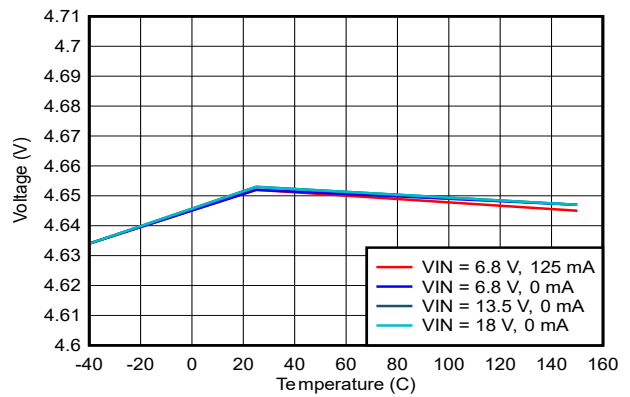


Figure 6-8. LDO\_5V vs  $V_{IN}$  and Temperature

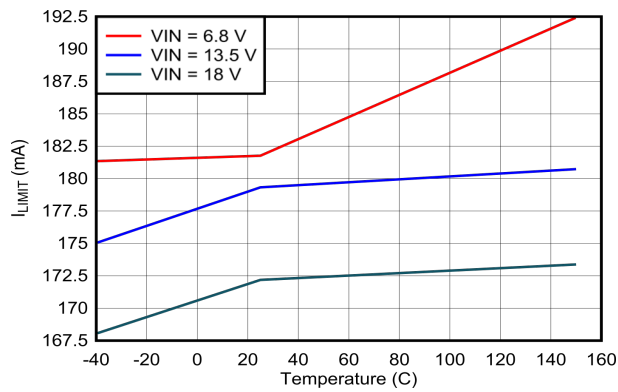


Figure 6-9. LDO\_5V Current Limit vs  $V_{IN}$  and Temperature

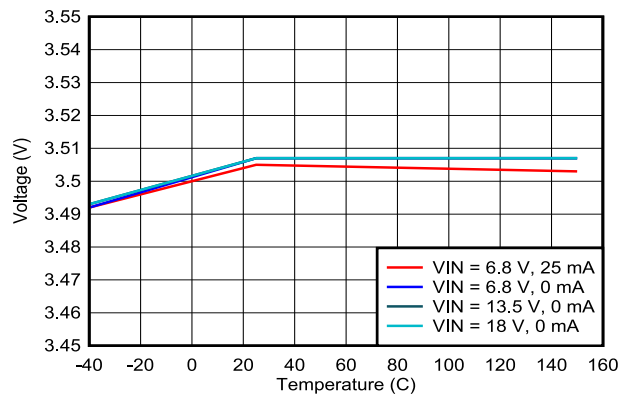


Figure 6-10. LDO\_3V3 vs  $V_{IN}$  and Temperature

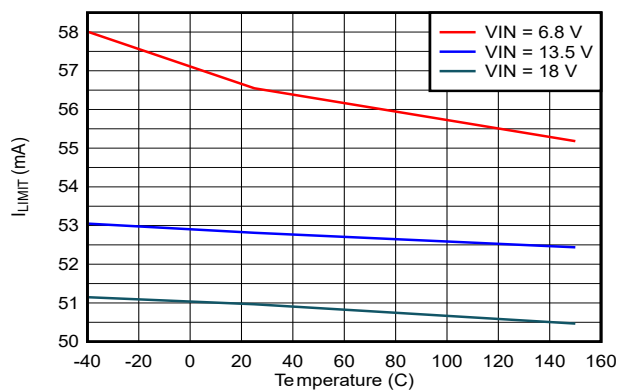


Figure 6-11. LDO\_3V3 Current Limit vs  $V_{IN}$  and Temperature

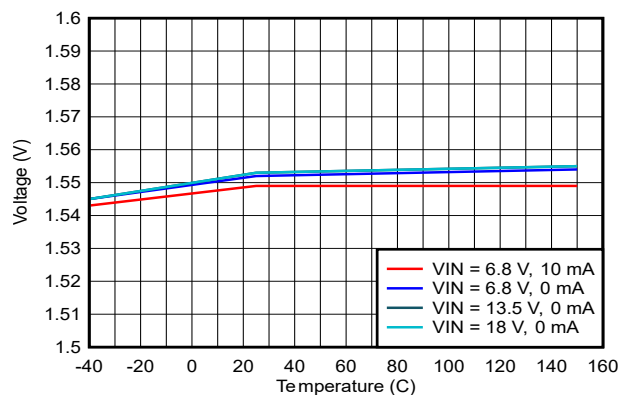


Figure 6-12. LDO\_1V5 vs  $V_{IN}$  and Temperature

### 6.17 Typical Characteristics (continued)

At  $V_{IN} = 12\text{ V}$ ,  $f_{sw} = 400\text{ kHz}$ , unless otherwise stated.

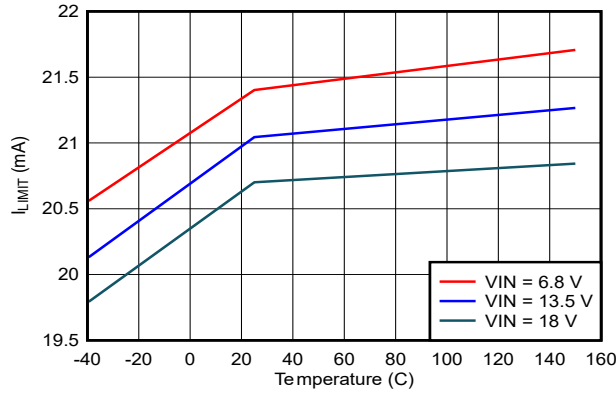


Figure 6-13. LDO\_1V5 Current Limit vs  $V_{IN}$  and Temperature

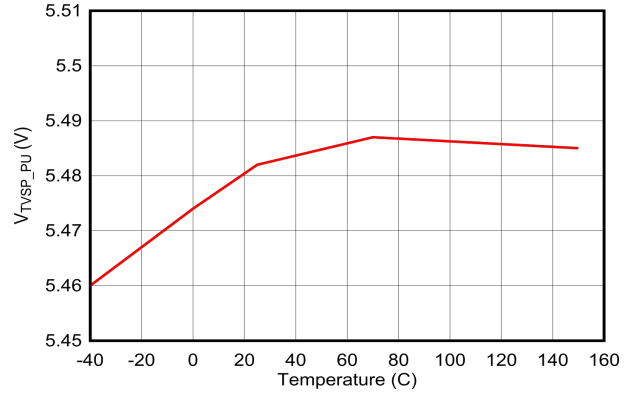


Figure 6-14.  $V_{TVSP\_PU}$  vs Temperature

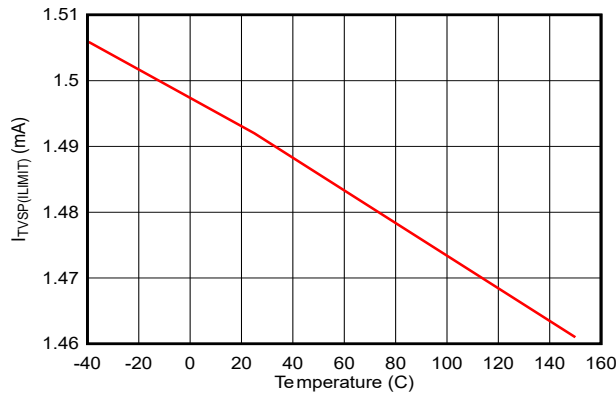


Figure 6-15.  $I_{TVSP(ILIMIT)}$  vs Temperature

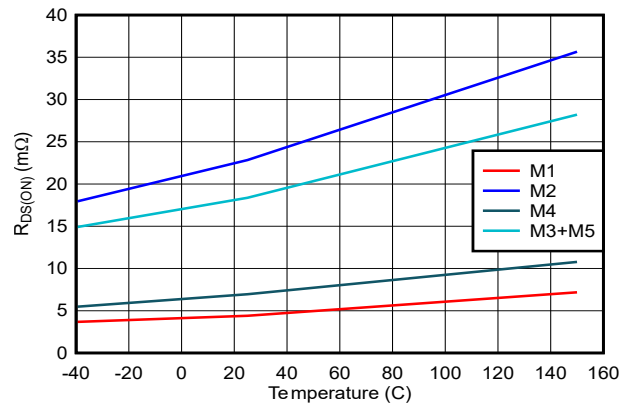


Figure 6-16. Buck-Boost Power FET  $R_{DS(ON)}$  vs Temperature

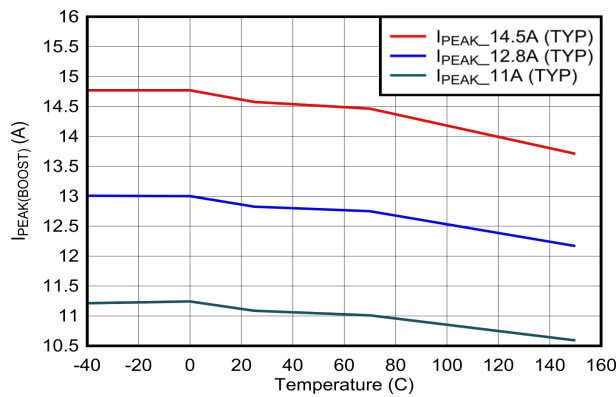


Figure 6-17. Boost Peak Current Limit vs Temperature (upper settings)

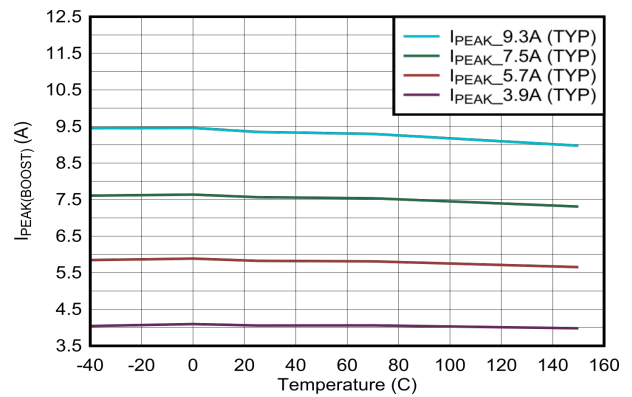


Figure 6-18. Boost Peak Current Limit vs Temperature (lower settings)

### 6.17 Typical Characteristics (continued)

At  $V_{IN} = 12\text{ V}$ ,  $f_{sw} = 400\text{ kHz}$ , unless otherwise stated.

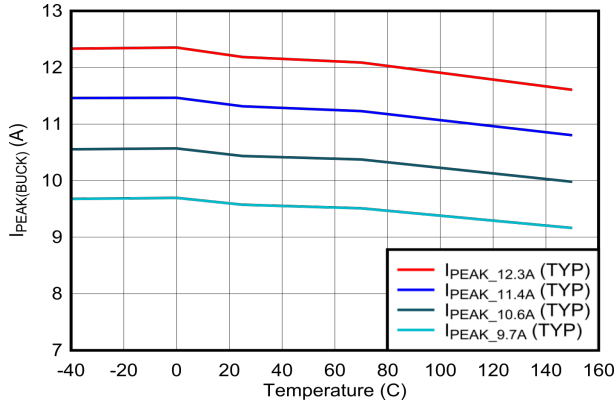


Figure 6-19. Buck Peak Current Limit vs Temperature (upper settings)

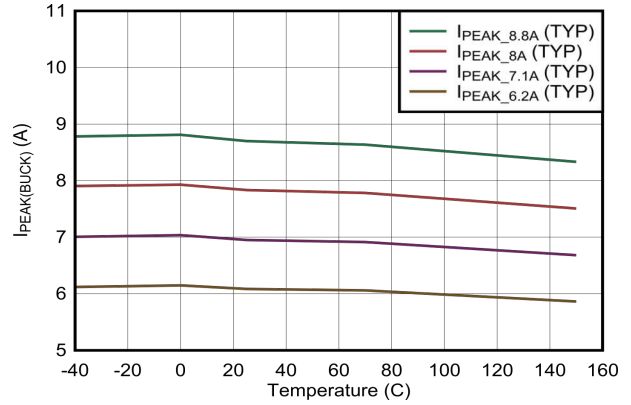


Figure 6-20. Buck Peak Current Limit vs Temperature (lower settings)

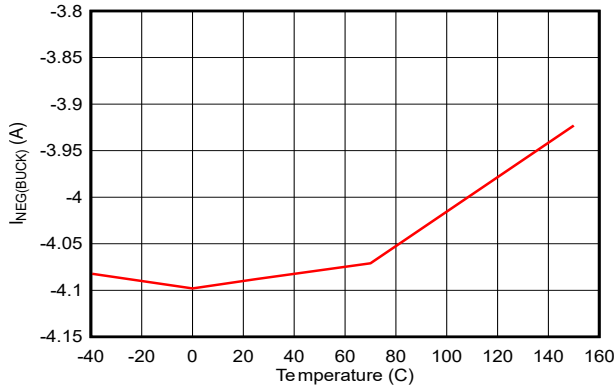


Figure 6-21. Buck Negative Current Limit vs Temperature

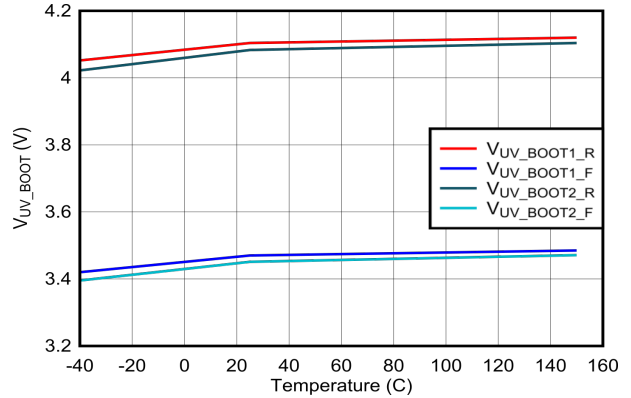


Figure 6-22. BOOTx UVLO vs Temperature

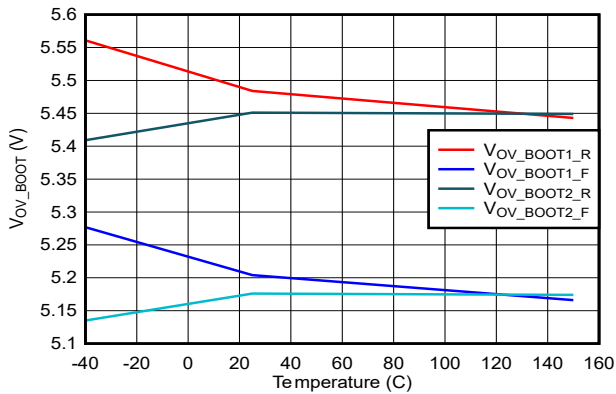


Figure 6-23. BOOTx OVP vs Temperature

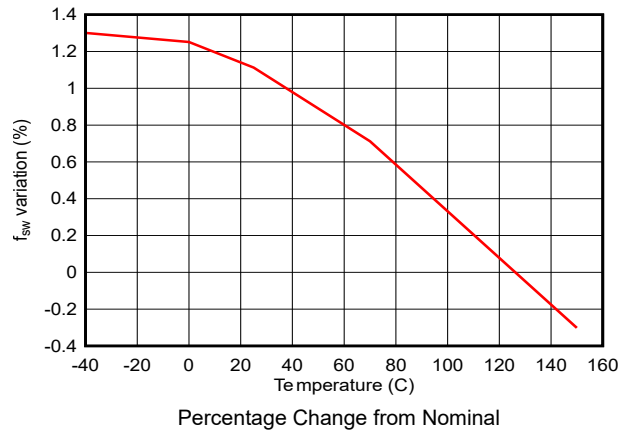


Figure 6-24. Buck-Boost Switching Frequency Variation vs Temperature

### 6.17 Typical Characteristics (continued)

At  $V_{IN} = 12\text{ V}$ ,  $f_{sw} = 400\text{ kHz}$ , unless otherwise stated.

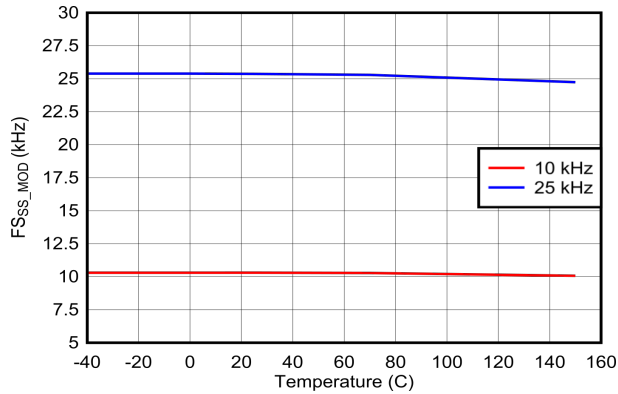
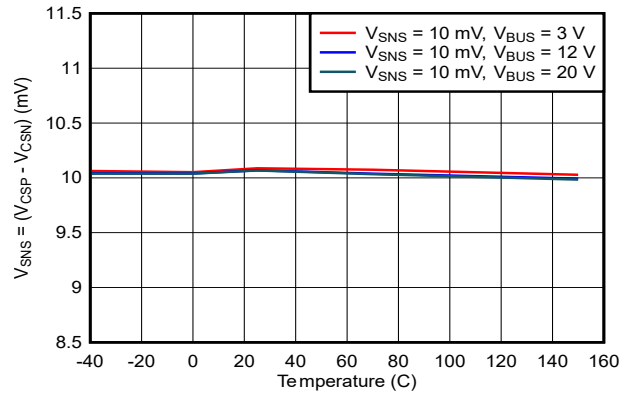
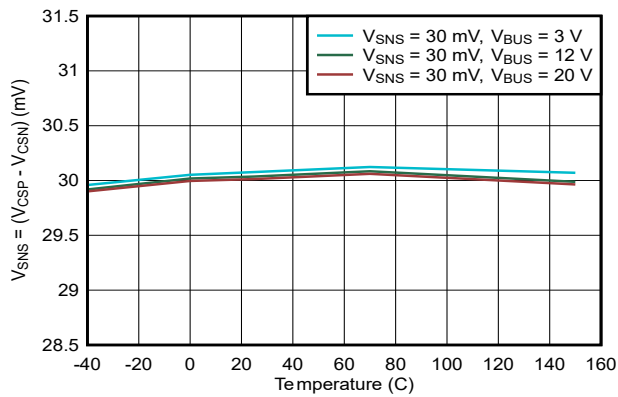


Figure 6-25.  $f_{sw}$  Dither Modulation Frequency vs Temperature



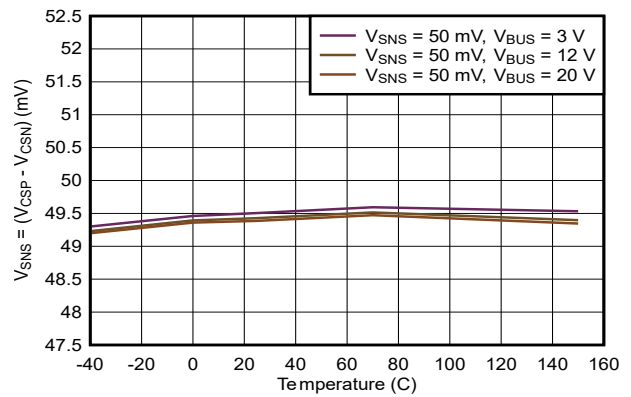
Target  $V_{SNS}$  for Current Limit = 10 mV  
Current Limiting Engaged

Figure 6-26. Current Loop Regulation Voltage vs  $V_{BUS}$  and Temperature



Target  $V_{SNS}$  for Current Limit = 30 mV  
Current Limiting Engaged

Figure 6-27. Current Loop Regulation Voltage vs  $V_{BUS}$  and Temperature



Target  $V_{SNS}$  for Current Limit = 50 mV  
Current Limiting Engaged

Figure 6-28. Current Loop Regulation Voltage vs  $V_{BUS}$  and Temperature

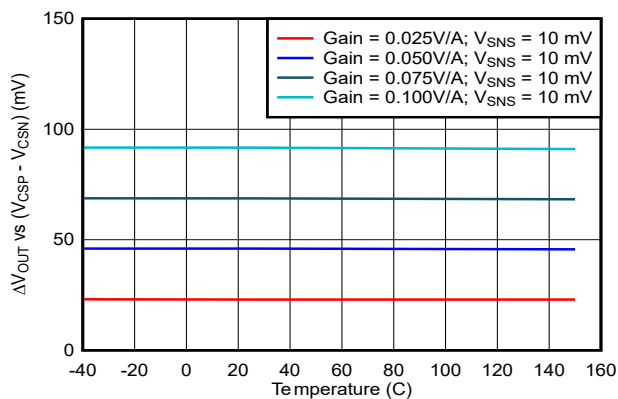


Figure 6-29. Cable Voltage Droop Compensation vs Temperature

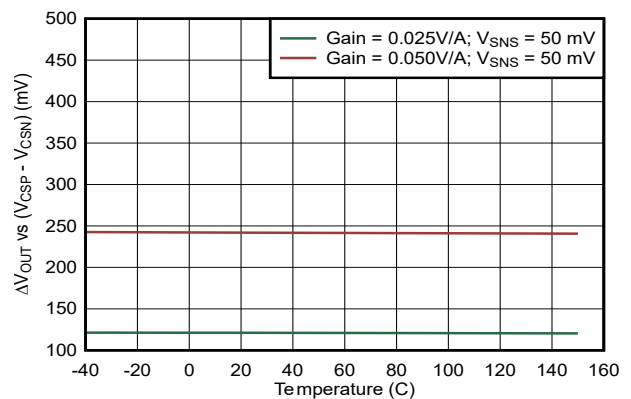


Figure 6-30. Cable Voltage Droop Compensation vs Temperature

### 6.17 Typical Characteristics (continued)

At  $V_{IN} = 12\text{ V}$ ,  $f_{sw} = 400\text{ kHz}$ , unless otherwise stated.

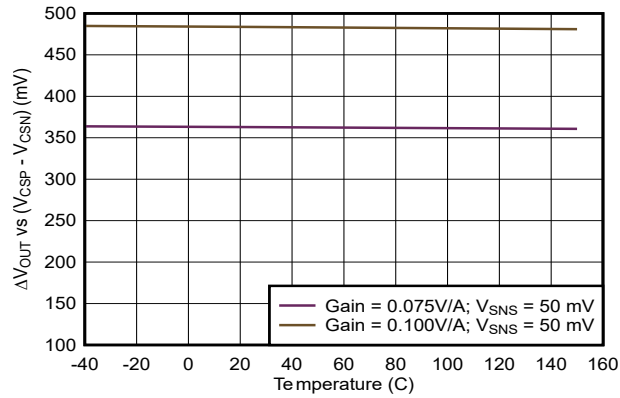
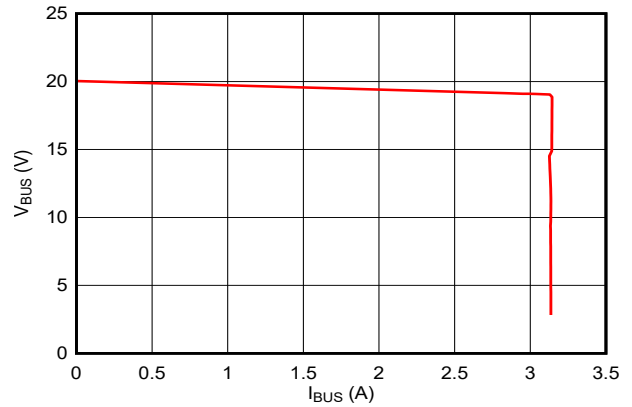


Figure 6-31. Cable Voltage Droop Compensation vs Temperature



$V_{IN} = 13.5\text{ V}$      $V_{BUS} = 20\text{ V (CV)}$      $I_{LIMIT} = 3.15\text{ A (CC)}$

Figure 6-32. Constant Voltage to Constant Current Transition

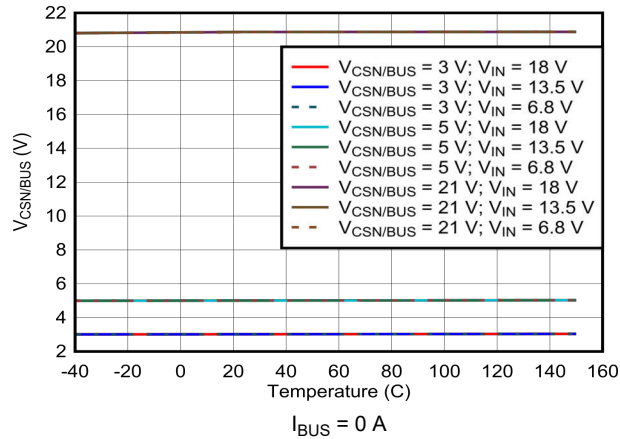


Figure 6-33. Buck-boost Output Voltage Regulation vs Temperature

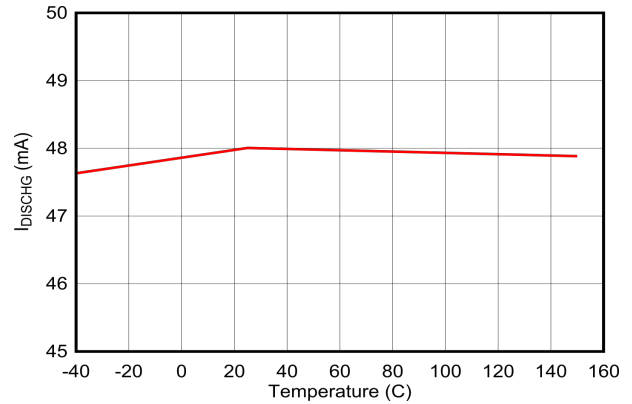


Figure 6-34.  $V_{BUS}$  Discharge Current vs Temperature

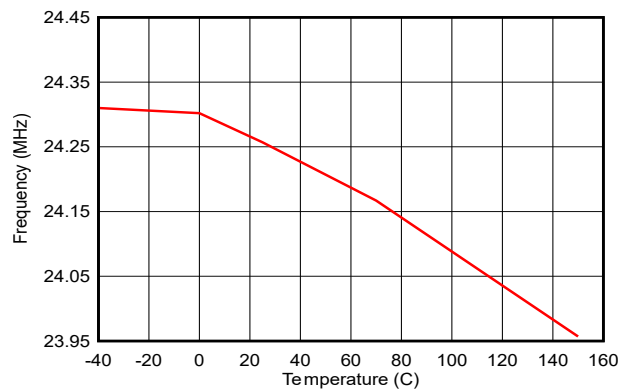


Figure 6-35. (M0) 24 MHz Oscillator vs Temperature

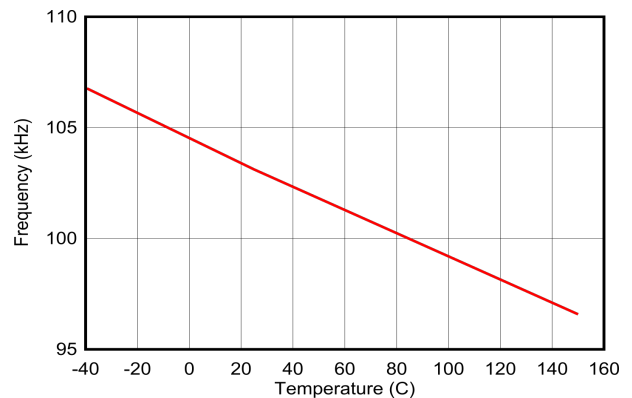


Figure 6-36. (M0) 100 kHz Oscillator vs Temperature

## 6.17 Typical Characteristics (continued)

At  $V_{IN} = 12\text{ V}$ ,  $f_{sw} = 400\text{ kHz}$ , unless otherwise stated.

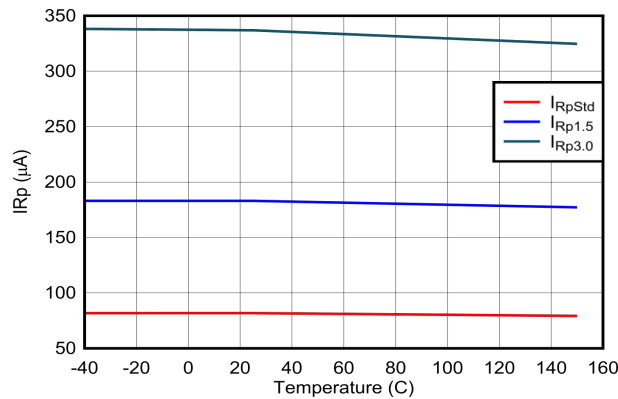


Figure 6-37. Type-C Cable Detect:  $I_{Rp}$  vs Temperature

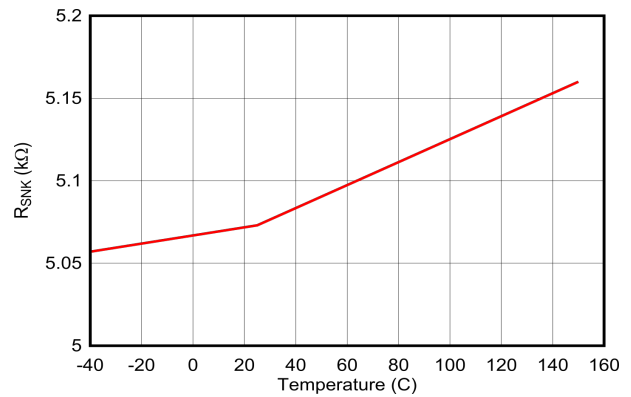


Figure 6-38. Type-C Cable Detect:  $R_{SNK}$  vs Temperature

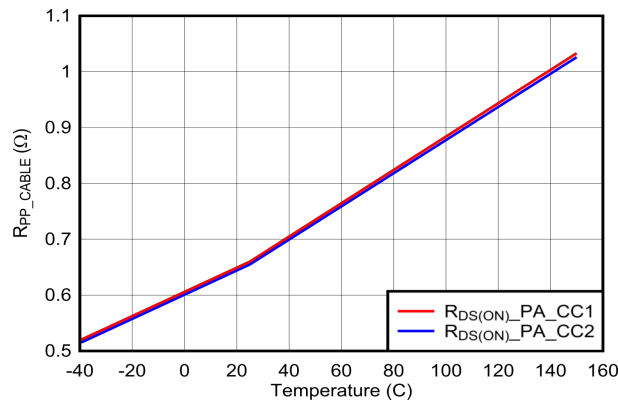


Figure 6-39.  $V_{CONN}$  Power Path:  $R_{DS(ON)}$  vs Temperature

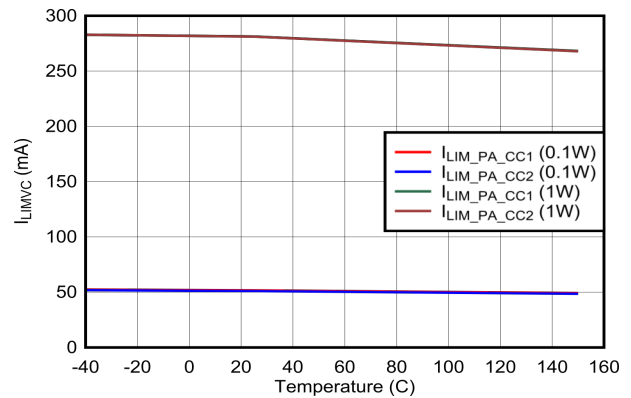


Figure 6-40.  $V_{CONN}$  Power Path: Current Limit vs Temperature

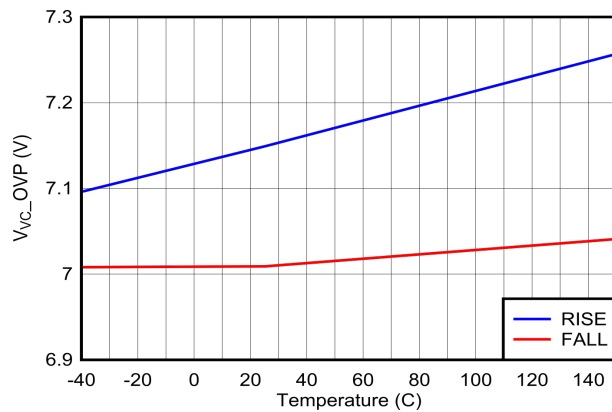


Figure 6-41. Type-C Cable Detect &  $V_{CONN}$ : Over-voltage Protection Thresholds vs Temperature

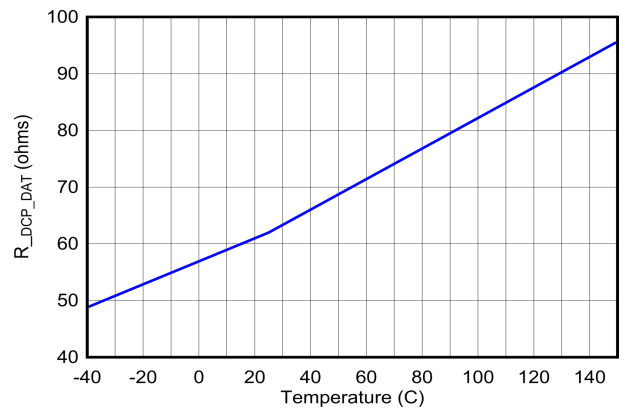
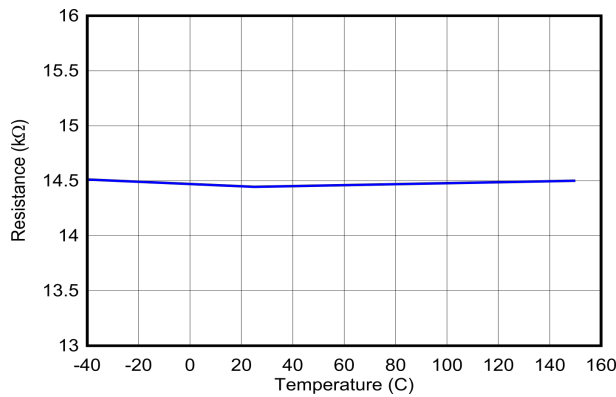


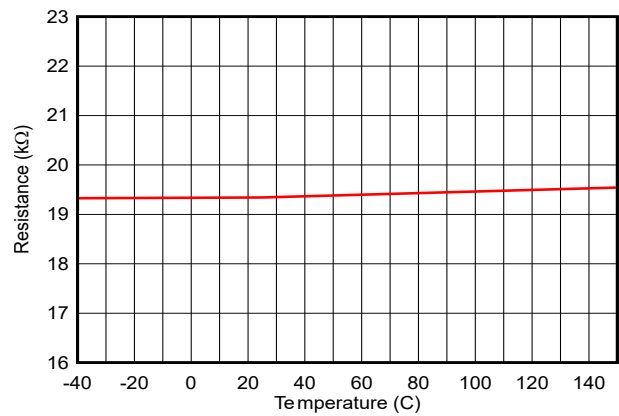
Figure 6-42. USB BC1.2: DP to DM Shorting Resistance,  $R_{DCP\_DAT}$

### 6.17 Typical Characteristics (continued)

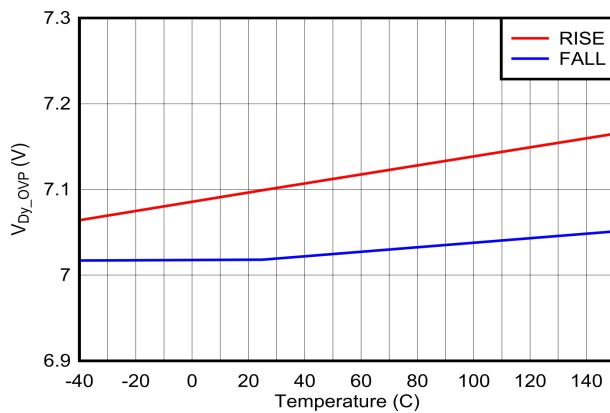
At  $V_{IN} = 12\text{ V}$ ,  $f_{sw} = 400\text{ kHz}$ , unless otherwise stated.



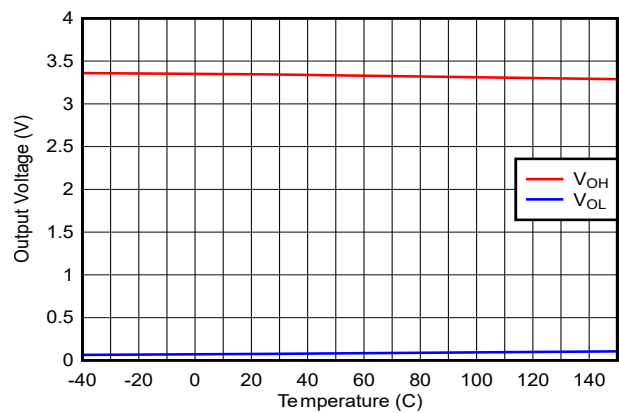
**Figure 6-43. USB BC1.2: DM to AGND 15 kΩ Resistance,  $R_{DM\_DWN\_15k}$**



**Figure 6-44. USB BC1.2: DM to AGND 20 kΩ Resistance,  $R_{DM\_DWN\_20k}$**

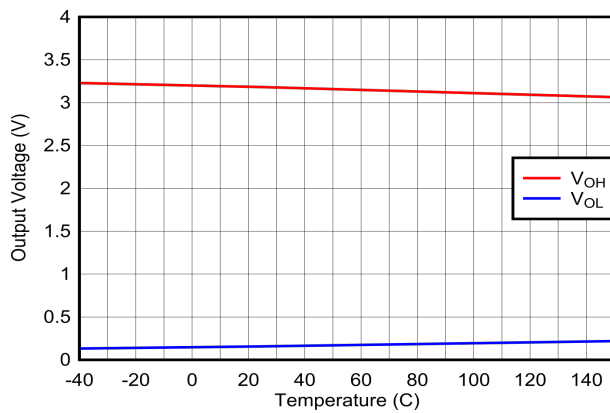


**Figure 6-45. USB BC1.2: DP and DM Pin Over-voltage Protection Thresholds vs Temperature**



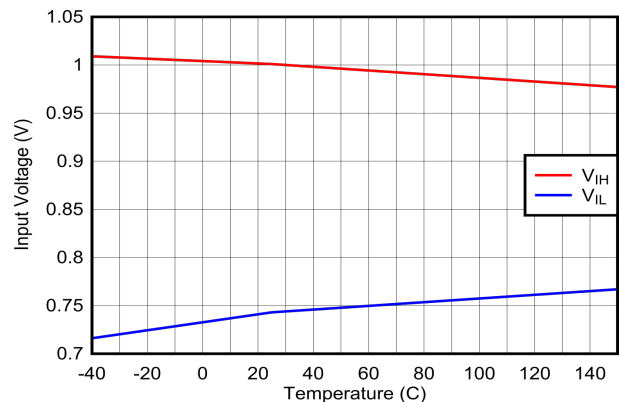
**GPIO 0, 1, 4, 7, 8, 9**  
 $I_O = \pm 2\text{ mA}$

**Figure 6-46. GPIO: Output Voltage vs Output Current and Temperature**



**GPIO 2, 3, 5, 6**  
 $I_O = \pm 5\text{ mA}$

**Figure 6-47. GPIO: Output Voltage vs Output Current and Temperature**



**Figure 6-48. GPIO: Input Voltage Thresholds vs Temperature**

## 7 Parameter Measurement Information

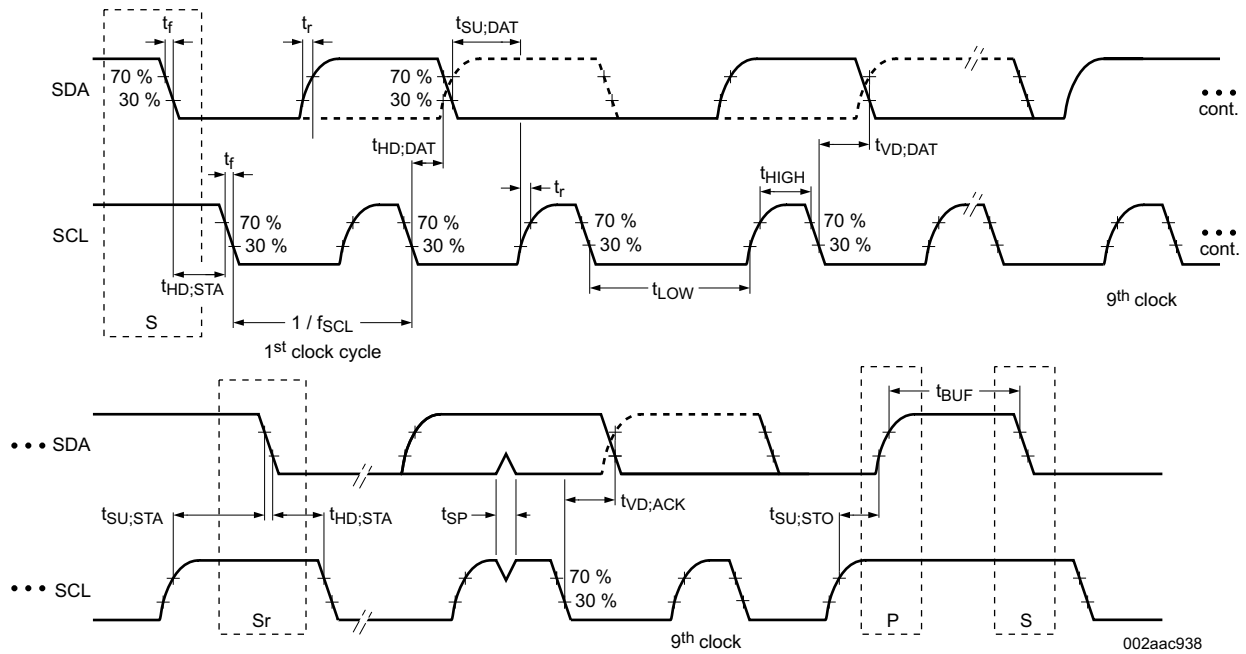


Figure 7-1. I<sup>2</sup>C Target Interface Timing

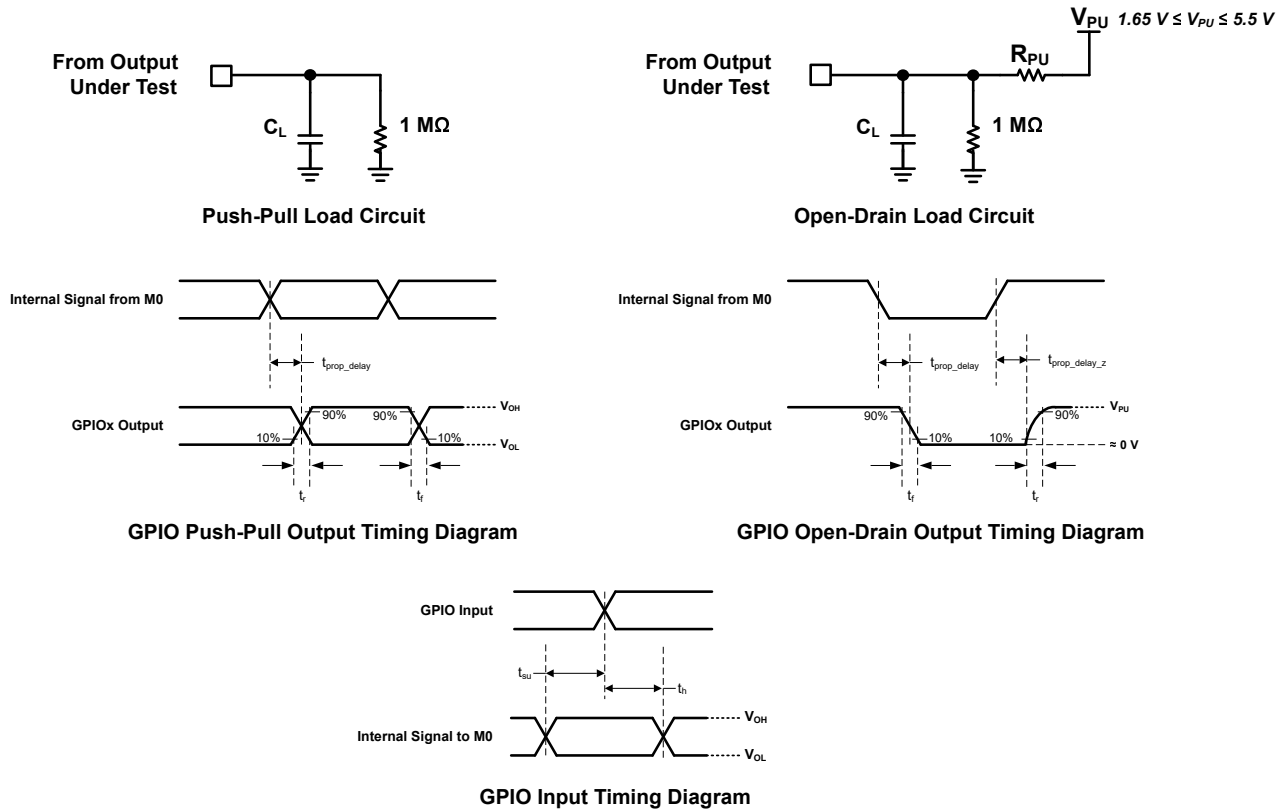
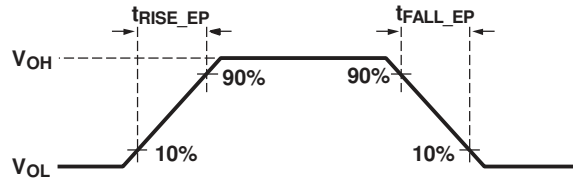
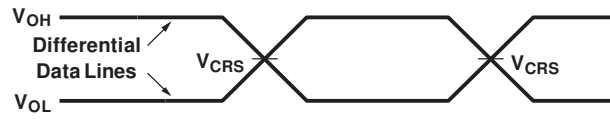


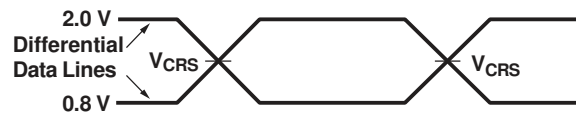
Figure 7-2. GPIO Output Timing Diagram (rise/fall vs capacitive load)



**Figure 7-3. USB Endpoint Transmitter Rise and Fall Time**



(a) Output Crossover Voltage



(b) Input Crossover Voltage

**Figure 7-4. USB Endpoint Crossover Voltages**

## 8 Detailed Description

### 8.1 Overview

The TPS25762-Q1 is a fully-integrated AEC-Q100 USB Power Delivery (USB-PD) source intended for use in 12-V automotive battery systems. Input supply pin,  $V_{IN}$ , must be connected to a load dump clamped battery supply,  $V_{BAT}$ , and never exceed 40 V (ABS MAX).

The device consists of seven sub-blocks: USB-PD controller; Type-C cable plug and orientation detection circuitry; USB Endpoint; USB Battery Charging Specification Version 1.2 (BC1.2) detection circuitry; digital core; device power management and supervisory circuitry; and a buck-boost converter with 4 integrated power switches.

The USB-PD controller provides the physical layer (PHY) functionality of the USB-PD protocol. The USB-PD data is output through either the Px\_CC1 pin or the Px\_CC2 pin, depending on the orientation of the reversible USB Type-C cable. For a high-level block diagram of the USB-PD physical layer, a description of its features and more detailed circuitry, see [USB-PD Physical Layer](#).

The cable plug and orientation detection analog circuitry automatically detects a USB Type-C cable plug insertion and also automatically detects the cable orientation. For a high-level block diagram of cable plug and orientation detection, a description of its features and more detailed circuitry, see [Cable Plug and Orientation Detection](#).

A USB Endpoint is included for downloading configuration information and firmware updates. When enabled by firmware, the USB Endpoint connects to the PA\_DP and PA\_DM pins.

The USB BC1.2 sub-block contains circuitry to support legacy USB charging methods which signal on the USB DP and DM data lines including: DCP, Divider-3, 1.2 V mode, and HVDCP. For additional detail, see [BC 1.2, legacy and fast charging modes \(Px\\_DP, Px\\_DM\)](#).

The power management and supervisory circuitry generates the LDO\_5V, LDO\_3V3, and LDO\_1V5 voltage rails used by the device. LDO\_5V supplies the LDO\_3V3 and LDO\_1V5 rails. For a high-level block diagram of the power management circuitry, a description of its features and more detailed operation, see [Internal LDO Regulators](#) section.

The digital core contains an ARM Cortex-M0 with 160-kB ROM and 27-kB RAM memory. The ROM contains firmware code to execute device functionality. RAM stores application configuration code created using a Graphical User Interface (GUI) and post-manufacturing firmware updates. The digital core is the engine for autonomously managing the system including: USB port connection status and communication; system power budget and allocation; system thermal monitoring and load shedding; and fault detection and reporting. All devices contain one controller I<sup>2</sup>C port (I<sup>2</sup>C1) for controlling external peripherals such as external EEPROM memory; DC/DC converters; USB data multiplexers/redrivers; GPIO expanders; and additional temperature sensors. Some devices include an I<sup>2</sup>C target port (I<sup>2</sup>C2) for connection to an external processor, HUB or embedded controller. An integrated 8-bit analog-to-digital converter ADC (see the [ADC](#) section) monitors USB port telemetry information. USB port connection status, voltage, current and fault information can be read from I<sup>2</sup>C2 target port. For a high-level block diagram of the digital core and a description of its features, see the [Digital Core](#) section.

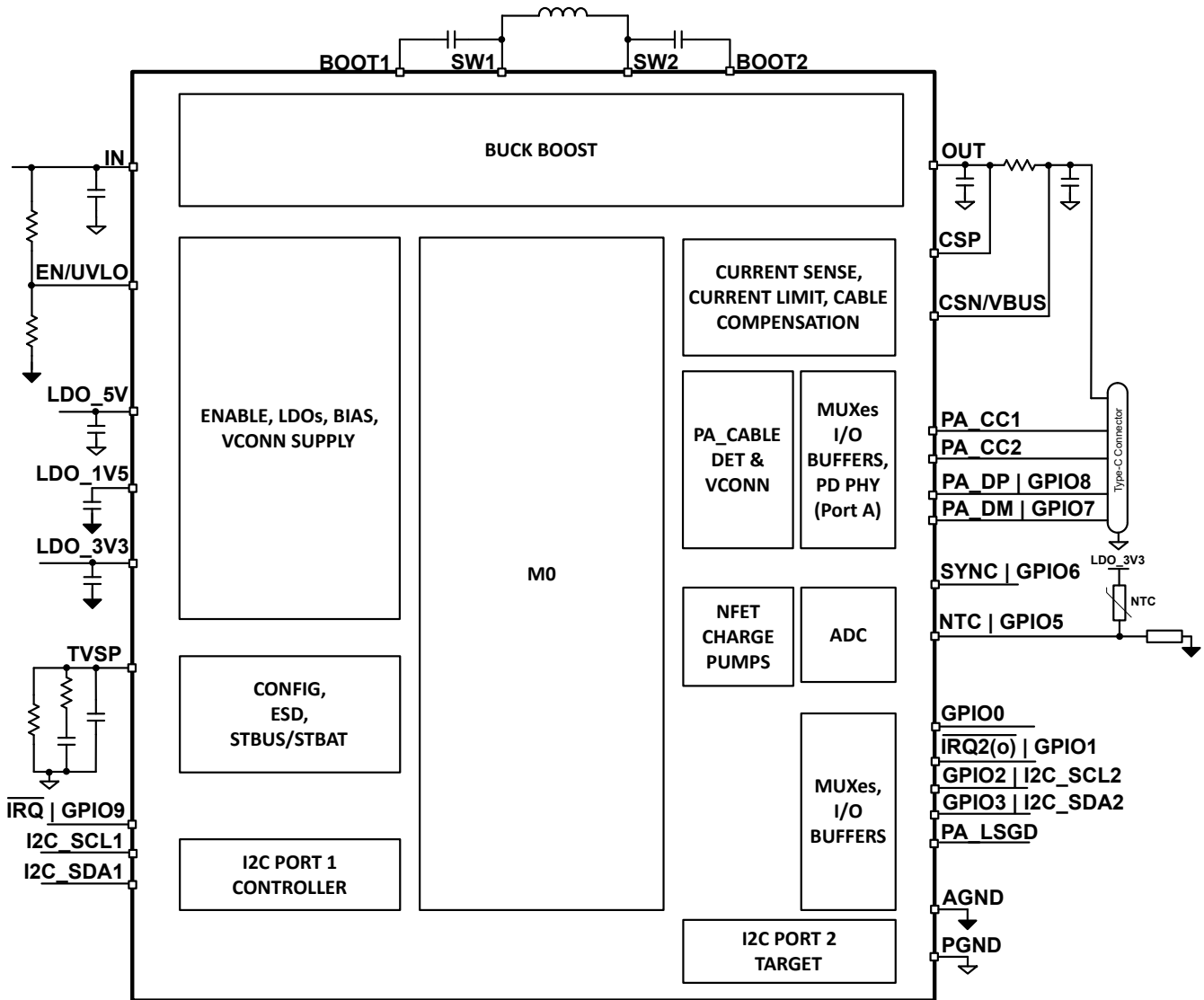
The integrated buck-boost DC/DC converter supplies the PA\_VBUS power source. The integrated DC/DC operates in buck mode when  $V_{IN}$  is greater than  $V_{OUT}$  and boost mode when  $V_{IN}$  is less than  $V_{OUT}$ . When  $V_{IN}$  and  $V_{OUT}$  are nearly the same, it operates in transition mode.

### Single Port Device

TPS25762-Q1 is a single USB-PD port device. Refer to [Device Comparison Table](#) for dual port options. The TPS25762-Q1 device consists of a single 3.3 to 21 V output internal buck-boost converter, one USB-PD port controller providing cable plug and orientation detection, one internal VCONN source path, legacy USB Battery Charging Specification v1.2 Dedicated Charging Port (DCP) as well as legacy (non-USB compliant) charger detection including: Divider-3, 1.2 V, and HVDCP modes. The TPS25762-Q1 device communicates with its

connected USB Type-C cable and downstream USB device at the opposite end of the cable to determine connection state and enables VBUS sourcing as appropriate.

## 8.2 Functional Block Diagram



## 8.3 Feature Description

### 8.3.1 Device Power Management and Supervisory Circuitry

#### 8.3.1.1 VIN UVLO and Enable/UVLO

The TPS25762-Q1 has one internally fixed  $V_{IN}$  UVLO and one user programmable UVLO using the EN/UVLO pin. Both thresholds must be cleared for the device to start up.

- The fixed  $V_{IN(UVLO)}$  has a rising threshold between 5 and 5.5 V to ensure internal circuits have sufficient headroom for proper operation.
- The EN/UVLO pin provides the user with a resistor programmable UVLO threshold and master enable / disable for the device.

The EN/UVLO pin has three distinct voltage ranges: shutdown, standby, and operating. When the EN/UVLO pin is below the standby threshold  $V_{EN(STBY)}$ , the device is disabled in a low power shutdown. When EN/UVLO voltage is greater than the standby threshold  $V_{EN(STBY)}$  but less than the operating threshold  $V_{EN(OPER)}$ , the internal bias rails, LDO\_5V, LDO\_3V3, and LDO\_1V5 regulators are enabled but remaining device functions

are disabled. When EN/UVLO is greater than the operating threshold  $V_{EN(OPER)}$  and LDO\_5V, LDO\_3V3 and LDO\_1V5 regulators are above their respective undervoltage threshold UVLO thresholds, the device is fully functional. The EN/UVLO pin includes fixed hysteresis between the shutdown mode and the standby mode.

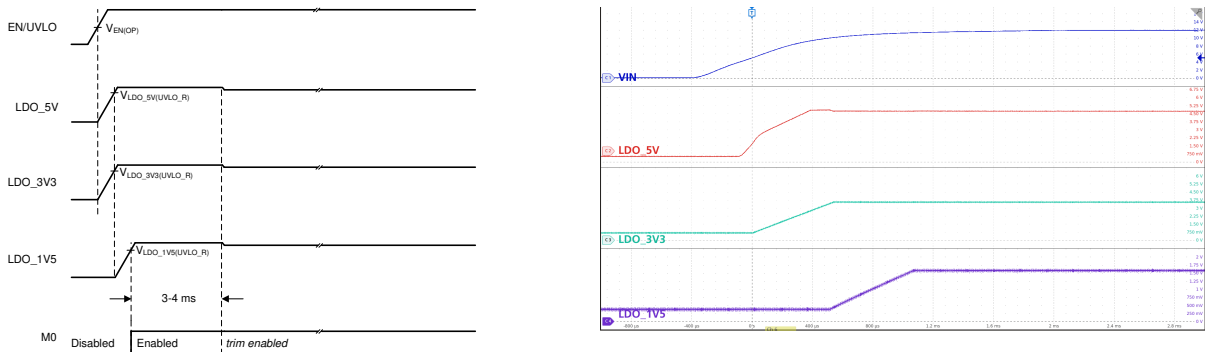


Figure 8-1. EN/UVLO and LDO Sequencing

Table 8-1. EN/UVLO and LDO\_UVLO Operation

EN/UVLO (1)	LDOs	DEVICE OPERATION
$V_{EN/UVLO} < V_{EN(LDO\_V5\_F)}$	—	Shutdown: LDO_5V, LDO_3V3 and LDO_1V5 OFF. M0 (MCU) is OFF.
$V_{EN(LDO\_V5\_R)} < V_{EN/UVLO} < V_{EN(STBY)}$	—	Standby: LDO_5V, LDO_3V3 and LDO_1V5 ON. M0 (MCU) is OFF.
$V_{EN/UVLO} > V_{EN(OPER)}$	LDO_5V < $V_{LDO\_5V(UVLO\_R)}$ , or LDO_3V3 < $V_{LDO\_3V3(UVLO\_R)}$ ; or LDO_1V5 < $V_{LDO\_1V5(UVLO\_R)}$	LDO_5V, LDO_3V3 and LDO_1V5 ON, M0 (MCU) is OFF.
$V_{EN/UVLO} > V_{EN(OPER)}$	LDO_5V > $V_{LDO\_5V(UVLO\_R)}$ , and LDO_3V3 > $V_{LDO\_3V3(UVLO\_R)}$ , and LDO_1V5 > $V_{LDO\_1V5(UVLO\_R)}$	Operating: M0 (MCU) is ON.

(1) Valid when  $V_{IN} > V_{IN(UVLO\_R)}$ .

In some cases an input UVLO level different than that provided by the internal  $V_{IN(UVLO)}$  is needed and can be accomplished by using the circuit shown in [UVLO Threshold Programming](#). The input voltage at which the device turns on is designated  $V_{ON}$ ; while the turnoff voltage is  $V_{OFF}$ . First a value for  $R_{ENB}$  is chosen in the range of 13 kΩ to 22 kΩ. Use [Equation 1](#) and [Equation 2](#) to calculate  $R_{ENT}$  and  $V_{OFF}$ .

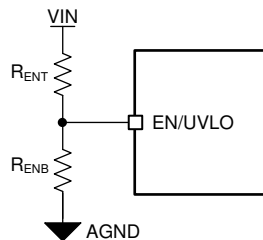


Figure 8-2. UVLO Threshold Programming

$$R_{ENT} = \left( \frac{V_{ON}}{V_{EN(OPER)}} - 1 \right) \times R_{ENB} \quad (1)$$

The hysteresis between the UVLO turn-on threshold and turn-off threshold is set by the upper resistor in the EN/UVLO resistor divider and is given by:

$$V_{\text{OFF}} = \left(1 - \frac{V_{\text{EN(HYS)}}}{V_{\text{EN(OPER)}}}\right) \times V_{\text{ON}} \quad (2)$$

Where

- $V_{\text{ON}} = V_{\text{IN}}$  turn-on voltage
- $V_{\text{OFF}} = V_{\text{IN}}$  turn-off voltage

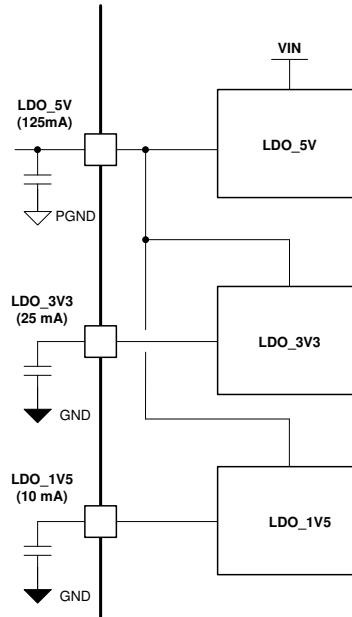
**Note:** Ensure  $R_{\text{ENT}} \geq 47 \text{ k}\Omega$

If the programmable UVLO is not required, the EN/UVLO pin can be connected to the IN pin with a 47 k $\Omega$ , or larger, resistor.

### 8.3.1.2 Internal LDO Regulators

Three internal LDOs provide regulated supplies for operation of internal circuitry.

- **LDO\_5V:** Supplies buck-boost gate drive circuitry, LDO\_3V3, LDO\_1V5, and PA and PB VCONN power paths. External bypass capacitance,  $C_{\text{LDO}_5\text{V}}$  is required for proper operation. It is highly recommended to include an additional high frequency 0.1  $\mu\text{F}$  capacitor in parallel with  $C_{\text{LDO}_5\text{V}}$ . In the design, place  $C_{\text{LDO}_5\text{V}}$  and the parallel high frequency capacitor as close to the LDO\_5V pin as possible. This capacitance: 1) provides energy storage for the buck-boost internal FET gate drivers, and 2) is required to stabilize the internal 5-V LDO in applications where an external 5-V supply is not connected. The TPS25762-Q1 does not operate (release reset) until  $V_{\text{LDO}_5\text{V(UVLO}_R)}$  threshold is met. Hard reset occurs when  $V_{\text{LDO}_5\text{V}} < V_{\text{LDO}_5\text{V(UVLO}_F)}$  threshold. Current from LDO\_5V returns to PGND pin. The LDO\_5V output may be used to supply a small external loads such as indicator LEDs. When supplying external components, it is recommended that the total external load current not exceed 25 mA (MAX).
  - 0.1W VCONN: when enabled in the application configuration GUI, LDO\_5V is capable of sourcing 20 mA each to PA\_VCONN and PB\_VCONN.
  - 1W VCONN: when enabled in the application configuration GUI, this mode of operation *requires* an external 4.75 - 5.5 V, 500-mA capable supply connected to LDO\_5V. Back-feeding of LDO\_5V is allowed.
- **LDO\_3V3:** Supplies internal analog circuits, GPIO buffers, USB PD and the USB Endpoint PHYs. External bypass capacitance of  $C_{\text{LDO}_3\text{V3}}$  is required for proper operation. An additional 0.1  $\mu\text{F}$  capacitor in parallel with  $C_{\text{LDO}_3\text{V3}}$  is highly recommended to filter high frequency noise from the I/O buffers and PHYs. The LDO\_3V3 can supply external circuits at up to 25 mA. Expected loads include: EEPROM (5mA), NTC resistor divider network (< 1 mA). Current may be drawn up to  $I_{\text{LDO}_3\text{V3(ILIMIT)}}$ . Note: the USB PD and Endpoint PHYs draw current from LDO\_3V3. If a CCx or Dx pin is shorted to GND during a transmission the current drawn may reach the current limit threshold. Similarly, if any GPIO pins are configured as push-pull outputs and a GPIO short to GND event occurs, the LDO\_3V3 current limit may be reached. Current returns to AGND pin.
- **LDO\_1V5:** Supplies digital core. External bypass capacitance of  $C_{\text{LDO}_1\text{V5}}$  is required for proper operation. An additional 0.1  $\mu\text{F}$  capacitor in parallel with  $C_{\text{LDO}_1\text{V5}}$  is highly recommended to filter noise generated by the digital core. The M0 is held in reset until all three UVLO\_R (rising) thresholds are met. Current returns to AGND pin.



Note: LDO\_5V max regulation current includes LDO\_3V3 (25 mA) and LDO\_1V5 (10 mA)

**Figure 8-3. Internal LDO Connection Diagram**

### 8.3.2 TVSP Device Configuration and ESD Protection

The Transient Voltage protection and firmware **Setting Pin (TVSP)** has three functions: 1) Boot configuration settings; 2) USB connector pin short to  $V_{BUS}$  or  $V_{BAT}$  protection; and 3) USB connector pin enhanced ESD protection.

- **$R_{TVSP}$ :** At power on, the resistance between the TVSP pin and PGND determines the boot method, USB PD port I<sup>2</sup>C addresses and I<sup>2</sup>C logic thresholds. Resistor values are device-specific; refer to [Table 8-5](#). The most common configuration is shown in [Basic TVSP Pin Connection](#) with  $R_{TVSP}$  open, corresponding to TVSP Index 0. During device initialization and boot, typically within 4 seconds after power on,  $V_{IN}$  must be above 7.6 V to ensure proper bias of the TVSP pin to 5.5 V. Once boot is complete the device can operate over the full  $V_{IN}$  range.
- **$C_{TVSP}$ :** A 0.1- $\mu$ F capacitor ( $C_{TVSP}$ ) *must* be connected to PGND. Place  $C_{TVSP}$  as close to the TVSP pin as possible to minimize parasitic inductance.  $C_{TVSP}$  is part of the centralized protection circuitry fortifying connector pins Px\_CCy, Px\_DP and Px\_DM from damage during short to  $V_{BUS}$ ,  $V_{BAT}$  and ESD events. A 40-V 0.1- $\mu$ F capacitor is recommended for proper operation of the internal TVSP regulator circuit.
- **TVSP Damper Network:** Capacitance,  $C_{DAMP}$ , and resistance,  $R_{DAMP}$ , form an RC network preventing excessive current from flowing inside the device during connector pin over-voltage and ESD events.
  - **$C_{DAMP}$ :** A 0.47- $\mu$ F capacitor *must* be connected in series with  $R_{DAMP}$  to PGND. A 40-V 0.47- $\mu$ F capacitor is recommended.
  - **$R_{DAMP}$ :** A 10- $\Omega$  resistor *must* be connected in series with  $C_{DAMP}$  to PGND. A 0.25-W rating is recommended.

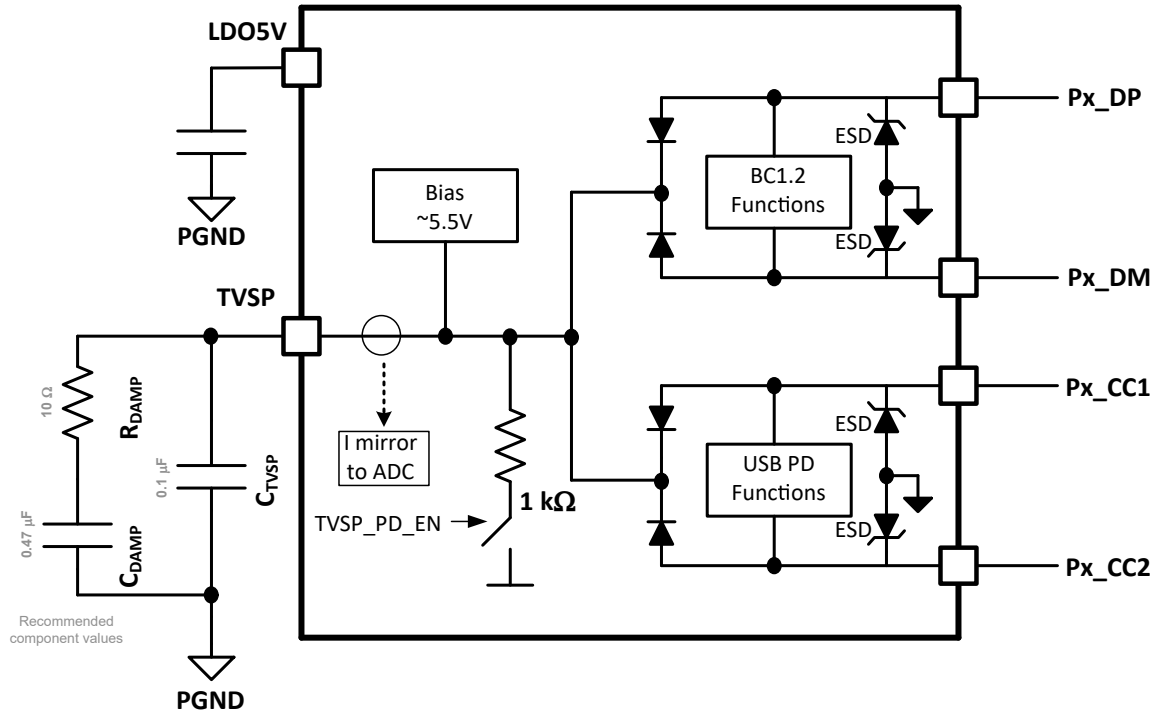


Figure 8-4. Basic TVSP Pin Connection

Table 8-2. Recommended TVSP Components

C <sub>TVSP</sub>	R <sub>DAMP</sub>	C <sub>DAMP</sub>
0.1 μF	10 Ω	0.47 μF

Table 8-3. R<sub>TVSP</sub> Configuration Settings (TPS257xxCQRQLRQ1)

R <sub>TVSP</sub> (kΩ) <sup>(1)</sup>	TVSP Index	ADC Value	I2C Target Port Addresses (A   B) <sup>(2)</sup>	I2C Logic (V <sub>DD</sub> )	Boot Mode
Open	0	≤ 10 (0x0A)	0x22   0x26	3.3 V	EEPROM
93.1	1	≤ 24 (0x18)	0x23   0x27	3.3 V	External HUB/MCU
47.5	2	≤ 42 (0x2A)	0x22   0x26	1.8 V	EEPROM
29.4	3	≤ 63 (0x3F)	0x23   0x27	1.8 V	External HUB/MCU
20.0	4	≤ 89 (0x59)	0x23   0x27	3.3 V	EEPROM
14.7	5	≤ 119 (0x77)	0x22   0x26	3.3 V	External HUB/MCU
11.0	6	≤ 156 (0x9C)	0x23   0x27	1.8 V	EEPROM
8.45	7	≤ 201 (0xC9)	0x22   0x26	1.8 V	External HUB/MCU
6.65	8	≤ 255 (0xFF)	0x22   0x26	3.3 V	Firmware Update

Table 8-4. R<sub>TVSP</sub> Configuration Settings (TPS257xxCAQRQLRQ1)

R <sub>TVSP</sub> (kΩ)	TVSP Index	ADC Value	I2C Target Port Addresses (A   B)	I2C Logic (V <sub>DD</sub> )	Boot Mode
Open	0	≤ 10 (0x0A)	0x22   0x26	3.3 V	EEPROM
5.6	8	≤ 255 (0xFF)	0x22   0x26	3.3 V	Firmware Update

Table 8-5. R<sub>TVSP</sub> Configuration Settings (TPS257xxDQRQLRQ1)

R <sub>TVSP</sub> (kΩ) <sup>(1)</sup>	TVSP Index	ADC Value	I2C Target Port Addresses (A   B) <sup>(2)</sup>	I2C Logic (V <sub>DD</sub> )	Boot Mode
Open	0	≤ 10 (0x0A)	0x22   0x26	3.3 V	EEPROM
93.1	1	≤ 24 (0x18)	0x23   0x27	3.3 V	External HUB/MCU
47.5	2	≤ 42 (0x2A)	0x22   0x26	1.8 V	EEPROM

**Table 8-5. R<sub>TVSP</sub> Configuration Settings (TPS257xxDQRQLRQ1) (continued)**

R <sub>TVSP</sub> (kΩ) <sup>(1)</sup>	TVSP Index	ADC Value	I2C Target Port Addresses (A   B) <sup>(2)</sup>	I2C Logic (V <sub>DD</sub> )	Boot Mode
26.7	3	≤ 63 (0x3F)	0x23   0x27	1.8 V	External HUB/MCU
18.2	4	≤ 89 (0x59)	0x23   0x27	3.3 V	EEPROM
13.0	5	≤ 119 (0x77)	0x22   0x26	3.3 V	External HUB/MCU
9.53	6	≤ 156 (0x9C)	0x23   0x27	1.8 V	EEPROM
7.5	7	≤ 201 (0xC9)	0x22   0x26	1.8 V	External HUB/MCU
5.6	8	≤ 255 (0xFF)	0x22   0x26	3.3 V	Firmware Update

(1) 1% resistor required.

(2) 0x22h = 0100010; 0x26h = 0100110; 0x23h = 0100011; 0x27 = 0100111

For the TPS25762D-Q1 device, a factory-programmed default application configuration is applied at power-up. The default configuration is applied when the boot mode is configured for EEPROM and the EEPROM configuration is not loaded; for example when the image provided by the EEPROM is not valid or the EEPROM is not connected. When the default application configuration is loaded, the maximum port output power (port PDP) is configured using the TVSP index as defined by R<sub>TVSP</sub>. Valid TVSP indexes for this mode of operation are shown in R<sub>TVSP</sub> Port Maximum PDP Selection (TPS25762DQRQLRQ1 and TPS25772DQRQLRQ1).

**Table 8-6. R<sub>TVSP</sub> Port Maximum PDP Selection (TPS25762DQRQLRQ1 and TPS25772DQRQLRQ1)**

R <sub>TVSP</sub> (kΩ)	TVSP Index	ADC Value	I2C Target Port Addresses (A   B)	I2C Logic (V <sub>DD</sub> )	Port Maximum PDP
Open	0	≤ 10 (0x0A)	0x22   0x26	3.3 V	60 W
47.5	2	≤ 42 (0x2A)	0x22   0x26	1.8 V	45 W
18.2	4	≤ 89 (0x59)	0x23   0x27	3.3 V	27 W
9.53	6	≤ 156 (0x9C)	0x23   0x27	1.8 V	15 W

The device settings when the default application configuration is loaded are defined by [Table 8-7](#).

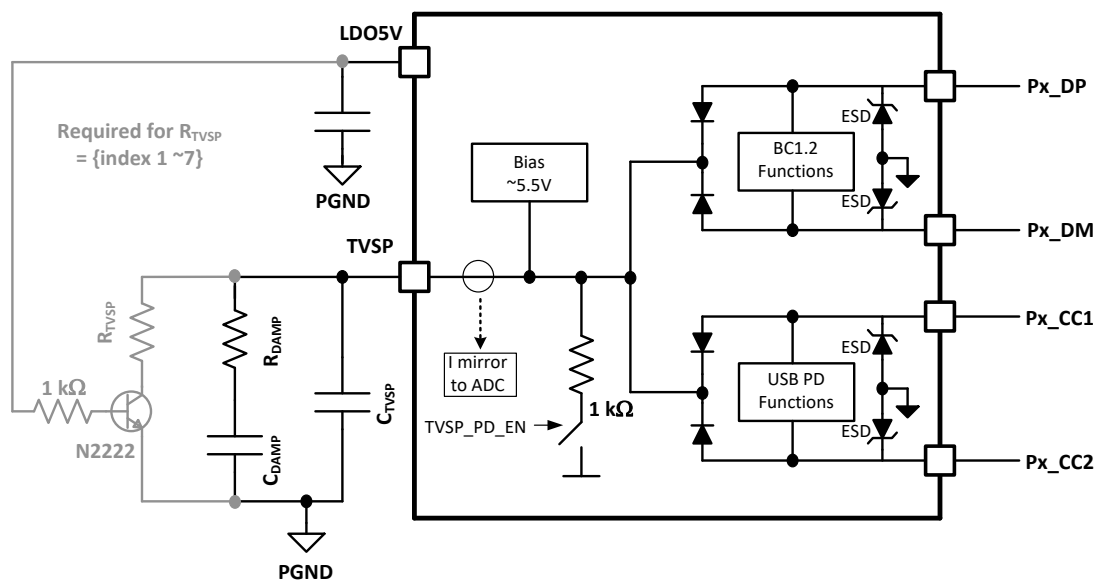
**Table 8-7. Default Application Configuration (TPS25762DQRQLRQ1 and TPS25772DQRQLRQ1)**

Parameter	TPS25762DQRQLRQ1	TPS25772DQRQLRQ1	Comment
XID	0x00	0x00	
PID	0x00	0x00	
VID	0x0451	0x0451	TI VID
Port Min Power	7.5W	7.5W	Applies to all ports
Port Max Power	60W/45W/27W/15W	60W/45W/27W/15W	Set by TVSP Index; applies to all ports
System Max Power	60W/45W/27W/15W	Port Max Power x 2	
Port PPS	Enabled	Enabled	Applies to all ports
SPM Power Policy	n/a	Assured Capacity	
BC1.2	Enabled	Enabled	Applies to all ports
External DCDC	n/a	TPS55288-Q1	
Port A ILIM Overshoot	400 mA	400 mA	
Port A APDO ILIM Overshoot	50 mA	50 mA	
Port A Cable Compensation	Disabled	Disabled	
Port A High ILIM Delay	Enabled	Enabled	
Port B ILIM Overshoot	n/a	400 mA	
Port B APDO ILIM Overshoot	n/a	50 mA	
Port B Cable Compensation	n/a	External	Set by external DCDC
Port B VBUS Boost	n/a	0.1 V	
Port B Discharge	n/a	Enabled	External, controlled by GPIO9

**Table 8-7. Default Application Configuration (TPS25762DQRQLRQ1 and TPS25772DQRQLRQ1)  
(continued)**

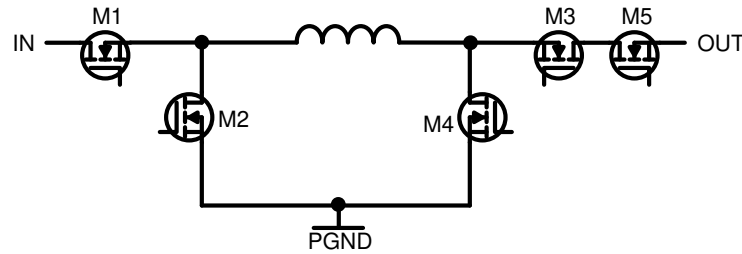
Parameter	TPS25762DQRQLRQ1	TPS25772DQRQLRQ1	Comment
Internal DCDC Freq	400 kHz	400 kHz	
Internal DCDC Dither	10 Hz	10 Hz	
Grace Period Power ON	15 min	15 min	
Grace Period Power OFF	15 min	15 min	
Range 3 Power	FULL	FULL	
Range 2 Power	60%	60%	% of System Max Power
Range 1 to 2 Rising Threshold	8.96 V	8.96 V	Measured at VIN
Range 2 to 1 Falling Threshold	7.04 V	7.04 V	Measured at VIN
Range 2 to 3 Rising Threshold	11.52 V	11.52 V	Measured at VIN
Range 3 to 2 Falling Threshold	10.08 V	10.08 V	Measured at VIN
Thermal Foldback	Enabled	Enabled	NTC/PTC configuration
Phase 1 Max Power	60%	60%	% of System Max Power
Phase 1 Rising Threshold	2.044 V	2.044 V	
Phase 1 Falling Threshold	1.988 V	1.988 V	
Phase 2 Max Power	30%	30%	% of System Max Power
Phase 2 Rising Threshold	2.1 V	2.1 V	
Phase 2 Falling Threshold	2.044 V	2.044 V	
Phase 3 Max Power	0%	0%	% of System Max Power
Phase 3 Rising Threshold	2.142 V	2.142 V	
Phase 3 Falling Threshold	2.086 V	2.086 V	

Applications requiring a configuration other than TVSP Index 0 ( $R_{TVSP}$  open), as shown in R TVSP Configuration Settings (TPS257xxCQRQLRQ1) and R TVSP Configuration Settings (TPS257xxDQRQLRQ1) must implement a circuit similar to the one shown in Figure 8-5. The base of the bipolar transistor is connected to LDO\_5V to provide proper power up sequencing of the TVSP resistor - OFF when TPS25762-Q1 is disabled and ON when TPS25762-Q1 is enabled. A 2N2222 is recommended for its large collector-emitter breakdown voltage, low-cost and wide availability.



**Figure 8-5.  $R_{TVSP}$  Circuit Configuration**



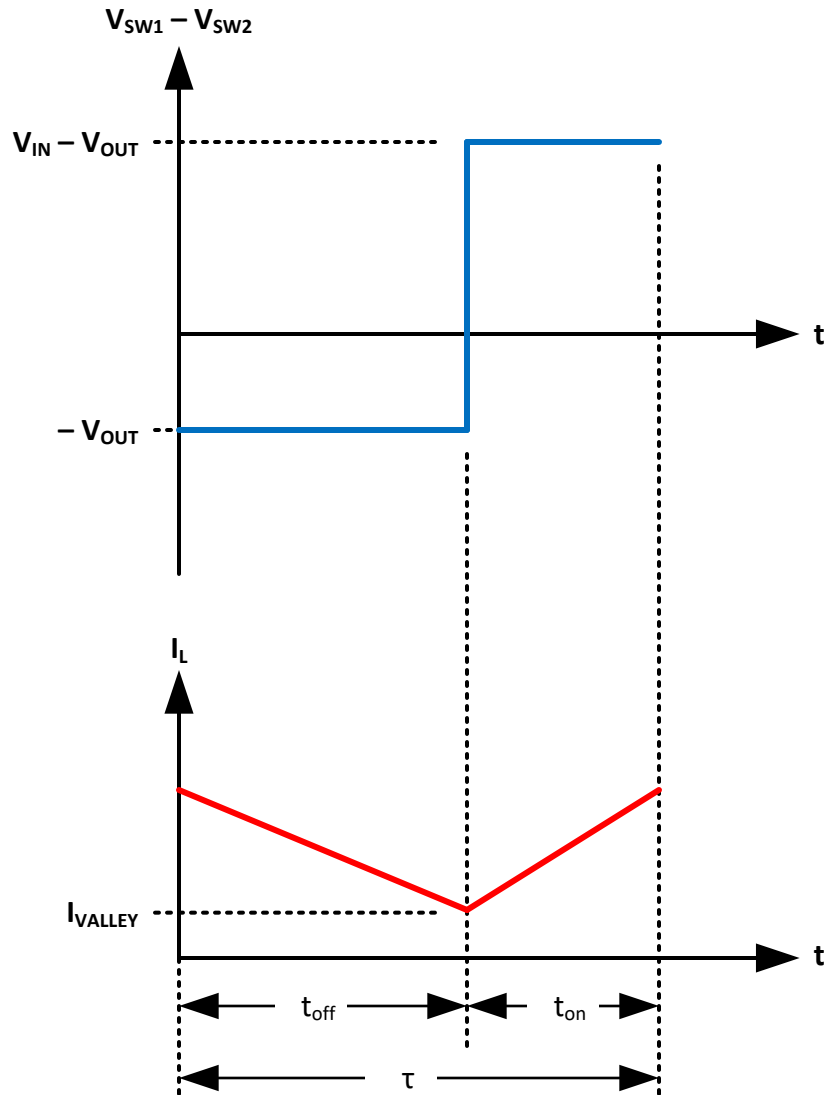


**Figure 8-7. Buck-Boost Internal Power FETs**

### Buck State

When the input voltage  $V_{IN}$  significantly exceeds the output voltage  $V_{OUT}$ , the converter enters the buck region of operation in which it performs an endless series of buck switching cycles **Buck State**. M3 and M5 are constantly on and M4 is constantly off. When the clock signals that a switching cycle has begun, the controller turns on M2 and turns off M1. This switch configuration corresponds to the off-time interval of a traditional buck converter. The voltage difference  $V_{SW1} - V_{SW2}$  across the inductor equals  $-V_{OUT}$ . The inductor current  $I_L$  ramps down until it reaches a threshold  $I_{VALLEY}$  set by the error amplifiers. The controller then turns off M2 and turns on M1. This switch configuration corresponds to the on-time interval of a traditional buck converter. The voltage difference  $V_{SW1} - V_{SW2}$  now equals  $V_{IN} - V_{OUT}$ . The inductor current now ramps up until the converter clock signals that the end of the switching cycle has been reached.

The on-time  $t_{on}$  equals the time interval during which M1 conducts. The off-time  $t_{off}$  equals the time interval during which M2 conducts. Because the converter operates in FCCM, the period  $\tau$  equals the sum of  $t_{on}$  and  $t_{off}$ . During the buck state, the controller regulates power flow by adjusting the buck duty cycle  $D$ , which equals the ratio  $t_{on}/\tau$ .



**Figure 8-8. Buck State**

### Buck Transition State

When the input voltage  $V_{IN}$  is only slightly larger than the output voltage  $V_{OUT}$ , the converter enters the buck transition region of operation in which it alternately performs buck and boost switching cycles [Buck Transition](#). M5 is always on. When the clock signals that a buck switching cycle has begun, the controller turns on M2 and M3, and it turns off M1 and M4. This switch configuration corresponds to the off-time of a traditional buck converter. The inductor current  $I_L$  ramps down until it reaches a threshold  $I_{VALLEY}$  set by the error amplifiers. The controller then turns off M2 and turns on M1. This switch configuration corresponds to the on-time of a traditional buck converter. The inductor current now ramps up slowly until the clock signals the end of the buck switching cycle. The next switching cycle is a boost switching cycle. When this cycle begins, the controller turns M3 off and turns M4 on. M2 remains off, and both M1 and M5 remain on. This switch configuration corresponds to the on-time of a traditional boost converter. The inductor current  $I_L$  now ramps up rapidly until the fixed on-time expires. The controller then turns off M4 and turns on M3. The inductor current now ramps down until the clock signals the end of the boost switching cycle. The next switching cycle is another buck cycle.

During the buck transition state, the controller regulates power flow by adjusting the buck duty cycle. The boost duty cycle remains fixed. If the converter remains in the buck state rather than move to the buck transition state, the buck on-time becomes so short that it is impossible to regulate power flow without pulse skipping.

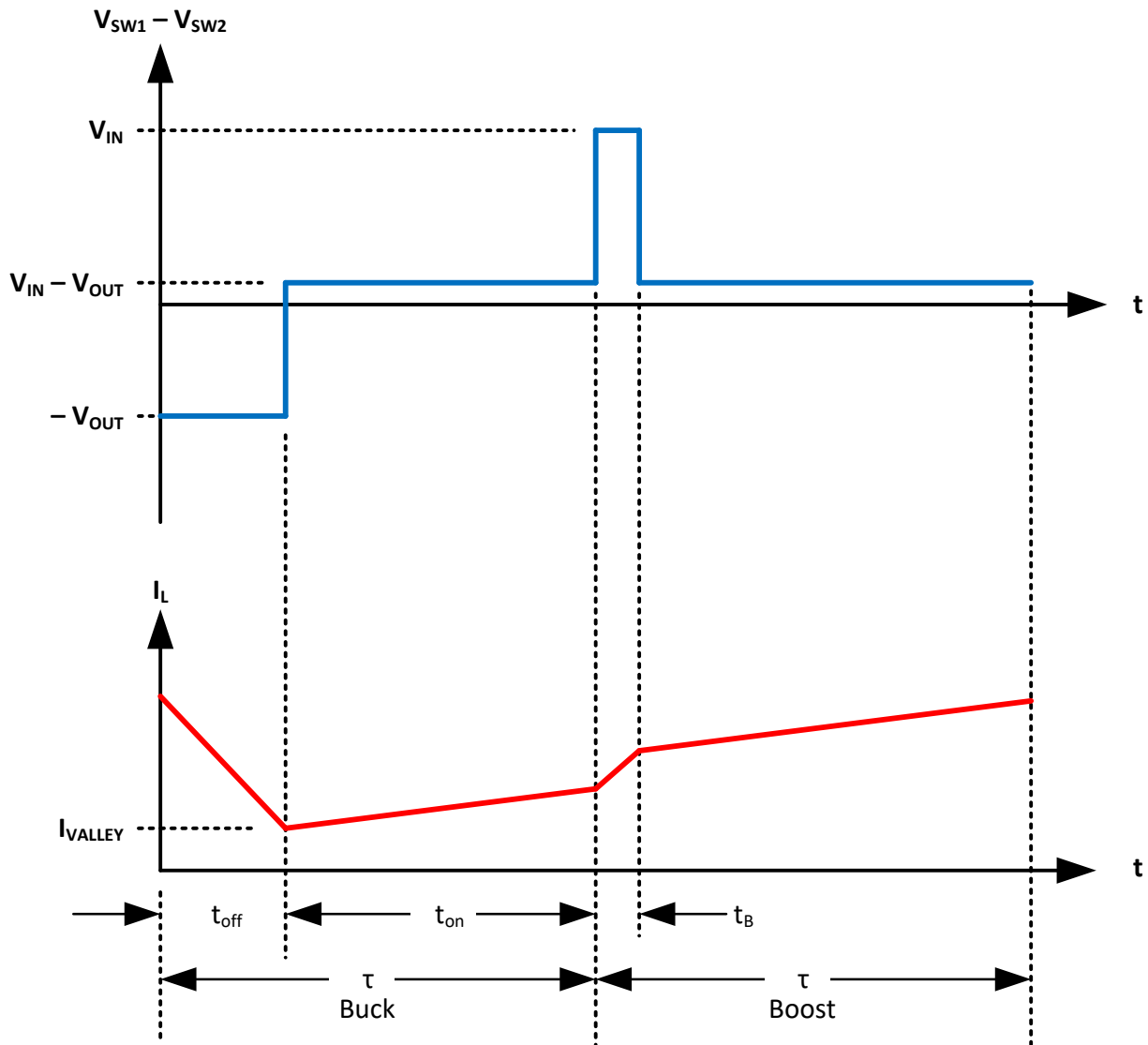


Figure 8-9. Buck Transition

### Boost Transition State

When the input voltage  $V_{IN}$  is only slightly smaller than the output voltage  $V_{OUT}$ , the converter enters the boost transition region of operation in which it alternately performs boost and buck switching cycles [Boost Transition](#). M5 is always on. When the clock signals that a boost switching cycle has begun, the controller turns on M1 and M4, and it turns off M2 and M3. This switch configuration corresponds to the on-time of a traditional boost converter. The inductor current  $I_L$  ramps up until it reaches a threshold  $I_{PEAK}$  set by the error amplifiers. The controller then turns off M4 and turns on M3. This switch configuration corresponds to the off-time of a traditional boost converter. The inductor current now ramps down slowly until the clock signals the end of the boost switching cycle. The next switching cycle is a buck switching cycle. When this cycle begins, the controller turns M1 off and turns M2 on. M4 remains off, and both M3 and M5 remain on. This switch configuration corresponds to the off-time of a traditional buck converter. The inductor current  $I_L$  now ramps down rapidly until the fixed

off-time expires. The controller then turns off M2 and turns on M1. The inductor current now ramps up until the clock signals the end of the buck switching cycle. The next switching cycle is another boost cycle.

During the boost transition state, the controller regulates power flow by adjusting the boost duty cycle. The buck duty cycle remains fixed. If the converter remains in the boost state rather than move to the boost transition state, the boost on-time is so short that it is impossible to regulate power flow without pulse skipping.

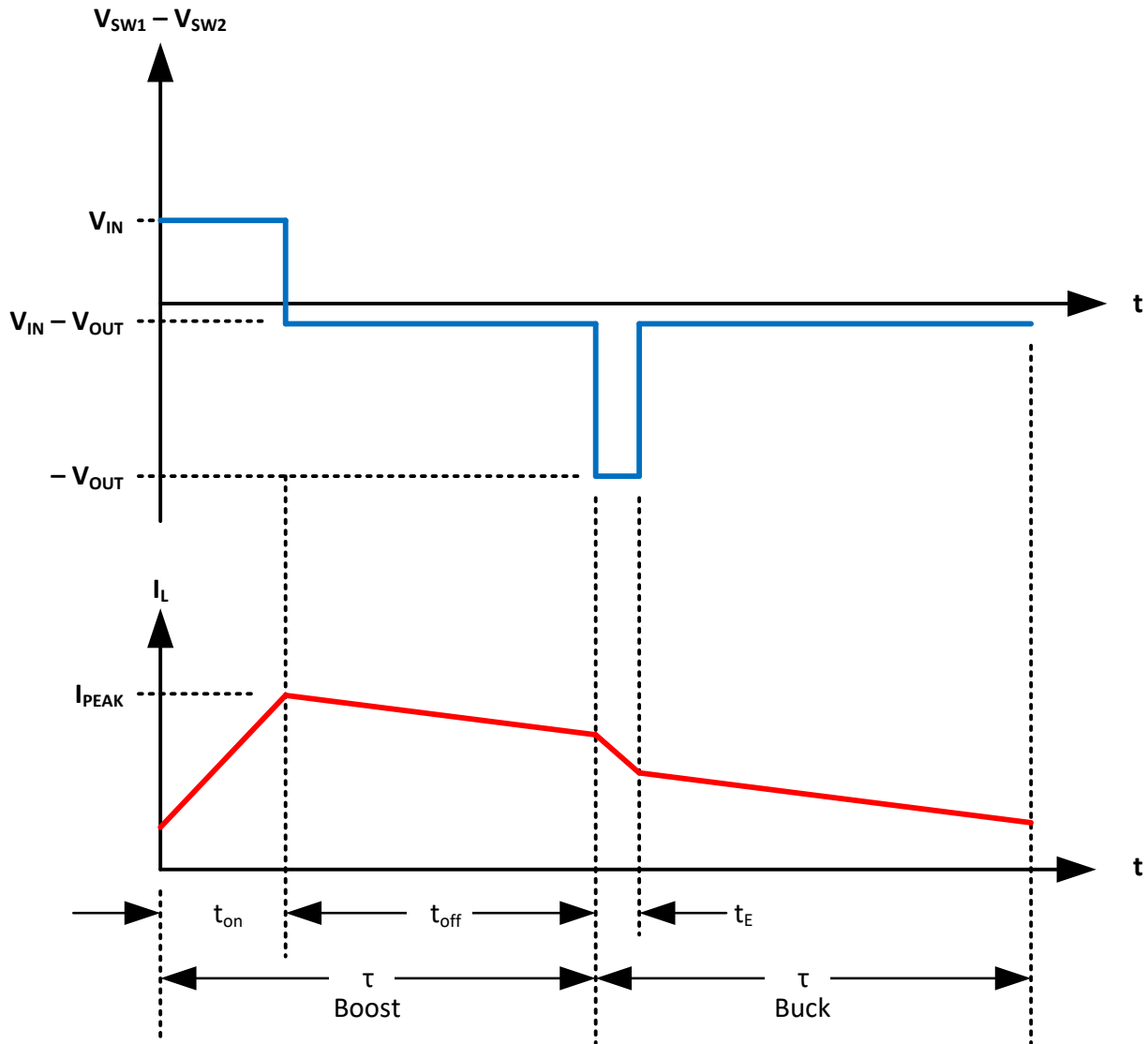


Figure 8-10. Boost Transition

### Boost State

When the input voltage  $V_{IN}$  is significantly less than the output voltage  $V_{OUT}$ , the converter enters the boost region of operation in which it performs an endless series of boost switching cycles **Boost State**. M1 and M5 are constantly on and M2 is constantly off. When the clock signals that a switching cycle has begun, the controller turns on M4 and turns off M3. This switch configuration corresponds to the on-time interval of a traditional boost converter. The voltage difference  $V_{SW1} - V_{SW2}$  across the inductor equals  $V_{IN}$ . The inductor current  $I_L$  ramps up until it reaches a threshold  $I_{PEAK}$  set by the error amplifiers. The controller then turns off M4 and turns on M3. This switch configuration corresponds to the off-time interval of a traditional boost converter. The voltage

difference  $V_{SW1} - V_{SW2}$  now equals  $V_{IN} - V_{OUT}$ , which is negative. The inductor current now ramps down until the converter clock signals that the end of the switching cycle has been reached.

The on-time  $t_{on}$  equals the time interval during which M4 conducts. The off-time  $t_{off}$  equals the time interval during which M3 conducts. Because the converter operates in FCCM, the period  $\tau$  equals the sum of  $t_{on}$  and  $t_{off}$ . During the boost state, the controller regulates power flow by adjusting the boost duty cycle  $D$ , which equals the ratio  $t_{on}/\tau$ .

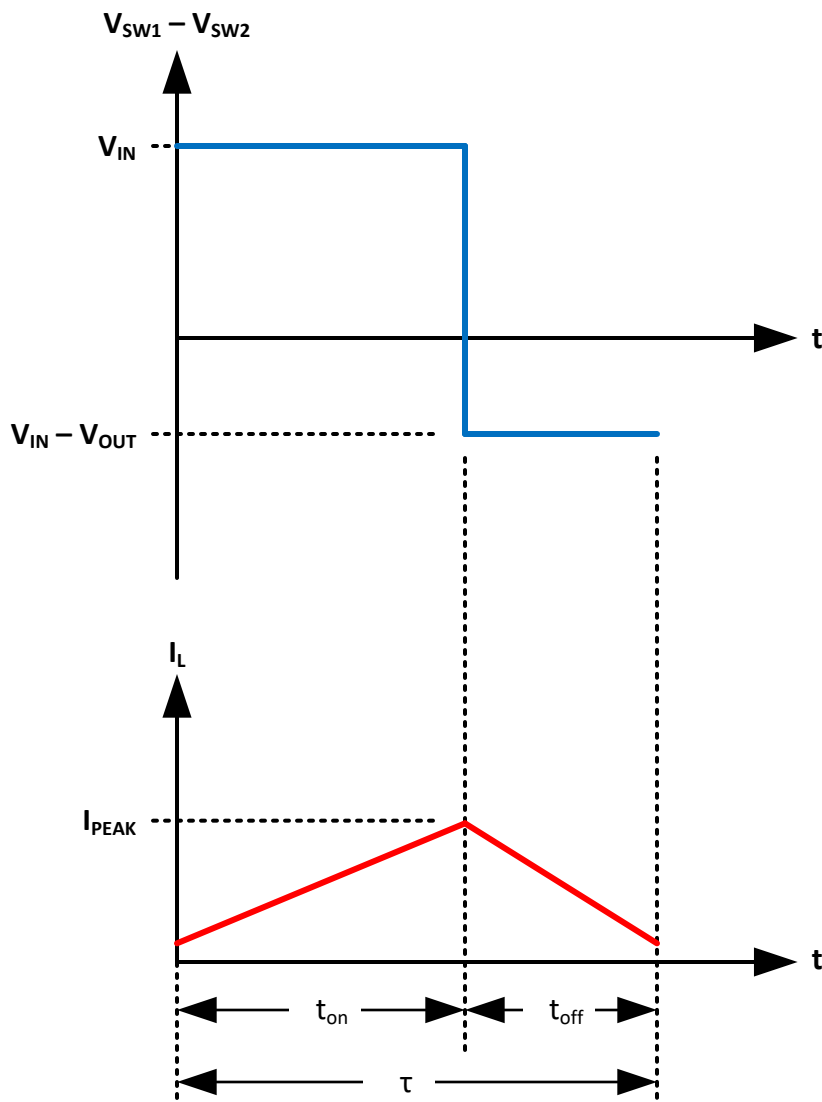
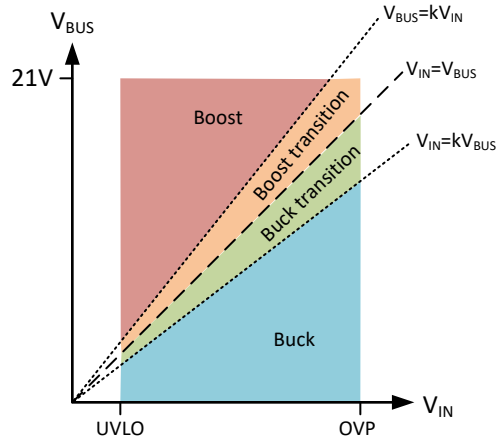


Figure 8-11. Boost State

### Boundaries of the Regions of Operation

**Regions of Operation** graphically depicts the four regions of operation and the boundaries between them. When  $V_{BUS} > kV_{IN}$ , the converter remains in the boost region of operation. The value  $k$  is 1.2. When  $V_{IN} < V_{BUS} < kV_{IN}$ , the converter enters the boost transition region of operation. When  $V_{IN}/k < V_{BUS} < V_{IN}$ , the converter enters the buck transition region of operation. When  $V_{BUS} < V_{IN}/k$ , the converter enters the buck region of operation. The converter ceases operating if  $V_{IN}$  exceeds the OVP threshold, which lies between 18 and 20 V. Similarly, the converter also ceases operating if  $V_{IN}$  drops below either the internal UVLO threshold, which lies between 5 and 5.5 V, or the user programmed EN/UVLO threshold (see [VIN UVLO and ENABLE/UVLO](#), whichever is greater).

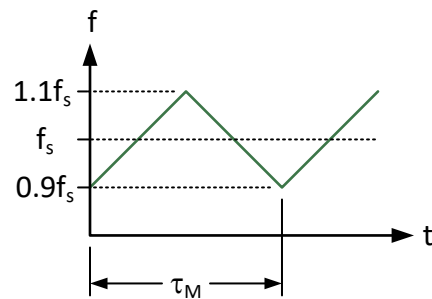


**Figure 8-12. Regions of Operation**

### 8.3.3.2 Switching Frequency, Frequency Dither, Phase-Shift and Synchronization

The PWM oscillator frequency ( $f_{sw}$ ) is programmed by firmware using the application configuration GUI. The switching converter is intended for operation below the AM radio band (520 kHz - 1730 kHz). Three nominal  $f_{sw}$  settings below are available: 300 kHz, 400 kHz and 450 kHz.

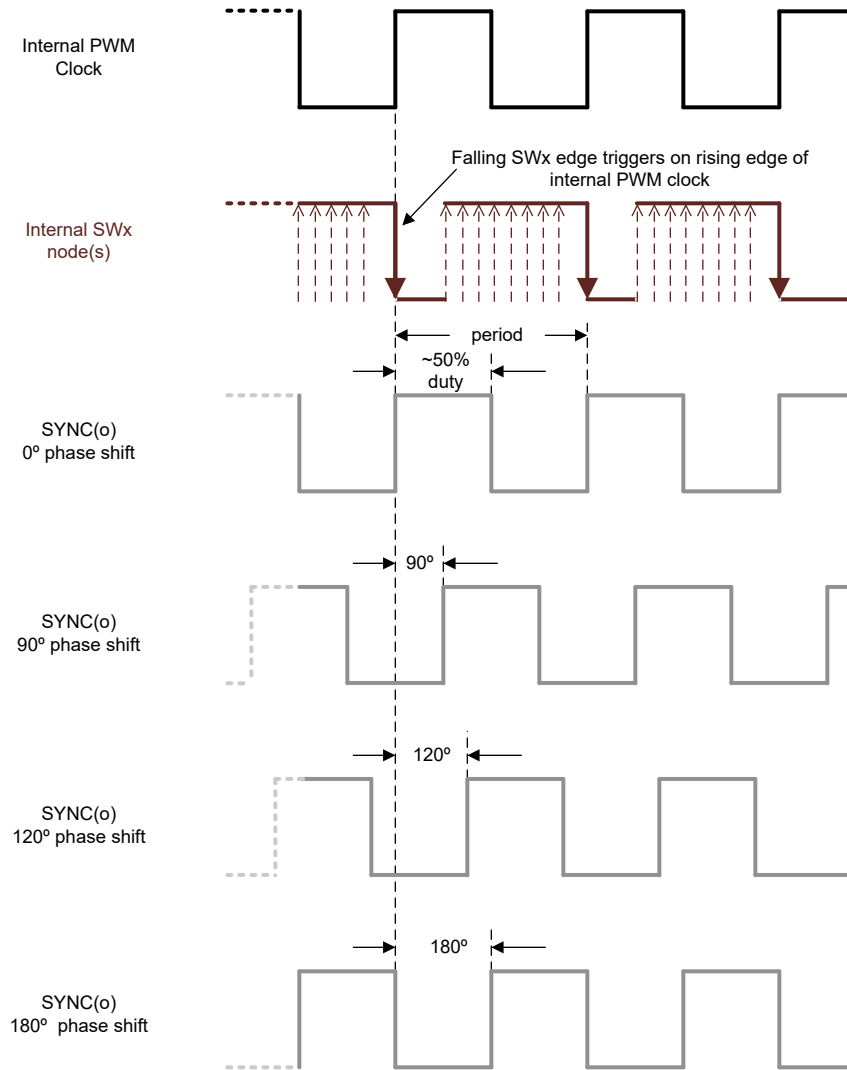
Frequency dithering can be enabled by firmware via the application GUI. When enabled, the nominal oscillator frequency is dithered by  $\pm FS_{SS}$  (approximately  $\pm 10\%$ ) using triangular waveform modulation (see [Dithering using triangular waveform modulation](#)). The dither period  $\tau_M$  is the reciprocal of the dither modulation frequency  $FS_{SS\_MOD}$ . Two firmware selectable dither modulation frequencies  $FS_{SS\_M}$  are available: 10 and 25 kHz. Dithering spreads the spectral peaks generated by switching, thereby reducing the peak harmonic levels and easing EMI filter design.



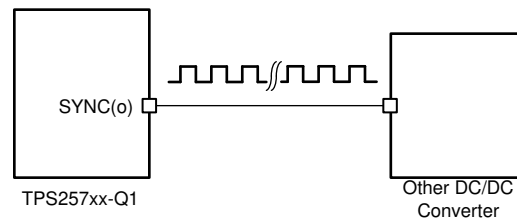
**Figure 8-13. Dithering Using Triangular Waveform Modulation**

Multiple converters can be synchronized using the SYNC pin. This pin can be firmware-configured as either an output SYNC(o) or an input SYNC(i).

- **SYNC(o):** The switching clock is placed on the SYNC(o) pin. This waveform has a duty cycle of approximately 50%. If frequency dithering is configured by firmware, this signal also exhibits dithering. Four phase settings are available by firmware configuration to shift the SYNC(o) output relative to the internal switching clock by  $0^\circ$ ,  $90^\circ$ ,  $120^\circ$ , or  $180^\circ$ . SYNC(o) is used to drive an external DC/DC converter clock with the switching converter clock inside the TPS25762-Q1. When two dc/dc converters operate out of phase, peak input current from the battery is reduced and total input bulk capacitance requirements decrease.



**Figure 8-14. SYNC(o) Phase Shift**



**Figure 8-15. Using SYNC(o) to drive external DC/DC Converter**

- SYNC(i):** The internal clock is synchronized to the pulse train on the SYNC(i) pin. This feature is used to drive the TPS25762-Q1 with an external clock. The period of this clock must meet synchronization requirements in [SYNC\(i\) frequency ranges](#) or the TPS25762-Q1 instead uses its internal switching clock. If an external clock deviates outside of the acceptable frequency range and then returns to within the acceptable frequency range, the TPS25762-Q1 resumes operation from the external clock after counting 8 consecutive clocks meeting the criteria of [Table 8-8](#). When SYNC(i) is configured, frequency dithering is disabled when operating from the internal clock following a failure of the external clock.

**Table 8-8. SYNC(i) Frequency Ranges**

f <sub>sw</sub> Firmware Setting	Allowed SYNC(i) Frequency Range	
	MIN	MAX
300 kHz	250 kHz	353 kHz
400 kHz	334 kHz	470 kHz
450 kHz	376 kHz	530 kHz

### 8.3.3.3 VIN Supply and VIN Over-Voltage Protection

#### V<sub>IN</sub> Supply

The voltage V<sub>IN</sub> at the input supply pin IN, measured with respect to AGND, must meet the following requirements:

- **Overvoltage:** The voltage V<sub>IN</sub> must never exceed an absolute maximum of 40 V, and cannot exceed 36 V under anticipated operating conditions. Automotive applications typically require an external transient suppressor to meet this requirement.
- **Load dump:** When the converter is running and V<sub>IN</sub> exceeds 18 V, the positive slew rate dV<sub>IN</sub>/dt must not exceed 200 V/ms.
- **Double battery:** When the converter is not running, the positive slew rate dV<sub>IN</sub>/dt must not exceed 10 V/μs. The input EMI filter can help mitigate input voltage slew rates.
- **Reverse battery:** The voltage V<sub>IN</sub> must never go below –0.3 V. Automotive applications typically require external reverse voltage blocking circuitry.

The buck-boost switching converter is capable of delivering its full rated output power of 65 W over an input supply range 6.8 V < V<sub>IN</sub> < 18 V. The input voltage can dip down to the UVLO threshold providing that the output power level is appropriately derated.

#### V<sub>IN</sub> Overvoltage Protection Circuitry

The TPS25762-Q1 contains circuitry that protects the power train against load dump and double battery conditions. When V<sub>IN</sub> exceeds approximately 19 V, a comparator determines that an input overvoltage condition has occurred. This comparator sends a signal that shuts the switching converter down. Transistors M1, M2, and M3 in [Buck-Boost Internal Power FETs](#) are turned off, and transistor M4 is turned on. However, current is still flowing through the inductor. Two cases may exist: the current may flow forward (from SW1 to SW2) or in reverse (from SW2 to SW1). Reverse current flow will forward-bias the body diode of M1. The voltage across the inductor then equals the sum of the forward voltage of this diode plus the input voltage, which is sufficient to cause the inductor voltage to rapidly ramp down to zero. Forward current flow will forward-bias the body diode of M2. After the inductor current is released, a small linear regulator biases SW1 to approximately 15 V. When the overvoltage condition is removed, the switching regulator may resume operation.

### 8.3.3.4 Feedback Paths and Error Amplifiers

The TPS25762-Q1 includes not only a programmable voltage feedback path, but also a programmable average current feedback path that can be used to limit the average current provided by the switching converter to the USB cable. The voltage feedback path also includes provision for cable droop compensation. Simplified block diagram of feedback paths and error amplifiers shows a simplified block diagram of the relevant portions of the integrated circuit.

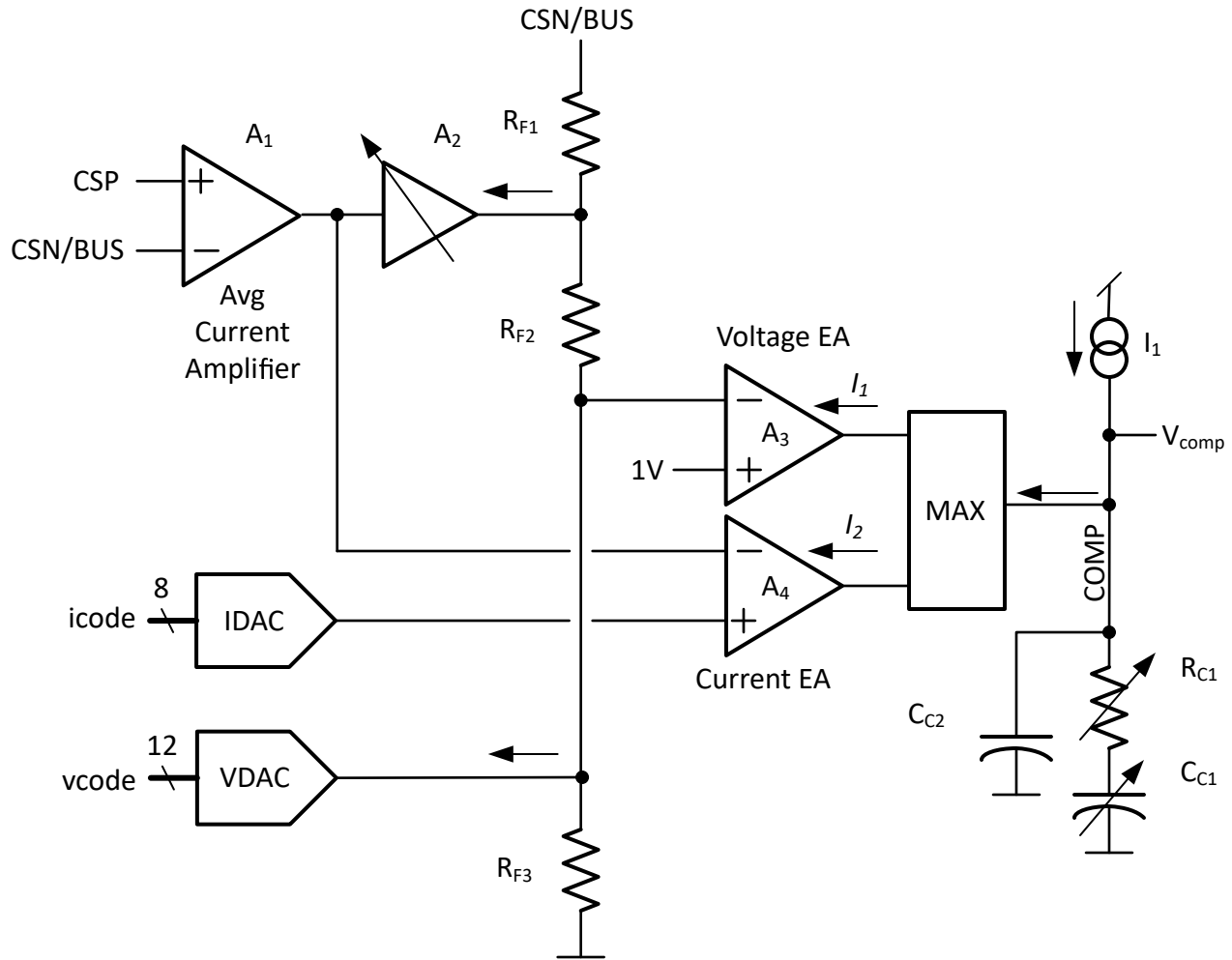


Figure 8-16. Simplified block diagram of feedback paths and error amplifiers.

### 8.3.3.5 Transconductors and Compensation

The TPS25762-Q1 is internally compensated. The overall slope compensation and loop compensation is internally fixed based on inductor and capacitance values shown in [Table 9-1](#).

### 8.3.3.6 Output Voltage DAC, Soft-Start and Cable Droop Compensation

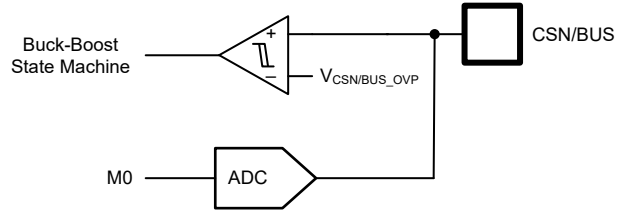
The buck-boost output voltage is regulated at the CSN/VBUS pin. A 12-bit digital-to-analog converter, VDAC, provides  $\pm 20$ -mV step voltage adjustments of  $V_{\text{CSP/VBUS}}$  as commanded by device firmware.

After a successful cable detect event, firmware sets the VDAC to output 5 V as measured on the  $V_{\text{CSN/BUS}}$  output. An internal clock steps up the VDAC codes from an initial 0 V to final 5-V setting producing a monotonic ramp of  $V_{\text{CSN/BUS}}$  to 5 V at  $t_{\text{SS}}$ .

In some applications, the USB-PD controller may be located 1 m, or more, from the USB receptacle. When configured and enabled by firmware, cable droop compensation increases the  $V_{\text{CSP/VBUS}}$  linearly with increasing load current independent of the VDAC setting. Four selectable  $V_{\text{OUT\_CDC}}$  ranges are available. 500 mV is the maximum supported cable droop voltage and it is disabled by default during USB-PD PPS contracts.

### 8.3.3.7 $V_{\text{BUS}}$ Overvoltage Protection

A fixed threshold overvoltage comparator monitors the CSN/BUS pin for overvoltage conditions. When the  $V_{\text{CSN/BUS\_OVP\_R}}$  threshold is exceeded, output OV protection circuitry turns off the internal MOSFETs. Switching resumes when  $V_{\text{CSN/BUS}}$  decreases below  $V_{\text{CSN/BUS\_OVP\_F}}$ .



**Figure 8-17.  $V_{BUS}$  OVP and UVP**

### 8.3.3.8 $V_{BUS}$ Undervoltage Protection

PA\_VBUS undervoltage conditions are monitored by the internal ADC. In accordance with USB Power Delivery specifications, the TPS25762-Q1 firmware configures the threshold based on USB PD contract with the attached sink device.

### 8.3.3.9 Current Sense Resistor ( $R_{SNS}$ ) and Current Limit Operation

The CSP and CSN/BUS pins are the positive and negative inputs to the average current sense amplifier (CSA). The TPS25762-Q1 devices sense port A load current across sense resistor,  $R_{SNS}$ , located between the CSP and CSN/BUS pins. A 10-m $\Omega$ , 1%, power resistor provides a 0 - 50-mV sense voltage over the range  $0 \leq I_{OUT} \leq 5$  A.

A seven bit digital-to-analog converter, IDAC, provides  $\pm 50$ -mA step current limit adjustments and is automatically programmed by device firmware.

### 8.3.3.10 Buck-Boost Peak Current Limits

The buck and boost peak current limits are adjustable by firmware using the application configuration GUI. Refer to the BUCK-BOOST PEAK CURRENT LIMITS in Buck-Boost Regulator of the *Electrical Characteristics* tables for selectable values.

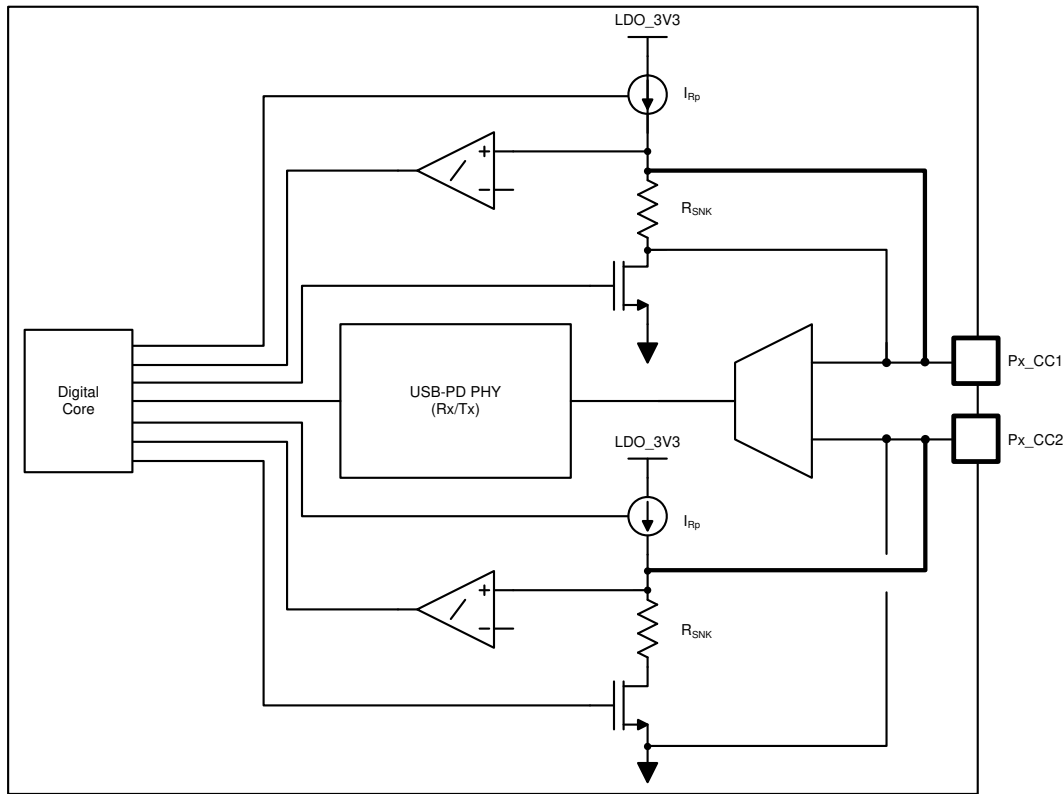
In most applications it is desirable to limit input current to the automotive USB module to protect module components, connectors and wiring from over-current conditions. The worst case input current condition occurs when  $V_{IN}$  is minimum and  $V_{CSN/BUS}$  is maximum (21 V) while supplying maximum 3.25 A output current. When  $V_{IN} < V_{BUS}$ , the internal DC/DC converter is operating in boost mode. Refer to the Buck Calculation Results ( $L=4.7$  uH). I BUS = 3 A tables in the *Inductor Currents* section to estimate the peak current versus recommended inductor value for the application.

The buck peak current limit setting selection can be just lower than the boost peak current limit. Set as close to the boost peak current limit as selections allow to prevent the possibility of limit cycling between the two peak current limits under extreme transients.  $I_{PEAK(BUCK)} \cong I_{PEAK(BOOST)}$ .

When selecting an inductor, it is important to select one with an appropriate saturation current rating,  $I_{L(SAT)}$ . The inductor  $I_{L(SAT)}$  rating must be larger than the maximum (MAX)  $I_{PEAK(BOOST)}$  limit from the *Electrical Characteristics* tables to avoid excessive current flow in the TPS25762-Q1 or the inductor.

## 8.3.4 USB-PD Physical Layer

Figure 8-18 shows the USB PD physical layer block surrounded by a simplified version of the analog plug and orientation detection block. This block applies to Port A.

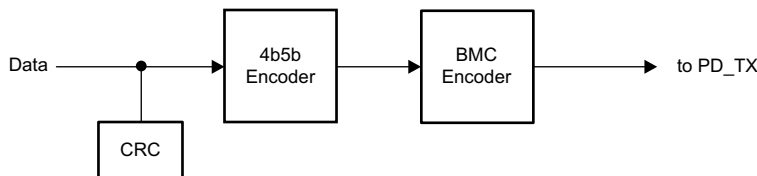


**Figure 8-18. USB-PD Physical Layer and Simplified Plug and Orientation Detection Circuitry**

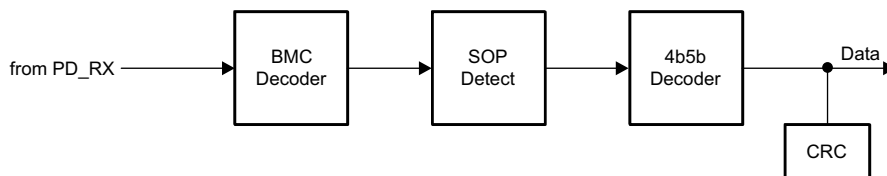
USB-PD messages are transmitted in a USB Type-C system using a BMC (Biphase Mark Coding) signaling. The BMC signal is output on the same pin (Px\_CC1 or Px\_CC2) that is DC biased due to the Rp (or Rd) cable attach mechanism discussed in the [USB-PD BMC Transmitter](#) section.

**8.3.4.1 USB-PD Encoding and Signaling**

Figure 8-19 illustrates the high-level block diagram of the baseband USB-PD transmitter. Figure 8-20 illustrates the high-level block diagram of the baseband USB-PD receiver.



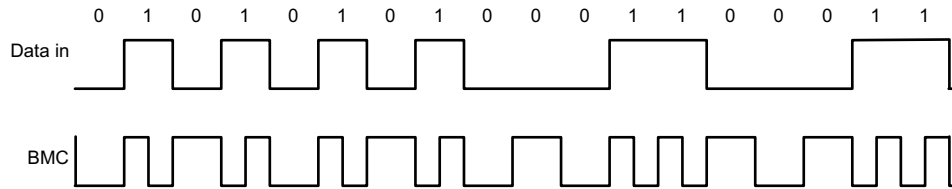
**Figure 8-19. USB-PD Baseband Transmitter Block Diagram**



**Figure 8-20. USB-PD Baseband Receiver Block Diagram**

### 8.3.4.2 USB-PD Bi-Phase Marked Coding

The USB-PD physical layer implemented in the TPS25762-Q1 is compliant to the [USB-PD Specifications](#). The encoding scheme used for the baseband PD signal is a version of Manchester coding called Biphasic Mark Coding (BMC). In this code, there is a transition at the start of every bit time and there is a second transition in the middle of the bit cell when a 1 is transmitted. This coding scheme is nearly DC balanced with limited disparity (limited to 1/2 bit over an arbitrary packet, so a very low DC level). [Figure 8-21](#) illustrates Biphasic Mark Coding.



**Figure 8-21. Biphasic Mark Coding Example**

The USB PD baseband signal is driven onto the Px\_CC1 or Px\_CC2 pin with a tri-state driver. The tri-state driver controls slew rate to limit coupling to D+/D– and to other signal lines in the Type-C fully featured cables. When sending the USB-PD preamble, the transmitter starts by transmitting a low level. The receiver at the other end tolerates the loss of the first edge. The transmitter terminates the final bit by an edge to ensure the receiver clocks the final bit of EOP.

### 8.3.4.3 USB-PD Transmit (TX) and Receive (Rx) Masks

The USB-PD driver meets the defined USB-PD BMC TX masks. Since a BMC coded “1” contains a signal edge at the beginning and middle of the UI, and the BMC coded “0” contains only an edge at the beginning, the masks are different for each. The USB-PD receiver meets the defined USB-PD BMC Rx masks. The boundaries of the Rx outer mask are specified to accommodate a change in signal amplitude due to the ground offset through the cable. The Rx masks are therefore larger than the boundaries of the TX outer mask. Similarly, the boundaries of the Rx inner mask are smaller than the boundaries of the TX inner mask. Triangular time masks are superimposed on the TX outer masks and defined at the signal transitions to require a minimum edge rate that has minimal impact on adjacent higher speed lanes. The TX inner mask enforces the maximum limits on the rise and fall times. Refer to the [USB-PD Specifications](#) for more details.

### 8.3.4.4 USB-PD BMC Transmitter

The TPS25762-Q1 transmits and receives USB-PD data over one of the Px\_CCy pins for a given CC pin pair (one pair per USB Type-C port). The Px\_CCy pins are also used to determine the cable orientation (see the [Cable Plug and Orientation Detection](#) section) and maintain cable/device attach detection. Thus, a DC bias exists on the Px\_CCy pins. The transmitter driver overdrives the Px\_CCy DC bias while transmitting, but returns to a Hi-Z state allowing the DC voltage to return to the Px\_CCy pin when not transmitting. While either Px\_CC1 or Px\_CC2 may be used for transmitting and receiving, during a given connection only the one that mates with the CC pin of the plug is used; so there is no dynamic switching between Px\_CC1 and Px\_CC2. [Figure 8-22](#) shows the USB-PD BMC TX and RX driver block diagram.

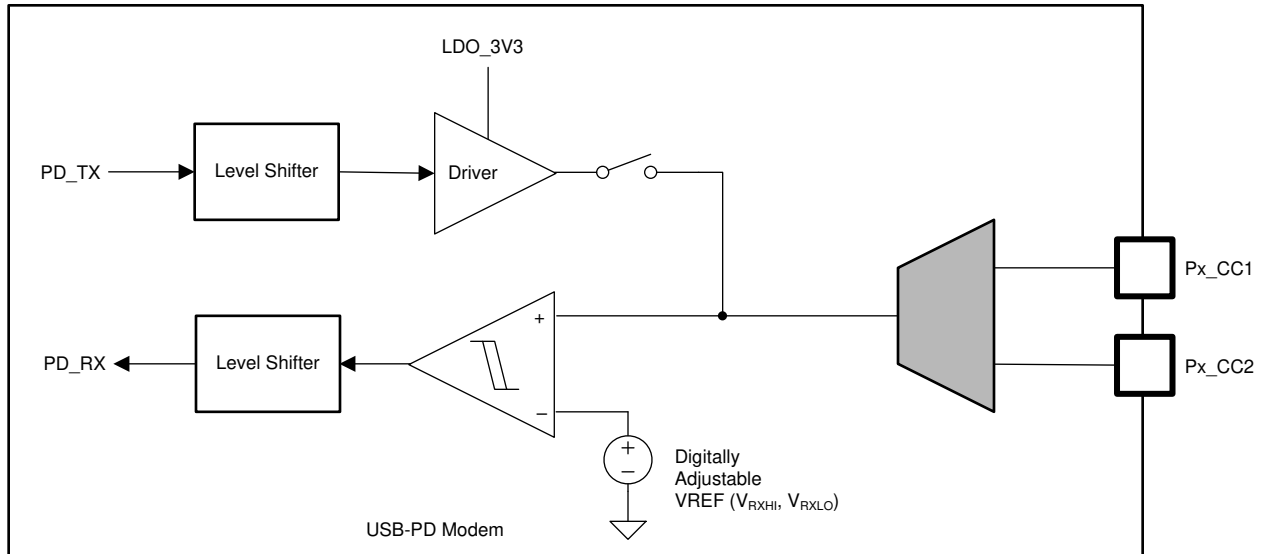


Figure 8-22. USB-PD BMC TX/Rx Block Diagram

Figure 8-23 shows the transmission of the BMC data on top of the DC bias. Note, The DC bias can be anywhere between the minimum threshold for detecting a UFP attach and the maximum threshold for detecting a Sink attach to a Source resulting in a DC bias that can be above or below the  $V_{OH}$  of the transmitter driver.

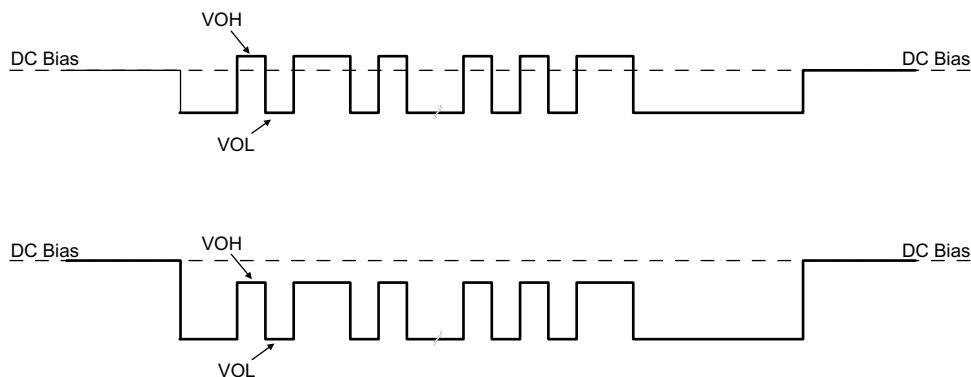


Figure 8-23. TX Driver Transmission with DC Bias

The transmitter drives a digital signal onto the Px\_CCy lines. The signal peak,  $V_{TXHI}$ , is set to meet the TX masks defined in the [USB-PD Specifications](#). Note that the TX mask is measured at the far-end of the cable.

When driving the line, the transmitter driver has an output impedance of  $Z_{DRIVER}$ .  $Z_{DRIVER}$  is determined by the driver resistance and the shunt capacitance of the source and is frequency dependent.  $Z_{DRIVER}$  impacts the noise ingress in the cable.

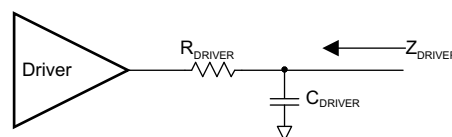


Figure 8-24. ZDRIVER Circuit

#### 8.3.4.5 USB-PD BMC Receiver

The receiver block of the TPS25762-Q1 receives a signal that falls within the allowed Rx masks defined in the USB PD specification. The receive thresholds and hysteresis come from this mask.

Figure 8-25 shows an example of a multi-drop USB-PD connection (only the CC wire). This connection has the typical Sink (device) to Source (host) connection, but also includes cable USB-PD Tx/Rx blocks. Only one system can be transmitting at a time. All other systems are Hi-Z ( $Z_{BMCRX}$ ). The *USB-PD Specification* also specifies the capacitance that can exist on the wire as well as a typical DC bias setting circuit for attach detection.

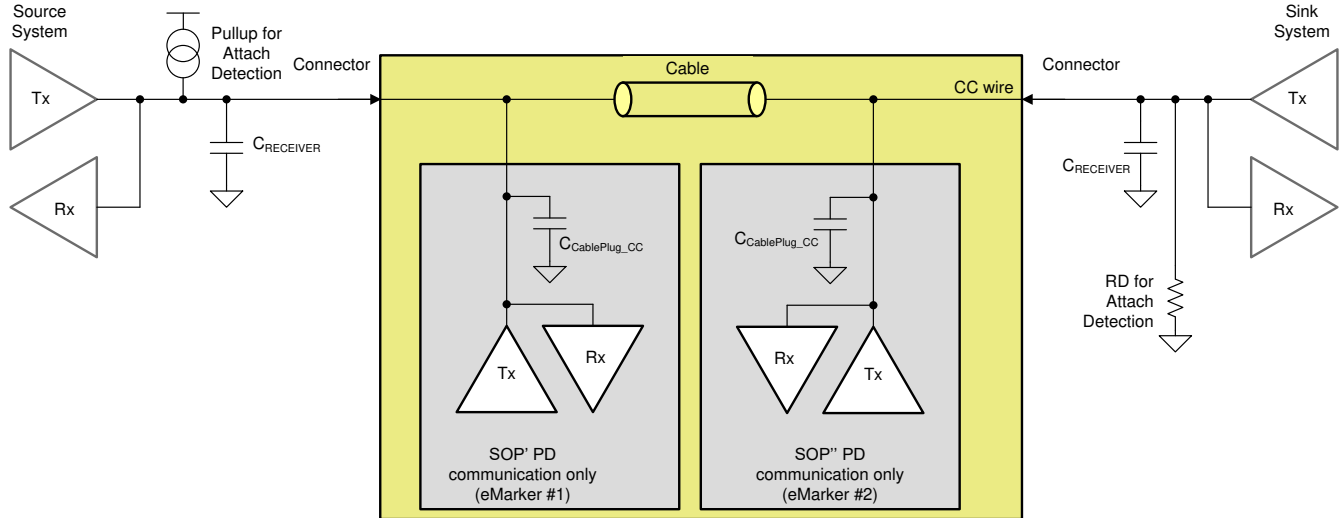


Figure 8-25. Example USB-PD Multi-Drop Configuration

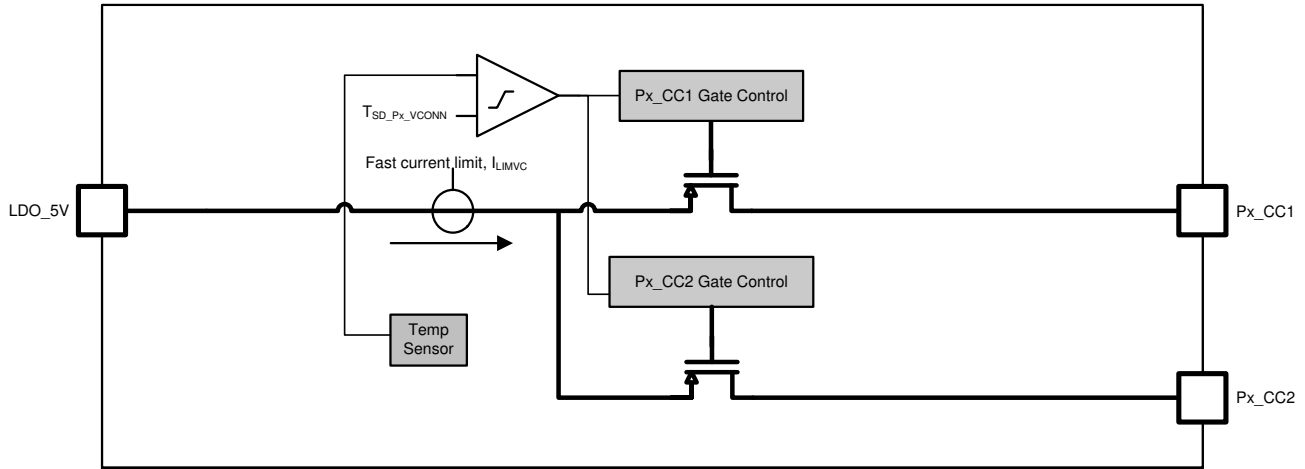
#### 8.3.4.6 Squelch Receiver

The TPS25762-Q1 has a squelch receiver to monitor for the bus idle condition as defined by the USB PD specification. The squelch receiver output reflects the state of the CC pin regardless of the source of the transmission.

#### 8.3.5 VCONN

Internal VCONN sourcing power paths are firmware configurable. Using only the internal LDO\_5V supply, PortA is able to draw 20 mA continuously. If an external 5-V regulator is connected to the LDO\_5V pin and the application GUI settings are enabled, PortA is able to draw 200 mA continuously. When disabled, blocking FETs in the PortA VCONN paths protect the LDO\_5V rail from high-voltage and reverse current.

When VCONN power is enabled and provided, the internal VCONN power switches have a current limit of  $I_{LIMVC}$ . If the VCONN load current exceeds  $I_{LIMVC}$ , the current clamping circuit activates within  $t_{IOS\_PP\_CABLE}$  and the switch behaves as a constant current source. Reverse current blocking is disabled when current is flowing to Px\_CC1 or Px\_CC2.



**Figure 8-26. VCONN Power Switches**

When operating in current limit, the VCONN FET temperature rises. Local temperature sensors disable the Px\_VCONN path in current limit when  $T_{\text{sensor}} > T_{\text{SD\_Px\_VCONN}}$  within  $t_{\text{PP\_CABLE\_off}}$ . The application firmware enters USB Type-C Error Recovery on the affected port.

LDO\_5V must remain above its under voltage lock out threshold ( $V_{\text{LDO\_5V(UVLO\_F)}}$ ) for Px\_VCONN operation. If the  $V_{\text{LDO\_5V(UVLO\_F)}}$  threshold is reached, Px\_VCONN paths are automatically disabled within  $t_{\text{PP\_CABLE\_off}}$ .

### 8.3.6 Cable Plug and Orientation Detection

Figure 8-27 shows the plug and orientation detection block at each Px\_CCy pin (PA\_CC1, PA\_CC2, PB\_CC1, PB\_CC2). Each CC pin has identical detection circuitry.

When the port is operating as a Type-C source, the  $V_{\text{REFx}}$  nodes are multiplexed to the  $V_{\text{SRC}}$  thresholds corresponding to the advertised Type-C source capability current,  $I_{\text{Rp\_}}$ .

When the port is operating as a Type-C sink, the  $V_{\text{REFx}}$  nodes are multiplexed to the  $V_{\text{SNK}}$  thresholds corresponding to sink detection.

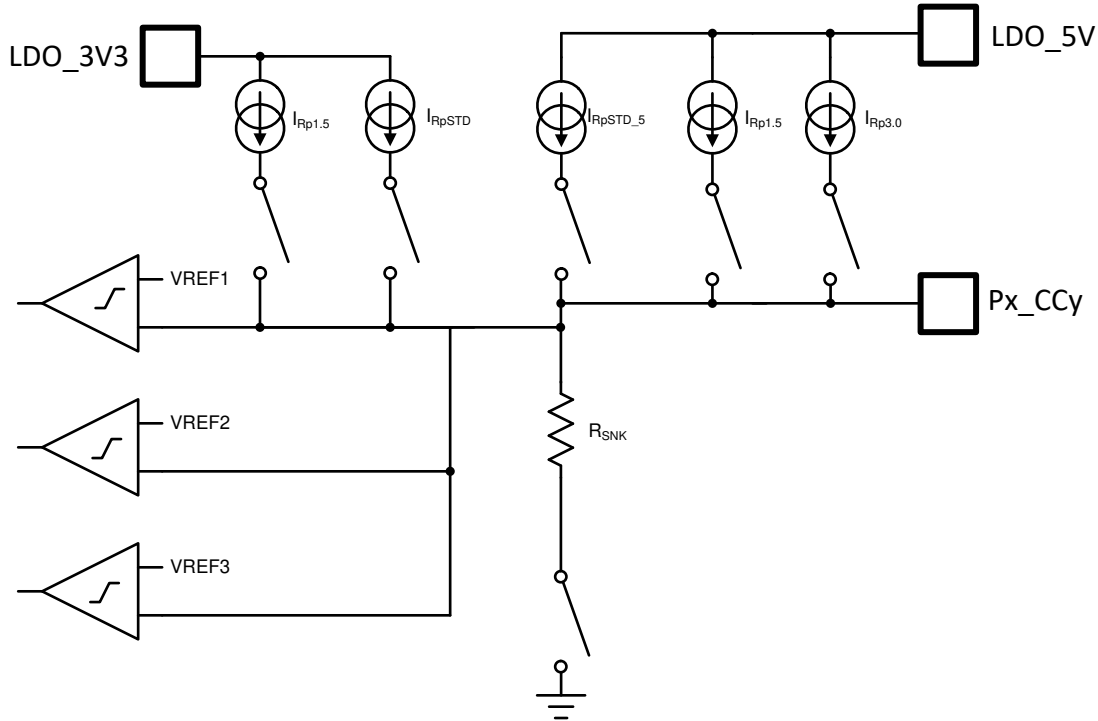


Figure 8-27. Plug and Orientation Detection Block

### 8.3.6.1 Configured as a Source

When Port A is configured as a Source, the device detects when a cable or a Sink is attached using the Px\_CC1 and Px\_CC2 pins. When in a disconnected state, the device monitors the voltages on these pins to determine what, if anything, is connected. See [USB Type-C Specification](#) for more information.

Table 8-9 shows the Cable Detect States for a Source.

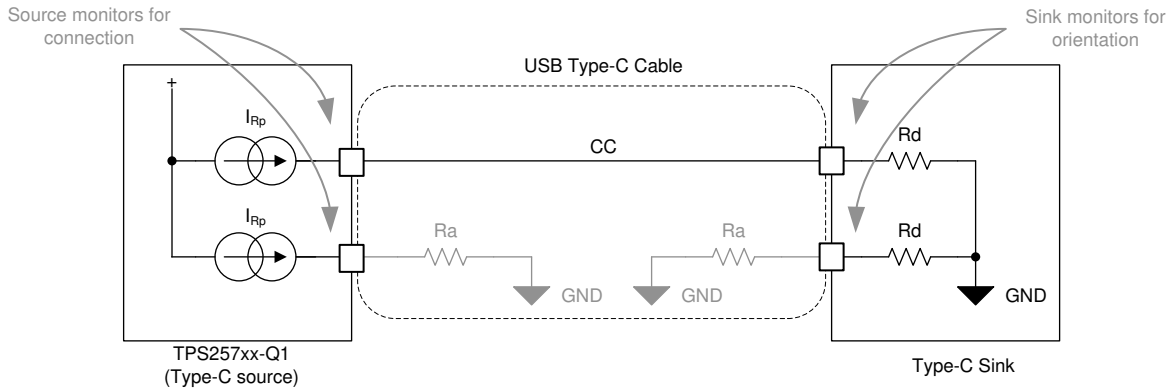
Table 8-9. Cable Detect States for a Source

Px_CC1	Px_CC2	CONNECTION STATE	RESULTING ACTION
Open	Open	Nothing attached	Continue monitoring both Px_Cc2 pins for attach. Power is not applied to Px_VBUS or VCONN.
Rd	Open	Sink attached	Monitor Px_CC1 for detach. Power is applied to Px_VBUS but not to VCONN (Px_CC2).
Open	Rd	Sink attached	Monitor Px_CC2 for detach. Power is applied to Px_VBUS but not to VCONN (Px_CC1).
Ra	Open	Powered Cable-No UFP attached	Monitor Px_CC2 for a Sink attach and Px_CC1 for cable detach. Power is not applied to Px_VBUS or VCONN (Px_CC1).
Open	Ra	Powered Cable-No UFP attached	Monitor Px_CC1 for a Sink attach and Px_CC2 for cable detach. Power is not applied to Px_VBUS or VCONN (Px_CC2).
Ra	Rd	Powered Cable-UFP Attached	Provide power on Px_VBUS and VCONN (Px_CC1) then monitor Px_CC2 for a Sink detach. Px_CC1 is not monitored for a detach.
Rd	Ra	Powered Cable-UFP attached	Provide power on Px_VBUS and VCONN (Px_CC2) then monitor Px_CC1 for a Sink detach. Px_CC2 is not monitored for a detach.

When a port is configured as a Source, a current  $I_{Rp1.5A}$ , is driven out of each Px\_Cc2 pin and each pin is monitored for different states. When a Sink is attached to the port a pull-down resistance of  $R_d$  to GND exists. The current  $I_{Rp1.5A}$  is then forced across the resistance  $R_d$  generating a voltage at the Px\_Cc2 pin. The device applies the configured  $I_{Rp1.5A}$  until the buck-boost regulator is enabled and operating at 5 V, at which time application firmware may remain at  $I_{Rp1.5A}$  or change to  $I_{Rp3.0A}$ .

When the P<sub>x</sub>\_CC<sub>y</sub> pin is connected to an electronically marked cable VCONN input, the pull-down resistance is different (R<sub>a</sub>). In this case the voltage on the P<sub>x</sub>\_CC<sub>y</sub> pin pulls below V<sub>RDstd</sub> and the system recognizes the electronically marked cable.

The V<sub>Dstd1.5</sub> or V<sub>D3.0</sub> threshold is monitored to detect a disconnection depending upon which R<sub>p</sub> current source is active. When a connection has been recognized and the voltage on P<sub>x</sub>\_CC<sub>y</sub> subsequently rises above the disconnect threshold for t<sub>CC</sub>, the system registers a disconnection.



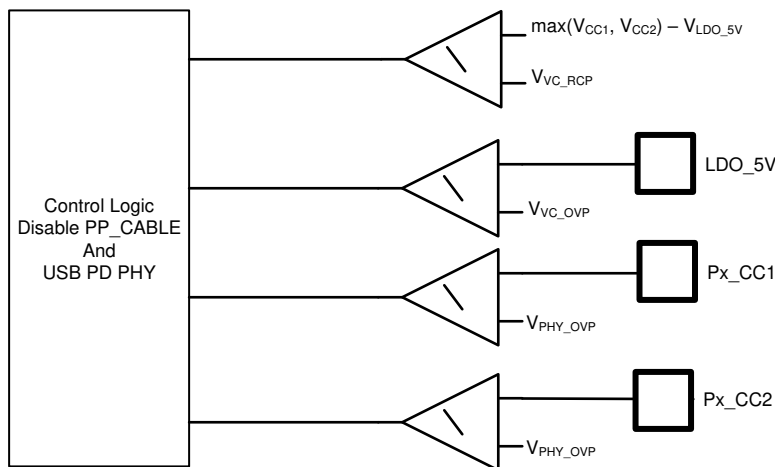
**Figure 8-28. Type-C Cable**

**8.3.6.2 Configured as a Sink**

When the TPS25762-Q1 port is configured as a Sink, such as in Firmware Update Mode with TVSP Index 8, the device presents a pull-down resistance R<sub>SNK</sub> on each PA\_CC<sub>y</sub> pin and waits for a Source to attach and pull-up the voltage on the pin. The Source pulls-up the PA\_CC<sub>y</sub> pin by applying either a resistance or a current. The Sink detects an attachment by the presence of VBUS. The Sink determines the advertised current from the Source by the pull-up applied to the PA\_CC<sub>y</sub> pin.

**8.3.6.3 Overvoltage Protection (P<sub>x</sub>\_CC1, P<sub>x</sub>\_CC2)**

Comparators on the P<sub>x</sub>\_CC<sub>y</sub> pins detect when the voltage on CC1 or CC2 is too high, or there is reverse current into the LDO\_5V output. During an overvoltage event, VCONN is disabled within tPP\_CABLE\_FSD and the associated USB PD transmitter is disabled.



**Figure 8-29. Over-voltage and Reverse Current Protection**

### 8.3.7 ADC

The ADC is shown in [Figure 8-30](#). The ADC is an 8-bit successive approximation ADC. The input to the ADC is an analog input mux that supports multiple inputs from various voltages and currents in the device. The output from the ADC is available to be read and used by application firmware.

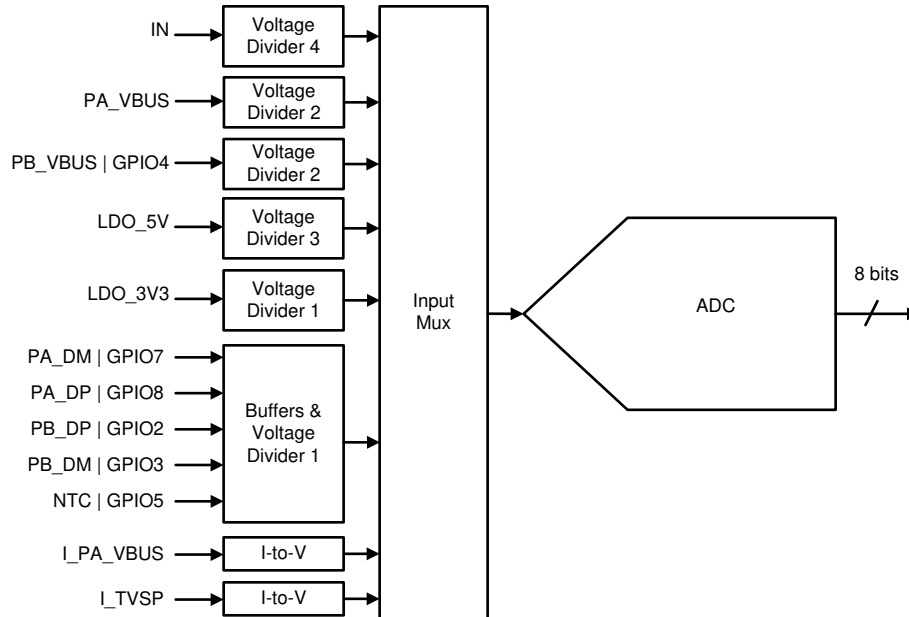


Figure 8-30. SAR ADC

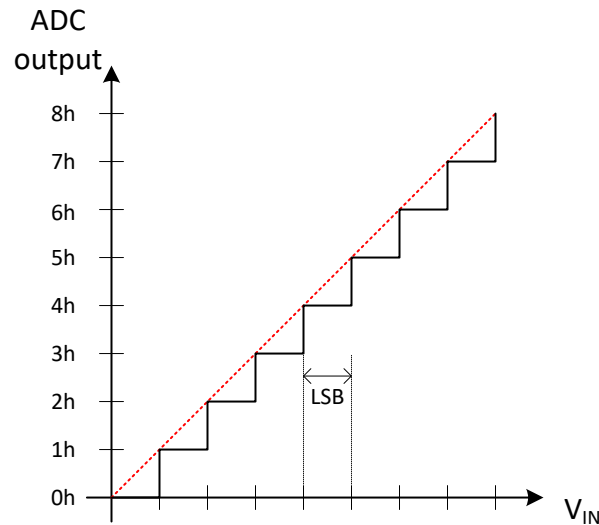


Figure 8-31. ADC Conversion

#### 8.3.7.1 ADC Divider Ratios

The ADC voltage inputs are each divided down to the full-scale input of 1.2 V. The ADC current sensing elements are not divided.

[Table 8-10](#) shows the divider ratios for each ADC input. The application firmware may select any group of channels to be auto-sequenced in the round robin automatic readout mode.

**Table 8-10. ADC Inputs**

CHANNEL	SIGNAL	TYPE	DIVIDER RATIO	BUFFERED
0	I_TVSP	Current	n/a	No
1	IN	Voltage	17	No
2	LDO_3V3	Voltage	3	No
3	PA_VBUS	Voltage	21	No
4	GPIO4   PB_VBUS	Voltage	21	No
5	I_PA_VBUS	Current	n/a	No
6	GPIO2   PB_DP	Voltage	3	Yes
7	GPIO3   PB_DM	Voltage	3	Yes
8	GPIO5   NTC	Voltage	3	Yes
9	GPIO7   PA_DM	Voltage	3	Yes
10	GPIO8   PA_DP	Voltage	3	Yes
11	LDO_5V	Voltage	5	No

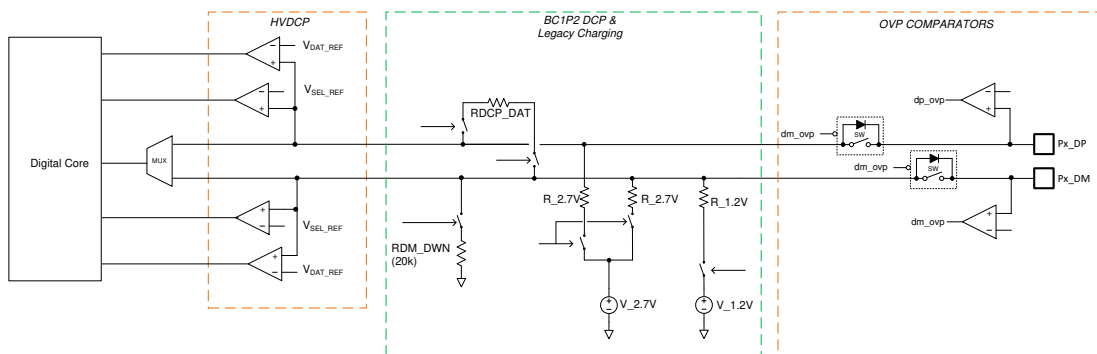
**8.3.8 BC 1.2, Legacy and Fast Charging Modes (Px\_DP, Px\_DM)**

BC 1.2 downstream port charger emulation is application GUI configurable. The following charging modes can be enabled or disabled:

- DCP (Dedicated Charging Port) Shorted Mode
- Divider-3 Mode
- 1.2-V Mode
- HVDCP (High Voltage Dedicated Charging Port) Mode

The following table shows voltage sources, resistors and comparator hardware used in each mode. Symbol "X" represents that the corresponding module is implemented.

Application	2.7-V SRC	1.2-V SRC	R <sub>DCP_DAT</sub>	R <sub>DM_DWN</sub> (20 kΩ)	V <sub>DAT_REF</sub>	V <sub>SEL_REF</sub>
DCP			X			
Divider-3	X					
1.2 V		X	X			
HVDCP				X	X	X



**Figure 8-32. BC1P2 Functional Diagram**

**8.3.9 USB2.0 Low-Speed Endpoint**

The USB low-speed Endpoint is a USB 2.0 low-speed (1.5 Mbps) interface used to support HID class based accesses. The TPS25762-Q1 supports control of endpoint EP0. This endpoint enumerates to a USB 2.0 host

during firmware update mode. Firmware update mode is entered with when the device is powered on with an  $R_{TVSP}$  corresponding to TVSP Index 8.

Figure 8-33 shows the USB Endpoint physical layer. The physical layer consists of the analog transceiver, the Serial Interface Engine, and the Endpoint FIFOs and supports low-speed USB operation.

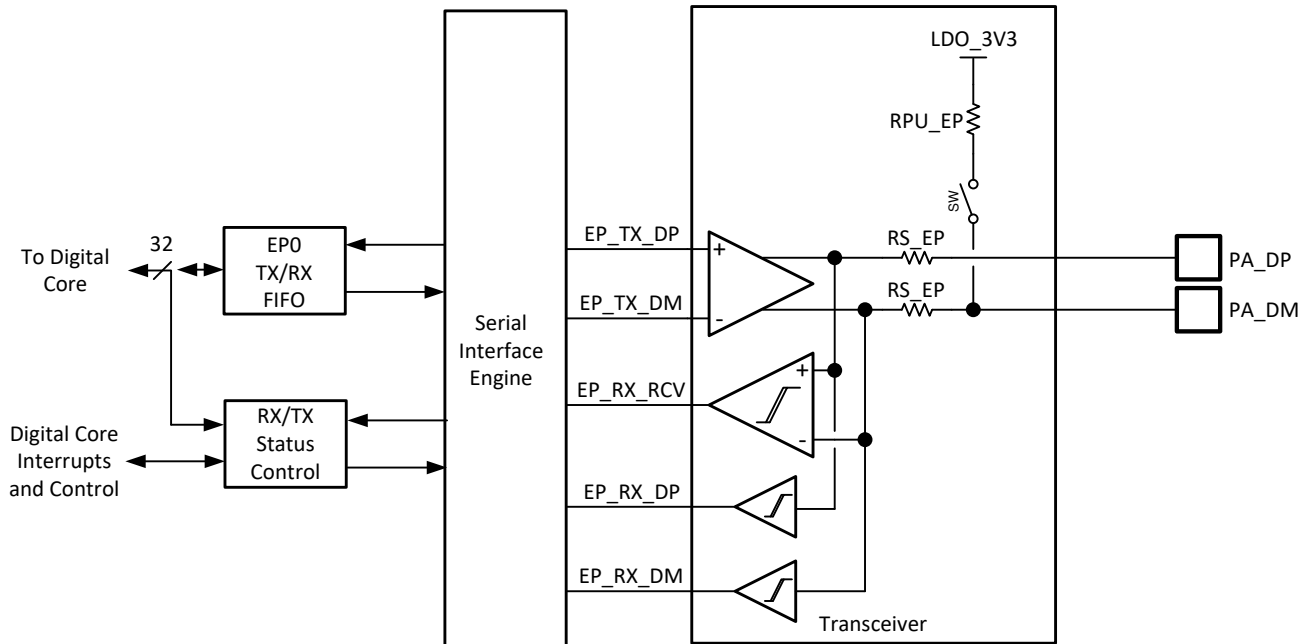


Figure 8-33. USB Endpoint PHY

The transceiver is made up of a fully differential output driver, a differential to single-ended receive buffer and two single-ended receive buffers on the D+/D– independently. The output driver drives the D+/D– through a source resistance  $RS_{EP}$ .  $RPU_{EP}$  is disconnected during transmit mode of the transceiver.

When the endpoint is in receive mode, the resistance  $RPU_{EP}$  is connected to the PA\_DM pin. The  $RPU_{EP}$  resistance advertises low speed mode only.

### 8.3.10 Digital Interfaces

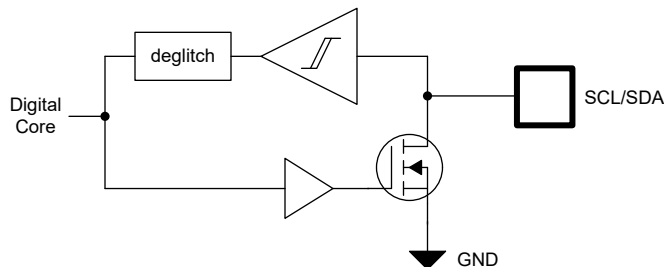
The TPS25762-Q1 contains one I<sup>2</sup>C controller which used for communicating with I<sup>2</sup>C target devices. Depending upon application GUI firmware configuration, an I<sup>2</sup>C target and GPIOs may be available.

#### 8.3.10.1 General GPIO

The application configuration GUI manages the multi-function pins which contain General Purpose Input/Output functionality. Each buffer is configurable to be a push-pull output or open drain output. When configured as an input, the signal can be a de-glitched digital input or an analog input to the ADC (only designated pins). The push-pull output is a simple CMOS totem-pole structure. Independent pull-up and pull-down enables can be configured using the application GUI. When interfacing with non 3.3-V I/O devices the output buffer can be configured as an open drain output and an external pull-up resistor attached to the GPIO pin.

#### 8.3.10.2 I<sup>2</sup>C Buffer

The TPS25762-Q1 features two I<sup>2</sup>C interfaces that each use an I<sup>2</sup>C I/O driver like the one shown in Figure 8-34. This I/O consists of an open-drain output and an input comparator with de-glitching.

Figure 8-34. I<sup>2</sup>C Driver

### 8.3.11 I<sup>2</sup>C Interface

The TPS25762-Q1 has two I<sup>2</sup>C ports. I<sup>2</sup>C1 is a controller interface. I<sup>2</sup>C2 is a target interface.

I<sup>2</sup>C1 is used to read from or write to external target devices. During boot I<sup>2</sup>C1 is configured to read firmware patch and application configuration data from an external EEPROM with target address 0x50.

Depending upon application configuration, the TPS25762-Q1 may expose target port, I<sup>2</sup>C2, using multi-function pins: GPIO2 (I<sup>2</sup>C\_SCL2), GPIO3 (I<sup>2</sup>C\_SDA2). When the TPS257xx-Q1 is used in systems with a HUB or MCU, the I<sup>2</sup>C2 port can provide connection status and telemetry information as well as transfer firmware updates from the HUB or MCU to an EEPROM connected on I<sup>2</sup>C1.

$\overline{\text{IRQ}}$  functionality depends upon firmware application configuration.  $\overline{\text{IRQ}}$  is not always available on both I<sup>2</sup>C1 and I<sup>2</sup>C2 simultaneously. the IRQ is available as follows:

- Multi-function pin GPIO9:  $\overline{\text{IRQ}}1(i)$ ,  $\overline{\text{IRQ}}1(o)$ ,  $\overline{\text{IRQ}}2(o)$
- Multi-function pin GPIO1:  $\overline{\text{IRQ}}2(o)$

Where (i) = operates as an input, and (o) = operates as output.

In HUB applications where I<sup>2</sup>C control is not used, GPIO9 can be configured as a simple  $\overline{\text{FAULT}}$  pin reporting port over-current conditions as required by the USB 2.0 specifications.

Table 8-11. I<sup>2</sup>C Summary

I <sup>2</sup> C Bus	Type	Typical Usage	Max Bus Frequency
I2C1c	Controller	Connect to I <sup>2</sup> C EEPROM, USB Type-C mux, I2C temperature sensor, I2C GPIO expander, or other I2C target. Use LDO_5V or LDO_3V3 pin as the pull-up voltage. Multi-controller configuration is not supported.	1 MHz (Fast Mode Plus)
I2C2t	Target	Connect to I <sup>2</sup> C capable USB HUB, MCU or automotive processor.	1 MHz (Fast Mode Plus)

#### 8.3.11.1 I<sup>2</sup>C Interface Description

The I<sup>2</sup>C1 and I<sup>2</sup>C2 ports support Standard, Fast Mode, and Fast Mode Plus I<sup>2</sup>C interfaces. The bidirectional I<sup>2</sup>C bus consists of the serial clock (SCL) and serial data (SDA) lines. Both lines must be connected to a supply through a pull-up resistor. Data transfer may be initiated only when the bus is not busy.

A controller sending a Start condition, a high-to-low transition on the SDA input/output, while the SCL input is high initiates I<sup>2</sup>C communication. After the Start condition, the device address byte is sent, most significant bit (MSB) first, including the data direction bit (R/W).

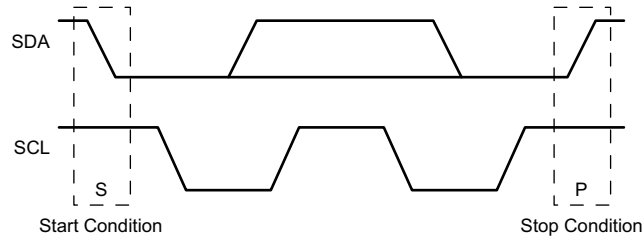
After receiving the valid address byte, this device responds with an acknowledge (ACK), a low on the SDA input/output during the high of the ACK-related clock pulse. On the I<sup>2</sup>C bus, only one data bit is transferred during each clock pulse. The data on the SDA line must remain stable during the high pulse of the clock period as changes in the data line at this time are interpreted as control commands (Start or Stop). The controller sends a Stop condition, a low-to-high transition on the SDA input/output while the SCL input is high.

Any number of data bytes can be transferred from the transmitter to receiver between the Start and the Stop conditions. Each byte of eight bits is followed by one ACK bit. The transmitter must release the SDA line before the receiver can send an ACK bit. The device that acknowledges must pull down the SDA line during the ACK clock pulse, so that the SDA line is stable low during the high pulse of the ACK-related clock period. When a

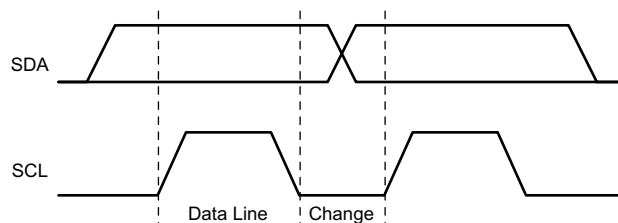
target receiver is addressed, it must generate an ACK after each byte is received. Similarly, the controller must generate an ACK after each byte that it receives from the target transmitter. Setup and hold times must be met to ensure proper operation.

A controller receiver signals an end of data to the target transmitter by not generating an acknowledge (NACK) after the last byte has been clocked out of the target. The controller receiver holding the SDA line high does this. In this event, the target transmitter must release the data line to enable the controller to generate a Stop condition.

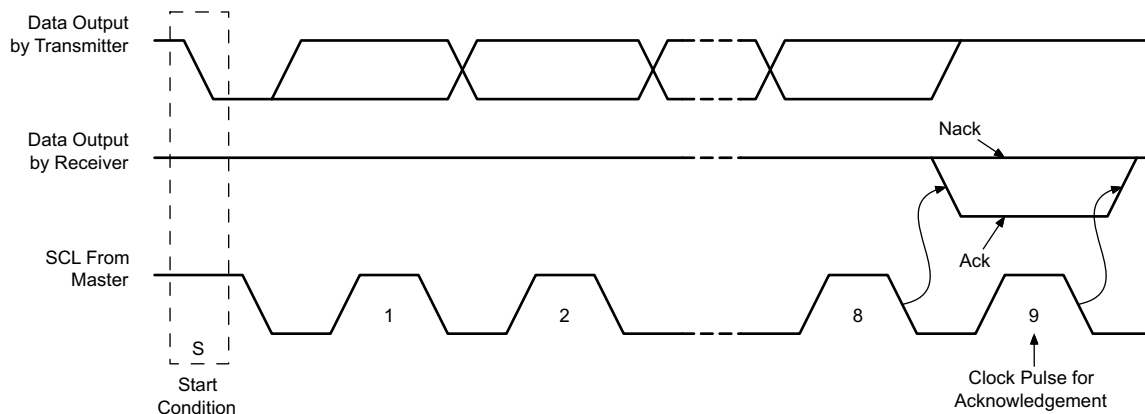
Figure 8-35 shows the start and stop conditions of the transfer. Figure 8-36 shows the SDA and SCL signals for transferring a bit. Figure 8-37 shows a data transfer sequence with the ACK or NACK at the last clock pulse.



**Figure 8-35. I<sup>2</sup>C Definition of Start and Stop Conditions**



**Figure 8-36. I<sup>2</sup>C Bit Transfer**



**Figure 8-37. I<sup>2</sup>C Acknowledgment**

### 8.3.11.2 I<sup>2</sup>C Clock Stretching

Clock stretching for I<sup>2</sup>C2. The target I<sup>2</sup>C port may hold the clock line (SCL) low after receiving (or sending) a byte, indicating that it is not yet ready to process more data. The controller communicating with the target must not finish the transmission of the current bit and must wait until the clock line actually goes high. When the target is clock stretching, the clock line remains low.

The controller must wait until it observes the clock line transitioning high plus an additional minimum time (4 μs for standard 100-kbps I<sup>2</sup>C) before pulling the clock low again.

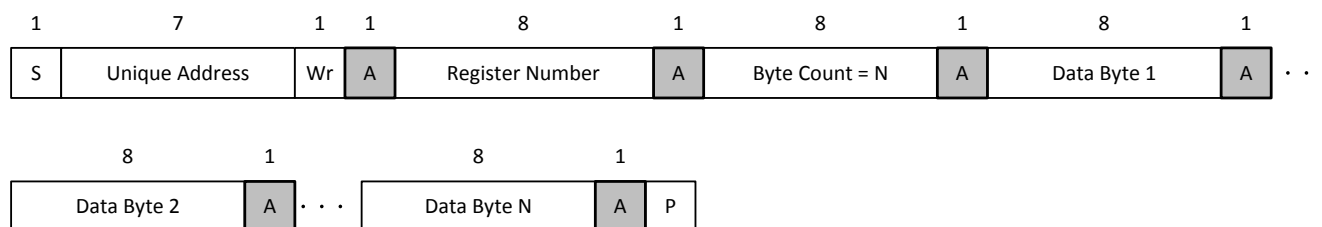
Any clock pulse may be stretched but typically it is the interval before or after the acknowledgment bit.

### 8.3.11.3 I<sup>2</sup>C Address Setting

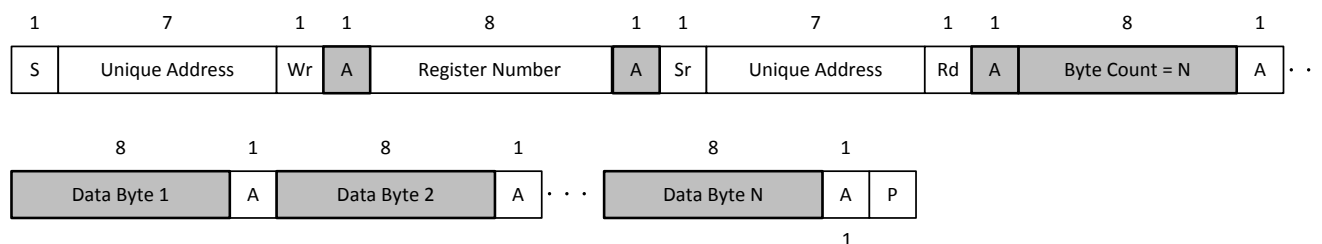
A HUB, MCU, or automotive processor host can use I<sup>2</sup>C\_SCL2 or I<sup>2</sup>C\_SDA2 for loading firmware patches or general status communication. Once the boot process is complete, each I<sup>2</sup>C port is assigned a unique target address as determined by the TVSP pin. The target address used by each port on the I<sup>2</sup>C bus are determined from the application configuration.

### 8.3.11.4 Unique Address Interface

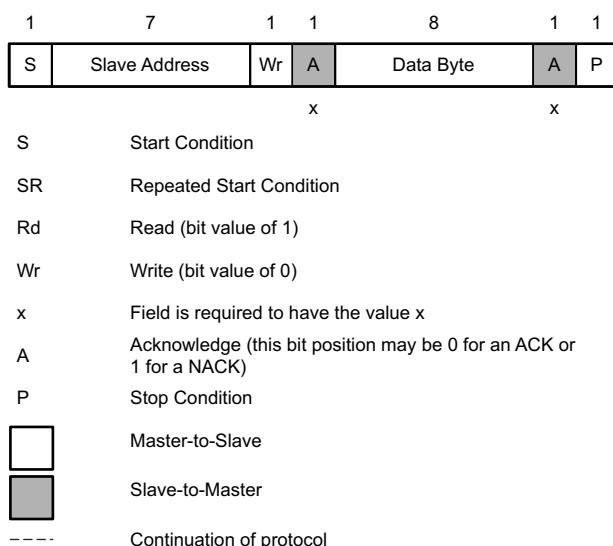
The Unique Address Interface allows for complex interaction between an I<sup>2</sup>C controller and a single TPS25762-Q1. The I<sup>2</sup>C target sub-address is used to receive or respond to Host Interface protocol commands. Figure 8-38 and Figure 8-39 show the write and read protocol for the I<sup>2</sup>C target interface, and a key is included in Figure 8-40 to explain the terminology used. The key to the protocol diagrams is in the SMBus Specification and is repeated here in part.



**Figure 8-38. I<sup>2</sup>C Unique Address Write Register Protocol**



**Figure 8-39. I<sup>2</sup>C Unique Address Read Register Protocol**



**Figure 8-40. I<sup>2</sup>C Read/Write Protocol Key**

### 8.3.11.5 I<sup>2</sup>C Pullup Resistor Calculation

Typical value for R<sub>P</sub>, the I<sup>2</sup>C pullup resistor is given by:

$$R_p = t_r / (0.8473 \times C_b)$$

Refer to [Table 8-12](#) for values of  $t_r$ ,  $C_b$  and  $V_{OL}$ .

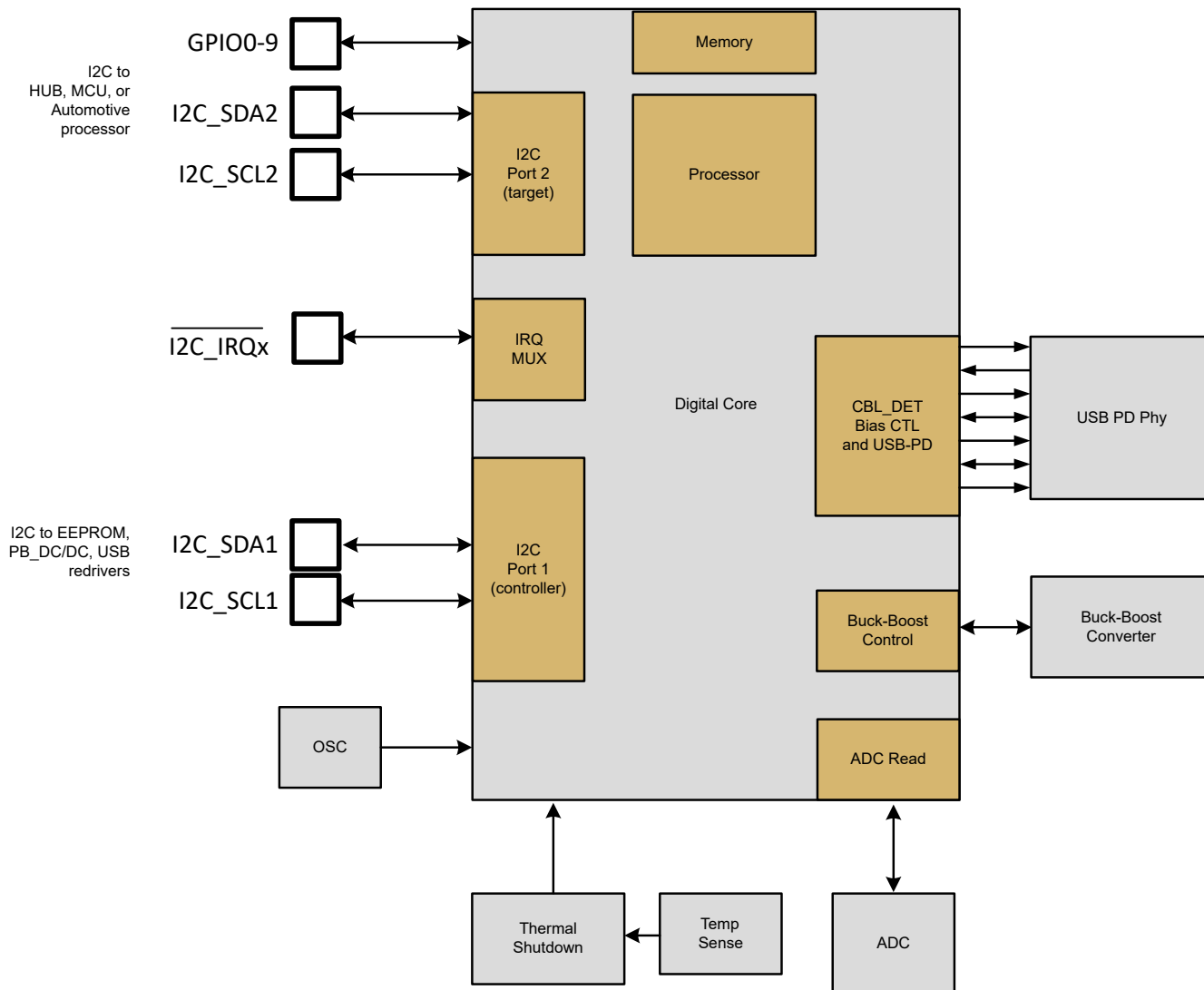
**Table 8-12. Parametrics from I2C Specifications**

Parameter		Standard Mode (Max)	Fast Mode (Max)	Fast Mode Plus (Max)	Unit
$f_{SCL}$	SCL clock frequency	100	400	1000	kHz
$t_r$	Rise time of both SDA and SCL signals	1000	300	120	ns
$C_b$	Capacitive load for each bus line	400	400	550	pF
$V_{OL}$	Low-level output voltage (at 3-mA current sink, $V_{DD} > 2\text{ V}$ )	0.4	0.4	0.4	V
	Low-level output voltage (at 2-mA current sink, $V_{DD} \leq 2\text{ V}$ )	–	$0.2 \times V_{DD}$	$0.2 \times V_{DD}$	V

For additional background regarding I2C pullup resistor calculations, please refer to application report, [I<sup>2</sup>C Bus Pullup Resistor Calculation](#).

### 8.3.12 Digital Core

Figure 8-41 shows a simplified block diagram of the digital core.



**Figure 8-41. Digital Core Simplified Block Diagram**

#### 8.3.12.1 Device Memory

The digital core contains a combination of ROM, SRAM, and OTP. ROM and SRAM function as the storage and operational space for application firmware. OTP contains boot configuration settings. There are 27 kBytes of SRAM, 160 kBytes of ROM, and 512 bytes of OTP.

#### 8.3.12.2 Core Microprocessor

The digital core is an ARM M0+ clocked at 24MHz with zero wait states.

#### 8.3.13 NTC Input

The NTC pin is used by the device firmware to monitor system temperature. Rising or falling voltages on the NTC pin indicate increasing or decreasing system temperatures, respectively. To achieve a positive temperature slope on the TPS25762-Q1 NTC pin, thermistors can be connected to LDO\_3V3 as shown in Figure 8-42.

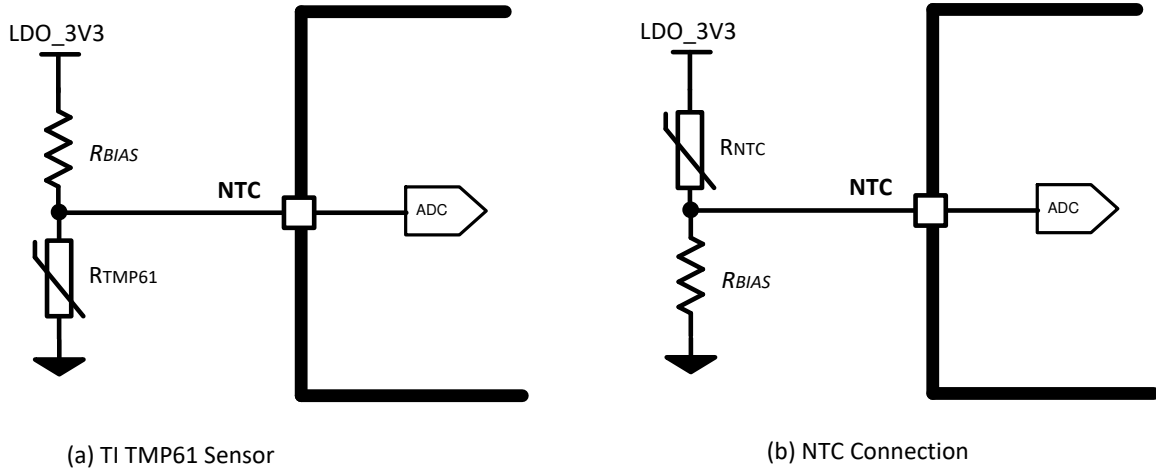


Figure 8-42. Thermistor Connections (a) PTC, (b) NTC

See Figure 8-43 and Figure 8-44. Using the application configuration GUI, the user can configure system power management responses for up to three  $V_{NTC}$  voltages.

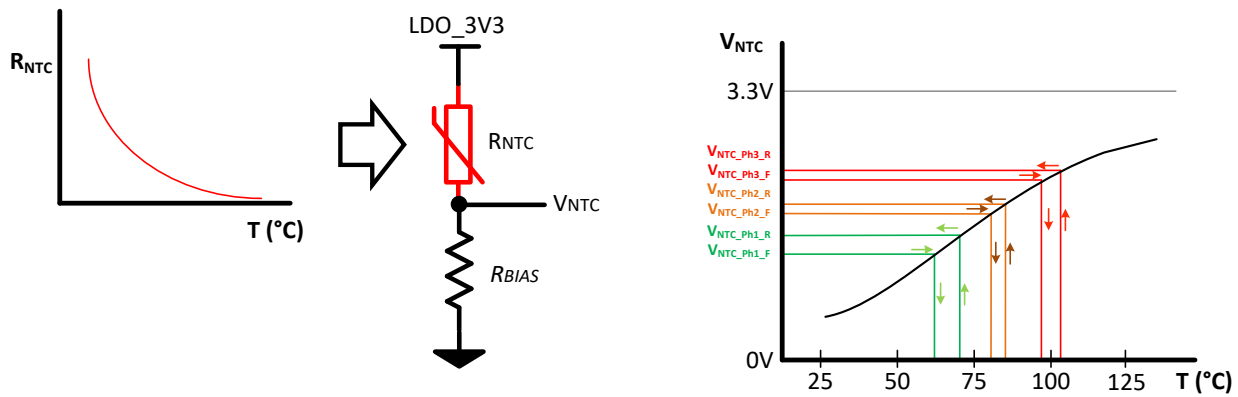


Figure 8-43. NTC Response Curve

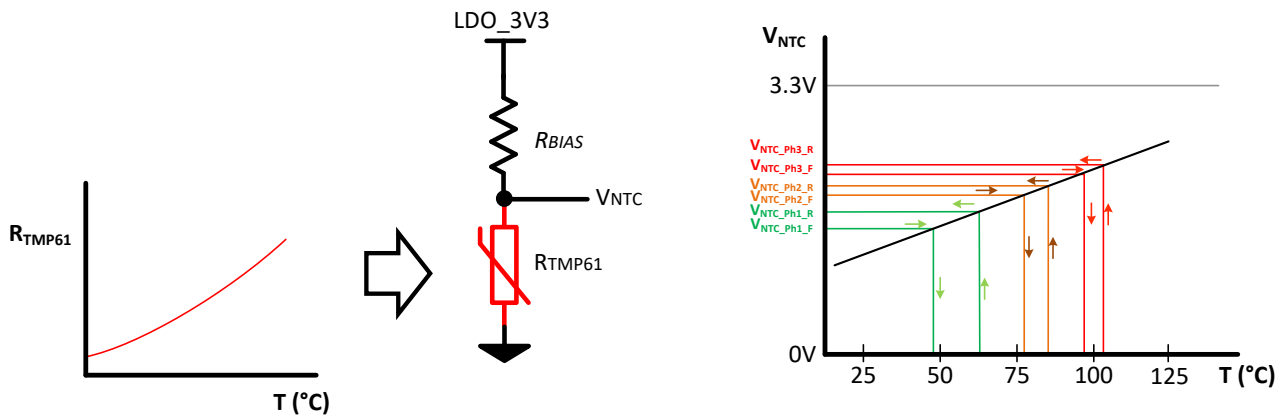


Figure 8-44. TMP61 PTC Response Curve

### Note

For optimum accuracy, use the  $V_{LDO\_3V3}$  specifications in *Electrical Characteristics* tables when performing resistor divider calculations.

### 8.3.14 Thermal Sensors and Thermal Shutdown

There are five internal thermal sensors in the TPS25762-Q1 devices:

- $T_{SD\_BB}$ . Two diode OR'ed thermal sensors to monitor buck-boost power FETs. Disables buck-boost regulator when asserted. USB-PD engine enters error recovery.
- $T_{SD\_PA\_VCONN}$ . One thermal sensor located in the PA\_VCONN path. Opens PA\_VCONN FET during over-temperature event. USB-PD engine enters error recovery.
- $T_{SD\_PA\_VBUS\_DISCH}$ . One thermal sensor located in the PA\_VBUS discharge path. Opens PA\_VBUS discharge FET during over-temperature. Closes PA\_VBUS discharge FET when temperature decreases below falling hysteresis. ( $T_{SD\_HYS}$ ) if PA\_VBUS is above discharge threshold set by firmware during decreasing VBUS transition.
- $T_{SD\_LDO5V}$ . One thermal sensor located in the LDO\_5V regulator. Operates as master thermal shutdown. Disables device completely during over-temperature events causing M0 to hard reset. Allows device operation when temperature decreases below falling hysteresis ( $T_{SD\_HYS}$ ).

## 8.4 Device Functional Modes

### Shutdown Mode

The EN/UVLO pin provides electrical ON and OFF control for the TPS25762-Q1. When  $V_{EN/UVLO}$  is below 1.15 V (typ), the device is in shutdown mode in which the Cortex M0 is disabled and only minimal analog functions are operating. Refer to [VIN UVLO and Enable/UVLO](#) section for the detailed description of the EN/UVLO pin functionality.

### Active Mode

The TPS25762-Q1 enters active mode when  $V_{EN/UVLO}$  is above its rising threshold,  $V_{EN(OPER)}$ , and the supply voltage on the IN pin is above the  $V_{IN}$  undervoltage lockout threshold,  $V_{IN(UVLO\_R)}$ . In active mode, the internal analog circuits are fully operational with the M0 enabled and executing firmware from ROM.

At the onset of active mode, firmware boot code attempts to measure the resistance on the TVSP pin and decode a TVSP Index value. Upon successful configuration and firmware patch load, the device is ready to begin operation per configuration settings stored on the external EEPROM. If the configuration and patch data do not load successfully due to communications error the device continues to operate with only Port A enabled with standard Type-C functionality. Index value 8 is reserved for use when updating device configuration and firmware patch information through the TPS25762-Q1 GUI and Port A connection. Once device boot is complete, device firmware controls and manages USB connections in accordance with loaded application configuration settings.

## 9 Application and Implementation

### Note

Information in the following applications sections is not part of the TI component specification, and TI does not warrant its accuracy or completeness. TI's customers are responsible for determining suitability of components for their purposes, as well as validating and testing their design implementation to confirm system functionality.

### 9.1 Application Information

The TPS25762-Q1 application configuration GUI provides default application settings.

The most common implementations are single port USB PD charger and single port USB PD with USB HUB. Refer to [TPS25762DQ1EVM Evaluation Module User's Guide](#) for detailed design information. Consult the [TPS257XX-Q1-GUI Configuration Guide](#) and application GUI [TPS257XX-Q1-GUI](#) for system configuration options.

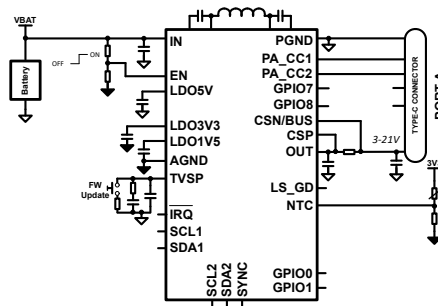


Figure 9-1. Simplified Single USB PD Charger

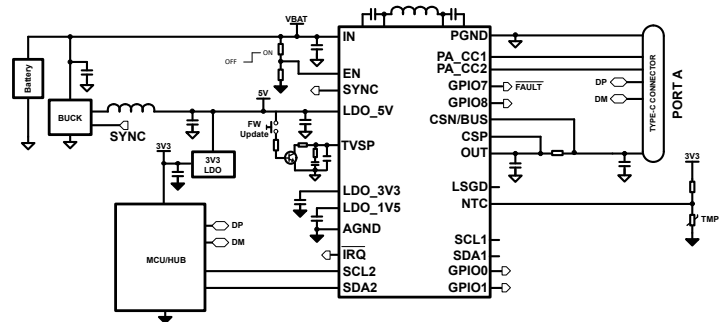


Figure 9-2. Simplified Single USB PD with MCU/HUB

[Typical Application](#) describes a detailed step-by-step design procedure for a typical charger application circuit.

### 9.2 Typical Application

Figure 9-3 Shows a typical example of a 65 W output automotive USB Type-C Power Delivery port. The device is internally compensated and optimized for components shown in [Table 9-1](#).

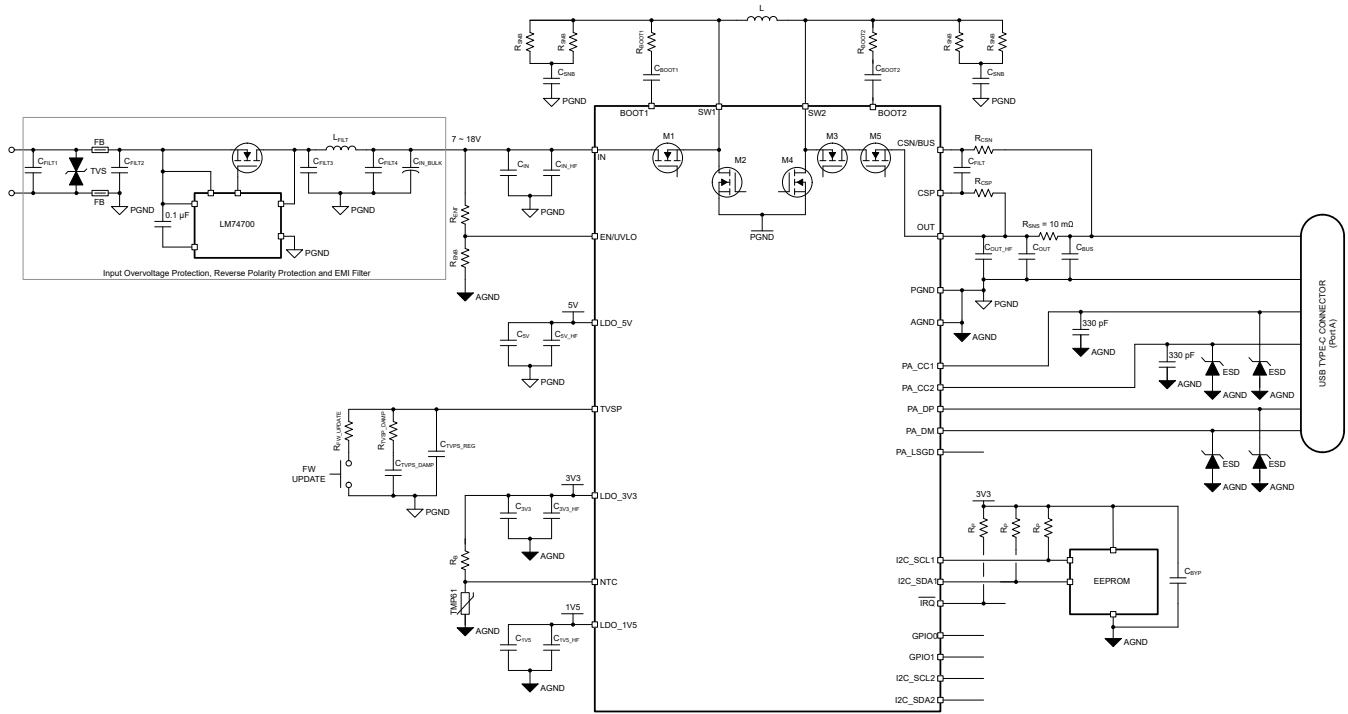
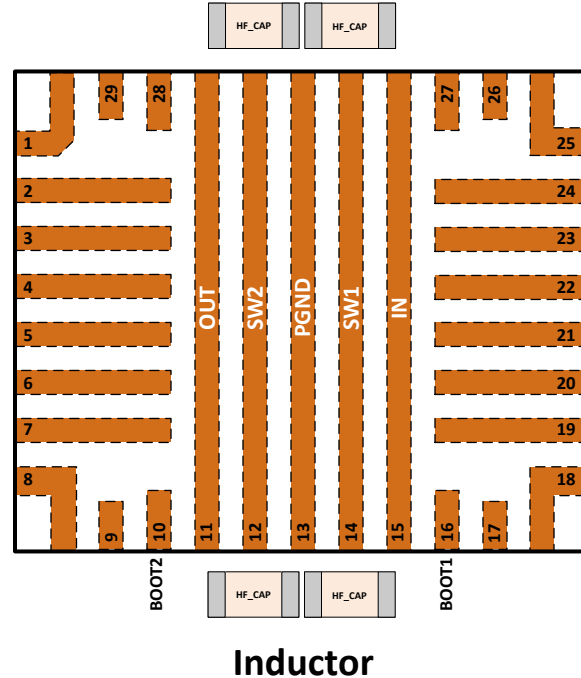


Figure 9-3. TPS25762-Q1 Application Schematic

Table 9-1. Recommended Inductors, Input and Output Capacitance

f <sub>sw</sub>	C <sub>IN</sub> + C <sub>HF</sub>	L	MIN of C <sub>OUT</sub> + C <sub>BUS</sub>	C <sub>OUT</sub> + C <sub>HF</sub>	C <sub>BUS</sub>
300	22 μF + 2 × 0.1 μF	4.7 μH	160 μF	30 μF + 2 × 0.1 μF	130 μF + 2 × 0.1 μF
400	22 μF + 2 × 0.1 μF	4.7 μH	120 μF	30 μF + 2 × 0.1 μF	90 μF + 2 × 0.1 μF
400	22 μF + 2 × 0.1 μF	3.3 μH	140 μF	30 μF + 2 × 0.1 μF	110 μF + 2 × 0.1 μF
450	22 μF + 2 × 0.1 μF	3.3 μH	140 μF	30 μF + 2 × 0.1 μF	110 μF + 2 × 0.1 μF

- 50 V rated capacitors recommended.



**Figure 9-4. Input and Output  $C_{HF}$  Capacitor Placement**

To ensure adequate decoupling of  $V_{IN}$  and  $V_{OUT}$  and robust device operation, use two  $0.1 \mu\text{F}$ ,  $C_{HF}$  capacitors per node, placed on opposite sides of the IC package, as close to the pins as possible. Typically, the inductor is placed on the same PCB layer (top or bottom) as the IC package. The  $C_{HF}$  capacitors on the inductor end of the IC package may be placed on the opposite side of the PCB (bottom or top) using vias to minimize trace length from the inductor side IN and OUT pins to the physical location of these capacitors.

**Table 9-2. Recommended SWx Snubber and Current Sense Filter Components**

SW1 <sup>(1)</sup>		SW2 <sup>(2)</sup>		CSP & CSN Filter <sup>(3)</sup>		
$R_{SNB}$ (0.25 W)	$C_{SNB}$ (50 V)	$R_{SNB}$ (0.25 W)	$C_{SNB}$ (50 V)	$R_{CSP}$ (0.1 W)	$R_{CSN}$ (0.1 W)	$C_{FLT}$ (50 V)
$2.2 \Omega \parallel 2.2 \Omega$	1 nF	$2.2 \Omega \parallel 2.2 \Omega$	3.3 nF	10 $\Omega$	0 $\Omega$	0.22 $\mu\text{F}$

1. As needed for EMI mitigation - user optional. (Use of this snubber can also aid in supporting devices with high initial inrush load current that exceeds the power delivery specification.)
2. **Required** for robust device operation.
3. **Required** to meet USB-IF current regulation requirements.

### 9.2.1 Design Requirements

For this example, [Table 9-3](#) are used as the target parameters.

**Table 9-3. Design Inputs**

DESIGN PARAMETER	EXAMPLE VALUE
Input Voltage Range	6.8 V to 18 V (transients to 36 V)
UVLO Turn on Voltage	6.5 V
USB PD Power	65 W
USB PD $V_{BUS}$ Voltages	5 V, 9 V, 15 V, 20 V and 3.3 to 21 V (PPS)
Output	3.3 - 21 V
Load Current	PDO: 5 V, 3 A; 9 V, 3 A; 15 V, 3 A, 20 V, 3.25 A APDO: 3.3 - 21 V, 3 A
Switching Frequency	400 kHz
$V_{CONN}$	0.1 W

**Table 9-3. Design Inputs (continued)**

DESIGN PARAMETER	EXAMPLE VALUE
Automotive Module Maximum Current	15 A

## 9.2.2 Detailed Design Procedure

### 9.2.2.1 Application GUI Selections

Use the application GUI to select the desired operating conditions. Once complete, save the settings to the programming PC, flash the firmware to EEPROM, and power cycle device. Once complete the TPS25762-Q1 is ready for operation.

**Table 9-4. Application GUI Selections**

PARAMETER	GUI SELECTION
<b>BUCK-BOOST AND USB INPUTS</b>	
Port A $V_{BUS}$ Power	65 W
Port A PDOs and APDOs	PDO: 5 V, 3 A; 9 V, 3 A; 15 V, 3 A; 20 V, 3.25 A APDO: 3.3 - 21 V, 3A
Port A $V_{CONN}$ Power	0.1 W
$f_{SW}$ Switching Frequency	400 kHz
L Inductor	4.7 $\mu$ H
Automotive Module Maximum Current	15 A
<b>LOW BATTERY INPUTS</b>	
Engine ON voltage	12.5 V
Engine OFF voltage	11 V
Run timer after engine off	600 seconds
<b>THERMAL MANAGEMENT INPUTS</b>	
$V_{NTC\_PHASE1}$	1.65 V
NTC_PHASE1 Power as Percentage of MAX	50 %
$V_{NTC\_PHASE2}$	2.1 V
NTC_PHASE2 Power as Percentage of MAX	30 %
$V_{NTC\_PHASE3}$	2.4 V
NTC_PHASE3 Power as Percentage of MAX	0 % (disable PA_VBUS)

### 9.2.2.2 EEPROM Selection

An EEPROM is required to store user application configuration data as any firmware patch updates released by Texas Instruments during the life of the product.

Basic requirements:

- 32kB (256kb)
- 7 Bit I2C address (0x50)
- Organization: 32kb x 8 (totals 256kb)
- Active firmware image is stored in one 16kb x 8 partition. The previous firmware image is retained in the other 16kb x 8 partition for reliability.
- Page size/buffer must be 64b

**Table 9-5. Suggested EEPROMs**

Manufacturer	Part Number
On Semi	CAV24C256
Microchip	24LC256
ST Micro	M24256
Rohm	BRA24T512=3AM

### 9.2.2.3 EN/UVLO

The TPS25762-Q1 has a fixed  $V_{IN(UVLO)}$  with rising and falling thresholds between 5 and 5.5 V, refer to Buck-Boost Regulator for exact values. The falling threshold,  $V_{IN(UVLO\_F)}$ , disables the device when the battery voltage is too low for continued operation. To establish a turn on voltage higher than  $V_{IN(UVLO\_R)}$ , connect a resistor divider from the IN supply voltage to the EN/UVLO pin. When  $V_{EN/UVLO} > V_{EN(OPER)}$ , nominally 1.25 V, the device exits low power shutdown and begins to startup.

In this example a  $V_{IN}$  turn on voltage of approximately 6.5 V is required. Use the equations and examples below to determine the required resistor values.

- Choose standard value  $R_{ENB} = 22 \text{ k}\Omega$ .
- Calculate  $R_{ENT}$

$$R_{ENT} = \left( \frac{V_{ON}}{V_{EN(OPER)}} - 1 \right) \times R_{ENB} \quad (3)$$

$$R_{ENT} = \left( \frac{6.5 \text{ V}}{1.25 \text{ V}} - 1 \right) \times 22 \text{ k}\Omega = 92.4 \text{ k}\Omega \quad (4)$$

- Select a standard value of 91 k $\Omega$ .
- Using 22 k $\Omega$  and 91 k $\Omega$ . Rearranging [Equation 3](#) results in

$$V_{ON} = \left( \frac{R_{ENT}}{R_{ENB}} + 1 \right) \times V_{EN(OPER)} \quad (5)$$

$$V_{ON} = \left( \frac{91 \text{ k}\Omega}{22 \text{ k}\Omega} + 1 \right) \times 1.25 \text{ V} = 6.42 \text{ V} \quad (6)$$

- Calculate  $V_{OFF}$

$$V_{OFF} = \left( 1 - \frac{V_{EN(HYS)}}{V_{EN(OPER)}} \right) \times V_{ON} \quad (7)$$

$$V_{OFF} = \left( 1 - \frac{0.1 \text{ V}}{1.25 \text{ V}} \right) \times 6.42 \text{ V} = 5.91 \text{ V} \quad (8)$$

- Lastly, confirm the selected resistors do not trigger the EN/UVLO pin MAX clamp voltage. Assuming 36 V as a maximum  $V_{IN}$  transient.

$$V_{EN/UVLO(MAX)} = \left( \frac{V_{IN(MAX)} \times R_{ENB}}{R_{ENT} + R_{ENB}} \right) \quad (9)$$

$$V_{EN/UVLO(MAX)} = \left( \frac{36 \text{ V} \times 22 \text{ k}\Omega}{22 \text{ k}\Omega + 91 \text{ k}\Omega} \right) = 7 \text{ V} \quad (10)$$

- The result, 7 V, is less than the EN/UVLO pin maximum clamp voltage.

### 9.2.2.4 Sense Resistor, $R_{SNS}$ , $R_{CSP}$ , $R_{CSN}$ and $C_{FILT}$

The TPS25762-Q1 requires a 10-m $\Omega$  resistance between the CSP and CSN/BUS pins. For accurate current limit regulation,  $\pm 1\%$  precision or better is required. For a DC output current of 3.25 A, the power dissipation in the resistor is

$$I^2R, \text{ or } (3.25 \text{ A})^2 \times 0.01 \Omega = 0.106 \text{ W.}$$

A power resistor with 0.33-W rating,  $\pm 1\%$  tolerance and 2010 case is chosen. *Check the manufacturers power derating curves when selecting the component. Most derate maximum power above 70°C.*

An RC filter network is required on the CSP and CSN/BUS pins for proper USB PD PPS current limit accuracy. A filter network with  $R_{CSP} = 10 \Omega$ ,  $R_{CSN} = 0 \Omega$ , and filter capacitor,  $C_{FILT} = 0.22 \mu\text{F}$  is recommended. Suggested RC filter component ratings are shown in [Table 9-2](#).  $R_{CSN}$  must be zero ohm to avoid interfering with the  $V_{BUS}$  discharge functionality.

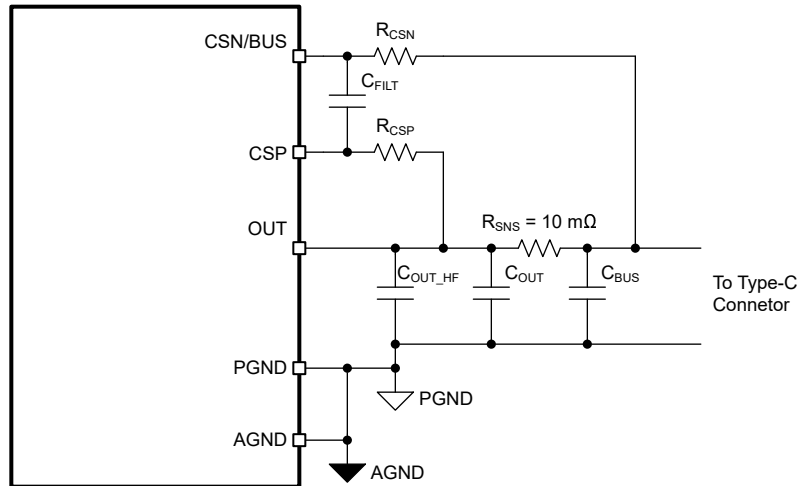


Figure 9-5. Current Sense Amplifier: RC Filter Components

### 9.2.2.5 Inductor Currents

Table 9-1 lists recommended inductor values based on desired switching frequency,  $f_{SW}$ . The following equations were used to derive the values in the *Buck Calculation* and *Boost Calculation* results tables below.

$$D_{BUCK} = \frac{V_{OUT}}{V_{IN(MAX)} \times \eta} \tag{11}$$

$$D_{BOOST} = 1 - \frac{V_{IN(MIN)} \times \eta}{V_{OUT}} \tag{12}$$

where

- $V_{IN(MAX)}$  = maximum input voltage
- $V_{IN(MIN)}$  = minimum input voltage
- $V_{OUT}$  = output voltage
- $D_{BUCK}$  = minimum duty cycle for buck mode
- $D_{BOOST}$  = maximum duty cycle for boost mode
- $\eta$  = estimated efficiency calculated at  $V_{IN}$ ,  $V_{OUT}$ , and  $I_{OUT}$

Buck Mode

$$I_{SW\_BUCK(MAX)} = \frac{\Delta I_{L\_BUCK(MAX)}}{2} + I_{OUT} \tag{13}$$

$$\Delta I_{L\_BUCK(MAX)} = \frac{(V_{IN(MAX)} - V_{OUT(MIN)}) \times D_{BUCK}}{f_{SW} \times L} \tag{14}$$

where

- $V_{IN(MAX)}$  = maximum input voltage
- $V_{OUT(MIN)}$  = minimum output voltage
- $I_{OUT}$  = maximum DC output current
- $\Delta I_{L\_BUCK(MAX)}$  = maximum ripple current through the inductor when in buck operation

- $I_{SW\_BUCK(MAX)}$  = maximum switch current when in buck operation
- $D_{BUCK}$  = minimum duty cycle for buck operation
- $f_{SW}$  = switching frequency of the converter
- $L$  = selected inductor value

$$I_{MAXOUT(BUCK)} = I_{PEAK(BUCK)} - \frac{\Delta I_{L\_BUCK(MAX)}}{2} \quad (15)$$

where

- $I_{MAXOUT(BUCK)}$  = maximum deliverable current through inductor by the converter
- $I_{PEAK(BUCK)}$  = buck switch peak current limit from *Electrical Characteristics* table
- $\Delta I_{L\_BUCK(MAX)}$  = Ripple current through the inductor calculated in [Equation 14](#).

Boost Mode

$$I_{SW\_BOOST(MAX)} = \frac{\Delta I_{L\_BOOST(MAX)}}{2} + \frac{I_{OUT}}{1 - D_{BOOST}} \quad (16)$$

$$\Delta I_{L\_BOOST(MAX)} = \frac{V_{IN(MIN)} \times D_{BOOST}}{f_{SW} \times L} \quad (17)$$

where

- $V_{IN(MIN)}$  = minimum input voltage
- $V_{OUT(MAX)}$  = desired output voltage
- $I_{OUT}$  = desired output current
- $\Delta I_{L\_BOOST(MAX)}$  = maximum ripple current through the inductor in boost operation
- $I_{SW\_BOOST(MAX)}$  = maximum switch current in boost operation
- $D_{BOOST}$  = maximum duty cycle for boost operation
- $f_{SW}$  = switching frequency of the converter
- $L$  = selected inductor value

$$I_{MAXOUT(BOOST)} = \left( I_{PEAK(BOOST)} - \frac{\Delta I_{L\_BOOST(MAX)}}{2} \right) \times (1 - D_{BOOST}) \quad (18)$$

where

- $I_{MAXOUT(BOOST)}$  = maximum deliverable current through inductor by the converter
- $D_{BOOST}$  = maximum duty cycle for boost mode
- $I_{PEAK(BOOST)}$  = boost switch peak current limit from *Electrical Characteristics* table
- $\Delta I_{L\_MAX(BOOST)}$  = Ripple current through the inductor calculated in [Equation 17](#).

### Buck Operation

[Table 9-6](#) provides the tabulated  $\Delta I_{L\_BUCK(MAX)}$  and  $I_{SW\_BUCK(MAX)}$  for the conditions below.

- $\eta = 0.95$
- $V_{IN(MAX)} = 18 \text{ V}$
- $V_{OUT(MIN)} = 3.3 \text{ V}$
- $D_{BUCK(MIN)} = 0.193$

**Table 9-6. Buck Calculation Results (L = 4.7  $\mu$ H), I<sub>BUS</sub> = 3 A**

f <sub>sw</sub> (kHz)	I <sub>OUT</sub> (A)	$\Delta I_{L\_BUCK(MAX)}$ (A)	I <sub>SW\_BUCK(MAX)</sub> (A)
300	3.00	2.87	4.44
400	3.00	2.15	4.08
450	3.00	1.91	3.96
300	3.00	2.01	4.01
400	3.00	1.51	3.76
450	3.00	1.34	3.67

### Boost Operation

Table 9-6 provides the tabulated  $\Delta I_{L\_BOOST(MAX)}$ , I<sub>SW\\_BOOST(MAX)</sub>, suggested GUI I<sub>PEAK(BOOST)</sub> (MIN) settings for the maximum output power conditions shown below.

If I<sub>SW\\_BOOST(MAX)</sub> > I<sub>PEAK(BOOST)</sub> (MIN) → V<sub>BUS</sub> dropout likely.

If I<sub>SW\\_BOOST(MAX)</sub> < I<sub>PEAK(BOOST)</sub> (MIN) → V<sub>BUS</sub> regulates normally.

- $\eta = 0.95$
- V<sub>IN(MIN)</sub> = 5.5 V to 9 V
- V<sub>OUT(MAX)</sub> = 21 V
- I<sub>OUT</sub> = 3 A

To be noted, the calculation here uses 21V 3 A instead of 20 V 3.25A because 21 V 3A has bigger inductor peak current.

**Table 9-7. Boost Calculation Results (L = 4.7  $\mu$ H), I<sub>BUS</sub> = 3 A**

f <sub>sw</sub> (kHz)	V <sub>IN(MIN)</sub> (V)	D <sub>BOOST(MAX)</sub>	$\Delta I_{L\_BOOST(MAX)}$ (A)	I <sub>SW\_BOOST(MAX)</sub> (A)	GUI <sup>(1)</sup> I <sub>PEAK(BOOST)</sub> (A)
300	5.5	0.751	2.93	13.51	12.3
	6	0.729	3.10	12.62	12.3
	6.5	0.706	3.25	11.83	12.3
	7	0.683	3.39	11.16	12.3
	7.5	0.661	3.52	10.61	10.8
	8	0.638	3.62	10.10	10.8
	8.5	0.615	3.71	9.65	10.8
	9	0.593	3.79	9.27	9.3
400	5.5	0.751	2.20	13.15	12.3
	6	0.729	2.33	12.24	12.3
	6.5	0.706	2.44	11.42	12.3
	7	0.683	2.54	10.73	10.8
	7.5	0.661	2.64	10.17	10.8
	8	0.638	2.71	9.64	10.8
	8.5	0.615	2.78	9.18	9.3
	9	0.593	2.84	8.79	9.3

**Table 9-7. Boost Calculation Results (L = 4.7 μH), I<sub>BUS</sub> = 3 A (continued)**

f <sub>sw</sub> (kHz)	V <sub>IN(MIN)</sub> (V)	D <sub>BOOST(MAX)</sub>	ΔI <sub>L_BOOST(MAX)</sub> (A)	I <sub>SW_BOOST(MAX)</sub> (A)	GUI <sup>(1)</sup> I <sub>PEAK(BOOST)</sub> (A)
450	5.5	0.751	1.95	13.02	12.3
	6	0.729	2.07	12.11	12.3
	6.5	0.706	2.17	11.29	12.3
	7	0.683	2.26	10.59	10.8
	7.5	0.661	2.34	10.02	10.8
	8	0.638	2.41	9.49	9.3
	8.5	0.615	2.47	9.03	9.3
	9	0.593	2.51	8.63	9.3

(1) MIN value of boost peak ILIM shown. See electrical characteristics table for MIN, TYP, MAX values.

### 9.2.2.6 Output Capacitor

In the boost mode, the output capacitor conducts high ripple current. The output capacitor RMS ripple current is given by Equation 19 where the minimum V<sub>IN</sub> corresponds to the maximum capacitor current.

$$I_{COUT(RMS)} = I_{OUT} \times \sqrt{\frac{V_{OUT}}{V_{IN}} - 1} \quad (19)$$

In this example the maximum output ripple RMS current is I<sub>COUT(RMS)</sub> = 3.18 A. A 5-mΩ output capacitor ESR causes an output ripple voltage of 34 mV as given by:

$$\Delta V_{RIPPLE(ESR)} = \frac{I_{OUT} \times V_{OUT}}{V_{IN(MIN)}} \times ESR \quad (20)$$

A 140 μF output capacitor (C<sub>OUT</sub> + C<sub>BUS</sub>) causes a capacitive ripple voltage of 26 mV as given by:

$$\Delta V_{RIPPLE(COUT)} = \frac{I_{OUT} \times \left(1 - \frac{V_{IN(MIN)}}{V_{OUT}}\right)}{C_{OUT} \times F_{sw}} \quad (21)$$

Typically a combination of ceramic and bulk capacitors is needed to provide low ESR and high ripple current capacity. The complete schematic in *Typical Application* section provides C<sub>OUT</sub> and C<sub>BUS</sub> recommendations suitable for most applications.

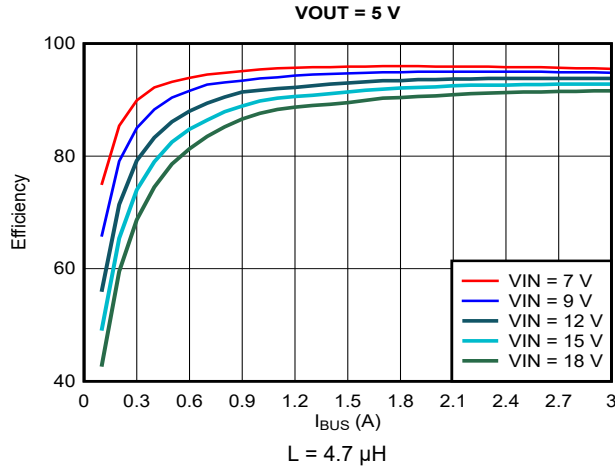
### 9.2.2.7 Input Capacitor

In the buck mode, the input capacitor supplies high ripple current. The RMS current in the input capacitor is given by:

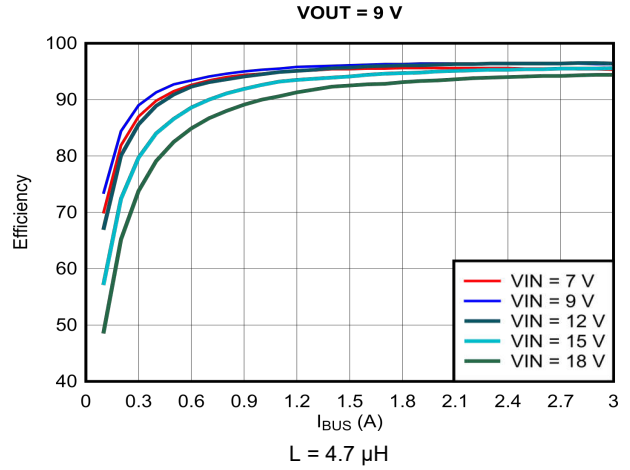
$$I_{CIN(RMS)} = I_{OUT} \sqrt{D \times (1 - D)} \quad (22)$$

The maximum RMS current occurs at D = 0.5, which gives I<sub>CIN(RMS)</sub> = I<sub>OUT</sub>/2 = 1.5 A. A combination of ceramic and bulk capacitors can be used to provide a short path for high di/dt current and to reduce the output voltage ripple. Table 9-1 in the *Typical Application* section is a good starting point for C<sub>IN</sub> selection.

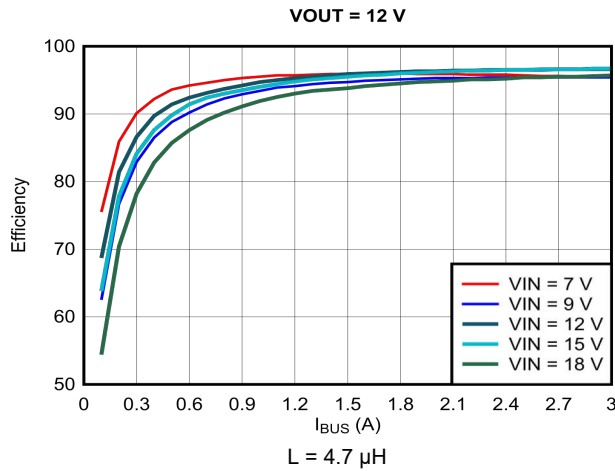
### 9.2.3 Application Curves



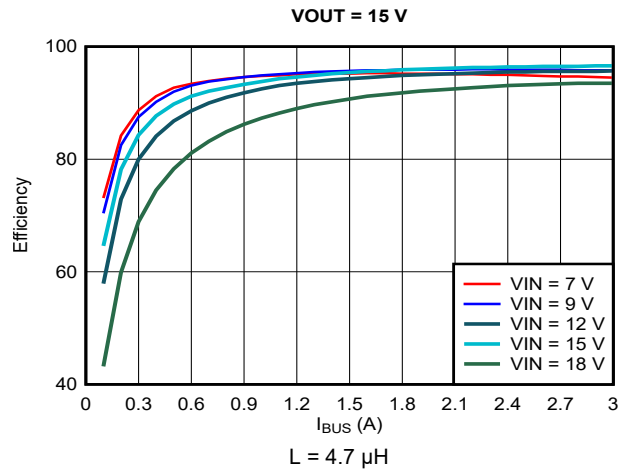
**Figure 9-6. Efficiency vs Output Current ( $I_{OUT}$ ),  $V_{OUT} = 5\text{ V}$**



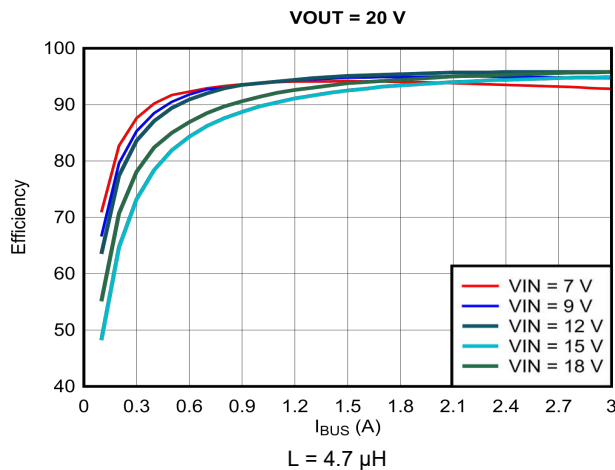
**Figure 9-7. Efficiency vs Output Current ( $I_{OUT}$ ),  $V_{OUT} = 9\text{ V}$**



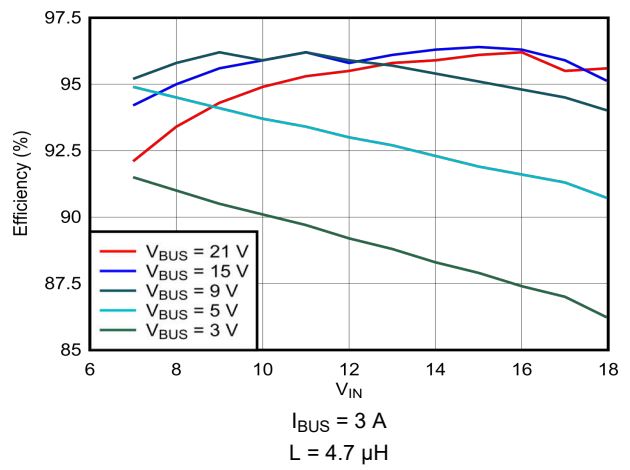
**Figure 9-8. Efficiency vs Output Current ( $I_{OUT}$ ),  $V_{OUT} = 12\text{ V}$**



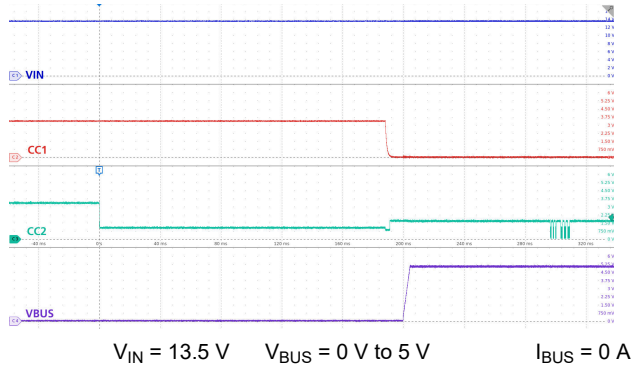
**Figure 9-9. Efficiency vs Output Current ( $I_{OUT}$ ),  $V_{OUT} = 15\text{ V}$**



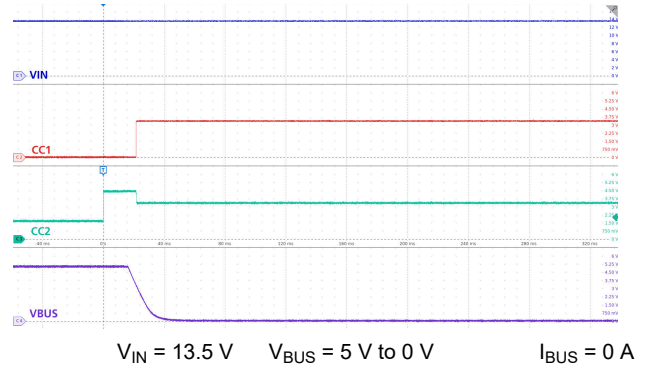
**Figure 9-10. Efficiency vs Output Current ( $I_{OUT}$ ),  $V_{OUT} = 20\text{ V}$**



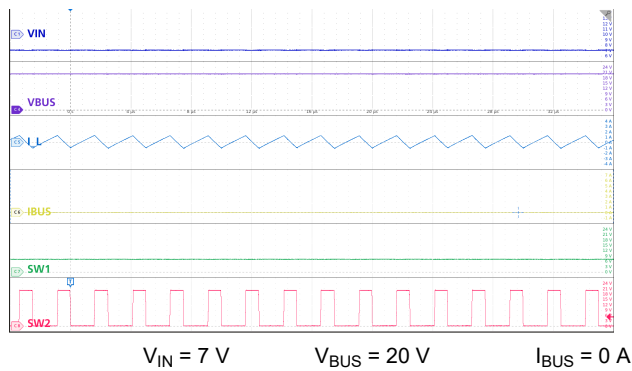
**Figure 9-11. Efficiency vs Input Voltage**



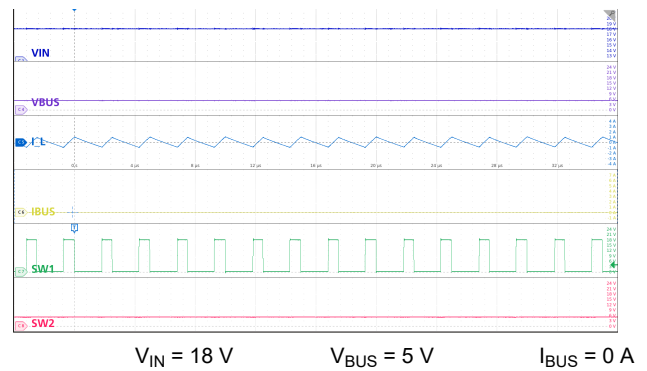
**Figure 9-12. Type-C Attach**



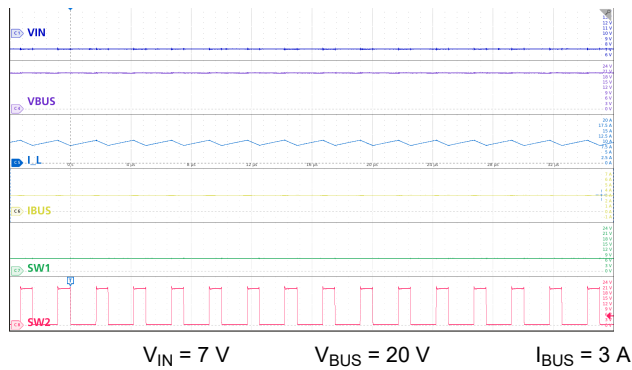
**Figure 9-13. Type-C Detach**



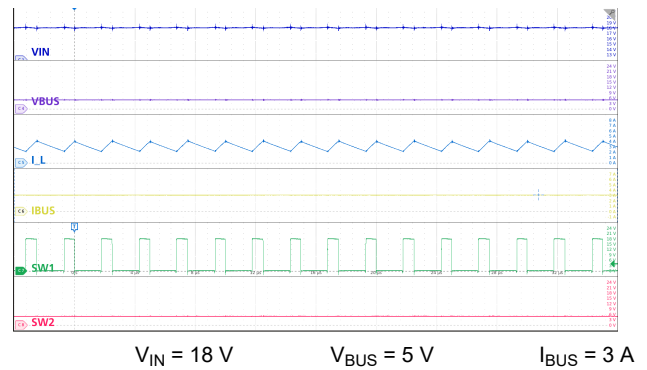
**Figure 9-14. Boost Mode: Low  $V_{IN}$ , No Load**



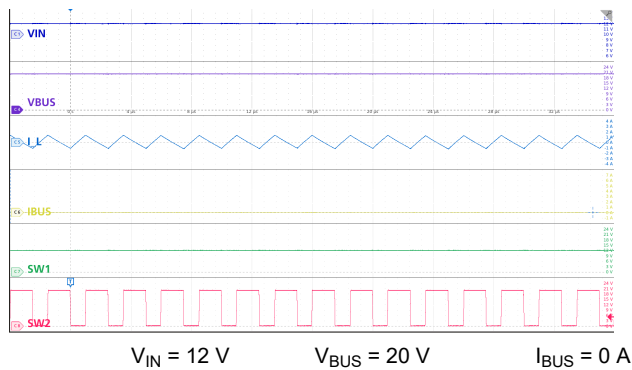
**Figure 9-15. Buck Mode: High  $V_{IN}$ , No Load**



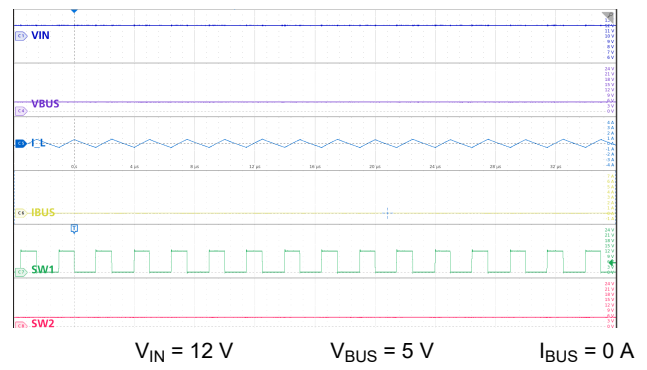
**Figure 9-16. Boost Mode: Low  $V_{IN}$ , 3 A Load**



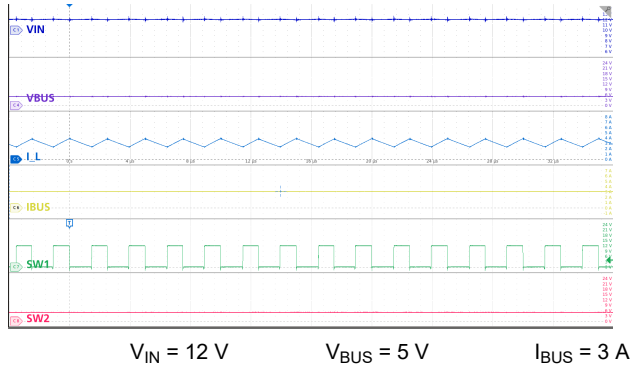
**Figure 9-17. Buck Mode: High  $V_{IN}$ , 3 A Load**



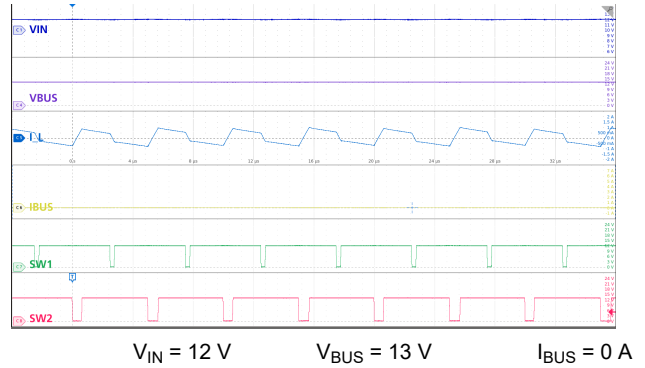
**Figure 9-18. Boost Mode: Nominal  $V_{IN}$ , No Load**



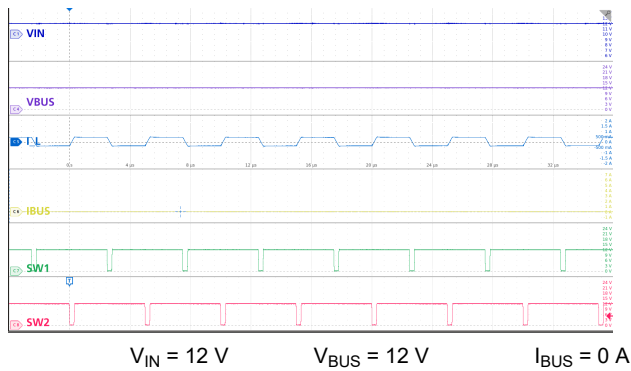
**Figure 9-19. Buck Mode: Nominal  $V_{IN}$ , No Load**



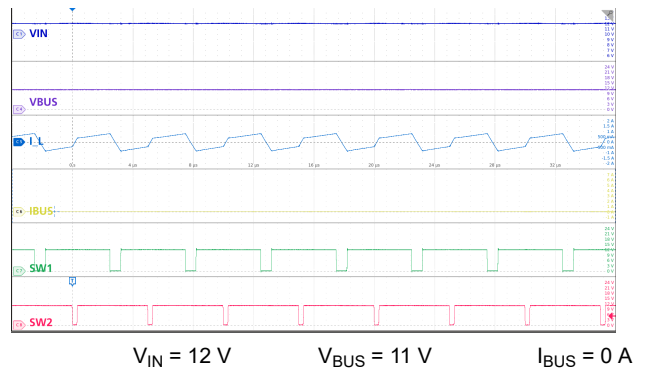
**Figure 9-20. Buck Mode: nominal  $V_{IN}$ , 3 A Load**



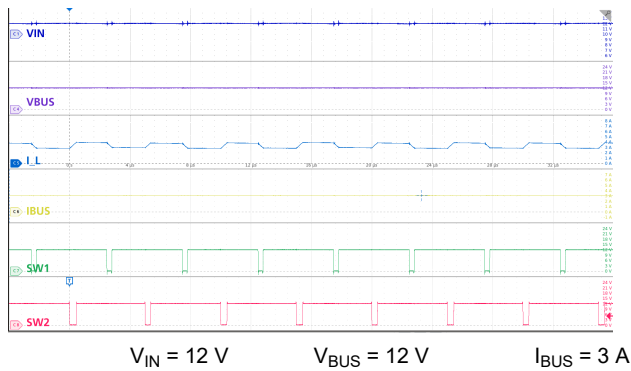
**Figure 9-21. Buck-Boost Mode:  $V_{IN} \neq V_{BUS}$ , No Load**



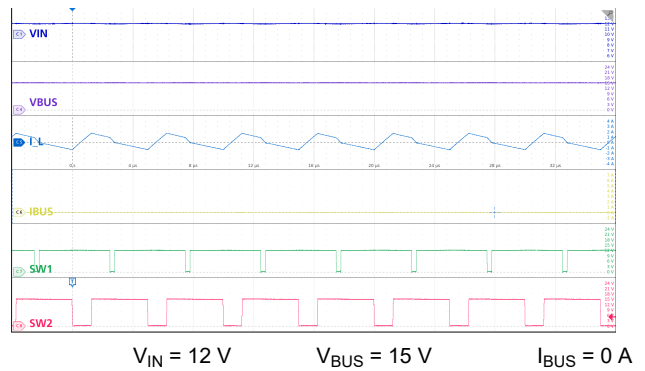
**Figure 9-22. Buck-Boost Mode:  $V_{IN} = V_{BUS}$ , No Load**



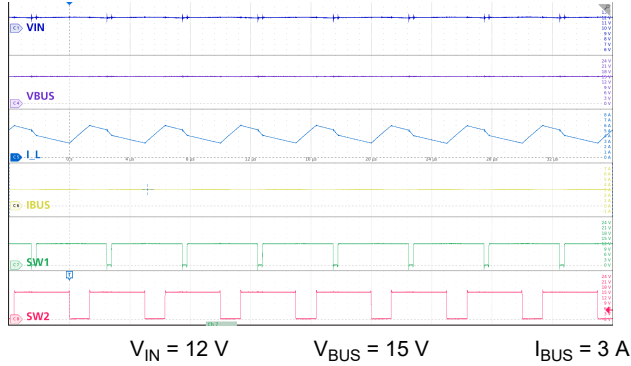
**Figure 9-23. Buck-Boost Mode:  $V_{IN} \neq V_{BUS}$ , No Load**



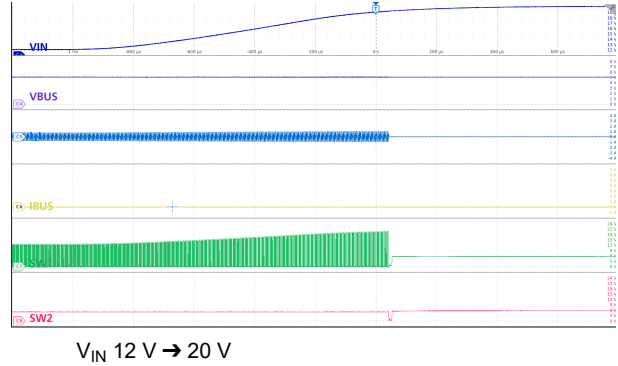
**Figure 9-24. Buck-Boost Mode:  $V_{IN} = V_{BUS}$ , 3 A Load**



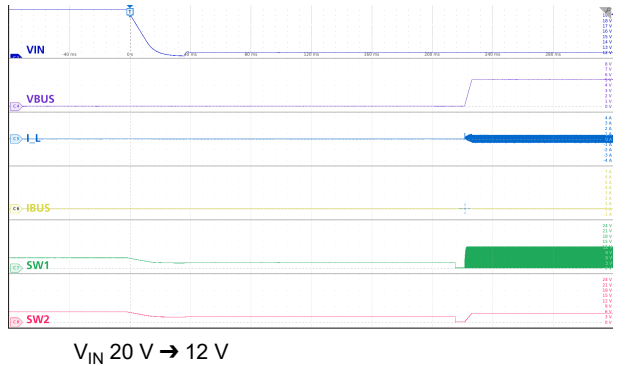
**Figure 9-25. Buck-Boost Mode: Nominal  $V_{IN}$ , No Load**



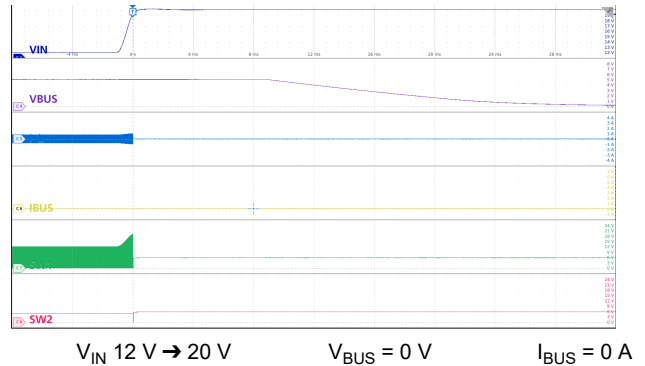
**Figure 9-26. Buck-Boost Mode: Nominal  $V_{IN}$ , 3 A Load**



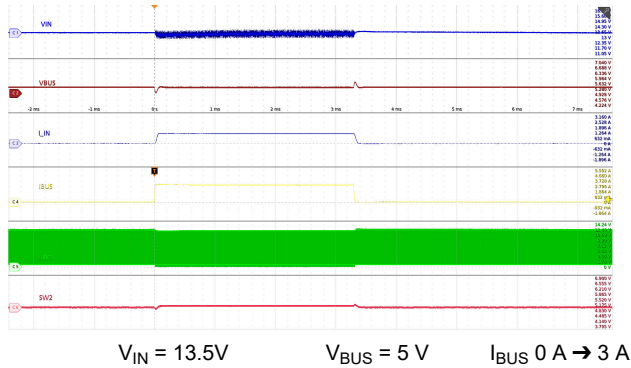
**Figure 9-27.  $V_{IN(OVP)}$  Entry**



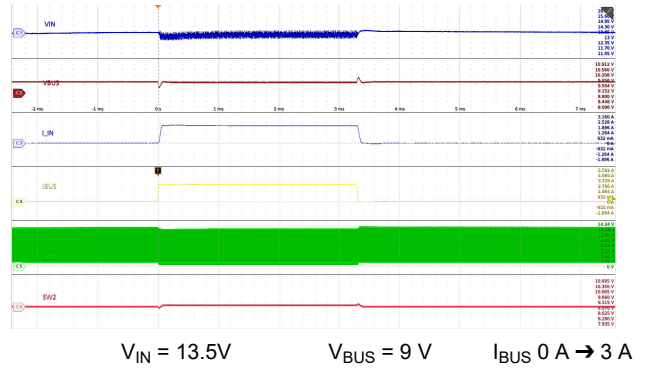
**Figure 9-28.  $V_{IN(OVP)}$  Recovery**



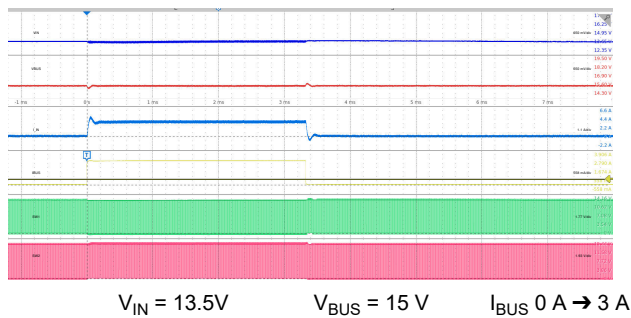
**Figure 9-29.  $V_{IN(OVP)}$  Showing  $V_{BUS}$  Discharge**



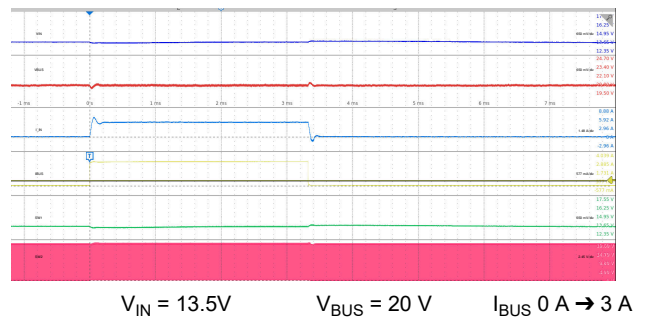
**Figure 9-30. Load Transient (Buck):  $V_{BUS} = 5\text{ V}$**



**Figure 9-31. Load Transient (Buck):  $V_{BUS} = 9\text{ V}$**



**Figure 9-32. Load Transient (Buck-Boost):  $V_{BUS} = 15\text{ V}$**



**Figure 9-33. Load Transient (Boost):  $V_{BUS} = 20\text{ V}$**

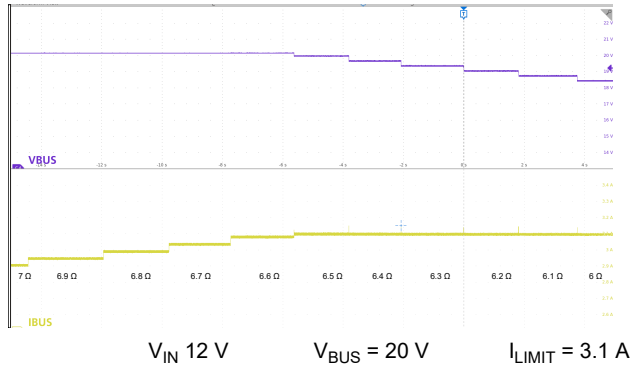


Figure 9-34. Current Limit: Stepped Resistive Load

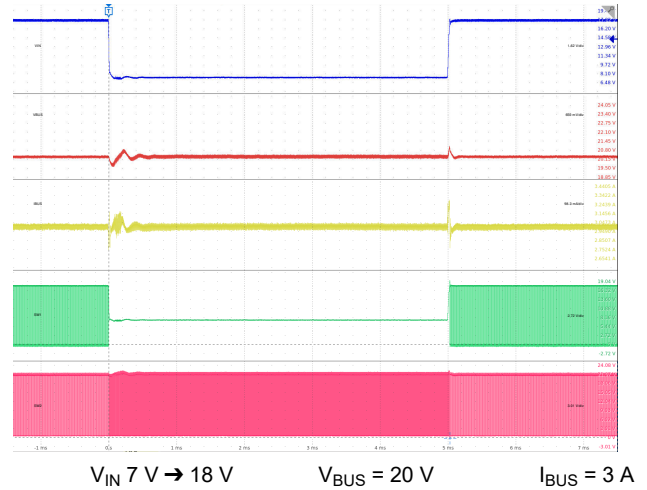


Figure 9-35. Line Transient:  $V_{BUS} = 20\text{ V}$

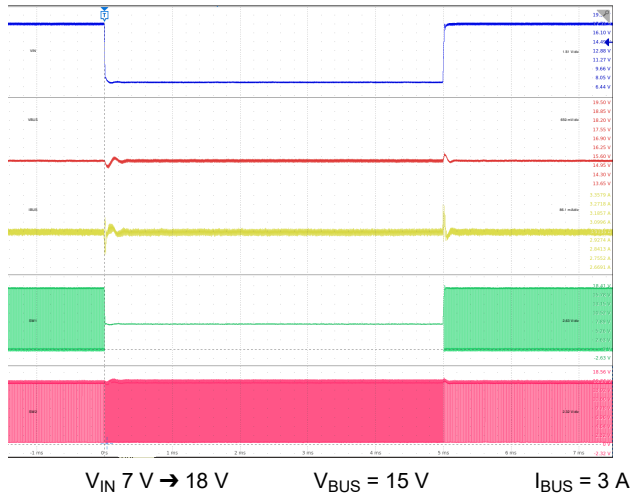


Figure 9-36. Line Transient:  $V_{BUS} = 15\text{ V}$

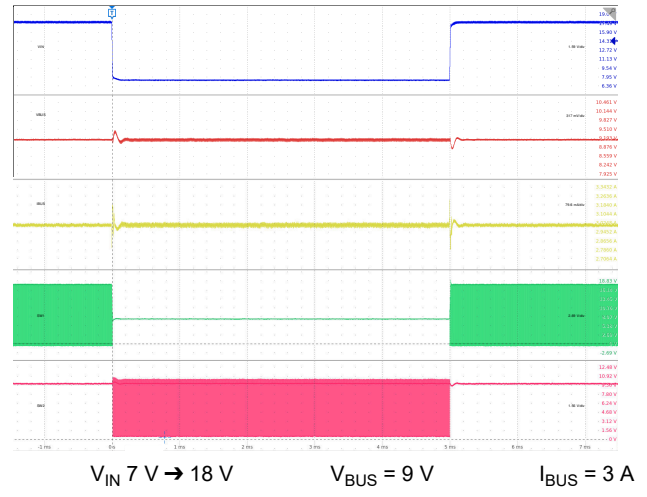


Figure 9-37. Line Transient:  $V_{BUS} = 9\text{ V}$

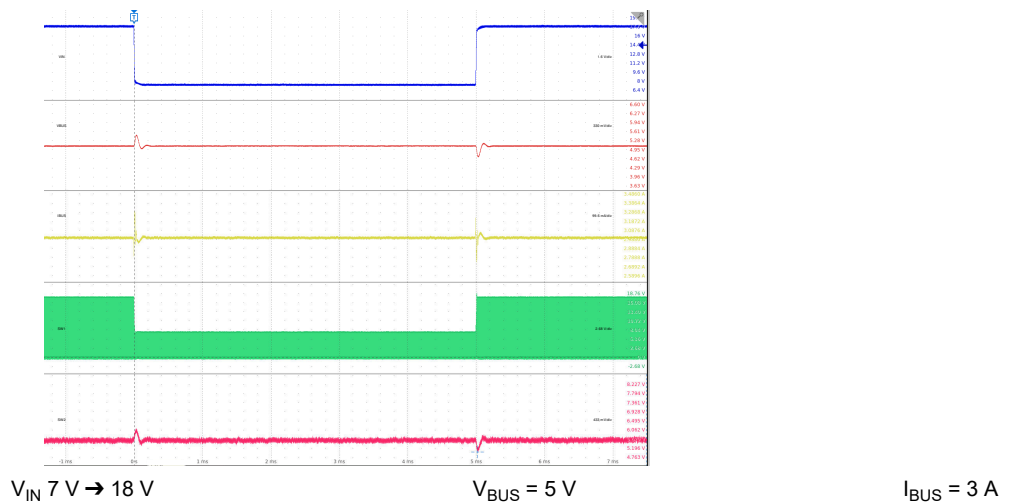


Figure 9-38. Line Transient:  $V_{BUS} = 5\text{ V}$

## 9.3 Power Supply Recommendations

The TPS25762-Q1 is a power management device typically operated from an automotive battery, though the power supply for the device can be any dc voltage source within the specified  $V_{IN}$  input range. The supply must be capable of supplying sufficient current based on the maximum inductor current in boost mode operation. The input supply can be bypassed with bulk capacitors at the input of the application board to avoid ringing due to parasitic impedance of the connecting cables. A typical choice is an aluminum electrolytic capacitor of 47 to 100  $\mu\text{F}$ .

## 9.4 Layout

### 9.4.1 Layout Guidelines

The basic PCB board layout requires separation of sensitive signal and power paths. This checklist must be followed to get good performance for a well-designed board.

- Use a combination of bulk capacitors and smaller ceramic capacitors with low series impedance for the IN, OUT, and  $V_{BUS}$  capacitors. Place the smaller capacitors closer to the IC to provide a low impedance path for high di/dt switching currents.
- Refer to [Table 9-1](#) for suggested  $C_{IN}$  values. Place the input bypass capacitors,  $C_{IN}$  and  $C_{IN\_HF}$ , as close to the IN and PGND pins as possible to minimize the loop area for input switching current in buck operation. The  $C_{IN\_HF}$  capacitors must be as close as possible - see [Figure 9-4](#). The IN and PGND pins transverse the package and it is highly recommended to split  $C_{IN}$  and  $C_{IN\_HF}$  such that capacitors can be placed on either side.
- Place the output filter capacitors,  $C_{OUT}$  and  $C_{OUT\_HF}$ , as close to the OUT and PGND pins as possible to minimize the loop area for output switching current in boost operation. Refer to [Table 9-1](#) for suggested  $C_{OUT}$  and  $C_{OUT\_HF}$  values.
- Place the current sense resistor and filter components,  $R_{SNS}$ ,  $R_{CSP}$ ,  $R_{CSN}$ , and  $C_{FLT}$ . Place the filter capacitor for the current sense signal as close to the IC CSP and CSN/BUS as possible. Use Kelvin connections between  $R_{SNS}$  through the CSP and CSN resistors and to the CSP and CSN/BUS pins to avoid creating offsets in the current sense amplifier. Avoid crossing noisy areas such as SW1 and SW2 nodes. The recommended values in [Table 9-2](#) provide a good starting point but may require some fine adjustment to meet PPS current limit accuracy requirements. When deviating from recommended values,  $R_{CSP}$  must not be larger than 10 ohms.  $R_{CSN}$  must be 0 ohms.  $C_{FLT}$  cannot be larger than 0.33  $\mu\text{F}$ .
- Place  $C_{BUS}$  between the  $R_{SNS}$  and the USB Type-C connector. See [Table 9-1](#) for suggested  $C_{BUS}$  values.
- Place the  $C_{IN}$ ,  $C_{OUT}$ , and  $C_{BUS}$  ground connections as close as possible to the IC with thick ground trace and/or planes on multiple layers.
- Minimize the SW1 and SW2 loop areas as these are high dv/dt nodes.
- Place the LDO\_5V bypass capacitors,  $C_{5V}$  and  $C_{5V\_HF}$  close to the IC pin, between the LDO\_5V and PGND pins. A 4.7  $\mu\text{F}$  and 0.1  $\mu\text{F}$  ceramic capacitors are typically used. LDO\_5V supplies LDO\_3V3 and LDO\_1V5 as well as the low side buck and boost MOSFETs.
- Place the LDO\_3V3 bypass capacitors,  $C_{3V3}$  and  $C_{3V3\_HF}$  close to the IC pin, between the LDO\_3V3 and AGND pins. A 4.7  $\mu\text{F}$  and 0.1  $\mu\text{F}$  ceramic capacitors are typically used. LDO\_3V3 supplies the analog IO circuits.
- Place the LDO\_1V5 bypass capacitors,  $C_{1V5}$  and  $C_{1V5\_HF}$  close to the IC pin, between the LDO\_1V5 and AGND pins. A 4.7  $\mu\text{F}$  and 0.1  $\mu\text{F}$  ceramic capacitors are typically used. LDO\_3V3 supplies the Cortex M0 and digital circuits.
- Place the BOOT1 bootstrap capacitor close to the IC and connect directly to the BOOT1 to SW1 pins. For EMI mitigation, a series resistor  $R_{BOOT1}$  may be added.
- Place the BOOT2 bootstrap capacitor close to the IC and connect directly to the BOOT2 to SW2 pins. For EMI mitigation, a series resistor  $R_{BOOT2}$  may be added.
- Bypass the TVSP pin to PGND with a low ESR ceramic capacitor,  $C_{TVSP}$  located close to the IC. A 0.1  $\mu\text{F}$  ceramic capacitor is typically used.  $R_{TVSP\_DAMP}$  and  $C_{TVSP\_DAMP}$  must be added in parallel close to  $C_{TVSP}$ . 10  $\Omega$  and 0.47  $\mu\text{F}$  are recommended values.
- Use care to separate the power and signal paths so that no power or switching current flows through the AGND connections which can either corrupt the USB PD modem or GPIO signals. The PGND and AGND traces can be connected near the AGND pin.

- USB data lines, DP and DM must be differentially routed between the IC pins and USB connector. Impedance control is based on the PCB stack-up.  $90\ \Omega$  differential is recommended. Route the DP and DM USB signals using a minimum of vias and corners which reduces signal reflections and impedance changes. When a via must be used, increase the clearance size around it to minimize its capacitance. Each via introduces discontinuities in the signal's transmission line and increases the chance of picking up interference from the other layers of the board. Be careful when designing test points on twisted pair lines; through-hole pins are not recommended. When it becomes necessary to turn  $90^\circ$ , use two  $45^\circ$  turns or an arc instead of making a single  $90^\circ$  turn to reduce reflections on the signal traces by minimizing impedance discontinuities. Avoid stubs on the high-speed USB signals because they cause signal reflections. If a stub is unavoidable, keep the length to less than 200 mm.
- CC lines must be routed with a 10-mil trace to ensure the needed current for supporting powered Type-C cables through VCONN. For more information on VCONN refer to the Type-C specifications. For the 330 pF CC capacitor GND pins use a 16-mil trace if possible.
- GPIO signals can be fanned out on the top or bottom layer using either a 8-mil or 10-mil trace.

### 9.4.2 Layout Example

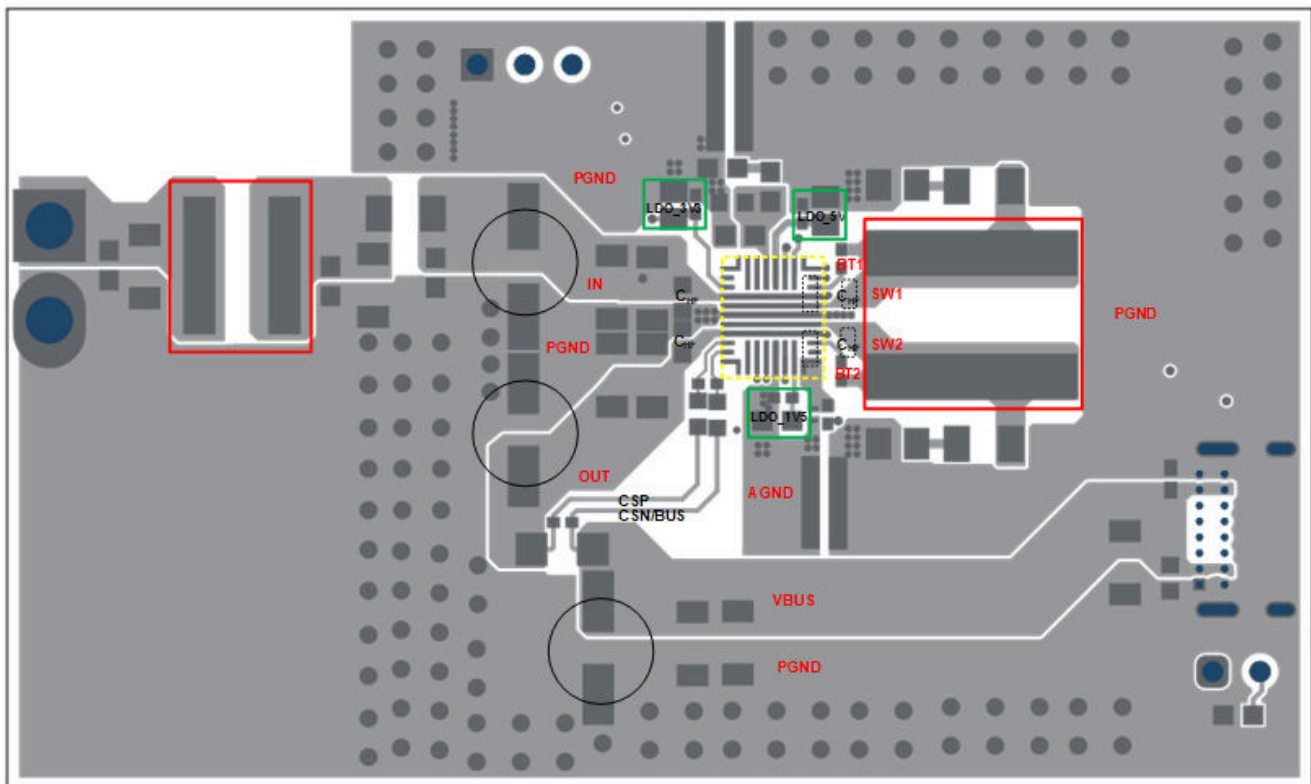


Figure 9-39. TPS25762-Q1 Power Stage Layout

## 10 Device and Documentation Support

### 10.1 Documentation Support

#### 10.1.1 Related Documentation

Please visit TI homepage for latest technical document including application notes, user guides, and reference designs.

IC Package Thermal Metrics application report, [Semiconductor and IC Package Thermal Metrics](#).

### 10.2 Receiving Notification of Documentation Updates

To receive notification of documentation updates, navigate to the device product folder on [ti.com](#). Click on *Notifications* to register and receive a weekly digest of any product information that has changed. For change details, review the revision history included in any revised document.

### 10.3 Support Resources

[TI E2E™ support forums](#) are an engineer's go-to source for fast, verified answers and design help — straight from the experts. Search existing answers or ask your own question to get the quick design help you need.

Linked content is provided "AS IS" by the respective contributors. They do not constitute TI specifications and do not necessarily reflect TI's views; see TI's [Terms of Use](#).

### 10.4 Trademarks

DisplayPort™ is a trademark of Video Electronics Standards Association (VESA).

HotRod™ and TI E2E™ are trademarks of Texas Instruments.

USB Type-C® is a registered trademark of USB Implementers Forum.

ARM® and Cortex® are registered trademarks of Arm Limited (or its subsidiaries) in the US and/or elsewhere.

All trademarks are the property of their respective owners.

### 10.5 Electrostatic Discharge Caution



This integrated circuit can be damaged by ESD. Texas Instruments recommends that all integrated circuits be handled with appropriate precautions. Failure to observe proper handling and installation procedures can cause damage.

ESD damage can range from subtle performance degradation to complete device failure. Precision integrated circuits may be more susceptible to damage because very small parametric changes could cause the device not to meet its published specifications.

### 10.6 Glossary

[TI Glossary](#) This glossary lists and explains terms, acronyms, and definitions.

## 11 Revision History

NOTE: Page numbers for previous revisions may differ from page numbers in the current version.

<b>Changes from Revision A (September 2023) to Revision B (October 2024)</b>	<b>Page</b>
• Added TPS25762DQRQLRQ1, TPS25763DQRQLRQ1 and TPS25772DQRQLRQ1 devices to Device Comparison Table.....	3
• Updated TVSP test conditions to include TPS257xxD-Q1 devices.....	16
• Updated for TPS25762DQRQLRQ1 and TPS25772DQRQLRQ1 R <sub>TVSP</sub> configuration settings; default application configuration when EEPROM boot is not available.....	35

<b>Changes from Revision * (December 2022) to Revision A (September 2023)</b>	<b>Page</b>
• Added TPS25762-Q1 and TPS25772-Q1 USB-IF certification TID.....	1
• Added wettable flank package information.....	1

---

- Added TPS25762CAQRQLRQ1, TPS25772CAQRQLRQ1, TPS25762CQRQLRQ1 and TPS25772CQRQLRQ1 devices to Device Comparison Table..... 3
- Added TPS25762CAQRQLRQ1 and TPS25772CAQRQLRQ1  $R_{TVSP}$  configuration settings..... 35
- Added  $R_{TVSP}$  Circuit Configuration for applications requiring a configuration other than TVSP Index 0 ( $R_{TVSP}$  open)..... 35

---

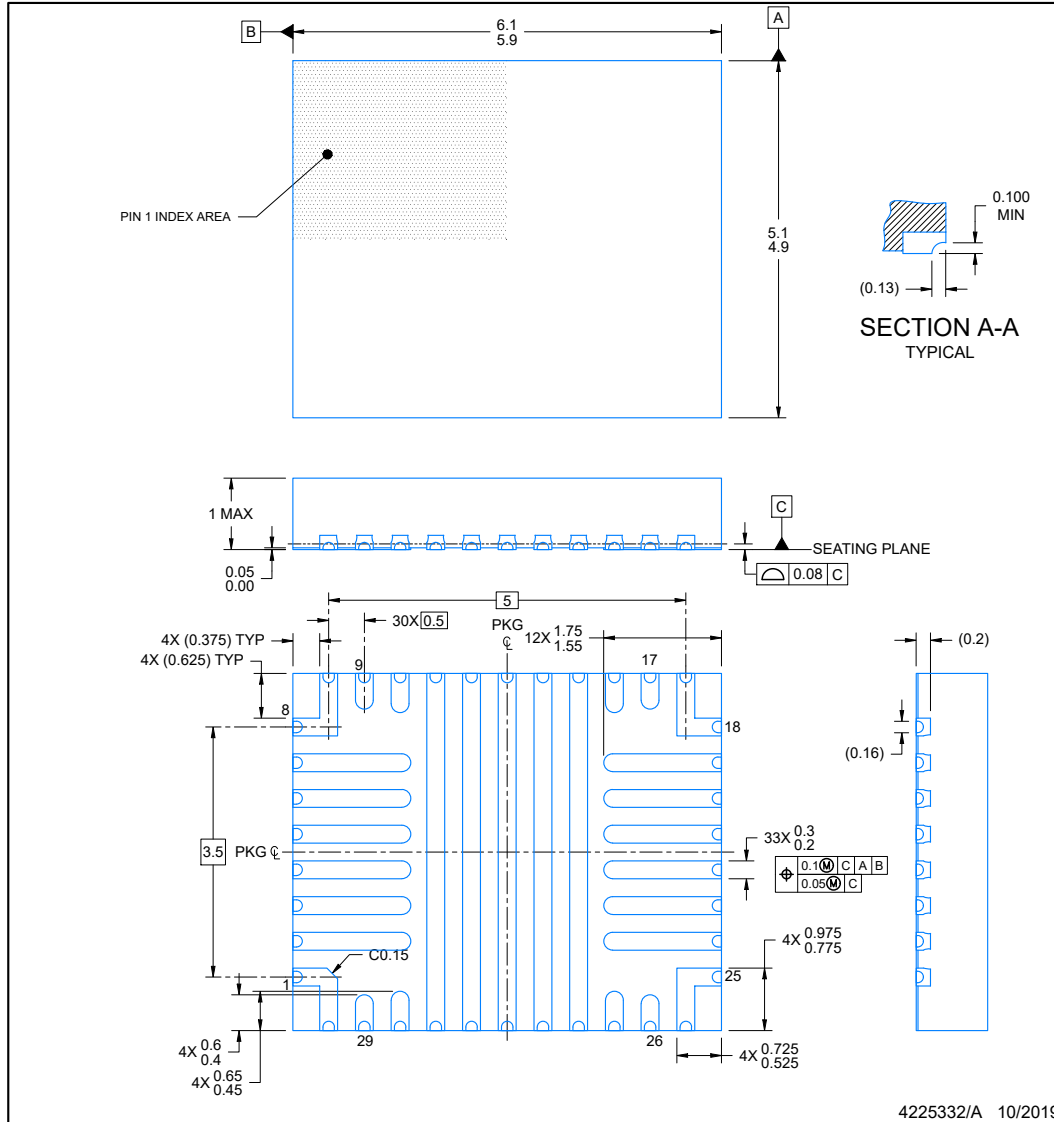
## 12 Mechanical, Packaging, and Orderable Information

The following pages include mechanical, packaging, and orderable information. This information is the most current data available for the designated devices. This data is subject to change without notice and revision of this document. For browser-based versions of this data sheet, refer to the left-hand navigation.

**RQL0029A**

**PACKAGE OUTLINE**  
**VQFN-HR - 1 mm max height**

PLASTIC QUAD FLATPACK-NO LEAD



NOTES:

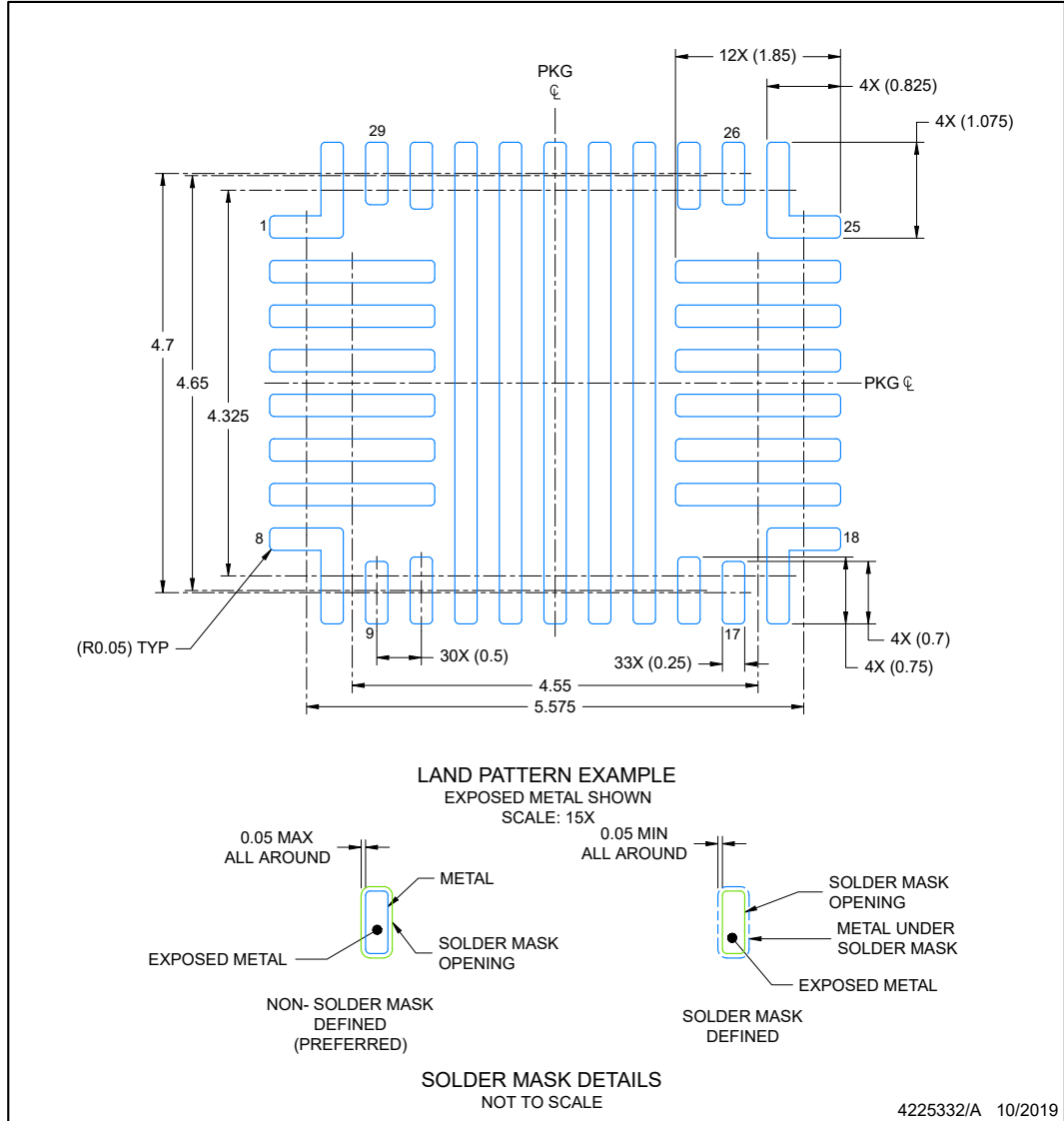
1. All linear dimensions are in millimeters. Any dimensions in parenthesis are for reference only. Dimensioning and tolerancing per ASME Y14.5M.
2. This drawing is subject to change without notice.

**EXAMPLE BOARD LAYOUT**

**RQL0029A**

**VQFN-HR - 1 mm max height**

PLASTIC QUAD FLATPACK-NO LEAD



NOTES: (continued)

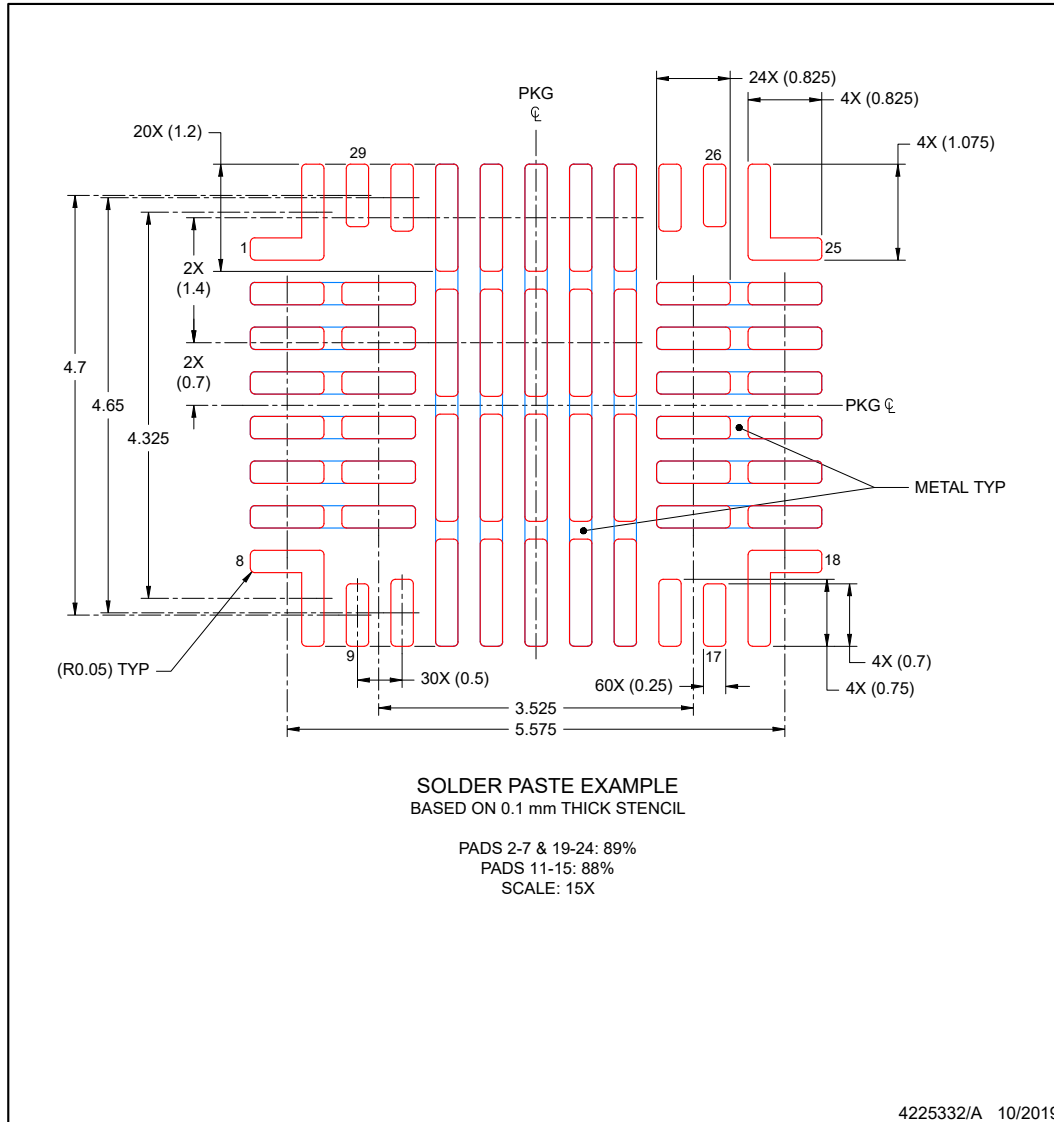
3. For more information, see Texas Instruments literature number SLUA271 ([www.ti.com/lit/slua271](http://www.ti.com/lit/slua271)).
4. Solder mask tolerances between and around signal pads can vary based on board fabrication site.

**EXAMPLE STENCIL DESIGN**

**RQL0029A**

**VQFN-HR - 1 mm max height**

PLASTIC QUAD FLATPACK-NO LEAD



NOTES: (continued)

5. Laser cutting apertures with trapezoidal walls and rounded corners may offer better paste release. IPC-7525 may have alternate design recommendations.

**PACKAGING INFORMATION**

Orderable part number	Status (1)	Material type (2)	Package   Pins	Package qty   Carrier	RoHS (3)	Lead finish/ Ball material (4)	MSL rating/ Peak reflow (5)	Op temp (°C)	Part marking (6)
<a href="#">TPS25762CAQRQLRQ1</a>	Active	Production	VQFN-HR (RQL)   29	3000   LARGE T&R	Yes	NIPDAU	Level-2-260C-1 YEAR	-40 to 125	TPS25762 CA
TPS25762CAQRQLRQ1.A	Active	Production	VQFN-HR (RQL)   29	3000   LARGE T&R	Yes	NIPDAU	Level-2-260C-1 YEAR	-40 to 125	TPS25762 CA
<a href="#">TPS25762CQRQLRQ1</a>	Active	Production	VQFN-HR (RQL)   29	3000   LARGE T&R	Yes	NIPDAU	Level-2-260C-1 YEAR	-40 to 125	TPS25762 C
TPS25762CQRQLRQ1.A	Active	Production	VQFN-HR (RQL)   29	3000   LARGE T&R	Yes	NIPDAU	Level-2-260C-1 YEAR	-40 to 125	TPS25762 C
<a href="#">TPS25762DQRQLRQ1</a>	Active	Production	VQFN-HR (RQL)   29	3000   LARGE T&R	Yes	NIPDAU	Level-2-260C-1 YEAR	-40 to 125	T25762 D
TPS25762DQRQLRQ1.A	Active	Production	VQFN-HR (RQL)   29	3000   LARGE T&R	Yes	NIPDAU	Level-2-260C-1 YEAR	-40 to 125	T25762 D

(1) **Status:** For more details on status, see our [product life cycle](#).

(2) **Material type:** When designated, preproduction parts are prototypes/experimental devices, and are not yet approved or released for full production. Testing and final process, including without limitation quality assurance, reliability performance testing, and/or process qualification, may not yet be complete, and this item is subject to further changes or possible discontinuation. If available for ordering, purchases will be subject to an additional waiver at checkout, and are intended for early internal evaluation purposes only. These items are sold without warranties of any kind.

(3) **RoHS values:** Yes, No, RoHS Exempt. See the [TI RoHS Statement](#) for additional information and value definition.

(4) **Lead finish/Ball material:** Parts may have multiple material finish options. Finish options are separated by a vertical ruled line. Lead finish/Ball material values may wrap to two lines if the finish value exceeds the maximum column width.

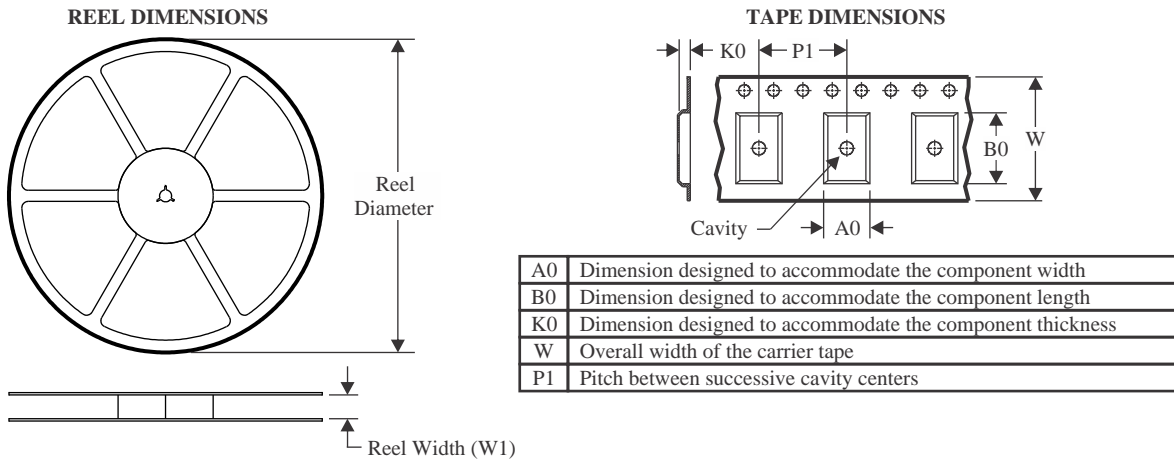
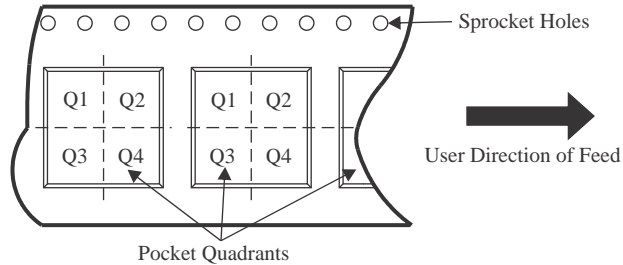
(5) **MSL rating/Peak reflow:** The moisture sensitivity level ratings and peak solder (reflow) temperatures. In the event that a part has multiple moisture sensitivity ratings, only the lowest level per JEDEC standards is shown. Refer to the shipping label for the actual reflow temperature that will be used to mount the part to the printed circuit board.

(6) **Part marking:** There may be an additional marking, which relates to the logo, the lot trace code information, or the environmental category of the part.

Multiple part markings will be inside parentheses. Only one part marking contained in parentheses and separated by a "~" will appear on a part. If a line is indented then it is a continuation of the previous line and the two combined represent the entire part marking for that device.

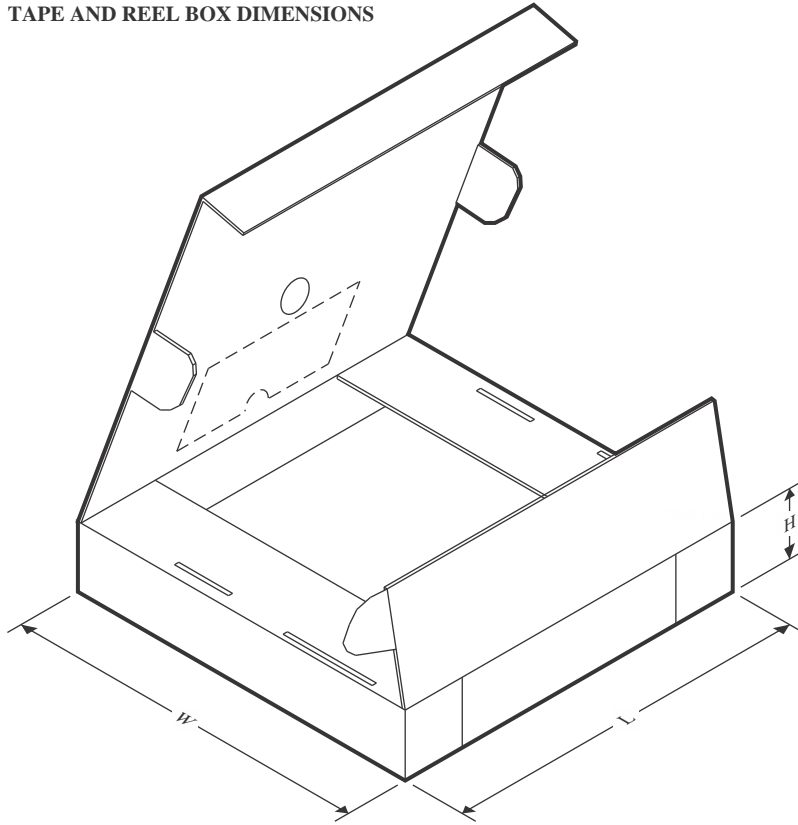
**Important Information and Disclaimer:** The information provided on this page represents TI's knowledge and belief as of the date that it is provided. TI bases its knowledge and belief on information provided by third parties, and makes no representation or warranty as to the accuracy of such information. Efforts are underway to better integrate information from third parties. TI has taken and continues to take reasonable steps to provide representative and accurate information but may not have conducted destructive testing or chemical analysis on incoming materials and chemicals. TI and TI suppliers consider certain information to be proprietary, and thus CAS numbers and other limited information may not be available for release.

In no event shall TI's liability arising out of such information exceed the total purchase price of the TI part(s) at issue in this document sold by TI to Customer on an annual basis.

**TAPE AND REEL INFORMATION**

**QUADRANT ASSIGNMENTS FOR PIN 1 ORIENTATION IN TAPE**


\*All dimensions are nominal

Device	Package Type	Package Drawing	Pins	SPQ	Reel Diameter (mm)	Reel Width W1 (mm)	A0 (mm)	B0 (mm)	K0 (mm)	P1 (mm)	W (mm)	Pin1 Quadrant
TPS25762CAQRQLRQ1	VQFN-HR	RQL	29	3000	330.0	12.4	5.3	6.3	1.15	8.0	12.0	Q2
TPS25762CQRQLRQ1	VQFN-HR	RQL	29	3000	330.0	12.4	5.3	6.3	1.15	8.0	12.0	Q2
TPS25762DQRQLRQ1	VQFN-HR	RQL	29	3000	330.0	12.4	5.3	6.3	1.15	8.0	12.0	Q2

**TAPE AND REEL BOX DIMENSIONS**


\*All dimensions are nominal

Device	Package Type	Package Drawing	Pins	SPQ	Length (mm)	Width (mm)	Height (mm)
TPS25762CAQRQRQ1	VQFN-HR	RQL	29	3000	367.0	367.0	35.0
TPS25762CQRQRQ1	VQFN-HR	RQL	29	3000	367.0	367.0	35.0
TPS25762DQRQRQ1	VQFN-HR	RQL	29	3000	367.0	367.0	35.0

## IMPORTANT NOTICE AND DISCLAIMER

TI PROVIDES TECHNICAL AND RELIABILITY DATA (INCLUDING DATASHEETS), DESIGN RESOURCES (INCLUDING REFERENCE DESIGNS), APPLICATION OR OTHER DESIGN ADVICE, WEB TOOLS, SAFETY INFORMATION, AND OTHER RESOURCES "AS IS" AND WITH ALL FAULTS, AND DISCLAIMS ALL WARRANTIES, EXPRESS AND IMPLIED, INCLUDING WITHOUT LIMITATION ANY IMPLIED WARRANTIES OF MERCHANTABILITY, FITNESS FOR A PARTICULAR PURPOSE OR NON-INFRINGEMENT OF THIRD PARTY INTELLECTUAL PROPERTY RIGHTS.

These resources are intended for skilled developers designing with TI products. You are solely responsible for (1) selecting the appropriate TI products for your application, (2) designing, validating and testing your application, and (3) ensuring your application meets applicable standards, and any other safety, security, regulatory or other requirements.

These resources are subject to change without notice. TI grants you permission to use these resources only for development of an application that uses the TI products described in the resource. Other reproduction and display of these resources is prohibited. No license is granted to any other TI intellectual property right or to any third party intellectual property right. TI disclaims responsibility for, and you fully indemnify TI and its representatives against any claims, damages, costs, losses, and liabilities arising out of your use of these resources.

TI's products are provided subject to [TI's Terms of Sale](#), [TI's General Quality Guidelines](#), or other applicable terms available either on [ti.com](#) or provided in conjunction with such TI products. TI's provision of these resources does not expand or otherwise alter TI's applicable warranties or warranty disclaimers for TI products. Unless TI explicitly designates a product as custom or customer-specified, TI products are standard, catalog, general purpose devices.

TI objects to and rejects any additional or different terms you may propose.

Copyright © 2025, Texas Instruments Incorporated

Last updated 10/2025

## Looking for pricing, stock, or lifecycle information?

Click below to explore more details on WIN SOURCE:

 [View TPS16416DRCR on WIN SOURCE](#)

 [Texas Instruments](#) Information

## Optimize Your Supply Chain with WIN SOURCE Solutions

-  Global Sourcing Solution
-  Obsolete Management
-  Cost Control Management
-  Shortage Management
-  Alternative Solution
-  Excess Inventory Management