



**THE DATASHEET OF
TPD1E05U06DYAR**



TMC6200 DATASHEET

Universal high voltage BLDC/PMSM/Servo MOSFET 3-halfbridge gate-driver with in-line motor current sensing. External MOSFETs for up to 100A motor current.

+



+

+

+

APPLICATIONS

PMSM FOC drives and BLDC motors
 Industrial Drives
 Factory Automation
 Lab Automation
 Robotics
 CNC machines
 Textile Machines
 Pumps
 Surveillance Cameras
 Home Automation
 Printers

FEATURES AND BENEFITS

3-phase motors up to 100A coil current (external MOSFETs)
Voltage Range 8 ... 60V DC
Gate Drive Programmable 0.5A / 1A / 1.5A
Full Protection and Diagnostics via SPI interface
3 Floating Sense Amplifiers with programmable gain (5, 10, 20)
Gate Off Drive with 1Ω (LS) / 1.3Ω (HS) safe hold off resistance
SPI & Stand-Alone operation
Charge Pump for 100% Duty Cycle operation
Optional BBM break-before-make logic for single line control
Programmable Short and Overload current threshold and retry
Programmable Control Interface with 3-line or 6-line drive
Full Protection & Diagnostics
Compact Size TQFP48 package
Double Pin Distance for safe operation at high voltage

DESCRIPTION

The TMC6200 is a high-power gate-driver for PMSM servo or BLDC motors. Using six external MOSFETs and two or three sense resistors, it integrates the full high voltage part of a PMSM drive system for 12V, 24V or 48V, including in-line current sense amplifiers with programmable amplification. It can drive a wide range of motors from Watt to Kilowatt. Software controlled drive strength allows in-system EME optimization. Programmable safety features like short detection and overtemperature thresholds together with an SPI interface for diagnostics allow robust and reliable designs. With the TMC6200, a minimum number of external components is required to build a rugged drive with full protection and diagnostics.

BLOCK DIAGRAM

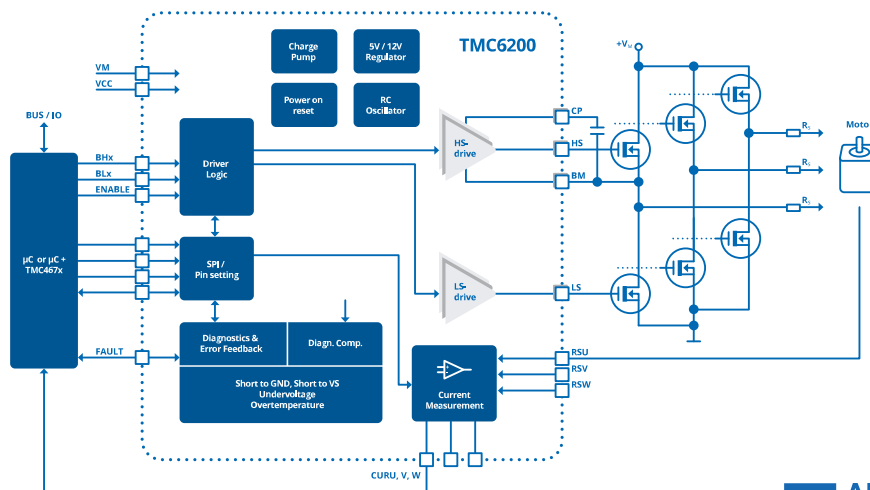

APPLICATION EXAMPLES: PMSM AND BLDC MOTORS

The TMC6200 scores with integration of the complete high-voltage part for FOC controlled PMSM drivers. On the control side, it mates with sophisticated FOC TMC467x and TMC867x family controller chips, or with any microcontroller. Its versatile interface matches simple BLDC drives with minimum requirements on the μC PWM, as well as advanced PMSM control algorithms. The small form factor and easy-to-use package of the TMC6200 keeps costs down and allows for miniaturized layouts. Extensive support at the chip, board, and software levels enables rapid design cycles and fast time-to-market with competitive products. High integration and reliability deliver cost savings in related systems such as power supplies and cooling.

MINIATURIZED CPU BASED DESIGN FOR BLDC OR PMSM

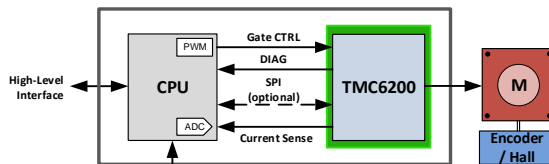

A CPU with internal BLDC or sine wave PWM unit drives the gate control lines based on encoder or hall sensor feedback. The current sensor outputs become sampled by the μC integrated ADC. Use of SPI is not required unless more sophisticated diagnostics is desired.

HIGH PERFORMANCE FOC SERVO DESIGN FOR PMSM

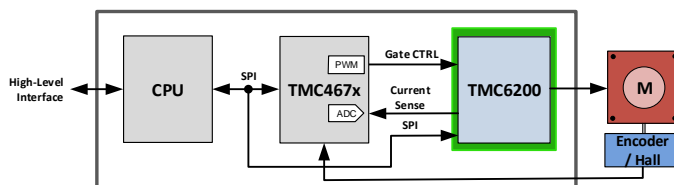

When using one of the TRINAMIC FOC controllers, the CPU is completely offloaded from time-intensive regulation loop tasks, and software design shrinks to initialization and target parameter setting. The TMC6200 optimally complements a TMC467x family controller.

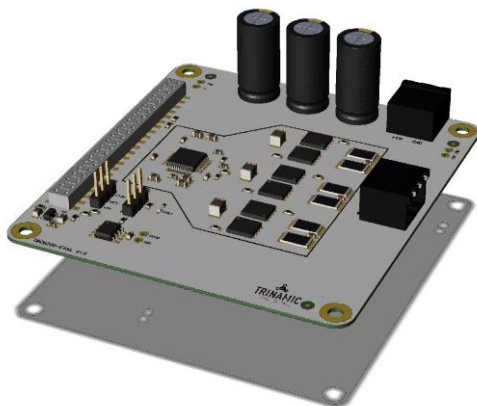

The TMC6200-EVAL is part of TRINAMIC's universal evaluation board system which provides a convenient handling of the hardware as well as a user-friendly software tool for evaluation. The TMC6200 evaluation board system consists of three parts: LANDUNGSBRÜCKE (base board), ESELSBRÜCKE (connector board including several test points), and TMC6200-EVAL, plus a TMC4671-EVAL FOC controller.

ORDER CODES

Order code	Description	Size [mm ²]
TMC6200-TA	Gate driver IC for 3 half bridges, optimized for BLDC, SPI, 8-60V, TQFP48, Tray	7 x 7 (body)
TMC6200-TA-T	Gate driver IC for 3 half bridges, optimized for BLDC, SPI, 8-60V, TQFP48, Tape & Reel	7 x 7 (body)
TMC6200-EVAL-KIT	Full Evaluation Kit for TMC6200 incl. TMC4671	197 x 85
TMC6200-EVAL	Evaluation Board for TMC6200 (excl. Landungsbrücke and Eselsbrücke)	85 x 80
TMC6200-BOB	Breakout Board with TMC6200	40 x 35

Table of Contents

1	PRINCIPLES OF OPERATION	4	8	POWER-UP RESET	34
1.1	CONTROL INTERFACES	6	9	CLOCK OSCILLATOR AND INPUT	34
2	PIN ASSIGNMENTS	7	9.1	USING THE INTERNAL CLOCK	34
2.1	PACKAGE OUTLINE	7	9.2	USING AN EXTERNAL CLOCK	34
2.2	SIGNAL DESCRIPTIONS	7	10	ABSOLUTE MAXIMUM RATINGS	35
3	SAMPLE CIRCUITS	10	11	ELECTRICAL CHARACTERISTICS	35
3.1	STANDARD APPLICATION CIRCUIT	10	11.1	OPERATIONAL RANGE	35
3.2	EXTERNAL GATE VOLTAGE REGULATOR	11	11.2	DC AND TIMING CHARACTERISTICS	36
3.3	ZERO STANDBY CURRENT	12	11.3	THERMAL CHARACTERISTICS	40
3.4	MOSFETS AND SLOPE CONTROL	13	12	LAYOUT CONSIDERATIONS	41
3.5	TUNING THE MOSFET BRIDGE	15	12.1	EXPOSED DIE PAD	41
4	SPI INTERFACE	18	12.2	WIRING GND	41
4.1	SPI DATAGRAM STRUCTURE	18	12.3	WIRING BRIDGE SUPPLY	41
4.2	SPI SIGNALS	19	12.4	SUPPLY FILTERING	41
4.3	TIMING	20	12.5	LAYOUT EXAMPLE	42
5	REGISTER MAPPING	21	13	PACKAGE MECHANICAL DATA	44
5.1	GENERAL CONFIGURATION REGISTERS	22	13.1	DIMENSIONAL DRAWINGS TQFP48-EP	44
6	CURRENT SENSE AMPLIFIERS	27	13.2	PACKAGE CODES	45
6.1	SETTLING TIME	27	14	DISCLAIMER	46
6.2	CURRENT AMPLIFIER OFFSET	28	15	ESD SENSITIVE DEVICE	46
6.3	CHOICE OF SENSE RESISTORS	31	16	DESIGNED FOR SUSTAINABILITY	46
7	DIAGNOSTICS AND PROTECTION	32	17	TABLE OF FIGURES	47
7.1	TEMPERATURE SENSORS	32	18	REVISION HISTORY	47
7.2	SHORT PROTECTION	32			

1.1 Control Interfaces

The TMC6200 supports six control lines for the MOSFET drivers. High-side and low-side outputs can be individually controlled, or by an individual enable pin plus polarity pin, using internal BBM circuitry. An SPI interface or standalone configuration is supported.

1.1.1 Standalone Configuration

Standalone configuration covers the most important settings like driver current and current amplifier amplification factor and the selection of internal or external BBM operation using four pins. Additional settings like BBM time and sensitivity of short detection can be modified using pre-programming via OTP memory, e.g., via an initial programming during product testing. This way, the driver can be fully operated, and all protection mechanisms are in place. The fault output signals any critical driver error. It becomes cleared by disabling / re-enabling the driver.

However, no advanced debugging is possible, like individual testing of failure mechanisms or setting a more sensitive temperature threshold. Also, it is not possible to switch to 20x current amplifier amplification.

Hint

Standalone configuration is recommended for low-cost applications with small motors (e.g., motor current up to 10A RMS), where advanced debugging is not required or not possible. In case a sensitive overtemperature threshold must be set, or 20x current amplifier amplification is required due to high motor current, the SPI interface should be used.

1.1.2 SPI Interface

The SPI interface is a bit-serial interface synchronous to a bus clock. For every bit sent from the bus master to the bus slave another bit is sent simultaneously from the slave to the master. Communication between an SPI master and the TMC6200 slave always consists of sending one 40-bit command word and receiving one 40-bit status word.

The SPI command rate typically is a few commands for initialization or for diagnostic feedback.

Attention

When operating in SPI mode, set drive mode (single line or individual control signals) first. For safety reasons, the driver starts up in single line mode. Note, that this setting will prevent operation if a controller operates the IC using individual control signals. Current amplifier amplification can be set within the same write access.

2 Pin Assignments

2.1 Package Outline

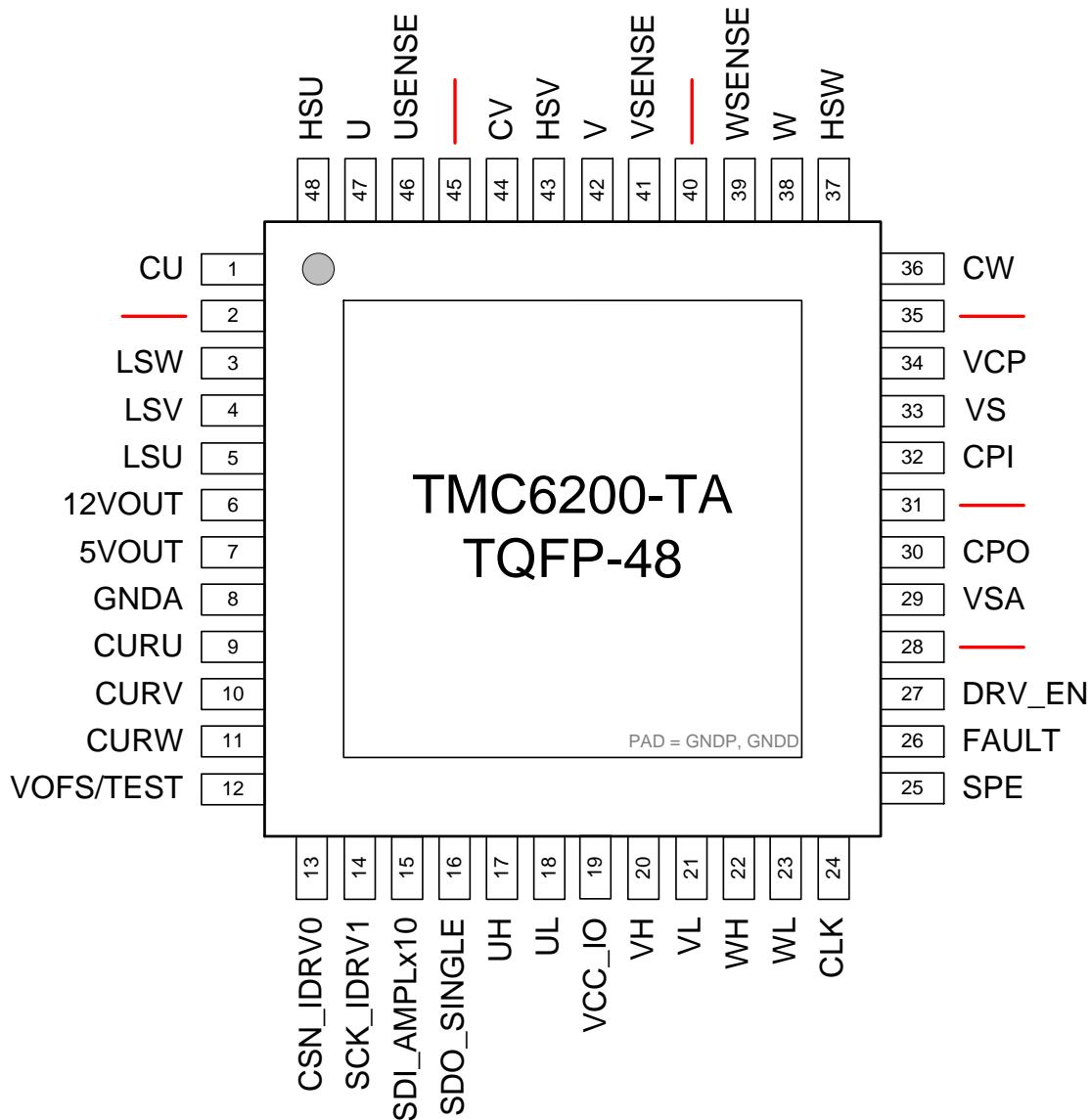

Figure 2.1 TMC6200-TA pinning TQFP-EP 48 (7x7mm² body, 9x9mm² with leads)

2.2 Signal Descriptions

Pin	TQFP	Type	Function
CU	1		Bootstrap capacitor positive connection. Tie to U terminal using 470nF to 1µF, 16V or 25V ceramic capacitor.
-	2, 28, 31, 35, 40, 45	N.C.	Unused pins for increased creeping distances.
LSW	3		Low side gate driver output.
LSV	4		Low side gate driver output.

Pin	TQFP	Type	Function
LSU	5		Low side gate driver output.
12VOUT	6		Output of internal 11.5V gate voltage regulator and supply pin of low side gate drivers. Attach 2.2 μ F to 22 μ F ceramic capacitor to GND plane near to pin for best performance. Use at least 5-10 times more capacity than for bootstrap capacitors. In case an external gate voltage supply is available, tie VSA and 12VOUT to the external supply.
5VOUT	7		Output of internal 5V regulator. Attach 2.2 μ F to 10 μ F ceramic capacitor to GNDA near to pin for best performance.
GNDA	8		Analog GND. Connect to GND plane near pin.
CURU	9	AO	Output of current sense amplifier.
CURV	10	AO	Output of current sense amplifier.
CURW	11	AO	Output of current sense amplifier.
VOFS/TEST	12	AI	Center reference for current sense amplifiers (leave open for 5VOUT/3 offset voltage).
CSN_IDRV0	13	DI	SPI chip select input (negative active) (SPE=1) or Configuration input for gate driver current LSB (SPE=0)
SCK_IDRV1	14	DI	SPI serial clock input (SPE=1) or Configuration input for gate driver current MSB (SPE=0)
SDI_AMPLx10	15	DI	SPI data input (SPE=1) or Configuration input for current sense amplifier 5x or 10x amplification (SPE=0)
SDO_SINGLE	16	DIO	SPI data output (tristate) (SPE=1) or Configuration input for internal bridge control mode (0: dual line, 1: xH=phase polarity, xL=phase enable) (SPE=0)
UH	17	DI (pd)	High side control input (or bridge polarity in single mode)
UL	18	DI (pd)	Low side control input (or bridge enable in single mode)
VCC_IO	19		3.3V to 5V IO supply voltage for all digital pins.
VH	20	DI (pd)	High side control input (or bridge polarity in single mode)
VL	21	DI (pd)	Low side control input (or bridge enable in single mode)
WH	22	DI (pd)	High side control input (or bridge polarity in single mode)
WL	23	DI (pd)	Low side control input (or bridge enable in single mode)
CLK	24	DI	CLK input. Tie to GND using short wire for internal clock or supply external clock. Internal clock-fail over circuit protects against loss of external clock signal.
SPE	25	DI (pd)	Mode selection input. When tied low, the chip is in standalone mode and SPI pins have their configuration pin functions. When tied high, the SPI interface is enabled. Integrated pull down resistor.
FAULT	26	DO	Diagnostics output. High upon driver error condition. Clear by cycling EN.
DRV_EN	27	DI	Positive active enable input. The power stage becomes switched off (all motor outputs floating) when this pin becomes driven to a low level. Cycle low to clear FAULT.
VSA	29		Analog supply voltage for 11.5V and 5V regulator. Normally tied to VS. Provide a 100nF filtering capacitor to GND.
CPO	30		Charge pump capacitor output.

Pin	TQFP	Type	Function
CPI	32		Charge pump capacitor input. Tie to CPO using 22nF 100V capacitor. In case ringing of the power supply leads to considerable supply ripple, add a 10-220ohm series resistor.
VS	33		Motor supply voltage. Provide filtering capacity near pin with short loop to GND plane. Must be tied to the positive bridge supply voltage. Severe ringing must be avoided.
VCP	34		Charge pump voltage. Tie to VS using 100nF capacitor.
CW	36		Bootstrap capacitor positive connection. Tie to W terminal using 470nF to 1µF, 16V or 25V ceramic capacitor.
HSW	37		High side gate driver output.
W	38		Bridge center and bootstrap capacitor negative connection. Connect to source pin of HS-MOSFET.
WSENSE	39	AI	Sense resistor connection for phase W. Connect to the motor side of the sense resistor. A 10Ω to 22Ω protection resistor is recommended. Directly connect to W, in case no sense resistor is used.
VSENSE	41	AI	Sense resistor connection for phase V. Connect to the motor side of the sense resistor. A 10Ω to 22Ω protection resistor is recommended. Directly connect to V, in case no sense resistor is used.
V	42		Bridge center and bootstrap capacitor negative connection. Connect to source pin of HS-MOSFET.
HSV	43		High side gate driver output.
CV	44		Bootstrap capacitor positive connection. Tie to V terminal using 470nF to 1µF, 16V or 25V ceramic capacitor.
USENSE	46	AI	Sense resistor connection for phase U. Connect to the motor side of the sense resistor. A 10Ω to 22Ω protection resistor is recommended. Directly connect to U, in case no sense resistor is used.
U	47		Bridge center and bootstrap capacitor negative connection. Connect to source pin of HS-MOSFET.
HSU	48		High side gate driver output.
Exposed die pad	-		Connect the exposed die pad to a GND plane. Provide as many as possible vias for heat transfer to GND plane. Serves as GND pin for the low side gate drivers and for digital logic. Ensure low loop inductivity to sense resistor GND.

*(pd) denominates a pin with pulldown resistor

3 Sample Circuits

The following sample circuits show the required external components in different operation and supply modes. The connection of the bus interface and further digital signals are left out for clarity.

3.1 Standard Application Circuit

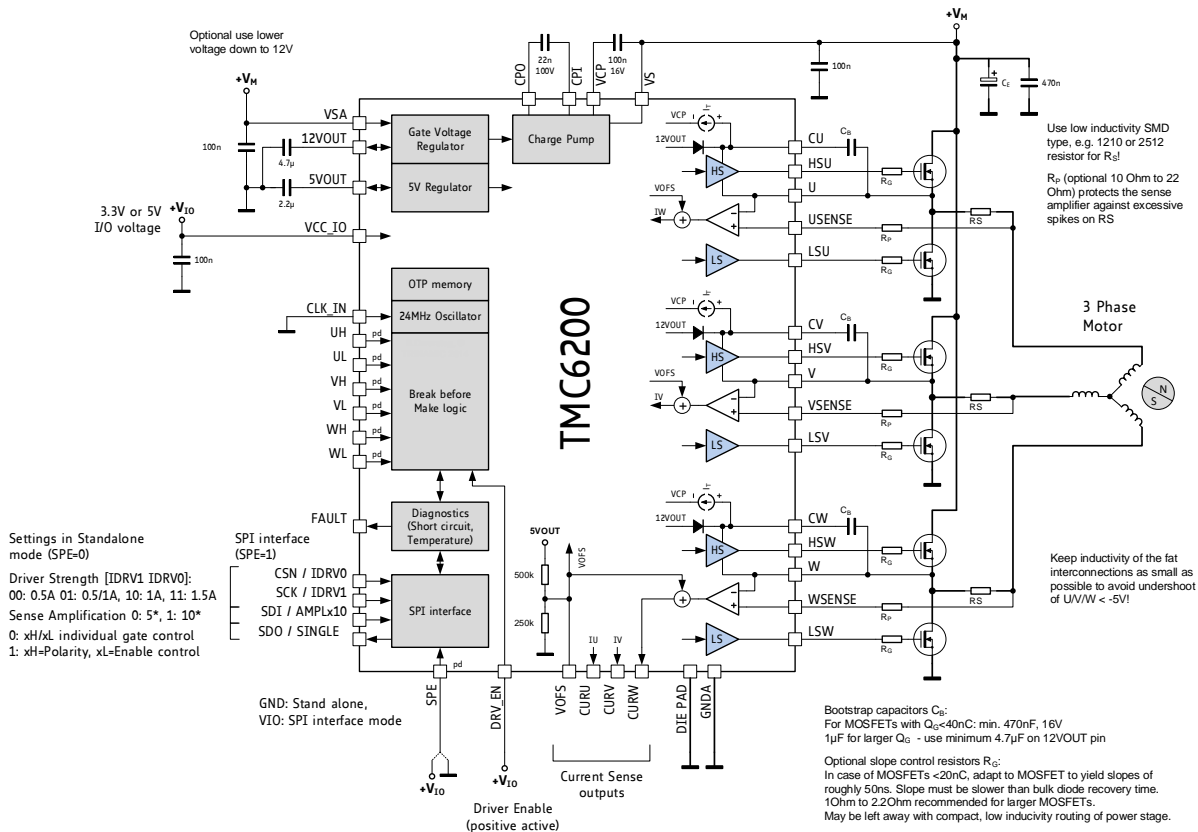

Figure 3.1 Standard application circuit

The standard application circuit uses six MOSFETs selected for the desired current, voltage and package type. Two or three sense resistors are matched to the maximum motor coil current, and to the desired current sensor output swing and amplification setting. See chapter 6.3 to choose the right value for sense resistors. Use low ESR capacitors for filtering the power supply. A minimum capacity of 100 μ F per ampere of coil current near to the power bridge is recommended for keeping power supply ripple low. The capacitors need to cope with the current ripple caused by chopper operation. Current ripple in the supply capacitors also depends on the power supply internal resistance and cable length. Supply VCC_IO from 5VOUT, or from an external source, e.g., a 3.3V regulator. To minimize linear voltage regulator power dissipation of the internal 5V and 11.5V voltage regulators in applications where VM is high, a different (lower) supply voltage should be used for VSA, when available (see chapter 3.2).

Important layout hints

Place sense resistors and all filter capacitors as close as possible to the power MOSFETs. Place the TMC6200 near to the MOSFETs and use short interconnection lines to minimize parasitic trace inductance. Use a solid common GND for all GND and GNDA connections. Connect 5VOUT filtering capacitor directly to 5VOUT and GNDA pin. See layout hints for more details. Low ESR electrolytic capacitors are recommended for VS filtering.

Hint

In safety critical applications, VS and the bridge may be supplied by a separate, switched supply to realize safe torque off. Make sure that the slope at VS slope does not exceed 1V/ μ s.

Attention

Make sure, that VCC_IO does not drop out during operation of the motor. Disable the drive when a falling supply voltage is detected. It is safest to use the same source for VCC_IO as for the controller driving the motor.

Attention

In addition to filtering capacity near to the power bridges, provide sufficient capacity on VS located close to the VS pin and the connection of the VCP capacitor, to ensure that high-frequency ripple, caused by the switching edges of the power bridge transistors are kept well below 0.5V. Keep power slopes below $1V/\mu s$. Failure to do so could result in destructive currents via the charge pump circuit. Provide overvoltage protection in case the motor could be manually turned at a high velocity, or in case the driver could become cut off from the main supply capacitors. Significant energy can be fed back from motor coils to the power supply in the event of quick deceleration, or when the driver becomes disabled.

3.2 External Gate Voltage Regulator

At high supply voltages like 48V, the internal gate voltage regulator and the internal 5V regulator have considerable power dissipation, especially with high MOSFET gate charges or high chopper frequency. A good thermal coupling of the heat slug to the system PCB GND plane is required to dissipate heat. Still, the thermal thresholds will be lowered significantly by self-heating. To reduce power dissipation, supply an external gate driver voltage to the TMC6200. Figure 3.2 shows the required connection. The internal gate voltage regulator becomes disabled in this constellation. 12V \pm 1V is recommended for best results.

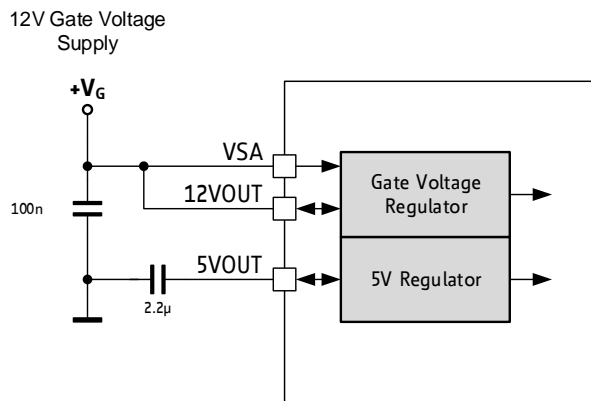

Figure 3.2 External gate voltage supply

Hint

With MOSFETs above 50nC of total gate charge or chopper frequency $>40kHz$, it is recommended to use a VSA supply not higher than 40V to keep reasonable power dissipation.

Attention

In case VSA is supplied by a different voltage source, make sure that VSA does not drop out during motor operation. The motor driver should be disabled in case VSA becomes switched off before VS. Hard switching edges on VSA might result in bridge cross-conduction otherwise. It is safest to derive VSA voltage from VS supply.

3.3 Zero Standby Current

Battery powered applications often require low current standby, while keeping the supply switched on. The TMC6200 can support these applications by completely powering down the control side, VSA, and with this also the charge pump and 5V supply. See Figure 3.3 for an example using a P-MOSFET as high-side switch. Gate charge / discharge is limited to avoid too steep slopes and excess current. VCC_IO may remain active during standby operation. Make sure that the motor becomes disabled before switching off the power supply!

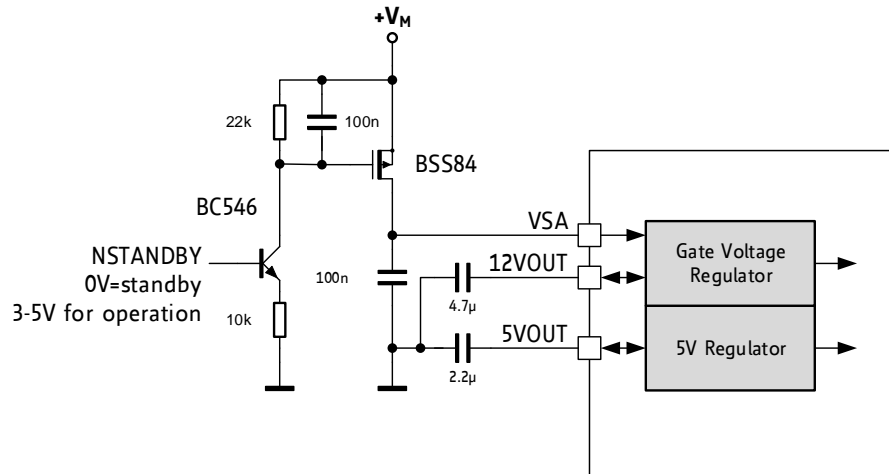

Figure 3.3 Standby Switch

Hint

Realize zero standby current by switching off VSA in standby mode. VCC_IO may remain active. Ensure a slope-controlled power-up of $1V/\mu s$ or less to avoid excess current into VSA.

Attention

Test your circuit thoroughly to ensure a safe and clean power-up and standby power-up and power-down event! When powering down the control side of the MOSFET drivers, MOSFET gate-off is only ensured by high-resistive resistors within the TMC6200. This makes the circuit more susceptible to injection of charge from MOSFET drain to gate, e.g., too high supply voltage slopes. Any spurious cross-conduction could lead to destructive currents through the power MOSFETs.

3.4 MOSFETs and Slope Control

The selection of power MOSFETs depends on several factors, like package size, on-resistance, voltage rating and supplier. It is not true, that larger, lower RDSon MOSFETs will always be better, as a larger device also has higher capacitances and may add more ringing in trace inductance and power dissipation in the gate drive circuitry. Adapt the MOSFETs to the required motor voltage (adding 5-10V of reserve to the peak supply voltage) and to the desired maximum current, in a way that resistive power dissipation still is low for the chosen MOSFET package. The TMC6200 drives the MOSFET gates with roughly 10V, so normal, 10V specified types are sufficient. Logic level FETs (4.5V specified RDSon) will also work but may be more critical with regard to bridge cross-conduction due to lower $V_{GS(th)}$.

The gate-drive current and MOSFET gate resistors R_G (optional) should basically be adapted to the MOSFET gate-drain charge (Miller charge) to yield reasonable slope times. Figure 3.4 shows the influence of the Miller charge on the switching event. Figure 3.5 additionally shows the switching events in different load situations (load pulling the output up or down), and the required bridge brake-before-make time.

The following table shall serve as a thumb rule for programming the MOSFET driver current (*DRVSTRENGTH* setting) and the selection of gate resistors:

MOSFET MILLER CHARGE VS. <i>DRVSTRENGTH</i> AND R_G		
Miller Charge [nC] (typ.)	<i>DRVSTRENGTH</i> setting	Value of R_G [Ω]
<10	0 or 1	≤ 10 (recommended)
10...20	0 to 2	≤ 5 (optional)
20...80	1 to 3	≤ 2.5 (optional)
>80	3	≤ 1 (optional)

The TMC6200 provides increased gate-off drive current to avoid bridge cross-conduction induced by high dV/dt . This protection will be less efficient with gate resistors exceeding the values given in the table. For larger values of R_G , a parallel diode may be required to ensure keeping the MOSFET safely off during switching events of the opposite MOSFET.

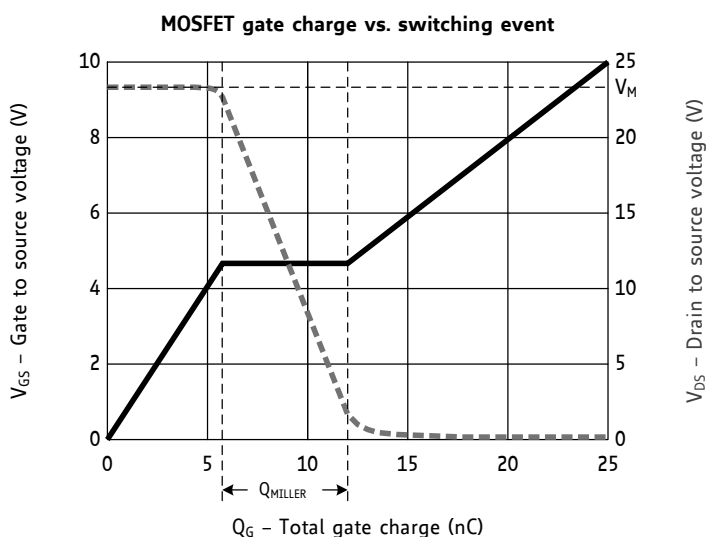

Figure 3.4 Miller charge determines switching slope

Hints

- Choose modern MOSFETs with fast and soft recovery bulk diode and low reverse recovery charge.
- A small, SMD MOSFET package allows compacter routing and reduces parasitic inductance effects.

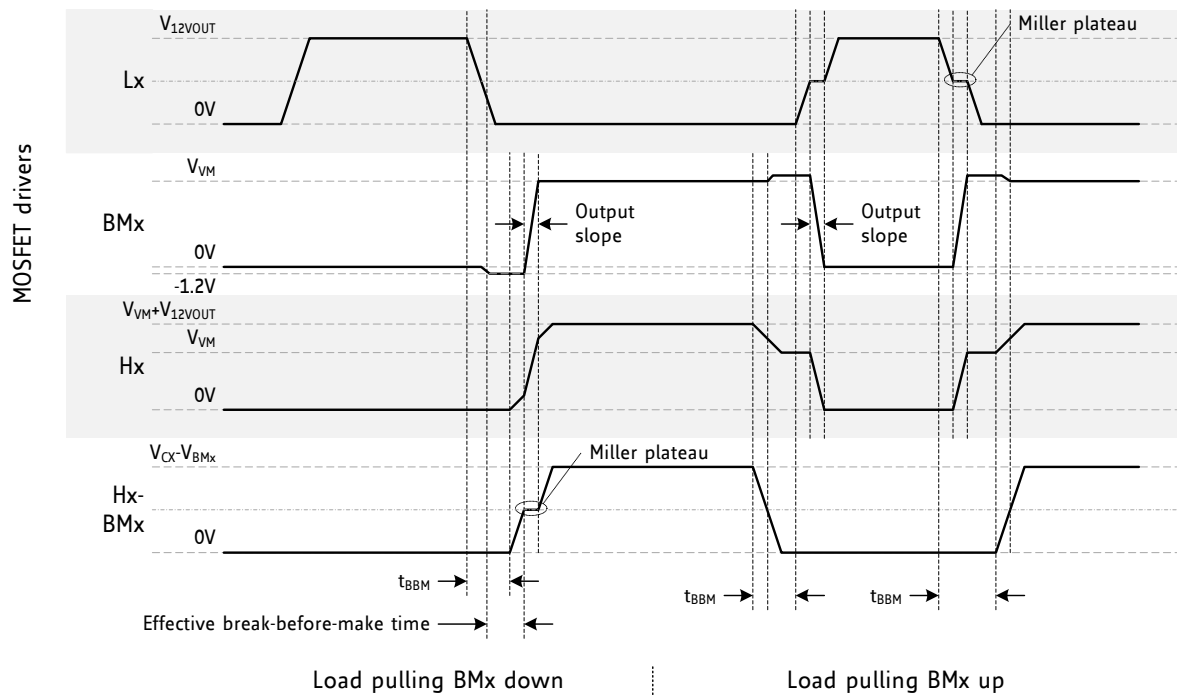

Figure 3.5 Slopes, Miller plateau and blank time (BMx=U V or W output)

The following *DRV_CONF* parameters allow adapting the driver to the MOSFET bridge:

Parameter	Description	Setting	Comment
<i>BBMCLKS</i>	Break-before-make time setting to ensure non-overlapping switching of high-side and low-side MOSFETs. Digital BBM time in clock cycles (typ. 42ns/CLK). <i>BBMCLKS</i> is used in combination with <i>singleline</i> =1. It is not applicable with individual LS and HS signals. Additionally, a minimum BBM time of 75ns is enforced by analog circuitry even with individual control signals. This prevents short-circuiting of the bridge	0...15	time[ns]≈ 42ns* <i>BBMCLKS</i> Ensure -30% headroom Reset Default: OTP 1..4 4, when not programmed
<i>DRV_STRENGTH</i>	Selection of gate driver current. Adapts the gate driver current to the gate charge of the external MOSFETs.	0...3	Reset Default = 2 in SPI mode

DRV_CONF Parameters

Use the lowest gate driver strength setting *DRV_STRENGTH* giving favorable switching slopes, before increasing the value of the gate series resistors. A slope time of nominal 40ns to 80ns is sufficient and will normally be covered by a Break-Before-Make time setting of 1 to 4 (4 is default).

In case slower slopes have to be used, e.g., with large MOSFETs, ensure that the break-before-make time sufficiently covers the switching event, in order to avoid bridge cross conduction. The shortest break-before-make time, safely covering the switching event, gives best results. Add roughly 30% of reserve, to cover production stray of MOSFETs and driver.

3.5 Tuning the MOSFET Bridge

A clean switching event is favorable to ensure low power dissipation and good EMC behavior. Unsuitable layout or components endanger stable operation of the circuit. Therefore, it is important to understand the effect of parasitic trace inductivity and MOSFET reverse recovery.

Stray inductance in power routing will cause ringing whenever the opposite MOSFET is in diode conduction prior to switching on a low-side or high-side MOSFET. Diode conduction occurs during break-before make time whenever the load current is inverse to the following bridge polarity. The MOSFET bulk diode has a certain, type specific reverse recovery time and charge. This time typically is in the range of a few 10ns. During reverse recovery time, the bulk diode will cause high current flow across the bridge. This current is taken from the power supply filter capacitors (see thick lines Figure 3.6). Once the diode opens, parasitic inductance tries to keep the current flowing. A high, fast slope results and leads to ringing in parasitic inductivities in the current path (see Figure 3.7). This may lead to bridge voltage undershooting the GND level as well as short pulses on VS and all MOSFET connections. It must be ensured, that the driver IC does not see spikes on its BM pins undershooting GND more than 5V. Severe VS ripple might overload the charge-pump circuitry. Measure the voltage directly at the driver pins to driver GND. The amount of undershooting depends on energy stored in parasitic inductivities from low side MOSFET drain to low side source GND connection.

When using relatively small MOSFETs, a soft slope control requires a high gate series resistance. This endangers safe MOSFET switch off. Add additional diodes to ensure safe MOSFET off conditions with slow switch-on slopes (Figure 3.10).

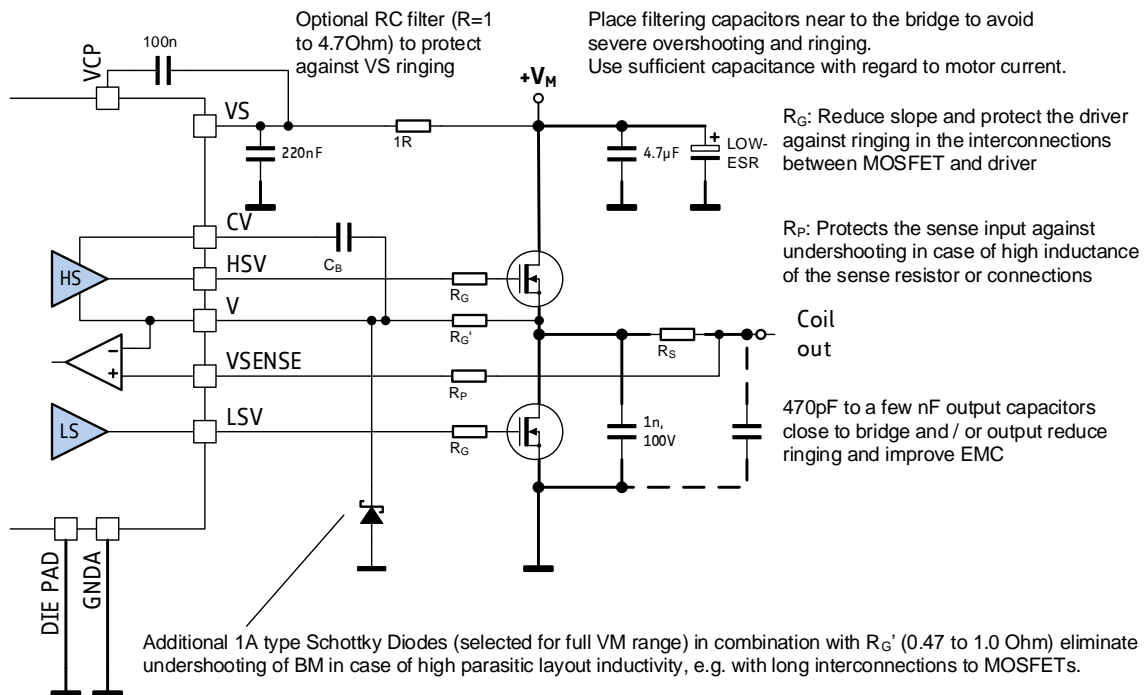

Decide use and value of the additional components based on measurements of the actual circuit using the final layout!

Figure 3.6 Bridge protection options for power routing inductivity

ENSURE RELIABLE OPERATION

- Use SMD MOSFETs and short interconnections
- Provide sufficient power filtering capacity close to the bridge and close to VS pin
- Tune MOSFET switching slopes (measure switch-on event at MOSFET gate) to be slower than the MOSFET bulk diode reverse recovery time. This will reduce cross conduction.
- Add optional gate resistors close to MOSFET gate and output capacitors to ensure clean switching and reliable operation by minimizing ringing. Figure 3.6 shows the options plus some variations.
- Some MOSFETs eliminate reverse recovery charge by integrating a fast diode from source to drain.

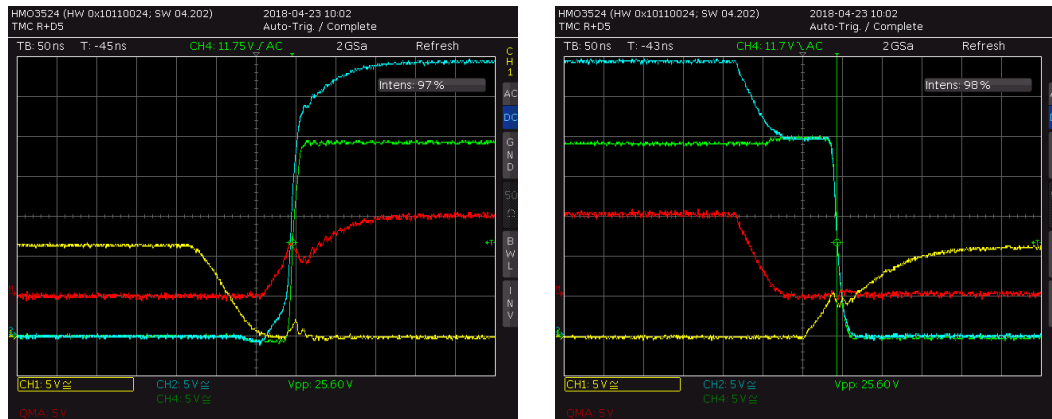

Figure 3.7 Ringing of output (green) and Gate voltages (yellow, blue) with DRVSTRENGTH=0

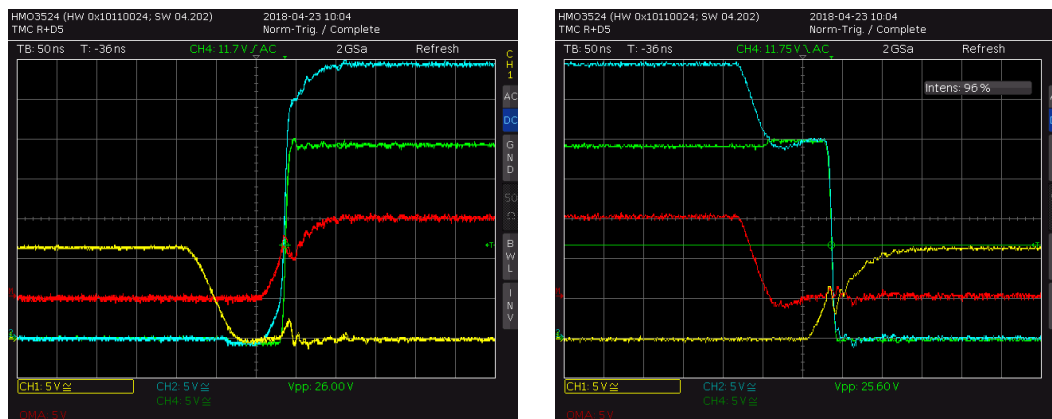

Figure 3.8 Ringing of output (green) and Gate voltages (yellow, blue) with DRVSTRENGTH=2

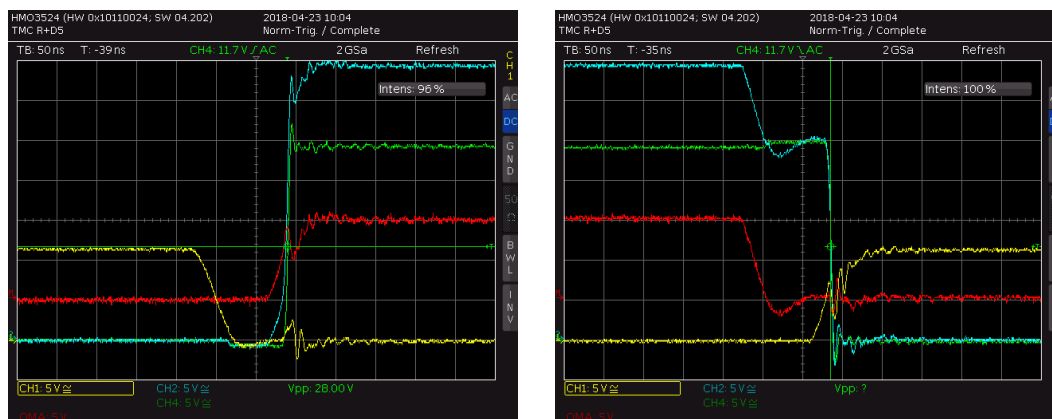

Figure 3.9 Ringing of output (green) and Gate voltages (yellow, blue) with DRVSTRENGTH=3

BRIDGE OPTIMIZATION EXAMPLE

A driver for 15A, 60V has been designed using the MOSFET BSC037N08NS ($3.7\text{m}\Omega$, 80V, $Q_G=56\text{nC}$, $t_{RR}=41\text{ns}$) in the standard schematic.

The MOSFETs offer roughly 20ns slope time at the lowest driver strength setting. Switching quality is good and signals are clean (Figure 3.7, ff.). At double drive strength, the slope time halves, and switching events still are clean. When increasing to full gate drive strength faster slopes lead to increased ringing on all signals. Low or medium slope setting is best. Additional gate resistors or 1nF output capacitors do not bring any additional improvement. The layout already proves to be good. *No additional components were required!*

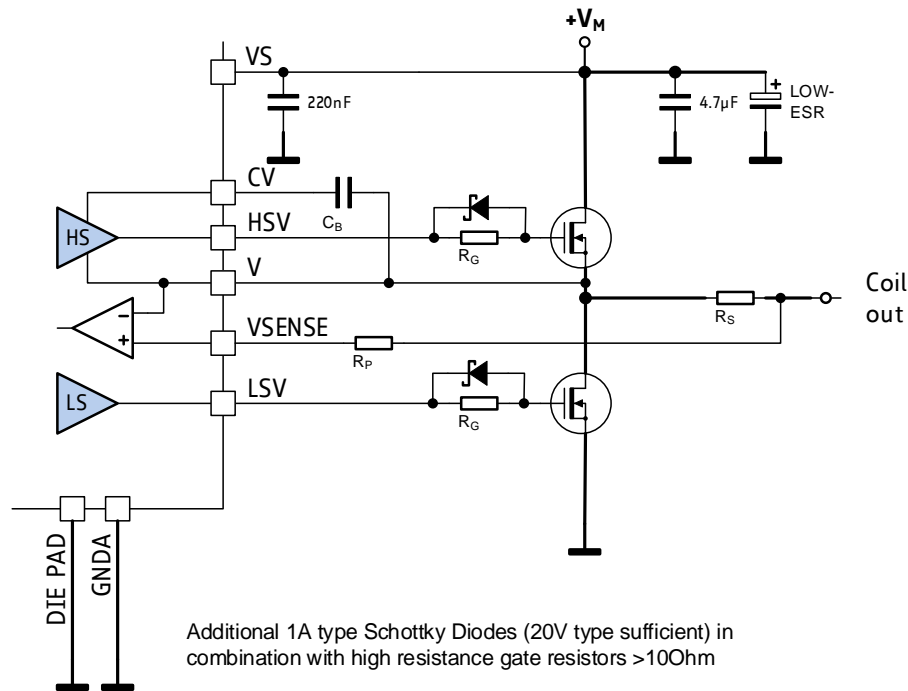

Figure 3.10 Diodes for safe off condition with high gate series resistance

BRIDGE LAYOUT CONSIDERATIONS

- Tune the bridge layout for minimum loop inductivity. A compact layout is best.
- Keep MOSFET gate connections short and straight and avoid loop inductivity between bridge feedback (U,V,W) and corresponding HS driver pin. Loop inductance is minimized with parallel traces, or adjacent traces on adjacent layers. A wider trace reduces inductivity (don't use minimum trace width).
- Place the TMC6200 near the low side MOSFETs GND connections, with its GND connections directly connected to the same GND plane.
- Optimize switching behavior by using lowest acceptable gate current setting.
- Check influence of optional components shown in Figure 3.6.
- Measure the performance of the bridge by probing BM pins directly at the bridge or at the TMC6200 using a short GND tip on the scope probe rather than a GND cable, if available.

4.1.2 Data Alignment

All data are right aligned. Some registers represent unsigned (positive) values, some represent integer values (signed) as two's complement numbers, single bits or groups of bits are represented as single bits respectively as integer groups.

4.2 SPI Signals

The SPI bus on the TMC6200 has four signals:

- SCK – bus clock input
- SDI – serial data input
- SDO – serial data output
- CSN – chip select input (active low)

The slave is enabled for an SPI transaction by a low on the chip select input CSN. Bit transfer is synchronous to the bus clock SCK, with the slave latching the data from SDI on the rising edge of SCK and driving data to SDO following the falling edge. The most significant bit is sent first. A minimum of 40 SCK clock cycles is required for a bus transaction with the TMC6200.

The TMC6200 does not allow cascading of SPI slaves. Use individual CSN lines for each device.

CSN must be low during the whole bus transaction. When CSN goes high, the contents of the internal shift register are latched into the internal control register and recognized as a command from the master to the slave.

4.3 Timing

The SPI interface is synchronized to the internal system clock, which limits the SPI bus clock SCK to 1/4 of the system clock frequency. If the system clock is based on the on-chip oscillator, an additional 10% safety margin must be used to ensure reliable data transmission. All SPI inputs as well as the ENN input are internally filtered to avoid triggering on pulses shorter than 20ns. Figure 4.1 shows the timing parameters of an SPI bus transaction, and the table below specifies their values.

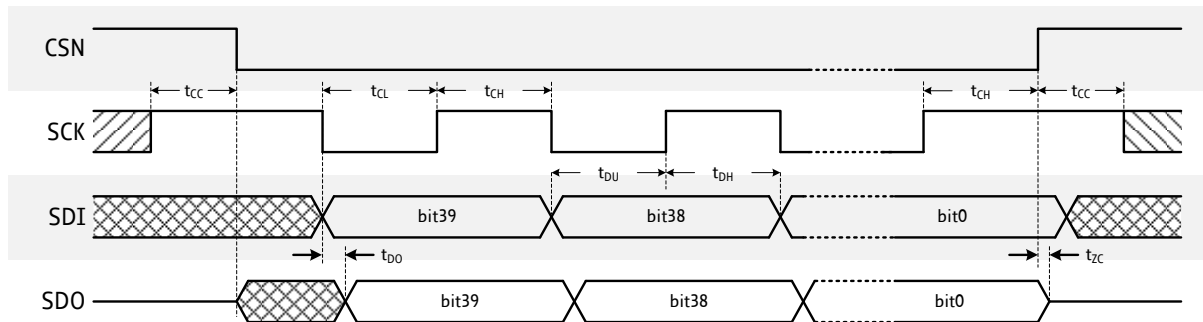

Figure 4.1 SPI timing

Hint

Usually, this SPI timing is referred to as SPI MODE 3

SPI interface timing		AC-Characteristics				
		clock period: t_{CLK}				
Parameter	Symbol	Conditions	Min	Typ	Max	Unit
SCK valid before or after change of CSN	t_{CC}		10			ns
CSN high time	t_{CSH}	*) Min time is for synchronous CLK with SCK high one t_{CH} before CSN high only	$t_{CLK}^{*)}$	$>2t_{CLK}+10$		ns
SCK low time	t_{CL}	*) Min time is for synchronous CLK only	$t_{CLK}^{*)}$	$>t_{CLK}+10$		ns
SCK high time	t_{CH}	*) Min time is for synchronous CLK only	$t_{CLK}^{*)}$	$>t_{CLK}+10$		ns
SCK frequency using internal clock	f_{SCK}	assumes minimum OSC frequency			3.5	MHz
SCK frequency using external clock	f_{SCK}	assumes synchronous CLK			$f_{CLK}/6$	MHz
SDI setup time before rising edge of SCK	t_{DU}		10			ns
SDI hold time after rising edge of SCK	t_{DH}		10			ns
Data out valid time after falling SCK clock edge	t_{DO}	no capacitive load on SDO			$t_{CLK}+10$	ns
SDI, SCK and CSN filter delay time	t_{FILT}	rising and falling edge	12	20	30	ns

5 Register Mapping

This chapter gives an overview of the complete register set. Some of the registers bundling a number of single bits are detailed in extra tables. The functional practical application of the settings is detailed in dedicated chapters.

Note

- All registers become reset to 0 upon power up, unless otherwise noted.
- Add 0x80 to the address Addr for a write access!

NOTATION OF HEXADECIMAL AND BINARY NUMBERS

0x	precedes a hexadecimal number, e.g. 0x04
%	precedes a multi-bit binary number, e.g. %100

NOTATION OF R/W FIELD

R	Read only
W	Write only
R/W	Read- and writable register
R+WC	Clear upon write back with '1'

OVERVIEW REGISTER MAPPING

REGISTER	DESCRIPTION
General Configuration Registers	These registers contain <ul style="list-style-type: none"> - global configuration - global status flags - interface configuration - driver configuration - OTP programming

5.1 General Configuration Registers

GENERAL CONFIGURATION REGISTERS (0x00...0x0F)				
R/W	Addr	n	Register	Description / bit names
RW	0x00	8	GCONF	Bit GCONF – Global configuration flags 0 <i>disable</i> : Driver Disable 1: Disable driver (Resets of short condition)
				1 <i>singleline</i> : Interface mode (<i>reset default = 1</i>) 0: Individual signals L+H 1: H-Input is control signal, L-Input is Enable
				2 <i>faultdirect</i> 0: Fault output active when at least one bridge is shut down continuously due to overcurrent or overtemperature 1: Fault output shows each protective action of the overcurrent shutdown
				3 unused
				5:4 <i>amplification</i> : Amplification of current amplifiers 0: Current amplification: *5 1: Current amplification: *10 2: (Current amplification: *10) 3: Current amplification: *20
				6 <i>amplifier_off</i> : 0: Current sense amplifiers on 1: Amplifiers off (reduce power consumption)
				7 <i>test_mode</i> 0: Normal operation 1: Enable analog test output on pin DRV_EN. <i>BBM_CLKS[1..0]</i> selects the function of DRV_EN: 0..2: T120, DAC, VDDH <i>Attention: Not for user, set to 0 for normal operation!</i>
				31:8 unused
				R+ WC
0 <i>reset</i> 1: Indicates that the IC has been reset. All registers have been cleared to reset values. <i>Attention: DRV_EN must be high to allow clearing reset</i>				
1 <i>drv_otpw</i> 1: Indicates, that the driver temperature has exceeded overtemperature prewarning-level. No action is taken. This flag is latched.				
2 <i>drv_ot</i> 1: Indicates, that the driver has been shut down due to overtemperature. This flag can only be cleared when the temperature is below the limit again. It is latched for information. ORed to STATUS output.				
3 <i>uv_cp</i> 1: Indicates an undervoltage on the charge pump. The driver is disabled during undervoltage. This				

GENERAL CONFIGURATION REGISTERS (0x00...0x0F)				
R/W	Addr	n	Register	Description / bit names
				flag is latched for information. ORed to STATUS output.
			4	<i>shortdet_u</i> 1: U short counter has triggered at least once. ORed to STATUS output.
			5	<i>s2gu</i> 1: Short to GND detected on phase U. The driver becomes disabled until flag becomes cleared. ORed to STATUS output.
			6	<i>s2vsu</i> 1: Short to VS detected on phase U. The driver becomes disabled until flag becomes cleared. ORed to STATUS output.
			7	-
			8	<i>shortdet_v</i> 1: V short counter has triggered at least once. ORed to STATUS output.
			9	<i>s2gv</i> 1: Short to GND detected on phase V. The driver becomes disabled until flag becomes cleared. ORed to STATUS output.
			10	<i>s2vsv</i> 1: Short to VS detected on phase V. The driver becomes disabled until flag becomes cleared. ORed to STATUS output.
			11	-
			12	<i>shortdet_w</i> 1: short counter has triggered at least once. ORed to STATUS output.
			13	<i>s2gw</i> 1: Short to GND detected on phase W. The driver becomes disabled until flag becomes cleared. ORed to STATUS output.
			14	<i>s2vsw</i> 1: Short to VS detected on phase W. The driver becomes disabled until flag becomes cleared. ORed to STATUS output.
			Bit	INPUT
				Reads the state of all input pins available
			0	UL
			1	UH
			2	VL
			3	VH
			4	WL
			5	WH
			6	DRV_EN
			7	0
			8	OTPW
			9	OT136°C
			10	OT143°C
R	0x04	12 + 8	IOIN	

GENERAL CONFIGURATION REGISTERS (0x00...0x0F)				
R/W	Addr	n	Register	Description / bit names
				11 OT150°C
				31..24 <i>VERSION</i> : 0x10=first version of the IC Identical numbers mean full digital compatibility.
W	0x06		<i>OTP_PROG</i>	Bit OTP_PROGRAM – OTP programming Write access programs OTP memory (one bit at a time), Read access refreshes read data from OTP after a write
				2..0 <i>OTPBIT</i> Selection of OTP bit to be programmed to the selected byte location (n=0..7: programs bit n to a logic 1)
				5..4 <i>OTPBYTE</i> Set to 00
				15..8 <i>OTPMAGIC</i> Set to 0xbd to enable programming. A programming time of minimum 10ms per bit is recommended (check by reading <i>OTP_READ</i>).
R	0x07		<i>OTP_READ</i>	Bit OTP_READ (Access to OTP memory result and update) <i>See table 5.1.1!</i>
				7..0 <i>OTPO</i> byte 0 read data
RW	0x08	5	<i>FACTORY_CONF</i>	4..0 <i>FCLKTRIM</i> (Reset default: <i>OTP</i>) 0..31: Lowest to highest clock frequency. Check at charge pump output. The frequency span is not guaranteed, but it is tested, that tuning to 12MHz internal clock is possible. The devices come preset to 12MHz clock frequency by OTP programming. (Reset Default: <i>OTP</i>)
				Bit SHORT_CONF
				3..0 <i>S2VS_LEVEL</i> : Short to VS detector level for lowside FETs. Checks for voltage drop in LS MOSFET and opt. bottom shunt. 1 (highest sensitivity) ... 15 (lowest sensitivity) (Reset Default: <i>OTP 6 or 12</i>)
				11..8 <i>S2G_LEVEL</i> : Short to GND detector level for highside FETs. Checks for voltage drop on high side MOSFET 2 (highest sensitivity) ... 15 (lowest sensitivity) <i>Hint: Use high setting. For sensitive overcurrent protection, tune S2VS level instead.</i> (Reset Default: <i>OTP 6 or 12</i>)
RW	0x09	31	<i>SHORT_CONF</i>	17..16 <i>SHORTFILTER</i> : Spike filtering bandwidth for short detection 0 (lowest, 100ns), 1 (1µs), 2 (2µs) 3 (3µs) <i>Hint: Increase value if erroneous short detection occurs.</i> (Reset Default = %01)
				20 <i>shortdelay</i> : Short detection delay 0=750ns: normal, 1=1500ns: high The short detection delay shall cover the bridge switching time. 0 will work for most applications. (Reset Default = 0)

GENERAL CONFIGURATION REGISTERS (0x00...0x0F)				
R/W	Addr	n	Register	Description / bit names
				25..24 <i>RETRY</i> : Number of retries for short detection 0: Half bridge disabled after first short detection 1..3: Half bridge re-enabled in next chopper cycles 1 time to 3 times. With retry, the short-counter is decreased once each 256 chopper cycles per coil, unless the upper limit has been reached. (Reset Default = 3)
				28 <i>protect_parallel</i> 0: Only the detected half bridge driver becomes shut down upon final short detection 1: All half bridge drivers become shut down upon final short detection (Reset Default = 1)
				29 <i>disable_S2G</i> 0: Short to GND (HS) protection enabled 1: No short to GND protection (Reset Default = 0)
				30 <i>disable_S2VS</i> 0: Short to VS (LS) protection enabled 1: No short to VS protection (Reset Default = 0)
				Bit DRV_CONF
				4..0 <i>BBMCLKS</i> : 0..15: Digital BBM time in clock cycles (typ. 42ns/CLK). <i>BBMCLKS</i> is used in combination with <i>singleline=1</i> . It is not applicable with individual LS and HS signals. (Reset Default: OTP 1..4)
				15:5 unused
				17..16 <i>OTSELECT</i> : Selection of over temperature level for bridge disable, switch on after cool down to 120°C / OTPW level. 00: 150°C (default) 01: 143°C 10: 136°C 11: 120°C (not recommended, no hysteresis) <i>Hint: Adapt overtemperature threshold as required to protect the MOSFETs or other components on the PCB.</i> (Reset Default = %00)
				19..18 <i>DRVSTRENGTH</i> : Selection of gate driver current. Adapts the gate driver current to the gate charge of the external MOSFETs. 00: weak 01: weak+TC (medium above OTPW level) 10: medium 11: strong <i>Hint: Choose the lowest setting giving slopes <100ns.</i> (Reset Default = %10)
				31:20 unused
RW	0x0A	20	DRV_CONF	

5.1.1 OTP_READ – OTP configuration memory

The OTP memory holds power up defaults for certain registers. All OTP memory bits are cleared to 0 by default. Programming only can set bits, clearing bits is not possible. Factory tuning of the clock frequency affects *otp0.0* to *otp0.4*. The state of these bits therefore may differ between individual ICs.

0x05: OTP_READ – OTP MEMORY MAP			
Bit	Name	Function	Comment
7	<i>otp0.7</i>	<i>otp_BBM</i>	Reset default for <i>BBM</i> 0: 4 clocks 1: 1 clocks 2: 2 clocks 3: 3 clocks
6	<i>otp0.6</i>		
5	<i>otp0.5</i>	<i>otp_S2_LEVEL</i>	Reset default for <i>Short detection Levels</i> : 0: <i>S2G_LEVEL</i> = <i>S2VS_LEVEL</i> = 6 1: <i>S2G_LEVEL</i> = <i>S2VS_LEVEL</i> = 12
4	<i>otp0.4</i>	<i>OTP_FCLKTRIM</i>	Reset default for <i>FCLKTRIM</i> 0: lowest frequency setting 31: highest frequency setting <i>Attention: This value is pre-programmed by factory clock trimming to the default clock frequency of 24MHz and differs between individual ICs! It should not be altered.</i>
3	<i>otp0.3</i>		
2	<i>otp0.2</i>		
1	<i>otp0.1</i>		
0	<i>otp0.0</i>		

6 Current Sense Amplifiers

Integrated current sense amplifiers allow closed loop current regulation, as required for FOC control. Measurement in series with the coil by principle is optimum for signal availability because the current will always pass the measurement shunt, independent of the actual chopper duty cycle and independent of chopper phase. While this is a great benefit against foot point measurement, a series measurement current amplifier is a complex component and may add considerable cost to a circuit. With three current amplifiers integrated into the driver, overhead is kept minimum, and series shunt sensing is available for the cost of bottom shunt measurement.

The sense amplifiers allow amplification of a bi-directional input voltage, by using an internally generated or external offset voltage (see Figure 6.1). A positive voltage difference between the related sense input and the phase output leads to the measurement output rising above VOFS. A negative difference leads to the output falling below VOFS. The programmable gain allows adaptation to the sense resistor and motor current, to optimally use the output swing and with this the input voltage range of the external ADC tied to the sense amplifier outputs.

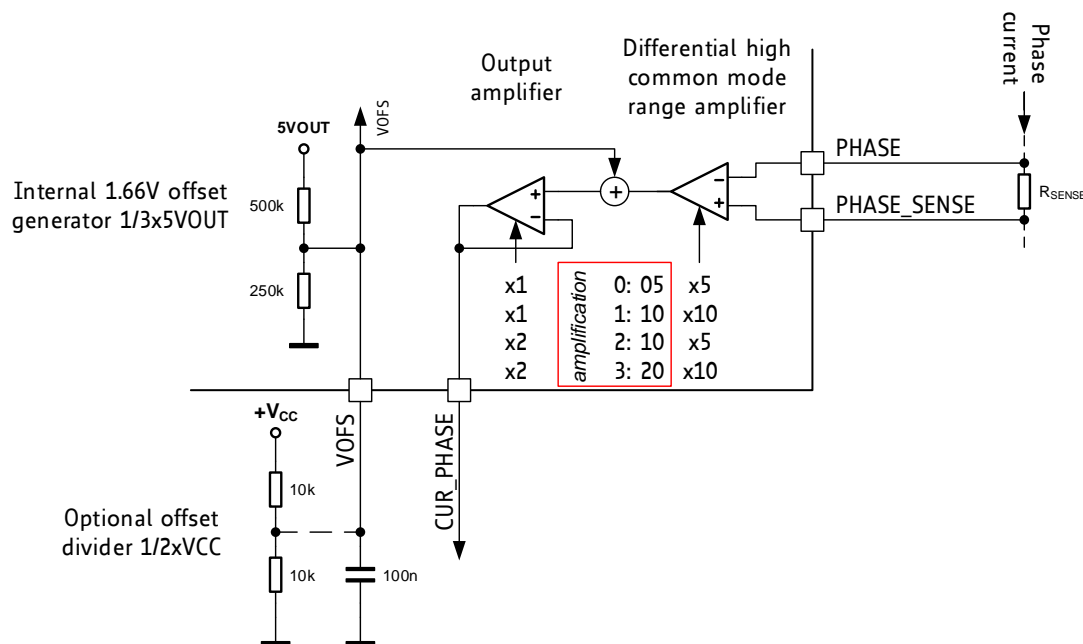

Figure 6.1 Principle of sense amplifier

The sense amplifier transfer function is determined by the following equation:

$$CUR_{PHASE} = VOFS - amplification * (R_{SENSE} * I_{PHASE} + V_{INOFFS})$$

Where

I_{PHASE} is the current flowing into the motor terminal.

V_{INOFFS} is a random offset voltage in the range of a few to a few 10mV of the input amplifier.

Determine and compensate for by measuring output offset at zero current prior to motor operation.

6.1 Settling Time

By principle, the disturbance of the coil series current measurement during switching events is low. But, for the measurement amplifier, a switching event means a common mode signal change equal to the height of the supply voltage. This switching temporarily disturbs the measurement and should be blanked away. Therefore, sampling of the outputs should be synchronized to the chopper operation, because switching slopes lead to disturbances and become visible as spikes at the output (see Figure 6.2). The amplifier will recover within a few microseconds after each switching event. An increased

settling time can result from increased length of motor cables and capacitive load on the cables, or parasitic inductivity of the sense resistors.

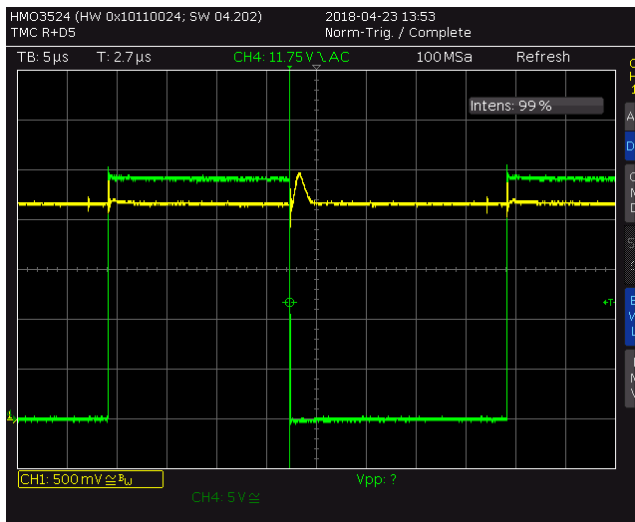

Figure 6.2 Amplifier Settling after coil switch event (Green: Coil output, Yellow: Amplifier output)

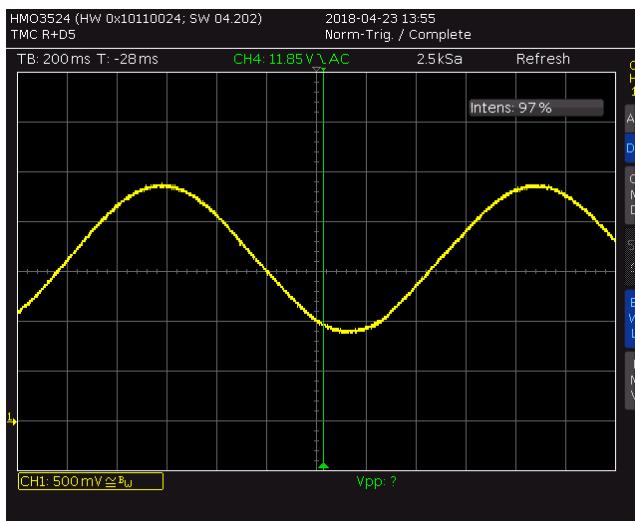

Figure 6.3 Output correctly sampled with sine wave current and 1.66V offset

Attention

Each switching event on one of the motor outputs will cause a spike on the related current measurement amplifier output. Its settling time of roughly $2\mu\text{s}$ to $4\mu\text{s}$ (depending on supply voltage and sense resistors) should be blanked away by ignoring the output voltage during this time. This can be ensured when the external ADC samples the output synchronously with the chopper period.

6.2 Current Amplifier Offset

6.2.1 Initial Offset

The amplifiers have a good amplification tolerance, but due to production stray, they show a random offset voltage (see Figure 6.4). Offset voltage especially concerns input offset, as the input offset voltage becomes amplified by the actual amplifications setting, i.e. factor 5, 10 or 20. Therefore, a higher amplification setting means a higher offset voltage and higher offset stray. To compensate for this offset (V_{INOF5}), individually sample the amplifier outputs while the motor driver is disabled and use

the resulting value as zero-reference. When changing amplification in the application, scale the offset measured with a different amplification accordingly.

6.2.2 Thermal Drift

Further, the offset has a random certain thermal drift. Figure 6.5 shows an example. Thermal drift especially concerns applications, where the IC heats up significantly during operation. Thermal compensation therefore becomes necessary, when low motor currents have to be exactly measured in a high current application, e.g., for field-oriented motor control. As the thermal drift basically shows a linear dependence on the temperature, taking offset measurements at two temperature values will be sufficient for linear interpolation and extrapolation of the actual offset. Therefore, board temperature near the IC / near the power stage shall be measured. Compensation based on an initial testing phase temperature curve per channel will be sufficient.

Example for offset compensation including thermal drift compensation:

- 1) Measure and compensate initial value at each power-up of the IC.
- 2) When the unit is powered up for the *first time*, store temperature and offset value for each channel
- 3) When the unit reaches a certain increased temperature for the *first time* (e.g. +40°C more than at step 2), redo 1) and store temperature and offset values to EEPROM.
- 4) Use the results of steps 2) and 3) for compensating thermal drift during operation, by interpolating between and extrapolating beyond the stored values

For applications with continuous motor operation, a floating mean value should be sufficient to compensate for amplifier offset.

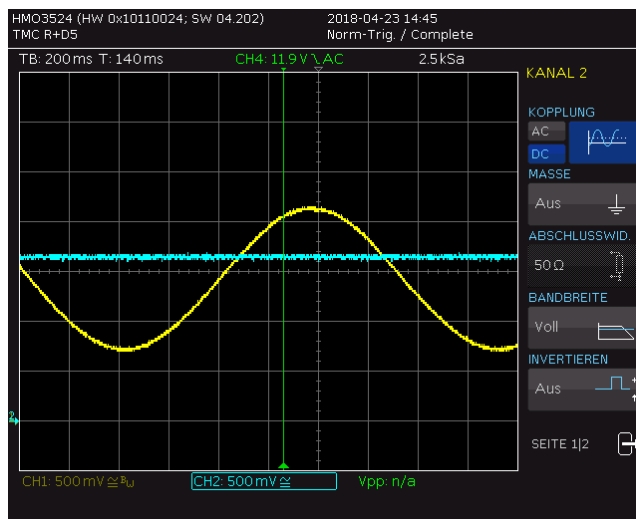

Figure 6.4 Random Output Offset at 20x amplification (Yellow: Output, Blue: VOFS input)

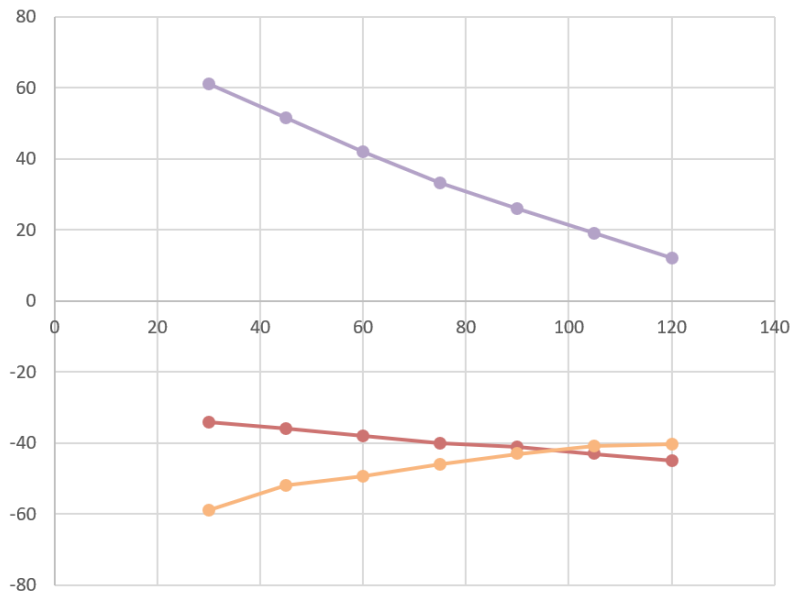

Figure 6.5 Example for Thermal Offset Drift at output (5x amplification) [mV] from 30°C to 120°C

Attention

The current amplifiers show a random offset. It has to be compensated individually for each channel in order to yield the absolute current. An initial compensation (after power-up) will basically eliminate most of this offset. Further, the current amplifiers show a random thermal drift. For applications, which significantly heat up during operation, this thermal effect should be compensated by either of these methods:

- a) floating AC mean value (AC coupling)
- b) linearized two-point compensation using stored values and temperature measurement
- c) repeated compensation after a certain amount of heat up / time (may be stored and used for b))

Measure power stage temperature near the IC to allow for thermal compensation of offset!

Attention

When operating in conjunction with the TMC4671 or TMC8670, a compensation of the drift is not possible. Therefore, we recommend using the internal sensing only for applications with low temperature range, and for tiny applications up to 8A, using 5 times amplification of the sense amplifier, which exhibits the lowest relative drift. For higher motor current, use external sense amplifiers.

6.3 Choice of Sense Resistors

Choose sense resistors fitting the maximum motor current desired. Be sure to provide sufficient headroom for your current regulation loop to operate the motor at short time peak currents. A regulation loop always needs a headroom of 25% to 50%. The following table shows a choice of standard resistors (partially yielded by paralleling two resistors) and the peak currents which can safely be measured with 1.65V or 2.5V Offset voltage. The choice of amplification is shown as second parameter. An amplification of 20 only can be set when using the SPI interface.

CHOICE OF R_{SENSE} AND AMPLIFICATION DEPENDING ON MAX. COIL CURRENT				
R_{SENSE} [m Ω]	Amplification factor	Current range [A]	RMS motor current limit [A]	Max. power dissipation of R_{SENSE} [W]
150	10	0.7	0.5	0.05
150	5	1.3	1	0.15
100	5	2	1.5	0.23
75	5	2.6	2	0.3
33	10	3	2.2	0.16
25	10	4	3	0.23
50	5	4	3	0.45
33	5	6	4.5	0.67
15	10	6.5	5	0.38
25	5	8	6	0.9
10	10	10	7.5	0.56
5	10	20	15	1.1
2.5	20	20	15	0.56
2.5	10	40	30	2.3
1	20	50 (40@1.65V ofs.)	37	1.4

Sense resistors should be carefully selected. The full motor current flows through the sense resistors. Due to chopper operation the sense resistors see pulsed current from the MOSFET bridges. Therefore, a low-inductance type such as film or composition resistors is required to prevent voltage spikes causing ringing on the sense voltage inputs leading to unstable measurement results. Also, a low-inductance, low-resistance PCB layout is essential. Please also refer to layout considerations in chapter 12. With low resistor values, it becomes more critical to do symmetrical and low resistive PCB traces.

CALCULATION OF PEAK SENSE RESISTOR POWER DISSIPATION

$$P_{RSMAX} = I_{COIL}^2 * R_{SENSE}$$

Hint

For best precision of current measurement, it is advised to measure and fine tune the current in the application. Choose the sense resistors to the next value covering the desired motor peak current.

Attention

Be sure to use a symmetrical sense resistor layout for each bridge and short and straight sense resistor traces of identical length. Well matching sense resistors ensure best performance. A compact layout with massive ground plane is best to avoid parasitic resistance effects.

7 Diagnostics and Protection

The TMC6200 supplies a complete set of diagnostic and protection capabilities, like short circuit protection and undervoltage detection. See the *DRV_STATUS* table for details.

7.1 Temperature Sensors

The driver integrates a four-level temperature sensor (120°C pre-warning and selectable 136°C / 143°C / 150°C thermal shutdown) for diagnostics and for protection of the IC and the power MOSFETs and adjacent components against excess heat. Choose the overtemperature level to safely cover error conditions like missing heat convection. Heat is mainly generated by the power MOSFETs, and, at increased voltage, by the internal voltage regulators. For many applications, already the overtemperature pre-warning will indicate an abnormal operation situation and can be used to initiate user warning or power reduction measures like motor current reduction. The thermal shutdown is just an emergency measure and temperature rising to the shutdown level should be prevented by design.

After triggering the overtemperature sensor (*ot* flag), the driver remains switched off until the system temperature falls below the pre-warning level (*otpw*) to avoid continuous heating to the shutdown level.

7.2 Short Protection

The TMC6200 protects the MOSFET power stages against a short circuit or overload condition by monitoring the voltage drop in the high-side MOSFETs, as well as the voltage drop in the low-side MOSFETs (Figure 7.1). A programmable short detection delay (*shortdelay*) allows adjusting the detector to work with very slow switching slopes. Additionally, the short detector allows filtering of the signal. This helps to prevent spurious triggering caused by effects of PCB layout, or long, adjacent motor cables (*SHORTFILTER*). All control bits are available via register *SHORT_CONF*. Additionally, the short detection is protected against single events, e.g., caused by ESD discharges, by retrying up to three times before switching off the motor continuously (program in *SHORT_CONF.RETRY*).

Parameter	Description	Setting	Comment
<i>S2VS_LEVEL</i>	Short or overcurrent detector level for lowside FETs. Checks for voltage drop in LS MOSFET and optional bottom shunt resistor. <i>Hint: May be tuned for sensitive detection.</i>	4...15	1 (highest sensitivity) ... 15 (lowest sensitivity) (Reset Default: OTP 6 / 12)
<i>S2G_LEVEL</i>	<i>S2G_LEVEL</i> : Short to GND detector level for highside FETs. Checks for voltage drop on high side MOSFET.	2...15	2 (highest sensitivity) ... 15 (lowest sensitivity) (Reset Default: OTP 6 / 12)
<i>SHORT_FILTER</i>	Spike filtering bandwidth for short detection <i>Hint: Increase value if erroneous short detection occurs.</i>	0...3	0 (lowest, 100ns), 1 (1µs) (Reset Default), 2 (2µs), 3 (3µs)
<i>RETRY</i>	Number of retries after short detection until permanent bridge shutdown	0...3	(Reset Default = 3)
<i>shortdelay</i>	<i>shortdelay</i> : Short detection delay The delay shall cover the bridge switching time.	0/1	0=750ns: normal, 1=1500ns: high
<i>disable_S2VS</i>	1: Disable short to VS protection.	0/1	Leave detection enabled for normal use (0).
<i>disable_S2G</i>	1: Disable short to GND protection.	0/1	Leave detection enabled for normal use (0).
<i>protectparallel</i>	0: Individual half bridge protection 1: Disable all bridges upon single half bridge short condition	0/1	(Reset Default = 1)

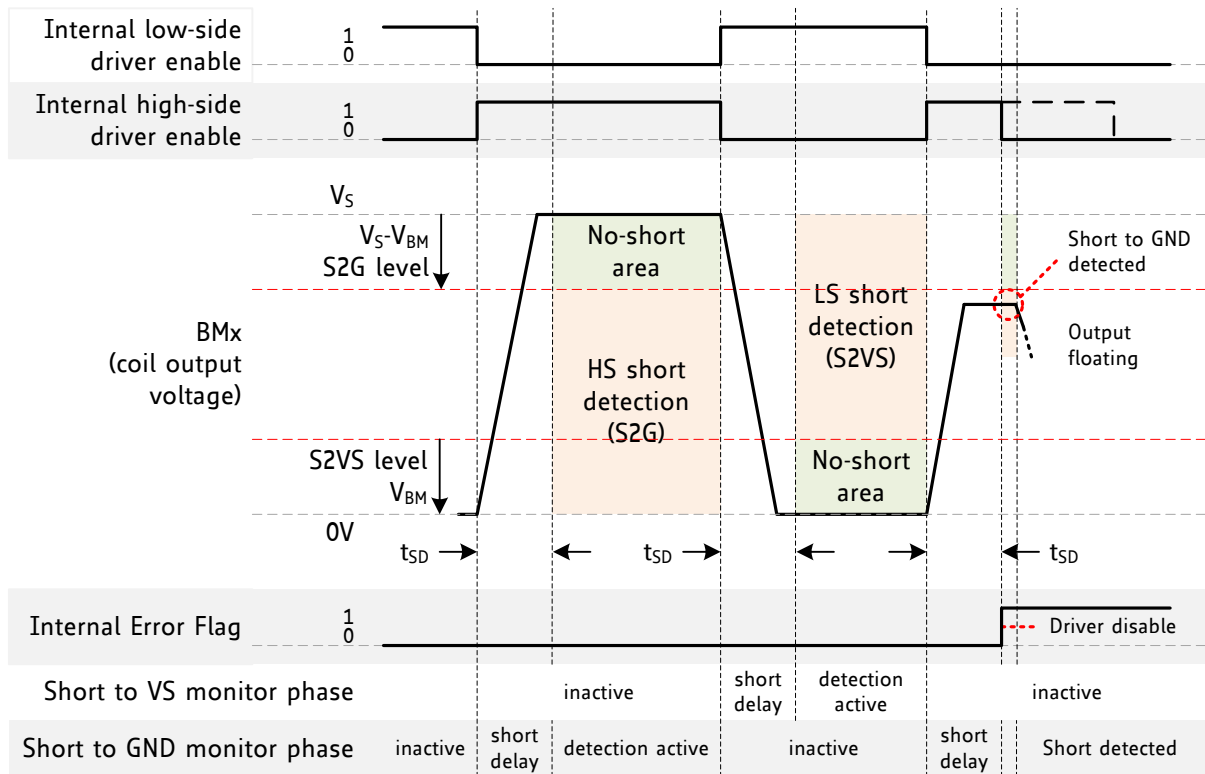

Figure 7.1 Short detection (U, V or W output)

In case a bottom shunt sense resistor is used, low-side short detection can be set to a high sensitivity and provides good precision of current detection. This way, it will safely cover most overcurrent conditions, i.e., when commutation errors occur.

Once a short condition is safely detected, the corresponding driver bridge (U, V or W) becomes switched off, and the corresponding *s2gu*, *s2gv* or *s2gw* flag, respectively *s2vsu*, *s2vsv* or *s2vsw* becomes set. Optionally, the complete bridge becomes switched off (set *protect_parallel*). To restart the motor, disable and re-enable the driver.

Attention:
Short protection cannot protect the system and the power stages for all possible short events, as a short event is rather undefined, and a complex network of external components may be involved. Therefore, short circuits should basically be avoided.

Hint
Fine tune low-side short detection threshold, to provide a sensitive overcurrent protection, e.g., to protect motor and power stage. The reproducibility mainly depends on production stray of the MOSFETs and is typically within +30%. To see any overcurrent pulse at the FAULT output, set flag *short_direct*.
Set a high value for high-side short protection because detection is more subject to stray and inductive voltage drop on interconnections.

8 Power-Up Reset

The chip is loaded with default values during power-up via its internal power-on reset. It will also reset to power-up defaults in case any of the supply voltages monitored by internal reset circuitry (VSA, +5VOUT or VCC_IO) falls below the undervoltage threshold. In case of a microcontroller software re-boot, disable the driver and re-initialize all registers used by the software. A hardware reset requires cycling VCC_IO while keeping all digital inputs at a low level at the same time. Actively drive VCC_IO to a low level to ensure that it falls below the lower reset threshold. Current consumed from VCC_IO is low and therefore it has simple driving requirements. Due to the input protection diodes not allowing the digital inputs to rise above VCC_IO level, any active high input would hinder VCC_IO from going down.

9 Clock Oscillator and Input

The clock is the timing reference for the internal BBM time generator and is used to operate the SPI interface. The factory-trimmed on-chip clock oscillator provides timing which is sufficient for most use cases.

9.1 Using the Internal Clock

Directly tie the CLK input to GND near to the IC if the internal clock oscillator is to be used. It provides a precision of roughly $\pm 4\%$, which is precise enough for BBM operation.

9.2 Using an External Clock

When an external clock is available, a frequency of 4 MHz to 13.4 MHz is possible (max. 16MHz with 50% dutycycle). Especially with low clock frequency, make sure, that the SPI timing is kept in order to ensure proper SPI operation. Make sure, that the clock source supplies clean CMOS output logic levels and steep slopes when using a high clock frequency. The external clock input is enabled with the second positive polarity seen on the CLK input.

Attention

Switching off the external clock frequency prevents the driver from operating normally. Therefore, an internal watchdog switches back to internal clock in case the external signal is missing for more than roughly 32 internal clock cycles.

9.2.1 Considerations on the Frequency

A higher frequency allows more precise BBM timing and faster SPI operation. A lower frequency will reduce power consumption of the IC, which especially at high VSA supply voltages reduces overall power consumption by a few 100mW. However, the internal timing should be sufficient for most applications. Take into account, that the input signals are synchronized to the clock, in case internal BBM generation becomes used.

10 Absolute Maximum Ratings

The maximum ratings may not be exceeded under any circumstances. Operating the circuit at or near more than one maximum rating at a time for extended periods shall be avoided by application design.

Parameter	Symbol	Min	Max	Unit
Supply voltage operating with inductive load	V_{VS}, V_{VSA}	-0.5	65	V
Supply and bridge voltage short time peak (limited by peak voltage on charge pump output and Cxx pins*)	V_{VSMAX}		70	V
VSA supply voltage	V_{VSAMAX}	-0.5	65	V
Peak voltages on Cxx bootstrap pins and VCP	V_{CXCXCP}		85	V
Supply voltage V12	V_{12VOUT}	-0.5	15	V
Peak voltages on U/V/W pins (due to stray inductivity)	V_X	-6	$V_{VS}+6$	V
Peak voltages on Cxx bootstrap pins relative to BM	V_{CXX}	-0.5	16	V
I/O supply voltage	V_{VIO}	-0.5	5.5	V
Supply voltage (5VOUT)	V_{5VOUT}	-0.5	5.5	V
Logic input voltage	V_I	-0.5	$V_{VIO}+0.5$	V
Maximum current to / from digital pins and analog low voltage I/Os (short time peak current)	I_{IO}		+/-500	mA
Maximum differential input voltage for current amplifier	V_X-V_{SENSEX}		+/-1.5	V
Maximum short time input current for current amplifier	I_{SENSEX}		+/-200	mA
5V regulator output current (internal plus external load)	I_{5VOUT}		30	mA
5V regulator continuous power dissipation $(V_{VSA}-5V) * I_{5VOUT}$	P_{5VOUT}		1	W
12V regulator output current (internal plus external load)	I_{12VOUT}		20	mA
12V regulator continuous power dissipation $(V_{VM}-5V) * I_{5VOUT}$	P_{12VOUT}		0.5	W
Junction temperature	T_J	-50	150	°C
Storage temperature	T_{STG}	-55	150	°C
ESD-Protection for interface pins (Human body model, HBM)	V_{ESDAP}		4	kV
ESD-Protection for handling (Human body model, HBM)	V_{ESD}		1	kV

*) Stray inductivity of power routing will lead to ringing of the supply voltage when driving an inductive load. This ringing results from the fast switching slopes of the driver outputs in combination with reverse recovery of the body diodes of the output driver MOSFETs. Even small trace inductivities as well as stray inductivity of sense resistors can easily generate a few volts of ringing leading to temporary voltage overshoot. This should be considered when working near the maximum voltage.

11 Electrical Characteristics

11.1 Operational Range

Parameter	Symbol	Min	Max	Unit
Junction temperature	T_J	-40	125	°C
Supply voltage for motor and bridge	V_{VS}	10	60	V
Supply voltage VSA	V_{VSA}	10	60	V
Supply voltage for VSA and 12OUT (internal gate voltage regulator bridged)	V_{12VOUT}, V_{VSA}	10	13	V
Lower Supply voltage (reduced spec, short to GND protection not functional), lower limit depending on MOSFETs gate threshold voltage and load current	V_{VS}	8		V
I/O supply voltage	V_{VIO}	3.00	5.25	V

11.2 DC and Timing Characteristics

DC characteristics contain the spread of values guaranteed within the specified supply voltage range unless otherwise specified. Typical values represent the average value of all parts measured at +25°C. Temperature variation also causes stray to some values. A device with typical values will not leave Min/Max range within the full temperature range.

Power Supply Current	DC-Characteristics					
	$V_{VS} = V_{VSA} = 24.0V$					
Parameter	Symbol	Conditions	Min	Typ	Max	Unit
Total supply current, driver disabled $I_{VS} + I_{VSA}$	I_S	internal clock		11	15	mA
VSA supply current (VS and VSA separated)	I_{VSA}	$f_{CLK}=24MHz$ / internal clock, driver disabled		8		mA
Internal current consumption from 5V supply on VCC pin	I_{VCC}	$f_{CLK}=24MHz$		6		mA
IO supply current (typ. at 5V)	I_{VIO}	no load on outputs, inputs at V_{IO} or GND Excludes pullup / pull-down resistors		15	30	μA

Motor Driver	DC- and Timing-Characteristics					
	$V_{VS} = 24.0V$; $T_j=50^\circ C$					
Parameter	Symbol	Conditions	Min	Typ	Max	Unit
RDS _{ON} low-side off driver	R_{ONL}	Gate off		1.0	1.6	Ω
RDS _{ON} high-side off driver	R_{ONH}	Gate off		1.3	2.0	Ω
Gate drive current low side MOSFET turning on at 2V V_{GS}	I_{SLPON0}	<i>DRIVESTRENGTH=0</i>		400		mA
	I_{SLPON2}	<i>DRIVESTRENGTH=2</i>		800		mA
	I_{SLPON3}	<i>DRIVESTRENGTH=3</i>		1200		mA
Gate drive current high side MOSFET turning on at 2V V_{GS}	I_{SLPON0}	<i>DRIVESTRENGTH=0</i>		400		mA
	I_{SLPON2}	<i>DRIVESTRENGTH=2</i>		800		mA
	I_{SLPON3}	<i>DRIVESTRENGTH=3</i>		1200		mA
Gate drive current low side MOSFET turning off at 4V V_{GS}	$I_{SLPOFF0}$	<i>DRIVESTRENGTH=0</i>		600		mA
	$I_{SLPOFF2}$	<i>DRIVESTRENGTH=2</i>		1200		mA
	$I_{SLPOFF3}$	<i>DRIVESTRENGTH=3</i>		1800		mA
Gate drive current high side MOSFET turning on at 4V V_{GS}	$I_{SLPOFF0}$	<i>DRIVESTRENGTH=0</i>		600		mA
	$I_{SLPOFF2}$	<i>DRIVESTRENGTH=2</i>		1200		mA
	$I_{SLPOFF3}$	<i>DRIVESTRENGTH=3</i>		1800		mA
Minimum effective BBM time enforced in individual or single line mode	t_{BBM0}	Individual LS and HS signals (<i>singleline=0</i>)	30	50	70	ns
Reaction delay time LS/HS input signal change to start of gate driver output change	t_{DLY}	Individual LS and HS signals (<i>singleline=0</i>)	65	85	110	ns
Matching difference of gate driver reaction delay times	$t_{DLYMATCH}$	Individual LS and HS signals (<i>singleline=0</i>)			10	ns

Charge Pump		DC-Characteristics				
Parameter	Symbol	Conditions	Min	Typ	Max	Unit
Charge pump output voltage	$V_{VCP-V_{VS}}$	operating	$V_{12VOUT} - 2$	$V_{12VOUT} - 1$		V
Charge pump voltage threshold for undervoltage detection	$V_{VCP-V_{VS}}$	rising, using internal 5V regulator voltage	4.5	5.5	6.5	V
Charge pump frequency	f_{CP}			$1/32 f_{CLKOSC}$		

Linear Regulator		DC-Characteristics				
$V_{VS} = V_{VSA} = 24.0V$						
Parameter	Symbol	Conditions	Min	Typ	Max	Unit
Output voltage	V_{5VOUT}	$T_J = 25^\circ C$	4.80	5.0	5.20	V
Deviation of output voltage over the full temperature range	$V_{5VOUT(DEV)}$	drivers disabled $T_J = \text{full range}$		+/-5	+/-50	mV
Deviation of output voltage over the supply voltage	$V_{5VOUT(DEV)}$	drivers disabled, internal clock $T_A = 25^\circ C$ $V_{VSA} = 10V \text{ to } 30V$			+/-20	mV / 10V
Output voltage	V_{12VOUT}	operating, internal clock $T_J = 25^\circ C$	10.8	11.5	12.2	V

Clock Oscillator and Input		Timing-Characteristics				
Parameter	Symbol	Conditions	Min	Typ	Max	Unit
Clock oscillator frequency (factory calibrated)	f_{CLKOSC}	$t_j = -50^\circ C$		23.4		MHz
	f_{CLKOSC}	$t_j = 50^\circ C$	23	24.0	25	MHz
	f_{CLKOSC}	$t_j = 150^\circ C$		24.2		MHz
External clock frequency (operating)	f_{CLK}	40%..60% dutycycle for typ. 50% for max.	4	10-13.4	16	MHz
External clock high / low level time	t_{CLKH} / t_{CLKL}	CLK driven to $0.1 V_{VIO} / 0.9 V_{VIO}$	10			ns
External clock timeout detection in cycles of internal f_{CLKOSC}	t_{CLKH1}	CLK driven high	32		48	cycles f_{CLKOSC}

Short Detection	DC-Characteristics					
Parameter	Symbol	Conditions	Min	Typ	Max	Unit
Short to GND / Short to VS detector delay (Start of gate switch on to short detected) Including 100ns filtering time	t_{SD0}	<i>FILT_ISENSE=0</i> <i>S2xx_LEVEL=6</i> <i>shortdelay=0</i>	0.5	0.85	1.1	μ s
	t_{SD1}	<i>shortdelay=1</i>	1.1	1.6	2.2	μ s
Short detector level S2VS (measurement includes drop in opt. bottom shunt resistor)	V_{BM}	<i>S2VS_LEVEL=15</i>	1.4	1.56	1.72	V
		<i>S2VS_LEVEL=6</i>	0.55	0.625	0.70	V
Short detector level S2G	$V_S - V_{BM}$	<i>S2G_LEVEL=15</i> <i>VS<52V</i>	1.3	1.56	1.85	V
		<i>S2G_LEVEL=15</i> <i>VS<60V</i>	1.0			V
		<i>S2G_LEVEL=6</i> <i>VS<52V</i>	0.46	0.625	0.85	V
		<i>S2G_LEVEL=6</i> <i>VS<60V</i>	0.20			V

Detector Levels	DC-Characteristics					
Parameter	Symbol	Conditions	Min	Typ	Max	Unit
V_{VSA} undervoltage threshold for RESET	V_{UV_VSA}	V_{VSA} rising	3.8	4.2	4.6	V
V_{SVOUT} undervoltage threshold for RESET	V_{UV_SVOUT}	V_{SVOUT} rising		3.5		V
V_{VCC_IO} undervoltage threshold for RESET	V_{UV_VIO}	V_{VCC_IO} rising (delay typ. 10 μ s)	2.0	2.2	3.0	V
V_{VCC_IO} undervoltage detector hysteresis	$V_{UV_VIOHYST}$			0.3		V
Overtemperature prewarning 120°C	T_{OTPW}	Temperature rising	100	120	140	°C
Overtemperature shutdown 136 °C	T_{OT136}	Temperature rising		136		°C
Overtemperature shutdown 143 °C	T_{OT143}	Temperature rising		143		°C
Overtemperature shutdown 150 °C	T_{OT150}	Temperature rising	135	150	170	°C

Sense Amplifiers		DC-Characteristics				
		T _j =50°C				
Parameter	Symbol	Conditions	Min	Typ	Max	Unit
Duration of Disturbance on sense amplifier output after switching event / settling time	t _{SETTLING}	V _{VS} =24V		2	3	μs
		V _{VS} =50V		3	4	μs
Amplification	A _{AMPL}	amplification=0	4.85	5	5.15	V/V
		amplification=1 or 2		10		V/V
		amplification=3		20		V/V
Current amplifier differential input voltage range with V _{OFS} =2.5V	V _{DIFF}	amplification=0	-250		+250	mV
		amplification=1 or 2	-150		+150	mV
		amplification=3	-75		+75	mV
Current amplifier differential input voltage range with V _{OFS} =1.65V	V _{DIFF}	amplification=0	-200		+200	mV
		amplification=1 or 2	-100		+100	mV
		amplification=3	-40		+40	mV
Amplification absolute tolerance	A _{ABSTOL}		-3		+3	%
Amplification matching between channels	A _{MATCH}	Tested at 1/2 full scale	-2		+2	%
Offset voltage variation over sense input voltage (output)	V _{OFSVAR}	V _{sense} =0V to 50V amplification=0	-10	0	+10	mV
Offset voltage variation (input) over temperature *)	V _{OFSVART}		-0.25	+0.1	+0.25	mV/°C
Offset voltage variation (output) over temperature *)	V _{OFSVART100}	25°C to 125°C amplification=0 (5x)	-125	+50	+125	mV/ 100°C
Current amplifier input voltage range for normal operation	V _{SENSEI} , V _{BM}		-1		V _{VS} +1V	V
Current amplifier output offset voltage with regard to VOFS	V _{OFS}	amplification=0	-130		+130	mV
		amplification=1/2	-250		+250	mV
		amplification=3	-500		+500	mV
Current amplifier output voltage range	V _{CUR}		0.1	V _{VOFS} +1.5	V _{SVOUT} -0.1	V
VOFS input voltage range	V _{VOFS}		1.5	1.65V or 2.5V	2.7	V
Sense amplifier output resistance	R _{CUR}		36	56	76	Ω
Sense amplifier output current	I _{CUR}	Swing 250mV to V _{SVOUT} -500mV	-1		+1	mA
Input Resistance VOFS pin	R _{VOFS}		130	165	210	kΩ
Output voltage with VOFS open	V _{VOFS}			V _{SVOUT} /3		V

*) Parameter characterized by sampling, only

Digital pins	DC-Characteristics					
Parameter	Symbol	Conditions	Min	Typ	Max	Unit
Input voltage low level	V_{INLO}		-0.3		$0.3 V_{VIO}$	V
Input voltage high level	V_{INHI}		$0.7 V_{VIO}$		$V_{VIO}+0.3$	V
Input Schmitt trigger hysteresis	V_{INHYST}			$0.12 V_{VIO}$		V
Output voltage low level	V_{OUTLO}	$I_{OUTLO} = 2mA$			0.2	V
Output voltage high level	V_{OUTH}	$I_{OUTH} = -2mA$	$V_{VIO}-0.2$			V
Input leakage current	I_{LEAK}		-10		10	μA
Pullup / pull-down resistors	R_{PU}/R_{PD}		132	166	200	k Ω
Digital pin capacitance	C			3.5		pF

11.3 Thermal Characteristics

The following table shall give an idea on the thermal resistance of the package. The thermal resistance for a four-layer board will provide a good idea on a typical application. Actual thermal characteristics will depend on the PCB layout, PCB type and PCB size. The thermal resistance will benefit from thicker CU (inner) layers for spreading heat horizontally within the PCB. Also, air flow will reduce thermal resistance.

Parameter	Symbol	Conditions	Typ	Unit
Typical power dissipation	P_D	20kHz chopper, 24V supply, internal supply regulators	<0.5	W
Thermal resistance junction to ambient on a multilayer board	R_{TMJA}	Dual signal and two internal power plane board (2s2p) as defined in JEDEC EIA JESD51-5 and JESD51-7 (FR4, 35 μm CU, 70mm x 133mm, d=1.5mm)	21	K/W
Thermal resistance junction to board	R_{TJB}	PCB temperature measured within 1mm distance to the package leads	8	K/W
Thermal resistance junction to case	R_{TJC}	Junction temperature to heat slug of package	3	K/W

Table 11.1 Thermal characteristics TQFP48-EP

The thermal resistance in an actual layout can be tested by checking for the heat up caused by the standby power consumption of the chip. When no motor is attached, all power seen on the power supply is dissipated within the chip.

12 Layout Considerations

12.1 Exposed Die Pad

The TMC6200 uses its die attach pad to dissipate heat from the gate drivers and the linear regulator to the board. For best electrical and thermal performance, use a reasonable amount of solid, thermally conducting vias between the die attach pad and the ground plane. The printed circuit board should have a solid ground plane spreading heat into the board and providing for a stable GND reference.

12.2 Wiring GND

All signals of the TMC6200 are referenced to their respective GND. Directly connect all GND pins under the device to a common ground area (GND, GNDP, GNDA and die attach pad). The GND plane right below the die attach pad should be treated as a virtual star point. For thermal reasons, the PCB top layer shall be connected to a large PCB GND plane spreading heat within the PCB.

Attention

Place the TMC6200 near to the MOSFET bridge in order to avoid ringing leading to GND differences.

12.3 Wiring Bridge Supply

The power bridge will draw the full coil current in pulses with extremely high dI/dt . Thus, any inductivity between VS supply filtering and the MOSFETs can lead to severe voltage spikes. This has to be avoided. Avoid any bend in the supply traces between filtering capacitors and MOSFET switches and keep distance as small as possible. Especially for high current, use a separate plane for the supply voltage, and a sufficient number and capacity for supply filtering. Use an additional capacitor for the IC VS pin, as additional ripple voltage would cause severe current spikes on the charge pump capacitor. A tiny series resistor can be added to avoid this.

Attention

Keep supply voltage ripple low, by using sufficient filtering capacity close to the MOSFET bridge.

12.4 Supply Filtering

The 5VOUT output voltage ceramic filtering capacitor (2.2 to 4.7 μ F recommended) should be placed as close as possible to the 5VOUT pin, with its GND return going directly to the GNDA pin. This ground connection shall not be shared with other loads or additional vias to the GND plane. Use as short and as thick connections as possible. A 100 nF or larger filtering capacitor should be placed as closely as possible to the VSA pin to ground plane. Provide sufficient filtering capacity near the power bridge MOSFETs, to avoid ringing following each switching event. Make sure, that VS does not see excessive voltage spikes caused by bridge operation and place a 100 nF or larger filter capacitor to GND close to the VS pin.

Please carefully read chapters 3.4 and 3.5 to understand the special considerations with regard to layout and component selection for the external MOSFET power bridges.

12.5 Layout Example

Schematic extract of TMC6200-EVAL (TMC6200+MOSFETs shown)

Motor Driver

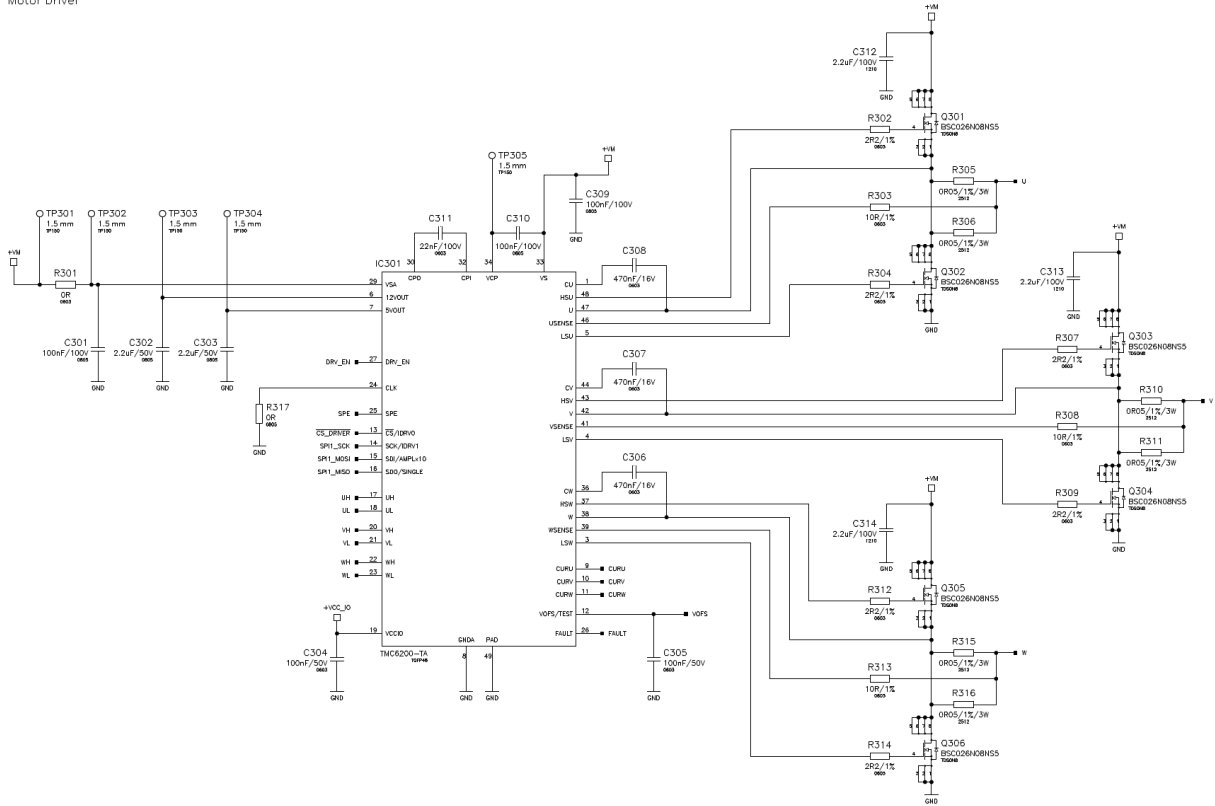

1- Top Layer (assembly side)

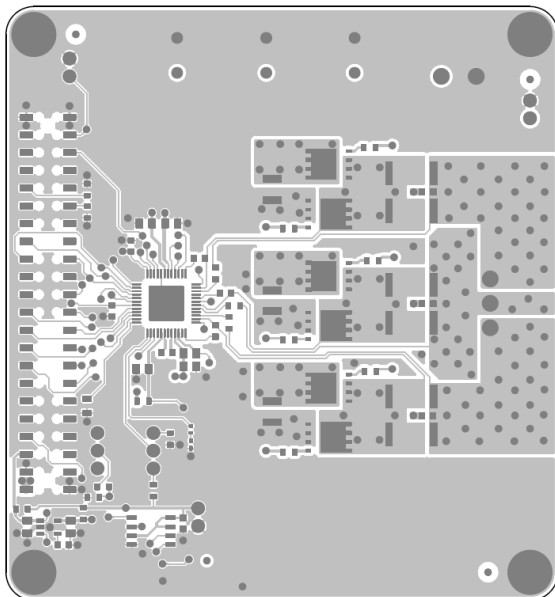

2- Inner Layer (GND)

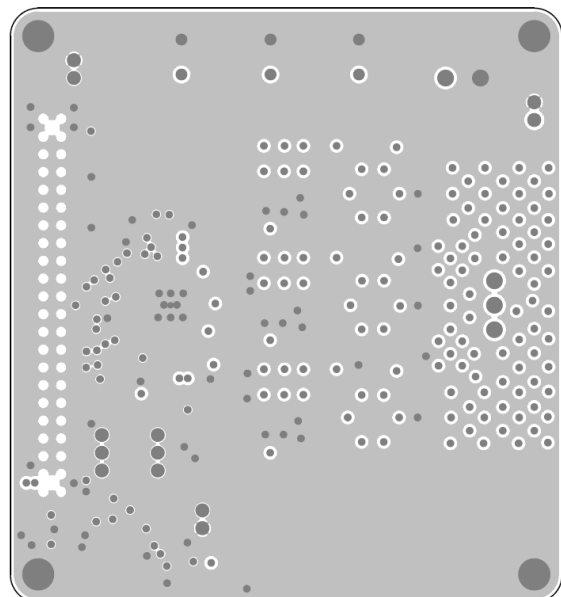

3- Inner Layer (supply VS)

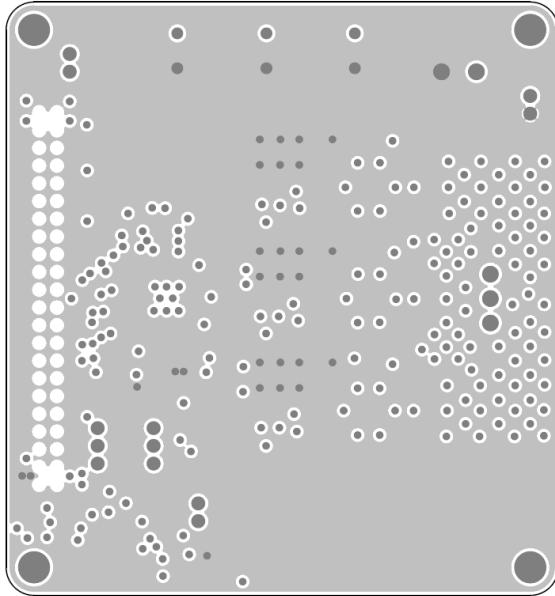

4- Bottom Layer

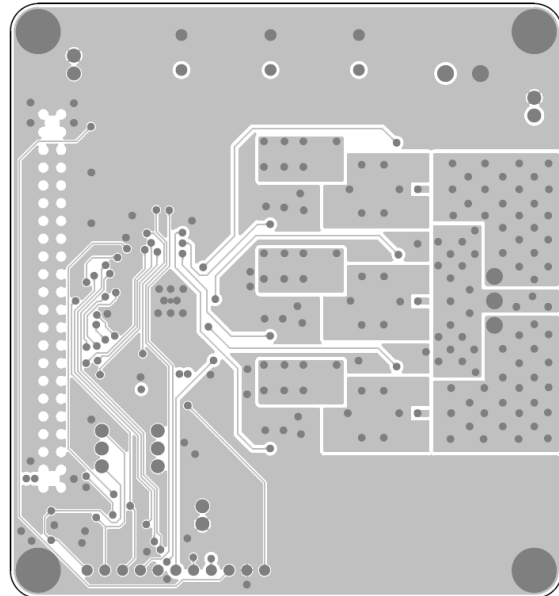

Components

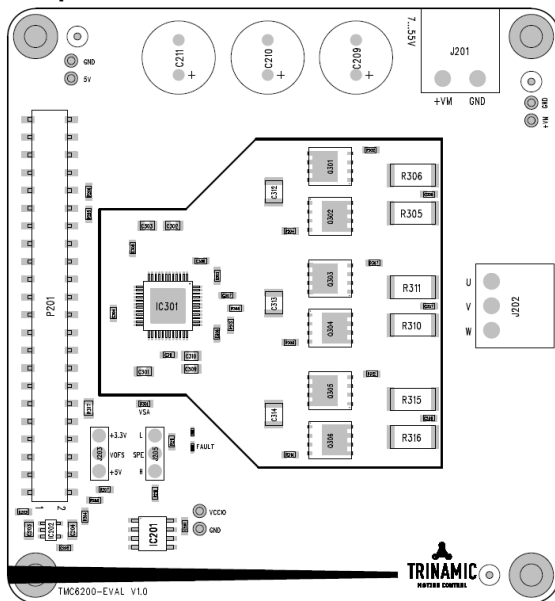

Figure 12.1 Layout example

Please refer www.trinamic.com for complete schematic and layout data of the evaluation board.

13 Package Mechanical Data

13.1 Dimensional Drawings TQFP48-EP

Attention: Drawings not to scale.

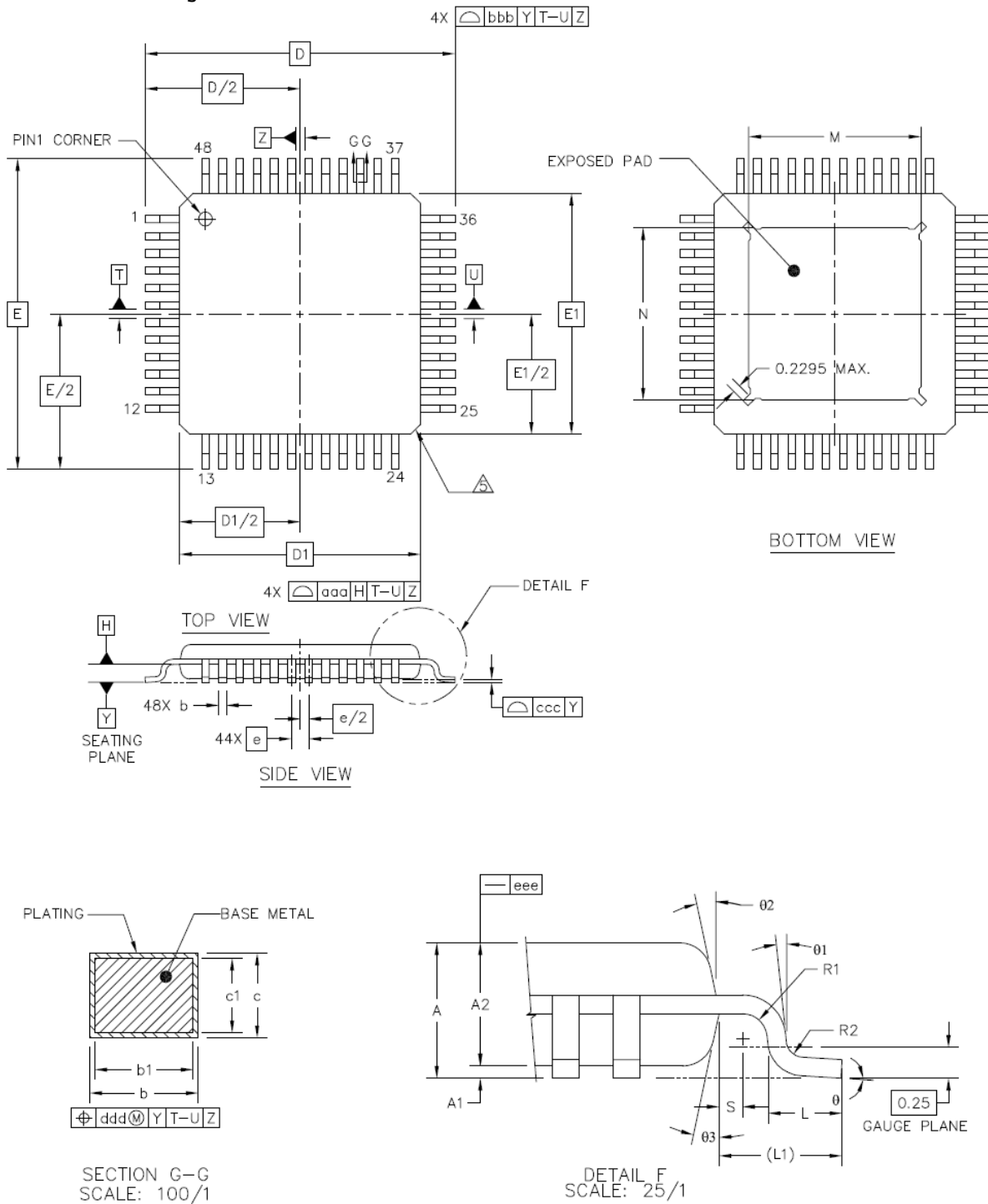

Figure 13.1 Dimensional drawings TQFP48-EP

Parameter	Ref	Min	Nom	Max
total thickness	A	-	-	1.2
stand off	A1	0.05	-	0.15
mold thickness	A2	0.95	1	1.05
lead width (plating)	b	0.17	0.22	0.27
lead width	b1	0.17	0.2	0.23
lead frame thickness (plating)	c	0.09	-	0.2
lead frame thickness	c1	0.09	-	0.16
body size X (over pins)	D		9.0	
body size Y (over pins)	E		9.0	
body size X	D1		7.0	
body size Y	E1		7.0	
lead pitch	e		0.5	
lead	L	0.45	0.6	0.75
footprint	L1		1 REF	
	⊖	0°	3.5°	7°
	⊖1	0°	-	-
	⊖2	11°	12°	13°
	⊖3	11°	12°	13°
	R1	0.08	-	-
	R2	0.08	-	0.2
	S	0.2	-	-
exposed die pad size X	M	4.9	5	5.1
exposed die pad size Y	N	4.9	5	5.1
package edge tolerance	aaa			0.2
lead edge tolerance	bbb			0.2
coplanarity	ccc			0.08
lead offset	ddd			0.08
mold flatness	eee			0.05

13.2 Package Codes

Type	Package	Temperature range	Code & marking	MSL level
TMC6200-TA	TQFP-EP48 (RoHS)	-40°C ... +125°C	TMC6200-TA	MSL 3 / 160h
TMC6200-TA-T	Tape on reel packed products			

14 Disclaimer

TRINAMIC Motion Control GmbH & Co. KG does not authorize or warrant any of its products for use in life support systems, without the specific written consent of TRINAMIC Motion Control GmbH & Co. KG. Life support systems are equipment intended to support or sustain life, and whose failure to perform, when properly used in accordance with instructions provided, can be reasonably expected to result in personal injury or death.

Information given in this data sheet is believed to be accurate and reliable. However, no responsibility is assumed for the consequences of its use nor for any infringement of patents or other rights of third parties which may result from its use.

Specifications are subject to change without notice.

All trademarks used are property of their respective owners.

15 ESD Sensitive Device

The TMC6200 is an ESD sensitive CMOS device sensitive to electrostatic discharge. Take special care to use adequate grounding of personnel and machines in manual handling. After soldering the devices to the board, ESD requirements are more relaxed. Failure to do so can result in defect or decreased reliability.



16 Designed for Sustainability

Sustainable growth is one of the most important and urgent challenges today. We at Trinamic try to contribute by designing highly efficient IC products, to minimize energy consumption, ensure best customer experience and long-term satisfaction by smooth and silent run, while minimizing the demand for external resources like power supply, cooling infrastructure, reduced motor size and magnet material by intelligent control interfaces and advanced algorithms.

Please help and design efficient and durable products made for a sustainable world.

17 Table of Figures

FIGURE 1.1 STANDALONE APPLICATION USING DIFFERENTIAL SENSING.....	4
FIGURE 1.2 STANDALONE APPLICATION USING SINGLE SHUNT CURRENT SENSING.....	5
FIGURE 1.3 SPI MODE CONFIGURATION.....	5
FIGURE 2.1 TMC6200-TA PINNING TQFP-EP 48 (7X7MM ² BODY, 9X9MM ² WITH LEADS).....	7
FIGURE 3.1 STANDARD APPLICATION CIRCUIT.....	10
FIGURE 3.2 EXTERNAL GATE VOLTAGE SUPPLY.....	11
FIGURE 3.3 STANDBY SWITCH.....	12
FIGURE 3.4 MILLER CHARGE DETERMINES SWITCHING SLOPE.....	13
FIGURE 3.5 SLOPES, MILLER PLATEAU AND BLANK TIME (BMX=U V OR W OUTPUT).....	14
FIGURE 3.6 BRIDGE PROTECTION OPTIONS FOR POWER ROUTING INDUCTIVITY.....	15
FIGURE 3.7 RINGING OF OUTPUT (GREEN) AND GATE VOLTAGES (YELLOW, BLUE) WITH DRVSTRENGTH=0.....	16
FIGURE 3.8 RINGING OF OUTPUT (GREEN) AND GATE VOLTAGES (YELLOW, BLUE) WITH DRVSTRENGTH=2.....	16
FIGURE 3.9 RINGING OF OUTPUT (GREEN) AND GATE VOLTAGES (YELLOW, BLUE) WITH DRVSTRENGTH=3.....	16
FIGURE 3.10 DIODES FOR SAFE OFF CONDITION WITH HIGH GATE SERIES RESISTANCE.....	17
FIGURE 4.1 SPI TIMING.....	20
FIGURE 6.1 PRINCIPLE OF SENSE AMPLIFIER.....	27
FIGURE 6.2 AMPLIFIER SETTLING AFTER COIL SWITCH EVENT (GREEN: COIL OUTPUT, YELLOW: AMPLIFIER OUTPUT).....	28
FIGURE 6.3 OUTPUT CORRECTLY SAMPLED WITH SINE WAVE CURRENT AND 1.66V OFFSET.....	28
FIGURE 6.4 RANDOM OUTPUT OFFSET AT 20X AMPLIFICATION (YELLOW: OUTPUT, BLUE: VOFS INPUT).....	29
FIGURE 6.5 EXAMPLE FOR THERMAL OFFSET DRIFT AT OUTPUT (5X AMPLIFICATION) [MV] FROM 30°C TO 120°C.....	30
FIGURE 7.1 SHORT DETECTION (U, V OR W OUTPUT).....	33
FIGURE 12.1 LAYOUT EXAMPLE.....	43
FIGURE 13.1 DIMENSIONAL DRAWINGS TQFP48-EP.....	44

18 Revision History

Version	Date	Author	Description
V0.05	2018-APR-22	BD <small>BD= Bernhard Dwersteg</small>	First version of datasheet based on datasheet TMC6200 V1.0
V0.1	2018-APR-30	BD	First complete version based on preliminary data
V0.11	2018-MAY-09	BD	Offset voltage added to description, added Eval board schematics
V0.12	2018-MAY-29	BD	Minor changes
V0.13	2018-SEP-11	BD	P12VOUT Mnemonic in abs. max. table, tables back to 0.25pt lines
V1.00	2018-OKT-30	BD	Adapted electrical characteristics
V1.01	2018-NOV-15	BD	Reworked schematic showing additional protection components, added chapter on wiring bridge supply
V1.02	2019-JAN-31	BD	Characterized and documented thermal drift of sense amplifier offset, added chapter 6.2, re-specification for external clock
V1.03	2019-FEB-13	BD	Added example for offset compensation. Added Standby example
V1.04	2019-AUG-08	BD	Added ordering codes, changed block diagram
V1.05	2019-NOV-12	BD	Minor changes
V1.06	2020-JUN-10	BD	Updated logo
V1.07	2022-FEB-02	BD	Updated logo and order codes; minor wording; P15: added position of VCP capacitor for clarity
V1.08	2022-JUN-01	BD	P18: Corrected description in access example

Table 18.1 Document Revisions

Looking for pricing, stock, or lifecycle information?

Click below to explore more details on WIN SOURCE:

 [View TPD1E05U06DYAR on WIN SOURCE](#)

 [Texas Instruments](#) Information

Optimize Your Supply Chain with WIN SOURCE Solutions

-  Global Sourcing Solution
-  Obsolete Management
-  Cost Control Management
-  Shortage Management
-  Alternative Solution
-  Excess Inventory Management