



**THE DATASHEET OF
SN74LV541ARKSR**



Datasheet – STS4x

4th Generation, High-Accuracy, Ultra-Low-Power, 16-bit Temperature Sensor Platform

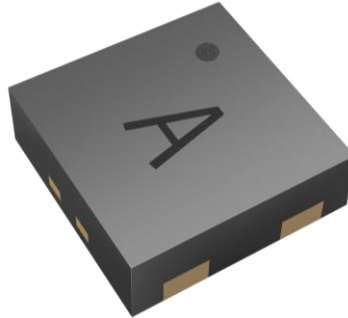

Highlights

- Temperature accuracy: up to $\pm 0.2\text{ }^{\circ}\text{C}$
- Supply voltage: 1.08 V ... 3.6 V
- Average current: 0.4 μA (at meas. rate 1 Hz)
- Idle current: 80 nA
- I²C fast mode plus, CRC checksum
- Available with multiple I2C addresses
- Operating range: -40...125 $^{\circ}\text{C}$
- NIST traceability
- JEDEC JESD47 qualification
- Mature technology from global market leader

The STS4x is a fully digital temperature sensor platform offering different accuracy classes. The I²C interface provides multiple preconfigured I²C addresses and enables an ultra-low power budget. Designed to cost, this four-pin dual-flat-no-leads package is suitable for surface mount technology (SMT) processing.

Device Overview

Product	Details
STS4L-xD1B	0.4 $^{\circ}\text{C}$ T accur., possible I2C addr.: 0x44, 0x45, 0x46.
STS40-xD1B	0.2 $^{\circ}\text{C}$ T accur., possible I2C addr.: 0x44, 0x45, 0x46..
STS41-xD1B	best T accur., possible I2C addr.: 0x44, 0x45, 0x46., coming soon

See full product list on page 13.

Functional Block Diagram

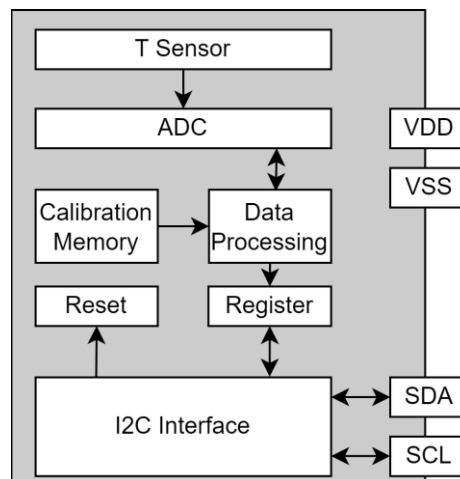

Contents

1	Quick Start – Hello World.....	3
2	Sensor Performance	4
3	Electrical Specifications	5
3.1	Electrical Characteristics	5
3.2	Timings.....	6
3.3	Absolute Maximum Ratings.....	6
4	Sensor Operation.....	7
4.1	I2C Communication.....	7
4.2	Data Type & Length.....	7
4.3	Checksum Calculation	7
4.4	Command Overview.....	8
4.5	Conversion of Signal Output	8
4.6	Serial Number.....	8
4.7	Reset & Abort.....	8
5	Physical Specification	9
5.1	Package Description.....	9
5.2	Package Outline.....	9
5.3	Land Pattern	10
5.4	Pin Assignment & Laser Marking	10
6	Quality and Material Contents	10
7	Tape and Reel Packaging	11
8	Nomenclature	12
9	Ordering Information.....	13
10	Revision History.....	14

1 Quick Start – Hello World

Figure 1 shows a typical application circuit for the STS4x on the left-hand side. After reaching the minimal supply voltage and allowing for the maximal power-up time of 1 ms, the sensor is ready for I²C communication. The quickest way to measure temperature is pseudo-coded on the right-hand side of Figure 1. Using the conversion formulae given in equations (1) and (2), the digital signal can be translated into temperature readings.

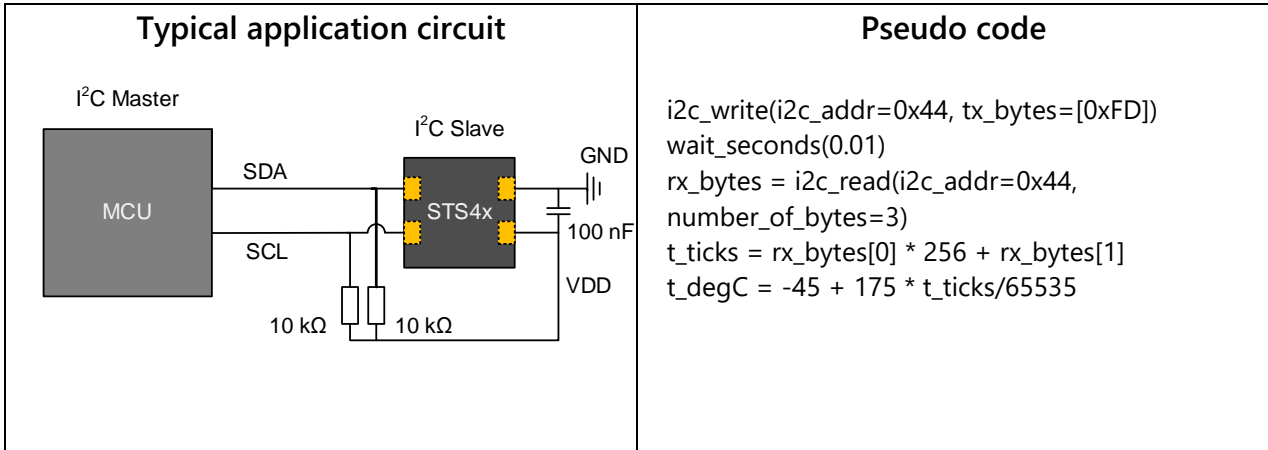

Figure 1. Typical application circuit (left) and pseudo code (right) for easy startup.

For Code resources, embedded drivers, and CAD files, please refer to the SHT4x files available on GitHub and SnapEDA.



2 Sensor Performance

Parameter	Conditions	Value	Units
STS4L T Accuracy ¹	typ.	±0.4	°C
	max.	see Figure 2	-
STS40 T Accuracy ¹	typ.	±0.2	°C
	max.	See Figure 3	-
STS41 T Accuracy ¹	typ.	±0.2	°C
	max.	see Figure 4	-
Repeatability ²	high	0.04	°C
	medium	0.07	°C
	low	0.1	°C
Resolution ³	-	0.01	°C
Specified range ⁴	-	-40 to +125	°C
Response time ⁵	$t_{63\%}$	2	s
Long-term drift ⁶	typ.	<0.03	°C/y

Table 1. General temperature sensor specifications.

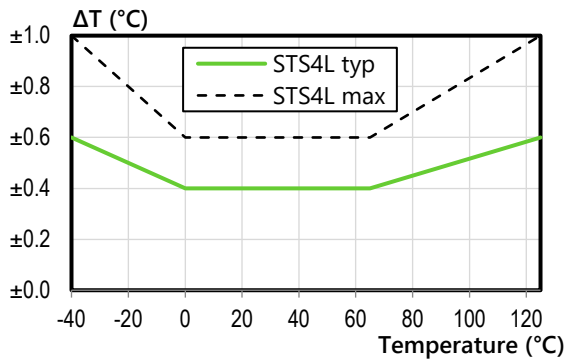

Figure 2. STS4L typical and maximal temperature accuracy.

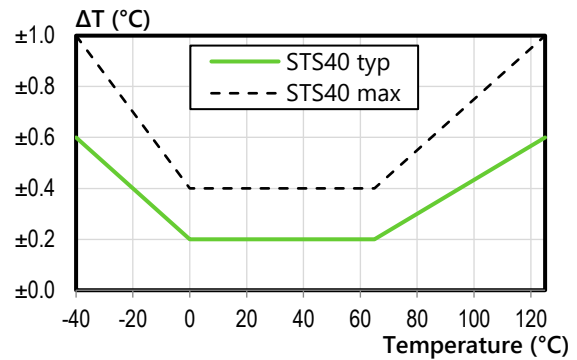

Figure 3. STS40 typical and maximal temperature accuracy.

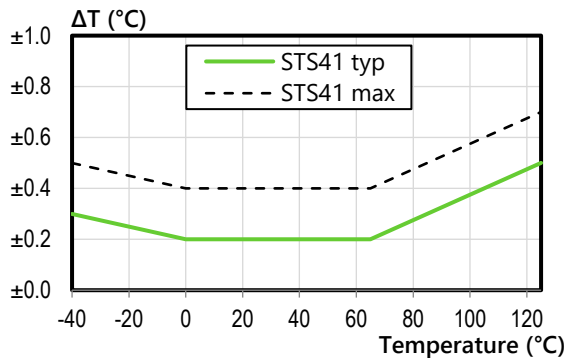

Figure 4. STS41 typical and maximal temperature accuracy.

¹ For definition of typ. and max. accuracy, please refer to the document “Sensirion Humidity Sensor Specification Statement”.

² The stated repeatability is 3 times the standard deviation (3σ) of multiple consecutive measurement values at constant conditions and is a measure for the noise on the physical sensor output. Different repeatability commands are listed in Table 6.

³ Resolution of A/D converter.

⁴ Specified range refers to the range for which the temperature sensor specification is guaranteed.

⁵ Depends on heat conductivity of sensor substrate and design-in of sensor in application.

⁶ Max. value is < 0.04°C/y.

3 Electrical Specifications

Valid for all electrical specifications: Typical values correspond to $V_{DD} = 3.3\text{ V}$ and $T = 25\text{ °C}$. Min. and max. values are valid in the full temperature range $-40\text{ °C} \dots 125\text{ °C}$ and at declared V_{DD} levels.

3.1 Electrical Characteristics

Parameter	Symbol	Conditions	Min	Typ.	Max	Units	Comments
Supply voltage	V_{DD}		1.08	3.3	3.6	V	-
Power-up/down level	V_{POR}	Static power supply	0.6	-	1.08	V	-
Supply current	I_{DD}	Idle state	-	0.08	1.0 3.4	μA	At 25°C At 125°C
		Power-up	-	50	-	μA	-
		Measurement	-	320	500	μA	Average current consumption while sensor is measuring
		Aver., high repeatability Aver., med. repeatability Aver., low repeatability	- - -	2.2 1.2 0.4	- - -	μA	Aver. current consumpt. (contin. operation with 1 meas. per second)
Power consumpt. at $V_{DD}=1.2\text{V}$	-	Aver., high repeatability Aver., med. repeatability Aver., low repeatability	- - -	2.6 1.4 0.5	- - -	μW	Aver. power consumpt. (contin. operation with one meas. per second)
Low level input voltage	V_{IL}	-	0	-	0.3* V_{DD}	V	-
High level input voltage	V_{IH}	-	0.7* V_{DD}	-	V_{DD}	V	-
Pull up resistors	R_p	$V_{DD} < 1.62\text{ V}$	820	-	-	Ω	-
		$V_{DD} \geq 1.62\text{ V}$	390	-	-	Ω	-
Low level output voltage	V_{OL}	$V_{DD} < 1.62\text{V}$, $R_{pullup} > 820\ \Omega$	-	-	0.2* V_{DD}	V	-
		$V_{DD} = 1.62\text{V} \dots 2.0\text{V}$, $R_{pullup} > 390\ \Omega$	-	-	0.2* V_{DD}	V	-
		$V_{DD} > 2.0\text{V}$, $R_{pullup} > 390\ \Omega$	-	-	0.4	V	-
Cap bus load	C_b	$R_p \leq 820\ \Omega$: fast mode	-	-	400	pF	Capac. bus load can be determined from $C_b < t_{rise}/(0.8473 \cdot R_p)$. Rise times are $t_{rise} = 300\text{ ns}$ for fast mode and $t_{rise} = 120\text{ ns}$ for fast mode plus
		$R_p = 390\ \Omega$, $V_{DD} > 1.62\text{ V}$: fast mode plus	-	-	340	pF	

Table 2. Electrical specifications.

3.2 Timings

Max. values are measured at -40°C and 1.08 V supply voltage (based on characterization).

Parameter	Symbol	Conditions	Min.	Typ.	Max.	Units	Comments
Power-up time	t_{PU}	After hard reset, $V_{DD} \geq V_{POR}$	-	0.3	1	ms	Time between V_{DD} reaching V_{POR} and sensor entering idle state
Soft reset time	t_{SR}	After soft reset	-	-	1	ms	Time between ACK of soft reset command and sensor entering idle state. Also valid for I ² C general call reset.
Waiting time	t_W	between I ² C commands	1	-	-	ms	minimal waiting time for I ² C communication
Measurement duration	$t_{MEAS,l}$	Low repeatability	-	1.3	1.6	ms	The three repeatability modes differ with respect to measurement duration, noise level and energy consumption
	$t_{MEAS,m}$	Med. repeatability	-	3.7	4.5	ms	
	$t_{MEAS,h}$	High repeatability	-	6.9	8.3	ms	

Table 3. System timing specifications.

3.3 Absolute Maximum Ratings

Stress levels beyond those listed in **Table 4** may cause permanent damage or affect the reliability of the device. Kindly note that the reported values are stress ratings only, implying that functional operation of the device under these conditions is not guaranteed. Ratings are only tested separately.

Parameter	Rating
Max. voltage on any pin	$V_{SS} - 0.3 \text{ V} \dots V_{DD} + 0.3 \text{ V}$
Operating temperature range	-40 °C ... 125 °C
Storage temperature range	-40 °C ... 150 °C
ESD HBM	2 kV
ESD CDM	500 V
Latch up, JEDEC Class II, 125°C	+/-100 mA

Table 4. Absolute maximum ratings.

4 Sensor Operation

4.1 I²C Communication

I²C communication is based on NXP’s I²C-bus specification and user manual UM10204, Rev.6, 4 April 2014. Supported I²C modes are standard, fast mode, and fast mode plus. Data is transferred in multiples of 16-bit words and an 8-bit check sum (cyclic redundancy check = CRC). All transfers must begin with a start condition (S) and terminate with a stop condition (P). To finish a read transfer, send not acknowledge (NACK) and stop condition (P). Addressing a specific slave device is done by sending its 7-bit I²C address followed by an eighth bit, denoting the communication direction: “zero” indicates transmission to the slave, i.e. “write”, a “one” indicates a “read” request. Schematics of the I²C transfer types are sketched in Figure 5.

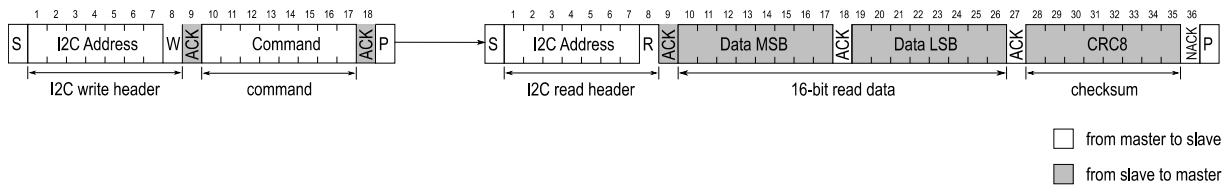

Figure 5. I²C transfer types: First a write header is sent to the I²C slave, followed by a command, for example “measure T with highest precision”. After the measurement is finished the read request directed to this I²C slave will be acknowledged and transmission of data will be started by the slave. The I²C address is defined by Sensirion and selectable by choosing from a selection of 0x44, 0x45, or 0x46 before ordering. For ordering details, kindly refer to section 8 and 9.

4.2 Data Type & Length

The I²C bus operates with 8-bit data packages. Information from the sensor to the master has a checksum after every second 8-bit data package. Therefore, the temperature data will always be transmitted in the following way (2 * 8-bit data + 8-bit CRC).

4.3 Checksum Calculation

For read transfers each 16-bit data is followed by a checksum with the following properties

Property	Value
Name	CRC-8
Message Length	16-bit
Polynomial	0x31 ($x^8 + x^5 + x^4 + 1$)
Initialization	0xFF
Reflect Input/Output	false/false
Final XOR	0x00
Examples	CRC(0xBEEF) = 0x92

Table 5. Data check sum properties.

The master may abort a read transfer after the 16-bit data, if it does not require a checksum.

4.4 Command Overview

Command		Response length incl. CRC (bytes)	Description
bin	hex		
1111 1101	FD	3	measure T with high precision (high repeatability) [2 * 8-bit T-data; 8-bit CRC]
1111 0110	F6	3	measure T with medium precision (medium repeatability) [2 * 8-bit T-data; 8-bit CRC]
1110 0000	E0	3	measure T with lowest precision (low repeatability) [2 * 8-bit T-data; 8-bit CRC]
1000 1001	89	6	read serial [2 * 8-bit data; 8-bit CRC; 2 * 8-bit data; 8-bit CRC]
1001 0100	94	-	soft reset [ACK]

Table 6. Overview of I²C commands. If the sensor is not ready to process a command, e.g. because it is still measuring, it will response with NACK to the I2C read header.

4.5 Conversion of Signal Output

The digital sensor signal S_T corresponds to temperatures, as described in Eqs. (1), and (2).

$$T = \left(-45 + 175 \cdot \frac{S_T}{2^{16}-1}\right) ^\circ\text{C} \tag{1}$$

$$T = \left(-49 + 315 \cdot \frac{S_T}{2^{16}-1}\right) ^\circ\text{F} \tag{2}$$

4.6 Serial Number

Each sensor has a unique serial number that is assigned by Sensirion during production. It is stored in the one-time-programmable memory and cannot be manipulated after production. The serial number is accessible via I²C and is transmitted as two 16-bit words, each followed by an 8-bit CRC.

4.7 Reset & Abort

A reset of the sensor can be achieved in three ways:

1. Soft reset: send the reset command described in **Table 6**.
2. I²C general call: all devices on the I²C bus are reset by sending the command 0x06 to the I²C address 0x00.
3. Power down (incl. pulling SCL and SDA low)

Any command that triggers an action at the sensor can be aborted *via* I²C general call reset or soft reset.

5 Physical Specification

5.1 Package Description

The STS4x is provided in a dual flat no lead (DFN) package, and comprises the sensor chip made of silicon, which is hosted on a copper leadframe and overmolded by an epoxy-based mold compound. The exposed bottom side of the leadframe with the metallic contacts is Sn plated, while the side walls are bare copper. While moisture sensitivity level (MSL) 1 according to IPC/JEDEC J-STD-020 is met, we recommend to process the sensors within one year after date of delivery.

5.2 Package Outline

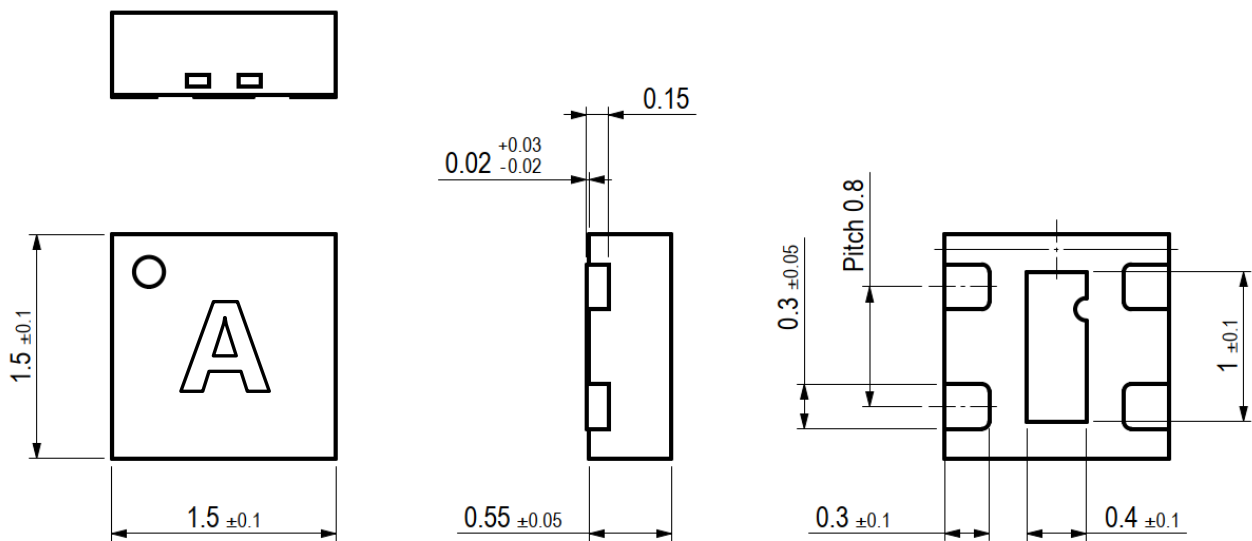

Figure 6. Dimensional drawing of the STS4x including package tolerances (units mm). The Pin 1 is identified by the laser dot on the top side and the cutout of the die pad, visible from the bottom. In the middle of the DFN top side, a lasered character ("A", "B", or "C") indicates the I2C address as detailed in Tables 7 and 8.

5.3 Land Pattern

We recommend designing the land pattern to the used PCB and soldering process together with the physical outer dimensions of the sensor. For reference, the land pattern used with Sensirion’s PCBs and soldering processes is given in **Figure 7**.

Soldering of the central die pad is optional.

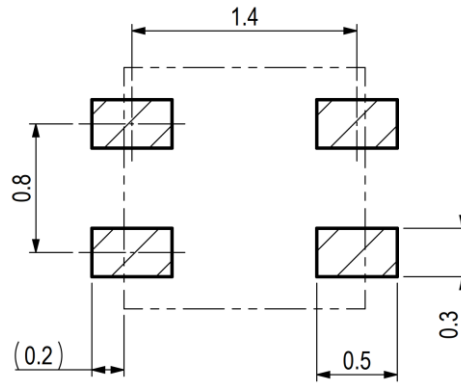

Figure 7. Recommended land pattern (in mm). Details can vary and depend on used PCBs and solder processes. There shall be no copper under the sensor other than at the pin pads.

5.4 Pin Assignment & Laser Marking

Pin	Name	Comments
1	SDA	Serial data, bidirectional
2	SCL	Serial clock, unidirectional input
3	VDD	Supply voltage
4	VSS	Ground

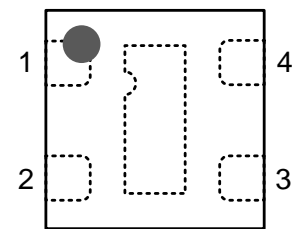

Figure 8. Pin assignment (transparent top view). Dashed lines are only visible if sensor is viewed from below. The die pad is not directly connected to any pin. Pin-1 is indicated by the cutout of the die pad from the bottom side (see dashed lines) and the top side laser marking (dot in upper left corner).

6 Quality and Material Contents

Qualification of STS4x is performed based on the JEDEC JESD47 qualification test method (currently pending). The device is fully RoHS and WEEE compliant, *e.g.* free of Pb, Cd, and Hg.

7 Tape and Reel Packaging

All specifications for the tape and reel packaging can be found in **Figure 9**. The reel diameter for the 10k packaging is 13 inches.

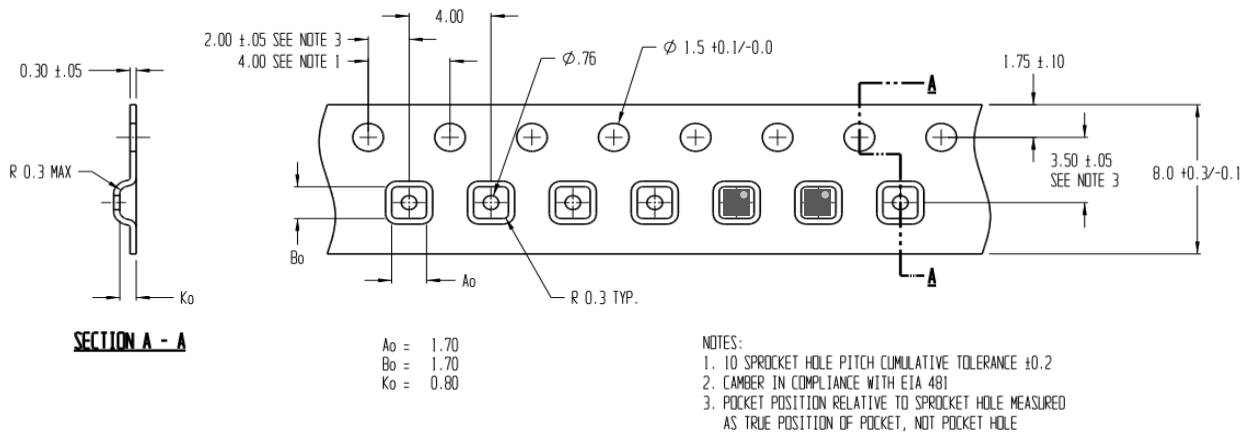

Figure 9. Tape and reel specifications including a depiction of two sensors in their corresponding pockets. In this orientation, Pin 1 is in the upper right corner, as indicated by the dot on the sensor and in the drawing.

In contrast to other products from the SHT4x line, the STS4x features shortened reel numbers for efficiency, as not all digits present for the SHT4x family (ZZZZZ) would be used for the STS4x family.

Kindly note the differences described below:

SHT4x: YYZZZZSSSSSSNNNNNN
 (YY: Year, SSSSSS: material number, NNNNNN: reel code)

STS4x: YYSSSSSSNNNNNN
 (YY: Year, SSSSSS: material number, NNNNNN: reel code)

8 Nomenclature

Position	Value	Explanation
1	S	Sensirion
2	T	Temperature
3	S	Sensor
4	4	Fourth product generation
5	L	0.4°C T accuracy
	0	0.2°C T accuracy
	1	Improved 0.2°C T accuracy
6	-	delimiter
7	A	I ² C interface with 0x44 address
	B	I ² C interface with 0x45 address
	C	I ² C interface with 0x46 address
8	D	DFN package
9	1	reserved
10	B	reserved
11	-	delimiter
12	R	Tape on reel packaging
13	3	Packaging article contains 10'000 pieces

Table 7. STS4x product nomenclature.

9 Ordering Information

Material Description	Material Number	Details	Quantity (pcs)
STS4L-AD1B-R3	3.001.160	base T accuracy, 0x44 I ² C addr., Lasermarking "A"	10'000
STS4L-BD1B-R3	3.001.161	base T accuracy, 0x45 I ² C addr. Lasermarking "B"	10'000
STS4L-CD1B-R3	3.001.162	base T accuracy, 0x46 I ² C addr. Lasermarking "C"	10'000
STS40-AD1B-R3	3.000.781	intermediate T accuracy, 0x44 I ² C addr., Lasermarking "A"	10'000
STS40-BD1B-R3	3.000.782	intermediate T accuracy, 0x45 I ² C addr. Lasermarking "B"	10'000
STS40-CD1B-R3	3.000.780	intermediate T accuracy, 0x46 I ² C addr. Lasermarking "C"	10'000
STS41-AD1B-R3	tbd	best T accuracy, 0x44 I ² C addr., Lasermarking "A", coming soon	10'000
STS41-BD1B-R3	tbd	best T accuracy, 0x45 I ² C addr. Lasermarking "B", coming soon	10'000
STS41-CD1B-R3	tbd	best T accuracy, 0x46 I ² C addr. Lasermarking "C", coming soon	10'000

Table 8. STS4x ordering options.

10 Revision History

Date	Version	Page(s)	Changes
November 2020	0.1	all	Initial release, preliminary version.
June 2021	0.2	1, 11	Updated ordering options.
February 2022	1	1, 7, 11, 12 9, 10 9 1	Updated ordering and I2C address options. Updated laser marking description. Corrected typo in package outline. Added functional block diagram.
July 2022	1.1	12 12	Updated reel numbers and description. Updated ordering numbers.
June 2023	1.2	1, 10, 13 2	Added laser marking I2C address indicator Updated SnapEDA link
September 2023	2	1, 10	Rendering on page one and Fig 4. on page 10: I2C address indicator position and size change
June 2024	3	all	New STS4L and STS41 Sensors released

Important Notices

Warning, Personal Injury

Do not use this product as safety or emergency stop devices or in any other application where failure of the product could result in personal injury. Do not use this product for applications other than its intended and authorized use. Before installing, handling, using or servicing this product, please consult the data sheet and application notes. Failure to comply with these instructions could result in death or serious injury.

If the Buyer shall purchase or use SENSIRION products for any unintended or unauthorized application, Buyer shall defend, indemnify and hold harmless SENSIRION and its officers, employees, subsidiaries, affiliates and distributors against all claims, costs, damages and expenses, and reasonable attorney fees arising out of, directly or indirectly, any claim of personal injury or death associated with such unintended or unauthorized use, even if SENSIRION shall be allegedly negligent with respect to the design or the manufacture of the product.

ESD Precautions

The inherent design of this component causes it to be sensitive to electrostatic discharge (ESD). To prevent ESD-induced damage and/or degradation, take customary and statutory ESD precautions when handling this product. See application note "ESD, Latchup and EMC" for more information.

Warranty

SENSIRION warrants solely to the original purchaser of this product for a period of 12 months (one year) from the date of delivery that this product shall be of the quality, material and workmanship defined in SENSIRION's published specifications of the product. Within such period, if proven to be defective, SENSIRION shall repair and/or replace this product, in SENSIRION's discretion, free of charge to the Buyer, provided that:

- notice in writing describing the defects shall be given to SENSIRION within fourteen (14) days after their appearance;
- such defects shall be found, to SENSIRION's reasonable satisfaction, to have arisen from SENSIRION's faulty design, material, or workmanship;
- the defective product shall be returned to SENSIRION's factory at the Buyer's expense; and
- the warranty period for any repaired or replaced product shall be limited to the unexpired portion of the original period.

This warranty does not apply to any equipment which has not been installed and used within the specifications recommended by SENSIRION for the intended and proper use of the equipment. EXCEPT FOR THE WARRANTIES EXPRESSLY SET FORTH HEREIN, SENSIRION MAKES NO WARRANTIES, EITHER EXPRESS OR IMPLIED, WITH RESPECT TO THE PRODUCT. ANY AND ALL WARRANTIES, INCLUDING WITHOUT LIMITATION, WARRANTIES OF MERCHANTABILITY OR FITNESS FOR A PARTICULAR PURPOSE, ARE EXPRESSLY EXCLUDED AND DECLINED.

SENSIRION is only liable for defects of this product arising under the conditions of operation provided for in the data sheet and proper use of the goods. SENSIRION explicitly disclaims all warranties, express or implied, for any period during which the goods are operated or stored not in accordance with the technical specifications.

SENSIRION does not assume any liability arising out of any application or use of any product or circuit and specifically disclaims any and all liability, including without limitation consequential or incidental damages. All operating parameters, including without limitation recommended parameters, must be validated for each customer's applications by customer's technical experts. Recommended parameters can and do vary in different applications.

SENSIRION reserves the right, without further notice, (i) to change the product specifications and/or the information in this document and (ii) to improve reliability, functions and design of this product.

Headquarters and Subsidiaries

Sensirion AG

Laubisruetistr. 50
CH-8712 Staefa ZH
Switzerland

phone: +41 44 306 40 00
fax: +41 44 306 40 30
info@sensirion.com
www.sensirion.com

Sensirion Taiwan Co. Ltd

phone: +886 2 2218-6779
info@sensirion.com
www.sensirion.com

Sensirion Inc., USA

phone: +1 312 690 5858
info-us@sensirion.com
www.sensirion.com

Sensirion Japan Co. Ltd.

phone: +81 45 270 4506
info-jp@sensirion.com
www.sensirion.com/jp

Sensirion Korea Co. Ltd.

phone: +82 31 337 7700~3
info-kr@sensirion.com
www.sensirion.com/kr

Sensirion China Co. Ltd.

phone: +86 755 8252 1501
info-cn@sensirion.com
www.sensirion.com/cn

To find your local representative, please visit
www.sensirion.com/distributors

Looking for pricing, stock, or lifecycle information?

Click below to explore more details on WIN SOURCE:

 [View SN74LV541ARKSR on WIN SOURCE](#)

 [Texas Instruments](#) Information

Optimize Your Supply Chain with WIN SOURCE Solutions

-  Global Sourcing Solution
-  Obsolete Management
-  Cost Control Management
-  Shortage Management
-  Alternative Solution
-  Excess Inventory Management