



**THE DATASHEET OF  
PCSA1-S5-S12-S**



## ASYMMETRICAL BIDIRECTIONAL THYRISTOR SPD

TISP4A270H3BJ LCAS R<sub>LINE</sub> ProtectorOptimized LCAS R<sub>LINE</sub> Protector

TISP4A270H3BJ V<sub>(BO)</sub> Derived from:  
 -Break Switch, SW1 & SW2, Ratings  
 -Ring Return Switch, SW3, Rating  
 -Ringing Access Switch, SW4, Rating  
 -Switch Isolation Ratings  
 -Battery Voltage Range of -40 V to -60 V  
 -Power Fault Conditions  
 -Lightning Impulse Conditions  
 -LCAS Characteristic Temperature Range

TISP4A270H3BJ Designed for:  
 -Battery-Backed Ringing Circuits  
 Voltage Swing..... +148 V to -206 V  
 Allows  
 ...103 V rms Ringing with -60 V Battery  
 Temperature Range  
 ..... -40 °C to +85 °C

Device	V <sub>DRM</sub> V	V <sub>(BO)</sub> V
'4A270	+160	+217
	-222	-270

## Rated for International Surge Wave Shapes

Wave Shape	Standard	I <sub>PPSM</sub> A
2/10 μs	GR-1089-CORE	500
10/700 μs	ITU-T K.20/45/21	150
10/1000 μs	GR-1089-CORE	100

## SMB Package (Top View)

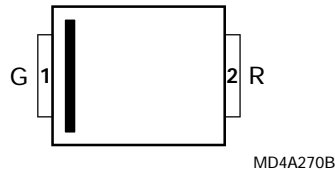

..... UL Recognized Component

## Additional Information

Click these links for more information:



## Agency Recognition

Description	
UL	File Number: <a href="#">E215609</a>

## Device Symbol and Circuit Application

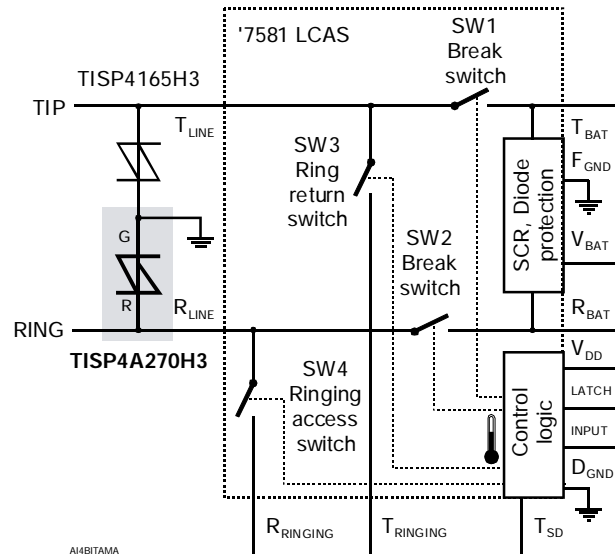

## Description

The TISP4A270H3BJ is an asymmetrical-bidirectional thyristor surge protective device (SPD). It is designed to limit the peak voltages on the R<sub>LINE</sub> (Ring Line) terminal of '7581/2/3 LCAS (Line Card Access Switch) devices. The TISP4A270H3BJ must have the bar-indexed terminal 1 (G) connected to the protective ground and terminal 2 (R) connected to the R<sub>LINE</sub> terminal.

The TISP4A270H3BJ voltages are chosen to give R<sub>LINE</sub> terminal protection for all LCAS switch conditions. The most potentially stressful condition is low level power cross when the switches are closed. Under this condition, the TISP4A270H3BJ limits the voltage and corresponding LCAS dissipation until the LCAS thermal trip operates and opens the switches.

Under open-circuit ringing conditions, the R<sub>LINE</sub> terminal will have high peak voltages. For battery backed ringing, the R<sub>LINE</sub> terminal will have a larger peak negative voltage than positive, i.e. the peak voltages are asymmetric. The TISP4A270H3BJ has a similar voltage asymmetry which will allow the maximum possible ringing voltage, while still giving protection. With a connected telephone line, the LCAS T<sub>LINE</sub> (Tip Line) terminal voltage levels will be less than 50 % of the open-circuit R<sub>LINE</sub> terminal values. So the T<sub>LINE</sub> terminal can be protected by a symmetrical-bidirectional overvoltage protector of the TISP4xxxH3BJ series.



**WARNING Cancer and Reproductive Harm**  
[www.P65Warnings.ca.gov](http://www.P65Warnings.ca.gov)

APRIL 2002 – REVISED JULY 2019

\*RoHS Directive 2015/863, Mar 31, 2015 and Annex.

Specifications are subject to change without notice.

Users should verify actual device performance in their specific applications.

The products described herein and this document are subject to specific legal disclaimers as set forth on the last page of this document, and at [www.bourns.com/docs/legal/disclaimer.pdf](http://www.bourns.com/docs/legal/disclaimer.pdf).

## Description (Continued)

These devices allow signal voltages up to the maximum off-state voltage value,  $V_{DRM}$ , see Figure 1. Voltages above  $V_{DRM}$  are clipped and will not exceed the breakover voltage,  $V_{(BO)}$ , level. If sufficient current flows due to the overvoltage, the device switches into a low-voltage on-state condition, which diverts the current from the overvoltage through the device. When the diverted current falls below the holding current,  $I_H$ , level the devices switches off and restores normal system operation.

The TISP4A270H3BJ is guaranteed to voltage limit and withstand the listed international lightning surges in both polarities. This high current protection device is in a plastic SMB package (JEDEC DO-214AA) and supplied in embossed tape reel pack.

## How to Order

Device	Package	Carrier	Order As
TISP4A270H3BJ	BJ (SMB/DO-214AA with J-Bend)	R (Embossed Tape Reeled)	TISP4A270H3BJR-S

Absolute Maximum Ratings,  $T_A = 25\text{ }^\circ\text{C}$  (Unless Otherwise Noted)

Rating	Symbol	Value	Unit
Repetitive peak off-state voltage, (see Note 1) $T_A = 25\text{ }^\circ\text{C}$ $T_A = -40\text{ }^\circ\text{C}$	$V_{DRM}$	+160/-222 148/-206	V
Non-repetitive peak on-state pulse current (see Notes 2 and 3) 2/10 (GR-1089-CORE, 2/10 voltage wave shape) 5/310 (ITU-T K.44, 10/700 $\mu\text{s}$ voltage wave shape used in K.20/45/21) 10/1000 (GR-1089-CORE, 10/1000 voltage wave shape)	$I_{PPSM}$	500 150 100	A
Non-repetitive peak on-state current (see Notes 2, 3 and 4) 20 ms (50 Hz) full sine wave 16.7 ms (60 Hz) full sine wave 1000 s 50 Hz/60 Hz a.c.	$I_{TSM}$	55 60 2.2	A
Initial rate of rise of on-state current, Exponential current ramp, Maximum ramp value < 200 A	$di_T/dt$	400	A/ $\mu\text{s}$
Junction temperature	$T_J$	-40 to +150	$^\circ\text{C}$
Storage temperature range	$T_{stg}$	-65 to +150	$^\circ\text{C}$

- NOTES: 1. See Figure 7 for voltage values at intermediate temperatures.  
 2. Initially, the TISP4A270H3BJ must be in thermal equilibrium with  $T_J = 25\text{ }^\circ\text{C}$ .  
 3. The surge may be repeated after the TISP4A270H3BJ returns to its initial conditions.  
 4. EIA/JESD51-2 environment and EIA/JESD51-3 PCB with standard footprint dimensions connected with 5 A rated printed wiring track widths. See Figure 6 for the current ratings at other durations. Derate current values at  $-0.61\text{ }^\circ\text{C}$  for ambient temperatures above  $25\text{ }^\circ\text{C}$ .

# TISP4A270H3BJ LCAS R<sub>LINE</sub> Protector

**BOURNS®**

## Overload Ratings, T<sub>A</sub> = 25 °C (Unless Otherwise Noted)

Rating	Symbol	Value	Unit
Maximum overload on-state current without open circuit, 50 Hz/60 Hz a.c. (see Note 5)	I <sub>T(OV)M</sub>	60	A rms
0.03 s		40	
0.07 s		8	
1.6 s		7	
5.0 s		2.2	
1000 s			

NOTE 5: Peak overload on-state current during a.c. power cross tests of GR-1089-CORE and UL 1950/60950. These electrical stress levels may damage the TISP4A270H3BJ silicon chip. After test, the pass criterion is either that the device is functional or, if it is faulty, that it has a short circuit fault mode. In the short circuit fault mode, the following equipment is protected as the device is a permanent short across the line. The equipment would be unprotected if an open circuit fault mode developed.

## Electrical Characteristics, T<sub>A</sub> = 25 °C (Unless Otherwise Noted)

Parameter	Test Conditions	Min	Typ	Max	Unit
I <sub>DRM</sub> Repetitive peak off-state current	V <sub>D</sub> = +100 V and -200 V T <sub>A</sub> = 25 °C T <sub>A</sub> = 85 °C			±5 ±10	μA
V <sub>(BO)</sub> Breakover voltage	dv/dt = ±250 V/ms, R <sub>SOURCE</sub> = 300 Ω			+217 -270	V
V <sub>(BO)</sub> Ramp breakover voltage	dv/dt = 1 kV/μs, Linear voltage ramp, Maximum ramp value = ±500 V dv/dt = 20 A/μs, Linear current ramp, Maximum ramp value = ±10 A			+231 -288	V
I <sub>(BO)</sub> Breakover current	dv/dt = ±250 V/ms, R <sub>SOURCE</sub> = 300 Ω	±0.15		±0.6	A
I <sub>H</sub> Holding current	I <sub>T</sub> = ±5 A, di/dt = +/-30 mA/ms	±0.15		±0.6	A
dv/dt Critical rate of rise of off-state voltage	Linear voltage ramp, Maximum ramp value < 0.85V <sub>DRM</sub>	±5			kV/μs
I <sub>D</sub> Off-state current	V <sub>D</sub> = ±50 V T <sub>A</sub> = 85 °C			±10	μA
C <sub>off</sub> Off-state capacitance	f = 1 MHz, V <sub>d</sub> = 1 V rms				pF
	V <sub>D</sub> = 100 V		21	23	
	V <sub>D</sub> = 50 V		27	29	
	V <sub>D</sub> = 10 V		41	46	
	V <sub>D</sub> = 5 V		48	53	
	V <sub>D</sub> = 2 V		56	62	
	V <sub>D</sub> = 1 V		61	67	
	V <sub>D</sub> = 0		68	74	
	V <sub>D</sub> = -1 V		62	68	
	V <sub>D</sub> = -2 V		56	62	
	V <sub>D</sub> = -5 V		48	52	
	V <sub>D</sub> = -10 V		40	45	
	V <sub>D</sub> = -50 V		25	28	
	V <sub>D</sub> = -100 V		20	22	

APRIL 2002 – REVISED JULY 2019

Specifications are subject to change without notice.

Users should verify actual device performance in their specific applications.

The products described herein and this document are subject to specific legal disclaimers as set forth on the last page of this document, and at [www.bourns.com/docs/legal/disclaimer.pdf](http://www.bourns.com/docs/legal/disclaimer.pdf).

**Thermal Characteristics**

Parameter	Test Conditions	Min	Typ	Max	Unit
R <sub>θJA</sub> Junction to free air thermal resistance	EIA/JESD51-3 PCB, I <sub>T</sub> = I <sub>TSM(1000)</sub> , T <sub>A</sub> = 25 °C, (see Note 6)			113	°C/W
	265 mm x 210 mm populated line card, 4-layer PCB, I <sub>T</sub> = I <sub>TSM(1000)</sub> , T <sub>A</sub> = 25 °C		50		

NOTE 6: EIA/JESD51-2 environment and PCB has standard footprint dimensions connected with 5 A rated printed wiring track widths.

**Parameter Measurement Information**

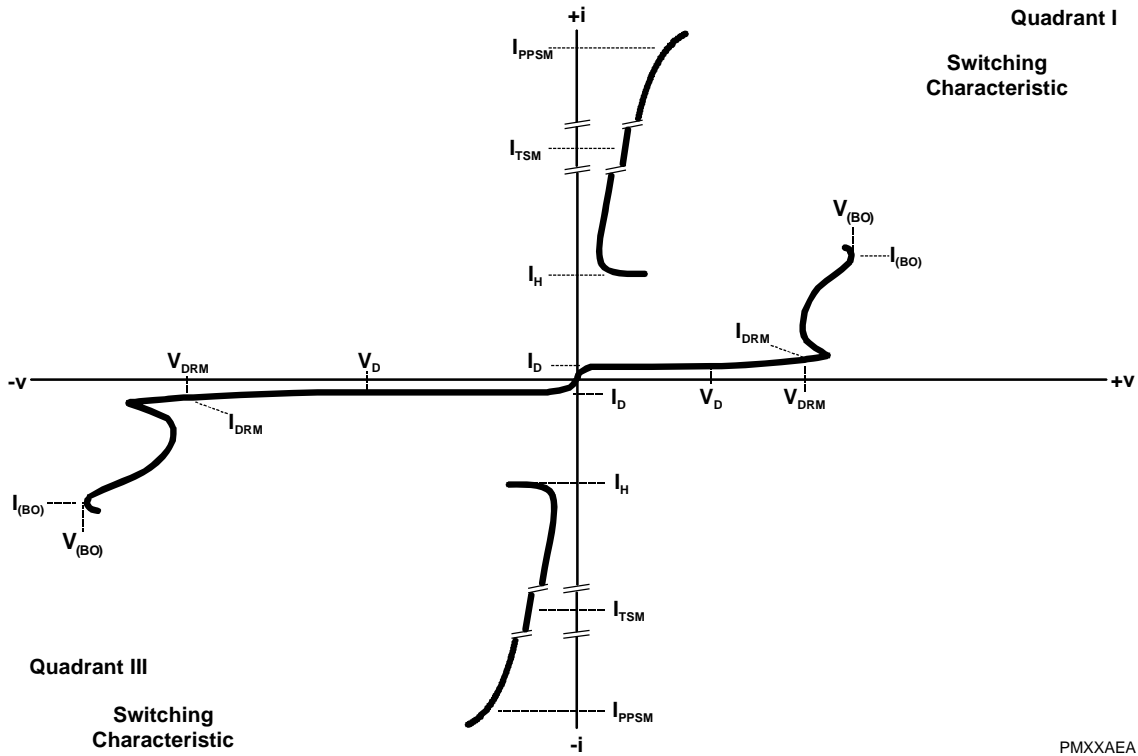

**Figure 1. Voltage-Current Characteristic for R and G Terminal Pair**  
 All Measurements are Referenced to the G Terminal

## Typical Characteristics

**OFF-STATE CURRENT  
VS  
JUNCTION TEMPERATURE**

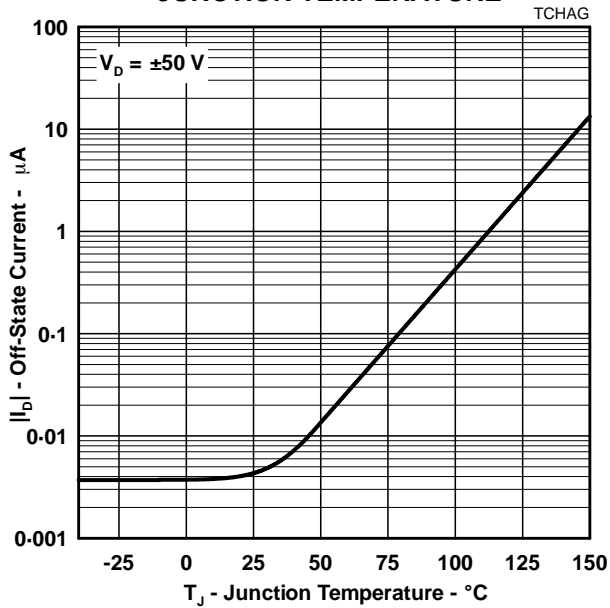

Figure 2.

**NORMALIZED BREAKOVER VOLTAGE  
VS  
JUNCTION TEMPERATURE**

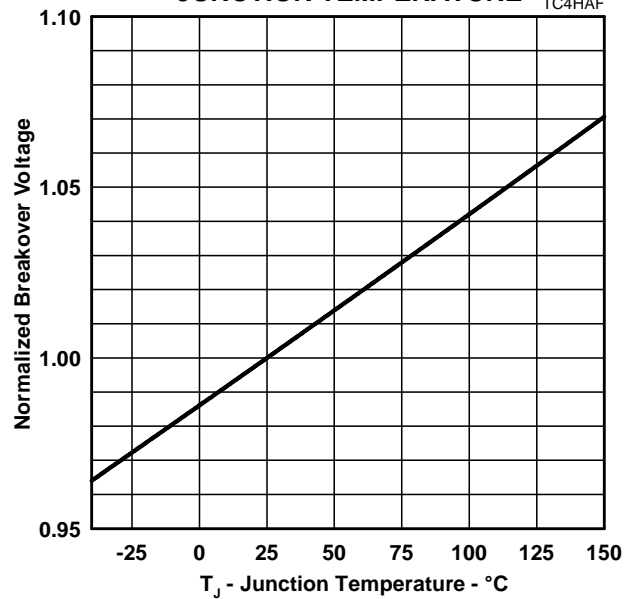

Figure 3.

**ON-STATE CURRENT  
VS  
ON-STATE VOLTAGE**

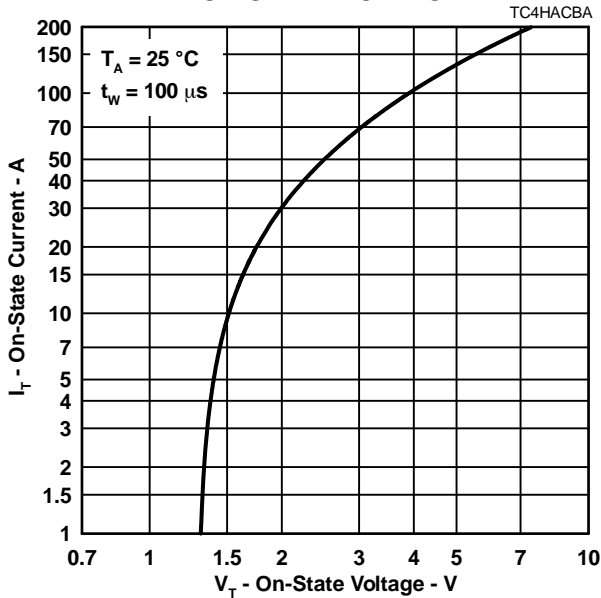

Figure 4.

**NORMALIZED HOLDING CURRENT  
VS  
JUNCTION TEMPERATURE**

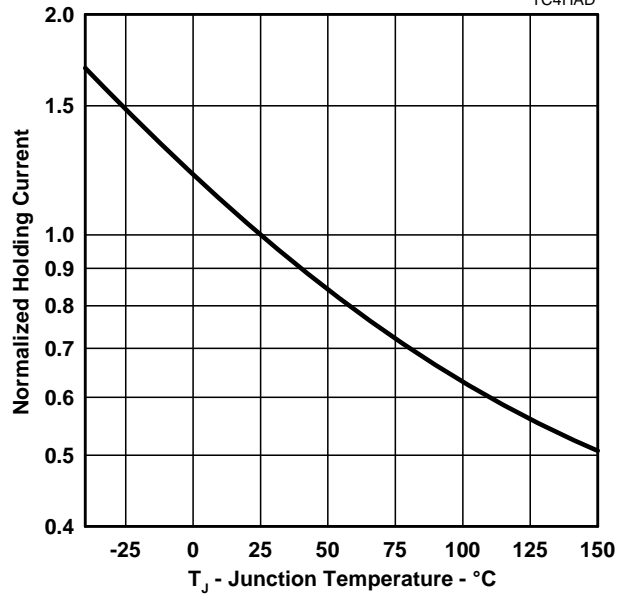

Figure 5.

APRIL 2002 – REVISED JULY 2019

Specifications are subject to change without notice.

Users should verify actual device performance in their specific applications.

The products described herein and this document are subject to specific legal disclaimers as set forth on the last page of this document, and at [www.bourns.com/docs/legal/disclaimer.pdf](http://www.bourns.com/docs/legal/disclaimer.pdf).

Rating and Thermal Information

**NON-REPETITIVE PEAK ON-STATE CURRENT  
VS  
CURRENT DURATION**

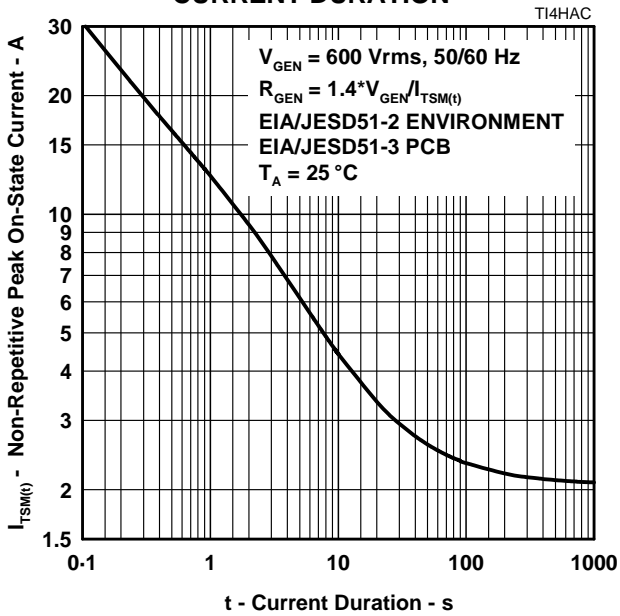

Figure 6.

**V<sub>DRM</sub> DERATING FACTOR  
VS  
MINIMUM AMBIENT TEMPERATURE**

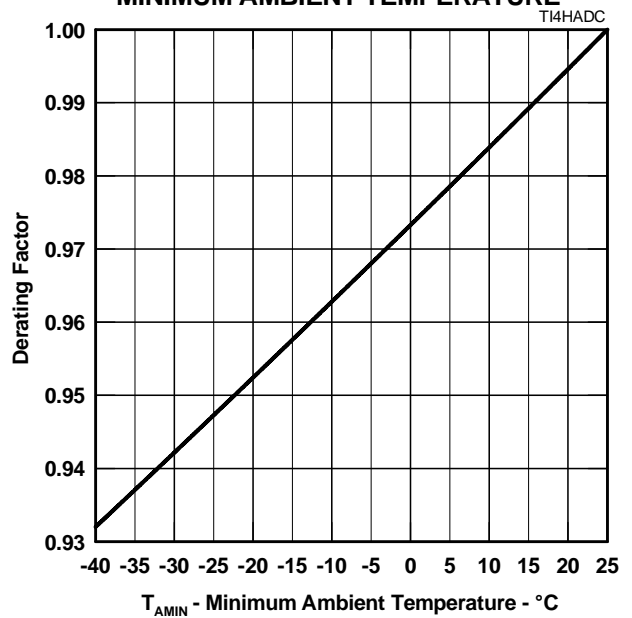
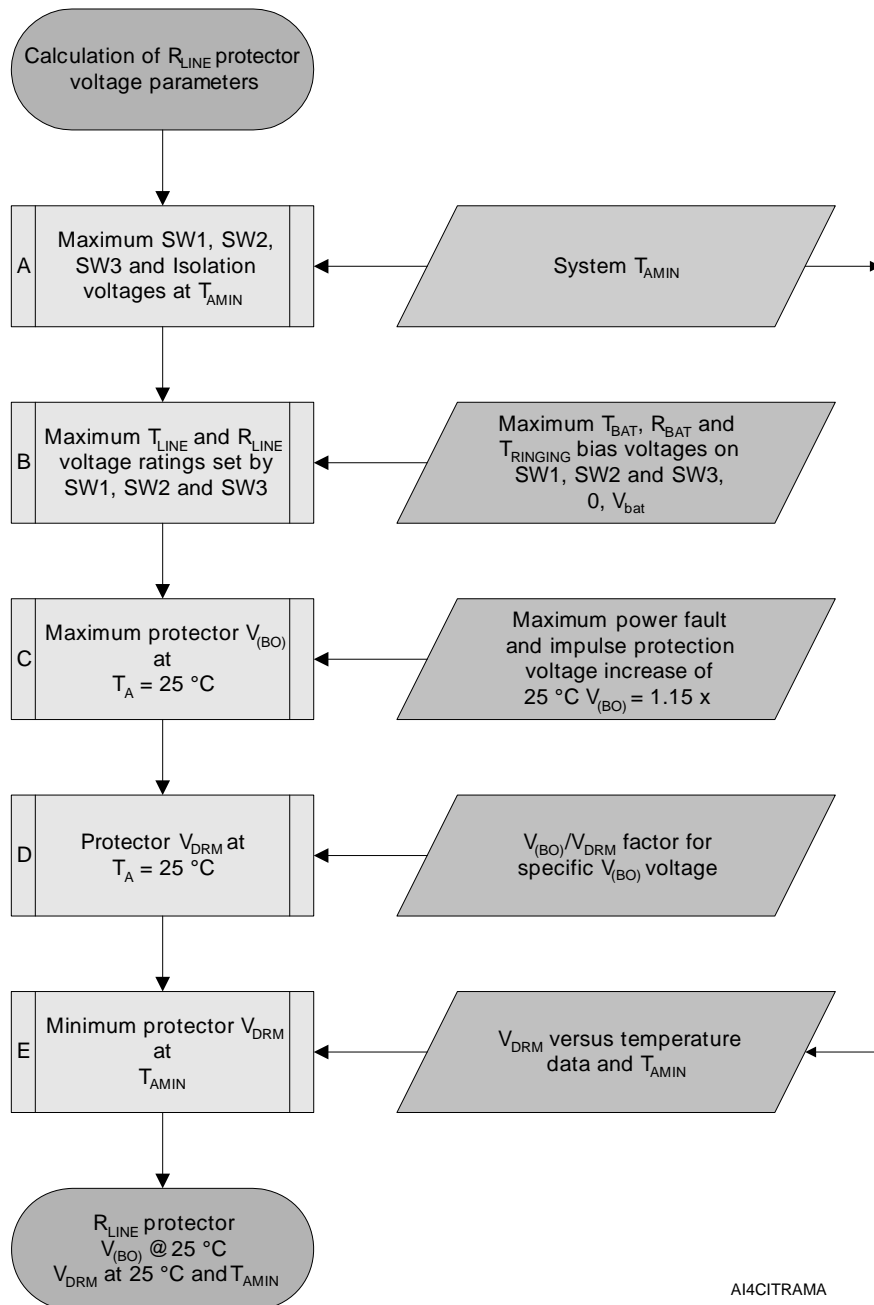

Figure 7.

## APPLICATIONS INFORMATION

### Calculation of the TISP4A270H3BJ Voltage Values

Figure 8 and the following text summarizes the derivation process for the TISP4A270H3BJ voltages. Details of the full process and other design aspects are covered by the document entitled *TISP4A270H3BJ - Optimized 758x LCAS Overvoltage Protection*.



A14CITRAMA

**Figure 8. Derivation of TISP4A270H3BJ V<sub>(BO)</sub> and V<sub>DRM</sub>**

APRIL 2002 – REVISED JULY 2019

Specifications are subject to change without notice.

Users should verify actual device performance in their specific applications.

The products described herein and this document are subject to specific legal disclaimers as set forth on the last page of this document, and at [www.bourns.com/docs/legal/disclaimer.pdf](http://www.bourns.com/docs/legal/disclaimer.pdf).

## Calculation of the TISP4A270H3BJ Voltage Values (Continued)

**Box A:** The voltage rating of the break and ring return switches and their isolation decreases with temperature. At the minimum LCAS operating temperature of -40 °C, the switch rating is  $\pm 310$  V.

**Box B:** A switch pole voltage rating to ground is reduced by any opposing bias voltage applied to the other pole. For battery-backed ringing the d.c. bias on T<sub>RINGING</sub> is zero. Bias voltages are applied to the R<sub>BAT</sub> and T<sub>BAT</sub> poles by the SLIC. For SLIC output levels of zero and -60 V, the R<sub>LINE</sub> and T<sub>LINE</sub> voltage ratings to ground become +250 V and -310 V at -40 °C.

**Box C:** Allowing for the extreme condition of a power fault at -40 °C, the overvoltage protector V<sub>(BO)</sub> at its highest temperature must not exceed +250 V and -310 V. The IEEE Standard C62.37.1-2000, *IEEE Guide for the Application of Thyristor Surge Protective Devices*, pp 25-27 recommends a factor of 1.15 for the ratio of the power fault V<sub>(BO)</sub> to the 25 °C V<sub>(BO)</sub>. Applying this factor makes the 25 °C V<sub>(BO)</sub> voltage values +217 V and -270 V.

**Box D:** From the V<sub>(BO)</sub> values the values of protector 25 °C V<sub>DRM</sub> were determined as +160 V and -222 V.

**Box E:** Derating the 25 °C V<sub>DRM</sub> down to the LCAS minimum operating temperature gives -40 °C V<sub>DRM</sub> values of +148 V and -206 V. A further rating check has to be done on the ringing access switch, SW4. The limit condition is in the negative ringing polarity. The applied ringing voltage to the R<sub>RINGING</sub> terminal must not exceed -205 V when the R<sub>LINE</sub> terminal is at +250 V. For a battery voltage of -40 V and -60 V the a.c. ringing levels must not exceed 117 V rms and 102 V rms respectively. In IVD (Integrated Voice Data) applications the a.c. ringing level must be reduced by the level of digital signal applied to the line. For a 20 V peak ADSL signal level, the ringing voltages reduce to 103 V rms and 89 V rms respectively.

Figure 9 shows a typical application circuit. Fuses F1 and F2 need high breaking capacity to safely interrupt 40 A rms (UL 60950) and 60 A rms (Telcordia GR-1089-CORE) currents from a 600 V rms source. The Bourns® Telefuse™ type B1250T is a surface mount fuse which has UL recognition for these UL and Telcordia standards. The TISP4A270H3BJ is overload rated to carry currents up to 60 A rms for the time period that it takes the fuse to operate.

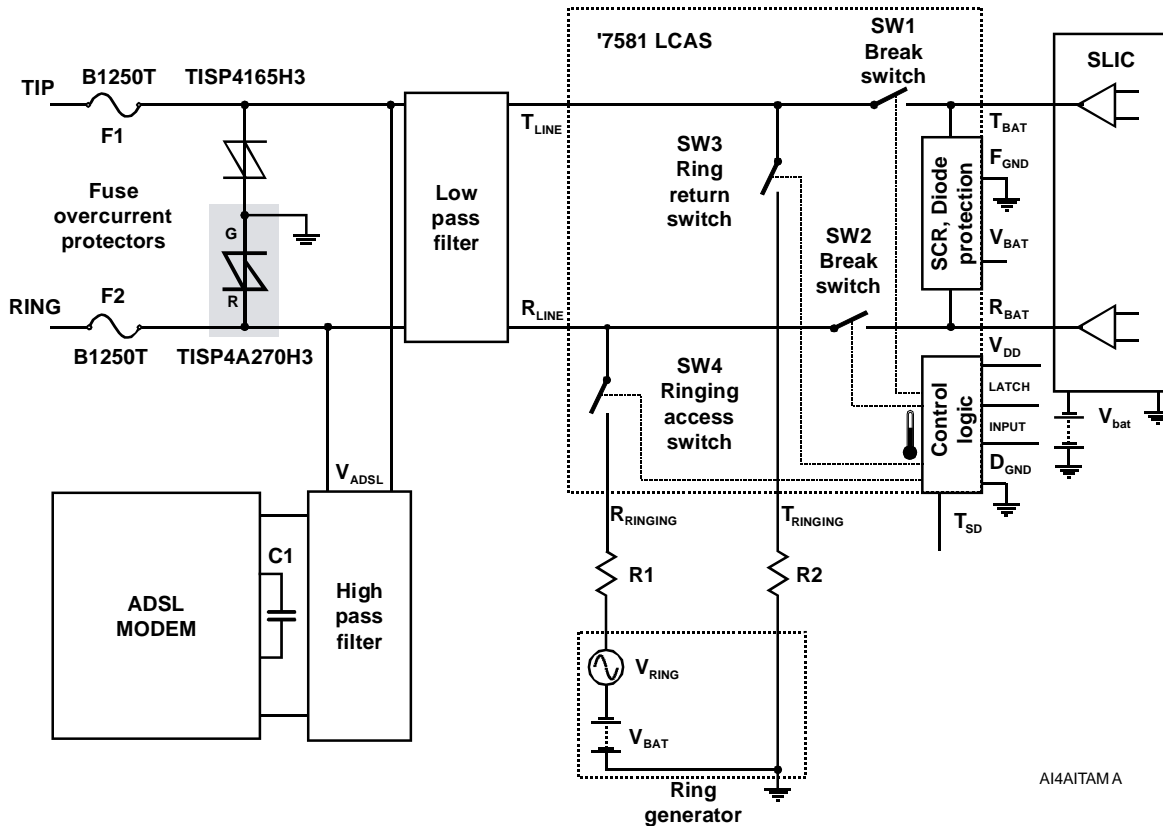

Figure 9. ADSL IVD using Common Protection

APRIL 2002 – REVISED JULY 2019

Specifications are subject to change without notice.

Users should verify actual device performance in their specific applications.

The products described herein and this document are subject to specific legal disclaimers as set forth on the last page of this document, and at [www.bourns.com/docs/legal/disclaimer.pdf](http://www.bourns.com/docs/legal/disclaimer.pdf).

## MECHANICAL DATA

### Recommended Printing Wiring Land Pattern Dimensions

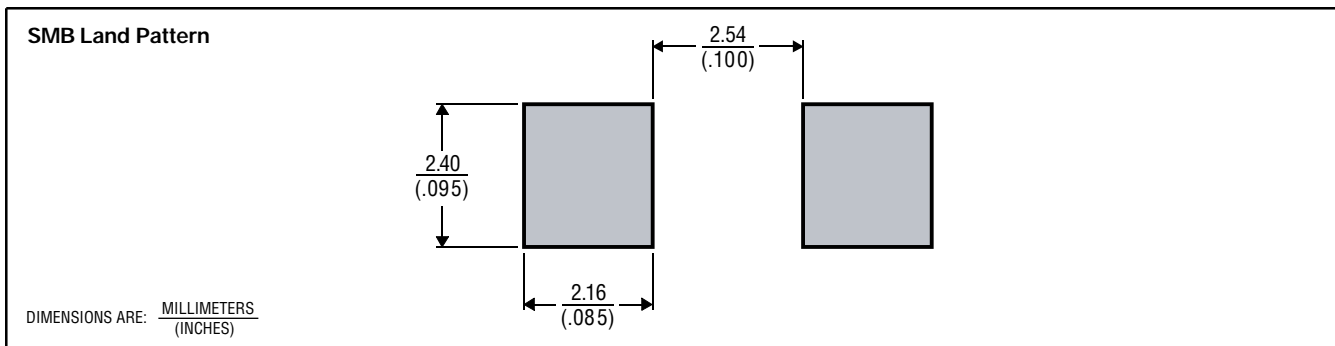

MDXXBID

### Device Symbolization Code

Devices will be coded as below. Terminal 1 is indicated by an adjacent bar marked on the package body.

Device	Symbolization Code
TISP4A270H3BJ	4A270H

### Carrier Information

For production quantities, the carrier will be embossed tape reel pack. Evaluation quantities may be shipped in bulk pack or embossed tape.

Package	Carrier	Standard Quantity
SMB	Embossed Tape Reel Pack	3000

**Asia-Pacific:** Tel: +886-2 2562-4117 • Email: asiacus@bourns.com

**EMEA:** Tel: +36 88 885 877 • Email: eurocus@bourns.com

**The Americas:** Tel: +1-951 781-5500 • Email: americus@bourns.com

[www.bourns.com](http://www.bourns.com)

"TISP" is a trademark of Bourns, Ltd., a Bourns Company, and is Registered in the U.S. Patent and Trademark Office. "Bourns" is a registered trademark of Bourns, Inc. in the U.S. and other countries.

APRIL 2002 – REVISED JULY 2019

Specifications are subject to change without notice.

Users should verify actual device performance in their specific applications.

The products described herein and this document are subject to specific legal disclaimers as set forth on the last page of this document, and at [www.bourns.com/docs/legal/disclaimer.pdf](http://www.bourns.com/docs/legal/disclaimer.pdf).

This legal disclaimer applies to purchasers and users of Bourns® products manufactured by or on behalf of Bourns, Inc. and its affiliates (collectively, “Bourns”).

Unless otherwise expressly indicated in writing, Bourns® products and data sheets relating thereto are subject to change without notice. Users should check for and obtain the latest relevant information and verify that such information is current and complete before placing orders for Bourns® products.

The characteristics and parameters of a Bourns® product set forth in its data sheet are based on laboratory conditions, and statements regarding the suitability of products for certain types of applications are based on Bourns’ knowledge of typical requirements in generic applications. The characteristics and parameters of a Bourns® product in a user application may vary from the data sheet characteristics and parameters due to (i) the combination of the Bourns® product with other components in the user’s application, or (ii) the environment of the user application itself. The characteristics and parameters of a Bourns® product also can and do vary in different applications and actual performance may vary over time. Users should always verify the actual performance of the Bourns® product in their specific devices and applications, and make their own independent judgments regarding the amount of additional test margin to design into their device or application to compensate for differences between laboratory and real world conditions.

Unless Bourns has explicitly designated an individual Bourns® product as meeting the requirements of a particular industry standard (e.g., ISO/TS 16949) or a particular qualification (e.g., UL listed or recognized), Bourns is not responsible for any failure of an individual Bourns® product to meet the requirements of such industry standard or particular qualification. Users of Bourns® products are responsible for ensuring compliance with safety-related requirements and standards applicable to their devices or applications.

Bourns® products are not recommended, authorized or intended for use in nuclear, lifesaving, life-critical or life-sustaining applications, nor in any other applications where failure or malfunction may result in personal injury, death, or severe property or environmental damage. Unless expressly and specifically approved in writing by two authorized Bourns representatives on a case-by-case basis, use of any Bourns® products in such unauthorized applications might not be safe and thus is at the user’s sole risk. Life-critical applications include devices identified by the U.S. Food and Drug Administration as Class III devices and generally equivalent classifications outside of the United States.

Bourns expressly identifies those Bourns® standard products that are suitable for use in automotive applications on such products’ data sheets in the section entitled “Applications.” Unless expressly and specifically approved in writing by two authorized Bourns representatives on a case-by-case basis, use of any other Bourns® standard products in an automotive application might not be safe and thus is not recommended, authorized or intended and is at the user’s sole risk. If Bourns expressly identifies a sub-category of automotive application in the data sheet for its standard products (such as infotainment or lighting), such identification means that Bourns has reviewed its standard product and has determined that if such Bourns® standard product is considered for potential use in automotive applications, it should only be used in such sub-category of automotive applications. Any reference to Bourns® standard product in the data sheet as compliant with the AEC-Q standard or “automotive grade” does not by itself mean that Bourns has approved such product for use in an automotive application.

Bourns® standard products are not tested to comply with United States Federal Aviation Administration standards generally or any other generally equivalent governmental organization standard applicable to products designed or manufactured for use in aircraft or space applications. Bourns expressly identifies Bourns® standard products that are suitable for use in aircraft or space applications on such products’ data sheets in the section entitled “Applications.” Unless expressly and specifically approved in writing by two authorized Bourns representatives on a case-by-case basis, use of any other Bourns® standard product in an aircraft or space application might not be safe and thus is not recommended, authorized or intended and is at the user’s sole risk.

The use and level of testing applicable to Bourns® custom products shall be negotiated on a case-by-case basis by Bourns and the user for which such Bourns® custom products are specially designed. Absent a written agreement between Bourns and the user regarding the use and level of such testing, the above provisions applicable to Bourns® standard products shall also apply to such Bourns® custom products.

Users shall not sell, transfer, export or re-export any Bourns® products or technology for use in activities which involve the design, development, production, use or stockpiling of nuclear, chemical or biological weapons or missiles, nor shall they use Bourns® products or technology in any facility which engages in activities relating to such devices. The foregoing restrictions apply to all uses and applications that violate national or international prohibitions, including embargos or international regulations. Further, Bourns® products and Bourns technology and technical data may not under any circumstance be exported or re-exported to countries subject to international sanctions or embargoes. Bourns® products may not, without prior authorization from Bourns and/or the U.S. Government, be resold, transferred, or re-exported to any party not eligible to receive U.S. commodities, software, and technical data.

To the maximum extent permitted by applicable law, Bourns disclaims (i) any and all liability for special, punitive, consequential, incidental or indirect damages or lost revenues or lost profits, and (ii) any and all implied warranties, including implied warranties of fitness for particular purpose, non-infringement and merchantability.

*For your convenience, copies of this Legal Disclaimer Notice with German, Spanish, Japanese, Traditional Chinese and Simplified Chinese bilingual versions are available at:*

*Web Page:* <http://www.bourns.com/legal/disclaimers-terms-and-policies>

*PDF:* <http://www.bourns.com/docs/Legal/disclaimer.pdf>

## Looking for pricing, stock, or lifecycle information?

Click below to explore more details on WIN SOURCE:

 [View PCSA1-S5-S12-S on WIN SOURCE](#)

 [CUI Inc. Information](#)

## Optimize Your Supply Chain with WIN SOURCE Solutions

-  Global Sourcing Solution
-  Obsolete Management
-  Cost Control Management
-  Shortage Management
-  Alternative Solution
-  Excess Inventory Management