



**THE DATASHEET OF  
TLP3553A(F**



# SE050

## Plug & Trust Secure Element

Rev. 3.8 — 18 October 2023

504938

Product data sheet



## 1 Introduction

---

The SE050 is a ready-to-use IoT secure element solution. It provides a root of trust at the IC level and it gives an IoT system state-of-the-art, edge-to-cloud security capability right out of the box.

SE050 allows for securely storing and provisioning credentials and performing cryptographic operations for security critical communication and control functions. SE050 is versatile in IoT security use cases such as secure connection to public/private clouds, device-to-device authentication or protection of sensor data.

SE050 has an independent Common Criteria EAL 6+ security certification up to OS level and supports both RSA & ECC asymmetric cryptographic algorithms with high key length and future proof ECC curves. The latest security measures protect the IC even against sophisticated non-invasive and invasive attack scenarios.

The SE050 is a turnkey solution that comes with Java Card operating system and an applet optimized for IoT security use cases pre-installed. This is complemented by a comprehensive product support package, enabling fast time to market & easy design-in with Plug & Trust middleware for host applications, easy to use development kits, reference designs, and extensive documentation for product evaluation.

The SE050 is a product platform that comes in several pin-to-pin compatible product variants, see [\[4\]](#).

Additional information on the integration can be found in several application notes on the [NXP website](#). See [\[3\]](#).

For additional information on guidelines for the usability of SE050 and the security recommendations for using the module, see [\[5\]](#)

To implement inclusive language, the terms "master/slave" has been replaced by "controller/target", following the recommendation of MIPI.

### 1.1 SE050 use cases

- Secure connection to public/private clouds, edge computing platforms, infrastructure
- Device-to-device authentication
- Secure data protection
- Secure commissioning support
- Secure CL/MIFARE/Wi-Fi interactions
- Device ID for blockchain
- Secure key storage
- Secure provisioning of credentials
- Ecosystem protection
- Qi 1.3 wireless charging authentication
- Matter Ready



### 1.2 SE050 target applications

- Smart Industry
- Smart Home
- Smart Cities
- Smart Supply Chains

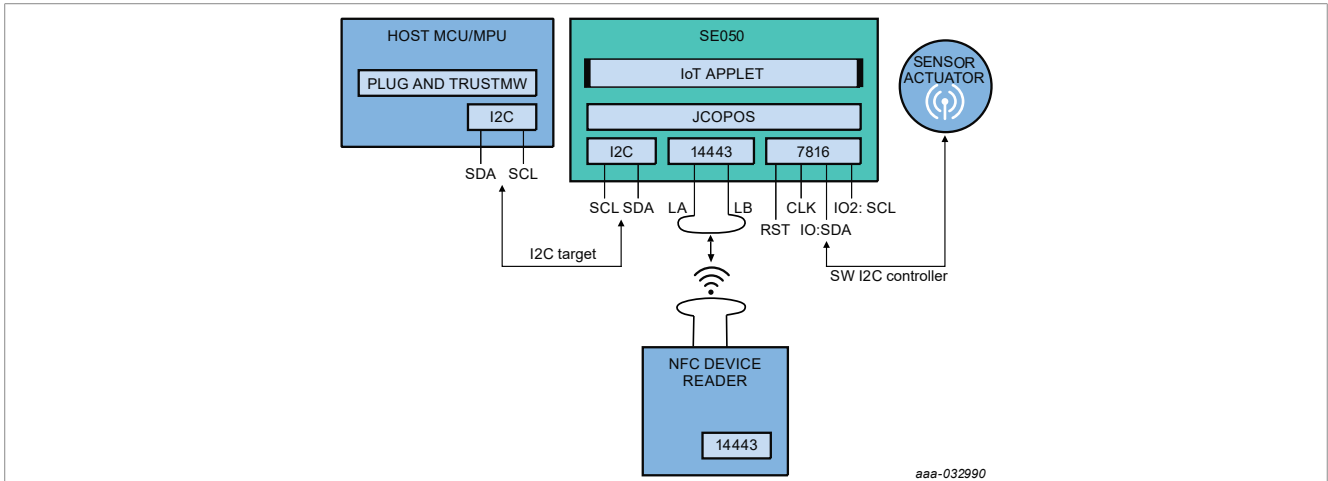

Figure 1. SE050 solution block diagram

**Note:** SE050 is designed to be used as a part of an IoT system. It works as an auxiliary security device attached to a host controller. The host controller communicates with SE050 through an I<sup>2</sup>C interface (with the host controller being the I<sup>2</sup>C controller and the SE050 being the I<sup>2</sup>C target). Besides the mandatory connection to the host controller, the SE050 device can optionally be connected to a sensor node or similar element through a separate I<sup>2</sup>C interface. In this case, the SE050 device is the I<sup>2</sup>C controller and the sensor node the I<sup>2</sup>C target. Lastly, SE050 has a connection for a native contactless antenna, providing a wireless interface to an external device like a smartphone.

### 1.3 SE050 naming convention

The following table explains the naming conventions of the commercial product name of the SE050 platform. Every SE050 product gets assigned a commercial name, which includes application specific data.

The SE050 commercial names have the following format.

**SE05yagddd/Zrfff**

All letters are explained in [Table 1](#).

Table 1. SE050 commercial name format

| Variable | Meaning       | Values                     | Description  |
|----------|---------------|----------------------------|--|
| y        | JCOP version  | 0                          |  |
| a        | Applet Config | A<br>B<br>C<br>D<br>E<br>F | Configuration options with different key provisioning options, see <a href="#">[4]</a> |

Table 1. SE050 commercial name format...continued

| Variable | Meaning           | Values              | Description  |
|----------|-------------------|---------------------|--|
| g        | Temperature range | 1<br>2              | Operational ambient temperature<br>1 = -25 °C - 85 °C ,<br>2 = -40 °C - 105 °C |
| ddd      | Delivery Type     | HQ1                 | HX2QFN20   |
| Zrfff    |                   | Letters and numbers | NXP internal code to identify individual configurations                        |

## 2 Features and benefits

### 2.1 Key benefits

- Plug & Trust for fast and easy design with complete product support package
- Easy integration with different MCU & MPU platforms and OS` (Linux, RTOS, Windows, Android, etc.)
- Turnkey solution ideal for system-level security without the need to write security code
- Secure credential injection for root of trust at IC level
- Secure, zero-touch connectivity to public & private clouds
- Real end-to-end security, from sensor to cloud
- Ready-to-use example code for each of the key use cases

### 2.2 Key features

The SE050 is based on NXP's Integral Security Architecture 3.0™ providing a secure and efficient protection against various security threats. The efficiency of the security measures is proven by a Common Criteria EAL6+ certification.

The SE050 operates fully autonomously based on an integrated Javacard operating system and applet. Direct memory access is possible by the fixed functionalities of the applet only. With that, the content from the memory is fully isolated from the host system.

- Built on NXP Integral Security Architecture 3.0™
- CC EAL 6+ certified HW and OS as environment to run NXP IoT applications, supporting fully encrypted communications and secured lifecycle management
- FIPS 140-2 certified platform with Security Level 3 for OS and Applet, and Security Level 4 related to Physical Security of the HW
  - Disclaimer: FIPS certification require a specific product type. For more information, refer to [\[4\]](#).
- Effective protection against advanced attacks, including Power Analysis and Fault Attacks of various kinds
- Multiple logical and physical protection layers, including metal shielding, end-to-end encryption, memory encryption, tamper detection
- Support for RSA and ECC asymmetric cryptography algorithms, future proof curves and high key length, e.g. Brainpool, Edwards and Montgomery curves
- Support for AES and DES symmetric cryptographic algorithms for encryption and decryption
- Support for AES Modes: CBC, EBC, CTR
- HMAC, CMAC, SHA-1, SHA-224/256/384/512 operations
- Various options for key derivation functions, including HKDF, MIFARE KDF, PRF (TLS-PSK)
- Extended temperature range for industrial applications (-40 °C to 105 °C)
- Small footprint HX2QFN20 package (3x3 mm)

- Standard physical interface I<sup>2</sup>C target (High-speed mode, 3.4 Mbit/s), I<sup>2</sup>C controller (Fast mode, 400 kbit/s). Both can be active at the same time
- Dedicated CL wireless interface for IoT use cases simplifying configuration set-up, maintenance in the field and late stage configuration
- Secured user flash memory up to 50 kB for secure data or key storage
- Support for SCP03 protocol (bus encryption and encrypted credential injection) to securely bind the host with the secure element
- TRNG compliant to NIST SP800-90B
- DRBG compliant to NIST SP800-90A
- Support for applet level secure messaging channels to allow end-to-end encrypted communication in multi-tenant ecosystems
- In 2022 NXP launched a new generation of product variants, the SE050E platform. The SE050E platform supports the following new features.
  - AES Modes: CCM and GCM
  - GMAC
  - EC Curves for ECDH: Curve448
- Matter Ready: SE050 provides the necessary cryptographic functions to support the upcoming Matter standard for connecting smart home devices.

**Note:** The available features in each product vary according to the chosen variant. More details are available on [\[4\]](#).

### 2.3 Features in detail

Table 2. Feature Overview

| Categories    | Subcategory                          | Value  |
|---------------|--------------------------------------|--|
| Standards     | Security certification               | CC EAL6+ (HW+JCOP), FIPS 140-2 L3                      |
|               | JavaCard version                     | 3.0.5  |
|               | GlobalPlatform specification version | GP 2.3.1   |
| Cryptography  | ECC                                  | ECDSA, ECDH, ECDHE, EdDSA                              |
|               | MAC                                  | HMAC, secure HMAC, CMAC, GMAC <sup>[1]</sup>           |
|               | Hash                                 | SHA-1, SHA-224, SHA-256, SHA-384, SHA-512              |
|               | Key derivation                       | HKDF, PBKDF2, PRF (TLS-PSK), MIFARE-AES-KDF            |
|               | AES                                  | AES (128, 192, 256)                                    |
|               | AES Modes                            | CBC, ECB, CTR, CCM <sup>[1]</sup> , GCM <sup>[1]</sup> |
|               | 3DES                                 | 2K, 3K   |
|               | RSA                                  | RSA cipher for de-/encryption (up to 4096 bit)         |
| Crypto curves | ECC                                  | ECC NIST (192 to 521 bit)                              |
|               |                                      | Brainpool (160 to 512 bit)                             |
|               |                                      | Twisted Edwards Ed25519 / Montgomery Curve25519        |
|               |                                      | Koblitz (192 bit to 256 bit)                           |
|               |                                      | Montgomery (Curve448) [Goldilocks] <sup>[1]</sup>      |

Table 2. Feature Overview...continued

| Categories         | Subcategory                          | Value  |
|--------------------|--------------------------------------|--|
| User memory        |                                      | 50 kB  |
| TRNG               |                                      | NIST SP800-90B, AIS31                                  |
| DRBG               |                                      | NIST SP800-90A, AIS20                                  |
| Memory reliability |                                      | up to 100 Mio write cycles / 25 years                  |
| Interfaces         | I <sup>2</sup> C Target              | High-speed mode (3.4 Mbit/s)                           |
|                    | I <sup>2</sup> C Controller          | Fast Mode (400 kbit/s)                                 |
|                    | Contactless                          | ISO14443-A PICC  |
| Power saving modes | Power-Down (with state retention)    | < 500 $\mu$ A  |
|                    | Deep Power-Down (no state retention) | <5 $\mu$ A   |
| Temperature        | Standard                             | -25 °C - 85 °C, see <a href="#">Naming Conventions</a> |
|                    | Extended                             | -40 - 105 °C, see <a href="#">Naming Conventions</a>   |
| Packaging          | Plastic QFN                          | 3 x 3 mm (HX2QFN20)                                    |

[1] New feature of the new generation of SE050 product family.

### 3 Functional description

#### 3.1 Functional diagram

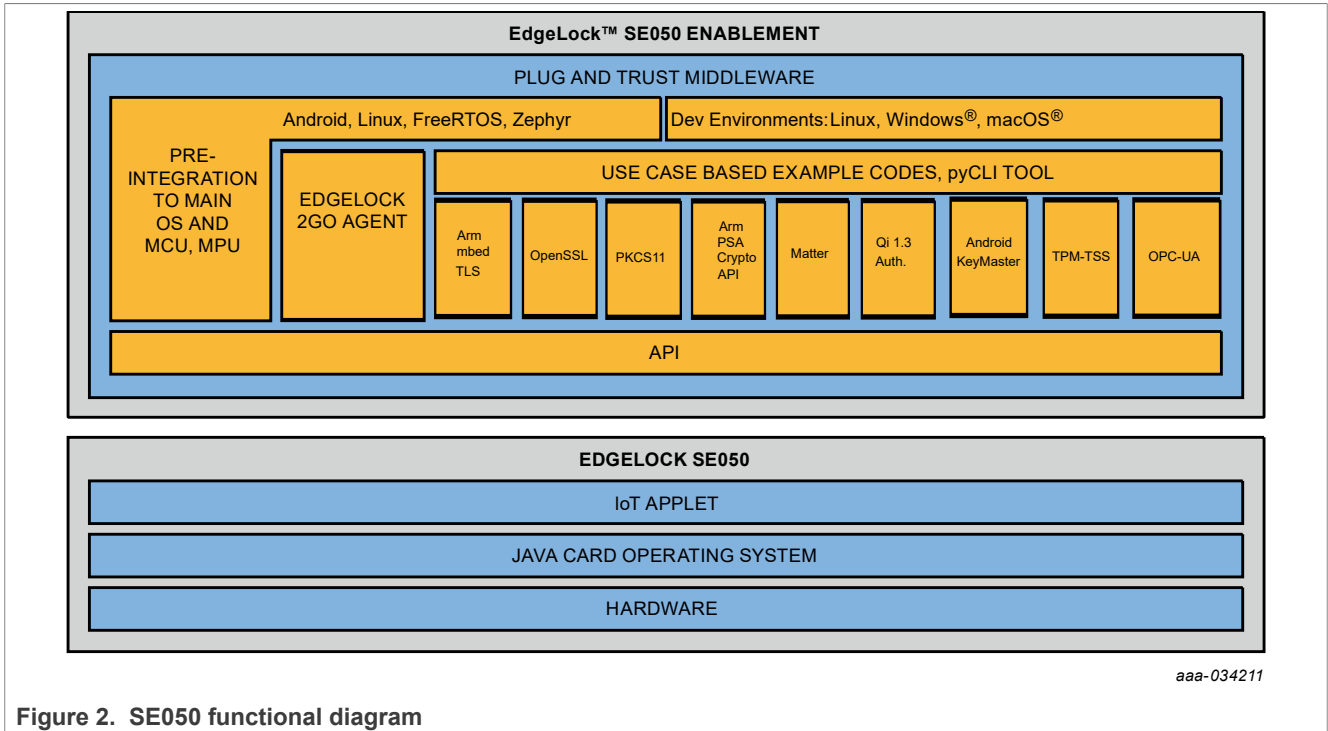

Figure 2. SE050 functional diagram

The SE050 uses I<sup>2</sup>C as communication interface. [Section 4](#) gives more details. The SE050 commands are wrapped using the Smartcard T=1 over I<sup>2</sup>C (T=1o I2C) protocol. The detailed documentation of the SE050 commands (see [\[3\]](#)) and T=1 over I2C protocol encapsulation is available on [\[1\]](#).

In order to simplify the product usage a host library which abstracts for SE050 commands and T=1 over I<sup>2</sup>C protocol encapsulation is provided. The host library supporting various platforms is available for download including complete source code on the SE050 website.

SE050 IoT applet features a generic file system capable of securely storing secure objects and associated privilege management. All objects can either be stored in persistent memory or in RAM with the capability to securely export and import them to be stored in an externally provided storage. All secure objects feature basic file operations such as write, read, delete and update.

##### 3.1.1 Random number generator

The SE050 IoT Applet provides random numbers using an AIS20 compliant pseudo random number generator (PRNG) with class DRG.4 generator initialized by a TRNG compliant to AIS31 class PTG.2. The PRNG is implemented according to NIST SP800-90Arev1.

DRG.3 functionality is a subset of DRG.4, therefore the TOE is also compliant to DRG.3.

### 3.1.2 Supported secure object types

A secure object is an entry in the file system of SE050. Each secure object has certain features and capabilities. The following secure object types are available (for more details on the objects refer to [\[3\]](#)):

- Symmetric Key (AES, 3DES)
- ECC Key
- RSA Key
- HMAC Key
- Binary File
- User ID
- Counter
- Hash-Extend register

### 3.1.3 Access control

Each secure object can be linked to object specific access control policies. An access control policy associates a user identified by an authentication with a set of privileges such as read, write, ...

To scale the functionality into a broad range of ecosystems, a set of different authentication options is provided:

- User-ID based authentication
- Symmetric key based authentication with secure messaging
- Asymmetric key based authentication with secure messaging

At creation of a secure object, an optional set of policies is associated with that secure object. Each policy assigns a set of allowed operations on that object to an authentication object.

### 3.1.4 Sessions and multi-threading

The SE050 IoT applet is prepared for ecosystems where multi-threading and multi-tenant use cases are needed on APDU level. To enable that, the applet supports 2 simultaneous sessions that can span full secure messaging sessions, self-authenticated APDUs for tenants not requiring long-lasting sessions and on top one default session for single tenant use cases .

### 3.1.5 Attestation and trust provisioning

SE050 applet comes with a set of trust provisioned root credentials allowing the owner of the device to securely attest all generated secure keys. Next to that, a customer has the possibility to define own attestation keys.

Attestation certificates signed by an attestation CA are included in certain SE050 configurations as documented in [\[4\]](#).

### 3.1.6 Application support

For specific ecosystems, SE050 IoT applet has built-in crypto features to simplify the deployment of specific use cases such as

- MIFARE SAM functionality
- Wi-Fi password protection
- ECC-Key and RSA-Key based cloud connectivity
- Secure Sensor readout using I<sup>2</sup>C controller
- Remote attestation and trust provisioning
- Platform Configuration Registers

### 3.2 Credential Storage & Memory

Within SE050, all credentials and secure objects are stored inside a dynamic file structure. At creation, a user has to associate a file identifier with the object created. This identifier is then used in subsequent operations to access the object. The number of objects that can be allocated is only limited by the available memory in the system. After usage, objects can be deleted and the associated memory is freed up again.

There is also the possibility to create transient objects. Transient objects have an object descriptor stored in non-volatile memory, but the object content is stored in RAM. Together with the import/export functionality of SE050, transient objects can be used securely store secret keys in a remote memory system.

### 3.3 Preprovisioned "Ease of Use" configurations

Some generic SE050 variants are offered pre-configured for ease of use and can be used during development phase and in the field. With this customers have all keys pre-injected in SE050 that are required for the main use cases as e.g. cloud onboarding. For more information, see: [\[4\]](#)

### 3.4 Startup behavior

If a supply voltage is applied to pins  $V_{in}$ ,  $V_{CC}$  within the specified supply voltage operating range or an RF field according to ISO/IEC 14443 is applied to antenna pins LA, LB the IC boots up.

During boot the IC checks for active interface according list below (in the order of the list):

- ISO7816: If interface available for this product type, check CLK to be toggling, then wait for RST to be high
- ISO14443: If interface available for this product type, check of RF field on LA, LB antenna pins
- I<sup>2</sup>C: If interface available for this product type, check if both I<sup>2</sup>C\_SDA, I<sup>2</sup>C\_SCL pins are at high level (internal weak pull-up active)
- The chosen interface is the only interface the SE050 will receive commands for processing. To select a different interface the IC needs to be reset.

## 4 Communication interfaces

### 4.1 I<sup>2</sup>C Interfaces

The I<sup>2</sup>C interface vary according the specific SE050 variant see [Section 4.1.1](#).

The SE050 has one I<sup>2</sup>C interface supporting target and one I<sup>2</sup>C interface supporting controller mode.

The I<sup>2</sup>C target interface is the main communication interface of the device and is used by the host controller to send arbitrary APDUs to the device. It supports clock frequencies up to 3.4 MHz when operated in High-Speed Mode (HS). The I<sup>2</sup>C interface is using the Smartcard T=1 over I<sup>2</sup>C protocol.

The default target address of the SE050 is configured to 0x48.

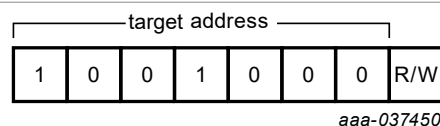

Figure 3. target address

The I<sup>2</sup>C controller interface is supposed to be used with target devices that need to be securely written and read. This interface features a maximum SCL clock rate of 400 kHz.

I<sup>2</sup>C controller can only be used when the I<sup>2</sup>C target interface is active.

### 4.1.1 Supported I<sup>2</sup>C frequencies

The SE050 I<sup>2</sup>C target interface supports the I<sup>2</sup>C high-speed mode with a maximum SCL clock of up to 3.4 MHz when clock stretching is enabled. In case clock stretching is disabled the maximum supported SCL clock frequency is 1 MHz. This is the default setting for the SE050 new generation products, SE050E.

In the following SE050 configurations, A,B,C,D,F, the Clock stretching is enabled by default. Clock stretching will occur for frequencies higher than 600 kHz. In case clock stretching is not supported by the I<sup>2</sup>C controller a dedicated configuration with disabled clock stretching has to be used to ensure the above mentioned maximum clock frequency.

The SE050 I<sup>2</sup>C controller interface supports maximum 400 kHz SCL clock frequency.

For more details on the features of each configuration, refer to [\[4\]](#).

## 4.2 ISO7816 and ISO14443 Interface

The SE050 supports in addition to the I<sup>2</sup>C interface ISO7816<sup>1</sup> and ISO14443-A Smartcard interfaces. For the ISO7816 interface SmartCard protocols T=0 and T=1 are supported. For the ISO14443 interface protocol T=CL is used. The supported resonance input capacitance is 56 pF. In addition one additional GPIO pad IO2 is supported.

The RST\_N pin can only be used as external reset source if the ISO7816 interface is enabled. If only the I<sup>2</sup>C interface is enabled, the RST\_N pad has no effect. If the SE050 is kept in reset state the current consumption is as defined for idle, see [Table 12](#).

## 5 Power-saving modes

The device provides two power-saving operation modes. The Power-down mode (with state retention) and the Deep Power-down mode (no state retention). These modes are activated via pad ENA (Deep Power-down mode) or by the SW (Power-down mode).

### 5.1 Power-down mode

The Power-down mode has the following properties:

- All internal clocks are frozen
- CPU enters power-saving mode with program execution being stopped
- CPU registers keep their contents
- RAM keeps its contents

The SE050 enters into Power-down mode by receiving "End of APDU session request" via the T=1 over I<sup>2</sup>C protocol. In Power-down mode, all internal clocks are frozen. The IOs hold the logical states they had at the time Power-down mode was activated.

To exit from the Power-down mode an external interrupt edge must be triggered by a falling edge on I<sup>2</sup>C\_SDA<sup>2</sup>.

### 5.2 Deep Power-down mode

The SE050 provides a special power-saving mode offering maximum power saving. This mode is activated by pulling enable PIN (ENA) to a logic zero level.

<sup>1</sup> ISO7816 is not enabled in generic SE050 configurations (see [\[4\]](#), AN12436) but available on customer request.

<sup>2</sup> In case ISO7816 is enabled a reset signal on RST\_N exits the Power-down mode. After wake-up from Power-down mode via RST\_N the device is in idle mode (see [Table 12](#))

While in Deep Power-down mode the internal power and  $V_{OUT}$  is switched off completely and only the  $I^2C$  pads stay supplied.

To leave the Deep Power-down mode pad ENA has to be pulled up to a logic „1" level.

For usage of Deep Power-down mode the SE050 must be supplied via pin  $V_{in}$  and pin  $V_{CC}$  needs to be supplied by pin  $V_{out}$ .

## 6 Ordering information

### 6.1 Ordering options

Table 3. SE050 Ordering information

| 12NC           | Type number      | SE050 Variant | Orderable part number |
|----------------|------------------|---------------|-----------------------|
| 9354 343 82472 | SE050E2HQ1/Z01Z3 | SE050E2       | SE050E2HQ1/Z01Z3Z     |
| 9354 284 44472 | SE050F2HQ1/Z018H | SE050F2       | SE050F2HQ1/Z018HZ     |
| 9353 867 22472 | SE050A1HQ1/Z01SG | SE050A1       | SE050A1HQ1/Z01SGZ     |
| 9353 869 84472 | SE050A2HQ1/Z01SH | SE050A2       | SE050A2HQ1/Z01SHZ     |
| 9354 015 87472 | SE050D2HQ1/Z01PA | SE050D2       | SE050D2HQ1/Z01PAZ     |
| 9353 869 85472 | SE050B1HQ1/Z01SE | SE050B1       | SE050B1HQ1/Z01SEZ     |
| 9353 869 86472 | SE050B2HQ1/Z01SF | SE050B2       | SE050B2HQ1/Z01SFZ     |
| 9353 869 87472 | SE050C1HQ1/Z01SC | SE050C1       | SE050C1HQ1/Z01SCZ     |
| 9353 869 88472 | SE050C2HQ1/Z01SD | SE050C2       | SE050C2HQ1/Z01SDZ     |

Table 4. SE050 Ordering information for development kit

| 12NC           | Type number   | Description  |
|----------------|---------------|--|
| 9354 332 66598 | OM-SE050ARD-E | SE050 Arduino-compatible development kit, SE050E configuration |
| 9354 357 63598 | OM-SE050ARD-F | SE050 Arduino compatible development kit, SE050F configuration |
| 9353 832 82598 | OM-SE050ARD   | SE050 Arduino-compatible development kit, SE050C configuration |

### 6.2 Ordering SE050 samples

Samples can be ordered from NXP Semiconductors via [nxp.com](http://nxp.com) using the "Buy Direct" button on the product information page for SE050. Note that NXP Semiconductors can provide up to five pieces free of charge. Larger quantities have to be ordered commercially.

### 6.3 Configuration

Detailed information about the configurations and enabled features for each available variant of the SE050 are available in a separate NXP Application Note, see [\[4\]](#)

## 7 Pinning information

### 7.1 Pinning

#### 7.1.1 Pinning HX2QFN20

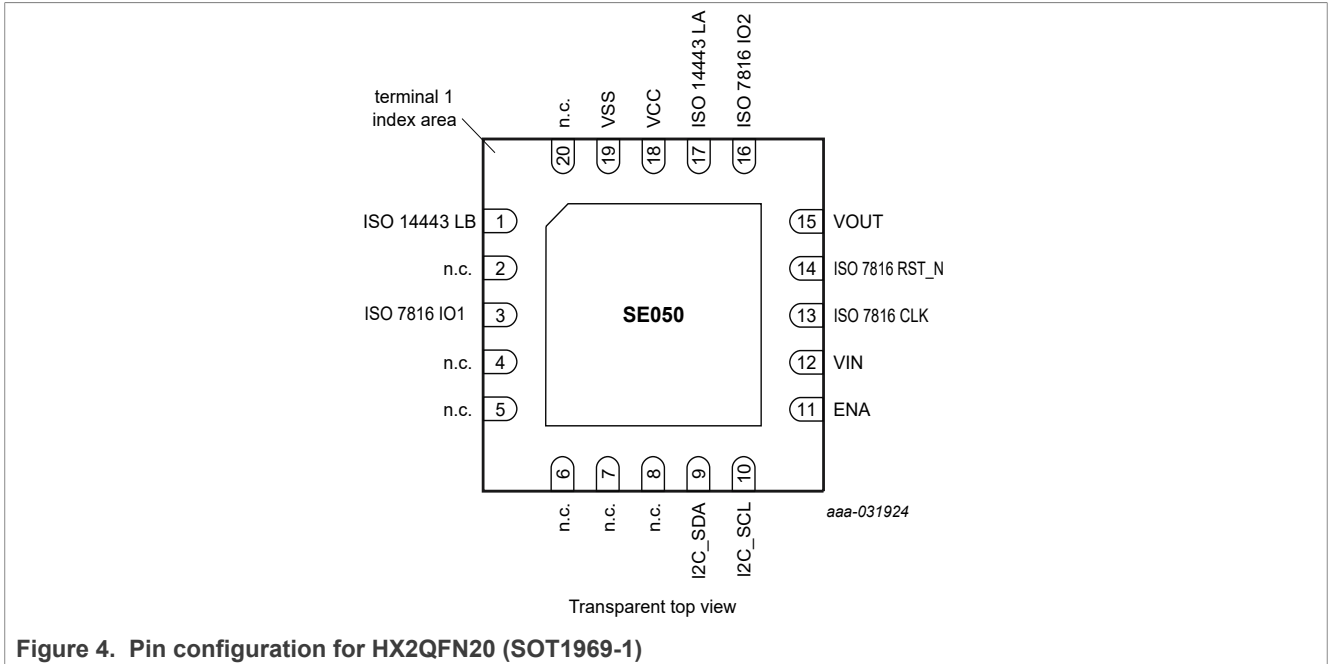

Figure 4. Pin configuration for HX2QFN20 (SOT1969-1)

**Note:** Terminal 1 index area is marked on the bottom with a notch on the center pad and on the top with a printed dot.

Table 5. Pin description HX2QFN20

| Symbol               | Pin | Description   |
|----------------------|-----|---|
| ISO 14443 LB         | 1   | ISO14443 Antenna Connection, if not used connect to $V_{SS}$  |
| n.c.                 | 2   | not connected   |
| ISO 7816 IO1         | 3   | ISO 7816 IO or I <sup>2</sup> C controller SDA, if not used n.c (recommended) or connect to $V_{CC}$                                    |
| n.c.                 | 4   | not connected   |
| n.c.                 | 5   | not connected   |
| n.c.                 | 6   | not connected   |
| n.c.                 | 7   | not connected   |
| n.c.                 | 8   | not connected   |
| I <sup>2</sup> C_SDA | 9   | I <sup>2</sup> C target data, if not used n.c.  |
| I <sup>2</sup> C_SCL | 10  | I <sup>2</sup> C target clock, if not used n.c.   |
| ENA                  | 11  | Deep Power-down mode enable, if not used then connect to $V_{CC}$   |
| $V_{IN}$             | 12  | power supply voltage input for I <sup>2</sup> C pads and ISO 7816/14443 interface and logic supply in case Deep Power-down mode is used |
| ISO 7816 CLK         | 13  | ISO 7816 clock input, if not used then n.c (recommended) or connect to $V_{CC}$   |

Table 5. Pin description HX2QFN20...continued

| Symbol           | Pin | Description   |
|------------------|-----|---|
| ISO 7816 RST_N   | 14  | ISO 7816 reset input low active, if not used then connect to V <sub>CC</sub> or V <sub>SS</sub>   |
| V <sub>out</sub> | 15  | supply voltage output to be connected with pad V <sub>CC</sub> on PCB level, if Deep Power-down mode is used. n.c. if not used.                             |
| ISO 7816 IO2     | 16  | ISO7816 IO2 pad or I <sup>2</sup> C controller SCL. I if not used n.c (recommended) or connect to V <sub>out</sub> .  |
| ISO 14443 LA     | 17  | ISO14443 antenna connection, if not used then connect to V <sub>SS</sub>  |
| V <sub>CC</sub>  | 18  | logic and ISO7816/ISO14443 interface power supply voltage input, to be connected with pad V <sub>out</sub> on PCB level, if Deep Power-down mode to be used |
| V <sub>SS</sub>  | 19  | ground  |
| n.c.             | 20  | not connected   |

The center pad of the IC is not connected, although it is recommended to connect it to ground for thermal reasons.

Reference voltage for ISO 7816 IO1, CLK, RST is V<sub>CC</sub>; for I<sup>2</sup>C, SDL, and SCL reference voltage is V<sub>in</sub> and for IO2 it is V<sub>out</sub>.

## 8 Package

SE050 is offered in HX2QFN20 package. The dimensions are 3 mm x 3 mm x 0,32 mm with a 0,4 mm pitch.

Please refer to the package data sheet [2], SOT1969-1.

## 9 Marking

Table 6. Marking codes

| Type number | Marking code   |
|-------------|--|
| Sx050...    | Line A: S50<br>Line B: **** (**** = 4-digit Batch code)<br>Line C: nDyww<br>D: RHF-2006 indicator<br>n: Assembly Center<br>Y: Year<br>WW: Week |

## 10 Packing information

### 10.1 Reel packing

The SE050 product is available in tape on reel.

Table 7. Reel packing options

| Symbol   | Parameter       | Numbers of units per reel |
|----------|-----------------|---------------------------|
| HX2QFN20 | 7" tape on reel | 3000                      |

## 11 Electrical and timing characteristics

The electrical interface characteristics of static (DC) and dynamic (AC) parameters for pads and functions used for I<sup>2</sup>C are in accordance with the NXP I<sup>2</sup>C specification (see [1]).

## 12 Limiting values

**Table 8. Limiting values**

In accordance with the Absolute Maximum Rating System (IEC 60134). Voltages are referenced to V<sub>SS</sub> (ground = 0 V).

| Symbol                            | Parameter   | Conditions   | Min  | Max              | Unit |
|-----------------------------------|---|--|------|------------------|------|
| V <sub>in</sub> , V <sub>CC</sub> | supply voltage  |  | -0.3 | 6 <sup>[1]</sup> | V    |
| V <sub>in</sub>                   | input voltage   | any signal pad   | -0.3 | 6                | V    |
| I <sub>I</sub>                    | input current   | pad I <sup>2</sup> C_SDA, I <sup>2</sup> C_SCL   | -    | 10               | mA   |
| I <sub>o</sub>                    | output current  | pad I <sup>2</sup> C_SDA, I <sup>2</sup> C_SCL   | -    | 10               | mA   |
| I <sub>lu</sub>                   | latch-up current                                      | V <sub>I</sub> < 0 V or V <sub>I</sub> > V <sub>in</sub> , V <sub>CC</sub>   | -    | 100              | mA   |
| V <sub>esd_hbm</sub>              | electrostatic discharge voltage (Human Body Model)    | pads V <sub>CC</sub> , V <sub>SS</sub> , RST_N, I <sup>2</sup> C_SDA, I <sup>2</sup> C_SCL, IO1, IO2, CLK <sup>[2]</sup> | -    | ± 2              | kV   |
| V <sub>esd_cdm</sub>              | electrostatic discharge voltage (Charge Device Model) | pads V <sub>CC</sub> , V <sub>SS</sub> , RST_N, I <sup>2</sup> C_SDA, I <sup>2</sup> C_SCL, IO1, IO2, CLK <sup>[3]</sup> | -    | ± 500            | V    |
| P <sub>tot</sub>                  | Total power dissipation                               | <sup>[4]</sup>   | -    | 600              | mW   |
| T <sub>stg</sub>                  | Storage temperature                                   |  | -55  | 125              | °C   |

[1] Maximum supported supply voltage is 6 V. The SE050 is characterized for the specified operating supply voltage range of 1.62 V to 3.6 V. In case of supply voltages above 3.6 V, Deep Power-down mode current <5 μA is not guaranteed.

[2] MIL Standard 883-D method 3015; human body model; C = 100 pF, R = 1.5 kΩ; T<sub>amb</sub> = -40 °C to 105 °C.

[3] JEDEC22-C101, JEDEC Standard Field induced charge device model test method.

[4] Depending on appropriate thermal resistance of the package.

## 13 Recommended operating conditions

The SE050 is characterized by its specified operating supply voltage range of 1.62 V to 3.6 V.

**Table 9. Recommended operating conditions**

| Symbol                            | Parameter   | Conditions                      | Min  | Typ | Max   | Unit |
|-----------------------------------|---|---------------------------------|------|-----|---|------|
| V <sub>in</sub> , V <sub>CC</sub> | Supply voltage  | Nominal supply voltage          | 1.62 | 1.8 | 3.6 <sup>[1]</sup>                                    | V    |
| V <sub>in</sub>                   | DC input voltage on digital inputs and digital I/O pads | -                               | -0.3 | -   | V <sub>CC</sub> /V <sub>in</sub> <sup>[2]</sup> + 0.3 | V    |
| H                                 | Field strength  | Contactless interface operation | 1.5  | -   | 7.5   | A/m  |
| T <sub>amb</sub>                  | Operating ambient temperature <sup>[3]</sup>            |                                 | -40  | -   | 105   | °C   |

[1] Maximum supported supply voltage is 6 V. In case of supply voltages above 3.6 V, Deep Power-down mode current <5 μA is not guaranteed.

[2] IO1, CLK, RST has V<sub>CC</sub> as reference, SDA, SCL, IO2 and ENA has V<sub>IN</sub> as reference

[3] All product properties and values specified within this data sheet are only valid within the operating ambient temperature range.



Maximum supported supply voltage is 6 V. In case of supply voltages above 3.6 V, Deep Power-down mode current <math>< 5 \mu\text{A}</math> is not guaranteed.

Figure 5. Characteristic supply voltage operating range

## 14 Characteristics

### 14.1 DC characteristics

#### Measurement conventions

Testing measurements are performed at the contact pads of the device under test. All voltages are defined with respect to the ground contact pad  $V_{SS}$ . All currents flowing into the device are considered positive.

#### 14.1.1 General and General Purpose I/O interface

Table 10. Electrical DC characteristics of Input/Output: IO1/IO2. Conditions:  $V_{CC} = 1.62 \text{ V to } 3.6 \text{ V}$  (see ;  $V_{SS} = 0 \text{ V}$ ;  $T_{amb} = -40 \text{ }^\circ\text{C to } 105 \text{ }^\circ\text{C}$ , unless otherwise specified

In Table 10  $V_{CC}$  means for IO1 voltage on  $V_{CC}$  pin, for IO2 voltage on  $V_{IN}$  pin

Maximum supported supply voltage is 6 V. In case of supply voltages above 3.6 V, Deep Power-down mode current <math>< 5 \mu\text{A}</math> is not guaranteed.

| Symbol     | Parameter   | Conditions  | Min                 | Typ | Max                  | Unit          |
|------------|---|---|---------------------|-----|----------------------|---------------|
| $V_{IH}$   | HIGH level input voltage  |   | $0.7 \times V_{CC}$ | -   | $V_{CC} + 0.3$       | V             |
| $V_{IL}$   | LOW level input voltage   |   | -0.3                | -   | $0.25 \times V_{CC}$ | V             |
| $I_{IH}$   | HIGH level input current in "weak pull-up" input mode                               | $0.7 V_{CC} \leq V_{in} \leq V_{CC}$ Test conditions for the maximum absolute value: $I_{IH(max)}$ :<br>$V_{in} = 0.7 \times V_{CC}$ , $V_{CC} = V_{CC(max)}$   | -                   | -   | -20                  | $\mu\text{A}$ |
| $I_{IL}$   | LOW level input current   | $0 \text{ V} \leq V_{in} \leq 0.3 V_{CC}$ ;<br>Test conditions for the maximum absolute value: $I_{IL(max)}$ :<br>$V_{in} = 0 \text{ V}$ , $V_{CC} = V_{CC(max)}$   | -                   | -   | -50                  | $\mu\text{A}$ |
| $I_{TL}$   | HIGH-to-LOW transition input current (only "quasi-bidirectional" mode)              | $0.3 V_{CC} < V_{in} \leq V_{CC}$ ; Test conditions for the maximum absolute value: $V_{in} = 0.5 V_{CC}$ , $V_{CC} = V_{CC(max)}$  | [1]                 | -   | -250                 | $\mu\text{A}$ |
| $I_I$      | Input current in "weak pull-up" input mode  | $0 \text{ V} \leq V_I \leq V_{CC}$ ; Test conditions for the maximum absolute value: $I_{I(max)}$ :<br>$V_{in} = 0 \text{ V}$ , $V_{CC} = V_{CC(max)}$  | 0                   | -   | -50                  | $\mu\text{A}$ |
| $I_{ILIH}$ | Leakage input current at input voltage beyond $V_{CC}$ in "weak pull-up" input mode | $V_{CC} < V_{in} \leq V_{CC} + 0.3 \text{ V}$ ;<br>$-40 \text{ }^\circ\text{C} \leq T_{amb} \leq 105 \text{ }^\circ\text{C}$ ;<br>Test conditions: $V_{in} = V_{CC} + 0.3 \text{ V}$ ;<br>$V_{CC} = V_{CC(max)}$ , $T_{amb} = 105 \text{ }^\circ\text{C}$ | -                   | -   | 20                   | $\mu\text{A}$ |

**Table 10. Electrical DC characteristics of Input/Output: IO1/IO2. Conditions:  $V_{CC} = 1.62\text{ V}$  to  $3.6\text{ V}$  (see ;  $V_{SS} = 0\text{ V}$ ;  $T_{amb} = -40\text{ }^{\circ}\text{C}$  to  $105\text{ }^{\circ}\text{C}$ , unless otherwise specified...continued**

In [Table 10](#)  $V_{CC}$  means for IO1 voltage on  $V_{CC}$  pin, for IO2 voltage on  $V_{IN}$  pin

Maximum supported supply voltage is 6 V. In case of supply voltages above 3.6 V, Deep Power-down mode current  $<5\text{ }\mu\text{A}$  is not guaranteed.

| Symbol     | Parameter   | Conditions   | Min                 | Typ | Max                  | Unit          |
|------------|---|--|---------------------|-----|----------------------|---------------|
| $I_{ILIL}$ | Leakage input current at input voltage below $V_{SS}$ in "weak pull-up" input mode          | $-0.3\text{ V} \leq V_{in} < 0\text{ V}$ ;<br>$-40\text{ }^{\circ}\text{C} \leq T_{amb} \leq 30\text{ }^{\circ}\text{C}$<br>Test conditions: $V_{in} = -0.3\text{ V}$ ;<br>$V_{CC} = V_{CC(max)}$ , $T_{amb} = 30\text{ }^{\circ}\text{C}$               | -                   | -   | -50                  | $\mu\text{A}$ |
|            |   | $-0.3\text{ V} \leq V_{in} < 0\text{ V}$ ;<br>$30\text{ }^{\circ}\text{C} \leq T_{amb} \leq 105\text{ }^{\circ}\text{C}$<br>Test conditions: $V_{in} = -0.3\text{ V}$ ;<br>$V_{CC} = V_{CC(max)}$ , $T_{amb} = 105\text{ }^{\circ}\text{C}$              | -                   | -   | -1000                | $\mu\text{A}$ |
| $I_{LIHQ}$ | Leakage input current at input voltage beyond $V_{CC}$ (only in "quasi-bidirectional" mode) | $V_{CC} < V_{in} \leq V_{CC} + 0.3\text{ V}$ ;<br>$-40\text{ }^{\circ}\text{C} \leq T_{amb} \leq 105\text{ }^{\circ}\text{C}$<br>Test conditions: $V_{in} = V_{CC} + 0.3\text{ V}$ ;<br>$V_{CC} = V_{CC(max)}$ ; $T_{amb} = 105\text{ }^{\circ}\text{C}$ | -                   | -   | 100                  | $\mu\text{A}$ |
| $I_{LILQ}$ | Leakage input current at input voltage below $V_{SS}$ (only in "quasi-bidirectional" mode)  | $-0.3\text{ V} \leq V_{in} < 0\text{ V}$ ; $-40\text{ }^{\circ}\text{C} \leq T_{amb} \leq 30\text{ }^{\circ}\text{C}$<br>Test conditions: $V_{in} = -0.3\text{ V}$ ;<br>$V_{CC} = V_{CC(max)}$ , $T_{amb} = 30\text{ }^{\circ}\text{C}$                  | -                   | -   | -120                 | $\mu\text{A}$ |
|            |   | $-0.3\text{ V} \leq V_{in} < 0\text{ V}$ ; $30\text{ }^{\circ}\text{C} \leq T_{amb} \leq 105\text{ }^{\circ}\text{C}$ ;<br>Test conditions: $V_{in} = -0.3\text{ V}$ ; $V_{CC} = V_{CC(max)}$ , $T_{amb} = 105\text{ }^{\circ}\text{C}$                  | -                   | -   | -1000                | $\mu\text{A}$ |
| $V_{OH}$   | HIGH level output voltage   | $I_{OH} = -20\text{ }\mu\text{A}$ <sup>[2]</sup>   | $0.7 \times V_{CC}$ | -   | -                    | V             |
| $V_{OL}$   | LOW level output voltage  | $I_{OL} = 1\text{ mA}$   | -                   | -   | 0.3                  | V             |
|            |   | $I_{OL} = 0.5\text{ mA}$   | -                   | -   | $0.15 \times V_{CC}$ | V             |

- [1] IO1/IO2 source a transition current when being externally driven from HIGH to LOW. This transition current ( $I_{TL}$ ) reaches its maximum value when the input voltage  $V_I$  is approximately  $0.5 V_{CC}$ . Current IIL is tested at input voltage  $V_I = 0.3\text{ V}$ .
- [2] External pull-up resistor  $20\text{ k}\Omega$  to  $V_{CC}$  assumed. The worst case test condition for parameter  $V_{OH}$  is present at minimum  $V_{CC}$ .

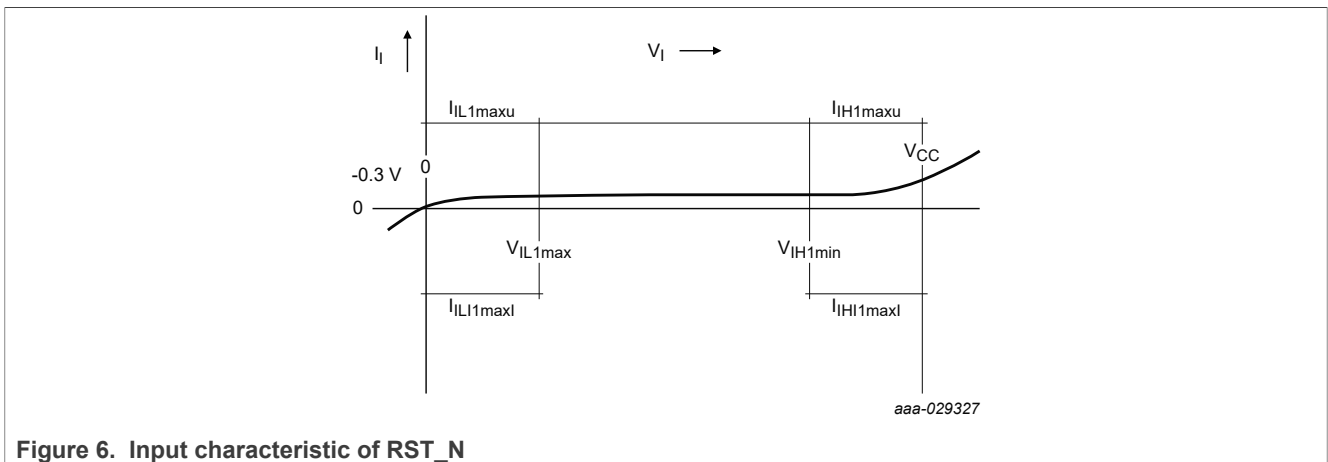

**Figure 6. Input characteristic of RST\_N**

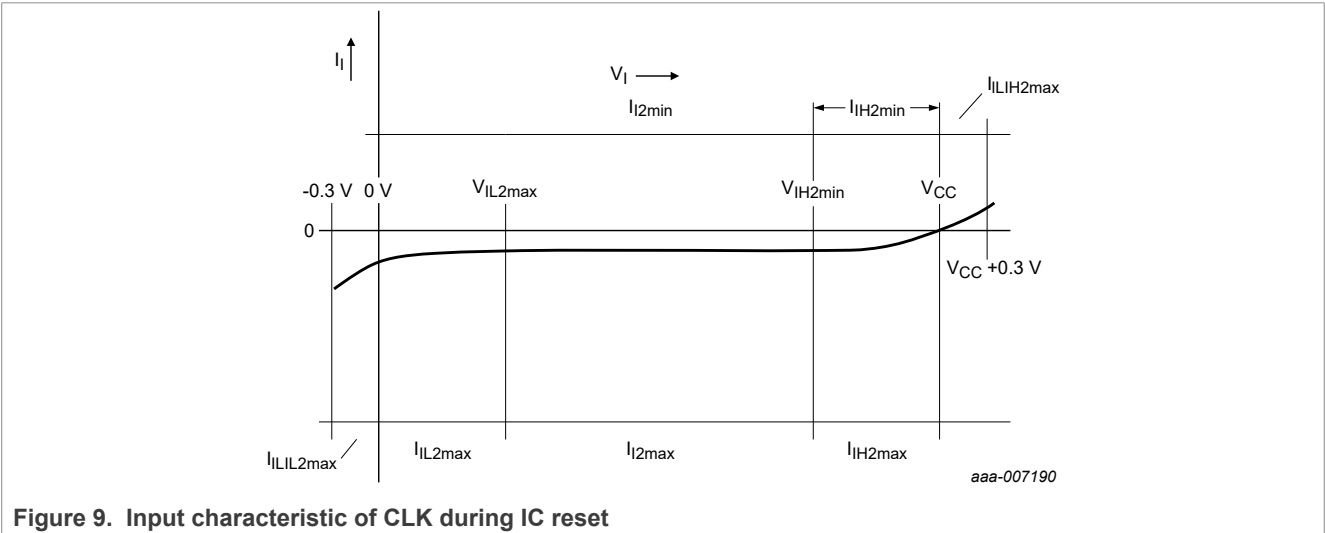
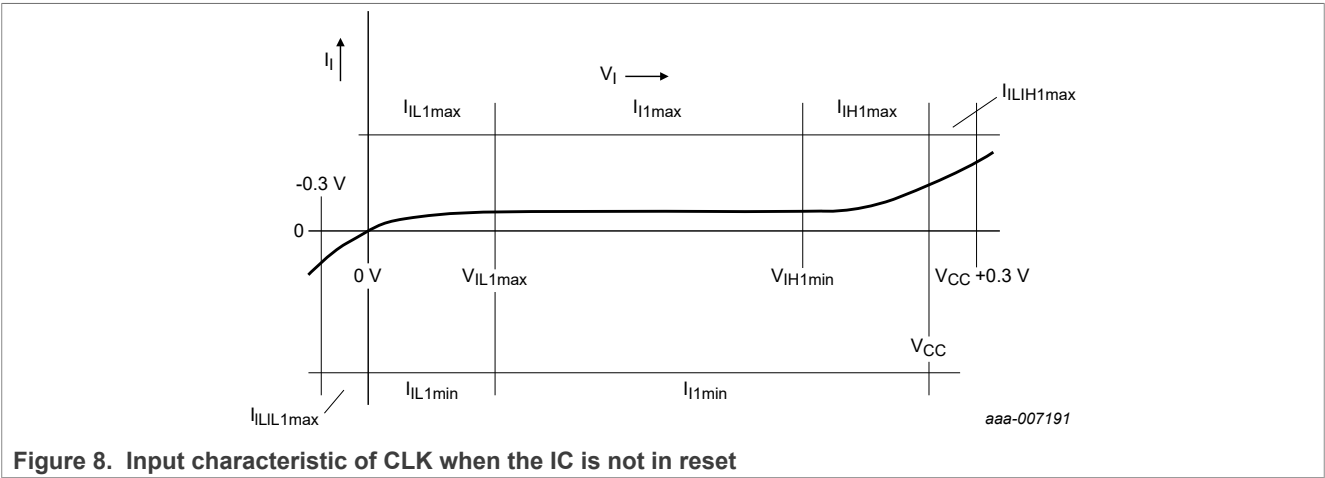
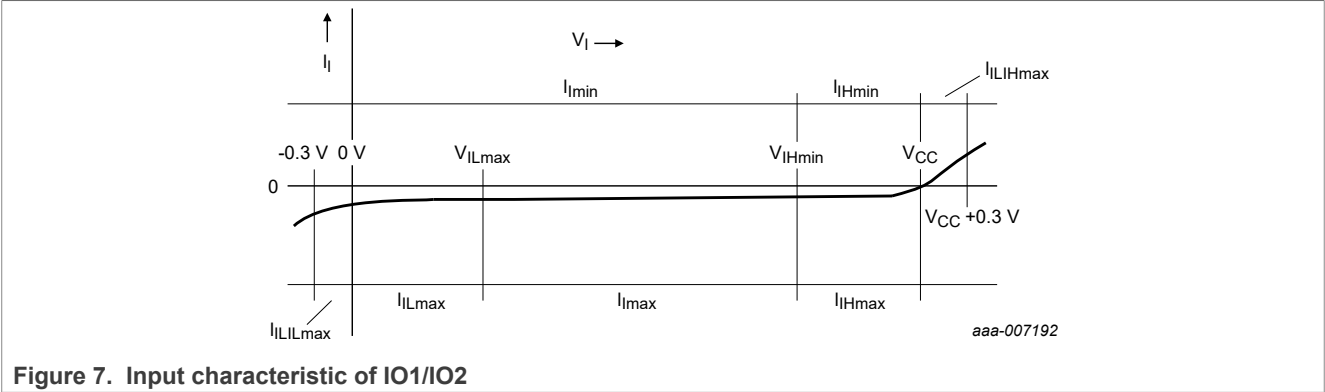

14.1.2 I<sup>2</sup>C Interface

Table 11. Electrical DC characteristics of I<sup>2</sup>C pads SDA, SCL. Conditions: V<sub>CC</sub>, V<sub>IN</sub> = 1.62 V to 3.6 V; V<sub>SS</sub> = 0 V; T<sub>amb</sub> = -40 °C to 105 °C, unless otherwise specified\*

Maximum supported supply voltage is 6 V. In case of supply voltages above 3.6 V, Deep Power-down mode current <5 µA is not guaranteed.

SCL, SDA pads are in open-drain mode.

| Symbol              | Parameter                                  | Conditions   | Min                   | Typ  | Max                    | Unit |
|---------------------|--|--|-----------------------|------|------------------------|------|
| V <sub>IH</sub>     | HIGH level input voltage                   |  | 0.7 × V <sub>in</sub> | -    | V <sub>in</sub> + 0.3  | V    |
| V <sub>IL</sub>     | LOW level input voltage                    |  | -0.3                  | -    | 0.25 × V <sub>in</sub> | V    |
| V <sub>HYS</sub>    | Input hysteresis voltage                   |  | 0.081 V               | -    | -                      | V    |
| V <sub>OL(OD)</sub> | Low level output voltage (open-drain mode) | I <sub>OL</sub> = 3 mA                             | 0                     | -    | 0.4                    | V    |
| I <sub>OL(OD)</sub> | Low level output current (open-drain mode) | V <sub>OL</sub> = 0.6 V                            | 0.6                   | -    | -                      | mA   |
| I <sub>WPU</sub>    | weak pull-up current                       | V <sub>IO</sub> = 0 V                              | -265                  | -180 | -70                    | µA   |
| I <sub>ILIH</sub>   | Leakage input current high level           | V <sub>SDA</sub> = 3.6 V, V <sub>SCL</sub> = 3.6 V | -                     | 0.27 | 15                     | µA   |

14.1.3 Power consumption

Table 12. Electrical characteristics of IC supply voltage V<sub>CC</sub>; V<sub>SS</sub> = 0 V; T<sub>amb</sub> = -40 °C to 105 °C

| Symbol                         | Parameter   | Conditions  | Min  | Typ  | Max  | Unit |
|--------------------------------|---|---|------|------|------|------|
| <b>Supply</b>                  |   |   |      |      |      |      |
| V <sub>CC</sub>                | supply voltage range  | V <sub>CC</sub> = 1.62 V - 3.6 V  | 1.62 | 1.8  | 3.6  | V    |
| I <sub>DD</sub> <sup>[1]</sup> | operating mode: typical CPU, no coprocessor active                                | f <sub>CPU</sub> = 48 MHz, f <sub>MST</sub> = 96 MHz  | -    | 4.4  | 7    | mA   |
|                                | AES coprocessor active (AES 48 MHz)   | CPU in idle mode  | -    | 6.5  | 7.5  | mA   |
|                                | Public Key cryptography Coprocessor active (96 MHz)                               | CPU in idle mode  | -    | 14.4 | 16.1 | mA   |
|                                | DES coprocessor active (DES 48 MHz)   | CPU in idle mode  | -    | 6.5  | 7.6  | mA   |
| I <sub>DD</sub> (PD-ISO7816)   | supply current Power-down mode (ISO7816 clock-stop)                               | V <sub>CC(min)</sub> ≤ V <sub>CC</sub> ≤ V <sub>CC(max)</sub> ; Clock to input CLK stopped, T <sub>amb</sub> = 25 °C  | -    | 430  | 480  | µA   |
| I <sub>DDD</sub> (DPD)         | supply current Deep Power-down mode   | V <sub>CC(min)</sub> ≤ V <sub>IN</sub> ≤ V <sub>CC(max)</sub> ; T <sub>amb</sub> = 25 °C  | -    | 3    | 5    | µA   |
| I <sub>DD</sub> (PD-I2C)       | supply current I <sup>2</sup> C Power-down mode (I <sup>2</sup> C wake-up source) | V <sub>CC(min)</sub> ≤ V <sub>CC</sub> ≤ V <sub>CC(max)</sub> ; Clock to input SCL stopped, T <sub>amb</sub> = 25 °C SDA, SCL pads in pull-up<br>Typical value with V <sub>CC</sub> = 1.8 V | -    | 450  | 500  | µA   |

[1] Maximum current consumption with concurrent AES and Public Key Cryptography 19 mA.

## 14.2 AC characteristics

**Table 13. Non-volatile memory timing characteristics**

Conditions:  $V_{CC} = 1.62\text{ V to }3.6\text{ V}$ ;  $V_{SS} = 0\text{ V}$ ;  $T_{amb} = -40\text{ °C to }105\text{ °C}$ , unless otherwise specified.

| Symbol    | Parameter   | Conditions               | Min              | Typ <sup>[1]</sup> | Max | Unit   |
|-----------|---|--------------------------|------------------|--------------------|-----|--------|
| $t_{EEP}$ | FLASH erase + program time  | [2]                      | -                | 2.3                | -   | ms     |
| $t_{EEE}$ | FLASH erase time  |                          | -                | 1.4                | -   | ms     |
| $t_{EEW}$ | FLASH program time  |                          | -                | 0.9                | -   | ms     |
| $t_{EER}$ | FLASH data retention time   | $T_{amb} = 55\text{ °C}$ | 25               | -                  | -   | years  |
| $N_{EEC}$ | FLASH endurance (maximum number of programming cycles applied to the whole memory block, performed by NXP static and dynamic wear leveling algorithm) |                          | $20 \times 10^6$ | $100 \times 10^6$  | -   | cycles |

[1] Typical values are only referenced for information. They are subject to change without notice.

[2] Given value specifies physical access times of FLASH memory only.

**Table 14. Electrical AC characteristics of I<sup>2</sup>C\_SDA, I<sup>2</sup>C\_SCL, and RST\_N<sup>[1]</sup>;  $V_{CC} = 1.8\text{ V} \pm 10\%$  or  $3\text{ V} \pm 10\%$ ;  $V_{SS} = 0\text{ V}$ ;  $T_{amb} = -40\text{ °C to }105\text{ °C}$**

SCL, SDA pads in open-drain mode.

| Symbol   | Parameter  | Conditions   | Min | Typ | Max  | Unit              |
|--|--|--|-----|-----|------|-------------------|
| <b>Input/Output: I<sup>2</sup>C_SDA, I<sup>2</sup>C_SCL in open-drain mode</b> |  |  |     |     |      |                   |
| $t_{r(i)}$   | input rise time  | Input/reception mode   | [2] | -   | -    | 1 $\mu\text{s}$   |
| $t_{f(i)}$   | input fall time  | Input/reception mode   | [3] | -   | -    | 1 $\mu\text{s}$   |
| $t_{f(o)}$   | output fall time   | Output/transmission mode; $C_L = 30\text{ pF}$                                   | [2] | -   | -    | 0.3 $\mu\text{s}$ |
| $f_{CLK}$  | External clock frequency in I <sup>2</sup> C applications                        | $t_{CLKW}$ , $T_{amb}$ and $V_{CC}$ in their specified limits                    | -   | -   | 3.4  | MHz               |
| $t_{PD}$   | Power down duration time (I <sup>2</sup> C wake-up)                              | CPU clock = 48 MHz   | [4] | -   | 67   | $\mu\text{s}$     |
| $t_{WKPD}$   | Wake-up from power down duration time (I <sup>2</sup> C wake-up)                 | CPU clock = 48 MHz   | [5] | -   | 97   | $\mu\text{s}$     |
| $C_{PIN}$  | Pin capacitances RST_N, I <sup>2</sup> C_SDA, /I <sup>2</sup> C_SCL              | Test frequency = 1 MHz; $T_{amb} = 25\text{ °C}$                                 | -   | -   | 10.5 | pF                |
| $t_{ENalt}$  | ENA low time and $V_{out}$ , $V_{CC}$ low time for entering deep power down mode |  | [6] | -   | 2    | $\mu\text{s}$     |
| $R_{on}$   | Resistance of power switch   | $T_{amb} = 105\text{ °C}$ , $I_{load} = 25\text{ mA}$ , $V_{in} = 1.62\text{ V}$ | -   | -   | 1.1  | $\Omega$          |
| $I_{out}$  | maximum current driving capability of pin $V_{out}$                              | $T_{amb} = 105\text{ °C}$  | -   | -   | 25   | mA                |
| <b>Inputs: RST_N (active only if ISO7816 UART interface is enabled)</b>        |  |  |     |     |      |                   |
| $t_{RW}$   | Reset pulse width (RST_N low) without entering Power-down mode                   |  | 40  | -   | 400  | $\mu\text{s}$     |
| $t_{RDSLP}$  | Reset pulse width (RST_N low) to enter Power-down mode                           |  | 500 | -   | -    | $\mu\text{s}$     |

**Table 14. Electrical AC characteristics of I<sup>2</sup>C\_SDA, I<sup>2</sup>C\_SCL, and RST\_N<sup>[1]</sup>; V<sub>CC</sub> = 1.8 V ± 10 % or 3 V ± 10 % V; V<sub>SS</sub> = 0 V; T<sub>amb</sub> = -40 °C to 105 °C...continued**  
 SCL, SDA pads in open-drain mode.

| Symbol              | Parameter  | Conditions   | Min | Typ | Max  | Unit |
|---------------------|--|--|-----|-----|------|------|
| t <sub>WKP</sub>    | Wake-up time from Power-down mode                                  | f <sub>CLKmin</sub> < f <sub>CLK</sub> < f <sub>CLKmax</sub> | -   | 8   | 10   | µs   |
| t <sub>WKPIO</sub>  | Pad LOW time for wake-up from Power-down mode                      | level triggered ext.int.                                     | -   | 8   | 10   | µs   |
|                     |  | edge triggered ext.int.                                      | -   | 8   | 10   | µs   |
| t <sub>WKPRST</sub> | RST_N LOW time for wake-up from Power-down mode                    |  | 40  | -   | -    | µs   |
| C <sub>PIN</sub>    | Pin capacitances RST_N, I <sup>2</sup> C_SDA, I <sup>2</sup> C_SCL | Test frequency = 1 MHz; T <sub>amb</sub> = 25 °C             | -   | -   | 10.5 | pF   |

- [1] All appropriately marked values are typical values and only referenced for information. They are subject to change without notice.
- [2] t<sub>r</sub> is defined as rise time between 30 % and 70 % of the signal amplitude. t<sub>f</sub> is defined as fall time between 70 % and 30 % of the signal amplitude.
- [3] t<sub>r</sub> is defined as rise time between 30 % and 70 % of the signal amplitude. t<sub>f</sub> is defined as fall time between 70 % and 30 % of the signal amplitude.
- [4] Wakeup from power down: if clock stretching disabled and I<sup>2</sup>C\_SCL=400 kHz; the wakeup time will not be sufficient under the rare condition where host sends the first command during the time where SE is just entering power down; in this case the SE will send an R block to request retransmission from the host
- [5] Wakeup from power down: if clock stretching disabled and I<sup>2</sup>C\_SCL=1 MHz; the wakeup time will not be sufficient to receive the first host command; the SE will send an R block to request retransmission from the host
- [6] Low glitches below 0.4 V on pin ENA and V<sub>in</sub>, V<sub>out</sub>, V<sub>CC</sub> larger than 30 ns cause Power-On-Reset, respectively entering deep power-down mode.

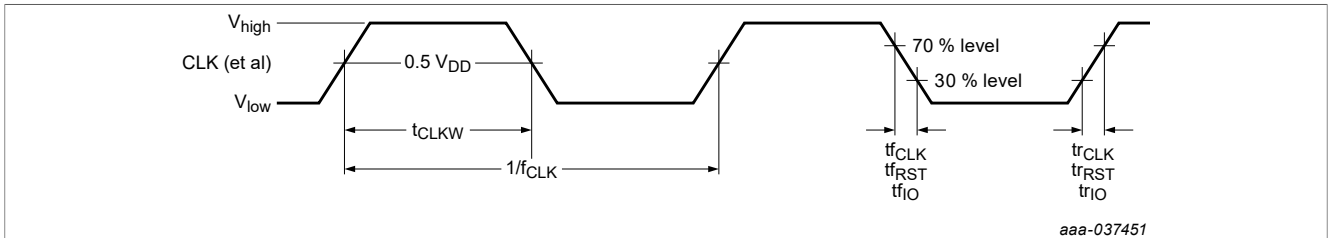

aaa-037451

- <sup>1)</sup> During AC testing the inputs RST\_N, I<sup>2</sup>C\_SDA, I<sup>2</sup>C\_SCL are driven at 0 V to 0.3 V for a LOW input level and at V<sub>CC</sub> - 0.3 V to V<sub>CC</sub> for a HIGH input level. Clock period and signal pulse (duty cycle) timing is measured at 50 % of V<sub>CC</sub>.
- <sup>2)</sup> t<sub>r</sub> is defined as rise time between 30 % and 70 % of the signal amplitude. t<sub>f</sub> is defined as fall time between 70 % and 30 % of the signal amplitude.

**Figure 10. External clock drive and AC test timing reference points of I<sup>2</sup>C\_SDA, I<sup>2</sup>C\_SCL, and RST\_N (see <sup>1)</sup> and <sup>2)</sup>) in open-drain mode**

**Table 15. Electrical AC characteristics of IO1, IO2, CLK and RST\_N (ISO7816 interface)**

Conditions: V<sub>CC</sub> = 1.8 V ± 10 % or 3 V ± 10 % V; V<sub>SS</sub> = 0 V; T<sub>amb</sub> = -40 °C to 105 °C, unless otherwise specified. Typical values are only referenced for information. They are subject to change without notice.

| Symbol                       | Parameter        | Conditions  | Min | Typ | Max                          | Unit |
|------------------------------|------------------|---|-----|-----|------------------------------|------|
| <b>Input/Output: IO1/IO2</b> |                  |   |     |     |                              |      |
| t <sub>r(i)</sub>            | input rise time  | Input/reception mode <sup>[1] [2]</sup>             | -   | -   | 1                            | µs   |
|                              |                  | Input/reception mode <sup>[3] [2]</sup>             | -   | -   | 0.25 x t <sub>IOwx_min</sub> | µs   |
| t <sub>f(i)</sub>            | input fall time  | Input/reception mode <sup>[1] [2]</sup>             | -   | -   | 1                            | µs   |
|                              |                  | Input/reception mode <sup>[3] [2]</sup>             | -   | -   | 0.25 x t <sub>IOwx_min</sub> | µs   |
| t <sub>r(o)</sub>            | output rise time | Output/transmission mode; CL = 30 pF <sup>[2]</sup> | -   | -   | 0.1                          | µs   |
| t <sub>f(o)</sub>            | output fall time | Output/transmission mode; CL = 30 pF <sup>[2]</sup> | -   | -   | 0.1                          | µs   |

**Table 15. Electrical AC characteristics of IO1, IO2, CLK and RST\_N (ISO7816 interface)...***continued*

Conditions:  $V_{CC} = 1.8 V \pm 10 \%$  or  $3 V \pm 10 \% V$ ;  $V_{SS} = 0 V$ ;  $T_{amb} = -40\text{ }^{\circ}\text{C}$  to  $105\text{ }^{\circ}\text{C}$ , unless otherwise specified. Typical values are only referenced for information. They are subject to change without notice.

| Symbol                       | Parameter  | Conditions   | Min  | Typ | Max  | Unit          |
|------------------------------|--|--|------|-----|------|---------------|
| <b>Inputs: CLK and RST_N</b> |  |  |      |     |      |               |
| $f_{CLK}$                    | External clock frequency in ISO/IEC 7816 UART applications               | $t_{CLKW}$ , $t_{amb}$ and $V_{CC}$ in their specified limits <sup>[4]</sup> | 0.85 | -   | 11.5 | MHz           |
| $t_{CLKW}$                   | Clock pulse width i.r.t. clock period (positive pulse duty cycle of CLK) |  | 40   | -   | 60   | %             |
| $t_{r(i)(CLK)}$              | CLK input rise time  | <sup>[5]</sup>   | -    | -   | [6]  |               |
| $t_{f(i)(CLK)}$              | CLK input fall time  | <sup>[2] [6]</sup>   | -    | -   | [6]  |               |
| $t_{r(i)(RST\_N)}$           | RST_N input rise time  | <sup>[2]</sup>   | -    | -   | 400  | $\mu\text{s}$ |
| $t_{f(i)(RST\_N)}$           | RST_N input fall time  | <sup>[2] [7]</sup>   | -    | -   | 400  | $\mu\text{s}$ |

- [1] At minimum IO1 input signal HIGH or LOW level voltage pulse width of 3.2  $\mu\text{s}$ . This timing specification applies to ISO7816 configurations down to a minimum etu duration of 16 CLK cycles at a maximum CLK frequency of 5 MHz ( $TA1=0x96$ ,  $(Fi/Di)=(512/32)$ ), for example.
- [2]  $t_r$  is defined as rise time between 10 % and 90 % of the signal amplitude.
- [3] At minimum IO1 input signal HIGH or LOW level voltage pulse width of less than 3.2  $\mu\text{s}$ . This timing specification applies to ISO7816 configurations beyond the conditions listed in note [2], down to a minimum etu duration of 8 CLK cycles at a maximum CLK frequency of 5 MHz ( $TA1=0x97$ ,  $(Fi/Di)=(512/64)$ ), for example. An 8 CLKs/etu at  $f_{clk} = 5$  MHz configuration results in  $t_{IOw\_x\_min} = 1.6\text{ }\mu\text{s}$ , and in a time of 400 ns for  $t_{rIO\_max}$  and  $t_{fIO\_max}$ , matching the  $(Fi/Di)=(512/64)$  speed enhancement requirements of ETSI TS 102 221.
- [4] ISO/IEC 7816 I/O applications have to supply a clock signal to input CLK in the frequency range of 1 MHz to 10 MHz nominal. A  $\pm 15\%$  tolerance range yields the allowed limits of 0.85 MHz and 11.5 MHz.
- [5] During AC testing the inputs CLK, RST\_N, and IO1 are driven at 0 V to +0.3 V for a LOW input level and at  $V_{CC} - 0.3 V$  to  $V_{CC}$  for a HIGH input level. Clock period and signal pulse (duty cycle) timing is measured at 50 % of  $V_{CC}$ , see [Figure 18](#).
- [6] The maximum CLK rise and fall time is 10 % of the CLK period  $1/f_{CLK}$  - with the following exception: In the CLK frequency range of 1 MHz to 5 MHz the maximum allowed CLK rise and fall time is 50 ns, if 10 % of the CLK period is shorter than 50 ns.
- [7] The ETSI TS102 221/GSM 11.1x specifications specify a maximum reset signal (RST\_N) rise time and fall time of 400,000  $\mu\text{s}$ , respectively.

**Note:** *tf* is defined as fall time between 90 % and 10 % of the signal amplitude.

**Table 16. Electrical AC characteristics of LA, LB; Conditions:  $T_{amb} = -40\text{ }^{\circ}\text{C}$  to  $105\text{ }^{\circ}\text{C}$ , unless otherwise specified**

| Symbol                                   | Parameter   | Conditions                                       | Typ <sup>[1]</sup> | Max | Unit       |
|--|---|--|--------------------|-----|------------|
| <b>Input/Output: LA, LB</b>              |   |  |                    |     |            |
| $C_{LALB}$ <sup>[2]</sup>                | Pin capacitance LA, LB, bare die (SO28 empty package ground-off)  |  |                    |     |            |
|  | Configured for antenna input with 56 pF capacitance, Test frequency = 13.56 MHz; $T_{amb} = 25\text{ }^{\circ}\text{C}$ | $V_{LA,LB} = 2.1 V_{rms}$ <sup>[3] [4]</sup>     | 54.3               | -   | pF         |
| $V_{LA,LB} = 0.3 V_{rms}$ <sup>[4]</sup> |   | 50.1   | -                  | pF  |            |
| $R_{LALB}$ <sup>[2]</sup>                | Configured for antenna input with 56 pF capacitance, test frequency = 13.56 MHz; $T_{amb} = 25\text{ }^{\circ}\text{C}$ | $V_{LA,LB} = 2.1 V_{rms}$ <sup>[3] [4] [5]</sup> | 0.913              | -   | k $\Omega$ |
| $f_{LALB}$                               | Operating frequency LA, LB  | level triggered ext.int.                         | 13.56              | -   | MHz        |

- [1] Typical values ( $\pm 10\%$ ) are only referenced for information. They are subject to change without notice.
- [2] The CLALB and RLALB values stated here assume a parallel RC equivalent circuit for the chip.
- [3] The value stated here was measured at estimated start of chip operation and is comparable to the values stated in other family member data sheets.
- [4] Measured with sine wave at LA, LB.
- [5] Parameter is valid in contactless ISO14443 compliant operation valid only.

### 14.3 I<sup>2</sup>C Bus Timings

Parameters defined in this chapter replace the parameter definitions of I<sup>2</sup>C bus, for specification see [4].

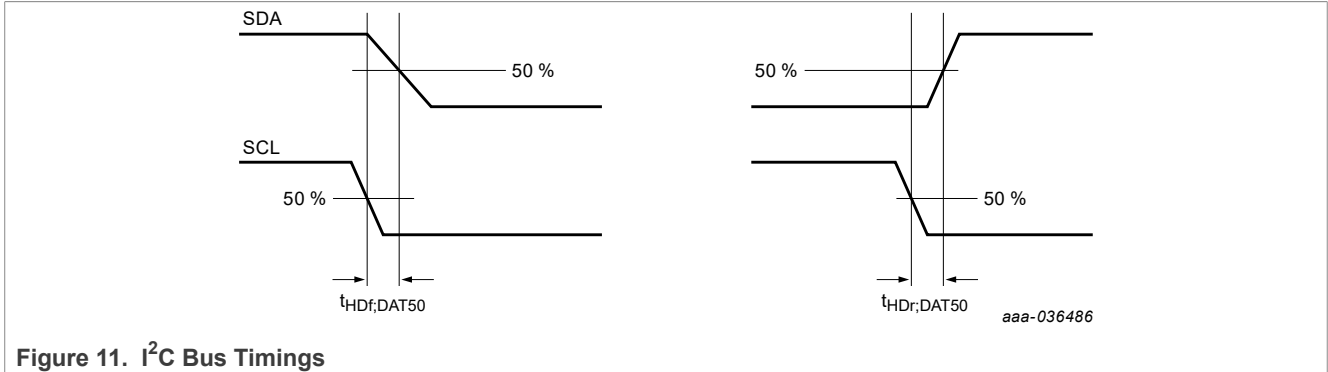

Figure 11. I<sup>2</sup>C Bus Timings

Table 17. I<sup>2</sup>C Bus Timing Specification

| Symbol                                | Parameter                                | Condition | Min | Max | Unit |
|---------------------------------------|--|-----------|-----|-----|------|
| t <sub>HDf,DAT50</sub> <sup>[1]</sup> | data hold time 50 % SCL - 50 % SDA level | Fast mode | 8   | -   | ns   |
| t <sub>HDr,DAT50</sub> <sup>[2]</sup> | data hold time 50 % SCL - 50 % SDA level | Fast mode | 24  | -   | ns   |
| t <sub>HDf,DAT50</sub> <sup>[1]</sup> | data hold time 50 % SCL - 50 % SDA level | Hs mode   | 8   | -   | ns   |
| t <sub>HDr,DAT50</sub> <sup>[2]</sup> | data hold time 50 % SCL - 50 % SDA level | Hs mode   | 9   | -   | ns   |

[1] t<sub>HDf,DAT50</sub>, as defined in Figure 11, replaces parameter t<sub>HD,DAT</sub> defined in [4]

[2] t<sub>HDr,DAT50</sub>, as defined in Figure 11, replaces parameter t<sub>HD,DAT</sub> defined in [4]

### 14.4 EMC/EMI

EMC and EMI resistance according to IEC 61967-4.

## 15 Abbreviations

Table 18. Abbreviations

| Acronym          | Description   |
|------------------|---|
| AES              | Advanced Encryption Standard                          |
| APDU             | Application Protocol Data Unit                        |
| CL               | Contactless   |
| CLK              | External clock signal input contact pad               |
| CC               | Common Criteria                                       |
| CMAC             | Cipher-based MAC                                      |
| CRC              | Cyclic Redundancy Check                               |
| CRI              | Cryptography Research Incorporated                    |
| DES              | Digital Encryption Standard                           |
| DPA              | Differential Power Analysis                           |
| DSS              | Digital Signature Standard                            |
| EAL              | Evaluation Assurance Level                            |
| ECC              | Elliptic Curve Cryptography                           |
| EMC              | Electromagnetic compatibility                         |
| EMI              | Electro Magnetic Immunity                             |
| FM               | Fast-Mode   |
| FM+              | Fast-Mode+  |
| GP               | Global Platform                                       |
| GPIO             | General-purpose input/output                          |
| HS               | High-Speed-Mode                                       |
| HKDF             | HMAC-based Extract-and-Expand Key Derivation Function |
| HMAC             | Keyed-Hash Message Authentication Code                |
| HW               | Hardware  |
| IC               | Integrated Circuit                                    |
| I <sup>2</sup> C | Inter-Integrated Circuit                              |
| I/O              | Input/Output  |
| IoT              | Internet of Things                                    |
| JCOP             | Java Card Open Platform                               |
| LA               | ISO 14443 Antenna Pad                                 |
| LB               | ISO 14443 Antenna Pad                                 |
| NFC              | Near Field Communication                              |
| MAC              | Message Authentication Code                           |
| MCU              | Microcontroller unit                                  |
| MPU              | Microprocessor  |

Table 18. Abbreviations...continued

| Acronym          | Description                                     |
|------------------|---|
| MW               | Middleware                                      |
| OS               | Operating System                                |
| NIST             | National Institute for Standards and Technology |
| PCB              | printed circuit board                           |
| PKI              | Public Key Infrastructure                       |
| PRF              | Pseudo Random Function                          |
| RAM              | Random Access Memory                            |
| RSA              | Rivest-Shamir-Adleman                           |
| RST              | Reset   |
| SAM              | Secure Access Module                            |
| SCL              | Serial clock                                    |
| SDA              | Serial data                                     |
| SPA              | Simple Power Analysis                           |
| SFI              | Single Fault Injection                          |
| SHA              | Secure Hash Algorithm                           |
| SW               | Software  |
| TLS              | Transport Layer Security                        |
| V <sub>CC</sub>  | Supply Voltage Input                            |
| V <sub>in</sub>  | Input voltage                                   |
| V <sub>out</sub> | output voltage                                  |
| V <sub>SS</sub>  | Ground  |

## 16 References

---

- [1] NXP SE05x T=1 Over I<sup>2</sup>C Specification User manual, document number UM11225. Available on [NXP website](#)
- [2] SOT1969-1; HX2QFN20; Reel packing and package information. Available on [NXP website](#)
- [3] SE050 IoT Applet APDU Specification, document number AN 12413. Available on [NXP website](#)
- [4] SE050 configurations Application Note, document number AN12436. Available on [NXP website](#)
- [5] SE050 Use and Security Guidelines Application Note, document number AN12514. Availavle on [NXP website](#).

## 17 Revision history

Table 19. Revision history

| Document ID   | Release date   | Data sheet status  | Change notice | Supersedes |
|---------------|--|--------------------|---------------|------------|
| SE050 v.3.8   | 20231018   | Product data sheet | -             | 504937     |
| Modifications | <ul style="list-style-type: none"> <li>Corrected a typo in the second paragraph after <a href="#">Table 5</a> ISO1816 must be ISO7816</li> <li>Adjusted the timing value in <a href="#">Table 1</a> the value of the erase time and program time where switched around</li> <li>Corrected the layout of some tables</li> <li>Corrected the notation of some symbols, and added a space where mandatory</li> <li>updated the legal information</li> </ul> |                    |               |            |
| 504937        | 2022-10-27   | Product data sheet |               | 504936     |
| Modifications | <ul style="list-style-type: none"> <li>Update <a href="#">Section 3.1.1</a></li> </ul>   |                    |               |            |
| 504936        | 2022-08-24   | Product data sheet |               | 504935     |
| Modifications | <ul style="list-style-type: none"> <li>Update <a href="#">Section 3.1.1</a></li> </ul>   |                    |               |            |
| 504935        | 2022-08-22   | Product data sheet |               | 504934     |
| Modifications | <ul style="list-style-type: none"> <li>Update <a href="#">Section 2.3</a></li> </ul>   |                    |               |            |
| 504934        | 2022-03-28   | Product data sheet |               | 504933     |
| Modifications | <ul style="list-style-type: none"> <li>Update <a href="#">Section 1.3</a></li> <li>Update <a href="#">Section 2.2</a></li> <li>Update <a href="#">Section 2.3</a></li> <li>Update <a href="#">Section 4.1</a></li> <li>Update <a href="#">Section 4.1.1</a></li> <li>Update <a href="#">Section 6.1</a></li> <li>Update <a href="#">Table 3</a></li> <li>Update <a href="#">Figure 2</a></li> </ul>  |                    |               |            |
| 504933        | 2021-07-01   | Product data sheet |               | 504932     |
| Modifications | <ul style="list-style-type: none"> <li>Insert SE050F2 variant to <a href="#">Table 3</a></li> </ul>  |                    |               |            |
| 504932        | 2021-05-05   | Product data sheet |               | 504931     |
| Modifications | <ul style="list-style-type: none"> <li>updated <a href="#">Section 2.2</a></li> <li>updated <a href="#">Table 2</a></li> <li>Moved technical information on secure objects in <a href="#">Section 3.1.2</a> to the APDU specification <a href="#">[3]</a></li> <li>Replace "master/slave" with "controller/target"</li> <li>updated <a href="#">Figure 1</a></li> <li>Updated references</li> </ul>  |                    |               |            |
| 504931        | 2020-12-15   | Product data sheet |               | 504930     |
| Modifications | <ul style="list-style-type: none"> <li>updated <a href="#">Figure 2</a></li> <li>updated legal information</li> <li>corrected <a href="#">Section 1.3</a></li> </ul>   |                    |               |            |

Table 19. Revision history...continued

| Document ID   | Release date  | Data sheet status    | Change notice | Supersedes |
|---------------|---|----------------------|---------------|------------|
| 504930        | 2020-05-12  | Product data sheet   |               | 504913     |
| Modifications | <ul style="list-style-type: none"> <li>• updated: <a href="#">Section 7.1.1</a></li> <li>• updated: <a href="#">Table 6</a></li> <li>• updated: <a href="#">Section 2.3</a></li> <li>• added <a href="#">Section 3.4</a></li> <li>• added <a href="#">Figure 3</a></li> <li>• added <a href="#">Section 14.3</a></li> <li>• updated <a href="#">Section 12</a></li> <li>• updated <a href="#">Section 14.1.3</a></li> <li>• updated <a href="#">Section 14.2</a></li> <li>• updated <a href="#">Section 14.1.2</a></li> <li>• updated <a href="#">Section 13</a></li> </ul> |                      |               |            |
| 504913        | 20190607  | Objective data sheet |               | 504912     |
| 504912        | 20190510  | Objective data sheet |               | 504911     |
| 504911        | 20181122  | Objective data sheet |               |            |

## 18 Legal information

### 18.1 Data sheet status

| Document status <sup>[1][2]</sup> | Product status <sup>[3]</sup> | Definition  |
|-----------------------------------|-------------------------------|---|
| Objective [short] data sheet      | Development                   | This document contains data from the objective specification for product development. |
| Preliminary [short] data sheet    | Qualification                 | This document contains data from the preliminary specification.                       |
| Product [short] data sheet        | Production                    | This document contains the product specification.                                     |

[1] Please consult the most recently issued document before initiating or completing a design.

[2] The term 'short data sheet' is explained in section "Definitions".

[3] The product status of device(s) described in this document may have changed since this document was published and may differ in case of multiple devices. The latest product status information is available on the Internet at URL <http://www.nxp.com>.

### 18.2 Definitions

**Draft** — A draft status on a document indicates that the content is still under internal review and subject to formal approval, which may result in modifications or additions. NXP Semiconductors does not give any representations or warranties as to the accuracy or completeness of information included in a draft version of a document and shall have no liability for the consequences of use of such information.

**Short data sheet** — A short data sheet is an extract from a full data sheet with the same product type number(s) and title. A short data sheet is intended for quick reference only and should not be relied upon to contain detailed and full information. For detailed and full information see the relevant full data sheet, which is available on request via the local NXP Semiconductors sales office. In case of any inconsistency or conflict with the short data sheet, the full data sheet shall prevail.

**Product specification** — The information and data provided in a Product data sheet shall define the specification of the product as agreed between NXP Semiconductors and its customer, unless NXP Semiconductors and customer have explicitly agreed otherwise in writing. In no event however, shall an agreement be valid in which the NXP Semiconductors product is deemed to offer functions and qualities beyond those described in the Product data sheet.

### 18.3 Disclaimers

**Limited warranty and liability** — Information in this document is believed to be accurate and reliable. However, NXP Semiconductors does not give any representations or warranties, expressed or implied, as to the accuracy or completeness of such information and shall have no liability for the consequences of use of such information. NXP Semiconductors takes no responsibility for the content in this document if provided by an information source outside of NXP Semiconductors.

In no event shall NXP Semiconductors be liable for any indirect, incidental, punitive, special or consequential damages (including - without limitation - lost profits, lost savings, business interruption, costs related to the removal or replacement of any products or rework charges) whether or not such damages are based on tort (including negligence), warranty, breach of contract or any other legal theory.

Notwithstanding any damages that customer might incur for any reason whatsoever, NXP Semiconductors' aggregate and cumulative liability towards customer for the products described herein shall be limited in accordance with the Terms and conditions of commercial sale of NXP Semiconductors.

**Right to make changes** — NXP Semiconductors reserves the right to make changes to information published in this document, including without limitation specifications and product descriptions, at any time and without notice. This document supersedes and replaces all information supplied prior to the publication hereof.

**Suitability for use** — NXP Semiconductors products are not designed, authorized or warranted to be suitable for use in life support, life-critical or safety-critical systems or equipment, nor in applications where failure or malfunction of an NXP Semiconductors product can reasonably be expected to result in personal injury, death or severe property or environmental damage. NXP Semiconductors and its suppliers accept no liability for inclusion and/or use of NXP Semiconductors products in such equipment or applications and therefore such inclusion and/or use is at the customer's own risk.

**Applications** — Applications that are described herein for any of these products are for illustrative purposes only. NXP Semiconductors makes no representation or warranty that such applications will be suitable for the specified use without further testing or modification.

Customers are responsible for the design and operation of their applications and products using NXP Semiconductors products, and NXP Semiconductors accepts no liability for any assistance with applications or customer product design. It is customer's sole responsibility to determine whether the NXP Semiconductors product is suitable and fit for the customer's applications and products planned, as well as for the planned application and use of customer's third party customer(s). Customers should provide appropriate design and operating safeguards to minimize the risks associated with their applications and products.

NXP Semiconductors does not accept any liability related to any default, damage, costs or problem which is based on any weakness or default in the customer's applications or products, or the application or use by customer's third party customer(s). Customer is responsible for doing all necessary testing for the customer's applications and products using NXP Semiconductors products in order to avoid a default of the applications and the products or of the application or use by customer's third party customer(s). NXP does not accept any liability in this respect.

**Limiting values** — Stress above one or more limiting values (as defined in the Absolute Maximum Ratings System of IEC 60134) will cause permanent damage to the device. Limiting values are stress ratings only and (proper) operation of the device at these or any other conditions above those given in the Recommended operating conditions section (if present) or the Characteristics sections of this document is not warranted. Constant or repeated exposure to limiting values will permanently and irreversibly affect the quality and reliability of the device.

**Terms and conditions of commercial sale** — NXP Semiconductors products are sold subject to the general terms and conditions of commercial sale, as published at <http://www.nxp.com/profile/terms>, unless otherwise agreed in a valid written individual agreement. In case an individual agreement is concluded only the terms and conditions of the respective agreement shall apply. NXP Semiconductors hereby expressly objects to applying the customer's general terms and conditions with regard to the purchase of NXP Semiconductors products by customer.

**No offer to sell or license** — Nothing in this document may be interpreted or construed as an offer to sell products that is open for acceptance or the grant, conveyance or implication of any license under any copyrights, patents or other industrial or intellectual property rights.

**Quick reference data** — The Quick reference data is an extract of the product data given in the Limiting values and Characteristics sections of this document, and as such is not complete, exhaustive or legally binding.

**Export control** — This document as well as the item(s) described herein may be subject to export control regulations. Export might require a prior authorization from competent authorities.

**Suitability for use in non-automotive qualified products** — Unless this document expressly states that this specific NXP Semiconductors product is automotive qualified, the product is not suitable for automotive use. It is neither qualified nor tested in accordance with automotive testing or application requirements. NXP Semiconductors accepts no liability for inclusion and/or use of non-automotive qualified products in automotive equipment or applications.

In the event that customer uses the product for design-in and use in automotive applications to automotive specifications and standards, customer (a) shall use the product without NXP Semiconductors' warranty of the product for such automotive applications, use and specifications, and (b) whenever customer uses the product for automotive applications beyond NXP Semiconductors' specifications such use shall be solely at customer's own risk, and (c) customer fully indemnifies NXP Semiconductors for any liability, damages or failed product claims resulting from customer design and use of the product for automotive applications beyond NXP Semiconductors' standard warranty and NXP Semiconductors' product specifications.

**Translations** — A non-English (translated) version of a document, including the legal information in that document, is for reference only. The English version shall prevail in case of any discrepancy between the translated and English versions.

**Security** — Customer understands that all NXP products may be subject to unidentified vulnerabilities or may support established security standards or specifications with known limitations. Customer is responsible for the design and operation of its applications and products throughout their lifecycles to reduce the effect of these vulnerabilities on customer's applications and products. Customer's responsibility also extends to other open and/or proprietary technologies supported by NXP products for use in customer's applications. NXP accepts no liability for any vulnerability. Customer should regularly check security updates from NXP and follow up appropriately. Customer shall select products with security features that best meet rules, regulations, and standards of the intended application and make the ultimate design decisions regarding its products and is solely responsible for compliance with all legal, regulatory, and security related requirements concerning its products, regardless of any information or support that may be provided by NXP.

NXP has a Product Security Incident Response Team (PSIRT) (reachable at [PSIRT@nxp.com](mailto:PSIRT@nxp.com)) that manages the investigation, reporting, and solution release to security vulnerabilities of NXP products.

**NXP B.V.** — NXP B.V. is not an operating company and it does not distribute or sell products.

## 18.4 Trademarks

Notice: All referenced brands, product names, service names, and trademarks are the property of their respective owners.

**NXP** — wordmark and logo are trademarks of NXP B.V.

**EdgeLock** — is a trademark of NXP B.V.

**I2C-bus** — logo is a trademark of NXP B.V.

**JCOP** — is a trademark of NXP B.V.

**MIFARE** — is a trademark of NXP B.V.

## Tables

|          |   |    |          |  |    |
|----------|---|----|----------|--|----|
| Tab. 1.  | SE050 commercial name format .....  | 2  | Tab. 12. | Electrical characteristics of IC supply voltage VCC; VSS = 0 V; Tamb = -40 °C to 105 °C .....  | 17 |
| Tab. 2.  | Feature Overview .....  | 4  | Tab. 13. | Non-volatile memory timing characteristics .....   | 18 |
| Tab. 3.  | SE050 Ordering information .....  | 10 | Tab. 14. | Electrical AC characteristics of I2C_SDA, I2C_SCL, and RST_N; VCC = 1.8 V ± 10 % or 3 V ± 10 % V; VSS = 0 V; Tamb = -40 °C to 105 °C ..... | 18 |
| Tab. 4.  | SE050 Ordering information for development kit .....  | 10 | Tab. 15. | Electrical AC characteristics of IO1, IO2, CLK and RST_N (ISO7816 interface) .....   | 19 |
| Tab. 5.  | Pin description HX2QFN20 .....  | 11 | Tab. 16. | Electrical AC characteristics of LA, LB; Conditions: Tamb = -40 °C to 105 °C, unless otherwise specified .....                             | 20 |
| Tab. 6.  | Marking codes .....   | 12 | Tab. 17. | I2C Bus Timing Specification .....   | 21 |
| Tab. 7.  | Reel packing options .....  | 12 | Tab. 18. | Abbreviations .....  | 22 |
| Tab. 8.  | Limiting values .....   | 13 | Tab. 19. | Revision history .....   | 25 |
| Tab. 9.  | Recommended operating conditions .....  | 13 |          |  |    |
| Tab. 10. | Electrical DC characteristics of Input/Output: IO1/IO2. Conditions: VCC = 1.62 V to 3.6 V (see ; VSS = 0 V; Tamb = -40 °C to 105 °C, unless otherwise specified ..... | 14 |          |  |    |
| Tab. 11. | Electrical DC characteristics of I2C pads SDA, SCL. Conditions: VCC, VIN = 1.62 V to 3.6 V; VSS = 0 V; Tamb = -40 °C to 105 °C, unless otherwise specified* .....     | 17 |          |  |    |

## Figures

|         |   |    |          |  |    |
|---------|---|----|----------|--|----|
| Fig. 1. | SE050 solution block diagram .....                  | 2  | Fig. 8.  | Input characteristic of CLK when the IC is not in reset .....  | 16 |
| Fig. 2. | SE050 functional diagram .....                      | 6  | Fig. 9.  | Input characteristic of CLK during IC reset .....  | 16 |
| Fig. 3. | target address .....                                | 8  | Fig. 10. | External clock drive and AC test timing reference points of I2C_SDA, I2C_SCL, and RST_N (see 1) and 2)) in open-drain mode ..... | 19 |
| Fig. 4. | Pin configuration for HX2QFN20 (SOT1969-1) .....    | 11 | Fig. 11. | I2C Bus Timings .....  | 21 |
| Fig. 5. | Characteristic supply voltage operating range ..... | 14 |          |  |    |
| Fig. 6. | Input characteristic of RST_N .....                 | 15 |          |  |    |
| Fig. 7. | Input characteristic of IO1/IO2 .....               | 16 |          |  |    |



## Contents

|           |  |           |
|-----------|--|-----------|
| <b>1</b>  | <b>Introduction</b> .....                            | <b>1</b>  |
| 1.1       | SE050 use cases .....                                | 1         |
| 1.2       | SE050 target applications .....                      | 2         |
| 1.3       | SE050 naming convention .....                        | 2         |
| <b>2</b>  | <b>Features and benefits</b> .....                   | <b>3</b>  |
| 2.1       | Key benefits .....                                   | 3         |
| 2.2       | Key features .....                                   | 3         |
| 2.3       | Features in detail .....                             | 4         |
| <b>3</b>  | <b>Functional description</b> .....                  | <b>6</b>  |
| 3.1       | Functional diagram .....                             | 6         |
| 3.1.1     | Random number generator .....                        | 6         |
| 3.1.2     | Supported secure object types .....                  | 7         |
| 3.1.3     | Access control .....                                 | 7         |
| 3.1.4     | Sessions and multi-threading .....                   | 7         |
| 3.1.5     | Attestation and trust provisioning .....             | 7         |
| 3.1.6     | Application support .....                            | 7         |
| 3.2       | Credential Storage & Memory .....                    | 8         |
| 3.3       | Preprovisioned "Ease of Use"<br>configurations ..... | 8         |
| 3.4       | Startup behavior .....                               | 8         |
| <b>4</b>  | <b>Communication interfaces</b> .....                | <b>8</b>  |
| 4.1       | I2C Interfaces .....                                 | 8         |
| 4.1.1     | Supported I2C frequencies .....                      | 9         |
| 4.2       | ISO7816 and ISO14443 Interface .....                 | 9         |
| <b>5</b>  | <b>Power-saving modes</b> .....                      | <b>9</b>  |
| 5.1       | Power-down mode .....                                | 9         |
| 5.2       | Deep Power-down mode .....                           | 9         |
| <b>6</b>  | <b>Ordering information</b> .....                    | <b>10</b> |
| 6.1       | Ordering options .....                               | 10        |
| 6.2       | Ordering SE050 samples .....                         | 10        |
| 6.3       | Configuration .....                                  | 10        |
| <b>7</b>  | <b>Pinning information</b> .....                     | <b>11</b> |
| 7.1       | Pinning .....  | 11        |
| 7.1.1     | Pinning HX2QFN20 .....                               | 11        |
| <b>8</b>  | <b>Package</b> .....                                 | <b>12</b> |
| <b>9</b>  | <b>Marking</b> .....                                 | <b>12</b> |
| <b>10</b> | <b>Packing information</b> .....                     | <b>12</b> |
| 10.1      | Reel packing .....                                   | 12        |
| <b>11</b> | <b>Electrical and timing characteristics</b> .....   | <b>13</b> |
| <b>12</b> | <b>Limiting values</b> .....                         | <b>13</b> |
| <b>13</b> | <b>Recommended operating conditions</b> .....        | <b>13</b> |
| <b>14</b> | <b>Characteristics</b> .....                         | <b>14</b> |
| 14.1      | DC characteristics .....                             | 14        |
| 14.1.1    | General and General Purpose I/O interface .....      | 14        |
| 14.1.2    | I2C Interface .....                                  | 17        |
| 14.1.3    | Power consumption .....                              | 17        |
| 14.2      | AC characteristics .....                             | 18        |
| 14.3      | I2C Bus Timings .....                                | 21        |
| 14.4      | EMC/EMI .....  | 21        |
| <b>15</b> | <b>Abbreviations</b> .....                           | <b>22</b> |
| <b>16</b> | <b>References</b> .....                              | <b>24</b> |
| <b>17</b> | <b>Revision history</b> .....                        | <b>25</b> |
| <b>18</b> | <b>Legal information</b> .....                       | <b>27</b> |

Please be aware that important notices concerning this document and the product(s) described herein, have been included in section 'Legal information'.

## Looking for pricing, stock, or lifecycle information?

Click below to explore more details on WIN SOURCE:

-  [View TLP3553A\(F on WIN SOURCE](#)
-  [Toshiba Semiconductor and Storage Information](#)

## Optimize Your Supply Chain with WIN SOURCE Solutions

-  Global Sourcing Solution
-  Obsolete Management
-  Cost Control Management
-  Shortage Management
-  Alternative Solution
-  Excess Inventory Management