



THE DATASHEET OF SMBJ5338B



RAA489118

Buck-Boost Battery Charger with SMBus Interface for General 30V and USB PD EPR

The [RAA489118](#) is a buck-boost charger supporting 30V input and 30V battery. The RAA489118 provides charging and protection features for power tools, portable vacuums, battery-powered lawn mowers, power banks, and additional system bus regulation for notebooks. It also supports any USB-C interface platform including USB PD EPR. The advanced Renesas R3™ technology provides highly efficient light-load operation and fast transient response.

In Charging mode, the RAA489118 accepts input power from a wide range of DC power sources (such as conventional AC/DC charger adapters, USB PD ports, and travel adapters) and safely charges battery packs with up to 7 serially connected battery cells up to 30V. The device can operate with only a battery, only an adapter, or with both connected.

The RAA489118 supports reverse buck, reverse boost, or reverse buck-boost operation to the input port from 2-cell to 7-cell batteries.

The RAA489118 provides programming resistor options including autonomous charging, max output voltages, adapter current limit. Additionally, it provides serial communication that enables programming of many critical parameters to deliver a customized solution.

Features

- Buck-boost charger for 2 to 7-cell up to 30V batteries
- Optional BFET
- Input voltage range: 3.9V to 30V (no dead zone)
- System output voltage: 2.4V to 30.8V
- Autonomous charging option (automatic completion of charging)
- Pass-Through mode in forward direction
- Adapter current and battery current monitor (AMON/BMON)
- Trickle charging of depleted battery
- Reverse buck, boost, and buck-boost operation from battery
- Battery Ship mode option
- 4x4 32 Ld TQFN package compatible with the ISL9238/RAA489108 family of parts

Applications

- Standalone battery charging for 2 to 7-cell batteries, including batteries for power tools, portable vacuums, battery-powered lawn mowers, drones
- 2-cell to 7-cell tablets, Ultrabooks, notebooks, power banks, and any USB-C interface portable device requiring batteries

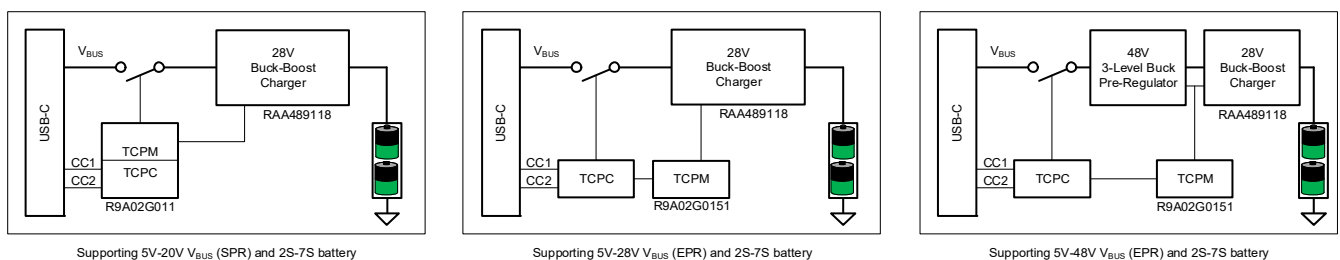

Figure 1. Full-Featured Architecture Solutions Enabled by RAA489118

Contents

- 1. Overview** **4**
 - 1.1 Typical Application Diagram 4
 - 1.2 Block Diagram 6
- 2. Pin Information** **7**
 - 2.1 Pin Assignments 7
 - 2.2 Pin Descriptions 7
- 3. Specifications** **10**
 - 3.1 Absolute Maximum Ratings 10
 - 3.2 Recommended Operating Conditions 10
 - 3.3 Thermal Specifications 11
 - 3.4 Electrical Specifications 11
 - 3.5 SMBus Timing Specification 19
 - 3.6 Gate Driver Timing Diagrams 20
- 4. Typical Performance Graphs** **21**
 - 4.1 Battery Charging Only (No BFET) 21
 - 4.2 NVDC Charging (with BFET) 23
- 5. General SMBus Architecture** **26**
 - 5.1 Data Validity 26
 - 5.2 START and STOP Conditions 26
 - 5.3 Acknowledge 27
 - 5.4 SMBus Transactions 27
 - 5.5 Byte Format 27
 - 5.6 SMBus and I²C Compatibility 28
 - 5.7 SMBus Commands 28
- 6. Registers** **29**
 - 6.1 Register Summary 29
 - 6.2 DAC Register Summary 31
 - 6.3 Control Registers 32
 - 6.4 Information Registers 41
- 7. Modulator Information** **44**
 - 7.1 RAA489118 Buck-Boost Charger Modes of Operation 44
 - 7.2 USB On-the-Go (USB OTG) 45
 - 7.3 Pass-Through Mode 46
 - 7.4 Modulator Control Loops 46
 - 7.5 R3 Modulator 50
- 8. Application Information** **52**
 - 8.1 Soft-Start 52
 - 8.2 Charging Mode Configuration 53
 - 8.3 Programming Charger Option 53
 - 8.4 Autonomous Charging Mode 55
 - 8.5 Battery Ship Mode 55
 - 8.6 Diode Emulation Operation 55
 - 8.7 Battery Learn Mode 56
 - 8.8 Charger Timeout 56

8.9	Monitoring	56
8.10	Stand-Alone Comparator	58
8.11	Protections	59
8.12	Selecting the Power Source	60
9.	General Application Information	61
9.1	Selecting the LC Output Filter	61
9.2	Selecting the Input Capacitor	62
9.3	Selecting the Switching Power MOSFET	62
9.4	Selecting the Bootstrap Capacitor	63
9.5	Switching Power MOSFET Gate Capacitance	63
9.6	DCIN Filter	64
9.7	Adapter Input Filter	64
10.	Layout	65
11.	Package Outline Drawing	68
12.	Ordering Information	68
13.	Revision History	68
A.	ECAD Design Information	69
A.1	Part Number Indexing	69
A.2	Symbol Pin Information	69
A.3	Symbol Parameters	71
A.4	Footprint Design Information	72

1. Overview

1.1 Typical Application Diagram

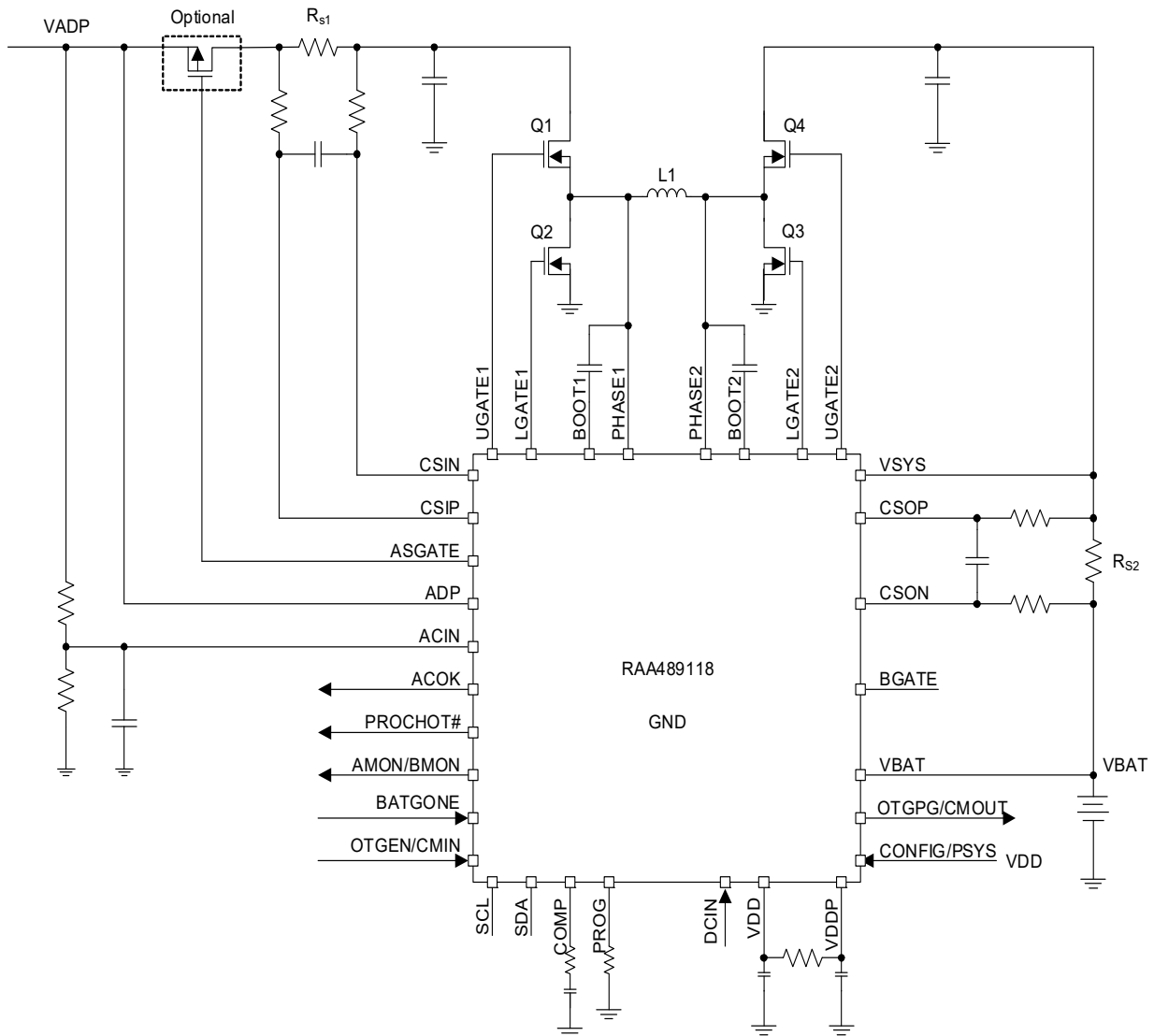

Figure 2. Typical Application Circuit #1 (Battery Charging Only with No BFET)

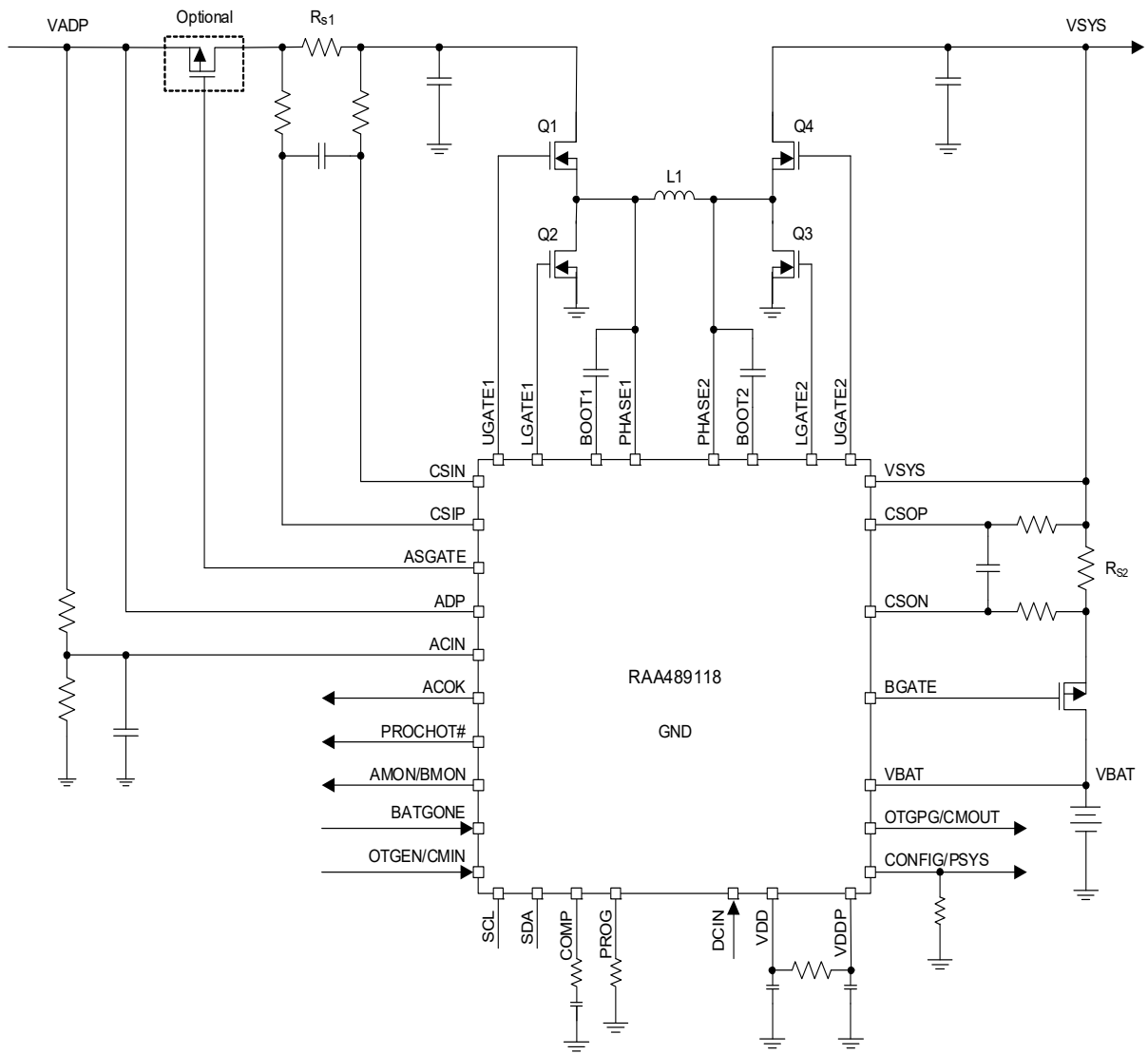

Figure 3. Typical Application Circuit #2 (NVDC Charging with a BFET)

1.2 Block Diagram

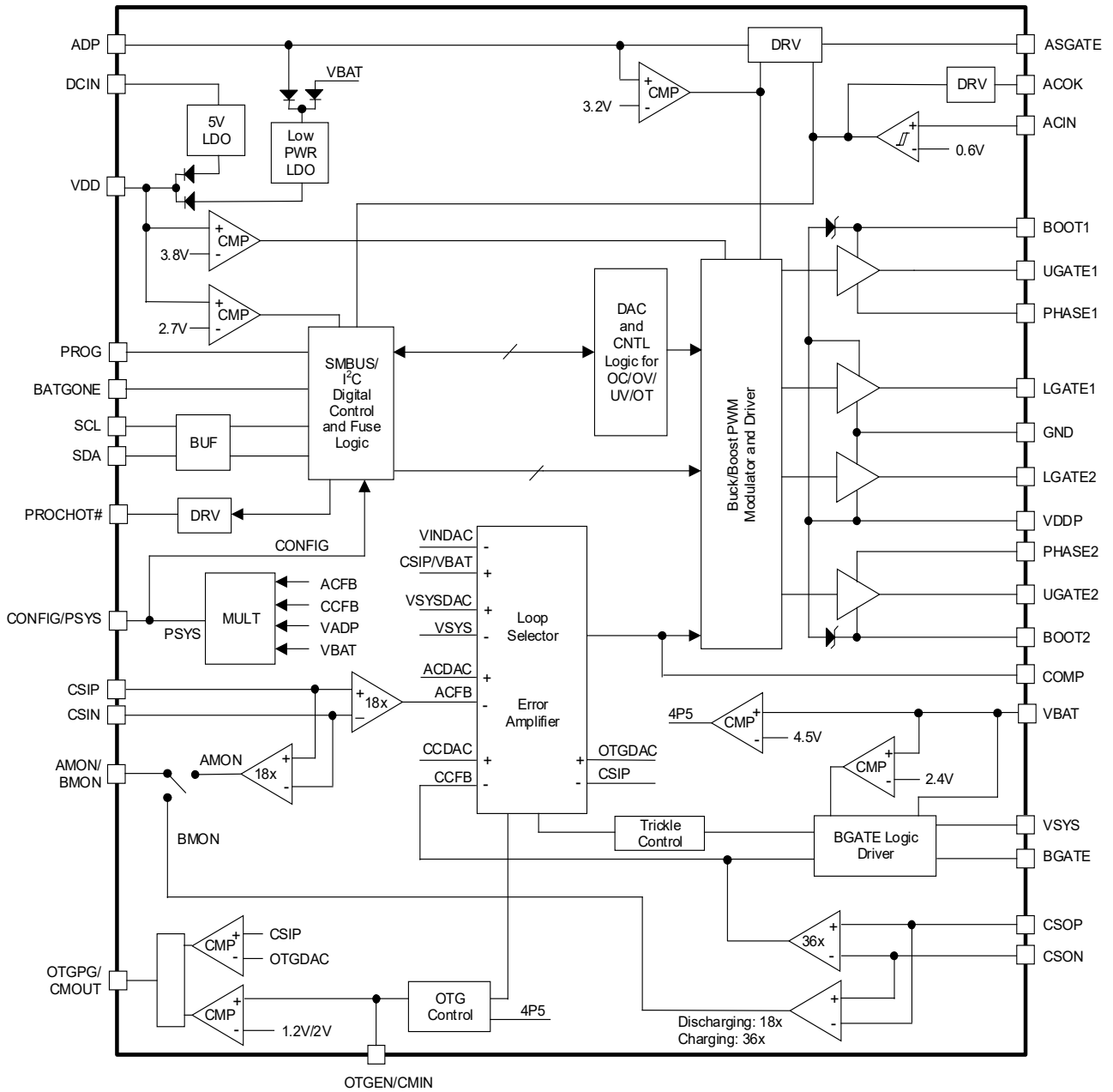

Figure 4. Block Diagram

2. Pin Information

2.1 Pin Assignments

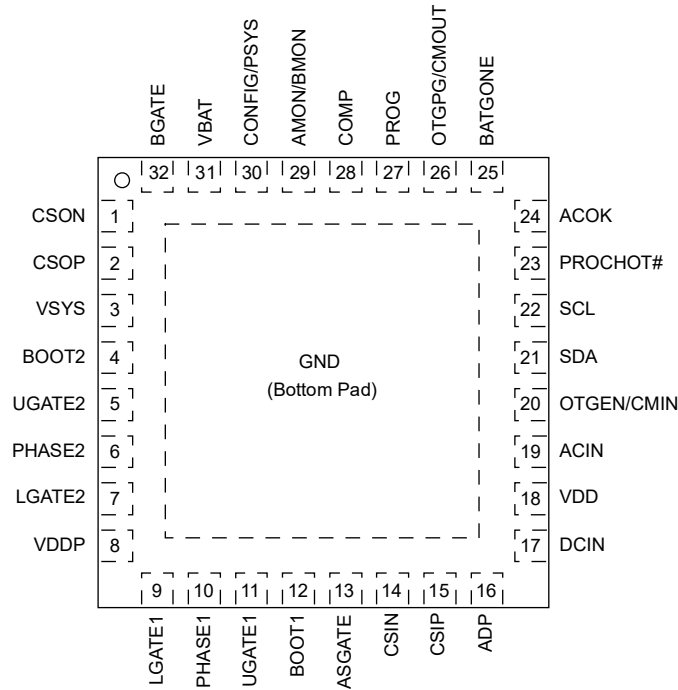

Figure 5. Pin Assignments – Top View

2.2 Pin Descriptions

Pin Number	Pin Name	Description
Bottom Pad	GND	Signal common to the IC. Unless otherwise stated, signals are referenced to the GND pin. GND should also be used as the thermal pad for heat dissipation.
1	CSON	Battery current sense negative input. Connect to the battery current resistor negative input. Place a ceramic capacitor between CSOP and CSON to provide differential mode filtering.
2	CSOP	Battery current sense positive input. Connect to the battery current resistor positive input. Place a ceramic capacitor between CSOP and CSON to provide differential mode filtering.
3	VSYS	Provides feedback voltage for MaxSystemVoltage regulation.
4	BOOT2	High-side MOSFET Q4 gate driver supply. Connect an MLCC capacitor across the BOOT2 and PHASE2 pins. The boot capacitor is charged through an internal boot diode connected from the VDDP to BOOT2 pins. Connect a 0.47µF bootstrap capacitor, which must have an effective capacitance higher than 0.25µF at 5V and x50 effective high-side MOSFET gate capacitance.
5	UGATE2	High-side MOSFET Q4 gate drive.
6	PHASE2	Current return path for the high-side MOSFET Q4 gate drive. Connect this pin to the node consisting of the high-side MOSFET Q4 source, the low-side MOSFET Q3 drain, and one terminal of the inductor.
7	LGATE2	Low-side MOSFET Q3 gate drive.
8	VDDP	Power supply for the gate drivers. Connect to the VDD pin through a 4.7Ω resistor and connect a 2.2µF (10V) MLCC capacitor to GND. The capacitor must have an effective capacitance higher than 0.4µF at 5V and x1.6 effective capacitance at the BOOT pin at 5V.

Pin Number	Pin Name	Description
9	LGATE1	Low-side MOSFET Q2 gate drive.
10	PHASE1	Current return path for the high-side MOSFET Q1 gate drive. Connect this pin to the node consisting of the high-side MOSFET Q1 source, the low-side MOSFET Q2 drain, and one terminal of the inductor.
11	UGATE1	High-side MOSFET Q1 gate drive.
12	BOOT1	High-side MOSFET Q1 gate driver supply. Connect an MLCC capacitor across the BOOT1 and PHASE1 pins. The boot capacitor is charged through an internal boot diode connected from the VDDP to BOOT1 pins. Connect a 0.47 μ F bootstrap capacitor, which must have an effective capacitance higher than 0.25 μ F at 5V and x50 effective high-side MOSFET gate capacitance.
13	ASGATE	Gate drive output to the P-channel adapter FET. The use of ASGATE FETs is optional. If they are not used, leave the ASGATE pin floating.
14	CSIN	Adapter current sense negative input.
15	CSIP	Adapter current sense positive input. The modulator also uses the CSIP pin for sensing input voltage in forward mode and output voltage in reverse mode.
16	ADP	Adapter input used to sense adapter voltage. ASGATE is turned on when the adapter voltage is higher than 3.2V. The ADP pin also provides one of the two internal low power LDO inputs.
17	DCIN	Internal LDO input that provides power to the IC. Connect a diode OR from the adapter and system outputs. Bypass DCIN with an MLCC capacitor. Connect a 10 Ω DCIN resistor between the DCIN pin and the VADP/VSYS diodes, and connect a 4.7 μ F DCIN capacitor to GND. The capacitor must have an effective capacitance higher than 0.4 μ F at 30V.
18	VDD	Internal LDO output that provides the bias power for the internal analog and digital circuit. Connect a 2.2 μ F (10V) MLCC capacitor to GND. The capacitor must have an effective capacitance higher than 0.4 μ F at 5V and x1.6 effective capacitance at the BOOT pin at 5V. If VDD is pulled below 2V for more than 1ms, the RAA489118 resets all the SMBus register values to their defaults.
19	ACIN	Adapter voltage sense. Use a resistor divider externally to detect adapter voltage. The adapter voltage is valid if the ACIN pin voltage is greater than 0.6V.
20	OTGEN/ CMIN	Input pin. OTG function enable pin, stand-alone comparator input pin. When the OTG function is enabled and the general purpose comparator is disabled, pulling this pin high can activate the OTG function. When the general purpose comparator is enabled, this pin is the general purpose comparator input.
21	SDA	SMBus data I/O. Connect to the data line from the host controller or smart battery. Connect a 10k pull-up resistor according to the SMBus specification.
22	SCL	SMBus clock I/O. Connect to the clock line from the host controller or smart battery. Connect a 10k pull-up resistor according to the SMBus specification.
23	PROCHOT#	Open-drain output. Pulled low when ACHOT, DCHOT, or Low_VSYS are detected. IMVP compliant. Send an SMBus command to pull low with OTGCURRENT, BATGONE, ACOK, and the general purpose comparator (see Table 7).
24	ACOK	Adapter presence indicator output to indicate the adapter is ready.
25	BATGONE	Input pin to the IC. Logic high on this pin indicates the battery has been removed. Logic low on this pin indicates the battery is present. BATGONE pin logic high forces the BGATE FET to turn off in any circumstances.
26	OTGPG/ CMOUT	Open-drain output. OTG function output power-good indicator or the stand-alone comparator output. When the OTG function is enabled, this signal is low if the OTG output voltage is not within the regulation window. When the OTG function is not used, this signal is the general purpose comparator output. GP comparator must be disabled for OTGPG to function as expected.

Pin Number	Pin Name	Description
27	PROG	A resistor from the PROG pin to GND sets the following configurations: <ul style="list-style-type: none"> ▪ Default number of the battery cells in series: 2 to 7 cells ▪ Autonomous Charging mode: Enabled or disabled See Table 16 for programming options.
28	COMP	Error amplifier output. Connect a compensation network externally from COMP to GND.
29	AMON/ BMON	Adapter current, OTG output current, battery charging current, or battery discharging current monitor output. <ul style="list-style-type: none"> ▪ $V_{AMON} = 18x (V_{CSIP} - V_{CSIN})$ for adapter current monitor ▪ $V_{OTGCMON} = 18x (V_{CSIN} - V_{CSIP})$ for OTG output current monitor ▪ $V_{BMON_DISCHARGING} = 18x (V_{CSON} - V_{CSOP})$ for battery discharging current monitor ▪ $V_{BMON_CHARGING} = 36x (V_{CSOP} - V_{CSON})$ for battery charging current monitor
30	CONFIG/ PSYS	CONFIG/PSYS is tied to VDD for Buck-Boost charger configuration without BFET. CONFIG/PSYS is connected to the PSYS resistor for PSYS function for Buck-Boost charger configuration with BFET. Current source output that indicates the platform power consumption. PSYS gain = 0.236 μ A/W (default) or 0.118 μ A/W
31	VBAT	Battery voltage sensor. Used for trickle charging detection and Ideal Diode mode control. Connect an optional ceramic capacitor >1 μ F from VBAT to GND. The VBAT pin is also one of the two internal low power LDO inputs.
32	BGATE	Gate drive output to the P-channel FET connecting the system and the battery. This pin can go high to disconnect the battery, low to connect the battery, or operate in Linear mode to maintain the system voltage at the MinSystemVoltage level during trickle charging.

3. Specifications

3.1 Absolute Maximum Ratings

Caution: Do not operate at or near the maximum ratings listed for extended periods of time. Exposure to such conditions can adversely impact product reliability and result in failures not covered by warranty.

Parameter	Minimum	Maximum	Unit
CSIP, CSIN, DCIN, ADP, ASGATE	-0.3	+36	V
DCIN - VDD	-0.3	+31	V
PHASE1	GND - 0.3	+36	V
PHASE1	GND - 2 (<20ns)	+36	V
BOOT1, UGATE1	GND - 0.3	VDDP+36	V
PHASE2	GND - 0.3	36	V
PHASE2	GND - 2 (<20ns)	36	V
BOOT2, UGATE2	GND - 0.3	VDDP+36	V
LGATE1, LGATE2	GND - 0.3	+6.5	V
LGATE1, LGATE2	GND - 2 (<20ns)	+6.5	V
VBAT, VSYS, CSOP, CSON, BGATE	-0.3	+36	V
VDD, VDDP	-0.3	+6.5	V
COMP	-0.3	+6.5	V
AMON/BMON, PSYS	-0.3	+6.5	V
OTGEN, BATGONE	-0.3	+6.5	V
ACIN, PROCHOT#, OTGPG, ACOK	-0.3	+6.5	V
SCL, SDA	-0.3	+6.5	V
BOOT1 - PHASE1, BOOT2 - PHASE2	-0.3	+6.5	V
CSIP - CSIN, CSOP - CSON	-0.3	+0.3	V
OTGPG, PROCHOT#, ACOK	-	2	mA
Junction Temperature Range (T _J)	-10	+125	°C
Storage Temperature Range (T _S)	-65	+175	°C
Human Body Model (Tested per JS-001-2023)	-	2	kV
Charged Device Model (Tested per JS-002-2022)	-	750	V
Latch-Up (Tested per JESD78E; Class 2, Level A)	-	100	mA

3.2 Recommended Operating Conditions

Parameter	Minimum	Maximum	Unit	
Ambient Temperature	RAA489118ARGNP	-10	+100	°C
	RAA489118A3GNP	-40	+100	°C
Junction Temperature	RAA489118ARGNP	-10	+125	°C
	RAA489118A3GNP	-40	+125	°C
Adapter Voltage	+4	+30	V	

3.3 Thermal Specifications

Parameter	Package	Symbol	Conditions	Typical Value	Unit
Thermal Resistance	32 Ld TQFN Package	$\theta_{JA}^{[1]}$	Junction to ambient.	38	°C/W
		$\theta_{JC}^{[2]}$	Junction to case.	2.5	°C/W

- θ_{JA} is measured in free air with the component mounted on a high-effective thermal conductivity test board with direct attach features. See [TB379](#).
- For θ_{JC} , the case temperature location is the center of the exposed metal pad on the package underside.

3.4 Electrical Specifications

Operating conditions: ADP = CSIP = CSIN = 5V and 28V, VSYS = VBAT = CSOP = CSON = 8V and 29.4, unless otherwise noted. **Boldface limits apply across the junction temperature range, -40°C to +125°C unless otherwise specified.**

Parameter	Symbol	Test Conditions	Min ^[1]	Typ	Max ^[1]	Unit
UVLO/ACOK						
VADP UVLO Rising	VADP_UVLO_r	-	3.05	3.4	3.7	V
VADP UVLO Hysteresis ^[2]	VADP_UVLO_h	-	-	600	-	mV
VBAT UVLO Rising	VBAT_UVLO_r	-	2.30	2.45	2.65	V
VBAT UVLO Hysteresis	VBAT_UVLO_h	-	-	400	-	mV
VBAT 4P5V Rising	VBAT_4P5_r	-	4.25	4.50	4.90	V
VBAT 4P5V Hysteresis	VBAT_4P5_h	-	-	400	-	mV
VDD 2P7 POR Falling, SMBus and BGATE/BMON Active Threshold	VDD_2P7_f	-	2.5	2.7	2.9	V
VDD 2P7 POR Hysteresis ^[2]	VDD_2P7_h	-	-	150	-	mV
VDD 3P8 POR Rising, Modulator and Gate Driver Active	VDD_3P8_r	-	3.6	3.8	3.9	V
VDD 3P8 POR Hysteresis	VDD_3P8_h	-	-	140	-	mV
ACIN Rising	ACIN_r	-	0.58	0.6	0.615	V
ACIN Hysteresis	ACIN_h	-	-	50	-	mV
Linear Regulator						
VDD Output Voltage	VDD	$6V < V_{DCIN} < 30V$	4.5	5.0	5.5	V
VDD Dropout Voltage	VDD_dp	$<35mA, V_{DCIN} = 4V$	-	-	200	mV
VDD Overcurrent Threshold	VDD_OC	ARGNP Junction Temperature: -10 to +125°C	85	115	145	mA
		A3GNP Junction Temperature: -40 to +125°C	85	115	155	

Operating conditions: ADP = CSIP = CSIN = 5V and 28V, VSYS = VBAT = CSOP = CSON = 8V and 29.4, unless otherwise noted.
Boldface limits apply across the junction temperature range, -40°C to +125°C unless otherwise specified. (Cont.)

Parameter	Symbol	Test Conditions	Min ^[1]	Typ	Max ^[1]	Unit
Battery Current	I _{BAT1}	Battery only, BGATE OFF, PSYS OFF, GPC OFF, BMON OFF, V _{BAT} = 29.4V, DCIN current comes from battery, I _{BAT} = I _{VBAT} + I _{CSOP} + I _{CSON} + I _{DCIN} + I _{VSYS}	-	24	50	μA
	I _{BAT2}	Battery only, BGATE ON, PSYS OFF, GPC OFF, BMON ON, V _{BAT} = 29.4V, DCIN current comes from battery, I _{BAT} = I _{VBAT} + I _{CSOP} + I _{CSON} + I _{DCIN} + I _{VSYS}	-	74	-	
	I _{BAT3}	Battery only, BGATE on, PSYS ON, BMON OFF, V _{BAT} = 29.4V, DCIN current comes from battery, I _{BAT} = I _{VBAT} + I _{CSOP} + I _{CSON} + I _{DCIN} + I _{VSYS}	-	925	1155	
Adapter Current Regulation, R_{s1} = 10mΩ						
Adapter Current Accuracy	-	CSIP - CSIN = 50mV	-	5	-	A
			-2.2	-	2.2	%
		CSIP - CSIN = 40mV	-	4	-	A
			-2.5	-	2.5	%
		CSIP - CSIN = 30mV	-	3	-	A
			-3.5	-	3.5	%
		CSIP - CSIN = 25mV	-	2.5	-	A
			-4.2	-	4.2	%
		CSIP - CSIN = 20mV	-	2	-	A
			-5.0	-	5.0	%
CSIP - CSIN = 15mV	-	1.5	-	A		
	-6.9	-	6.9	%		
CSIP - CSIN = 10mV	-	1	-	A		
	-10	-	10	%		
CSIP - CSIN = 5mV	-	0.5	-	A		
	-20	-	20	%		
CSIP - CSIN = 2.5mV	-	0.25	-	A		
	-40	-	40	%		
Adapter Current PROCHOT# Threshold R _{s1} = 10mΩ	I _{ADP_HOT_TH10}	ACProchot = 0x0B00H (5.632A)	-	5.632	-	A
			-1.5	-	1.5	%
		ACProchot = 0x0500H (2.56A)	-	2.56	-	A
			-2.5	-	2.5	%
		ACProchot = 0x0400H (2.048A)	-	2.048	-	A
			-4	-	4	%
ACProchot = 0x0200H (1.024A)	-	1.024	-	A		
	-6	-	6	%		

Operating conditions: ADP = CSIP = CSIN = 5V and 28V, VSYS = VBAT = CSOP = CSON = 8V and 29.4, unless otherwise noted.
Boldface limits apply across the junction temperature range, -40°C to +125°C unless otherwise specified. (Cont.)

Parameter	Symbol	Test Conditions	Min ^[1]	Typ	Max ^[1]	Unit
System Voltage Regulation						
Maximum System Voltage Accuracy	-	MaxSystemVoltage for 8.4V and 12.6V	-1.0	-	1.0	%
		MaxSystemVoltage for 16.8V and 21V	-0.75	-	0.75	
		MaxSystemVoltage for 25.2V and 29.4V	-0.5	-	0.5	
Minimum System Voltage Accuracy	-	VDAC = 5V to 25V	-3	-	3	%
Input Voltage Regulation Accuracy	-	Input Voltage Register = 4.096V	3.92	-	4.18	V
Charge Current Regulation, R_{s2} = 5mΩ (Limits apply across temperature range of 0°C to +85°C)						
Charge Current Accuracy	-	V _{CSOP} - V _{CSON} = 30mV	-	6	-	A
			-3.5	-	3.5	%
		V _{CSOP} - V _{CSON} = 25mV	-	5	-	A
			-3.85	-	3.85	%
		V _{CSOP} - V _{CSON} = 20mV	-	4	-	A
			-4	-	4	%
		V _{CSOP} - V _{CSON} = 15mV	-	3	-	A
			-5.2	-	5.2	%
		V _{CSOP} - V _{CSON} = 10mV	-	2	-	A
			-6	-	6	%
		V _{CSOP} - V _{CSON} = 5mV	-	1	-	A
			-12	-	12	%
V _{CSOP} - V _{CSON} = 2.5mV	-	0.5	-	A		
	-22.2	-	22.2	%		
V _{CSOP} - V _{CSON} = 1.28mV	-	0.256	-	A		
	-42	-	42	%		
BGATE Clamp						
VSYS - VBGATE ON	-	Charging enabled	7.45	8.30	9.05	V
VSYS - VBGATE OFF	-	Charging disabled	-	0	-	V
ASGATE Clamp						
VADP - VASGATE ON	-		-	10	-	V
VADP - VASGATE OFF	-		-	0	-	V
Trickle Charging Current Regulation, R_{s2} = 5mΩ (Limits apply across temperature range of 0°C to +85°C)						
Trickle Charge Current Accuracy	-	Trickle, 1024mA	938	1024	1109	mA
		Trickle, 512mA	410	512	614	
		Trickle, 256mA	180	256	360	
		Trickle, 128mA	55	128	192	
Fast Charge to Trickle Charge Threshold	-	V _{VSYS} - V _{BGATE}	4.5	5.05	5.6	V

Operating conditions: ADP = CSIP = CSIN = 5V and 28V, VSYS = VBAT = CSOP = CSON = 8V and 29.4, unless otherwise noted.
Boldface limits apply across the junction temperature range, -40°C to +125°C unless otherwise specified. (Cont.)

Parameter	Symbol	Test Conditions	Min ^[1]	Typ	Max ^[1]	Unit
Trickle Charge to Fast Charge Threshold Hysteresis	-	$V_{SYS} - V_{BGATE}$	50	130	290	mV
Fast Charge to Trickle Charge BGATE Threshold ^[2]	-	$V_{SYS} > 7V, V_{FB} \gg V_{REF}$	-	1.15	-	V
Trickle Charge to Fast Charge BGATE Threshold Hysteresis ^[2]	-	$V_{SYS} > 7V, V_{FB} \gg V_{REF}$	-	50	-	mV
Ideal Diode Mode						
Entering Ideal Diode Mode VSYS Voltage Threshold	-	BGATE off, VSYS falling $V_{BAT} - V_{CSON}$	100	150	200	mV
Exiting Ideal Diode Mode Battery Discharging Current Threshold	-	$R_{s2} = 5m\Omega$	190	380	550	mA
Exiting Ideal Diode Mode Battery Charging Current Threshold	-	$R_{s2} = 5m\Omega$	150	250	350	mA
BGATE Source	-	$V_{SYS} - V_{BGATE} = 2V$, charging disabled	4	5	10	mA
BGATE Sink	-	$V_{BGATE} - V_{GND} = 2V$, charging enabled	20	30	40	μA
BGATE Sink	-	$V_{BGATE} - V_{GND} = 2V$, in Ideal Diode mode	-	9	-	mA
AMON/BMON						
Input Current Sense Amplifier, $R_{s1} = 10m\Omega$						
CSIP/CSIN Input Voltage Range ^[2]	-	-	4	-	30	V
Forward AMON Gain	-	-	-	18.01	-	V/V
Forward AMON Accuracy $V_{AMON} = 18.01 \times (V_{CSIP} - V_{CSIN})$	-	$V_{CSIP} - V_{CSIN} = 50mV$ (5A), $V_{CSIP} = 5V, 28V$	-2.8	-	2.8	%
		$V_{CSIP} - V_{CSIN} = 10mV$ (1A), $V_{CSIP} = 5V, 28V$	-10	-	10	
		$V_{CSIP} - V_{CSIN} = 5mV$ (0.5A), $V_{CSIP} = 5V, 28V$	-16.8	-	16.8	
		$V_{CSIP} - V_{CSIN} = 1mV$ (0.1A), $V_{CSIP} = 5V, 28V$	-78.8	-	78.8	
Reverse AMON Gain	-	-	-	17.9	-	V/V
Reverse AMON Accuracy $V_{AMON} = 17.9 \times (V_{CSIP} - V_{CSIN})$	-	$V_{CSIN} - V_{CSIP} = 40mV$ (4A), $V_{CSIP} = 5V, 28V$	-4.5	-	4.5	%
		$V_{CSIN} - V_{CSIP} = 10mV$ (1A), $V_{CSIP} = 5V, 28V$	-12.6	-	13.5	
		$V_{CSIN} - V_{CSIP} = 5mV$ (0.5A), $V_{CSIP} = 5V, 28V$	-25.5	-	25.5	
		$V_{CSIN} - V_{CSIP} = 2.56mV$ (0.256A), $V_{CSIP} = 5V, 28V$	-48.5	-	48.5	

Operating conditions: ADP = CSIP = CSIN = 5V and 28V, VSYS = VBAT = CSOP = CSON = 8V and 29.4, unless otherwise noted.
Boldface limits apply across the junction temperature range, -40°C to +125°C unless otherwise specified. (Cont.)

Parameter	Symbol	Test Conditions	Min ^[1]	Typ	Max ^[1]	Unit
AMON Minimum Output Voltage	-	$V_{CSIP} - V_{CSIN} = 0V$	-	-	30	mV
Discharge Current Sense Amplifier, $R_{S2} = 5m\Omega$						
BMON Gain (Battery Discharging)	-	-	-	17.97	-	V/V
BMON Accuracy $V_{BMON} = 17.97 \times (V_{CSON} - V_{CSOP})$	-	$V_{CSON} - V_{CSOP} = 50mV (10A),$ $V_{CSON} = 8V, 29.4V$	-3.5	-	3.1	%
		$V_{CSON} - V_{CSOP} = 10mV (2A),$ $V_{CSON} = 8V, 29.4V$	-11.5	-	6	
		$V_{CSON} - V_{CSOP} = 5mV (1A),$ $V_{CSON} = 8V, 29.4V$	-23	-	14	
		$V_{CSON} - V_{CSOP} = 3mV (0.6A),$ $V_{CSON} = 8V, 29.4V$	-39	-	22.1	
Charge Current Sense Amplifier, $R_{S2} = 5m\Omega$ (Limits apply across the temperature range of 0°C to +85°C)						
BMON Gain (Battery Charging)	-	-	-	36.07	-	V/V
BMON Accuracy $V_{BMON} = 36.07 \times (V_{CSOP} - V_{CSON})$	-	$V_{CSOP} - V_{CSON} = 30mV (6A),$ $V_{CSON} = 8V, 29.4V$	-5	-	5	%
		$V_{CSOP} - V_{CSON} = 20mV (4A),$ $V_{CSON} = 8V, 29.4V$	-5.9	-	5.9	
		$V_{CSOP} - V_{CSON} = 5mV (1A),$ $V_{CSON} = 8V, 29.4V$	-13.9	-	13.9	
		$V_{CSOP} - V_{CSON} = 2.5mV (0.5A),$ $V_{CSON} = 8V, 29.4V$	-24.6	-	24.6	
		$V_{CSOP} - V_{CSON} = 1.28mV (0.256A),$ $V_{CSON} = 8V, 29.4V$	-45	-	45	
BMON Minimum Output Voltage	-	$V_{CSOP} - V_{CSON} = 0V$	-	-	31	mV
Discharging Current PROCHOT# Threshold, $R_{S2} = 5m\Omega$	$I_{DIS_HOT_TH}$	DCProchot# = 2.048A	1.77	2.08	2.39	A
Discharging Current PROCHOT# Threshold, Battery Only, $R_{S2} = 5m\Omega$	$I_{DIS_HOT_TH}$	DCProchot# = 12A	10.6	12.9	15.2	A
		DCProchot# = 6A	5.2	6.5	8	A
AMON/BMON Source Resistance ^[2]	-	-	-	-	5	Ω
AMON/BMON Sink Resistance ^[2]	-	-	-	-	5	Ω
BATGONE and OTGEN						
High-Level Input Voltage	-	-	0.9	-	-	V
Low-Level Input Voltage	-	-	-	-	0.4	V
Pull-Down Current	-	BATGONE and OTGEN = 5V	-	5	-	μA

Operating conditions: ADP = CSIP = CSIN = 5V and 28V, V_{SY}S = V_{BAT} = CSOP = CSON = 8V and 29.4, unless otherwise noted.
Boldface limits apply across the junction temperature range, -40°C to +125°C unless otherwise specified. (Cont.)

Parameter	Symbol	Test Conditions	Min ^[1]	Typ	Max ^[1]	Unit
PROCHOT#						
PROCHOT# Debounce Time	-	Control2 register Bit[10:9] = 11	0.85	1	1.15	ms
		Control2 register Bit[10:9] = 10	425	500	575	μs
PROCHOT# Duration Time	-	Control2 register Bit[8:6] = 000	8.5	10	11.5	ms
		Control2 register Bit[8:6] = 001	17	20	23	
Low V _{SY} S PROCHOT# Trip Threshold	V _{LOW_VSY} S_HOT	Control1 register Bit[1:0] = 00	5.8	6.0	6.2	V
		Control1 register Bit[1:0] = 01	6.1	6.3	6.5	
		Control1 register Bit[1:0] = 10	6.4	6.6	6.8	
		Control1 register Bit[1:0] = 11	6.7	6.9	7.1	
PSYS with NVDC Charger Configuration when CONFIG/PSYS Is Not Tied High^[2]						
PSYS Output Current R _{s1} = 10mΩ R _{s2} = 5mΩ	I _{PSYS} Control3 Bit[9] = 0 I _{PSYS} = 0.236μA/W × Power + 0μA	V _{CSIP} = 28V, V _{CSIP} - V _{CSIN} = 40mV, V _{BAT} = 12V, 29.4V, V _{CSOP} - V _{CSON} = -10mV	-5	-	5	%
		V _{CSIP} = 28V, V _{CSIP} - V _{CSIN} = 80mV, V _{BAT} = 12V, 29.4V, V _{CSOP} - V _{CSON} = -20mV	-5	-	5	
Maximum PSYS Output Voltage	V _{PSYS_MAX}	-	3	-	-	V
Buck-Boost Charger Configuration without BFET when CONFIG/PSYS is Tied High						
Comparator at CONFIG/PSYS ^[2]	-	-	-	VDD-0.7V	-	V
OTG						
OTG Voltage	-	OTGVoltage register = 5.004V	4.9	5.03	5.15	V
OTG Current	-	OTGCurrent register = 512mA, (OTGVoltage = 5.004V, 29.4V)	373	512	675	mA
		OTGCurrent register = 1024mA, (OTGVoltage = 5.004V, 29.4V)	870	1024	1200	
		OTGCurrent register = 1536mA, (OTGVoltage = 5.004V, 29.4V)	1370	1536	1726	
		OTGCurrent register = 3072mA, (OTGVoltage = 5.004V, 29.4V)	2841	3072	3314	
		OTGCurrent register = 4096mA, (OTGVoltage = 5.004V, 29.4V)	3858	4096	4350	
General Purpose Comparator						
General Purpose Comparator Rising Threshold	-	Reference = 1.2V	1.11	1.2	1.32	V
		Reference = 2V	1.93	2	2.1	
General Purpose Comparator Hysteresis	-	Reference = 1.2V	-	45	-	mV
		Reference = 2V	-	45	-	

Operating conditions: ADP = CSIP = CSIN = 5V and 28V, VSYS = VBAT = CSOP = CSON = 8V and 29.4, unless otherwise noted.
Boldface limits apply across the junction temperature range, -40°C to +125°C unless otherwise specified. (Cont.)

Parameter	Symbol	Test Conditions	Min ^[1]	Typ	Max ^[1]	Unit
Protection						
VSYS Absolute Overvoltage Rising Threshold	-	-	32.2	33.6	34.3	V
VSYS Absolute Overvoltage Hysteresis ^[2]	-	-	-	540	-	mV
VSYS Overvoltage Rising Threshold	-	MaxSystemVoltage register value = 8.4V	9.68	10	10.27	V
		MaxSystemVoltage register value = 29.4V	30.6	31	31.6	V
VSYS Overvoltage Hysteresis	-	MaxSystemVoltage register value = 8.4V	550	790	1045	mV
		MaxSystemVoltage register value = 29.4V	600	850	1100	mV
VSYS UV Falling Threshold	-	Control6 register Bit[2:0] = 001	-	3	-	V
		Control6 register Bit[2:0] = 010	-	3.9	-	V
		Control6 register Bit[2:0] = 011	-	4.8	-	V
		Control6 register Bit[2:0] = 100	-	5.7	-	V
		Control6 register Bit[2:0] = 101	-	6.6	-	V
		Control6 register Bit[2:0] = 110	-	7.5	-	V
		Control6 register Bit[2:0] = 111	-	8.4	-	V
VSYS OK Threshold	-	-	0.45	0.6	0.75	V
VSYS OK Source Current	-	-	-	10	-	mA
Over-Temperature Threshold ^[2]	-	-	140	150	160	°C
Adapter Overvoltage Rising Threshold	-	-	32.2	33.3	33.95	V
Adapter Overvoltage Hysteresis	-	-	390	590	760	mV
OTG Undervoltage Falling Threshold	-	OTG voltage = 5.004V	2.85	3.2	3.65	V
OTG Undervoltage Rising Hysteresis ^[2]	-	OTG voltage = 5.004V	-	0.9	-	V
OTG Overvoltage Rising Threshold	-	OTG voltage = 5.004V	6.4	6.8	7.2	V
OTG Overvoltage Falling Hysteresis ^[2]	-	OTG voltage = 5.004V	-	0.9	-	V
Oscillator						
Oscillator Frequency, Digital Core Only	-	-	0.85	1	1.15	MHz
Digital Debounce Time Accuracy ^[2]	-	-	-15	-	15	%
Miscellaneous						
Switching Frequency Accuracy	-	COMP > 1.7V and not in period stretching	-15	-	15	%

Operating conditions: ADP = CSIP = CSIN = 5V and 28V, VSYS = VBAT = CSOP = CSON = 8V and 29.4, unless otherwise noted.
Boldface limits apply across the junction temperature range, -40°C to +125°C unless otherwise specified. (Cont.)

Parameter	Symbol	Test Conditions	Min ^[1]	Typ	Max ^[1]	Unit
Battery Learn Mode Auto-Exit Threshold	-	MinSystemVoltage = 5.376V Control1 register Bit[13] = 1	5.05	5.35	5.7	V
Battery Learn Mode Auto-Exit Hysteresis	-	MinSystemVoltage = 5.376V Control1 register Bit[13] = 1	-	330	-	mV
ADP Discharge Current	-	ADP = 5V to 32V	-	10	-	mA
VSYS Discharge Current	-	VSYS = 5V to 30.8V	-	10	-	mA
SMBus						
SDA/SCL Input Low Voltage	-	-	-	-	0.6	V
SDA/SCL Input High Voltage	-	-	1.3	-	-	V
SDA/SCL Input Bias Current	-	-	-	-	1	μA
SDA, Output Sink Current	-	SDA = 0.4V	4	-	-	mA
SMBus Frequency	f _{SMB}	-	10	-	400	kHz
Gate Driver^[2]						
UGATE1 Pull-Up Resistance	UG1 _{RPU}	100mA source current	-	800	1200	mΩ
UGATE1 Source Current	UG1 _{SRC}	UGATE1 - PHASE1 = 2.5V	1.3	2	-	A
UGATE1 Pull-Down Resistance	UG1 _{RPD}	100mA sink current	-	350	475	mΩ
UGATE1 Sink Current	UG1 _{SNK}	UGATE1 - PHASE1 = 2.5V	1.9	2.8	-	A
LGATE1 Pull-Up Resistance	LG1 _{RPU}	100mA source current	-	800	1200	mΩ
LGATE1 Source Current	LG1 _{SRC}	LGATE1 - GND = 2.5V	1.3	2	-	A
LGATE1 Pull-Down Resistance	LG1 _{RPD}	100mA sink current	-	300	450	mΩ
LGATE1 Sink Current	LG1 _{SNK}	LGATE1 - GND = 2.5V	2.3	3.5	-	A
LGATE2 Pull-Up Resistance	LG2 _{RPU}	100mA source current	-	800	1200	mΩ
LGATE2 Source Current	LG2 _{SRC}	LGATE2 - GND = 2.5V	1.3	2	-	A
LGATE2 Pull-Down Resistance	LG2 _{RPD}	100mA sink current	-	300	450	mΩ
LGATE2 Sink Current	LG2 _{SNK}	LGATE2 - GND = 2.5V	2.3	3.5	-	A
UGATE2 Pull-Up Resistance	UG2 _{RPU}	100mA source current	-	800	1200	mΩ
UGATE2 Source Current	UG2 _{SRC}	UGATE2 - PHASE2 = 2.5V	1.3	2	-	A
UGATE2 Pull-Down Resistance	UG2 _{RPD}	100mA sink current	-	350	475	mΩ
UGATE2 Sink Current	UG2 _{SNK}	UGATE2 - PHASE2 = 2.5V	1.9	2.8	-	A
UGATE1 to LGATE1 Dead Time	t _{UG1LG1DEAD}	-	10	20	40	ns

Operating conditions: ADP = CSIP = CSIN = 5V and 28V, VSYS = VBAT = CSOP = CSON = 8V and 29.4, unless otherwise noted. **Boldface limits apply across the junction temperature range, -40°C to +125°C unless otherwise specified.** (Cont.)

Parameter	Symbol	Test Conditions	Min ^[1]	Typ	Max ^[1]	Unit
LGATE1 to UGATE1 Dead Time	$t_{LG1UG1DEAD}$	-	10	20	40	ns
LGATE2 to UGATE2 Dead Time	$t_{LG2UG2DEAD}$	-	10	20	40	ns
UGATE2 to LGATE2 Dead Time	$t_{UG2LG2DEAD}$	-	10	20	40	ns

- Parameters with MIN and/or MAX limits are 100% tested at +25°C, unless otherwise specified. Temperature limits established by characterization and are not production tested.
- Values or limits established by characterization and are not production tested.

3.5 SMBus Timing Specification

Parameters	Symbol	Test Conditions	Min ^[1]	Typ	Max ^[1]	Unit
SMBus Frequency	F_{SMB}	-	10	-	400	kHz
Bus Free Time	t_{BUF}	-	4.7	-	-	μs
Start Condition Hold Time from SCL	$t_{HD:STA}$	-	4	-	-	μs
Start Condition Set-Up Time from SCL	$t_{SU:STA}$	-	4.7	-	-	μs
Stop Condition Set-Up Time from SCL	$t_{SU:STO}$	-	4	-	-	μs
SDA Hold Time from SCL	$t_{HD:DAT}$	-	300	-	-	ns
SDA Set-Up Time from SCL	$t_{SU:DAT}$	-	250	-	-	ns
SCL Low Period	t_{LOW}	-	4.7	-	-	μs
SCL High Period	t_{HIGH}	-	4	-	-	μs
SMBus Inactivity Timeout	-	Maximum charging period without a SMBus Write to MaxSystemVoltage or ChargeCurrent register	-	175	-	s

- Limits established by characterization and are not production tested.

3.6 Gate Driver Timing Diagrams

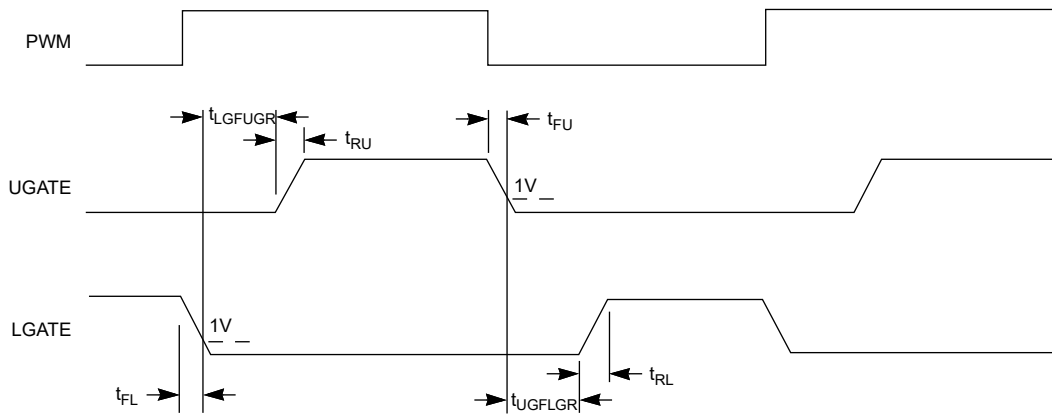

Figure 6. Gate Driver Timing Diagram

4. Typical Performance Graphs

4.1 Battery Charging Only (No BFET)

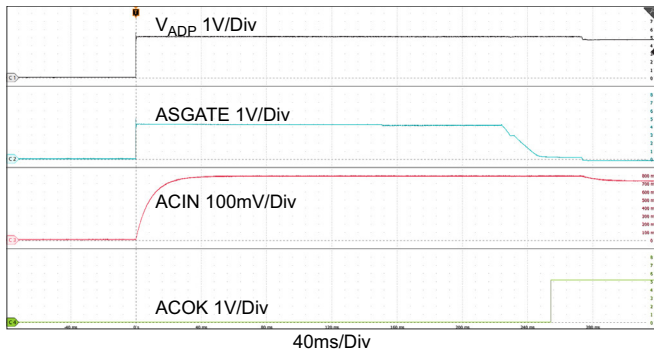

Figure 7. Adapter Insertion, V_{ADP} : 0V \rightarrow 5V,
 V_{BAT} = 18V, ChargeCurrent = 0.256A

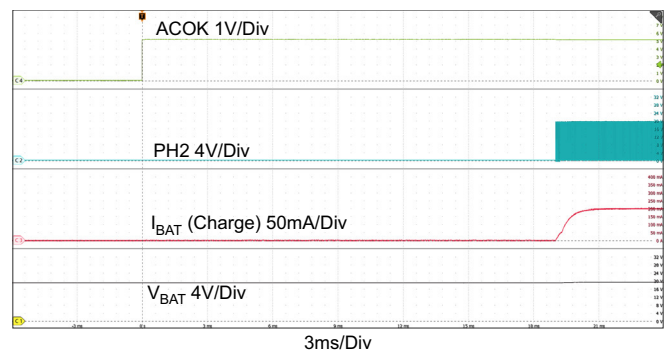

Figure 8. Adapter Insertion, V_{ADP} : 0V \rightarrow 5V,
 V_{BAT} = 18V, ChargeCurrent = 0.256A
(Figure 7 Zoomed In)

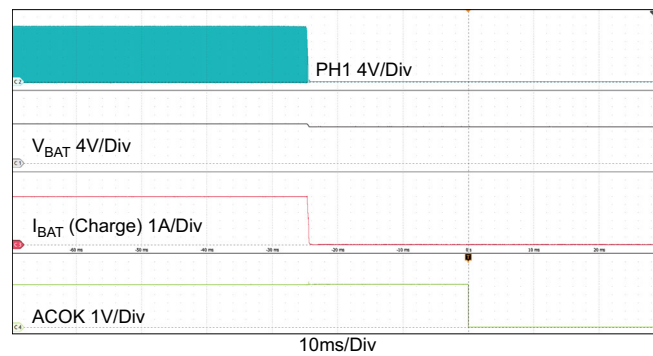

Figure 9. Adapter Removal, V_{ADP} : 28V \rightarrow 0V,
 V_{BAT} = 18V, ChargeCurrent = 6A

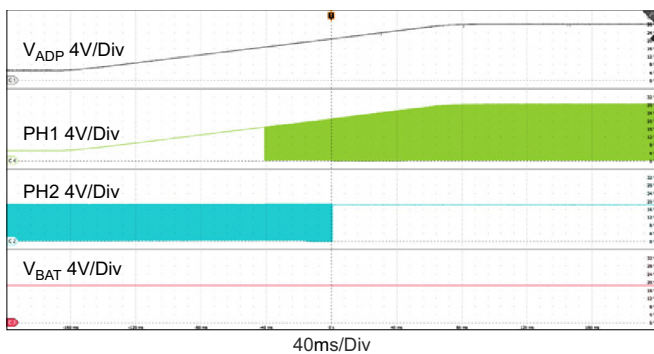

Figure 10. Adapter Voltage Ramp Up, Boost \rightarrow
Buck-Boost \rightarrow Buck Operation Mode Transitions

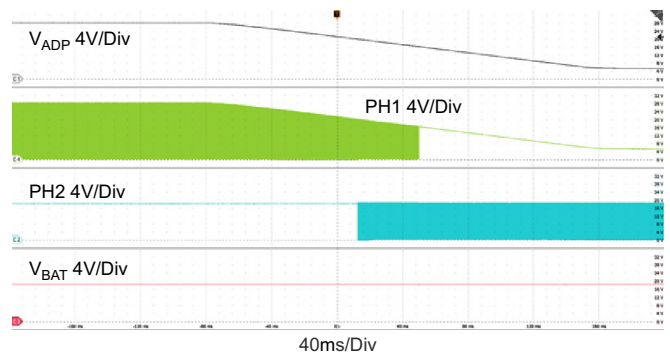

Figure 11. Adapter Voltage Ramp Down, Buck \rightarrow
Buck-Boost \rightarrow Boost Operation Mode Transitions

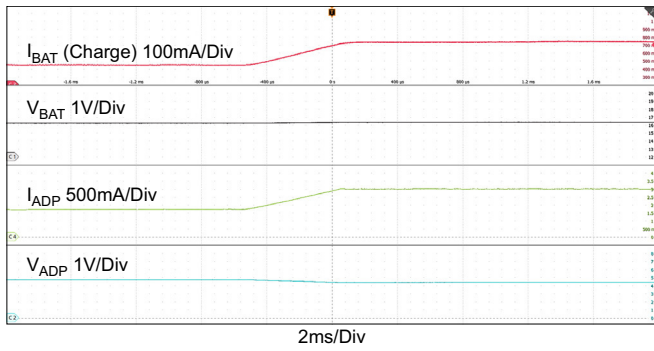

Figure 12. Boost Mode: Charge Current Loop to Adapter Current Loop, $V_{ADP} = 5V$, $V_{BAT} = 16V$, AdapterCurrentLimit = 3A, ChargeCurrent: 0.5A → 1A

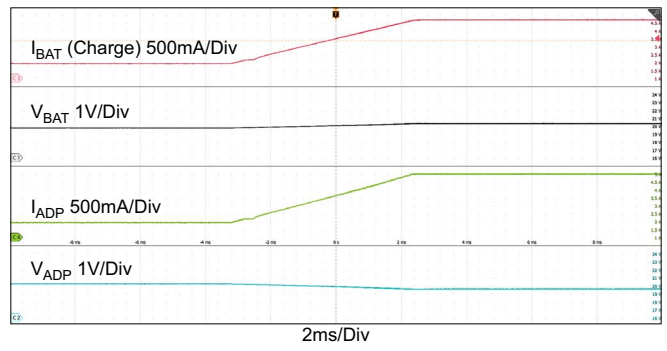

Figure 13. Buck_Boost Mode: Charge Current Loop to Adapter Current Loop, $V_{ADP} = 20V$, $V_{BAT} = 19V$, AdapterCurrentLimit = 5A, ChargeCurrent: 2A → 6A Buck_Boost_CCM_stretch_period = 2x

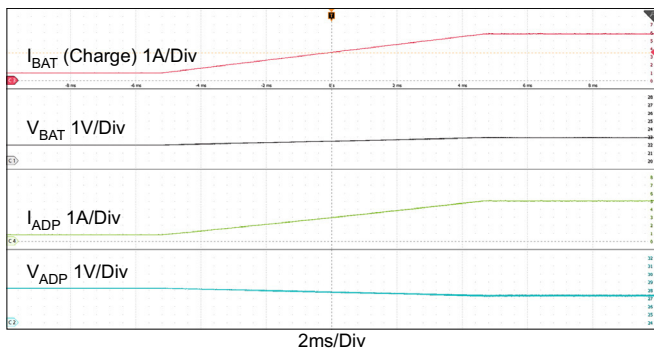

Figure 14. Buck Mode: Charge Current Loop to Adapter Current Loop, $V_{ADP} = 28V$, $V_{BAT} = 22V$, AdapterCurrentLimit = 5A, ChargeCurrent: 1A → 7A

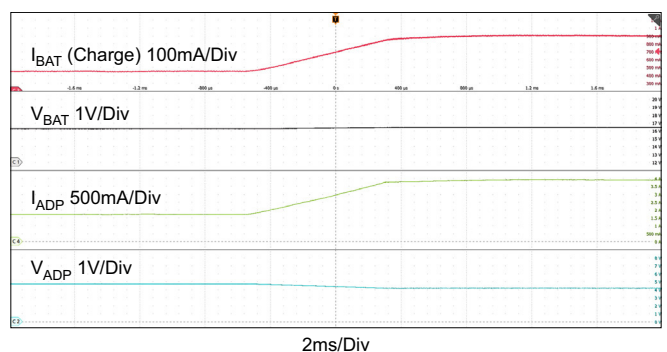

Figure 15. Boost Mode: Charge Current Loop to Input Voltage Loop, $V_{ADP} = 5V$, $V_{BAT} = 16V$, ChargeCurrent: 0.5A → 2A, InputVoltageLimit = 4.096V

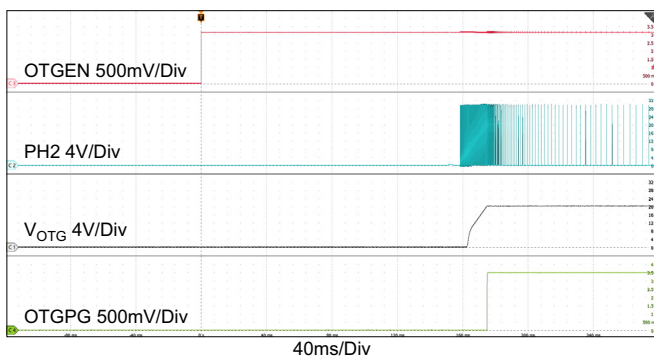

Figure 16. OTG Mode Enable, OTG_Debounce = 150ms, $V_{BAT} = 29.4V$, $V_{OTG} = 20V$

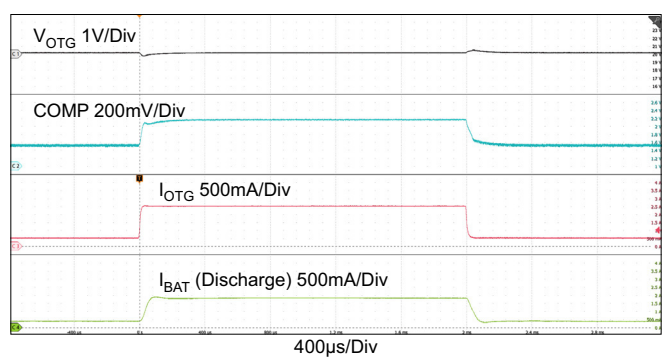

Figure 17. OTG Mode Transients, $V_{BAT} = 29.4V$, $V_{OTG} = 20V$, OTG Load: 0.5A ↔ 3A

4.2 NVDC Charging (with BFET)

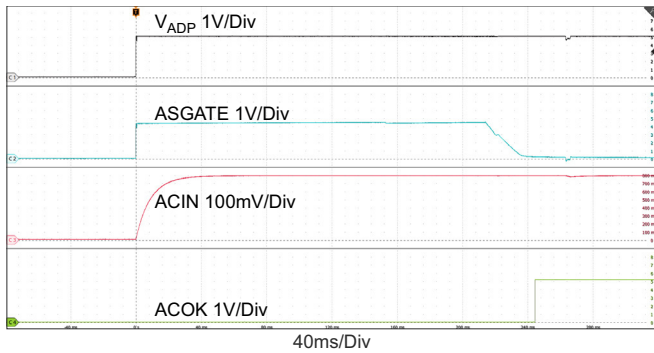

Figure 18. Adapter Insertion, V_{ADP} : 0V → 5V, V_{BAT} = 18V, ChargeCurrent = 0A

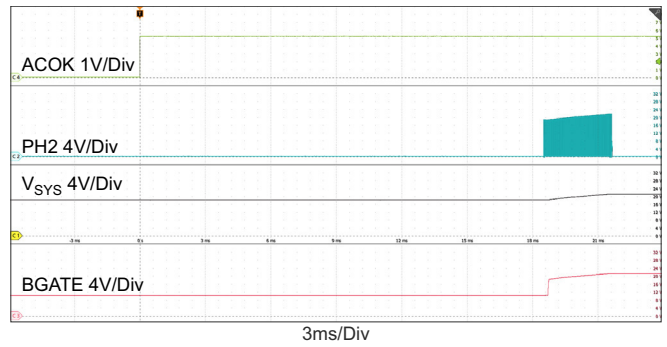

Figure 19. Adapter Insertion, V_{ADP} : 0V → 5V, V_{BAT} = 18V, ChargeCurrent = 0A
(Figure 18 Zoomed In)

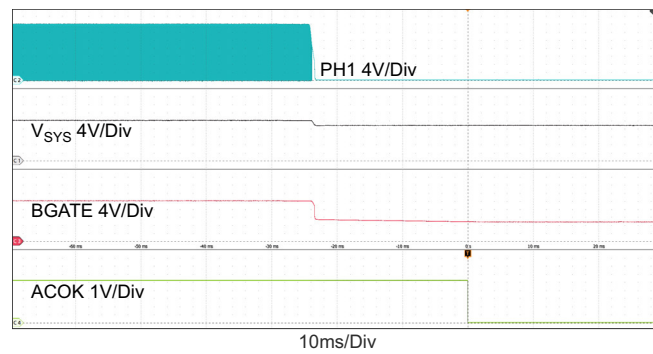

Figure 20. Adapter Removal, V_{ADP} : 28V → 0V, V_{BAT} = 18V, SystemLoad = 2A

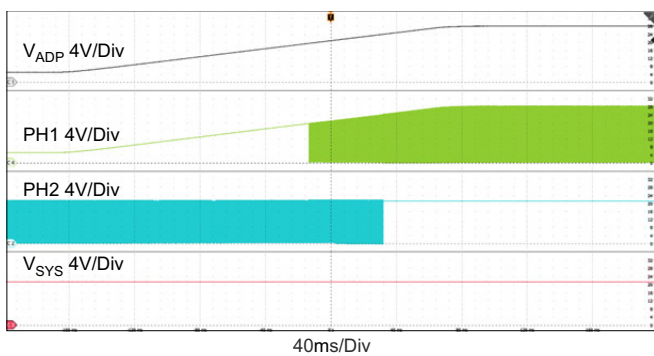

Figure 21. Adapter Voltage Ramp Up, Boost → Buck-Boost → Buck Operation Mode Transitions

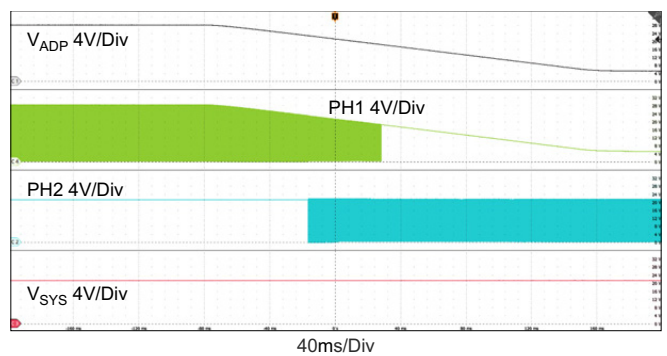

Figure 22. Adapter Voltage Ramp Down, Buck → Buck-Boost → Boost Operation Mode Transitions

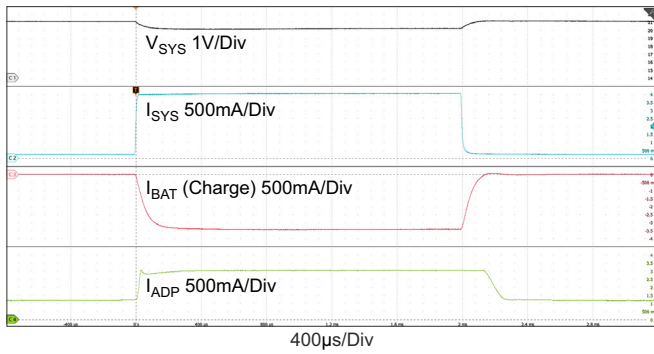

Figure 23. Boost Mode: Output Voltage Loop ↔ Adapter Current Loop, $V_{ADP} = 5V$, MaxSystemVoltage = 21V, $V_{BAT} = 20.5V$, AdapterCurrentLimit = 3A, ChargeCurrent = 0A, SystemLoad: 0.2A ↔ 4A

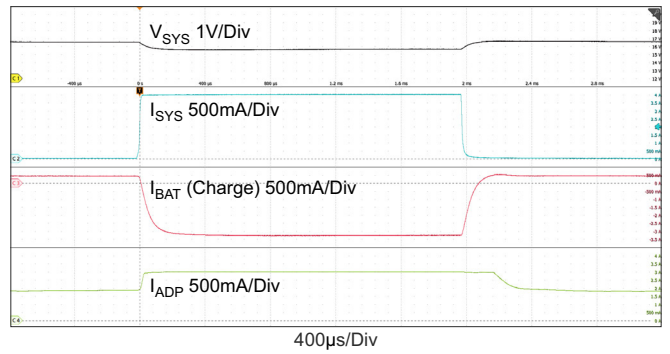

Figure 24. Boost Mode: Charge Current Loop ↔ Adapter Current Loop, $V_{ADP} = 5V$, MaxSystemVoltage = 21V, $V_{BAT} = 16V$, AdapterCurrentLimit = 3A, ChargeCurrent = 0.5A, SystemLoad: 0A ↔ 4A

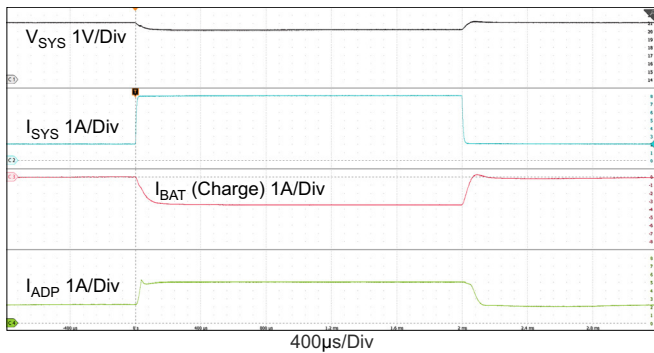

Figure 25. Buck-Boost Mode: Output Voltage Loop ↔ Adapter Current Loop, $V_{ADP} = 20V$, MaxSystemVoltage = 21V, $V_{BAT} = 20.5V$, AdapterCurrentLimit = 5A, ChargeCurrent = 0A, SystemLoad: 2A ↔ 8A, Buck_Boost_CCM_stretch_period = 2x

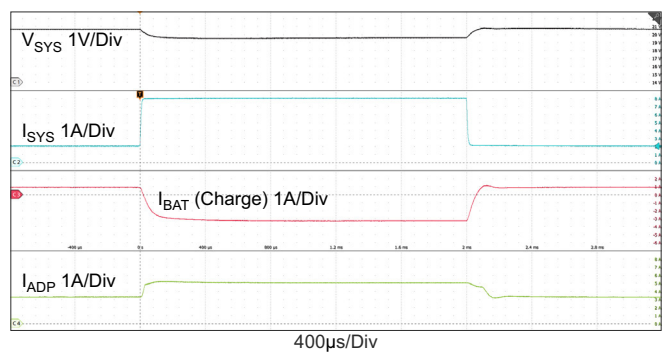

Figure 26. Buck-Boost Mode: Charge Current Loop ↔ Adapter Current Loop, $V_{ADP} = 20V$, MaxSystemVoltage = 21V, $V_{BAT} = 20V$, AdapterCurrentLimit = 5A, ChargeCurrent = 1A, SystemLoad: 2A ↔ 8A, Buck_Boost_CCM_stretch_period = 2x

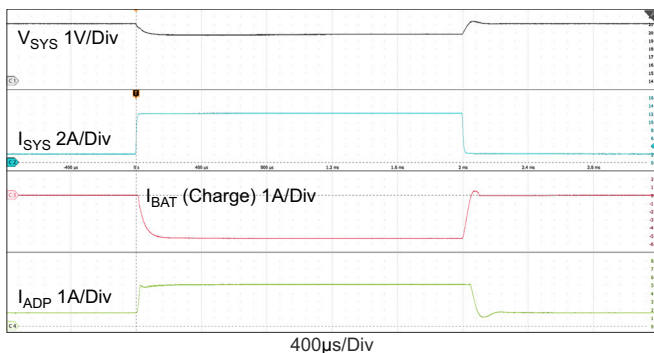

Figure 27. Buck Mode: Output Voltage Loop ↔ Adapter Current Loop, $V_{ADP} = 28V$, MaxSystemVoltage = 21V, $V_{BAT} = 20.5V$, AdapterCurrentLimit = 5A, ChargeCurrent = 0A, SystemLoad: 2A ↔ 12A

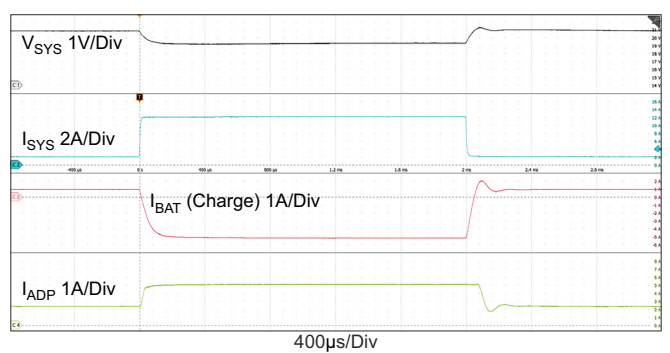

Figure 28. Buck Mode: Charge Current Loop ↔ Adapter Current Loop, $V_{ADP} = 28V$, MaxSystemVoltage = 21V, $V_{BAT} = 20V$, AdapterCurrentLimit = 5A, ChargeCurrent = 1A, SystemLoad: 2A ↔ 12A

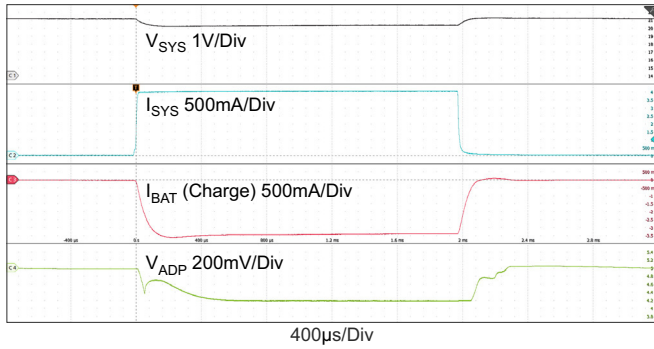

Figure 29. Boost Mode: Output Voltage Loop ↔ Input Voltage Loop, $V_{ADP} = 5V$, MaxSystemVoltage = 21V, $V_{BAT} = 20.5V$, InputVoltageLimit = 4.096V, ChargeCurrent = 0A, SystemLoad: 0A ↔ 4A

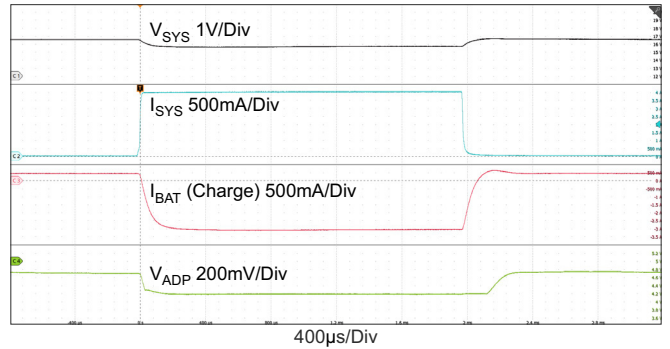

Figure 30. Boost Mode: Charge Current Loop ↔ Input Voltage Loop, $V_{ADP} = 5V$, MaxSysVoltage = 21V, $V_{BAT} = 16V$, InputVoltageLimit = 4.096V, ChargeCurrent = 0.5A, SystemLoad: 0A ↔ 4A

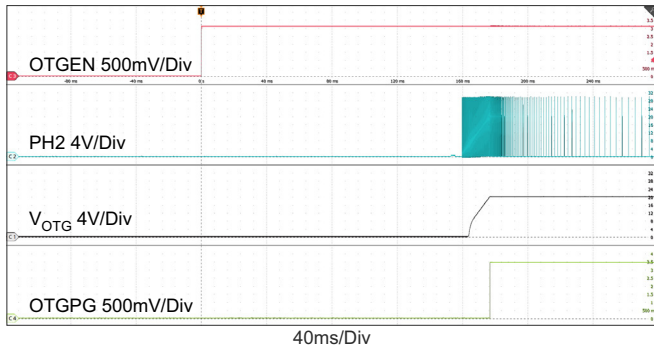

Figure 31. OTG Mode Enable. OTG_Debounce = 150ms, $V_{BAT} = 29.4V$, $V_{OTG} = 20V$

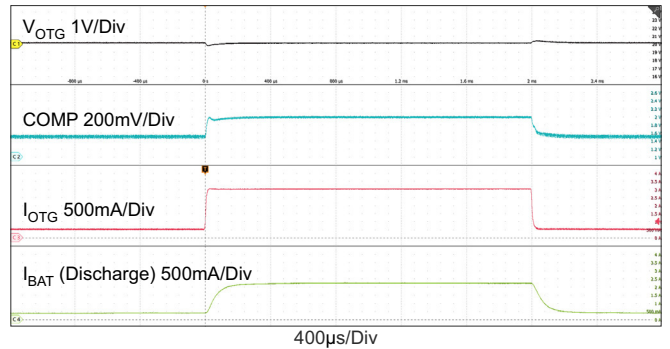

Figure 32. OTG Mode Transients. $V_{BAT} = 29.4V$, $V_{OTG} = 20V$, OTG Current = 5A, OTG Load: 0.5A ↔ 3A

5. General SMBus Architecture

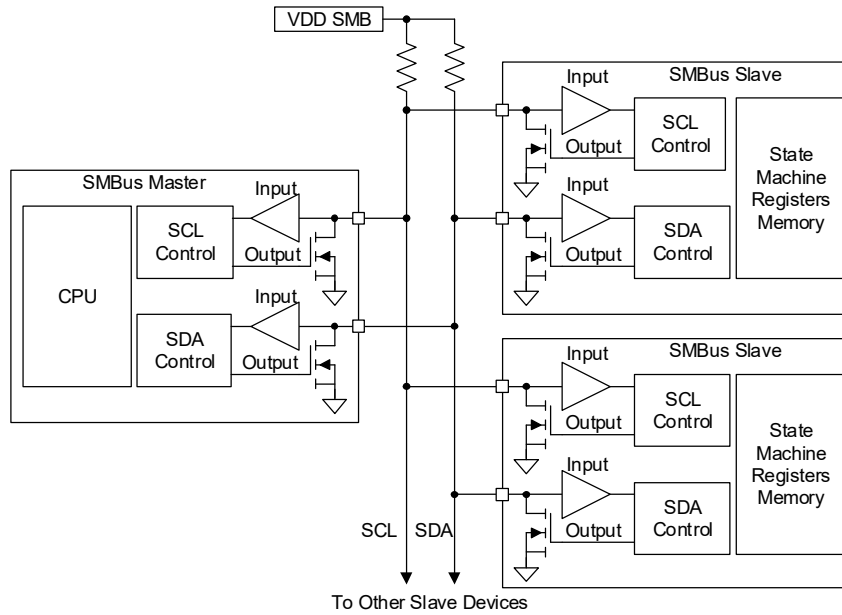

Figure 33. General SMBus

5.1 Data Validity

The data on the SDA line must be stable during the HIGH period of the SCL, unless generating a START or STOP condition. The HIGH or LOW state of the data line can change only when the clock signal on the SCL line is LOW. See Figure 34.

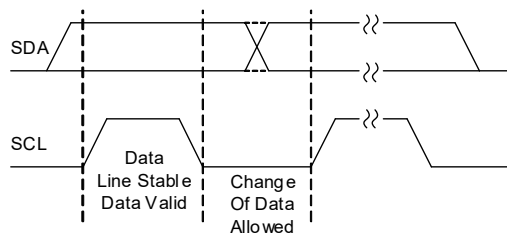

Figure 34. Data Validity

5.2 START and STOP Conditions

In Figure 35, the START condition is a HIGH to LOW transition of the SDA line while SCL is HIGH.

The STOP condition is a LOW to HIGH transition on the SDA line while SCL is HIGH. A STOP condition must be sent before each START condition.

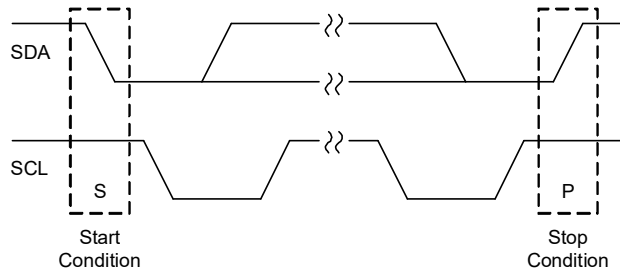

Figure 35. Start and Stop Waveforms

5.3 Acknowledge

Each address and data transmission uses nine clock pulses. The ninth pulse is the Acknowledge bit (ACK). After the start condition, the master sends seven slave address bits and a R/W bit during the next eight clock pulses. During the ninth clock pulse, the device that recognizes its own address holds the data line LOW to acknowledge (see Figure 36). Both the master and the slave use the ACK bit to acknowledge receipt of register addresses and data.

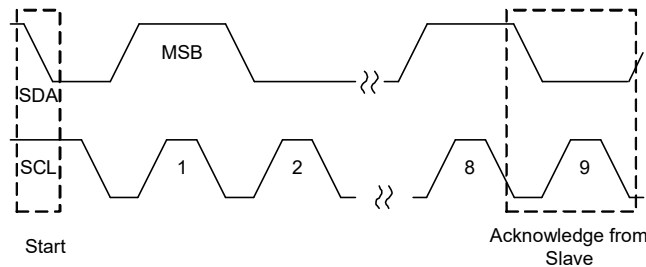

Figure 36. Acknowledge On The SMBus

5.4 SMBus Transactions

All transactions start with a control byte sent from the SMBus master device. The control byte begins with a Start condition followed by seven bits of slave address (0001001) and the R/W bit. The R/W bit is 0 for a WRITE or 1 for a READ. If any slave device on the SMBus bus recognizes its address, it acknowledges by pulling the Serial Data (SDA) line LOW for the last clock cycle in the control byte. If no slave exists at that address or it is not ready to communicate, the data line is 1 indicating a not acknowledge condition.

When the control byte is sent and the RAA489118 acknowledges it, the second byte sent by the master must be a register address byte such as 0x14 for the ChargeCurrent register. The register address byte tells the RAA489118 which register the master writes or reads. See Table 1 for register details. When the RAA489118 receives a register address byte, it responds with an acknowledge.

5.5 Byte Format

Every byte on the SDA line must be eight bits long and must be followed by an ACK bit. Data is transferred with the Most Significant Bit (MSB) first and the Least Significant Bit (LSB) last. The LO Byte data is transferred before the HI Byte data. For example, when writing 0x41A0, 0xA0 is written first and 0x41 is written second.

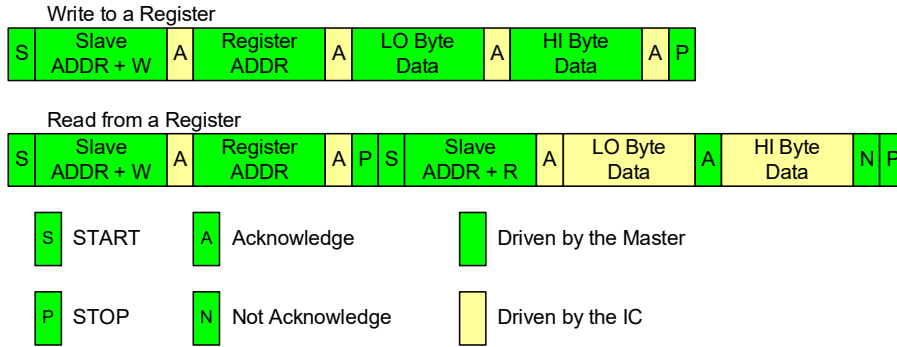

Figure 37. SMBus Read and Write Protocol

5.6 SMBus and I²C Compatibility

The RAA489118 SMBus minimum input logic high voltage is 1.3V, so it is compatible with I²C with pull-up power supplies higher than 1.3V.

The RAA489118 SMBus registers are 16 bits, so it is compatible with 16-bit I²C or 8-bit I²C with auto-increment capability.

5.7 SMBus Commands

The RAA489118 receives control inputs from the SMBus interface after Power-On Reset (POR). The serial interface complies with the [System Management Bus Specification](#). The RAA489118 uses the SMBus Read-word and Write-word protocols (see [Figure 37](#)) to communicate with the host system and a smart battery. The RAA489118 is an SMBus slave device and does not initiate communication on the bus. It responds to the 7-bit address 0b0001001_ as follows:

The Read and Write address for the RAA489118 is:

- Read address = 0b00010011 (0X13H)
- Write address = 0b00010010 (0X12H)

The data (SDA) and clock (SCL) pins have Schmitt-trigger inputs that can accommodate slow edges. Choose pull-up resistors for SDA and SCL to achieve rise times according to the SMBus specifications.

6. Registers

The register descriptions below are based on current-sensing resistors $R_{s1} = 10\text{m}\Omega$ and $R_{s2} = 5\text{m}\Omega$, unless otherwise specified.

6.1 Register Summary

Table 1. Register Summary

Register Names	Register Address	Read/Write	Number of Bits	Description	Default
ChargeCurrentLimit	0x14	R/W	11	[12:2], LSB size 8mA	256mA: CONFIG = VDD 0A: Otherwise
MaxSystemVoltage	0x15	R/W	12	[14:3], LSB size 16mV	8.4V 12.608V 16.8V 21.008V 25.2V 29.408V (Set by PROG pin)
Control7	0x36	R/W	3	[7], [1:0], configures various charger options	0x0000
Control6	0x37	R/W	8	[7:0], configures various charger options	0x0040 or 0x0043 ^[1]
Control5	0x38	R/W	16	Configures various charger options	0x0000
Control0	0x39	R/W	16	Configures various charger options	0x0000
Information1	0x3A	R	16	Indicates various charger statuses	0x0000
AdapterCurrentLimit2	0x3B	R/W	11	[12:2], LSB size 8mA	1.504A
Control1	0x3C	R/W	16	Configures various charger options	0x0200
Control2	0x3D	R/W	16	Configures various charger options	0x0000
MinSystemVoltage	0x3E	R/W	8	[13:6], LSB size 128mV	5.12V 7.68V 10.24V 12.80V 15.36V 17.92V (Set by PROG pin)
AdapterCurrentLimit1	0x3F	R/W	11	[12:2], LSB size 8mA	0.48A or 1.504A (Set by PROG pin)
Revision ID	0x44	R	8	Revision ID register - Read only	0x00
ACProchot#	0x47	R/W	6	[12:7] Adapter current PROCHOT# threshold, 256mA resolution for $10\text{m}\Omega R_{s1}$.	3.072A
DCProchot#	0x48	R/W	6	[13:8] Battery discharging current PROCHOT# threshold, 512mA resolution for $5\text{m}\Omega R_{s2}$.	4.096A
OTG Voltage	0x49	R/W	12	[14:3], LSB size 18mV, OTG mode voltage reference	5.004V
OTG Current	0x4A	R/W	9	[12:4], LSB size 32mA, OTG mode maximum current limit	0.512A

Table 1. Register Summary (Cont.)

Register Names	Register Address	Read/Write	Number of Bits	Description	Default
V _{IN} Voltage	0x4B	R/W	6	[13:8], LSB size 512mV, V _{IN} loop voltage reference	4.096V
Control3	0x4C	R/W	16	Configures various charger options	0x0000 or 0x0080 ^[2]
Information2	0x4D	R	16	Indicates various charger statuses	0x0000
Control4	0x4E	R/W	16	Configures various charger options	0x0000
Information3	0x90	R	1	[1] indicates pass-through mode status	0x0000
Manufacturer ID	0xFE	R	8	Manufacturer ID register – 0x49 - Read only	0x0049
Device ID	0xFF	R	8	Device ID register - Read only	0x0018

1. The default value for the VSYS UV field depends on the CONFIG pin state and whether powering up from battery.
2. Control3 Bit[7] is set by PROG pin, see [Table 16](#).

6.2 DAC Register Summary

Table 2. DAC Summary Table^[1]

ADDR Bit	Charge Current Limit (R _{s2} = 5mΩ)		Max System Voltage	Min System Voltage	Adapter Current Limit1 (R _{s1} = 10mΩ)	Adapter Current Limit2 (R _{s1} = 10mΩ)	V _{IN} Voltage (ADP Min Voltage or BAT Min Voltage)	ACProchot# (ACHOT) (R _{s1} = 10mΩ)	DCProchot# (DCHOT) (R _{s2} = 5mΩ)	OTG Voltage	OTG Current (R _{s1} = 10mΩ)
	0x14	0x15	0x15	0x3E	0x3F	0x3B	0x4B	0x47	0x48	0x49	0x4A
[0]	-	-	-	-	-	-	-	-	-	-	-
[1]	-	-	-	-	-	-	-	-	-	-	-
[2]	8mA	-	-	-	8mA	8mA	-	-	-	-	-
[3]	16mA	16mV	16mV	-	16mA	16mA	-	-	-	18mV	-
[4]	32mA	32mV	32mV	-	32mA	32mA	-	-	-	36mV	32mA
[5]	64mA	64mV	64mV	-	64mA	64mA	-	-	-	72mV	64mA
[6]	128mA	128mV	128mV	128mV	128mA	128mA	-	-	-	144mV	128mA
[7]	256mA	256mV	256mV	256mV	256mA	256mA	-	256mA	-	288mV	256mA
[8]	512mA	512mV	512mV	512mV	512mA	512mA	512mV	512mA	512mA	576mV	512mA
[9]	1024mA	1024mV	1024mV	1024mV	1024mA	1024mA	1024mV	1024mA	1024mA	1152mV	1024mA
[10]	2048mA	2048mV	2048mV	2048mV	2048mA	2048mA	2048mV	2048mA	2048mA	2304mV	2048mA
[11]	4096mA	4096mV	4096mV	4096mV	4096mA	4096mA	4096mV	4096mA	4096mA	4608mV	4096mA
[12]	8192mA	8192mV	8192mV	8192mV	8192mA	8192mA	8192mV	8192mA	8192mA	9216mV	8192mA
[13]	-	-	16384mV	16384mV	-	-	16384mV	-	16384mA	18432mV	-
[14]	-	-	0mV	-	-	-	-	-	-	0mV	-
[15]	-	-	-	-	-	-	-	-	-	-	-
Max	12.16A (0x17C0)		32.256V (0x3F00)	25.088V (0x3100)	12.16A (0x17C0)	12.16A (0x17C0)	27.648A (0x3600)	12.8A (0x1900)	25.6A (0x3200)	32.256V (0x3800)	8.192A (0x1000)
Default	CFG = VDD	CFG ≠ VDD	Set by PROG	Set by PROG	0.48A (0x00F0) or 1.504A (0x02F0) (Set by PROG)	1.504A (0x02F0)	4.096V (0x0800)	3.072A (0x0600)	4.096A (0x0800)	5.004V (0x08B0)	0.512A (0x0100)
	0.256A (0x0080)	0A (0x0000)									

1. Each of the DAC registers accepts any value, but only the valid register bits are written to the register and the voltage or current value is clamped at the indicated maximum. The RAA489118 accepts a 0V command for the MaxSystemVoltage register, but the register value does not change. The MinSystemVoltage value should be lower than the MaxSystemVoltage value.

6.3 Control Registers

The Control registers configure the operation of the RAA489118. To change the configuration after a POR, write to the appropriate control registers using the Write-word protocol shown in [Figure 37](#).

Table 3. Control0 Register 0x39H

Bit	Bit Name	Description
[15:13]	Forward Buck Phase Comparator Threshold Offset	<p>Bit[15:13] adjusts the phase comparator threshold offset for the forward buck mode.</p> <p>000 = 0mV (default) 001 = 1mV 010 = 2mV 011 = 3mV 100 = -4mV 101 = -3mV 110 = -2mV 111 = -1mV</p>
[12:10]	Forward Buck-boost, Forward Boost, and Reverse Boost Phase Comparator Threshold Offset	<p>Bit[12:10] adjusts the phase comparator threshold offset for the forward buck-boost, forward boost, and reverse boost modes.</p> <p>000 = 0mV (default) 001 = 0.5mV 010 = 1mV 011 = 1.5mV 100 = -2mV 101 = -1.5mV 110 = -1mV 111 = -0.5mV</p>
[9,8,0]	Reverse Buck and Reverse Buck-boost Phase Comparator Threshold Offset	<p>Bit[9,8,0] adjusts the phase comparator threshold offset for the reverse buck and reverse buck-boost modes.</p> <p>000 = 0mV (default) 001 = 1mV 010 = 2mV 011 = 3mV 100 = -4mV 101 = -3mV 110 = -2mV 111 = -1mV</p>
[7]	SMBus Timeout	<p>Bit[7] enables or disables the charger timeout function in NVDC charging mode (CONFIG pulled low). If the adapter is present and the RAA489118 does not receive a write command to the MaxSystemVoltage(0x15) or ChargeCurrentLimit(0x14) register within the time set by Control3 register Bit[12:11], RAA489118 terminates charging. After the timeout occurs, writing the MaxSystemVoltage(0x15) or ChargeCurrentLimit(0x14) register re-enables charging.</p> <p>0 = Enable the SMBus timeout function (default) 1 = Disable the SMBus timeout function</p> <p>For battery-charging only mode (CONFIG tied to VDD), this bit is irrelevant and the SMBus Timeout feature is always disabled.</p>
[6:5]	High-Side FET Short Detection Threshold	<p>Bit[6:5] configures the high-side FET short detection phase node voltage threshold while the low-side FET turns on.</p> <p>00 = 800mV (default) 01 = 500mV 10 = 600mV 11 = 400mV</p>

Table 3. Control0 Register 0x39H (Cont.)

Bit	Bit Name	Description																																													
[4:3]	DCProchot# Threshold in Battery Only Low Power Mode	Control7[1] and Control0[4:3] configure the battery discharging current DCProchot# threshold in battery only Low Power mode as indicated by Information1 register 0x3A Bit[15]. If PSYS is enabled, the battery discharge current DCProchot# threshold is instead set by the DCProchot# register 0x48 setting.																																													
		<table border="1"> <thead> <tr> <th>Control7[1]</th> <th>Control0[4:3]</th> <th>R_{s2} = 20mΩ (A)</th> <th>R_{s2} = 10mΩ (A)</th> <th>R_{s2} = 5mΩ (A)</th> </tr> </thead> <tbody> <tr> <td>0 (default)</td> <td>00 (default)</td> <td>6</td> <td>12</td> <td>24</td> </tr> <tr> <td>0</td> <td>01</td> <td>5</td> <td>10</td> <td>20</td> </tr> <tr> <td>0</td> <td>10</td> <td>4</td> <td>8</td> <td>16</td> </tr> <tr> <td>0</td> <td>11</td> <td>3</td> <td>6</td> <td>12</td> </tr> <tr> <td>1</td> <td>00</td> <td>2.5</td> <td>5</td> <td>10</td> </tr> <tr> <td>1</td> <td>01</td> <td>2</td> <td>4</td> <td>8</td> </tr> <tr> <td>1</td> <td>10</td> <td>1.5</td> <td>3</td> <td>6</td> </tr> <tr> <td>1</td> <td>11</td> <td>1</td> <td>2</td> <td>4</td> </tr> </tbody> </table>	Control7[1]	Control0[4:3]	R _{s2} = 20mΩ (A)	R _{s2} = 10mΩ (A)	R _{s2} = 5mΩ (A)	0 (default)	00 (default)	6	12	24	0	01	5	10	20	0	10	4	8	16	0	11	3	6	12	1	00	2.5	5	10	1	01	2	4	8	1	10	1.5	3	6	1	11	1	2	4
		Control7[1]	Control0[4:3]	R _{s2} = 20mΩ (A)	R _{s2} = 10mΩ (A)	R _{s2} = 5mΩ (A)																																									
		0 (default)	00 (default)	6	12	24																																									
		0	01	5	10	20																																									
		0	10	4	8	16																																									
		0	11	3	6	12																																									
		1	00	2.5	5	10																																									
		1	01	2	4	8																																									
1	10	1.5	3	6																																											
1	11	1	2	4																																											
[2]	Input Voltage Regulation Loop	Bit[2] enables or disables the input voltage regulation loop. 0 = Enable the input voltage regulation loop (default) 1 = Disable the input voltage regulation loop																																													
[1]	Force Buck Mode	Bit[1] disables or enables Force Buck mode. If the Force Buck mode bit is enabled, the Buck-Boost window narrows. 0 = Disable Force Buck mode (default) 1 = Enable Force Buck mode																																													

Table 4. Control1 Register 0x3CH

Bit	Bit Name	Description
[15:14]	General Purpose Comparator Assertion Debounce Time	Bit[15:14] configures the general purpose comparator assertion debounce time. 00 = 2μs (default) 01 = 12μs 10 = 2ms 11 = 5s
[13]	Exit Learn Mode Option	Bit[13] provides the option to Exit Learn mode when the battery voltage is lower than the MinSystemVoltage register setting. 0 = Stay in Learn mode even if V _{BAT} < MinSystemVoltage register setting (default) 1 = Exit Learn mode if V _{BAT} < MinSystemVoltage register setting
[12]	Learn Mode	Bit[12] enables or disables Battery Learn mode. 0 = Disable Battery Learn mode (default) 1 = Enable Battery Learn mode To enter Learn mode, the BATGONE pin must be low, that is, the battery must be present. Renesas recommends to disable the slew rate control (Control6 Bit[6] = 0) when using Learn mode.
[11]	OTG Function	Bit[11] enables or disables the OTG function. 0 = Disable the OTG function (default) 1 = Enable the OTG function

Table 4. Control1 Register 0x3CH (Cont.)

Bit	Bit Name	Description
[10]	Audio Filter	Bit[10] enables or disables the audio filter function. 0 = Disable the audio filter function (default) 1 = Enable the audio filter function
[9:8]	Switching Frequency	Bit[9:8] configures the switching frequency. 00 = 1MHz 01 = 839kHz 10 = 732kHz (default) 11 = 635kHz
[7]	Not Used	Not used
[6]	Turbo	Bit[6] enables or disables Turbo mode. When the turbo function is enabled, the BGATE FET turns on in Turbo mode. See Table 15 for the BGATE ON/OFF truth table. 0 = Enable Turbo mode (default) 1 = Disable Turbo mode
[5]	AMON/BMON Function	Bit[5] enables or disables the current monitor function AMON and BMON. 0 = Enable AMON/BMON (default) 1 = Disable AMON/BMON Bit[5] is only valid in Battery Only mode. When the adapter is present, AMON/BMON is automatically enabled and Bit[5] becomes invalid.
[4]	AMON or BMON	Bit[4] selects AMON or BMON as the AMON/BMON pin output. 0 = AMON (default) 1 = BMON
[3]	PSYS	Bit[3] enables or disables the system power monitor PSYS function. 0 = Disables the PSYS function (default) 1 = Enables the PSYS function
[2]	VSYS	Bit[2] enables or disables the buck-boost charger switching VSYS output. When disabled, the RAA489118 stops switching and forces the BGATE FET on. 0 = Enables VSYS output (default) 1 = Disables VSYS output
[1:0]	Low_VSYS_Prochot# Reference	Bit[1:0] configures the Low_VSYS_Prochot# assertion. 00 = 6.0V (default) 01 = 6.3V 10 = 6.6V 11 = 6.9V

Table 5. Control2 Register 0x3DH

Bit	Bit Name	Description															
[15:14]	Trickle Charging Current	Bit[15:14] configures the charging current in Trickle Charging mode. 00 = 512mA (default) 01 = 256mA 10 = 128mA 11 = 1024mA															
[13]	OTG Function Enable Debounce Time	Control2 Bit[13] and Control 3 Bit[0] configures the OTG function debounce time from when the RAA489118 receives the OTG enable command. <table border="1" style="margin-left: auto; margin-right: auto;"> <thead> <tr> <th>Control2[13]</th> <th>Control3[0]</th> <th>OTG Start-Up Delay</th> </tr> </thead> <tbody> <tr> <td>0 (default)</td> <td>0 (default)</td> <td>1.3s</td> </tr> <tr> <td>0</td> <td>1</td> <td>150ms</td> </tr> <tr> <td>1</td> <td>0</td> <td>150ms</td> </tr> <tr> <td>1</td> <td>1</td> <td>7.5ms</td> </tr> </tbody> </table>	Control2[13]	Control3[0]	OTG Start-Up Delay	0 (default)	0 (default)	1.3s	0	1	150ms	1	0	150ms	1	1	7.5ms
Control2[13]	Control3[0]	OTG Start-Up Delay															
0 (default)	0 (default)	1.3s															
0	1	150ms															
1	0	150ms															
1	1	7.5ms															
[12]	Two-Level Adapter Current Limit Function	Bit[12] enables or disables the two-level adapter current limit function. 0 = Disables the two-level current limit function (default) 1 = Enables the two-level current limit function															
[11]	Adapter Insertion to Switching Debounce	Bit[11] configures the debounce time from adapter insertion to when ACOK is asserted high. 0 = 1.3s (default) 1 = 150ms After VDD POR, for the first time the adapter is plugged in, the ASGATE turn-on delay is always 150ms, regardless of the Bit[11] setting. This bit sets the ASGATE turn-on delay only after ASGATE turns off at least one time when VDD is above its POR value and the Bit[11] default is 0 for 1.3s.															
[10:9]	Prochot# Debounce	Bit[10:9] configures the PROCHOT# debounce time before its assertion for ACProchot# and DCProchot#. The Low_VSYS_Prochot# has a fixed 8μs debounce time. 00: 7μs (default) 01: 100μs 10: 500μs 11: 1ms															
[8:6]	Prochot# Duration	Bit[8:6] configures the minimum duration of the PROCHOT# signal when asserted. 000 = 10ms (default) 001 = 20ms 010 = 15ms 011 = 5ms 100 = 1ms 101 = 500μs 110 = 100μs 111 = 0s															
[5]	ASGATE in OTG Mode	Bit[5] turns the ASGATE FET on or off in OTG mode. 0 = Turn on ASGATE in OTG mode (default) 1 = Turn off ASGATE in OTG mode															

Table 5. Control2 Register 0x3DH (Cont.)

Bit	Bit Name	Description
[4]	CMIN Reference	Bit[4] configures the general purpose comparator reference voltage when an adapter is attached. (In Battery-Only low-power mode, the reference voltage is 1.2V regardless of this bit.) 0 = 1.2V (default) 1 = 2V
[3]	General Purpose Comparator	Bit[3] enables or disables the general purpose comparator. 0 = Enable the general purpose comparator (default) 1 = Disable the general purpose comparator
[2]	CMOUT Polarity	Bit[2] configures the general purpose comparator output polarity when asserted. The comparator reference voltage is connected at the inverting input node. 0 = CMOUT is High when CMIN is higher than reference (default) 1 = CMOUT is Low when CMIN is higher than reference
[1:0]	Pass-Through Mode	Bit[1:0] configures the Pass-Through Mode (PTM). 00 = Disable normal PTM and forced PTM (default) 01 = Enable normal PTM 10 = Not Used 11 = Enable Forced PTM

Table 6. Control3 Register 0x4CH

Bit	Bit Name	Description ⁷
[15]	Reread PROG Pin Resistor	Bit[15] specifies whether to reread the PROG pin resistor. 0 = Reread PROG pin resistor (default) 1 = Do not reread PROG pin resistor
[14]	Reload ACLIM When Adapter Is Plugged In	Bit[14] specifies whether to reload the AdapterCurrentLimit1 register set by the PROG pin resistor. 0 = Reload the AdapterCurrentLimit1 register (default) 1 = Do not reload the AdapterCurrentLimit1 register
[13]	Autonomous Charging Termination Time	Bit[13] configures the autonomous charging termination time. 0 = 20ms (default) 1 = 200ms
[12:11]	Charger Timeout	Bit[12:11] configures the SMBus charger timeout time. 00 = 175s (default) 01 = 87.5s 10 = 43.75s 11 = 5s
[10]	BGATE Force OFF	Bit[10] configures the BGATE operation between normal and force off. 0 = Normal BGATE operation (default) 1 = Force BGATE MOSFET off
[9]	PSYS Gain	Bit[9] configures the system power monitor PSYS output gain. 0 = 0.236 μ A/W (default) 1 = 0.118 μ A/W

Table 6. Control3 Register 0x4CH (Cont.)

Bit	Bit Name	Description7															
[8]	Exit IDM Timer	Control7[7] and Control3[8] configure the Ideal Diode mode exit timer when the battery discharge current is less than 380mA.															
		<table border="1"> <thead> <tr> <th>Control3 [8]</th> <th>Control7 [7]</th> <th>IDM Timer</th> </tr> </thead> <tbody> <tr> <td>0 (default)</td> <td>0 (default)</td> <td>40ms</td> </tr> <tr> <td>0</td> <td>1</td> <td>5ms</td> </tr> <tr> <td>1</td> <td>0</td> <td>80ms</td> </tr> <tr> <td>1</td> <td>1</td> <td>1ms</td> </tr> </tbody> </table>	Control3 [8]	Control7 [7]	IDM Timer	0 (default)	0 (default)	40ms	0	1	5ms	1	0	80ms	1	1	1ms
		Control3 [8]	Control7 [7]	IDM Timer													
		0 (default)	0 (default)	40ms													
		0	1	5ms													
1	0	80ms															
1	1	1ms															
[7]	Charging Mode	Bit[7] selects the charging mode. 0 = Enable Autonomous Charging mode 1 = Battery charging current control through SMBus Default is determined by PROG and CONFIG.															
[6]	AC and CC Feedback Gain	Bit[6] configures AC and CC feedback gain for high current. 0 = x1 (default) 1 = x0.5															
[5]	Adapter-Side Current Limit Loop	Bit[5] enables or disables the adapter-side input current limit loops for forward and reverse/OTG modes. 0 = Enable adapter-side current limit loops (default) 1 = Disable adapter-side current limit loops															
[4]	Adapter-Side Current Limit Loop when BATGONE = 1	Bit[4] enables or disables the adapter-side current limit loop, in forward mode, when BATGONE = 1. 0 = Enable adapter-side current limit loop when BATGONE = 1 (default) 1 = Disable adapter-side current limit loop when BATGONE = 1															
[3]	AMON/BMON Direction	Bit[3] configures the AMON/BMON direction. 0 = Adapter current monitor/battery charging current monitor (default) 1 = OTG output current monitor/battery discharging current monitor															
[2]	Digital Reset	Bit[2] resets all SMBus register values to the POR default value. 0 = Idle (default) 1 = Reset															
[1]	Buck-Boost Stretch CCM Period	Control3 Bit[1] and Control4 Bit[8] configure the Buck-Boost stretch CCM period (T2 TIME).															
		<table border="1"> <thead> <tr> <th>Control3[1]</th> <th>Control4[8]</th> <th>T2 Time</th> </tr> </thead> <tbody> <tr> <td>0</td> <td>0</td> <td>0.6x (default)</td> </tr> <tr> <td>0</td> <td>1</td> <td>1x</td> </tr> <tr> <td>1</td> <td>0</td> <td>3x</td> </tr> <tr> <td>1</td> <td>1</td> <td>2x</td> </tr> </tbody> </table>	Control3[1]	Control4[8]	T2 Time	0	0	0.6x (default)	0	1	1x	1	0	3x	1	1	2x
		Control3[1]	Control4[8]	T2 Time													
		0	0	0.6x (default)													
		0	1	1x													
1	0	3x															
1	1	2x															
[0]	OTG Start-Up Delay	Refer to the description of Control2[13] in Table 5 .															

Table 7. Control4 Register 0x4EH

Bit	Bit Name	Description
[15:14]	Dither Enable	Bit[15:14] disables or selects the switching frequency dithering function. 00 = Disable dither (default) 01 = Dither 100 - 102% 10 = Dither 100 - 104% 11 = Dither 100 - 106%
[13]	ADP Discharge	Bit[13] enables or disables the ADP discharge function. Typical 10mA. 0 = Disable ADP discharge function (default) 1 = Enable ADP discharge function
[12]	VSYS Sink	Bit[12] enables or disables the VSYS discharge function. Typical 10mA. 0 = Disable VSYS discharge function (default) 1 = Enable VSYS discharge function
[11]	BGATE Tri-state	Bit[11] enables or disables the BGATE tri-state function. 0 = Disable BGATE tri-state (default) 1 = Enable BGATE tri-state
[10]	Buck-Boost Min T3 Time	Bit[10] selects the minimum T3 time when in the buck-boost mode. 0 = Long (default) 1 = Short
[9]	Buck-Boost T2 time in DCM	Bit[9] selects the buck-boost T2 time in the discontinuous-conduction mode (DCM). 0 = Reduced T2 time (increases switching frequency in DCM) (default) 1 = Normal T2 time
[8]	Buck-Boost Stretch CCM Period	Refer to the description of Control3 Bit[1] in Table 6 .
[7]	OTGCURRENT PROCHOT#	Bit[7] enables or disables PROCHOT# trigger with OTGCURRENT. 0 = Disable PROCHOT# trigger with OTGCURRENT (default) 1 = Enable PROCHOT# trigger with OTGCURRENT
[6]	BATGONE PROCHOT#	Bit[6] enables or disables PROCHOT# trigger with BATGONE. 0 = Disable PROCHOT# trigger with BATGONE (default) 1 = Enable PROCHOT# trigger with BATGONE
[5]	ACOK PROCHOT#	Bit[5] enables or disables PROCHOT# trigger with ACOK. 0 = Disable PROCHOT# trigger with ACOK (default) 1 = Enable PROCHOT# trigger with ACOK
[4]	Comparator PROCHOT#	Bit[4] enables or disables PROCHOT# trigger with General Purpose Comparator rising. 0 = Disable PROCHOT# trigger with General Purpose Comparator rising (default) 1 = Enable PROCHOT# trigger with General Purpose Comparator rising
[3:2]	ACOK falling or BATGONE Rising Debounce	Bit[3:2] configures the debounce time from ACOK falling or BATGONE rising to PROCHOT# trip. 00 = 2 μ s (default) 01 = 25 μ s 10 = 125 μ s 11 = 250 μ s

Table 7. Control4 Register 0x4EH (Cont.)

Bit	Bit Name	Description
[1]	PROCHOT# Clear	Bit[1] clears PROCHOT#. 0 = Idle (default) 1 = Clear PROCHOT#
[0]	PROCHOT# Latch	Bit[0] manually resets PROCHOT#. 0 = PROCHOT# signal auto-clear (default) 1 = Latch PROCHOT# low when tripped

Table 8. Control5 Register 0x38H

Bit	Bit Name	Descriptions
[15:14]	Internal Compensation Resistance	Bit[15:14] set the internal compensation resistance 00 = 1.26 K Ω (default) 01 = 773 Ω 10 = 3.6 K Ω 11 = 1.88 K Ω
[13]	Force BGATE On	Bit[13] enables or disables the Force BGATE On function 0 = Normal BGATE operation (default) 1 = Force BGATE On
[12]	Unused	-
[11]	VBAT Regulation Loop in OTG Mode	Bit[11] enables or disables the VBAT (VIN) voltage regulation during OTG (reverse) mode 0 = Disable (default) 1 = Enable
[10:8]	Two-Level ACLIM T2 Time	Bit[10:8] sets the T2 time corresponding to AdapterCurrentLimit2 when two-level adapter current limit function is enabled. 000 = 10 μ s (default) 001 = 100 μ s 010 = 500 μ s 011 = 1ms 100 = 300 μ s 101 = 750 μ s 110 = 2ms 111 = 10ms
[7]	VSYSOK 0.6V Comparator	Bit[7] enables or disables the 0.6V comparator. 0 = Enable (default) 1 = Disable
[6]	VSYSOK 10mA Current Source	Bit[6] enables or disables the 10mA current source. 0 = Enable (default) 1 = Disable
[5]	OTGPG/CMOUT Selection	Bit[5] selects the signal routed to the OTGPG/CMOUT pin. 0 = OTGPG (default) 1 = CMOUT
[4]	VSYSOV/OTGOV Control	Bit[4] enables or disables VSYS and OTG overvoltage protections. 0 = Enable (default) 1 = Disable

Table 8. Control5 Register 0x38H

Bit	Bit Name	Descriptions
[3]	Unused	-
[2:0]	Two-Level ACLIM T1 Time	Bit[2:0] sets the T1 time corresponding to AdapterCurrentLimit1 when two-level adapter current limit function is enabled. 000 = 10ms (default) 001 = 20ms 010 = 15ms 011 = 5ms 100 = 1ms 101 = 0.5ms 110 = 0.1ms 111 = 0ms

Table 9. Control6 Register 0x37H

Bit	Bit Name	Description
[15:8]	Not Used	Not used
[7]	Turn off BGATE at VSYSOV	Bit[7] configures the BGATE behavior during VSYS overvoltage. 0 = No action (default) 1 = Turn off BGATE
[6]	Slew Rate Control for Charge Current, Maximum System Voltage, and OTG Voltage	Bit[6] enables or disables the slew rate control for charger current, maximum system voltage, and OTG voltage. 0 = Disable the slew rate control 1 = Enable the slew rate control (default) Slew is limited to 1 DAC LSB per 16 clock cycles (1μs each). Nominal slew rates: 1mV/μs for system voltage, 0.5mA/μs for charging current with $R_{s2} = 5m\Omega$, and 1.125mV/μs for OTG voltage.
[5]	OTG Undervoltage Protection	Bit[5] enables or disables the OTG undervoltage protection 0 = Enable OTG undervoltage protection (default) 1 = Disable OTG undervoltage protection
[4]	Clear CMOUT Latch Data	Bit[4] clears the current CMOUT data when written to 1. The CMOUT latch data can be read from Bit[4] when Control6[3] = 0 (CMOUT Latch is enabled). 0 = Do not clear CMOUT latch data (default) 1 = Clear CMOUT latch data
[3]	CMOUT Latch	Bit[3] enables or disables the CMOUT latch function. 0 = Enable the CMOUT latch function (default) 1 = Disable the CMOUT latch function
[2:0]	VSYS Undervoltage Threshold	Bit[2:0] set VSYS under voltage threshold. 000 = Disable (default when CONFIG = VDD or when inserting the battery for the first time) 001 = 3.0V 010 = 3.9V 011 = 4.8V (default when CONFIG pulled low, except after inserting battery for the first time) 100 = 5.7V 101 = 6.6V 110 = 7.5V 111 = 8.4V

Table 10. Control7 Register 0x36H

Bit	Bit Name	Description															
[15:8]	Not Used	Not Used															
[7]	Exit IDM Timer	Control7[7] and Control3[8] configure the Ideal Diode mode exit timer when the battery discharge current is less than 380mA. <table border="1" style="margin-left: 20px;"> <thead> <tr> <th>Control3[8]</th> <th>Control7[7]</th> <th>IDM Timer</th> </tr> </thead> <tbody> <tr> <td>0 (default)</td> <td>0 (default)</td> <td>40ms (default)</td> </tr> <tr> <td>0</td> <td>1</td> <td>5ms</td> </tr> <tr> <td>1</td> <td>0</td> <td>80ms</td> </tr> <tr> <td>1</td> <td>1</td> <td>1ms</td> </tr> </tbody> </table>	Control3[8]	Control7[7]	IDM Timer	0 (default)	0 (default)	40ms (default)	0	1	5ms	1	0	80ms	1	1	1ms
Control3[8]	Control7[7]	IDM Timer															
0 (default)	0 (default)	40ms (default)															
0	1	5ms															
1	0	80ms															
1	1	1ms															
[6:2]	Not Used	Not Used															
[1]	Battery Only DCProchot# Threshold	Refer to the description of Control0[4:3] in Table 3 .															
[0]	VSYS ABS OV	VSYS absolute overvoltage protection 0 = Enabled (default) 1 = Disabled															

6.4 Information Registers

The Information registers contain SMBus readable information about manufacturing and Operating modes. The following tables identify the bit locations of the available information.

Table 11. Information1 Register 0x3AH

Bit	Description
[3:0]	Not used
[4]	Bit[4] indicates whether the Trickle Charging mode is active. 0 = Trickle Charging mode is not active 1 = Trickle Charging mode is active
[9:5]	Not used
[10]	Bit[10] indicates whether the Low_VSYS_Prochot# is tripped. 0 = Low_VSYS_Prochot# is not tripped 1 = Low_VSYS_Prochot# is tripped
[11]	Bit[11] indicates whether DCProchot# is tripped. 0 = DCProchot# is not tripped 1 = DCProchot# is tripped
[12]	Bit[12] indicates whether ACProchot#/OTGCURRENTProchot# is tripped. 0 = ACProchot#/OTGCURRENTProchot# is not tripped 1 = ACProchot#/OTGCURRENTProchot# is tripped

Table 11. Information1 Register 0x3AH (Cont.)

Bit	Description
[14:13]	Bit[14:13] indicates the active control loop. 00 = MaxSystemVoltage control loop is active 01 = Charging current loop is active 10 = Adapter current limit loop is active 11 = Input voltage loop is active
[15]	Bit[15] indicates whether the internal reference circuit is active. Bit[15] = 0 indicates that the RAA489118 is in Low Power mode. 0 = Reference is not active 1 = Reference is active

Table 12. Information2 Register 0x4DH

Bit	Description
[4:0]	Program Resister read out MaximumSystemVoltage MinimumSystemVoltage Adapter current limit
[7:5]	Bit[7:5] indicates the RAA489118 operation mode. 001 = Boost Mode 010 = Buck Mode 011 = Buck-Boost Mode 101 = OTG Boost Mode 110 = OTG Buck Mode 111 = OTG Buck-Boost Mode
[11:8]	Bit[11:8] indicates the RAA489118 state machine status. 0000 = OFF 0001 = BATTERY 0010 = ADAPTER 0011 = ACOK 0100 = VSYS 0101 = CHARGE 0110 = ENOTG 0111 = OTG 1000 = ENLDO5 1001 = Not Applicable 1010 = TRIM/ENCHREF 1011 = ACHRG 1100 = CAL 1101 = AGON/AGONTG 1110 = WAIT/PSYS 1111 = ADPPSYS
[12]	Bit[12] indicates the BATGONE pin status. 0 = Battery is present (BATGONE low) 1 = No battery (BATGONE high)
[13]	Bit[13] indicates the general purpose comparator output after debounce time. 0 = Comparator output is low 1 = Comparator output is high

Table 12. Information2 Register 0x4DH (Cont.)

Bit	Description
[14]	Bit[14] indicates the ACOK pin status. 0 = No adapter 1 = Adapter is present
[15]	Bit[15] indicates the CONFIG/PSYS state. 0 = CONFIG/PSYS pulled low (NVDC Charging with BFET) 1 = CONFIG/PSYS tied to VDD (Battery charging only with no BFET)

Table 13. Information3 Register 0x90H

Bit	Description
[15:2]	Not used
[1]	Bit[1] indicates the Pass-Through Mode (PTM) status. 0 = PTM is inactive 1 = PTM is active
[0]	Not used

7. Modulator Information

7.1 RAA489118 Buck-Boost Charger Modes of Operation

The RAA489118 buck-boost charger drives an external N-channel MOSFET bridge made of two transistor pairs as shown in Figure 38. The first pair, Q1 and Q2, is a buck arrangement with the transistor center tap connected to an inductor input as is the case with a buck converter. The second transistor pair, Q3 and Q4, is a boost arrangement with the transistor center tap connected to the output of the inductor as is the case with a boost converter. This arrangement supports bucking from a voltage input higher than the battery and also boosting from a voltage input lower than the battery.

Table 14. Operation Mode

Mode	Q1	Q2	Q3	Q4
Buck	Control FET	Sync. FET	OFF	ON
Boost	ON	OFF	Control FET	Sync. FET
Buck-Boost	Control FET	Sync. FET	Control FET	Sync. FET
OTG Buck	ON	OFF	Sync. FET	Control FET
OTG Boost	Sync. FET	Control FET	OFF	ON
OTG Buck-Boost	Sync. FET	Control FET	Sync. FET	Control FET
Pass-Through	ON	OFF	OFF	ON

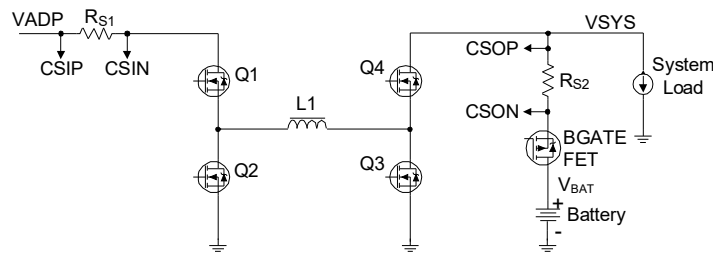

Figure 38. Buck-Boost Charger Topology

The RAA489118 optimizes the Operation mode transition algorithm by comparing the input and output voltage ratio and the load condition. When the adapter voltage V_{ADP} is rising and is higher than 91% of the system bus voltage $VSYS$, the RAA489118 transitions from Boost mode to Buck-Boost mode. If V_{ADP} is higher than 114% of $VSYS$, the RAA489118 forcedly transitions from Buck-Boost mode to Buck mode. At heavier loads, the mode transition point changes accordingly to accommodate the duty cycle change due to the power loss on the charger circuit.

When the adapter voltage V_{ADP} is falling and is lower than 108% of the system bus voltage $VSYS$, the RAA489118 transitions from Buck mode to Buck-Boost mode. If V_{ADP} is lower than 85% of $VSYS$, the RAA489118 transitions from Buck-Boost mode to Boost mode.

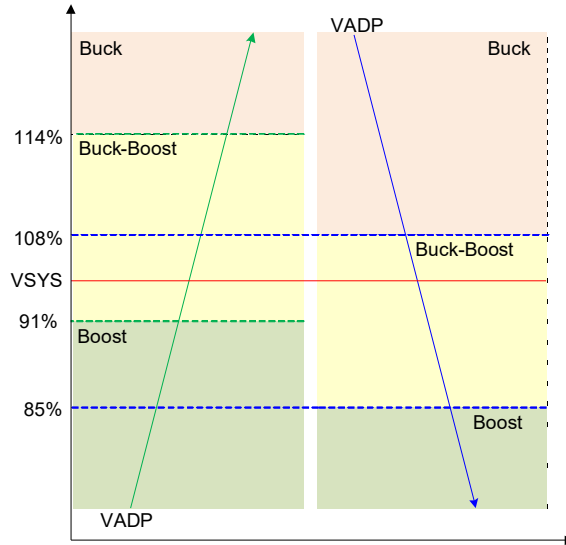

Figure 39. Operation Mode

When the Force Buck Mode is enabled by setting the Control0 Bit[1] to 1, the RAA489118 operates in Buck mode instead of Buck-Boost mode when VADP is 480mV higher than VSYS. Force Buck mode has a 240mV hysteresis window, so the RAA489118 operates in Buck-Boost mode when VADP is lower than VSYS + 240mV.

7.2 USB On-the-Go (USB OTG)

When the On-the-Go (OTG) function is enabled with the SMBus command and OTGEN pin, and if the battery voltage V_{BAT} is higher than 4.5V, the RAA489118 operates in OTG mode and Control2 Bit[5] controls ASGATE. BATGONE must be low to enable OTG mode.

When the OTG function is enabled with the SMBus command and OTGEN pin and if the battery voltage V_{BAT} is higher than 4.5V, the RAA489118 operates in Reverse Buck, Reverse Boost, or Reverse Buck-Boost mode.

When the RAA489118 receives the command to enable the OTG function, it starts switching after the debounce time set by Control2 register Bit[13] and Control3 register Bit[0]. When the OTG output voltage reaches the OTG output voltage set by register 0x49 Bit[14:3], OTG power-good OTGPG asserts to high. Control2 register Bit[5] can also be used to turn the ASGATE FET off to cut off the OTG output.

Before OTG mode starts switching, the CSIP pin voltage needs to drop below the OTG output overvoltage protection threshold (OTG Voltage DAC(0x49h) + 1.8V) first. The CSIP pin is the output sensing point in OTG mode.

The default OTG output voltage is 5.004V. The OTG Voltage register 0x49h configure the OTG output voltage.

The default OTG output current is 512mA when R_{S1} is 10mΩ. The OTG Current register 0x4Ah can be used to adjust the OTG output current limit.

The RAA489118 includes the OTG output undervoltage and overvoltage protection functions. The UVP threshold is OTG output voltage -1.8V and the OVP threshold is OTG output voltage +1.8V.

When UV is detected, the RAA489118 de-asserts OTGPG. After 32ms, it stops switching and turns off ASGATE. It resumes switching after the debounce time set by Control2 register Bit[13] and Control3 register Bit[0].

When OV is detected, the RAA489118 de-asserts OTGPG. It resumes switching when the OTG voltage drops below the OTG Voltage DAC value specified at 0x49.

BATGONE must be low to enable OTG mode.

7.3 Pass-Through Mode

Pass-Through Mode (PTM) is configured by Control2 register Bits[1:0]. When PTM (normal or forced) is enabled, the internal reference for the output voltage ramps to the input voltage, and switching continues until the output voltage is within $\pm 150\text{mV}$ of the input (adapter) voltage. Once the output voltage falls within this 300mV window, switching stops, Q1 and Q4 are set on, and Q2 and Q3 are turned off. When PTM is enabled, all protections are still active.

To disable PTM, set Control2 register Bits[1:0] = 00. On exiting PTM, the internal reference for the output voltage ramps to the MaximumSystemVoltage DAC value, and switching resumes. Normal PTM is also exited if any of the following criteria are encountered:

- Adapter OV triggers
- Ideal Diode Mode is entered
- The battery discharge current exceeds 600mA (for $R_{S2} = 5\text{m}\Omega$)
- VSYS absolute OV triggers

Forced PTM can only be exited by disabling PTM using Control2 Bits[1:0].

Before entering Pass-Through mode, the following is recommended:

1. Ensure CV mode operation;
2. Enable slew rate limiting by setting Control6 Bit[6] = 1; and
3. Change the MaximumSystemVoltage DAC to a value as close to the V_{ADP} voltage as possible.

When Q1 and Q4 are latching on to enter Pass-Through mode, the adapter current limit loop turns on for more than 1ms .

7.4 Modulator Control Loops

Figure 40 shows the modulator’s four main control loops. Each loop has a DAC register to provide settings as needed for each system.

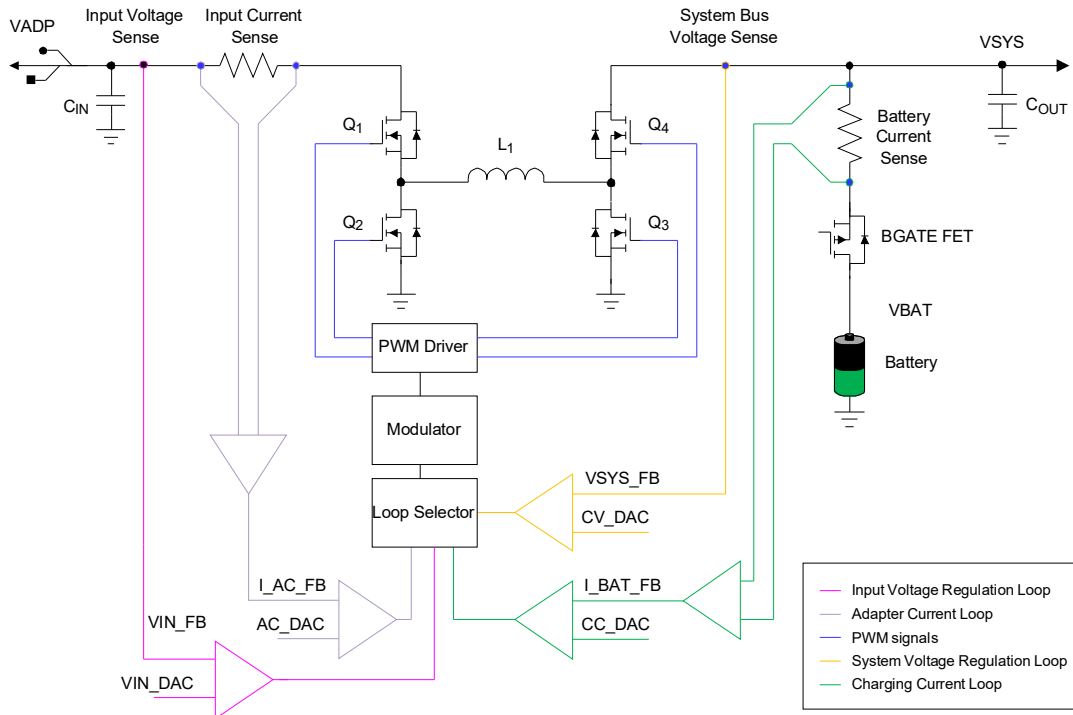

Figure 40. Charger Control Loops

7.4.1 Adapter Current Loop and Two-Level Current Limit

To set the adapter current limit, write a 16-bit AdapterCurrentLimit1 command to register address 0x3FH and, optionally, an AdapterCurrentLimit2 command to register address 0x3BH using the Write-word protocol. See Table 2 for the DAC summary of values.

The RAA489118 limits the adapter current by limiting the CSIP - CSIN voltage. By using the recommended R_{S1} current sense resistor of 10mΩ, the LSB of the register translates to 8mA of adapter current.

After adapter POR, the AdapterCurrentLimit1 register is reset to the value programmed through the PROG pin resistor. The AdapterCurrentLimit2 register is set to its default value of 1.504A or keeps the value that is written to it previously if the battery is present first. The AdapterCurrentLimit1 and AdapterCurrentLimit2 registers can be read back to verify their content. By default, the two level adapter current limit is disabled.

The AdapterCurrentLimit2 register has the same specification as the AdapterCurrentLimit1 register.

The two-level adapter current limit function can be enabled and disabled through SMBus Control2 register Bit[12] and the t1, t2 settings are configured by the Control5 register. When the two-level adapter current limit function is disabled, only the AdapterCurrentLimit1 value is used as the adapter current limit and AdapterCurrentLimit2 value is ignored.

In a real system, a Turbo event usually does not last very long. It is often no longer than milliseconds, a time length during which the adapter can supply current higher than its DC rating. The RAA489118 uses a two-level adapter current limit to fully take advantage of the surge capability of the adapter and minimize the power drawn from the battery.

Figure 41 shows the two SMBus programmable adapter current limit levels, AdapterCurrentLimit1 and AdapterCurrentLimit2, as well as the durations t1 and t2. The two-level adapter current limit function is initiated when the adapter current is less than 100mA lower than the AdapterCurrentLimit1 register setting. It starts at AdapterCurrentLimit2 for duration t2, then changes to AdapterCurrentLimit1 for duration t1 before repeating the pattern. These parameters can set the adapter current limit with an envelope that allows the adapter to temporarily output surge current without requiring the charger to enter Turbo mode. This operation maximizes battery life.

The AdapterCurrentLimit1 register value can be higher or lower than the AdapterCurrentLimit2 value.

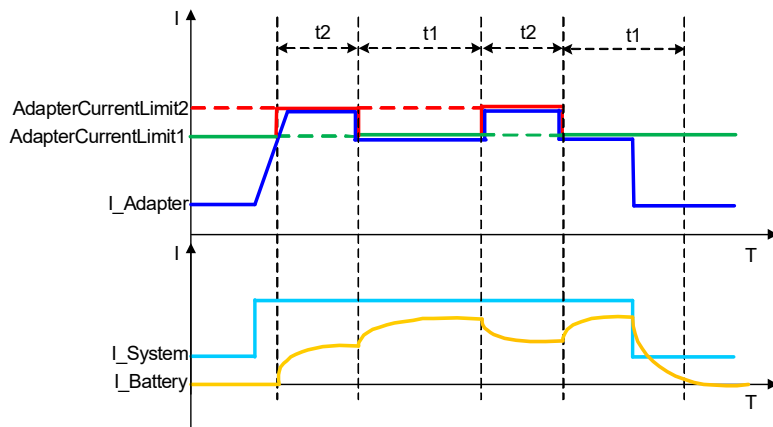

Figure 41. Two-Level Adapter Current Limit

7.4.2 USB-PD On-the-Go Output Current

The OTG output current regulation register DAC (Table 2) contains the SMBus readable and writable current that the current sense loop tries to regulate. This loop reuses the input current sense amplifier. If you are using the USB-PD Programmable Power Supply, this is the current limit loop. *Note:* Renesas recommends disabling OTG undervoltage protection when OTG current limiting mode is anticipated as part of normal operation.

7.4.3 Input Voltage Regulation Loop

7.4.3.1 Adapter Minimum Voltage

The input voltage regulation register DAC (Table 2) contains the SMBus readable and writable input voltage limit at which the input voltage loop tries to regulate when the input voltage is dropping. When the ADP is browning out or weak, the input voltage can droop and the input voltage loop tries to regulate to this setting by reducing battery charging current and then system power to try to hold up the input voltage. The system voltage might start to drop if the input power is not high enough to support the system.

7.4.3.2 USB-PD On-the-Go Minimum Battery Voltage

The input voltage regulation register DAC (Table 2) sets a minimum voltage for VBAT when operating in OTG mode. Control5 register Bit[11] enables and disables the battery voltage (VBAT) regulation loop. This regulation loop can be used to prevent over-discharging of a battery when operating in OTG mode (for example, USB-PD source mode).

7.4.4 USB-PD On-the-Go Output Voltage

The OTG output voltage regulation register DAC (Table 2) contains the SMBus readable and writable voltage that the voltage loop tries to regulate. This loop reuses the input voltage sense amp.

This register accepts any voltage value, but only the valid register bits are written to the register. The maximum value is clamped.

7.4.5 System Voltage Regulation and Trickle Charging

This loop works with two different voltage settings, MaxSystemVoltage and MinSystemVoltage.

The MaxSystemVoltage register sets the battery full charging voltage limit. In NVDC charging mode, the MaximumSystemVoltage register setting is also the system bus voltage regulation point when the battery is absent or when the battery is present but not in Charging mode.

The VSYS pin senses the battery voltage for maximum charging voltage regulation. The VSYS pin is also the system bus voltage regulation sense point.

If the battery is absent, the BGATE is turned off (no charging) and the system voltage is regulated to the same setting as the MaxSystemVoltage DAC(0x15h). To set the maximum charging voltage or the system regulating voltage, write a 16-bit MaxSystemVoltage command to register address 0x15H using the Write-word protocol shown in Figure 37.

The RAA489118 supports trickle charging to overly discharged batteries. It can activate the trickle charging function when the battery voltage is lower than MinSystemVoltage setting. The VBAT pin is the battery voltage sense point for Trickle Charge mode.

To enable Trickle Charging, set the ChargeCurrent register to a non-zero value. To disable trickle charging, set the ChargeCurrent register to 0. See Table 15 for trickle charging control logic.

The trickle charging current can be programmed to be 1024mA, 512mA, 256mA, or 128mA (with 5mΩ R_{s2}) through SMBus Control2 register Bit[15:14] as shown in Table 5.

In Trickle Charging mode, the RAA489118 regulates the trickle charging current through the buck-boost switcher. Provided that a BFET is present, another independent control loop drives the BFET gate so that the system voltage is maintained at the voltage set in the MinSystemVoltage register. If there is no BFET, the system voltage

might fall below the MinSystemVoltage setting. The VSYS pin is the system voltage sensing point in Trickle Charging mode.

When the battery voltage is charged to the MinSystemVoltage register value, the RAA489118 enters Fast Charging mode by limiting the charging current at the ChargeCurrentLimit register setting, which is typically higher than the trickle charge current.

7.4.6 Charging Current Loop

This loop uses the charge current DAC (see Table 2) to set the fast charging current limit. To set it, write a 16-bit ChargeCurrentLimit command to register address 0x14H (Table 1).

The RAA489118 limits the charging current by limiting the CSOP - CSON voltage. Therefore, the charge current depends on the R_{s2} resistor value. For example, if the current sense resistor R_{s2} is halved, the regulated charge current doubles. By using the current sense resistor $R_{s2} = 5m\Omega$, the LSB of the register translates to 8mA of charging current. The ChargeCurrentLimit register accepts any charging current command, but only the valid register bits are written to the register.

7.4.6.1 Reverse Mode Discharge Current

When the charger is in reverse mode of operation (OTG), there is a discharge current limit loop that is set by 2x the Charge Current limit register (0x14). This discharge current limit loop is in addition to the voltage regulation loop set by the OTG Voltage register, the current limit loop set by the OTG Current register, and the optional VBAT regulation loop set by the Input Voltage register. The discharge current limit loop is disabled when charge current limit (0x14h) is zero. When the charge current is a non-zero value, the charger limits the battery discharge current to be less than the discharge current limit (2x the Charge Current limit). This function can be used to limit inrush current from the battery when the OTG Voltage ramps up or down (in addition to the slew rate function).

7.4.7 Turbo Mode Support

Turbo mode refers to the system drawing more power than the power rating of the adapter.

If the adapter current reaches the AdapterCurrentLimit1 register set value (or the AdapterCurrentLimit2 register set value, if the two-level adapter current limit function is enabled), or the adapter input voltage drops to the Input Voltage Regulation Reference set by Input Voltage DAC register (0x4B), the RAA489118 limits the input power by regulating the adapter current at the AdapterCurrentLimit1/2 register set value, or by regulating the adapter voltage at the Input Voltage Regulation Reference point.

In Turbo mode, the system bus voltage VSYS drops automatically or the charging current drops automatically to limit the adapter input power. If the VSYS pin voltage is 150mV lower than the VBAT pin voltage, the BGATE FET turns on so that the battery supplies the rest of the power required by the system.

If the RAA489118 detects 250mA charging current or if the battery discharging current is less than 380mA for longer than the IDM exit timeout (80ms, 40ms, 5ms, or 1 ms), BGATE turns off and Turbo mode exits. The Turbo mode exit timer is configured through Control3 register 0x4C Bit[8] and Control7 register 0x36 Bit[7]. See Table 15 for BGATE control logic.

Table 15. BGATE On/Off Truth Table

Turbo (Control Bit)	ChargeCurrent Register	BGATE On/Off	
		System Load Not In Turbo Mode Range	System Load in Turbo Mode Range
0 = Enable 1 = Disable	0 = Zero 1 = Nonzero		
0	0	OFF	ON
0	1	ON for fast charge; Trickle charge is enabled	ON
1	0	OFF	OFF
1	1	ON for fast charge; Trickle charge is enabled	ON

7.5 R3 Modulator

The RAA489118 uses the patented Renesas Robust Ripple Regulator (R3) modulation scheme. The R3 modulator combines the best features of fixed frequency PWM and hysteretic PWM while eliminating many of their shortcomings. Figure 42 conceptually shows the R3 modulator circuit, and Figure 43 shows the operation principles in steady state.

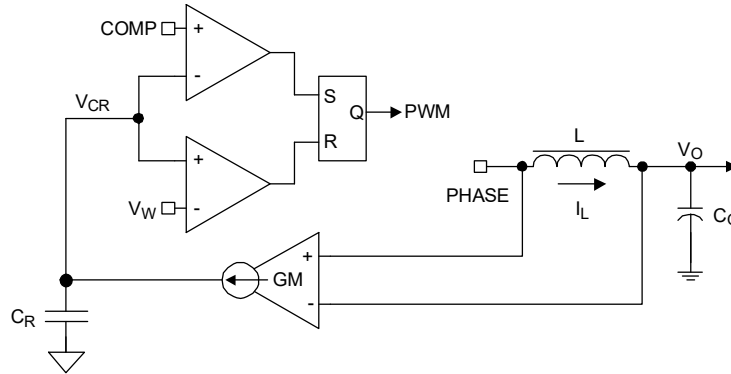

Figure 42. R3 Modulator

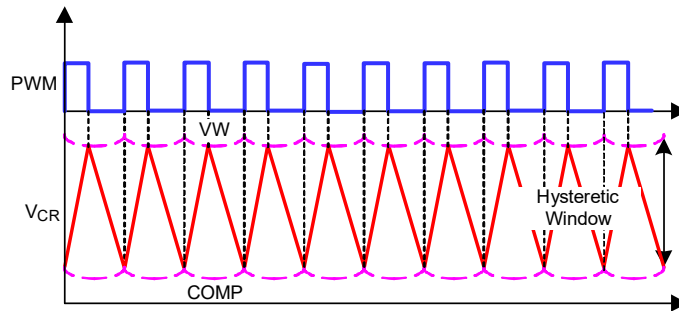

Figure 43. R3 Modulator Operation Principles In Steady State

A fixed voltage window (VW window) exists between VW and COMP. The modulator charges the ripple capacitor C_R with a current source equal to $g_m(V_{IN}-V_O)$ during PWM on-time and discharges the ripple capacitor C_R with a current source equal to $g_m V_O$ during PWM off-time, where g_m is a gain factor. The C_R voltage V_{CR} therefore emulates the inductor current waveform. The modulator turns off the PWM pulse when V_{CR} reaches VW and turns on the PWM pulse when it reaches COMP.

Because the modulator works with V_{CR} , which is large amplitude and noise free synthesized signal, it achieves lower phase jitter than conventional hysteretic mode modulator.

Figure 44 shows the operation principles during dynamic response. The COMP voltage rises during dynamic response, turning on PWM pulses earlier and more frequently temporarily, which allows for higher control loop bandwidth than conventional fixed frequency PWM modulators at the same steady state switching frequency.

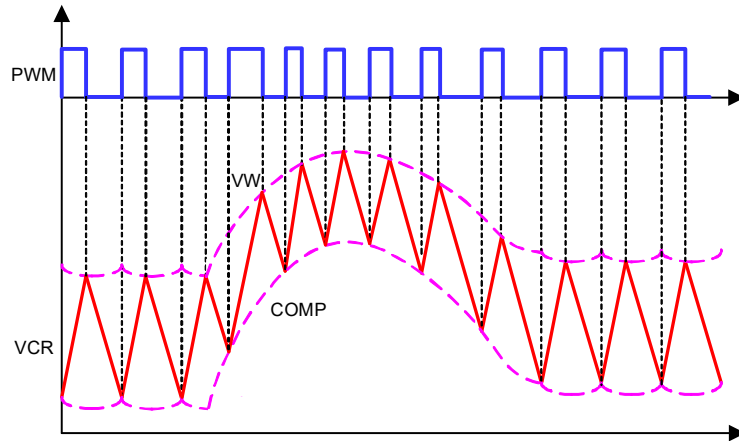

Figure 44. R3 Modulator Operation Principles In Dynamic Response

The R3 modulator can operate in Diode Emulation (DE) mode to increase light-load efficiency. In DE mode, the low-side MOSFET conducts when the current is flowing from source-to-drain and does not allow reverse current, which emulates a diode. As shown in Figure 45, when LGATE is on, the low-side MOSFET carries current and creates negative voltage on the phase node due to the voltage drop across the ON-resistance. The IC monitors the current by monitoring the phase node voltage. It turns off LGATE when the phase node voltage reaches zero to prevent the inductor current from reversing the direction and creating unnecessary power loss.

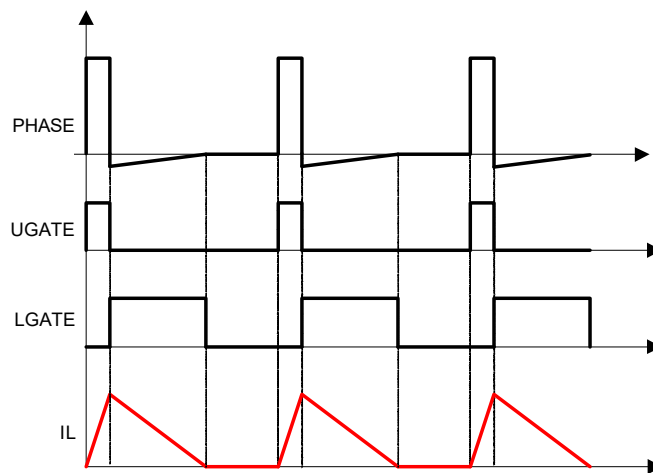

Figure 45. Diode Emulation

If the load current is light enough, as Figure 45 shows, the inductor current reaches and stays at zero before the next phase node pulse, and the regulator is in Discontinuous Conduction Mode (DCM). If the load current is heavy enough, the inductor current never reaches 0A, and the regulator is in Continuous Conduction Mode (CCM) although the controller is in DE mode.

Figure 46 shows the operation principle in DE mode at light load. The load gets incrementally lighter in the three cases from top to bottom. The PWM on-time is determined by the VW window size and therefore is the same, so the inductor current triangle is the same in the three cases. The R3 modulator clamps the ripple capacitor voltage V_{CR} in DE mode to mimic the inductor current. The COMP voltage takes longer to reach V_{CR} , which naturally stretches the switching period. The inductor current triangles move farther apart from each other so that the inductor current average value is equal to the load current. The reduced switching frequency helps increase light-load efficiency.

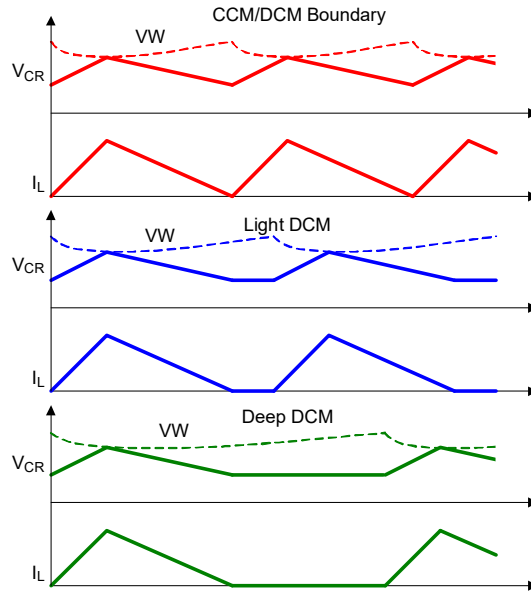

Figure 46. Period Stretching

8. Application Information

8.1 Soft-Start

The RAA489118 includes a low power LDO with nominal 4.6V output, with an input OR-ed from the VBAT and ADP pins. The RAA489118 also includes a high power LDO with nominal 5V output, with an input from the DCIN pin, which connects to both the adapter and the system bus through an external OR-ing diode circuit. Both LDO outputs are tied to the VDD pin to provide the bias power and gate drive power for the RAA489118. The VDDP pin is the RAA489118 gate drive power supply input. Use an R-C filter to generate the VDDP pin voltage from the VDD pin voltage.

When $V_{DD} > 2.7V$, the digital block is activated and the SMBus register is ready to communicate with the master controller.

With $V_{ADP} > 3.2V$ and after the 1.3s or 150ms debounce time, the RAA489118 uses a patented Renesas technique to check whether the input bus is shorted. If $CSIP < 2V$ or $ACIN < 0.8V$, ASGATE does not turn on. The input bus short protection adds an additional few milliseconds of delay, wherein the delay depends on the input capacitance. For adapter insertions after the initial one, the debounce time of 1.3s or 150ms is set by Control2 register Bit[11]. The debounce time for an initial adapter insertion is always 150ms. After the debounce time and the input bus short check, ASGATE starts turning on with 10 μ A of sink current.

Use a voltage divider from the adapter voltage to set the ACIN pin voltage. The RAA489118 monitors the ACIN pin voltage to determine the presence of the adapter. When $V_{DD} > 3.8V$, the ACIN pin voltage exceeds 0.6V, and ASGATE is fully turned on, the RAA489118 allows the external circuit to pull up the ACOK pin. When ACOK is asserted, the RAA489118 starts switching.

The ACOK is an open-drain output pin that indicates the presence and readiness of the adapter to supply power to the system bus. The RAA489118 actively pulls ACOK low in the absence of the adapter.

Before ASGATE turns ON, the RAA489118 sources 10 μ A of current out of the PROG pin and reads the pin voltage to determine the PROG resistor value. The PROG resistor programs the configurations of the RAA489118.

In Battery Only mode, the RAA489118 enters Low Power mode if only the battery is present. V_{DD} is 4.6V from the low power LDO to minimize power consumption.

8.2 Charging Mode Configuration

The RAA489118 can be configured to support a battery-charging-only application with no requirement for a battery FET (BFET). Connecting the CONFIG/PSYS pin to VDD configures the Buck-Boost charger to operate with no BFET. To configure the RAA489118 to support operation with a BFET, the CONFIG/PSYS pin should be pulled to ground with a PSYS resistor. For this case, the CONFIG/PSYS pin provides PSYS functionality.

- CONFIG/PSYS tied to VDD: Battery-charging-only mode with no BFET
- CONFIG/PSYS connected to PSYS resistor: NVDC charging with BFET support

8.2.1 Battery Charging Only (no BFET)

Figure 2 provides a circuit topology for an application that has no BFET, and which only provides battery charging. With no BFET, the system bus (VSYS) cannot be isolated from the battery (VBAT), and VSYS cannot be regulated separately from VBAT. With CONFIG/PSYS tied to VDD, the Buck-Boost charger is configured to support such a battery-charging-only application that has no BFET.

At POR with CONFIG/PSYS tied to VDD, the Charge Current (CC) DAC register (0x14) is initialized to 256mA (presuming $R_{s2} = 5\text{ m}\Omega$), and the charging mode is set for SMBus control (Control3 Bit[7] = 1). This causes the Buck-Boost charger to begin operation by charging an attached battery at the relatively low level of 256 mA. In typical usage, the charge current would be increased after initialization by writing a new value to the CC DAC register (0x14).

In battery-charging-only mode, there is no SMBus timeout function. Charging continues indefinitely and does not require any I²C interaction.

Note: Maintain the CC register at a nonzero value, because setting CC to zero disables the charge current limit.

8.2.2 NVDC Charging (with BFET)

Figure 3 provides a circuit topology for an application that has a BFET, which supports NVDC battery charging. The BFET provides the ability to isolate the system bus (VSYS) from the battery (VBAT), such that VSYS can be regulated independently of VBAT. With CONFIG/PSYS connected to a PSYS resistor, the Buck-Boost charger supports NVDC charging with a BFET.

If CONFIG/PSYS is connected to a PSYS resistor, the Charge Current DAC register (0x14) is initialized with 0A at POR. The BFET is turned off so that there is no battery charge current. The Buck-Boost charger initializes to CV control, such that VSYS is regulated at the MaxSystemVoltage level. Battery charging can be subsequently enabled by writing a nonzero value to the CC DAC register (0x14).

8.3 Programming Charger Option

The resistor from the PROG pin to GND programs the default number of battery cells in series, the default AdapterCurrentLimit1 register value, and the autonomous charging function. Table 16 shows the programming options.

Table 16. PROG Pin Programming Options

PROG-GND Resistance (kΩ)			Min V _{sys} (V)	Max V _{sys} (V)	Autonomous Charging ^[1]	Default ACLimit1 Reg (A)
Min	Typ. 1%	Max				
42.7	43.2	43.7	5.12	8.400	Yes	1.504
51.7	52.3	52.9			No	1.504
61.2	61.9	62.6			No	0.48
70.6	71.5	72.4	7.68	12.608	Yes	1.504
81.5	82.5	83.5			No	1.504
92	93.1	94.2			No	0.48
104	105	106	10.24	16.800	Yes	1.504
116	118	120			No	1.504
131	133	135			No	0.48
145	147	149	12.80	21.008	Yes	1.504
160	162	164			No	1.504
176	178	180			No	0.48
194	196	198	15.36	25.200	Yes	1.504
212	215	218			No	1.504
234	237	240			No	0.48
258	261	264	17.92	29.408	Yes	1.504
284	287	290			No	1.504
312	316	320			No	0.48

1. Autonomous charging mode is only configured if CONGIG/PSYS pin is pulled low at POR. If CONFIG/PSYS is tied high at POR, the charging mode is set to SMBus Charging regardless of the PROG resistance.

RAA489118 uses the default MaxVsystemVoltage register values in Table 1. The default switching frequency is 732kHz. If PSYS function is used, battery cell numbers can be mapped as 2/3/4/5/6/7 cells versus 8.4/12.6/16.8/21/25.2/29.4V accordingly in Table 1.

The switching frequency can be changed through SMBus Control1 register Bit[9:8] after POR. See the SMBus Control1 register programming table (Table 4) for a detailed description.

Before ASGATE turns on, the RAA489118 sources 10µA of current out of the PROG pin and reads the PROG pin voltage to determine the resistor value. However, application environmental noise can pollute the PROG pin voltage and cause incorrect readings. If noise is a concern, connect a capacitor from the PROG pin to GND to provide filtering. The resistor and the capacitor RC time constant should be less than 40µs so the PROG pin voltage can rise to steady state before the RAA489118 reads it.

If the RAA489118 is powered up from the battery, it does not read the PROG resistor unless PSYS is enabled through SMBus Control1 register Bit[3]. Whenever PSYS is enabled in Battery Only mode, the RAA489118 reads the PROG pin resistor and resets the configuration to the default.

When the adapter is plugged in, the RAA489118 resets the AdapterCurrentLimit1 register to the default by reading the PROG pin resistor if it was not read before, or by loading the previous readings. If PSYS is not enabled, the RAA489118 resets the MaxSystemVoltage register and MinSystemVoltage register to their default values according to the PROG pin setting. If PSYS is enabled, the RAA489118 keeps the values in these two registers.

By default, the adapter current sensing resistor R_{S1} is 10m Ω and the battery current sensing resistor R_{S2} is 5m Ω . Using this $R_1 = 10\text{m}\Omega$ and $R_{S2} = 5\text{m}\Omega$ option results in an 8mA/LSB correlation in the SMBus current commands. If the R_{S1} and R_{S2} differ from these default options, the SMBus command needs to be scaled accordingly to obtain the correct current. Smaller current sense resistor values reduce power loss while larger current sense resistor values give better accuracy.

8.4 Autonomous Charging Mode

Autonomous charging mode is only available in the NVDC charging configuration (CONFIG/PSYS pin pulled low at POR).

Autonomous Charging mode can be enabled or disabled through the programming charging option resistor or SMBus Control3 register Bit[7]. When Autonomous Charging mode is enabled, this mode can also be disabled by writing to the SMBus ChargeCurrentLimit or MaxSystemVoltage registers.

The RAA489118 enters Autonomous Charging mode when both the battery voltage is lower than MaxSystemVoltage - 180mV per cell for 1ms of debounce time and the BGATE MOSFET is on.

In Autonomous Charging mode, the RAA489118 starts to charge the battery with 4A (with $R_{S2} = 5\text{m}\Omega$), the PROCHOT# pin (Autonomous Charging mode indication pin) is pulled down to GND, and the SMBus charging timeout timer is disabled. The RAA489118 exits from Autonomous Charging mode when the battery charging current is less than 280mA (with $R_{S2} = 5\text{m}\Omega$) for 20ms or 200ms in CV loop. The autonomous charging termination time can be set by Control3 register Bit[13]. The RAA489118 re-enters Autonomous Charging mode when the battery voltage is discharged below MaxSystemVoltage - 180mV per cell. When the RAA489118 stays in Autonomous Charging mode for 12hrs, which means the battery charging current is higher than 280mA and the battery cannot be charged to MaxSystemVoltage for 12hrs, the RAA489118 stops charging the battery and exits Autonomous Charging mode.

8.5 Battery Ship Mode

The RAA489118 supports Battery Ship mode. When Control3 register Bit[10] is 1, the BGATE MOSFET stays off for Battery Ship mode.

Battery Ship mode sets the lowest power state for the IC. Ship mode can only be entered from Battery Only mode. To achieve the lowest power, several analog functions must be disabled. Many are disabled by default and do not need to be written, but all are listed for completeness. However, the power level can be customized for the system.

- Control1 0x3C
 - Bit[5] = 1 Disable IMON
 - Bit[3] = 0 Disable PSYS
- Control2 0x3D
 - Bit[3] = 1 Disable GP Comparator
- Control3 0x4C
 - Bit[10] = 1 Force BGATE Off

To exit Battery Ship mode, use the SMBus to change the control bits.

8.6 Diode Emulation Operation

In Diode Emulation (DE) mode, the RAA489118 uses a phase comparator to monitor the PHASE node voltage during the low-side switching FET on-time to detect the inductor current zero crossing. The phase comparator needs a minimum on-time of the low-side switching FET to recognize inductor current zero crossing. If the low-side switching FET on-time is too short for the phase comparator to successfully recognize the inductor zero crossing, the RAA489118 can lose DE ability. To prevent this, the RAA489118 uses a minimum low-side switching FET on-time. When the intended low-side switching FET on-time is shorter than the minimum value, the

RAA489118 stretches the switching period to keep the low-side switching FET on-time at the minimum value, which causes the CCM switching frequency to drop below the set point.

8.7 Battery Learn Mode

Use Battery Learn mode to supply the system power from the battery even when the adapter is plugged in, such as calibration of the battery fuel gauge.

The RAA489118 enters Battery Learn mode when it receives the SMBus Control command. When entering Battery Learn mode, the RAA489118 turns on the BGATE FET.

In Battery Learn mode, the RAA489118 turns on BGATE and keeps ASGATE on but turns off the buck-boost switcher regardless of whether the adapter is present.

The three ways of exiting Battery Learn mode are:

- Receive the Battery Learn mode exit command through SMBus
- The battery voltage is less than MinSystemVoltage register setting and Control1 Bit[13] = 1
- The BATGONE pin voltage goes from logic LOW to HIGH

In all these cases, the RAA489118 resumes switching immediately to supply power to the system bus from the adapter to prevent system voltage collapse.

Renesas recommends to disable the slew rate control (Control6 Bit[6] = 0) when using Learn mode.

8.8 Charger Timeout

The RAA489118 includes a timer to ensure the SMBus master is active and to prevent overcharging the battery. The charger timeout functionality is only available in the NVDC charging configuration (CONFIG/PSYS pulled low with PSYS resistor). The RAA489118 terminates charging by turning off the BGATE FET if the charger has not received a write command to the MaxSystemVoltage or ChargeCurrent register within 175s (SMBus Control3 register Bit[12:11] = 00). The charger timeout time can be configured through SMBus Control3 register Bit[12:11]. When charging is terminated by the timeout, the ChargeCurrent register retains its value instead of resetting to zero. If a timeout occurs, the MaxSystemVoltage or ChargeCurrent register must be written to re-enable charging.

The charger timeout function can be disabled using SMBus Control0 register Bit[7] as shown [Table 3](#).

8.9 Monitoring

8.9.1 Current Monitor

The RAA489118 provides an adapter current monitor/OTG current monitor or a battery charging current monitor/battery discharging current monitor through the AMON/BMON pin. The AMON output voltage is 18x (CSIP - CSIN) and 18x (CSIN - CSIP) voltage. The BMON output voltage is 18x (CSON - CSOP) and 36x (CSOP - CSON) voltage.

The AMON and BMON functions can be enabled or disabled through SMBus Control1 register Bit[5]. AMON or BMON can be selected through SMBus Control1 register Bit[4] and the AMON/BMON direction can be configured through SMBus Control3 register Bit[3] as [Table 4](#) shows.

8.9.2 PSYS Monitor

The RAA489118 PSYS pin provides a measure of the instantaneous power consumption of the entire platform. The PSYS pin outputs a current source described by [Equation 1](#).

$$(EQ. 1) \quad I_{PSYS} = K_{PSYS} \times (V_{ADP} \times I_{ADP} + V_{BAT} \times I_{BAT})$$

K_{PSYS} is based on the current sensing resistor $R_{S1} = 10m\Omega$ and $R_{S2} = 5m\Omega$. V_{ADP} is the adapter voltage in V, I_{ADP} is the adapter current in A, V_{BAT} is the battery voltage, and I_{BAT} is the battery discharging current. When the

battery is discharging, I_{BAT} is a positive value; when the battery is being charged, I_{BAT} is a negative value. The battery voltage V_{BAT} is detected through the CSON pin to maximize the power monitor accuracy in NVDC configuration Trickle Charge mode.

The R_{S1} to R_{S2} ratio must be 2:1 for valid power calculation. If the resistance values are higher (or lower) than the suggested values mentioned previously, K_{PSYS} is proportionally higher (or lower). As an example, if $R_{S1} = 5m\Omega$ and $R_{S2} = 2.5m\Omega$, the output current is half that above for the same power. If the PSYS information is not needed, any $R_{S1}:R_{S2}$ ratio is acceptable.

The default PSYS gain is set to $0.236\mu A/W$, and can be configured through SMBus Control3 register Bit[9].

The PSYS information includes the power loss of the charger circuit and the actual power delivered to the system. The resistor R_{PSYS} connected between the PSYS pin and GND converts the PSYS information from current to voltage.

PSYS accuracy limits and a typical accuracy scan are shown in Figure 47.

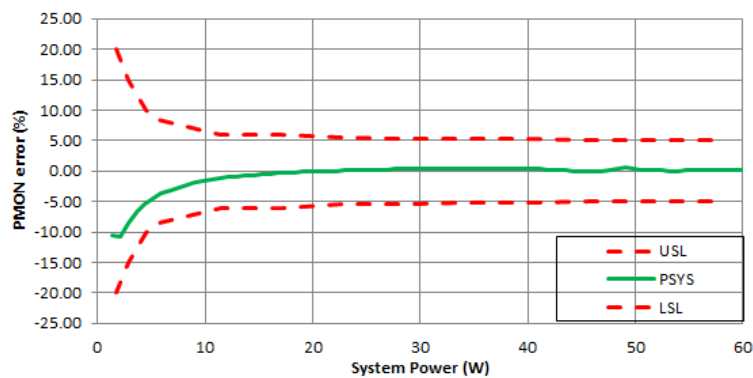

Figure 47. PSYS Accuracy and Limits

The PSYS function can be enabled or disabled through SMBus Control1 register Bit[3] as shown in Table 4.

8.9.3 PROCHOT#

PROCHOT# is an open-drain output used to support IMVP protocols. A PROCHOT# assertion is triggered if the adapter current exceeds the ACProchot# threshold, the battery discharge current exceeds a discharge current threshold, or VSYS falls below the Low_VSYS_Prochot# threshold. PROCHOT# can also, optionally, be asserted if the OTG Current exceeds a threshold, or by the BATGONE, ACOK, or General Purpose Comparator signals.

In Autonomous Charging mode, the PROCHOT# pin behaves as an indication pin and is pulled down to GND while autonomous-mode charging is active.

8.9.3.1 PROCHOT# for Adapter Overcurrent Conditions

To set the PROCHOT# assertion threshold for adapter overcurrent conditions, write a 16-bit ACProchot# command to register address 0x47 using the Write-word protocol shown in Figure 37 and the data format shown in Table 2. The ACProchot# register can be read back to verify its contents.

If the adapter current exceeds the ACProchot# register setting, the PROCHOT# signal asserts after the debounce time set by Control2 register Bit[10:9]. The PROCHOT# signal remains asserted for a minimum duration set by Control2 register Bit[8:6].

8.9.3.2 PROCHOT# for Battery Over Discharging Current Conditions

The threshold for the PROCHOT# Battery over-discharge condition depends on whether the battery charger is in low-power battery-only mode or in normal mode.

In normal mode, the PROCHOT# signal assertion threshold for battery over discharging current conditions is set by the DCProchot# value in DAC register 0x48.

In battery-only low-power mode with PSYS disabled, the battery over-discharging threshold is set by the DCProchot# level configured by Control0 register Bit[4:3] and Control7 register Bit[1]. However, if PSYS is enabled, the DCProchot# threshold is set by the value in DAC register 0x48.

If the battery discharging current exceeds the DCProchot# threshold, as set by the DCProchot# DAC register 0x48 or Control0 register Bit[4:3] and Control7 register Bit[1], the PROCHOT# signal asserts after the debounce time programmed by Control2 register Bit[10:9]. The PROCHOT# signal remains asserted for a minimum duration time determined by Control2 register Bit[8:6].

8.9.3.3 Low_VSYS_Prochot#

The Low_VSYS_Prochot# threshold is configured using Control1 register Bit[1:0], which provides four threshold settings. In battery-only mode, Low_VSYS_Prochot# only works if PSYS, or OTG is enabled.

8.9.3.4 Other PROCHOT# Triggers

The PROCHOT# signal can also be asserted if the OTG current is excessive, if BATGONE goes high (indicating no battery), if ACOK goes low (indicating no adapter) or if the General-Purpose Comparator triggers. Control4 Bits[7:4] are used to enable these additional PROCHOT# triggers. The OTGCurrent PROCHOT# threshold is the same as the adapter current PROCHOT# threshold ACProchot# specified in DAC register 0x48.

8.9.3.5 Setting PROCHOT# Debounce Time and Duration Time

The PROCHOT# signal debounce time for ACProchot# and DCProchot# is set by Control2 register Bit[10:9]. The low system (VSYS_LOW) voltage PROCHOT# has a fixed debounce time of 7µs.

The minimum duration of a PROCHOT# assertion triggered by Low_VSYS, ACProchot#, or DCProchot# is set by Control2 register Bit[8:6].

The debounce time for PROCHOT# assertions triggered by ACOK and BATGONE is set by Control4 register Bit[3:2].

8.9.3.6 Setting PROCHOT# Clear and Latch Control Bits

Control4 Bit[0] can be used to configure PROCHOT# to latch and hold its state. A latched PROCHOT# assertion can be cleared using Control4 Bit[1].

8.10 Stand-Alone Comparator

The RAA489118 includes a general purpose stand-alone comparator. The OTGEN/CMIN pin is the comparator input. The internal comparator reference is connected to the inverting input of the comparator and can be configured as 1.2V or 2V through SMBus Control2 register Bit[4]. The comparator output is the OTGPG/CMOUT pin. The output polarity can be configured through the SMBus register bit.

- When Control2 register Bit[2] = 0 for normal comparator output polarity, CMOUT = High if CMIN > Reference; CMOUT = Low if CMIN < Reference.
- When Control2 register Bit[2] = 1 for inversed comparator output polarity, CMOUT = Low if CMIN > Reference; CMOUT = High if CMIN < Reference.

By default in Battery Only mode, the stand-alone comparator is enabled. This comparator can be enabled/disabled in Battery Only mode using Control 2 Bit[3]. In Battery Only mode, the reference is always 1.2V, regardless of the value of Control2 Bit[4].

Table 17 shows the OTG mode and the stand-alone comparator truth table.

Table 17. OTG and Comparator Truth Table

Control1 Bit[11] OTG Function Enable/Disable	Control2 Bit[3] GP Comparator Enable/Disable	PIN-20 OTGEN/CMIN	PIN-26 OTGPG/CMOUT	Description
0	0	Comparator Input Pin CMIN	Comparator Output Pin CMOUT	OTG function is disabled. Comparator is enabled.
0	1	X	X	Both the OTG function and comparator are disabled.
1	0	Comparator Input Pin CMIN	Comparator Output Pin CMOUT	Both the OTG function and comparator are enabled. OTG function is enabled when V_{BAT} > 4.5V and Control1 register Bit[11] = 1 without OTG power-good pin indication. The device is in OTG mode while Information1 register 0x3A Bit[6:5] = 11.
1	1	OTG Enable Input Pin OTGEN	OTG Power-Good Indication Pin OTGPG	Comparator is disabled. OTG function is enabled when V_{BAT} > 4.5V and ENOTG pin = High and Control1 register Bit[11] = 1.

8.11 Protections^[1]

8.11.1 Adapter Overvoltage Protection

If the ADP pin voltage exceeds 33.3V for more than 10 μ s, an adapter overvoltage condition occurs. The RAA489118 turns off the ASGATE MOSFETs to isolate the adapter from the system, de-asserts the ACOK signal by pulling it low, and stops switching. BGATE turns on for the battery to support the system load. When the ADP voltage drops below 32.7V from more than 100 μ s, it starts to turn on ASGATE and start switching.

8.11.2 System Overvoltage Protection

The RAA489118 provides system rail overvoltage protection. If the system voltage VSYS is 1.6V higher than MaxSystemVoltage register set value, it declares the system overvoltage and stops switching. It resumes switching with no debounce time when VSYS drops 800mV below the system overvoltage threshold.

The RAA489118 provides VSYS absolute overvoltage protection. The absolute overvoltage rising threshold is 33.6V. If the system voltage VSYS is higher than 33.6V, it stops switching. When the VSYS drops to lower than 33.06V, it starts switching again.

8.11.3 System Voltage Rail Short Protection

The RAA489118 has a system rail short protection (VSYSOK) to prevent powering on the system rail into a short-circuit before switching starts. When the VSYS voltage is below 0.6V, the RAA489118 sources 10mA current (by default) from VDDP to charge VSYS before switching can start.

From the beginning of VSYSOK (VSYS rail short protection) to the start of switching in the VSYS state, the parts must go through multiple startup and initialization transition states, including turning on ASGATE FET. This initialization transition duration might take longer than it takes to charge the VSYS voltage to 0.6V using a 10mA source by the VSYSOK function. If this initialization transition duration is longer than the duration of charging VSYS above 0.6V, the charger must wait until the transition duration is completed before switching starts, and vice versa.

1. Nominal protection values are provided in this section. Refer to the Electrical Specifications for accurate values.

Conversely, the duration of charging VSYS above 0.6V, which depends on the leakage current and capacitance value at VSYS, varies per individual system design. If estimating the duration in a worst-case scenario is required, Renesas recommends testing the design to determine the following:

- If the initialization transition duration is longer than the duration of charging VSYS above 0.6V, add a 30% margin (considering $\pm 5\%$ clock tolerance) to estimate the duration.
- If the initialization transition duration is shorter than the duration of charging VSYS above 0.6V, check the tolerance of the VSYS capacitance or leakage current from VSYS downstream circuitry and then add a reasonable margin, such as 40% (considering $\pm 20\%$ cap tolerance), to estimate the duration.

After switching starts, the charger enters the Fault state if VSYS drops below 0.6V again at any time. After entering the Fault state, the charger stops switching and turns off ASGATE, and tries to start again with 1.3s or 150ms debounce time (configured by Control 2[11]).

For RAA489118 startup without battery pack present, Renesas recommends ensuring that there is no load on VSYS at startup.

After the initial POR, the VSYS rail short protection check can optionally be bypassed by disabling both the VSYSOK 0.6V Comparator using Control5 Bit[7] and the VSYSOK 10mA current source using Control5 Bit[6].

8.11.4 System Voltage Undervoltage Protection (for Short-Circuit Protection)

The charger has a fixed undervoltage protection on the system side that can be configured using Control 6[2:0].

The initial value of the VSYS undervoltage is set as follows:

- POR from battery: VSYS UV is 000 = disabled,
- POR from adapter with CONFIG tied to VDD: VSYS UV is 000 = disabled,
- POR from adapter with CONFIG pulled low: VSYS UV is 011 = 4.8V.

When the VSYS voltage falls to the VSYS UV threshold set by Control 6[2:0], there is a 100ms debounce before the charger enters FAULT state. After entering FAULT state, there is no switching and charger tries to start switching again after the 150ms or 1.3s debounce time (configurable by Control 2[11]).

8.11.5 Over-Temperature Protection

The RAA489118 stops switching for self protection when the junction temperature exceeds $+150^{\circ}\text{C}$. When the temperature falls below $+130^{\circ}\text{C}$ and after a 100 μs delay, the RAA489118 resumes switching.

8.12 Selecting the Power Source

The RAA489118 automatically selects the adapter and/or the battery as the source for system power.

The BGATE pin drives a P-channel MOSFET gate that connects/disconnects the battery from the system and the switcher.

The ASGATE pin drives a pair of back-to-back common source P-channel MOSFETs to connect/disconnect the adapter from the system and the battery. Use of the ASGATE pin is optional.

When the battery voltage V_{BAT} is higher than 2.4V and the adapter voltage V_{ADP} is less than 3.2V, the RAA489118 operates in Battery Only mode. During Battery Only mode, the RAA489118 turns on the BGATE FET to connect the battery to the system. In Battery Only mode, the RAA489118 consumes very low power (refer to the [Battery Current](#) specification). The battery discharging current monitor BMON can be turned on during this mode to monitor the battery discharging current. If the battery voltage V_{BAT} is higher than 4.5V, the system power monitor PSYS function also can be turned on during this mode to monitor system power.

In Battery Only mode, the USB OTG function can be enabled when the battery voltage V_{BAT} is higher than 4.5V. See [USB On-the-Go \(USB OTG\)](#) for details.

When the adapter voltage V_{ADP} is more than 3.2V, the RAA489118 turns on ASGATE. If VDD is higher than 3.8V, the RAA489118 enters Forward Buck, Forward Boost, or Forward Buck-Boost mode depending on the adapter

and system voltage VSYS duty cycle ratio. The system bus voltage is regulated at the voltage set on the MaxSystemVoltage register. If the charge current register is programmed (non-zero), the RAA489118 charges the battery either in Trickle Charging mode or Fast Charging mode, as long as BATGONE is low.

9. General Application Information

This design guide provides a high-level explanation of the steps necessary to design a single-phase power converter. It is assumed that the reader is familiar with many of the basic skills and techniques referenced in the following sections. In addition to this guide, Renesas provides complete reference designs that include schematics, bill of materials, and example board layouts.

9.1 Selecting the LC Output Filter

The duty cycle of an ideal buck converter in CCM is a function of the input and the output voltage. This relationship is written by [Equation 2](#):

$$(EQ. 2) \quad D = \frac{V_{OUT}}{V_{IN}}$$

Use [Equation 3](#) to calculate the output inductor peak-to-peak ripple current:

$$(EQ. 3) \quad I_{P-P} = \frac{V_{OUT} \cdot (1-D)}{f_{SW} \cdot L}$$

A typical step-down DC/DC converter has an I_{P-P} of 20% to 40% of the maximum DC output load current for a practical design. The value of I_{P-P} is selected based on several criteria such as MOSFET switching loss, inductor core loss, and the resistive loss of the inductor winding.

Use [Equation 4](#) to estimate the DC copper loss of the inductor, where I_{LOAD} is the converter output DC current.

$$(EQ. 4) \quad P_{COPPER} = I_{LOAD}^2 \cdot DCR$$

The copper loss can be significant, so select DCR carefully. Another factor to consider when choosing the inductor is its saturation characteristics at elevated temperatures. A saturated inductor can destroy circuit components.

A DC/DC buck regulator must have output capacitance C_O into which ripple current I_{P-P} can flow. Current I_{P-P} develops a corresponding ripple voltage V_{P-P} across C_O , which is the sum of the voltage drop across the capacitor ESR and of the voltage change stemming from charge moved in and out of the capacitor. Use [Equation 5](#) and [Equation 6](#) to calculate these two voltages:

$$(EQ. 5) \quad \Delta V_{ESR} = I_{P-P} \cdot ESR$$

$$(EQ. 6) \quad \Delta V_C = \frac{I_{P-P}}{8 \cdot C_O \cdot f_{SW}}$$

If the output of the converter has to support a load with high pulsating current, several capacitors need to be paralleled to reduce the total ESR until the required V_{P-P} is achieved. The inductance of the capacitor can cause a brief voltage dip if the load transient has an extremely high slew rate. Low inductance capacitors should be considered in this scenario. A capacitor dissipates heat as a function of RMS current and frequency. Ensure that I_{P-P} is shared by a sufficient quantity of paralleled capacitors so that they operate below the maximum rated RMS current at f_{SW} . Take into account that the rated value of a capacitor can fade as much as 50% as the DC voltage across it increases.

9.2 Selecting the Input Capacitor

The important parameters for input capacitance are the voltage rating and the RMS current rating. For reliable operation, select capacitors with voltage and current ratings above the maximum input voltage and that are capable of supplying the RMS current required by the switching circuit. Their voltage rating should be at least 1.25x greater than the maximum input voltage, while a voltage rating of 1.5x is a preferred rating. Figure 48 is a graph of the input capacitor RMS ripple current that is normalized relative to output load current. The graph is also a function of duty cycle and is adjusted for converter efficiency.

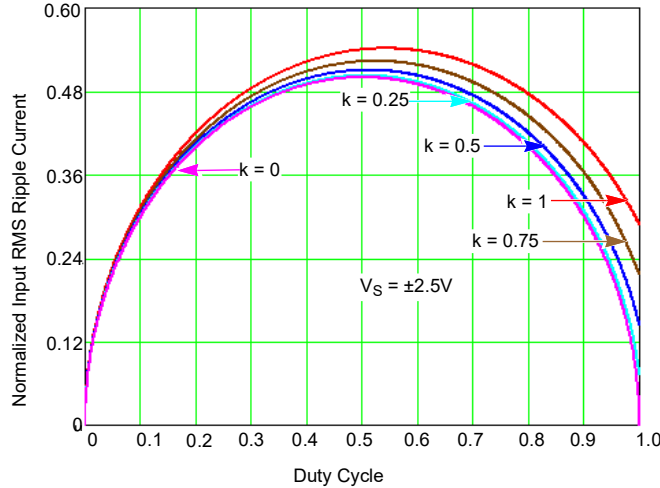

Figure 48. Normalized RMS Input Current at EFF = 1

Use Equation 7 to calculate the normalized RMS ripple current calculation:

$$(EQ. 7) \quad I_{C_{IN}(RMS,NORMALIZED)} = \frac{I_{MAX} \cdot \sqrt{D \cdot (1-D) + \frac{D \cdot k^2}{12}}}{I_{MAX}}$$

where:

- I_{MAX} is the maximum continuous I_{LOAD} of the converter
- k is a multiplier (0 to 1) corresponding to the inductor peak-to-peak ripple amplitude expressed as a ratio of I_{MAX} (0 to 1)
- D is the duty cycle that is adjusted to take into account the efficiency of the converter, which is calculated using Equation 8:

$$(EQ. 8) \quad D = \frac{V_{OUT}}{V_{IN} \cdot EFF}$$

In addition to the capacitance, some low ESL ceramic capacitance is recommended to decouple between the drain of the high-side MOSFET and the source of the low-side MOSFET.

9.3 Selecting the Switching Power MOSFET

Typically, a MOSFET cannot tolerate even brief excursions beyond its maximum drain-to-source voltage rating. The MOSFETs used in the power stage of the converter should have a maximum V_{DS} rating that exceeds both the sum of the upper voltage tolerance of the input power source and the voltage spike that occurs when the MOSFET switches off.

Several power MOSFETs that are optimized for DC/DC converter applications are readily available. The preferred high-side MOSFET emphasizes low gate charge so that the device spends the least amount of time dissipating power in the linear region. Unlike the low-side MOSFET, which has the drain-to-source voltage clamped by its body diode during turn off, the high-side MOSFET turns off with a V_{DS} of approximately $V_{IN} - V_{OUT}$, plus the

spike across it. The preferred low-side MOSFET emphasizes low $r_{DS(ON)}$ when fully saturated to minimize conduction loss. *Note:* This is an optimal configuration of MOSFET selection for low duty cycle applications ($D < 50\%$). For higher output, low input voltage solutions, a more balanced MOSFET selection for high-side and low-side devices might be required.

The power loss of the Low-Side (LS) MOSFET can be assumed to be conductive only and is calculated using [Equation 9](#):

$$(EQ. 9) \quad P_{CON_LS} \approx I_{LOAD}^2 \cdot r_{DS(ON)_LS} \cdot (1 - D)$$

Use [Equation 10](#) to calculate the conduction loss of the High-Side (HS) MOSFET:

$$(EQ. 10) \quad P_{CON_HS} = I_{LOAD}^2 \cdot r_{DS(ON)_HS} \cdot D$$

Use [Equation 11](#) to calculate the switching loss of the HS MOSFET:

$$(EQ. 11) \quad P_{SW_HS} = \frac{V_{IN} \cdot I_{VALLEY} \cdot t_{SW(ON)} \cdot f_{SW}}{2} + \frac{V_{IN} \cdot I_{PEAK} \cdot t_{SW(OFF)} \cdot f_{SW}}{2}$$

where:

- I_{VALLEY} is the difference of the DC component of the inductor current minus 1/2 of the inductor ripple current
- I_{PEAK} is the sum of the DC component of the inductor current plus 1/2 of the inductor ripple current
- $t_{SW(ON)}$ is the time required to drive the device into saturation
- $t_{SW(OFF)}$ is the time required to drive the device into cut-off

9.4 Selecting the Bootstrap Capacitor

The selection of the bootstrap capacitor is written by [Equation 12](#):

$$(EQ. 12) \quad C_{BOOT} = \frac{Q_g}{\Delta V_{BOOT}}$$

where:

- Q_g is the total gate charge required to turn on the high-side MOSFET
- ΔV_{BOOT} is the maximum allowed voltage decay across the boot capacitor each time the high-side MOSFET is switched on.

As an example, suppose the HS MOSFET has a total gate charge Q_g , of 25nC at $V_{GS} = 5V$ and a ΔV_{BOOT} of 200mV. The calculated bootstrap capacitance is 0.125 μ F; for a comfortable margin, select a capacitor that is double the calculated capacitance. In this example, 0.22 μ F is sufficient. Use an X7R or X5R ceramic capacitor. Renesas recommends using a bootstrap capacitor of 0.47 μ F (25V), which has an effective capacitance higher than 0.25 μ F at 5V and x50 effective high-side MOSFET gate capacitance.

9.5 Switching Power MOSFET Gate Capacitance

The RAA489118 includes an internal 5V LDO output at the VDD pin, which can be used to provide the switching MOSFET gate driver power through the VDDP pin with an RC filter. The 5V LDO output overcurrent protection threshold is 85mA, minimal (check EC table for the accurate value). When selecting the switching power MOSFET, consider the MOSFET gate capacitance carefully to avoid overloading the 5V LDO, especially in Buck-Boost mode when four MOSFETs are switching at the same time. For one MOSFET, use [Equation 13](#) to estimate the gate drive current:

$$(EQ. 13) \quad I_{driver} = Q_g \cdot f_{SW}$$

where:

- Q_g is the total gate charge, which can be found in the MOSFET datasheet
- f_{SW} is the switching frequency

Renesas recommends using a 2.2 μ F (10V) VDD/VDDP capacitor, which has an effective capacitance higher than 0.4 μ F at 5V and x1.6 effective capacitance at the BOOT pin at 5V.

9.6 DCIN Filter

An RC filter is connected at the DCIN pin. Renesas recommends connecting a 10 Ω DCIN resistor between the DCIN pin and the VADP/VSYS diodes, and connecting a 4.7 μ F DCIN capacitor to GND, which has an effective capacitance higher than 0.4 μ F at 28V.

9.7 Adapter Input Filter

The adapter cable parasitic inductance and capacitance can cause some voltage ringing or an overshoot spike at the adapter connector node when the adapter is hot plugged in. This voltage spike can damage the ASGATE MOSFET or the RAA489118 pins connecting to the adapter connector node. One low cost solution is to add an R-C snubber circuit at the adapter connector node to clamp the voltage spike as shown in Figure 49. A practical value of the R-C snubber is 2.2 Ω to 2.2 μ F, while the appropriate values and power rating should be carefully characterized based on the actual design. Renesas does not recommend adding a pure capacitor at the adapter connector node, which can cause an even larger voltage spike due to the adapter cable or the adapter current path parasitic inductance.

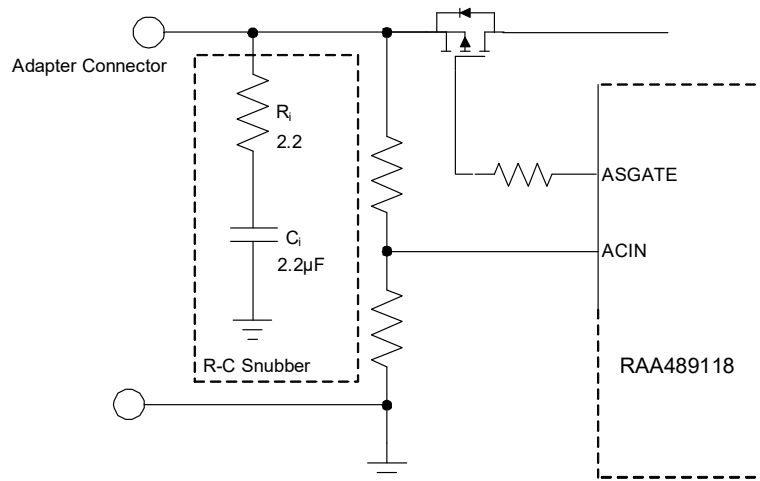
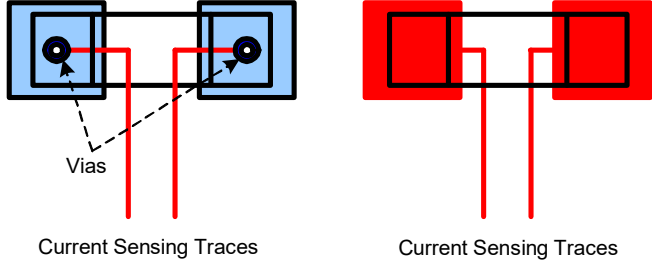
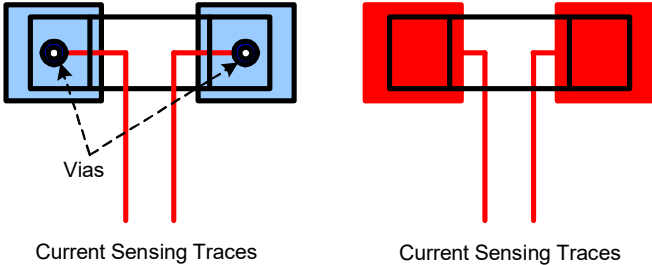

Figure 49. Adapter Input R-C Snubber Circuit

10. Layout

Pin Number	Pin Name	Layout Guidelines
Bottom Pad 33	GND	Connect this ground pad to the ground plane through a low impedance path. Use at least five vias to connect to the PCB ground planes to ensure sufficient thermal dissipation directly under the IC.
1	CSON	Run two dedicated traces with sufficient width in parallel (close to each other to minimize the loop area) from the two terminals of the battery current sensing resistor to the IC. Place the differential mode and common-mode RC filter components in the general proximity of the controller.
2	CSOP	<p>Route the current sensing traces through vias to connect the center of the pads; or route the traces into the pads from the inside of the current sensing resistor. The following drawings show the two preferred ways of routing current sensing traces.</p>  <p style="text-align: center;">Current Sensing Traces Current Sensing Traces</p>
3	VSYS	This signal pin provides feedback for the system bus voltage. Place the optional RC filter in the general proximity of the controller. Run a dedicated trace from the system bus to the pin and do not route near the switching traces. Do not share the same trace with the signal routing to the DCIN pin OR diodes and the CSOP trace.
4	BOOT2	Switching pin. Place the bootstrap capacitor in the general proximity of the controller. Use sufficiently wide traces. Avoid any sensitive analog signal traces from crossing over or getting close.
5	UGATE2	Run these two traces in parallel fashion with sufficient width. Avoid any sensitive analog signal traces from crossing over or getting close. Route the PHASE2 trace to the high-side MOSFET source pin instead of general copper.
6	PHASE2	<p>Place the IC close to the gate terminals of the switching MOSFETs and keep the gate drive signal traces short for a clean MOSFET drive. The IC can be placed on the opposite side of the switching MOSFETs.</p> <p>Place the output capacitors as close as possible to the switching high-side MOSFET drain and the low-side MOSFET source, and use shortest PCB trace connection. Place these capacitors on the same PCB layer with the MOSFETs instead of on different layers and using vias to make the connection.</p> <p>Place the inductor terminal to the switching high-side MOSFET source and low-side MOSFET drain terminal as close as possible. Minimize this phase node area to lower the electrical and magnetic field radiation but make this phase node area large enough to carry the current. Place the inductor and the switching MOSFETs on the same layer of the PCB.</p>
7	LGATE2	Switching pin. Run the LGATE2 trace in parallel with the UGATE2 and PHASE2 traces on the same PCB layer. Use sufficient width. Avoid any sensitive analog signal traces from crossing over or getting close.
8	VDDP	Place the decoupling capacitor in the general proximity of the controller. Run the trace connecting to the VDD pin with sufficient width.
9	LGATE1	Switching pin. Run the LGATE1 trace in parallel with the UGATE1 and PHASE1 traces on the same PCB layer. Use sufficient width. Avoid any sensitive analog signal traces from crossing over or getting close.

Pin Number	Pin Name	Layout Guidelines
10	PHASE1	Run these two traces in parallel fashion with sufficient width. Avoid any sensitive analog signal traces from crossing over or getting close. Route the PHASE1 trace to the high-side MOSFET source pin instead of general copper.
11	UGATE1	Place the IC close to the gate terminals of the switching MOSFETs and keep the gate drive signal traces short for a clean MOSFET drive. The IC can be placed on the opposite side of the switching MOSFETs. Place the input capacitors as close as possible to the switching high-side MOSFET drain and the low-side MOSFET source, and use shortest PCB trace connection. Place these capacitors on the same PCB layer with the MOSFETs instead of on different layers and using vias to make the connection. Place the inductor terminal to the switching high-side MOSFET source and low-side MOSFET drain terminal as close as possible. Minimize this phase node area to lower the electrical and magnetic field radiation but make this phase node area big enough to carry the current. Place the inductor and the switching MOSFETs on the same layer of the PCB.
12	BOOT1	Switching pin. Place the bootstrap capacitor in the general proximity of the controller. Use sufficient wide trace. Avoid any sensitive analog signal traces from crossing over or getting close.
13	ASGATE	Run this trace with sufficient width in parallel fashion with the ADP pin trace.
14	CSIN	Run two dedicated traces with sufficient width in parallel (close to each other to minimize the loop area) from the two terminals of the adapter current sensing resistor to the IC. Place the Differential mode and common-mode RC filter components in the general proximity of the controller. Route the current sensing traces through vias to connect the center of the pads or route the traces into the pads from the inside of the current sensing resistor. The following drawings show the two preferred ways of routing current sensing traces.
15	CSIP	 <p style="text-align: center;">Current Sensing Traces Current Sensing Traces</p>
16	ADP	Run this trace with sufficient width in parallel fashion with the ASGATE pin trace.
17	DCIN	Place the OR diodes and the RC filter in the general proximity of the controller. Run the VADP trace and VSYS trace to the OR diodes with sufficient width.
18	VDD	Place the RC filter connecting with the VDDP pin in the general proximity of the controller. Run the trace connecting to the VDDP pin with sufficient width.
19	ACIN	Place the voltage divider resistors and the optional decoupling capacitor in the general proximity of the controller.
20	OTGEN/CMIN	No special consideration.
21	SDA	Digital pins. No special consideration. Run the SDA and SCL traces in parallel.
22	SCL	
23	PROCHOT#	Digital pin, open-drain output. No special consideration.
24	ACOK	
25	BATGONE	Digital pin. Place the 100kΩ resistor series in the BATGONE signal trace and the optional decoupling capacitor in the general proximity of the controller.

Pin Number	Pin Name	Layout Guidelines
26	OTGPG/ CMOUT	Digital pin, open-drain output. No special consideration.
27	PROG	Signal pin. Place the PROG programming resistor in the general proximity of the controller.
28	COMP	Place the compensation components in the general proximity of the controller. Avoid any switching signal from crossing over or getting close.
29	AMON/BMON	No special consideration. Place the optional RC filter in the general proximity of the controller.
30	CONFIG/ PSYS	Dual-purpose pin: Configuration input or current source signal output. No special consideration.
31	VBAT	Place the optional R-C filter in the general proximity of the controller. Run a dedicated trace from the battery positive connection point to the IC.
32	BGATE	Use sufficient width trace from the IC to the BGATE MOSFET gate. Place the capacitor from BGATE to ground close to the MOSFET.

11. Package Outline Drawing

The package outline drawing is located at the end of this document and is accessible from the Renesas website. The package information is the most current data available and is subject to change without revision of this document.

12. Ordering Information

Part Number ^{[1][2]}	Part Marking	Package Description ^[3] (RoHS Compliant)	Pkg. Dwg #	Carrier Type ^[4]	Temp. Range
RAA489118ARGNP#AA0	489118 ARGNPA	32 Ld 4x4 TQFN	L32.4x4D	Tray	-10 to +100°C
RAA489118ARGNP#HA0				Reel, 6k	
RAA489118A3GNP#AA0	489118 A3GNPA			Tray	-40 to +105°C
RAA489118A3GNP#HA0				Reel, 6k	
RAA489118A3GNP#MA0				Reel, 1k	
RTKA489118DE0000BU	RAA489118 Evaluation Board - No BFET				
RTKA489118DE0010BU	RAA489118 Evaluation Board - with BFET				

1. These Pb-free plastic packaged products employ special Pb-free material sets, molding compounds/die attach materials, and 100% matte tin plate plus anneal (e3 termination finish, which is RoHS compliant and compatible with both SnPb and Pb-free soldering operations). Pb-free products are MSL classified at Pb-free peak reflow temperatures that meet or exceed the Pb-free requirements of IPC/JEDEC J-STD-020.
2. For the Moisture Sensitivity Level (MSL) see the [RAA489118](#) product page. For more information about MSL, see [TB363](#).
3. For the Pb-Free Reflow Profile, see [TB493](#).
4. See [TB347](#) for details about reel specifications.

13. Revision History

Revision	Date	Description
2.00	Oct 28, 2025	In section 3.3 Thermal Specifications, updated the values for the Thermal Resistance parameter.
1.03	Aug 21, 2025	Updated the waveforms in Figures 10, 11, 21, and 22. Updated Operation Mode values in Figure 39. Updated POD L32.4x4D to the latest version.
1.02	Jan 17, 2025	Added RAA489118A3GNP#MA0 to the Ordering Information and the PCB ECAD Design Information.
1.01	Oct 24, 2024	Updated POD L32.4x4D to the latest version. Added PCB ECAD Design Information.
1.00	Aug 9, 2024	Initial release

A. ECAD Design Information

This information supports the development of the PCB ECAD model for this device. It is intended to be used by PCB designers.

A.1 Part Number Indexing

Orderable Part Number	Number of Pins	Package Type	Package Code/POD Number
RAA489118ARGNP#AA0	32	TQFN	L32.4x4D
RAA489118ARGNP#HA0	32	TQFN	L32.4x4D
RAA489118A3GNP#AA0	32	TQFN	L32.4x4D
RAA489118A3GNP#HA0	32	TQFN	L32.4x4D
RAA489118A3GNP#MA0	32	TQFN	L32.4x4D

A.2 Symbol Pin Information

A.2.1 32-TQFN

Pin Number	Primary Pin Name	Primary Electrical Type	Alternate Pin Name(s)
1	CSON	Input	-
2	CSOP	Input	-
3	VSYS	Input	-
4	BOOT2	Power	-
5	UGATE2	Output	-
6	PHASE2	Power	-
7	LGATE2	Output	-
8	VDDP	Power	-
9	LGATE1	Output	-
10	PHASE1	Power	-
11	UGATE1	Output	-
12	BOOT1	Power	-
13	ASGATE	Output	-
14	CSIN	Input	-
15	CSIP	Input	-
16	ADP	Input	-
17	DCIN	Power	-
18	VDD	Power	-
19	ACIN	Input	-
20	OTGEN	Input	CMIN
21	SDA	I/O	-
22	SCL	I/O	-
23	PROCHOT#	Output	-
24	ACOK	Output	-
25	BATGONE	Input	-
26	OTGPG	Output	CMOUT
27	PROG	Input	-
28	COMP	Output	-
29	AMON	Output	BMON
30	CONFIG	I/O	PSYS
31	VBAT	Input	-

Pin Number	Primary Pin Name	Primary Electrical Type	Alternate Pin Name(s)
32	BGATE	Output	-
EPAD33	GND	Power	-

A.3 Symbol Parameters

Orderable Part Number	Qualification	Mounting Type	Min Input Voltage	Max Input Voltage	Min Output Voltage	Max Output Voltage	Min Operating Temperature	Max Operating Temperature	RoHS	Trickle Charging	Typ Switching Frequency	Switcher Configuration
RAA489118ARGNP#AA0	Consumer	SMD	3.9 V	30 V	2.4 V	30.8 V	-10° C	+100° C	Yes	Yes	732 KHz	Buck, Boost, and Buck-Boost
RAA489118ARGNP#HA0	Consumer	SMD	3.9 V	30 V	2.4 V	30.8 V	-10° C	+100° C	Yes	Yes	732 KHz	Buck, Boost, and Buck-Boost
RAA489118A3GNP#AA0	Industrial	SMD	3.9 V	30 V	2.4 V	30.8 V	-40° C	+105° C	Yes	Yes	732 KHz	Buck, Boost, and Buck-Boost
RAA489118A3GNP#HA0	Industrial	SMD	3.9 V	30 V	2.4 V	30.8 V	-40° C	+105° C	Yes	Yes	732 KHz	Buck, Boost, and Buck-Boost
RAA489118A3GNP#MA0	Industrial	SMD	3.9 V	30 V	2.4 V	30.8 V	-40° C	+105° C	Yes	Yes	732 KHz	Buck, Boost, and Buck-Boost

A.4 Footprint Design Information

A.4.1 32-TQFN

IPC Footprint Type	Package Code/ POD number	Number of Pins
QFN	L32.4x4D	32

Description	Dimension	Value (mm)	Diagram
Minimum body span (vertical side)	Dmin	3.95	
Maximum body span (vertical side)	Dmax	4.05	
Minimum body span (horizontal side)	Emin	3.95	
Maximum body span (horizontal side)	Emax	4.05	
Minimum Lead Width	Bmin	0.15	
Maximum Lead Width	Bmax	0.25	
Minimum Lead Length	Lmin	0.25	
Maximum Lead Length	Lmax	0.35	
Maximum Height	Amax	0.8	
Minimum Standoff Height	A1min	0	
Minimum Lead Thickness	cmin	0.15	
Maximum Lead Thickness	cmax	0.25	
Number of pins (vertical side)	PinCountD	8	
Number of pins (horizontal side)	PinCountE	8	
Distance between the center of any two adjacent pins (vertical side)	PitchD	0.4	
Distance between the center of any two adjacent pins (horizontal side)	PitchE	0.4	
Location of pin 1; S2 = corner of D side, C1 = center of E side	Pin1	S2	
Minimum thermal pad size (vertical side)	D2min	2.6	
Maximum thermal pad size (vertical side)	D2max	2.8	
Minimum thermal pad size (horizontal side)	E2min	2.6	
Maximum thermal pad size (horizontal side)	E2max	2.8	

Recommended Land Pattern			Diagram
Description	Dimension	Value (mm)	
Distance between left pad toe to right pad toe (horizontal side)	ZE	4.4	
Distance between top pad toe to bottom pad toe (vertical side)	ZD	4.4	
Distance between left pad heel to right pad heel (horizontal side)	GE	3.4	
Distance between top pad heel to bottom pad heel (vertical side)	GD	3.4	
Pad Width	X	0.2	
Pad Length	Y	0.5	

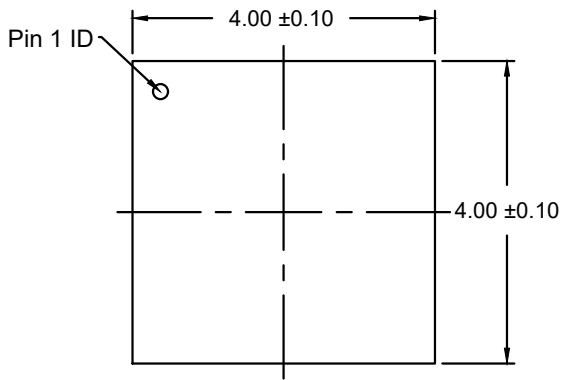

Top View

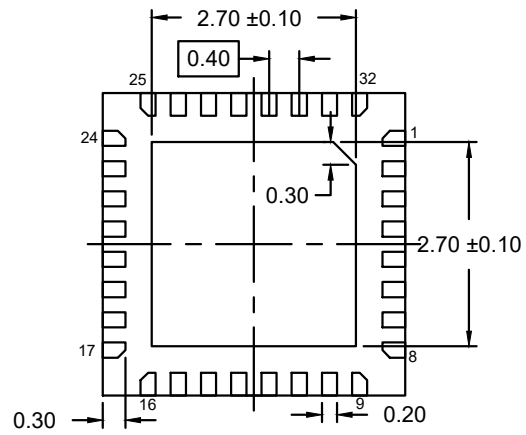

Bottom View

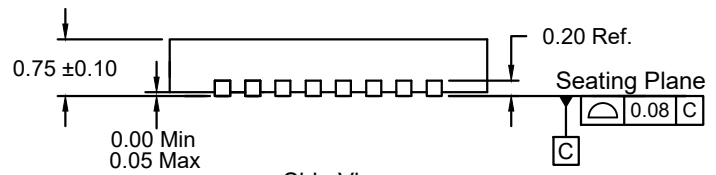

Side View

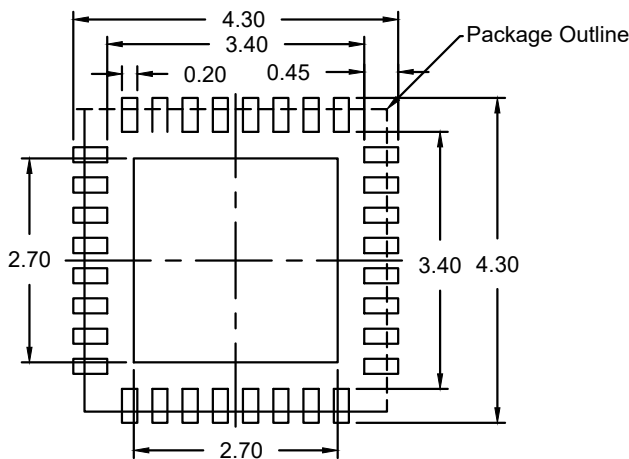

Typical Recommended Land Pattern

NOTES:

1. JEDEC compatible.
2. All dimensions are in mm and angles are in degrees.
3. Use ± 0.05 mm for the non-toleranced dimensions.
4. Numbers in () are for references only.

IMPORTANT NOTICE AND DISCLAIMER

RENESAS ELECTRONICS CORPORATION AND ITS SUBSIDIARIES (“RENESAS”) PROVIDES TECHNICAL SPECIFICATIONS AND RELIABILITY DATA (INCLUDING DATASHEETS), DESIGN RESOURCES (INCLUDING REFERENCE DESIGNS), APPLICATION OR OTHER DESIGN ADVICE, WEB TOOLS, SAFETY INFORMATION, AND OTHER RESOURCES “AS IS” AND WITH ALL FAULTS, AND DISCLAIMS ALL WARRANTIES, EXPRESS OR IMPLIED, INCLUDING, WITHOUT LIMITATION, ANY IMPLIED WARRANTIES OF MERCHANTABILITY, FITNESS FOR A PARTICULAR PURPOSE, OR NON-INFRINGEMENT OF THIRD-PARTY INTELLECTUAL PROPERTY RIGHTS.

These resources are intended for developers who are designing with Renesas products. You are solely responsible for (1) selecting the appropriate products for your application, (2) designing, validating, and testing your application, and (3) ensuring your application meets applicable standards, and any other safety, security, or other requirements. These resources are subject to change without notice. Renesas grants you permission to use these resources only to develop an application that uses Renesas products. Other reproduction or use of these resources is strictly prohibited. No license is granted to any other Renesas intellectual property or to any third-party intellectual property. Renesas disclaims responsibility for, and you will fully indemnify Renesas and its representatives against, any claims, damages, costs, losses, or liabilities arising from your use of these resources. Renesas' products are provided only subject to Renesas' Terms and Conditions of Sale or other applicable terms agreed to in writing. No use of any Renesas resources expands or otherwise alters any applicable warranties or warranty disclaimers for these products.

(Disclaimer Rev.1.01)

Corporate Headquarters

TOYOSU FORESIA, 3-2-24 Toyosu,
Koto-ku, Tokyo 135-0061, Japan
www.renesas.com

Trademarks

Renesas and the Renesas logo are trademarks of Renesas Electronics Corporation. All trademarks and registered trademarks are the property of their respective owners.

Contact Information

For further information on a product, technology, the most up-to-date version of a document, or your nearest sales office, please visit www.renesas.com/contact-us/.

Looking for pricing, stock, or lifecycle information?

Click below to explore more details on WIN SOURCE:

 [View SMBJ5338B on WIN SOURCE](#)

 [EVVO Information](#)

Optimize Your Supply Chain with WIN SOURCE Solutions

-  Global Sourcing Solution
-  Obsolete Management
-  Cost Control Management
-  Shortage Management
-  Alternative Solution
-  Excess Inventory Management