



**THE DATASHEET OF
MYRGP330060W21RC**



NMH1000

Magnetic switch

Rev. 3 — 18 October 2023

Product data sheet

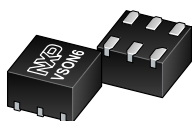

1 General description

The NMH1000 is a hall effect magnetic field switch. The switch is most sensitive to a vertical field passing through the top-to-bottom surfaces, orthogonal to the plane of the application printed circuit board. The switch operates at low voltage, low current, low output data rate, and is a small physical size.

Processing of input consists of functional blocks such as a configurable state machine, analog-to-voltage conversion of the input, and comparison to generate the bi-state output, arranged in linear succession.

2 Features and benefits

- Threshold selection 3-state hardware pin.
- Threshold selection data bit(s) in an I²C accessible register.
- Sample rate selection 3-state hardware pin.
- Sample rate selection data bit(s) in an I²C accessible register.
- Mode selection hardware pin to select between standalone or I²C serial interface.
- Mode selection data bit(s) in an I²C accessible register.
- Two types of output indicate the absence of a magnetic field as compared to an internally set threshold:
 - Binary state hardware pin.
 - Binary state data bit(s), configurable as assert-high or assert-low, in an I²C accessible register.

3 Applications

- **Electronic system wake-up:** Detecting the proximity vs. lack of proximity to an included magnet when the electronics are removed from its delivery packaging, to wake up the electronics.
- **Laptop lid open / closed:** Detecting the proximity vs. lack of proximity to a magnet mounted to laptop lid, to trigger a status change, for example turn on / off the display.
- **Door or window open / closed:** Detecting the proximity vs. lack of proximity to a magnet mounted to a door, lid, or window, to trigger a status change, for example an alarm.

4 Ordering information

Table 1. Ordering information

| Type number | Package | | Version |
|-------------|---------|--|-----------|
| | Name | Description | |
| NMH1000 | VSON | Very thin small outline package, no leads, 6 terminals, 0.5 mm pitch, 1.4 mm x 1.4 mm x 0.85 mm body | SOT2078-1 |



Refer to AN1902^[1] for additional information regarding use-case design and manufacturing recommendations.

5 Block diagram

The device consists of a monolithic die holding a Hall effect transducer, conversion, and comparison chain. Supporting blocks are described in [Section 5.1](#).

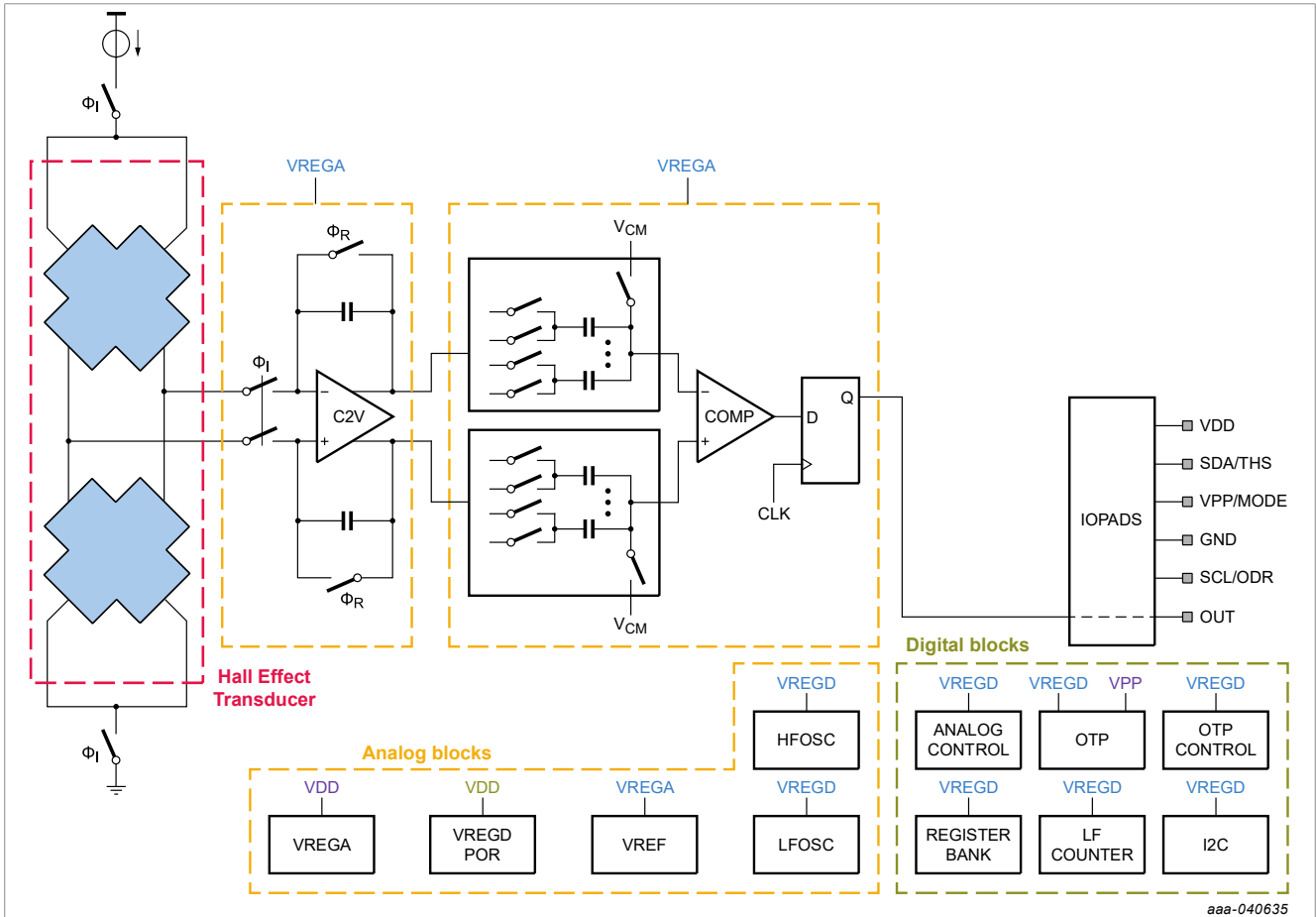

Figure 1. Block diagram

5.1 Block descriptions

- **Hall effect:** A transducer which generates a small charge which is proportional to the proximal magnetic flux density.
- **VREGA block:**
 - **C2V:** Converts the Hall effect charge to a voltage, which is stored onto the capacitor across the amplifier.
 - **Comparator:** Compares the voltage generated by the C2V with the pre-defined threshold voltage, then determines the state of the output Q, either Asserted or Cleared.
- **Analog blocks:**
 - **HF and LF Oscillator:** Configurable frequency (f_{HFO} and f_{LFO}) RC-Relaxation oscillators with independent trim bits for trimming.
 - **Regulators and references:** Regulators to step down the external supply for analog and digital circuits. Bandgap reference and current reference for biasing all analog module.
- **Digital blocks:**
 - **Analog control block:** Control signal generation for regulators and references, C2V, oscillators, comparator, for example, based on different operational modes.
 - **OTP:** A 16 x 8 bit array, it requires external V_{PPTM} for programming.
 - **OTP controller block:** Provides read and write control for OTP. All control signals needed by OTP are generated by this module.
 - **Register bank:** Provides the registers where users can write configurations or read status values.
 - **LF counter:** Counts the specific time depending on the sample rate (ODR) set by the user.
 - **I²C and test register block:** Includes the address decode logic and interrupt functions.

6 Pinning information

6.1 Pinning

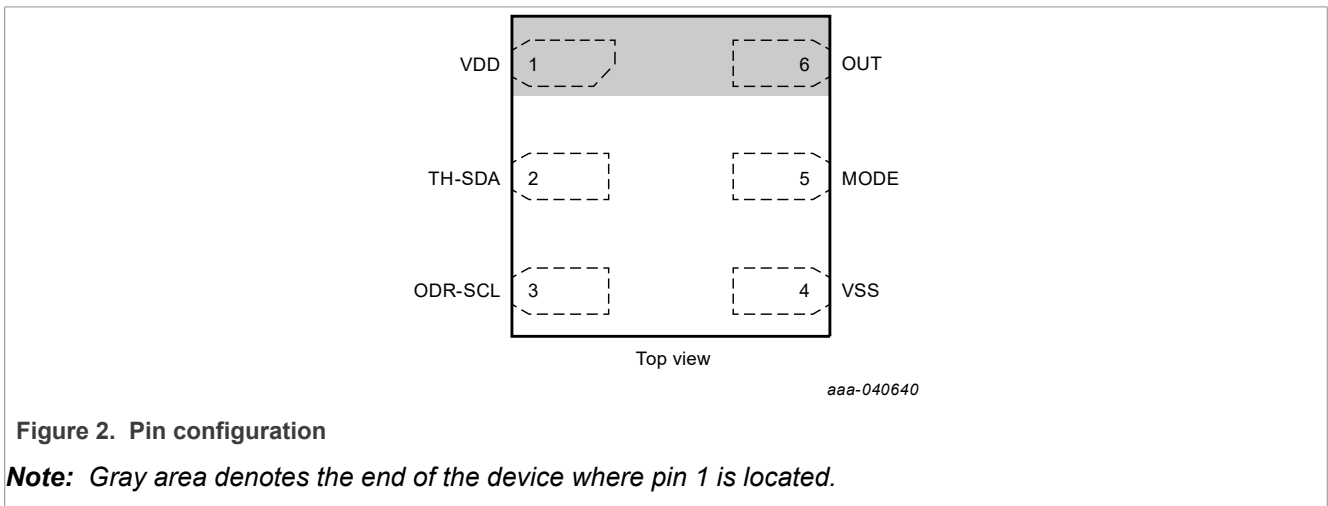

Figure 2. Pin configuration

Note: Gray area denotes the end of the device where pin 1 is located.

6.2 Pin description

Package and pin assignments support the options of magnetic field threshold and sample rate selections, based on the voltage applied to the MODE pin, upon appropriate voltage applied to the V_{DD} pin, relative to the V_{SS} pin.

Table 2. Pin description

| Symbol | Pin | Type | Description |
|------------------------|-----|--------|---|
| V _{DD} | 1 | Supply | Main supply voltage |
| TH-SDA ^[1] | 2 | I/O | Standalone mode: Threshold I ² C user mode: I ² C serial data |
| ODR-SCL ^[2] | 3 | I | Standalone mode: Sample rate I ² C user mode: I ² C serial clock |
| V _{SS} | 4 | Ground | Main ground |
| MODE ^[3] | 5 | I | Selects between Standalone or I ² C modes. |
| OUT ^[4] | 6 | O | Standalone mode: Output indicating absence of field |

[1] Three states: low state for medium threshold B_{O-M}, open circuit for low threshold B_{O-L}, or high state for high threshold B_{O-H}, relative to V_{SS}
 [2] Three states: low state for medium sample rate f_{ODR-M}, open circuit for low sample rate f_{ODR-L}, or high state for high sample rate f_{ODR-H}, relative to V_{SS}
 [3] Two states: low state for standalone, high state for I²C User Mode, relative to V_{SS}
 [4] Two states: default assert for magnet not present, clear for magnet present, relative to V_{SS}

6.3 Orientation

The device adheres to the convention of north magnetic field represented by positive/North polarity, orthogonal to the plane of the package body top surface and the arrows depict increasing strengths.

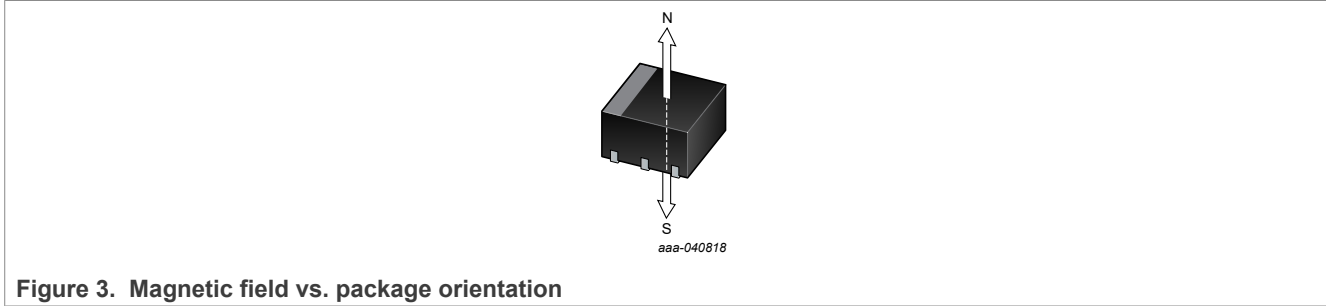

Figure 3. Magnetic field vs. package orientation

7 Functional description

7.1 Operating modes

7.1.1 Functional states

Figure 4 illustrates the functional states that the device transitions between.

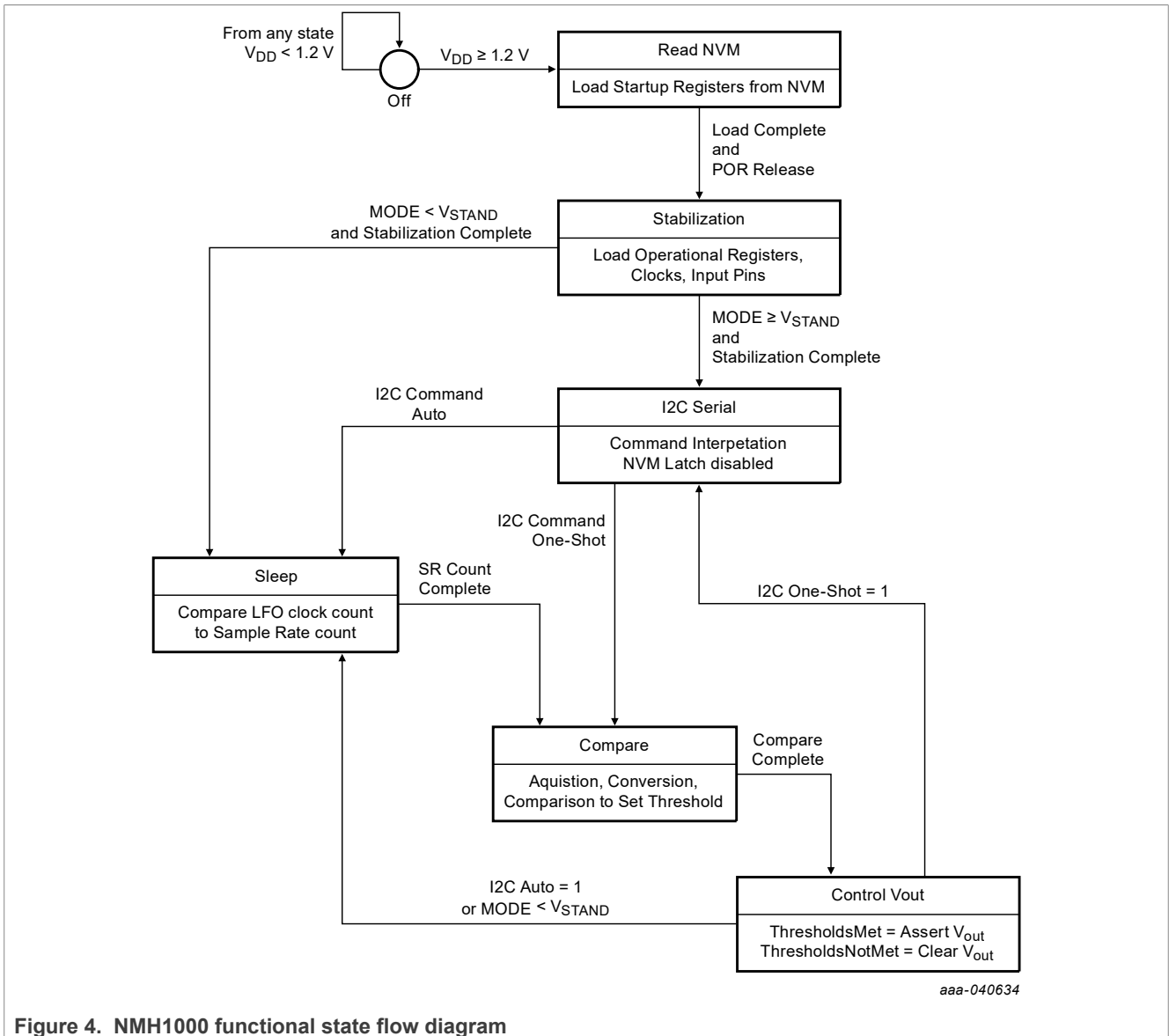

Figure 4. NMH1000 functional state flow diagram

7.1.2 Interface Operational Modes

The NMH1000 operates under one of two modes when appropriately configured as described in the following sections:

- I²C user mode.
- Standalone mode.

Entry into each of the two user modes is initiated by the voltage existing at the MODE pin at the time of the V_{DD} pin rising above V_{DDMIN}, and followed by a read of NVM Start-up register(s), both relative to the V_{SS} pin:

- MODE < V_{STAND} results in the device entering standalone mode and forcing OPMODE to 0.
- MODE ≥ V_{STAND} results in the device entering I²C user mode and forcing OPMODE to 1.

Transition from I²C user mode to standalone mode is initiated by the host writing I2C_DIS to 1, which results in OPMODE being forced to 0.

Note: The device reloads the NVM into operating registers after t_{RLDS} seconds from final power application, needing a duration of t_{RLDC}.

7.2 Threshold configurations

7.2.1 Fixed thresholds

In standalone mode, fixed thresholds with fixed hysteresis are selected by voltage applied to V_{TH} pin relative to V_{SS} pin.

7.2.1.1 Fixed threshold selection via V_{TH} pin voltage

Table 3. Fixed threshold selection

| V _{TH} | Threshold ^[1] |
|---|--------------------------|
| V _{TH} < V _{BO-L} | Medium magnetic field |
| V _{BO-L} ≤ V _{TH} ≤ V _{BO-H} | Low magnetic field |
| V _{TH} > V _{BO-H} | High magnetic field |

[1] See [Table 27](#).

7.2.2 User-defined threshold

In I²C mode, user-defined output assert threshold without hysteresis is selected by write to register bits, in units of BΔ in G/LSB:

Table 4. User-defined assert thresholds

| USER_ASSERT_THRESH[7:3] | Assert Threshold ^[1] - B _{OA} |
|-------------------------|--|
| 0 0 0 0 | 0 G |
| 0 0 0 1 | Lowest in-range magnetic field to assert the output |
| 1 1 1 1 | Highest in-range magnetic field to assert the output |

[1] See to [Section 10.6 "I2C user mode, output assertion"](#)

In I²C mode, user-defined output clear threshold without hysteresis is selected by write to register bits, in units of BΔ in G/LSB:

Table 5. User-defined output clear thresholds

| USER_CLEAR_THRESH[7:3] | Clear Threshold ^[1] - B _{OC} |
|------------------------|---|
| 0 0 0 0 | 0 G |
| 0 0 0 1 | Lowest in-range magnetic field to clear the output |
| 1 1 1 1 | Highest in-range magnetic field to clear the output |

[1] See to [Section 10.7 "I2C user mode, output clear"](#)

Note: If the `USER_ASSERT_THRESH` and `USER_CLEAR_THRESH` are set too close in value to each other, the intended hysteresis may cause the output to change states at unintended magnetic field strengths, or may cause the output to not change states at intended magnetic field strengths.

Be aware of the minimum hysteresis noted in [Table 32](#).

7.3 Sample rate configurations

7.3.1 Fixed sample rates

In standalone mode, the sample rate is the selected voltage applied to V_{ODR} pin relative to V_{SS} pin.

7.3.1.1 Sample rate selection via V_{ODR} pin voltage

Table 6. Sample rate selection

| V_{ODR} | Sample Rate ^[1] |
|---|----------------------------|
| $V_{ODR} < V_{fODR-L}$ | f_{ODR-M} |
| $V_{fODR-L} \leq V_{ODR} \leq V_{fODR-H}$ | f_{ODR-L} |
| $V_{ODR} > V_{fODR-H}$ | f_{ODR-H} |

[1] See [Section 10.2 "Clocks and rates"](#).

7.3.2 User-defined sample rate

In I²C mode, the user-defined sample rate is selected by a write to register bits:

Table 7. I²C mode user-defined sample rate

| USER_ODR[2:0] | Sample Rate |
|---------------|-----------------------|
| 0 0 0 | f_{ODR-L} |
| 0 0 1 | $5 \times f_{ODR-L}$ |
| 0 1 0 | f_{ODR-M} |
| 0 1 1 | $5 \times f_{ODR-M}$ |
| 1 0 0 | f_{ODR-H} |
| 1 0 1 | $5 \times f_{ODR-H}$ |
| 1 1 0 | $10 \times f_{ODR-H}$ |
| 1 1 1 | config. error |

7.4 Output control function description

7.4.1 Output hysteresis

Hysteresis is implemented as the magnetic field difference between the output being cleared versus the output being asserted.

- In Standalone mode, the hysteresis is a fixed difference.
- In I²C mode with the selection of one of the three fixed thresholds, the hysteresis is a fixed difference, equal to the Standalone mode hysteresis.

- In I²C mode with customer selected thresholds, the hysteresis is the result of the customer choices of output Clear threshold versus output Assert threshold.

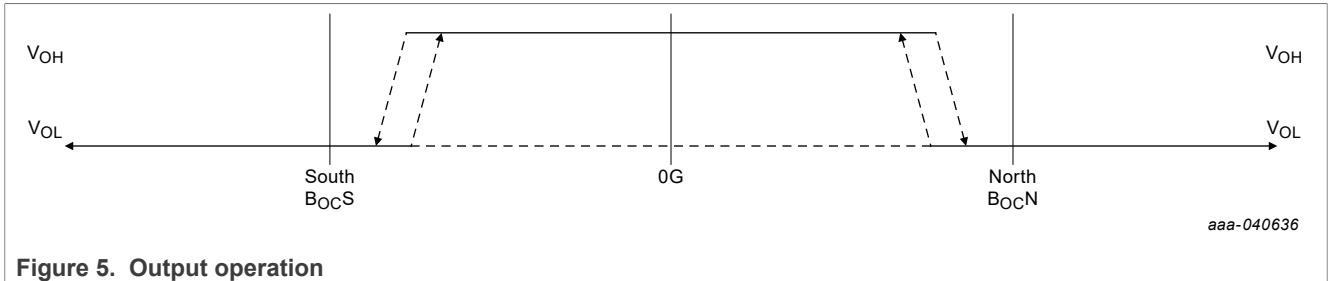

Figure 5. Output operation

7.4.2 Control Output State

7.4.2.1 Standalone mode output assert / clear states

In Standalone mode, the OUT pin asserts to high state upon the completion of the comparison stage, and the magnetic field is lower than the selected threshold Low, Medium, or High, minus the hysteresis.

In Standalone mode, the OUT pin is cleared to low state upon completion of the comparison stage, and the magnetic field is higher than the selected threshold Low, Medium, or High.

7.4.2.2 User-defined output assert / clear states

In I²C mode, the OUT pin and OUT-B register bit asserted and cleared states are selectable via the V_POL register bit.

Table 8. User-defined output assert and clear states

| V_POL | OUT pin assert / clear state |
|-------|---|
| 0 | OUT pin Assert = high / OUT pin Clear = low |
| 1 | OUT pin Assert = low / OUT pin Clear = high |

7.5 I²C serial data function description

7.5.1 I²C pin functions

Two signals support the I²C-bus:

- Serial Clock Line - SCL.
- Serial Data line - SDA.

SCL is input and used for clocking the data into or out from the SDA data line.

SDA is bidirectional and used for sending and receiving the data.

When the bus is free, both the lines idle high.

The I²C interface is compliant to the standard mode (100 kHz).

SDA and SCL both expect external pull-up resistors connected to V_{DD}.

- 1 kΩ minimum, board capacitance 20 pF maximum.

7.5.2 I²C timing diagram

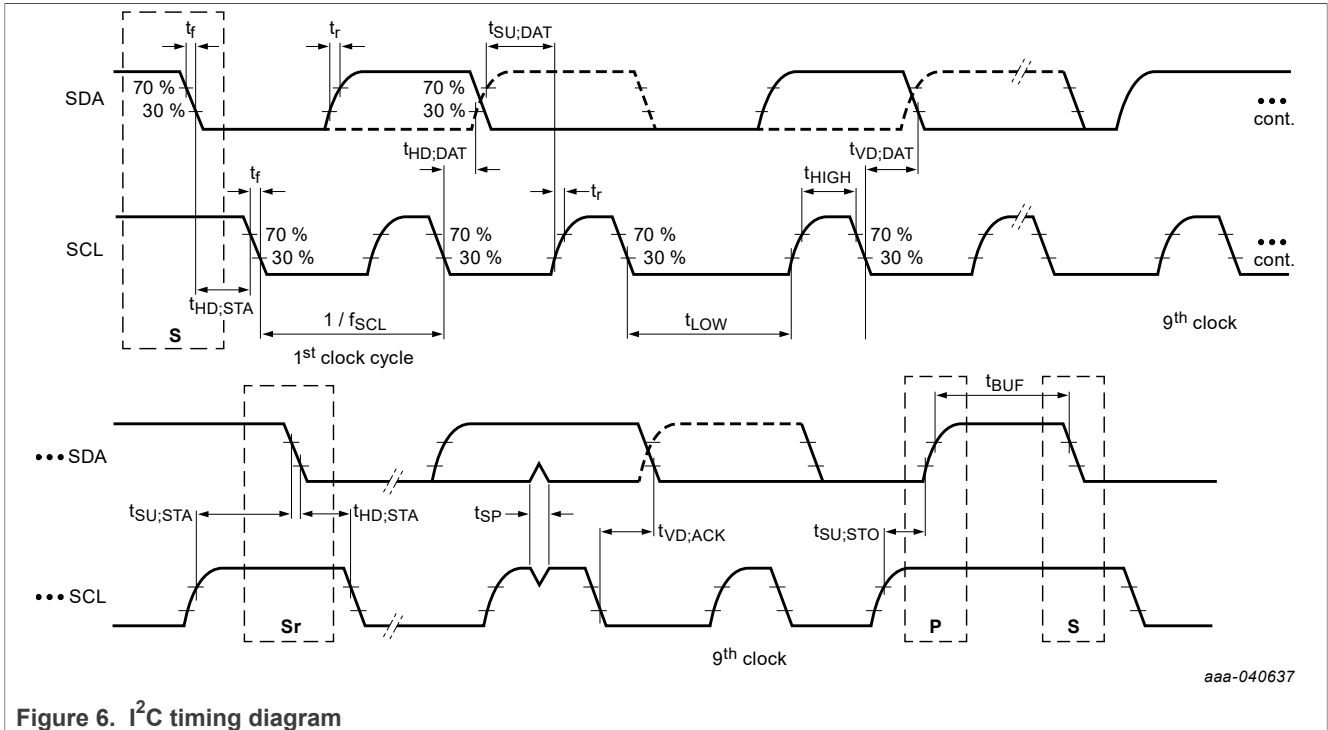

Figure 6. I²C timing diagram

7.5.3 I²C operation

The I²C transaction on the bus is initiated through a start condition (START) signal. START signal is defined as a HIGH to LOW transition on the SDA line while the SCL line is held HIGH. After START is transmitted by the host, the bus is considered busy. The next byte of data transmitted after START contains the device address in the first seven bits, and the eighth bit indicates whether the host is receiving data from the device or transmitting data to the device. When an address is sent, each device in the system compares the first seven bits after a start condition with its address. If they match, the device considers itself addressed by the host. The ninth clock pulse, following the device address byte (and each subsequent byte) is the acknowledge (ACK). The transmitter must release the SDA line during the ACK period. The receiver must then pull the data line low for it to remain stable low during the high period of the acknowledge clock period.

The number of bytes per transfer is unlimited because the internal addressing wraps after \$6D to \$00, continuing to \$6D again, then to \$00, and so forth. The wrapping applies to both write transfers and read transfers. Note that usable addresses stop at \$09, therefore a host may expect random values between \$0A to \$6D. If the host is unable to receive another complete byte of data until it has performed some other function, the host can hold the SCL line low, forcing the transmitter into a wait state. Data transfer continues only when the host is ready for another byte and releases the clock line.

A stop condition (STOP) is defined as a low to high transition on the SDA line while the SCL line is high. Data transfer is terminated by a STOP.

A host may also issue a RESTART during a data transfer. The device expects RESTARTs to randomly read from specific registers.

The bus logic of the device resets on receipt of a START, or RESTART condition. The device anticipates the sending of a device address, even if these START conditions are not positioned or follow proper format.

The device accepts the first bit of an address after each START, or RESTART condition.

The device detects when the SDA line is held low, and in such cases, releases the SDA line when the host issue no more than nine cycles of the SCL line.

The device determines the value in the NVM I²C address register. If the value is not \$00, the device uses this address during I²C transactions. If the address register is \$00, the address defaults to \$60. The reset value of the I²C address register is also \$60.

7.5.4 I²C protocol diagram

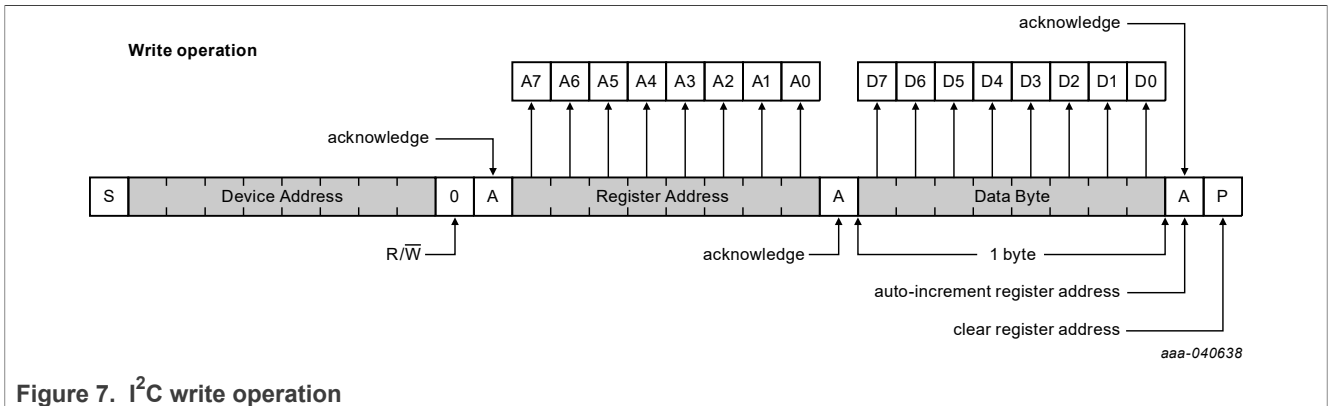

Figure 7. I²C write operation

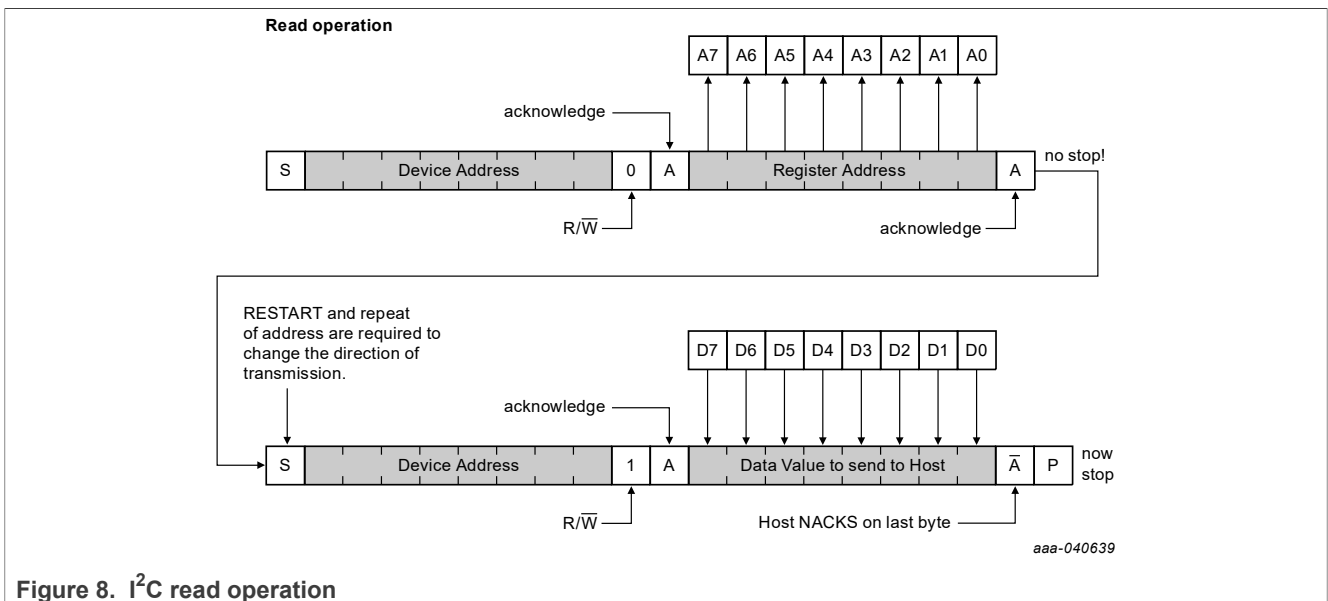

Figure 8. I²C read operation

7.6 Register map

7.6.1 Register overview

Table 9. Register map overview

| Address | Name | Description | AO or S ^[1] | Bit 7 | Bit 6 | Bit 5 | Bit 4 | Bit 3 | Bit 2 | Bit 1 | Bit 0 |
|---------|------------------------------|--|------------------------|--------|-------|-------|---------|--------|----------|----------|-------|
| \$00 | STATUS | Status reporting of modes and selections | S | OUTPUT | MDO | MDR | — | OPMODE | — | RST_STAT | OUT_B |
| \$01 | CONTROL_REG1 | Control of Operations | S | — | — | V_POL | I2C_DIS | AUTO | ONE_SHOT | — | RST |

Table 9. Register map overview...continued

| Address | Name | Description | AO or S ^[1] | Bit 7 | Bit 6 | Bit 5 | Bit 4 | Bit 3 | Bit 2 | Bit 1 | Bit 0 |
|---------|------------------------------------|--|------------------------|--------------------------|------------|-------|-------|-------|---------------|-------|-------|
| \$02 | — | Reserved | — | — | — | — | — | — | — | — | — |
| \$03 | OUT_M_REG | Report of Magnetic Strength | S | MAG_DATA [7:2] | | | | | | — | — |
| \$04 | USER_ASSERT_THRESH | User selectable output Assert threshold, N or S | AO | USER_ASSERT_THRESH [7:3] | | | | | Reserved | | |
| \$05 | USER_CLEAR_THRESH | User selectable output Clear threshold, N or S | AO | USER_CLEAR_THRESH [7:3] | | | | | Reserved | | |
| \$06 | USER_ODR | User selectable sleep sample output data rates | AO | — | — | — | — | — | USER_ODR[2:0] | | |
| \$07 | — | Reserved | — | — | — | — | — | — | — | — | — |
| \$08 | WHO_AM_I | I ² C Configured Identifier | S | WHO_AM_I [7:0] | | | | | | | |
| \$09 | I2C_ADDR | I ² C Configured Address - default after reset = \$60 | S | — | ADDR [6:0] | | | | | | |

[1] AO - Always On, S - Switched

7.6.2 Register details

7.6.2.1 Status reporting of modes and selections (STATUS) (\$00h)

Table 10. STATUS – Status reporting of modes and selections (address \$00h) bit allocation

| Bit | 7 | 6 | 5 | 4 | 3 | 2 | 1 | 0 |
|---------------|--------|-----|-----|---|--------|---|----------|-------|
| Symbol | OUTPUT | MDO | MDR | — | OPMODE | — | RST_STAT | OUT_B |
| Reset | 0 | 1 | 1 | — | 1 | — | 1 | x |
| Access | R/W | R/W | R/W | — | R/W | — | R/W | R/W |

Table 11. STATUS – Status reporting of modes and selections (address \$00h) bit descriptions

| Bit | Symbol | Access | Value | Description |
|-----|--------|--------|-------|--|
| 7 | OUTPUT | R/W | | V _{out} control block state. This bit follows the state of the OUT pin in either case of V _{POL} = 0 or 1. |
| | | | 0 | The state of VOUT is driven to low; Result of Reset. |
| | | | 1 | The state of VOUT is driven to high. |
| 6 | MDO | R/W | | Magnetic data overwrite indicates the validity of the value in register \$03. After asserting to 1, the MDO bit retains this value after the register \$03 returns to the range of \$00 to \$1F, until a read operation is performed on register \$00. The MDO reasserts if the register \$03 is again > \$1F. |
| | | | 0 | Register \$03 value is within the range \$00 to \$1F. |
| | | | 1 | Register \$03 value is >\$1F indicates out-of-range or fault; Result of reset. |
| 5 | MDR | R/W | | Magnetic data ready indicates the value in register \$03 is available for read operation. After asserting to 1, the MDR bit retains this value after the register \$03 becomes available, until a read operation is performed on register \$00. The MDR reasserts if the register \$03 is again not available. |
| | | | 0 | \$03 data available. |
| | | | 1 | \$03 data not available; Result of reset. |

Table 11. STATUS – Status reporting of modes and selections (address \$00h) bit descriptions...continued

| Bit | Symbol | Access | Value | Description |
|-----|----------|--------|-------|---|
| 3 | OPMODE | R/W | | The read-only OPMODE indicates the mode of the internal state-machine. |
| | | | 0 | Indicates VPP < VSTAND and the device in standalone mode indicating a state machine fault, since the registers are only accessible in the I ² C mode. |
| | | | 1 | Indicates VPP ≥ VSTAND and the device in I ² C user mode. |
| 1 | RST_STAT | R/W | | Reset status indicates the state-machine reset sequence. RST_STAT set to 1 as the device enters POR or soft reset. This bit is cleared to 0 upon reading the register \$00. After asserting to 1, the RST_STAT bit retains this value after the exit of POR or soft rest, until a read operation is performed on register \$00. The RST_STAT reasserts if POR or soft reset is entered. |
| | | | 0 | Reset sequence complete and read operation performed on register \$00. |
| | | | 1 | Reset sequence not complete; Result of reset. |
| 0 | OUT_B | R/W | | Output buffer indicates a latched state of the OUT pin after a transition from either Asserted to Clear or Clear to Asserted. After asserting to 1, or clearing to 0, the OUT_B bit retains this value until a read operation is performed on register \$00. This bit is intended to allow the user or tester to check for a transition while the actual OUT pin or OUTPUT bit may have changed state again between checks. |
| | | | 0 | OUT cleared on previous cycle. |
| | | | 1 | OUT asserted on previous cycle. |

7.6.2.2 Control of operations (CONTROL_Reg1) (\$01h)

Table 12. CONTROL_Reg1 – Control of operations(address \$01h) bit allocation

| Bit | 7 | 6 | 5 | 4 | 3 | 2 | 1 | 0 |
|--------|---|---|-------|---------|------|----------|---|-----|
| Symbol | — | — | V_POL | I2C_DIS | AUTO | ONE_SHOT | — | RST |
| Reset | — | — | 0 | 0 | 0 | 0 | — | 0 |
| Access | — | — | R/W | R/W | R/W | R/W | — | R/W |

Table 13. CONTROL_Reg1 – Control of operations (address \$01h) bit description

| Bit | Symbol | Access | Value | Description |
|-----|--------|--------|-------|--|
| 5 | V_POL | R/W | | V_POL provides control of the user-defined OUT pin and resultant OUT_B register bit assert / clear polarity. |
| | | | 0 | Assert = out pin high, Clear = out pin low; Result of reset. |
| | | | 1 | Assert = out pin low, Clear = out pn high. |

Table 13. CONTROL_Reg1 – Control of operations (address \$01h) bit description...continued

| Bit | Symbol | Access | Value | Description |
|-----|----------|--------|-------|---|
| 4 | I2C_DIS | R/W | | I2C_DIS provides control of the operating mode "on-the-fly" after the device exits POR or Soft Reset. I2C_DIS allows the user to force the device into standalone mode from the I ² C mode. Note: Writing 1 to I2C_DIS is a one-time-only operation. Bringing the device into I ² C mode from standalone requires a full power cycle and release of POR. Note: MAG_DATA retains its last value, and is updated upon next write to ONE_SHOT. |
| | | | 0 | Write to 0 has no effect; Read of 0 indicates I ² C mode; Result of reset. |
| | | | 1 | Write to 1 forces the device from I ² C mode to standalone mode; Read of 1 indicates a state machine fault, since the registers are only accessible in the I ² C mode. |
| 3 | AUTO | R/W | | AUTO provides control of the state machine to enter a sequential autonomous mode cycling from sleep to compare to Vout control, then back to sleep, for example. The sequence is halted when the AUTO is written to 0. |
| | | | 0 | Write to 0 halts or prevents autonomous mode; Read of 0 indicates that autonomous mode is not active; Result of reset. |
| | | | 1 | Write to 1 starts the autonomous mode; Read of 1 indicates that autonomous mode is active. |
| 2 | ONE_SHOT | R/W | | ONE_SHOT provides control of the state machine to trigger a single sequence of compare to Vout control, then halt. The bit clears upon the sequence being completed. |
| | | | 0 | Write to 0 has no effect; Read of 0 indicates One-Shot is not active; Result of reset. |
| | | | 1 | Write to 1 triggers a one-shot sequence; Read of 1 has no effect. |
| | | | | Note: The BUSY bit indicates that the sequence is underway or not completed. Note: MAG_DATA retains its last value, and is updated upon next write to ONE_SHOT. |
| 0 | RST | R/W | | RST provides I ² C access to force an internal device soft reset: |
| | | | 0 | No reset is forced. |
| | | | 1 | Internal device reset is forced. |

7.6.2.3 Magnetic strength report (OUT_M_REG) (\$03h)

Table 14. OUT_M_REG – Magnetic strength report (address \$03h) bit allocation

| Bit | 7 | 6 | 5 | 4 | 3 | 2 | 1 | 0 |
|--------|----------------|-----|-----|-----|-----|-----|----------|---|
| Symbol | MAG_DATA [7:2] | | | | | | reserved | |
| Reset | 0 | 0 | 0 | 0 | 0 | 0 | 0 | 0 |
| Access | R/W | R/W | R/W | R/W | R/W | R/W | — | — |

Table 15. OUT_M_REG – Magnetic strength report (address \$03h) bit description

| Bit | Symbol | Access | Value | Description |
|--------|----------|--------|-------|---|
| 7 to 2 | MAG_DATA | R/W | | MAG_DATA[7:2] indicates a relative magnetic field strength in units of BΔ in G/LSB. |
| | | | \$00 | 0 G; Result of reset. |
| | | | \$01 | Lowest in-range magnetic field strength. |
| | | | \$1F | Highest in-range magnetic field strength. |

7.6.2.4 User selectable output, assert threshold, N or S (USER_ASSERT_THRESH) (\$04h)

Table 16. USER_ASSERT_THRESH – User selectable output, assert threshold, N or S (address \$04h) bit allocation

| Bit | 7 | 6 | 5 | 4 | 3 | 2 | 1 | 0 |
|--------|--------------------------|-----|-----|-----|-----|----------|-----|-----|
| Symbol | USER_ASSERT_THRESH [7:3] | | | | | Reserved | | |
| Reset | 0 | 0 | 0 | 0 | 0 | — | — | — |
| Access | R/W | R/W | R/W | R/W | R/W | R/W | R/W | R/W |

Table 17. USER_ASSERT_THRESH – User selectable output, assert threshold, N or S (address \$04h) bit description

| Bit | Symbol | Access | Value | Description |
|--------|--------------------|--------|-------|---|
| 7 to 3 | USER_ASSERT_THRESH | R/W | | In I ² C mode, USER_ASSERT_THRESH[7:3] provides the capability for the user to override the fixed threshold controlling the output assert condition, in units of BΔ in G/LSB. Note: Hysteresis is controlled by appropriate user settings for both USER_ASSERT_THRESH and USER_CLEAR_THRESH registers. |
| | | | \$00 | 0 G; Result of reset. |
| | | | \$01 | Lowest in-range magnetic field to assert the output. |
| | | | \$1F | Highest in-range magnetic field to assert the output. |

7.6.2.5 User selectable output, clear threshold, N or S (USER_CLEAR_THRESH) (\$05h)

Table 18. USER_CLEAR_THRESH – User selectable output, clear threshold, N or S (address \$05h) bit allocation

| Bit | 7 | 6 | 5 | 4 | 3 | 2 | 1 | 0 |
|--------|-------------------------|-----|-----|-----|-----|----------|-----|-----|
| Symbol | USER_CLEAR_THRESH [7:3] | | | | | Reserved | | |
| Reset | 0 | 0 | 0 | 0 | 0 | — | — | — |
| Access | R/W | R/W | R/W | R/W | R/W | R/W | R/W | R/W |

Table 19. USER_CLEAR_THRESH – User selectable output, clear threshold, N or S (address \$05h) bit description

| Bit | Symbol | Access | Value | Description |
|--------|-------------------|--------|-------|---|
| 7 to 3 | USER_CLEAR_THRESH | R/W | | In I ² C mode, USER_CLEAR_THRESH[7:3] provides the capability for the user to override the fixed threshold controlling the output clear condition, in units of BΔ in G/LSB. Note: Hysteresis is controlled by appropriate user settings for both USER_ASSERT_THRESH and USER_CLEAR_THRESH registers. |
| | | | \$00 | 0 G; Result of reset. |
| | | | \$01 | Lowest in-range magnetic field to clear the output. |
| | | | \$1F | Highest in-range magnetic field to clear the output. |

7.6.2.6 User selectable sleep sample output data rates (USER_ODR) (\$06h)

Table 20. USER_ODR – User selectable sleep sample output data rates (address \$06h) bit allocation

| Bit | 7 | 6 | 5 | 4 | 3 | 2 | 1 | 0 |
|--------|---|---|---|---|---|---------------|-----|-----|
| Symbol | — | — | — | — | — | USER_ODR[2:0] | | |
| Reset | — | — | — | — | — | 0 | 0 | 0 |
| Access | — | — | — | — | — | R/W | R/W | R/W |

Table 21. USER_ODR – User selectable sleep sample output data rates (address \$06h) bit description

| Bit | Symbol | Access | Value | Description |
|--------|----------------------|--------|-------|---|
| 2 to 0 | USER_ODR | R/W | | In I ² C mode, USER_ODR[2:0] provides the capability for the user to override the fixed sample rate controlling the sleep-compare-Vout cycle time. |
| | | | 0 0 0 | Low sample rate selected. |
| | | | 0 0 1 | 5 x Low sample rate selected. |
| | | | 0 1 0 | Medium sample rate selected. |
| | | | 0 1 1 | 5 x Medium sample rate selected. |
| | | | 1 0 0 | High sample rate selected. |
| | | | 1 0 1 | 5 x High sample rate selected. |
| | | | 1 1 0 | 10 x High sample rate selected. |
| 1 1 1 | Configuration error. | | | |

7.6.2.7 I²C configured identifier (WHO_AM_I) (\$08h)

Table 22. WHO_AM_I - I²C configured identifier (address \$08h) bit allocation

| Bit | 7 | 6 | 5 | 4 | 3 | 2 | 1 | 0 |
|--------|----------------|-----|-----|-----|-----|-----|-----|-----|
| Symbol | WHO_AM_I [7:0] | | | | | | | |
| Reset | 0 | 0 | 0 | 0 | 0 | 0 | 0 | 1 |
| Access | R/W | R/W | R/W | R/W | R/W | R/W | R/W | R/W |

Table 23. WHO_AM_I - I²C configured identifier (address \$08h) bit description

| Bit | Symbol | Access | Value | Description |
|--------|----------|--------|--------------|---|
| 7 to 0 | WHO_AM_I | R/W | | WHO_AM_I[7:0] provides the device identification register. The value is programmed in the NVM at final test. Each variation has its own unique device ID. |
| | | | \$00 | WHO_AM_I error condition. |
| | | | \$01 | Generic open market default value. |
| | | | \$02 to \$FE | Customer defined unique values. |
| | | | \$FF | WHO_AM_I not programmed. |

7.6.2.8 I²C configured identifier (I2C_ADDR) (\$09h)

Table 24. I2C_ADDR - I²C configured identifier (address \$09h) bit allocation

| Bit | 7 | 6 | 5 | 4 | 3 | 2 | 1 | 0 |
|--------|---|----------------|-----|-----|-----|-----|-----|-----|
| Symbol | — | I2C_ADDR [6:0] | | | | | | |
| Reset | — | 1 | 1 | 0 | 0 | 0 | 0 | 0 |
| Access | — | R/W | R/W | R/W | R/W | R/W | R/W | R/W |

Table 25. I2C_ADDR - I²C configured identifier (address \$09h) bit description

| Bit | Symbol | Access | Value | Description |
|--------|----------|--------|-------|---|
| 6 to 0 | I2C_ADDR | R/W | | I2C_ADDR[6:0] is register mapped and loaded by default value \$60 at boot time. After that, users may write any non-zero value to it. This non-zero value is used until the device is reset. If the device is reset, the same default value of \$60 is reloaded and used again. |
| | | | \$60 | \$60 = default loaded at exit of reset. |
| | | | \$00 | \$00 = lowest address value. |
| | | | \$7F | \$7F = highest address value. |

8 Limiting values

Table 26. Limiting values

| Symbol | Description | Condition | Min | Typ | Max | Unit |
|--------------------|---|---|-----------------------|-----|------------------------|-----------|
| B _G | Magnetic field | T _A Min ≤ T _A ≤ T _A Max, V _{DD} Min ≤ V _{DD} ≤ V _{DD} Max | — | — | Not limited | G (Gauss) |
| V _{SUP} | V _{DD} to V _{SS} range | T _A Min ≤ T _A ≤ T _A Max, V _{DD} Min ≤ V _{DD} ≤ V _{DD} Max | -0.3 | — | 3.6 | V |
| V _{IO} | IO pin voltage, each pin vs V _{DD} / V _{SS} | T _A Min ≤ T _A ≤ T _A Max | V _{SS} - 0.3 | — | V _{SUP} + 0.3 | V |
| I _{IO} | IO pin current, each pin vs V _{DD} / V _{SS} | T _A Min ≤ T _A ≤ T _A Max, V _{DD} Min ≤ V _{DD} ≤ V _{DD} Max | -10 | — | 10 | mA |
| I _{SUBIO} | Substrate current injection, all IO pins, current from pin to V _{SS} - 0.3 V | T _A Min ≤ T _A ≤ T _A Max, V _{DD} Min ≤ V _{DD} ≤ V _{DD} Max | — | 100 | — | mA |

Table 26. Limiting values...continued

| Symbol | Description | Condition | Min | Typ | Max | Unit |
|--------------|--|--|-------|-----|------|------|
| I_{LATCH} | Latch-up current, current to/from pin to $V_{DD}/V_{DDA} + 0.3$ V | $T_A \text{ Min} \leq T_A \leq T_A \text{ Max}$, $V_{DD} \text{ Min} \leq V_{DD} \leq V_{DD} \text{ Max}$ | -100 | — | 100 | mA |
| ESD_{HBM} | Electrostatic discharge, Human Body Model (HBM) all pins | $T_A = 25$ °C, $V_{DD} = 1.5$ V | -2000 | — | 2000 | V |
| ESD_{CDM} | Electrostatic discharge, Charged Device Model (CDM) all pins | $T_A = 25$ °C, $V_{DD} = 1.5$ V | -500 | — | 500 | V |
| EOS_{EMIR} | Conducted immunity DPI, until OUT unintentionally changes state or I ² C corruption | $T_A = 25$ °C, $V_{DD} = 1.5$ V | — | 30 | — | dBm |
| T_{STG} | Unpowered storage temperature range | — | -40 | — | 150 | °C |

9 Recommended operating conditions

Table 27. Operating conditions

| Symbol | Description | Condition | Min | Typ | Max | Unit |
|--------------------|--|--|---------------------|---------------------|---------------------|------|
| Transitions | | | | | | |
| t_{OP} | Power-on initialization | From $V_{DD} > 1.2$ V to Operation Ready; 25 °C and 1.5 V. | — | 4.8 | 5.1 | ms |
| t_{BOC-A} | Cleared state to Asserted state phase delay | $T_A \text{ Min} \leq T_A \leq T_A \text{ Max}$, $V_{DD} \text{ Min} \leq V_{DD} \leq V_{DD} \text{ Max}$ | — | 100 | — | μs |
| Voltages | | | | | | |
| V_{DD} | Operating voltage range where Min = $V_{DD} \text{ Min}$, Typ = 1.5 V, Max = $V_{DD} \text{ Max}$ | $T_A \text{ Min} \leq T_A \leq T_A \text{ Max}$ | 1.2 | 1.5 | V_{SUP} | V |
| V_{STAND} | MODE pin voltage - Standalone mode | $T_A = 25$ °C, $V_{DD} = 1.5$ V | $V_{SS} - 0.3$ | — | $0.3 \times V_{DD}$ | V |
| V_{STAND} | Mode pin voltage - I ² C mode | $T_A = 25$ °C, $V_{DD} = 1.5$ V | $0.7 \times V_{DD}$ | — | $V_{DD} + 0.3$ | V |
| V_{TH} | TH-SDA pin - Standalone mode, Low threshold | $T_A \text{ Min} \leq T_A \leq T_A \text{ Max}$, $V_{DD} \text{ Min} \leq V_{DD} \leq V_{DD} \text{ Max}$ | $0.4 \times V_{DD}$ | $0.5 \times V_{DD}$ | $0.6 \times V_{DD}$ | V |
| V_{TH} | TH-SDA pin - Standalone mode, Medium threshold | $T_A \text{ Min} \leq T_A \leq T_A \text{ Max}$, $V_{DD} \text{ Min} \leq V_{DD} \leq V_{DD} \text{ Max}$ | — | — | $0.3 \times V_{DD}$ | V |
| V_{TH} | TH-SDA pin - Standalone mode, High threshold | $T_A \text{ Min} \leq T_A \leq T_A \text{ Max}$, $V_{DD} \text{ Min} \leq V_{DD} \leq V_{DD} \text{ Max}$ | $0.7 \times V_{DD}$ | — | — | V |
| V_{ODR} | ODR-SCL pin - Standalone mode, Low sample rate | $T_A \text{ Min} \leq T_A \leq T_A \text{ Max}$, $V_{DD} \text{ Min} \leq V_{DD} \leq V_{DD} \text{ Max}$ | $0.4 \times V_{DD}$ | $0.5 \times V_{DD}$ | $0.6 \times V_{DD}$ | V |
| V_{ODR} | ODR-SCL pin - Standalone mode, Medium sample rate | $T_A \text{ Min} \leq T_A \leq T_A \text{ Max}$, $V_{DD} \text{ Min} \leq V_{DD} \leq V_{DD} \text{ Max}$ | — | — | $0.3 \times V_{DD}$ | V |
| V_{ODR} | ODR-SCL pin - Standalone mode, High sample rate | $T_A \text{ Min} \leq T_A \leq T_A \text{ Max}$, $V_{DD} \text{ Min} \leq V_{DD} \leq V_{DD} \text{ Max}$ | $0.7 \times V_{DD}$ | — | — | V |

Table 27. Operating conditions...continued

| Symbol | Description | Condition | Min | Typ | Max | Unit |
|---------------------|---|--|--------|-----|-----|------|
| Temperatures | | | | | | |
| T_A | Operating temperature range where Min = T_A Min, Typ = 25 °C, Max = T_A Max | $V_{DD} \text{ Min} \leq V_{DD} \leq V_{DD} \text{ Max}$ | -40 °C | 25 | +85 | °C |

10 Characteristics

10.1 Supply currents

Table 28. Supply currents

| Symbol | Description | Condition | Min | Typ | Max | Unit |
|----------------------|---|---|-----|-------|-----|------|
| $I_{DD\text{-L}ODR}$ | Supply current, Low ODR | Typical value is calculated by a time-weighted average of the consumption during the measurement and sleeping phases while in the Low ODR stand-alone mode. | — | 47.5 | 187 | nA |
| $I_{DD\text{-M}ODR}$ | Supply current, Medium ODR | Typical value is calculated by a time-weighted average of the consumption during the measurement and sleeping phases while in the Medium ODR stand-alone mode | — | 72.2 | 234 | nA |
| $I_{DD\text{-H}ODR}$ | Supply current, High ODR | Typical value is calculated by a time-weighted average of the consumption during the measurement and sleeping phases while in the High ODR stand-alone mode. | — | 319.6 | 760 | nA |
| $I_{DD\text{-S}}$ | Supply current, Sleep mode | Typ = 25 °C, $V_{DD} = 1.5 \text{ V Max} = T_A \text{ Min to } T_A \text{ Max}$ and $V_{DD} \text{ Min to } V_{DD} \text{ Max}$ | — | 42 | 300 | nA |
| $I_{DD\text{-M}}$ | Supply current, measurement | Typ = 25 °C, $V_{DD} = 1.5 \text{ V Max} = T_A \text{ Min to } T_A \text{ Max}$ and $V_{DD} \text{ Min to } V_{DD} \text{ Max}$ | — | 580 | 650 | μA |
| $I_{DD\text{-2}}$ | Supply current, I ² C command/response | Typ = 25 °C, 1.5 V, Max = $T_A \text{ Min} \leq T_A \leq T_A \text{ Max}$, $V_{DD} \text{ Min} \leq V_{DD} \leq V_{DD} \text{ Max}$ | — | 35 | 45 | μA |

10.2 Clocks and rates

Table 29. Clocks and rates

| Symbol | Description | Condition | Min | Typ | Max | Unit |
|-----------|---------------------------|--|-----|-----|-----|------|
| f_{LFO} | Low frequency oscillator | $T_A \text{ Min} \leq T_A \leq T_A \text{ Max}$, $V_{DD} \text{ Min} \leq V_{DD} \leq V_{DD} \text{ Max}$ | 2.8 | 3.2 | 3.5 | kHz |
| f_{HFO} | High frequency oscillator | $T_A \text{ Min} \leq T_A \leq T_A \text{ Max}$, $V_{DD} \text{ Min} \leq V_{DD} \leq V_{DD} \text{ Max}$ | 1.7 | 2 | 2.3 | MHz |

Table 29. Clocks and rates...continued

| Symbol | Description | Condition | Min | Typ | Max | Unit |
|--------------------|------------------------------|---|-----|-----|-----|------|
| f _{SCL} | I ² C input clock | T _A Min ≤ T _A ≤ T _A Max, V _{DD} Min ≤ V _{DD} ≤ V _{DD} Max | — | — | 1 | MHz |
| f _{ODR-H} | Sample rate - High | T _A Min ≤ T _A ≤ T _A Max, V _{DD} Min ≤ V _{DD} ≤ V _{DD} Max | — | 10 | — | Hz |
| f _{ODR-M} | Sample rate - Medium | T _A Min ≤ T _A ≤ T _A Max, V _{DD} Min ≤ V _{DD} ≤ V _{DD} Max | — | 1 | — | Hz |
| f _{ODR-L} | Sample rate - Low | T _A Min ≤ T _A ≤ T _A Max, V _{DD} Min ≤ V _{DD} ≤ V _{DD} Max | — | 0.1 | — | Hz |

10.3 I²C pin thresholds

Table 30. I²C pin thresholds

| Symbol | Description | Condition | Min | Typ | Max | Unit |
|------------------|-----------------------------------|--|-----------------------|-----|-----------------------|------|
| V _{IH} | Digital high-level input voltage | T _A Min ≤ T _A ≤ T _A Max, V _{DD} Min ≤ V _{DD} ≤ V _{DD} Max at I _{IH} max | 0.7 x V _{DD} | — | V _{DD} + 0.3 | V |
| V _{IL} | Digital low-level input voltage | T _A Min ≤ T _A ≤ T _A Max, V _{DD} Min ≤ V _{DD} ≤ V _{DD} Max at I _{IL} Max | V _{SS} - 0.3 | — | 0.3 x V _{DD} | V |
| V _{OH} | Digital high-level output voltage | T _A Min ≤ T _A ≤ T _A Max, V _{DD} Min ≤ V _{DD} ≤ V _{DD} Max at I _{OH} Max | V _{DD} - 0.3 | — | — | V |
| V _{OL} | Digital low-level output voltage | T _A Min ≤ T _A ≤ T _A Max, V _{DD} Min ≤ V _{DD} ≤ V _{DD} Max at I _{OL} Max | — | — | V _{SS} + 0.3 | V |
| I _{pin} | Digital pin current | T _A = 25 °C, V _{DD} = 1.5 V | — | — | ±10 | mA |

10.4 Serial data timing characteristics

Table 31. Serial data timing characteristics

| Symbol | Description | Condition | Min | Typ | Max | Unit |
|-------------------------------------|--|---|-----|-----|-----|------|
| C _B | Board capacitive load SDA, SCL | T _A Min ≤ T _A ≤ T _A Max, V _{DD} Min ≤ V _{DD} ≤ V _{DD} Max | — | — | 1 | μF |
| t _{BUF} | Bus free time, between stop and start | T _A Min ≤ T _A ≤ T _A Max, V _{DD} Min ≤ V _{DD} ≤ V _{DD} Max | 4.7 | — | — | μs |
| t _{HD} to t _{STA} | Restart hold, after this period the first clock may be generated | T _A Min ≤ T _A ≤ T _A Max, V _{DD} Min ≤ V _{DD} ≤ V _{DD} Max | 4.0 | — | — | μs |
| t _{SU} to t _{STA} | Restart setup | T _A Min ≤ T _A ≤ T _A Max, V _{DD} Min ≤ V _{DD} ≤ V _{DD} Max | 4.7 | — | — | μs |
| t _{SU} to t _{STO} | Stop setup | T _A Min ≤ T _A ≤ T _A Max, V _{DD} Min ≤ V _{DD} ≤ V _{DD} Max | 4.0 | — | — | μs |
| t _{HD} to t _{DAT} | SDA hold | T _A Min ≤ T _A ≤ T _A Max, V _{DD} Min ≤ V _{DD} ≤ V _{DD} Max | 300 | — | — | ns |
| t _{SU} to t _{DAT} | SDA setup | T _A Min ≤ T _A ≤ T _A Max, V _{DD} Min ≤ V _{DD} ≤ V _{DD} Max | 250 | — | — | ns |
| t _{LOW} | SCL low | T _A Min ≤ T _A ≤ T _A Max, V _{DD} Min ≤ V _{DD} ≤ V _{DD} Max | 4.7 | — | — | μs |

Table 31. Serial data timing characteristics...continued

| Symbol | Description | Condition | Min | Typ | Max | Unit |
|-------------------|------------------|---|-----|-----|------|------|
| t _{HIGH} | SCL high | T _A Min ≤ T _A ≤ T _A Max, V _{DD} Min ≤ V _{DD} ≤ V _{DD} Max | 4.0 | — | — | μs |
| t _r | SDA and SCL rise | T _A Min ≤ T _A ≤ T _A Max, V _{DD} Min ≤ V _{DD} ≤ V _{DD} Max | — | — | 1000 | ns |
| t _f | SDA and SCL fall | T _A Min ≤ T _A ≤ T _A Max, V _{DD} Min ≤ V _{DD} ≤ V _{DD} Max | — | — | 300 | ns |

10.5 Magnetic field characteristics

Table 32. Magnetic field characteristics

| Symbol | Description | Condition | Min | Typ | Max | Unit |
|--------------------------|--------------------------------------|---|-----|------|------|-------|
| Transfer Function | | | | | | |
| BΔ | Sensitivity | T _A = 25 °C, V _{DD} = 1.5 V | — | 1.75 | — | G/LSB |
| B _{off} | Offset | T _A = 25 °C, V _{DD} = 1.5 V | — | 0 | — | G |
| B _{hyst} | Assert - Clear hysteresis | T _A = 25 °C, V _{DD} = 1.5 V | 20 | — | — | G |
| BOC _{x-L} | OUT pin transition, Low threshold | T _A = 25 °C, V _{DD} = 1.5 v | — | — | ±100 | G |
| BOC _{x-M} | OUT pin transition, Medium threshold | T _A = 25 °C, V _{DD} = 1.5 v | — | — | ±160 | G |
| BOC _{x-H} | OUT pin transition, High threshold | T _A = 25 °C, V _{DD} = 1.5 v | — | — | ±230 | G |

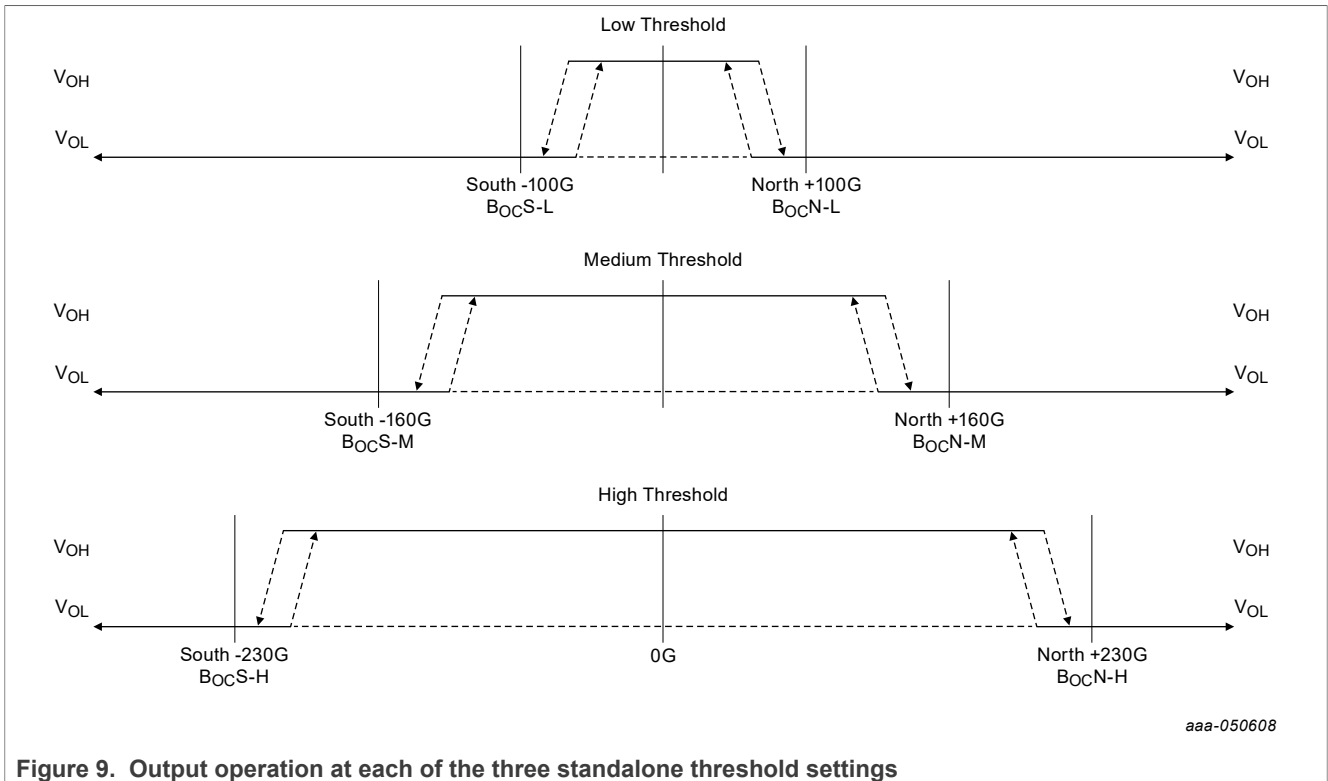

Figure 9. Output operation at each of the three standalone threshold settings

10.6 I²C user mode, output assertion

Table 33. I²C user mode, recommended lowest USER_ASSERT_THRESH [7:3] output assertion

| Symbol | Description | Condition | Min | Typ | Max | Unit |
|----------------------|---|---|-----|--------|-----|------|
| B _{OA} -I2C | Output assertion, magnetic field collapsing | T _A Min ≤ T _A ≤ T _A Max, V _{DD} Min ≤ V _{DD} ≤ V _{DD} Max | — | < 0x10 | — | hex |

10.7 I²C user mode, output clear

Table 34. I²C user mode, recommended highest USER_CLEAR_THRESH [7:3] output clear

| Symbol | Description | Condition | Min | Typ | Max | Unit |
|----------------------|---|---|-----|--------|-----|------|
| B _{OC} -I2C | Output clear, magnetic field increasing | T _A Min ≤ T _A ≤ T _A Max, V _{DD} Min ≤ V _{DD} ≤ V _{DD} Max | — | > 0xF0 | — | hex |

11 Application information

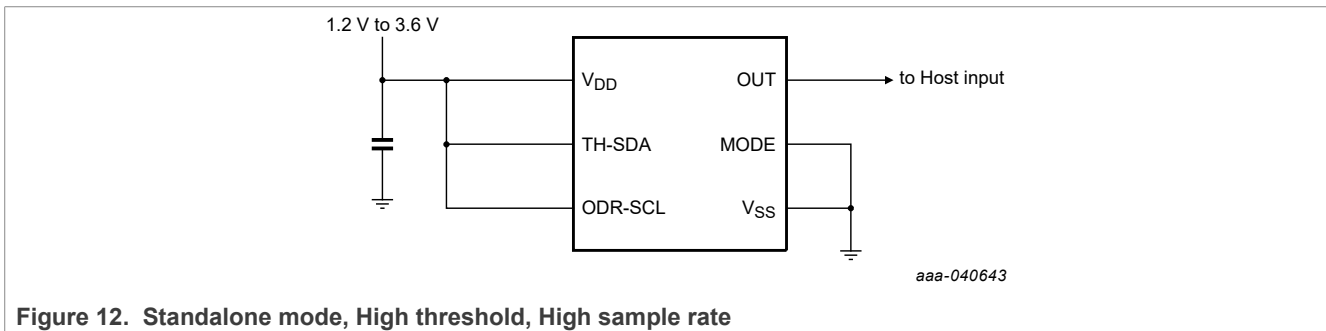
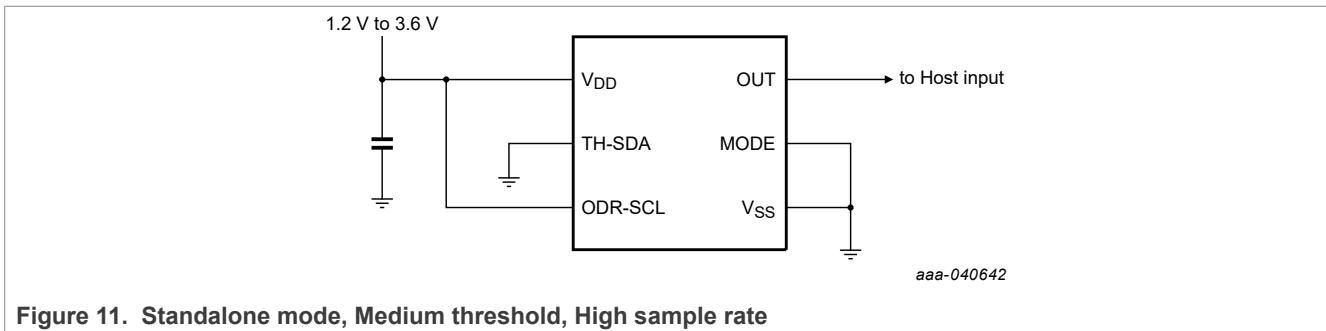
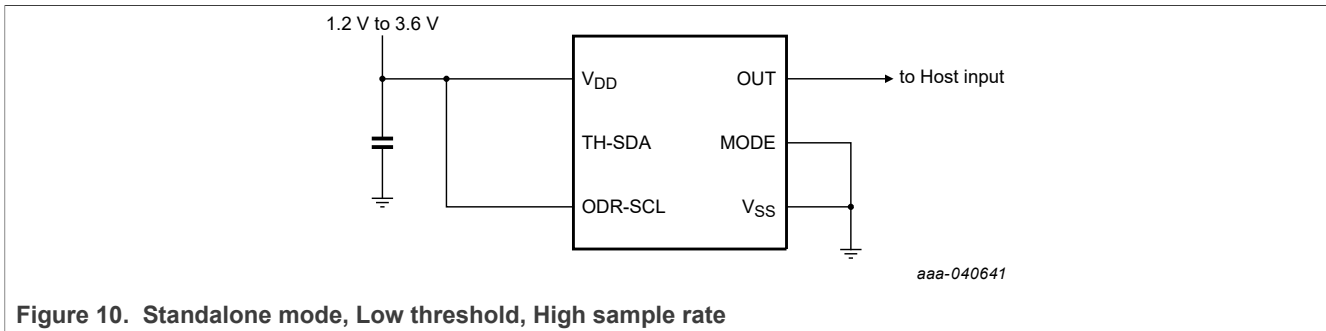

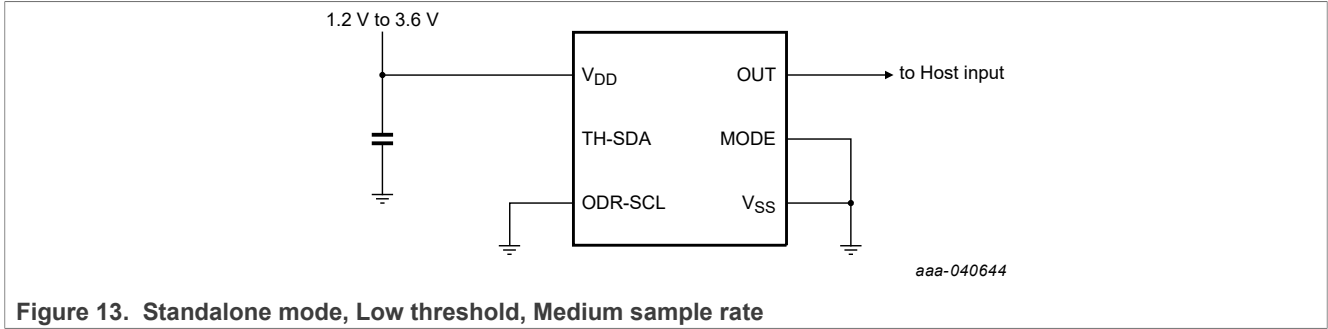

Figure 13. Standalone mode, Low threshold, Medium sample rate

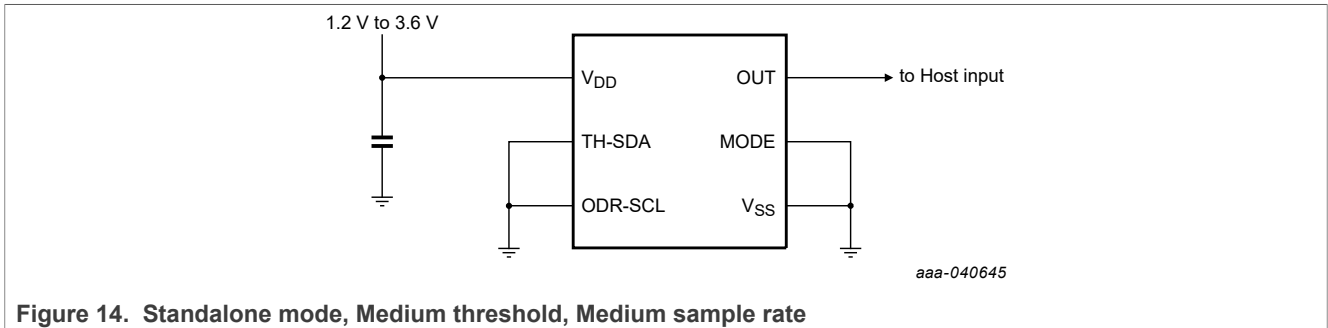

Figure 14. Standalone mode, Medium threshold, Medium sample rate

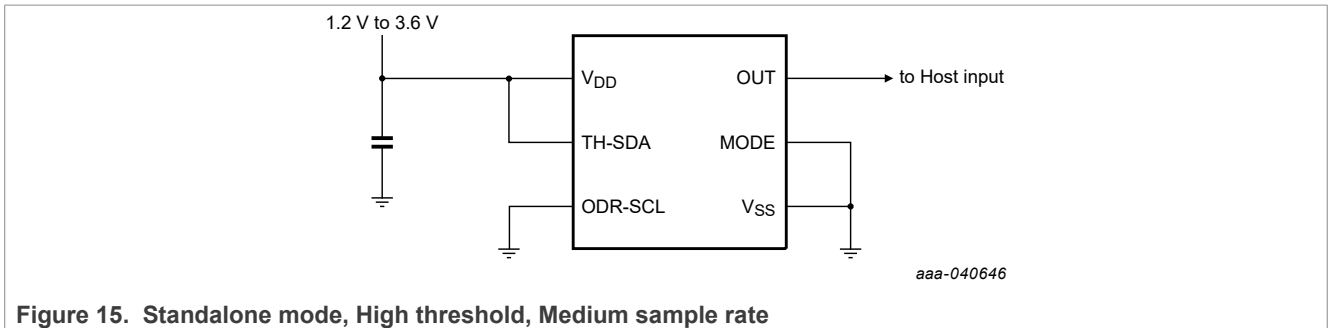

Figure 15. Standalone mode, High threshold, Medium sample rate

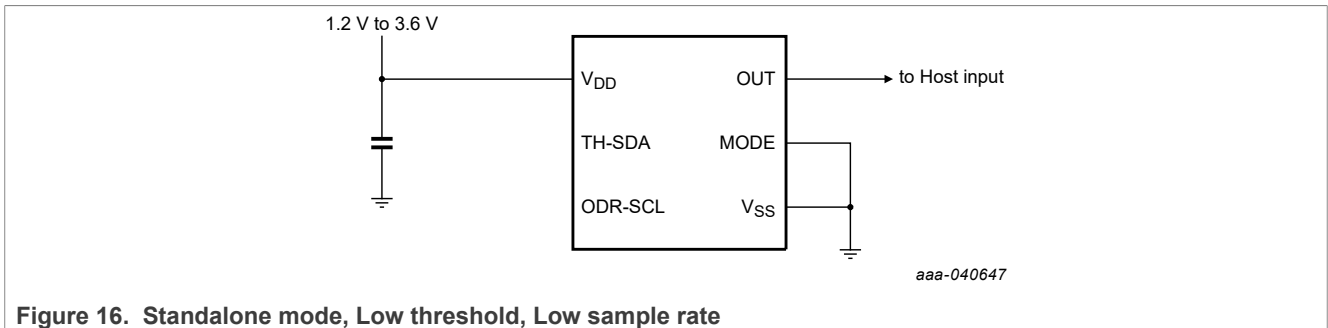

Figure 16. Standalone mode, Low threshold, Low sample rate

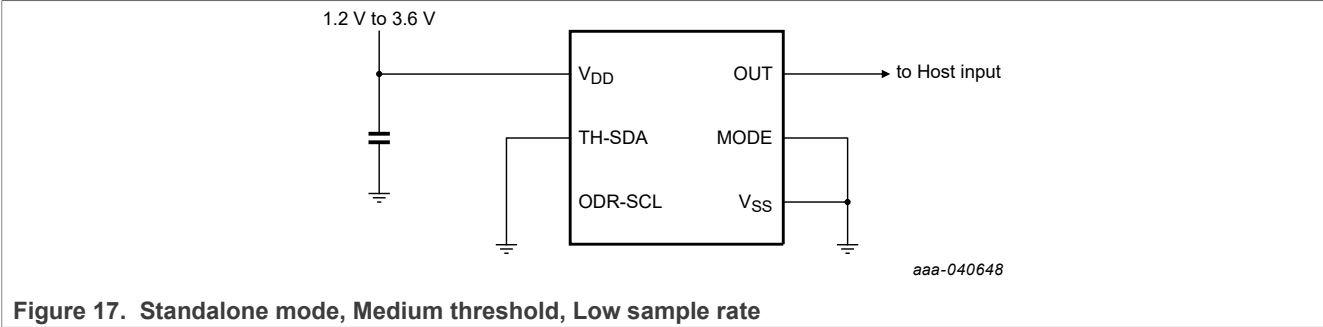

Figure 17. Standalone mode, Medium threshold, Low sample rate

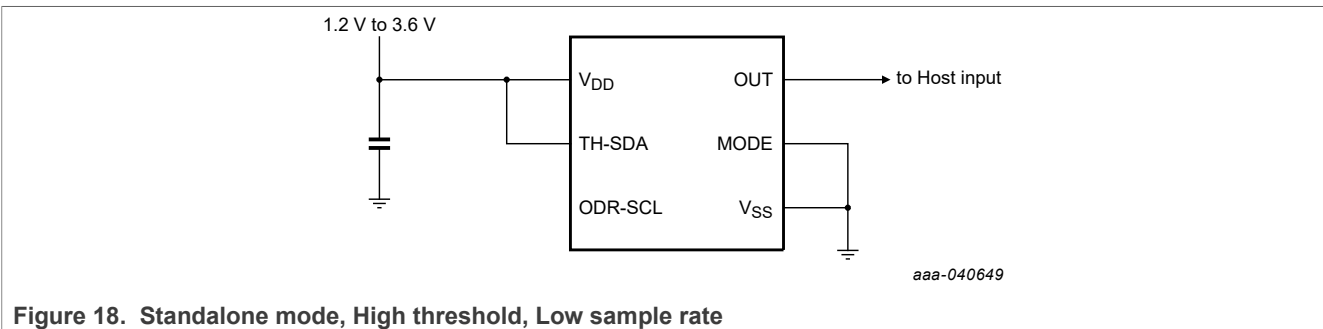

Figure 18. Standalone mode, High threshold, Low sample rate

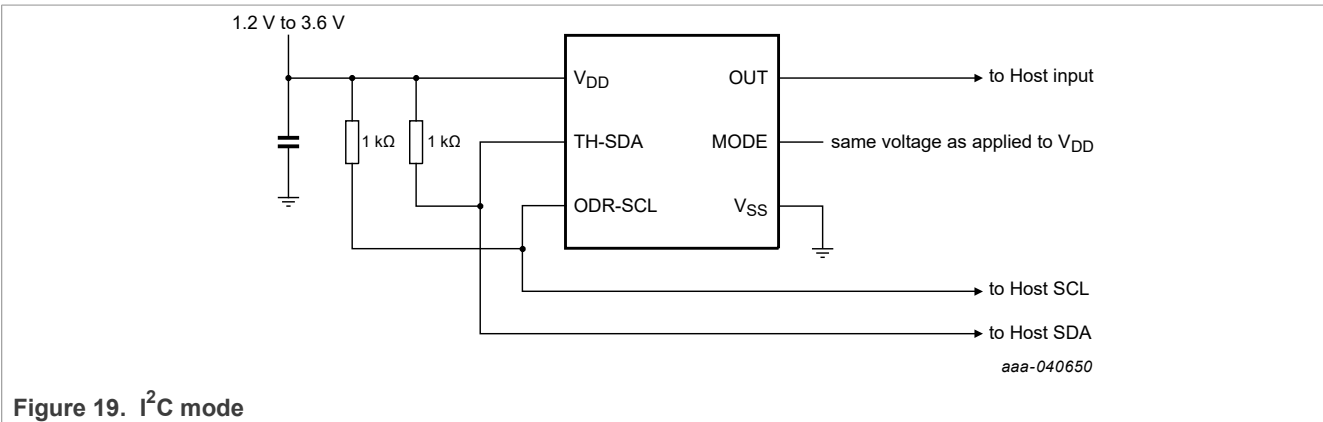

Figure 19. I²C mode

12 Package outline

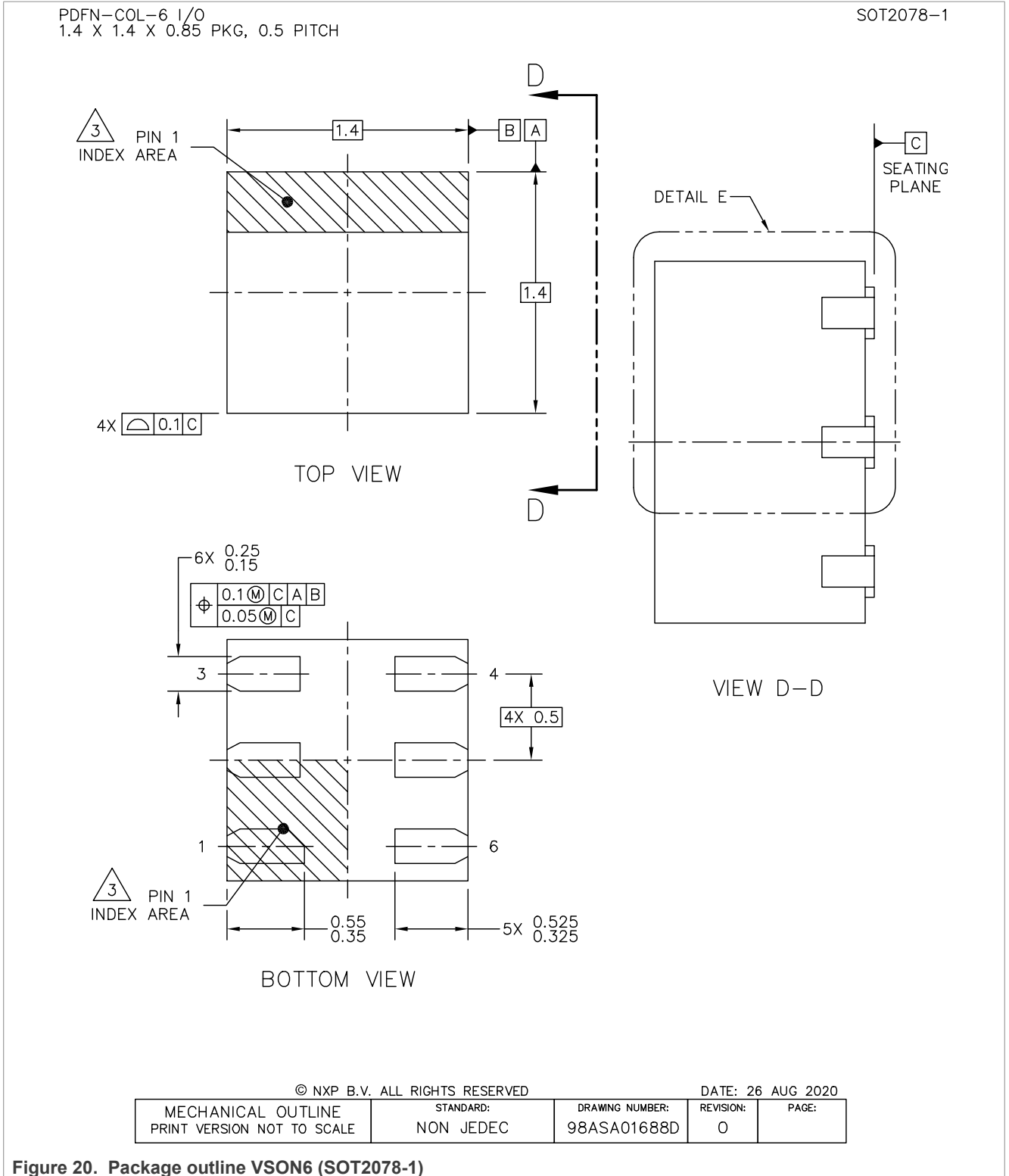
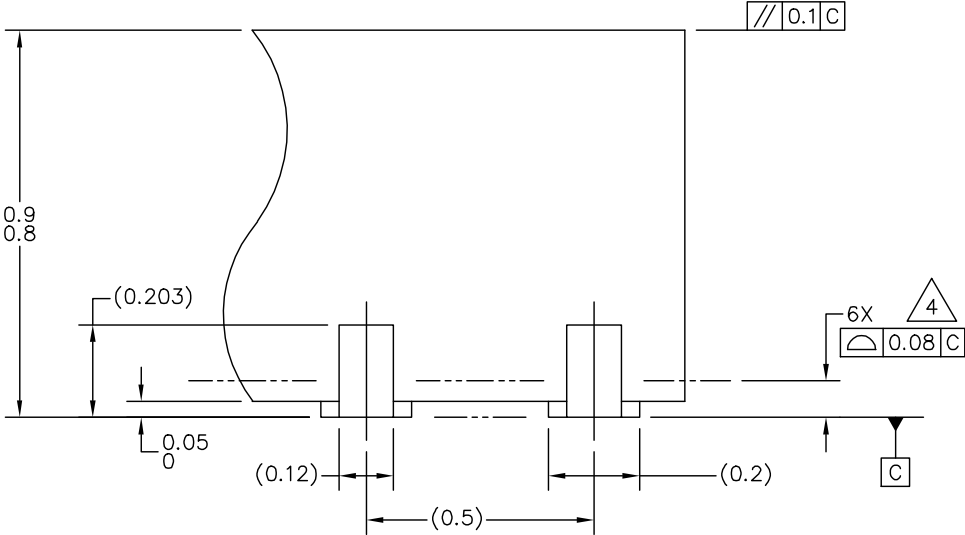

Figure 20. Package outline VSON6 (SOT2078-1)

PDFN-COL-6 I/O
1.4 X 1.4 X 0.85 PKG, 0.5 PITCH

SOT2078-1



DETAIL E
VIEW ROTATED 90°CW

© NXP B.V. ALL RIGHTS RESERVED

DATE: 26 AUG 2020

| | | | | |
|--|------------------------|--------------------------------|----------------|-------|
| MECHANICAL OUTLINE PRINT VERSION NOT TO SCALE | STANDARD: NON JEDEC | DRAWING NUMBER: 98ASA01688D | REVISION: 0 | PAGE: |
|--|------------------------|--------------------------------|----------------|-------|

Figure 21. Package outline detail of VSON6 (SOT2078-1)

PDFN-COL-6 I/O
1.4 X 1.4 X 0.85 PKG, 0.5 PITCH

SOT2078-1

NOTES:

1. ALL DIMENSIONS ARE IN MILLIMETERS.
2. DIMENSIONING AND TOLERANCING PER ASME Y14.5M-1994.
3. PIN 1 FEATURE SHAPE, SIZE AND LOCATION MAY VARY.
4. COPLANARITY APPLIES TO LEADS.
5. MIN. METAL GAP SHOULD BE 0.15 MM.

© NXP B.V. ALL RIGHTS RESERVED

DATE: 26 AUG 2020

| | | | | |
|--|------------------------|--------------------------------|----------------|-------|
| MECHANICAL OUTLINE PRINT VERSION NOT TO SCALE | STANDARD: NON JEDEC | DRAWING NUMBER: 98ASA01688D | REVISION: 0 | PAGE: |
|--|------------------------|--------------------------------|----------------|-------|

Figure 22. Package outline note VSON6 (SOT2078-1)

13 Soldering information

PDFN-COL-6 I/O
1.4 X 1.4 X 0.85 PKG, 0.5 PITCH

SOT2078-1

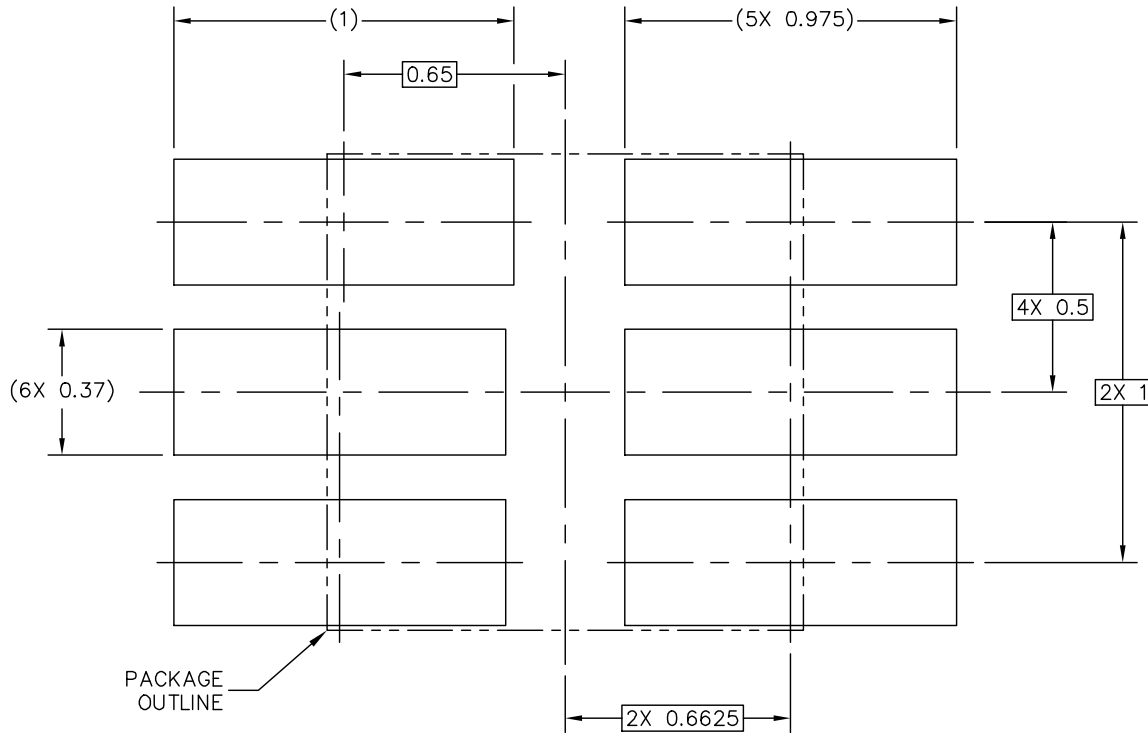

PCB DESIGN GUIDELINES – SOLDER MASK OPENING PATTERN

THIS SHEET SERVES ONLY AS A GUIDELINE TO HELP DEVELOP A USER SPECIFIC SOLUTION. DEVELOPMENT EFFORT WILL STILL BE REQUIRED BY END USERS TO OPTIMIZE PCB MOUNTING PROCESSES AND BOARD DESIGN IN ORDER TO MEET INDIVIDUAL/SPECIFIC REQUIREMENTS.

© NXP B.V. ALL RIGHTS RESERVED

DATE: 26 AUG 2020

| | | | | |
|--|------------------------|--------------------------------|----------------|-------|
| MECHANICAL OUTLINE PRINT VERSION NOT TO SCALE | STANDARD: NON JEDEC | DRAWING NUMBER: 98ASA01688D | REVISION: 0 | PAGE: |
|--|------------------------|--------------------------------|----------------|-------|

Figure 23. Reflow soldering footprint part 1 for VSON6 (SOT2078-1)

PDFN-COL-6 I/O
1.4 X 1.4 X 0.85 PKG, 0.5 PITCH

SOT2078-1

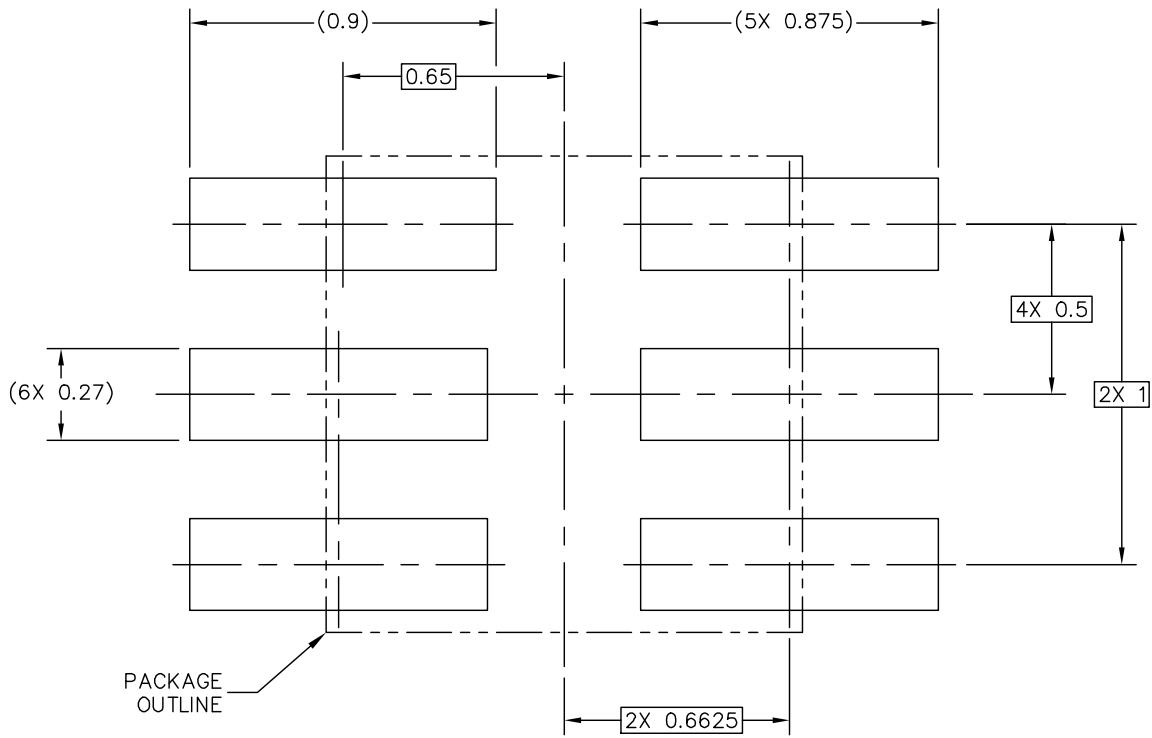

PCB DESIGN GUIDELINES – I/O PADS AND SOLDERABLE AREA

THIS SHEET SERVES ONLY AS A GUIDELINE TO HELP DEVELOP A USER SPECIFIC SOLUTION. DEVELOPMENT EFFORT WILL STILL BE REQUIRED BY END USERS TO OPTIMIZE PCB MOUNTING PROCESSES AND BOARD DESIGN IN ORDER TO MEET INDIVIDUAL/SPECIFIC REQUIREMENTS.

© NXP B.V. ALL RIGHTS RESERVED

DATE: 26 AUG 2020

| | | | | |
|--|------------------------|--------------------------------|----------------|-------|
| MECHANICAL OUTLINE PRINT VERSION NOT TO SCALE | STANDARD: NON JEDEC | DRAWING NUMBER: 98ASA01688D | REVISION: 0 | PAGE: |
|--|------------------------|--------------------------------|----------------|-------|

Figure 24. Reflow soldering footprint part 2 for VSON6 (SOT2078-1)

PDFN-COL-6 I/O
1.4 X 1.4 X 0.85 PKG, 0.5 PITCH

SOT2078-1

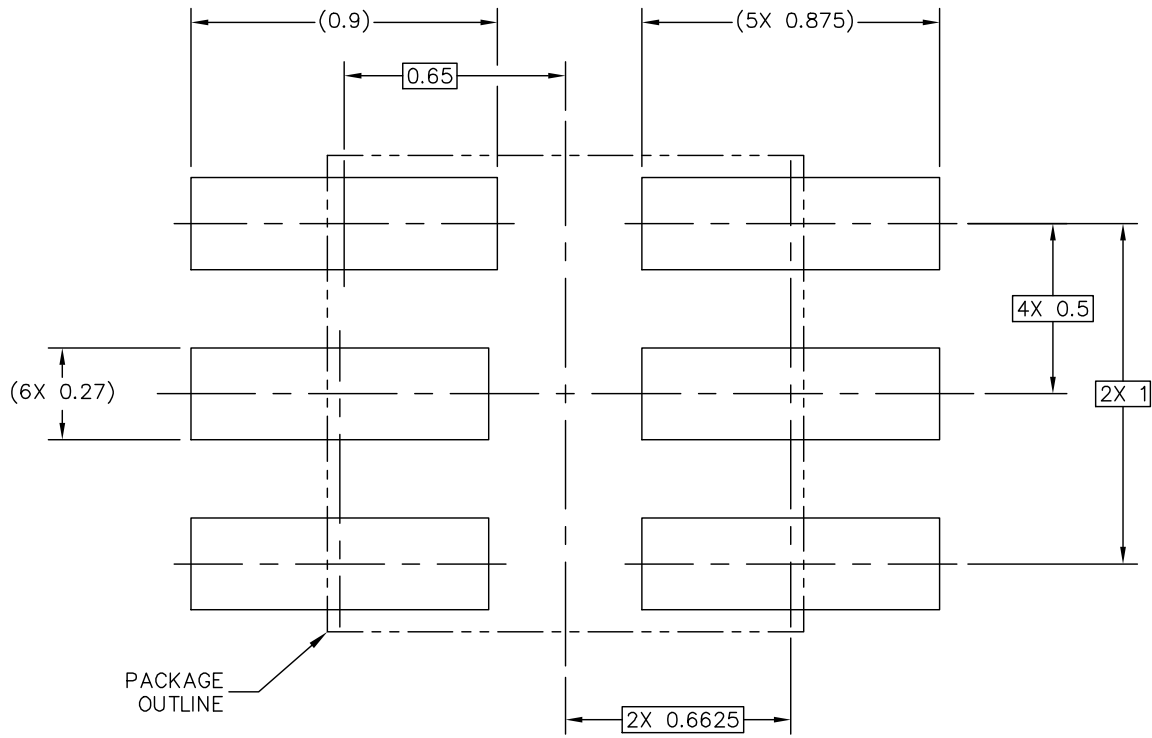

RECOMMENDED STENCIL THICKNESS 0.1

PCB DESIGN GUIDELINES – SOLDER PASTE STENCIL

THIS SHEET SERVES ONLY AS A GUIDELINE TO HELP DEVELOP A USER SPECIFIC SOLUTION. DEVELOPMENT EFFORT WILL STILL BE REQUIRED BY END USERS TO OPTIMIZE PCB MOUNTING PROCESSES AND BOARD DESIGN IN ORDER TO MEET INDIVIDUAL/SPECIFIC REQUIREMENTS.

© NXP B.V. ALL RIGHTS RESERVED

DATE: 26 AUG 2020

| | | | | |
|--|------------------------|--------------------------------|----------------|-------|
| MECHANICAL OUTLINE PRINT VERSION NOT TO SCALE | STANDARD: NON JEDEC | DRAWING NUMBER: 98ASA01688D | REVISION: 0 | PAGE: |
|--|------------------------|--------------------------------|----------------|-------|

Figure 25. Reflow soldering footprint part 3 for VSON6 (SOT2078-1)

14 References

- [1] AN1902 — Assembly guidelines for QFN (quad flat no-lead) and SON (small outline no-lead) packages
<https://www.nxp.com/docs/en/application-note/AN1902.pdf>

15 Revision history

Table 35. Revision history

| Document ID | Release date | Data sheet status | Change notice | Supersedes |
|----------------|--|--------------------|---------------|-------------|
| NMH1000 v.3 | 20231018 | Product data sheet | — | NMH1000 v.2 |
| Modifications: | <ul style="list-style-type: none"> • Section 7.5.3, revised the last paragraph. • Section 7.6.2.8, revised as follows: <ul style="list-style-type: none"> – Table 24, revised the Symbol row bit 7 from "RD/WR" to "—" and the Access row bit 7 from "R/W" to "—". – Table 25, removed the row for bit 7 from the table and removed "...from OTP..." from the description of bits 6 to 0. | | | |
| NMH1000 v.2 | 20230405 | Product data sheet | — | NMH1000 v.1 |
| NMH1000 v.1 | 20230303 | Product data sheet | — | — |

16 Legal information

16.1 Data sheet status

| Document status ^{[1][2]} | Product status ^[3] | Definition |
|-----------------------------------|-------------------------------|---|
| Objective [short] data sheet | Development | This document contains data from the objective specification for product development. |
| Preliminary [short] data sheet | Qualification | This document contains data from the preliminary specification. |
| Product [short] data sheet | Production | This document contains the product specification. |

[1] Please consult the most recently issued document before initiating or completing a design.

[2] The term 'short data sheet' is explained in section "Definitions".

[3] The product status of device(s) described in this document may have changed since this document was published and may differ in case of multiple devices. The latest product status information is available on the Internet at URL <http://www.nxp.com>.

16.2 Definitions

Draft — A draft status on a document indicates that the content is still under internal review and subject to formal approval, which may result in modifications or additions. NXP Semiconductors does not give any representations or warranties as to the accuracy or completeness of information included in a draft version of a document and shall have no liability for the consequences of use of such information.

Short data sheet — A short data sheet is an extract from a full data sheet with the same product type number(s) and title. A short data sheet is intended for quick reference only and should not be relied upon to contain detailed and full information. For detailed and full information see the relevant full data sheet, which is available on request via the local NXP Semiconductors sales office. In case of any inconsistency or conflict with the short data sheet, the full data sheet shall prevail.

Product specification — The information and data provided in a Product data sheet shall define the specification of the product as agreed between NXP Semiconductors and its customer, unless NXP Semiconductors and customer have explicitly agreed otherwise in writing. In no event however, shall an agreement be valid in which the NXP Semiconductors product is deemed to offer functions and qualities beyond those described in the Product data sheet.

16.3 Disclaimers

Limited warranty and liability — Information in this document is believed to be accurate and reliable. However, NXP Semiconductors does not give any representations or warranties, expressed or implied, as to the accuracy or completeness of such information and shall have no liability for the consequences of use of such information. NXP Semiconductors takes no responsibility for the content in this document if provided by an information source outside of NXP Semiconductors.

In no event shall NXP Semiconductors be liable for any indirect, incidental, punitive, special or consequential damages (including - without limitation - lost profits, lost savings, business interruption, costs related to the removal or replacement of any products or rework charges) whether or not such damages are based on tort (including negligence), warranty, breach of contract or any other legal theory.

Notwithstanding any damages that customer might incur for any reason whatsoever, NXP Semiconductors' aggregate and cumulative liability towards customer for the products described herein shall be limited in accordance with the Terms and conditions of commercial sale of NXP Semiconductors.

Right to make changes — NXP Semiconductors reserves the right to make changes to information published in this document, including without limitation specifications and product descriptions, at any time and without notice. This document supersedes and replaces all information supplied prior to the publication hereof.

Suitability for use — NXP Semiconductors products are not designed, authorized or warranted to be suitable for use in life support, life-critical or safety-critical systems or equipment, nor in applications where failure or malfunction of an NXP Semiconductors product can reasonably be expected to result in personal injury, death or severe property or environmental damage. NXP Semiconductors and its suppliers accept no liability for inclusion and/or use of NXP Semiconductors products in such equipment or applications and therefore such inclusion and/or use is at the customer's own risk.

Applications — Applications that are described herein for any of these products are for illustrative purposes only. NXP Semiconductors makes no representation or warranty that such applications will be suitable for the specified use without further testing or modification.

Customers are responsible for the design and operation of their applications and products using NXP Semiconductors products, and NXP Semiconductors accepts no liability for any assistance with applications or customer product design. It is customer's sole responsibility to determine whether the NXP Semiconductors product is suitable and fit for the customer's applications and products planned, as well as for the planned application and use of customer's third party customer(s). Customers should provide appropriate design and operating safeguards to minimize the risks associated with their applications and products.

NXP Semiconductors does not accept any liability related to any default, damage, costs or problem which is based on any weakness or default in the customer's applications or products, or the application or use by customer's third party customer(s). Customer is responsible for doing all necessary testing for the customer's applications and products using NXP Semiconductors products in order to avoid a default of the applications and the products or of the application or use by customer's third party customer(s). NXP does not accept any liability in this respect.

Limiting values — Stress above one or more limiting values (as defined in the Absolute Maximum Ratings System of IEC 60134) will cause permanent damage to the device. Limiting values are stress ratings only and (proper) operation of the device at these or any other conditions above those given in the Recommended operating conditions section (if present) or the Characteristics sections of this document is not warranted. Constant or repeated exposure to limiting values will permanently and irreversibly affect the quality and reliability of the device.

Terms and conditions of commercial sale — NXP Semiconductors products are sold subject to the general terms and conditions of commercial sale, as published at <http://www.nxp.com/profile/terms>, unless otherwise agreed in a valid written individual agreement. In case an individual agreement is concluded only the terms and conditions of the respective agreement shall apply. NXP Semiconductors hereby expressly objects to applying the customer's general terms and conditions with regard to the purchase of NXP Semiconductors products by customer.

No offer to sell or license — Nothing in this document may be interpreted or construed as an offer to sell products that is open for acceptance or the grant, conveyance or implication of any license under any copyrights, patents or other industrial or intellectual property rights.

Quick reference data — The Quick reference data is an extract of the product data given in the Limiting values and Characteristics sections of this document, and as such is not complete, exhaustive or legally binding.

Export control — This document as well as the item(s) described herein may be subject to export control regulations. Export might require a prior authorization from competent authorities.

Suitability for use in non-automotive qualified products — Unless this document expressly states that this specific NXP Semiconductors product is automotive qualified, the product is not suitable for automotive use. It is neither qualified nor tested in accordance with automotive testing or application requirements. NXP Semiconductors accepts no liability for inclusion and/or use of non-automotive qualified products in automotive equipment or applications.

In the event that customer uses the product for design-in and use in automotive applications to automotive specifications and standards, customer (a) shall use the product without NXP Semiconductors' warranty of the product for such automotive applications, use and specifications, and (b) whenever customer uses the product for automotive applications beyond NXP Semiconductors' specifications such use shall be solely at customer's own risk, and (c) customer fully indemnifies NXP Semiconductors for any liability, damages or failed product claims resulting from customer design and use of the product for automotive applications beyond NXP Semiconductors' standard warranty and NXP Semiconductors' product specifications.

Translations — A non-English (translated) version of a document, including the legal information in that document, is for reference only. The English version shall prevail in case of any discrepancy between the translated and English versions.

Security — Customer understands that all NXP products may be subject to unidentified vulnerabilities or may support established security standards or specifications with known limitations. Customer is responsible for the design and operation of its applications and products throughout their lifecycles to reduce the effect of these vulnerabilities on customer's applications and products. Customer's responsibility also extends to other open and/or proprietary technologies supported by NXP products for use in customer's applications. NXP accepts no liability for any vulnerability. Customer should regularly check security updates from NXP and follow up appropriately.

Customer shall select products with security features that best meet rules, regulations, and standards of the intended application and make the ultimate design decisions regarding its products and is solely responsible for compliance with all legal, regulatory, and security related requirements concerning its products, regardless of any information or support that may be provided by NXP.

NXP has a Product Security Incident Response Team (PSIRT) (reachable at PSIRT@nxp.com) that manages the investigation, reporting, and solution release to security vulnerabilities of NXP products.

NXP B.V. — NXP B.V. is not an operating company and it does not distribute or sell products.

16.4 Trademarks

Notice: All referenced brands, product names, service names, and trademarks are the property of their respective owners.

NXP — wordmark and logo are trademarks of NXP B.V.

I2C-bus — logo is a trademark of NXP B.V.

Tables

| | | | | | |
|----------|---|----|----------|---|----|
| Tab. 1. | Ordering information | 1 | Tab. 19. | USER_CLEAR_THRESH – User selectable output, clear threshold, N or S (address \$05h) bit description | 15 |
| Tab. 2. | Pin description | 4 | Tab. 20. | USER_ODR – User selectable sleep sample output data rates (address \$06h) bit allocation | 15 |
| Tab. 3. | Fixed threshold selection | 6 | Tab. 21. | USER_ODR – User selectable sleep sample output data rates (address \$06h) bit description | 15 |
| Tab. 4. | User-defined assert thresholds | 6 | Tab. 22. | WHO_AM_I - I2C configured identifier (address \$08h) bit allocation | 15 |
| Tab. 5. | User-defined output clear thresholds | 6 | Tab. 23. | WHO_AM_I - I2C configured identifier (address \$08h) bit description | 16 |
| Tab. 6. | Sample rate selection | 7 | Tab. 24. | I2C_ADDR - I2C configured identifier (address \$09h) bit allocation | 16 |
| Tab. 7. | I2C mode user-defined sample rate | 7 | Tab. 25. | I2C_ADDR - I2C configured identifier (address \$09h) bit description | 16 |
| Tab. 8. | User-defined output assert and clear states | 8 | Tab. 26. | Limiting values | 16 |
| Tab. 9. | Register map overview | 10 | Tab. 27. | Operating conditions | 17 |
| Tab. 10. | STATUS – Status reporting of modes and selections (address \$00h) bit allocation | 11 | Tab. 28. | Supply currents | 18 |
| Tab. 11. | STATUS – Status reporting of modes and selections (address \$00h) bit descriptions | 11 | Tab. 29. | Clocks and rates | 18 |
| Tab. 12. | CONTROL_Reg1 – Control of operations(address \$01h) bit allocation | 12 | Tab. 30. | I2C pin thresholds | 19 |
| Tab. 13. | CONTROL_Reg1 – Control of operations (address \$01h) bit description | 12 | Tab. 31. | Serial data timing characteristics | 19 |
| Tab. 14. | OUT_M_REG – Magnetic strength report (address \$03h) bit allocation | 13 | Tab. 32. | Magnetic field characteristics | 20 |
| Tab. 15. | OUT_M_REG – Magnetic strength report (address \$03h) bit description | 14 | Tab. 33. | I2C user mode, recommended lowest USER_ASSERT_THRESH [7:3] output assertion | 21 |
| Tab. 16. | USER_ASSERT_THRESH – User selectable output, assert threshold, N or S (address \$04h) bit allocation | 14 | Tab. 34. | I2C user mode, recommended highest USER_CLEAR_THRESH [7:3] output clear | 21 |
| Tab. 17. | USER_ASSERT_THRESH – User selectable output, assert threshold, N or S (address \$04h) bit description | 14 | Tab. 35. | Revision history | 30 |
| Tab. 18. | USER_CLEAR_THRESH – User selectable output, clear threshold, N or S (address \$05h) bit allocation | 14 | | | |

Figures

| | | | | | |
|----------|---|----|----------|---|----|
| Fig. 1. | Block diagram | 2 | Fig. 15. | Standalone mode, High threshold, Medium sample rate | 22 |
| Fig. 2. | Pin configuration | 3 | Fig. 16. | Standalone mode, Low threshold, Low sample rate | 22 |
| Fig. 3. | Magnetic field vs. package orientation | 4 | Fig. 17. | Standalone mode, Medium threshold, Low sample rate | 23 |
| Fig. 4. | NMH1000 functional state flow diagram | 5 | Fig. 18. | Standalone mode, High threshold, Low sample rate | 23 |
| Fig. 5. | Output operation | 8 | Fig. 19. | I2C mode | 23 |
| Fig. 6. | I2C timing diagram | 9 | Fig. 20. | Package outline VSON6 (SOT2078-1) | 24 |
| Fig. 7. | I2C write operation | 10 | Fig. 21. | Package outline detail of VSON6 (SOT2078-1) | 25 |
| Fig. 8. | I2C read operation | 10 | Fig. 22. | Package outline note VSON6 (SOT2078-1) | 26 |
| Fig. 9. | Output operation at each of the three standalone threshold settings | 20 | Fig. 23. | Reflow soldering footprint part 1 for VSON6 (SOT2078-1) | 27 |
| Fig. 10. | Standalone mode, Low threshold, High sample rate | 21 | Fig. 24. | Reflow soldering footprint part 2 for VSON6 (SOT2078-1) | 28 |
| Fig. 11. | Standalone mode, Medium threshold, High sample rate | 21 | Fig. 25. | Reflow soldering footprint part 3 for VSON6 (SOT2078-1) | 29 |
| Fig. 12. | Standalone mode, High threshold, High sample rate | 21 | | | |
| Fig. 13. | Standalone mode, Low threshold, Medium sample rate | 22 | | | |
| Fig. 14. | Standalone mode, Medium threshold, Medium sample rate | 22 | | | |



Contents

| | | | | | |
|----------|---|----------|-----------|--|-----------|
| 1 | General description | 1 | 7.6.2.8 | I2C configured identifier (I2C_ADDR) (\$09h) | 16 |
| 2 | Features and benefits | 1 | 8 | Limiting values | 16 |
| 3 | Applications | 1 | 9 | Recommended operating conditions | 17 |
| 4 | Ordering information | 1 | 10 | Characteristics | 18 |
| 5 | Block diagram | 2 | 10.1 | Supply currents | 18 |
| 5.1 | Block descriptions | 3 | 10.2 | Clocks and rates | 18 |
| 6 | Pinning information | 3 | 10.3 | I2C pin thresholds | 19 |
| 6.1 | Pinning | 3 | 10.4 | Serial data timing characteristics | 19 |
| 6.2 | Pin description | 3 | 10.5 | Magnetic field characteristics | 20 |
| 6.3 | Orientation | 4 | 10.6 | I2C user mode, output assertion | 21 |
| 7 | Functional description | 5 | 10.7 | I2C user mode, output clear | 21 |
| 7.1 | Operating modes | 5 | 11 | Application information | 21 |
| 7.1.1 | Functional states | 5 | 12 | Package outline | 24 |
| 7.1.2 | Interface Operational Modes | 5 | 13 | Soldering information | 27 |
| 7.2 | Threshold configurations | 6 | 14 | References | 30 |
| 7.2.1 | Fixed thresholds | 6 | 15 | Revision history | 30 |
| 7.2.1.1 | Fixed threshold selection via VTH pin voltage | 6 | 16 | Legal information | 31 |
| 7.2.2 | User-defined threshold | 6 | | | |
| 7.3 | Sample rate configurations | 7 | | | |
| 7.3.1 | Fixed sample rates | 7 | | | |
| 7.3.1.1 | Sample rate selection via VODR pin voltage | 7 | | | |
| 7.3.2 | User-defined sample rate | 7 | | | |
| 7.4 | Output control function description | 7 | | | |
| 7.4.1 | Output hysteresis | 7 | | | |
| 7.4.2 | Control Output State | 8 | | | |
| 7.4.2.1 | Standalone mode output assert / clear states | 8 | | | |
| 7.4.2.2 | User-defined output assert / clear states | 8 | | | |
| 7.5 | I2C serial data function description | 8 | | | |
| 7.5.1 | I2C pin functions | 8 | | | |
| 7.5.2 | I2C timing diagram | 9 | | | |
| 7.5.3 | I2C operation | 9 | | | |
| 7.5.4 | I2C protocol diagram | 10 | | | |
| 7.6 | Register map | 10 | | | |
| 7.6.1 | Register overview | 10 | | | |
| 7.6.2 | Register details | 11 | | | |
| 7.6.2.1 | Status reporting of modes and selections (STATUS) (\$00h) | 11 | | | |
| 7.6.2.2 | Control of operations (CONTROL_Reg1) (\$01h) | 12 | | | |
| 7.6.2.3 | Magnetic strength report (OUT_M_REG) (\$03h) | 13 | | | |
| 7.6.2.4 | User selectable output, assert threshold, N or S (USER_ASSERT_THRESH) (\$04h) | 14 | | | |
| 7.6.2.5 | User selectable output, clear threshold, N or S (USER_CLEAR_THRESH) (\$05h) | 14 | | | |
| 7.6.2.6 | User selectable sleep sample output data rates (USER_ODR) (\$06h) | 15 | | | |
| 7.6.2.7 | I2C configured identifier (WHO_AM_I) (\$08h) | 15 | | | |

Please be aware that important notices concerning this document and the product(s) described herein, have been included in section 'Legal information'.

Looking for pricing, stock, or lifecycle information?

Click below to explore more details on WIN SOURCE:

-  [View MYRGP330060W21RC on WIN SOURCE](#)
-  [Murata Power Solutions Inc. Information](#)

Optimize Your Supply Chain with WIN SOURCE Solutions

-  Global Sourcing Solution
-  Obsolete Management
-  Cost Control Management
-  Shortage Management
-  Alternative Solution
-  Excess Inventory Management