



**THE DATASHEET OF  
P4FL15A\_R1\_00001**



## SN74LVC2G08-Q1 Dual 2-Input Positive-AND Gate

### 1 Features

- AEC-Q100 Qualified With the Following Results:
  - Device Temperature Grade 1:  $-40^{\circ}\text{C}$  to  $+125^{\circ}\text{C}$  Ambient Operating Temperature Range (DCU package)
  - Device Temperature Grade 3:  $-40^{\circ}\text{C}$  to  $+85^{\circ}\text{C}$  Ambient Operating Temperature Range (DCT package)
- Supports 5-V  $V_{\text{CC}}$  Operation
- Inputs Accept Voltages to 5.5 V
- Low Power Consumption, 10- $\mu\text{A}$  Max  $I_{\text{CC}}$
- $\pm 24\text{-mA}$  Output Drive at 3.3 V
- $I_{\text{off}}$  Supports Partial-Power-Down Mode Operation
- Can be Used as a Down Translator to Translate Input from a Maximum of 5.5 V Down to the  $V_{\text{CC}}$  Level.
- Latch-Up Performance Exceeds 100 mA Per JESD 78, Class II

### 2 Applications

- Combine Power Good signals for Multiple Power Rails
- Prevent a Signal from Being Passed Until a Condition is True
- Combine Active-Low Error Signals

### 3 Description

This dual 2-input positive-AND gate is designed for 1.65-V to 5.5-V  $V_{\text{CC}}$  operation.

The SN74LVC2G08-Q1 performs the Boolean function  $Y = A \cdot B$  or  $Y = \overline{\overline{A} + \overline{B}}$  in positive logic.

This device is fully specified for partial-power-down applications using  $I_{\text{off}}$ . The  $I_{\text{off}}$  circuitry disables the outputs, preventing damaging current backflow through the device when it is powered down.

#### Device Information (1)

PART NUMBER	PACKAGE	BODY SIZE (NOM)
SN74LVC2G08DCT-Q1	SM8 (8)	2.95 mm $\times$ 2.80 mm
SN74LVC2G08DCU-Q1	VSSOP (8)	2.30 mm $\times$ 2.00 mm

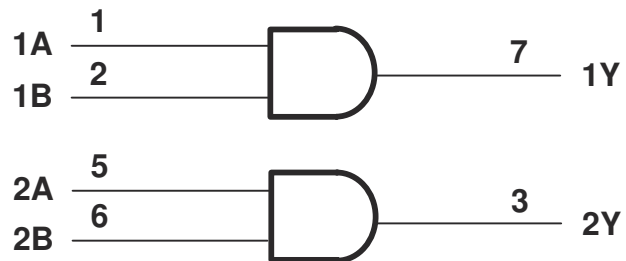

Figure 3-1. Logic Diagram (Positive Logic)



## Table of Contents

<b>1 Features</b> .....	1	9.3 Feature Description.....	9
<b>2 Applications</b> .....	1	9.4 Device Functional Modes.....	10
<b>3 Description</b> .....	1	<b>10 Application and Implementation</b> .....	11
<b>4 Revision History</b> .....	2	10.1 Application Information.....	11
<b>5 Pin Configuration and Functions</b> .....	3	10.2 Typical Application.....	11
<b>6 Specifications</b> .....	4	<b>11 Application Curves</b> .....	12
6.1 Absolute Maximum Ratings.....	4	<b>12 Power Supply Recommendations</b> .....	12
6.2 ESD Ratings.....	4	<b>13 Layout</b> .....	12
6.3 Recommended Operating Conditions.....	5	13.1 Layout Guidelines.....	12
6.4 Thermal Information.....	5	13.2 Layout Example.....	12
6.5 Electrical Characteristics.....	6	<b>14 Device and Documentation Support</b> .....	13
6.6 Switching Characteristics.....	6	14.1 Receiving Notification of Documentation Updates.....	13
6.7 Operating Characteristics.....	6	14.2 Support Resources.....	13
<b>7 Typical Characteristics</b> .....	7	14.3 Trademarks.....	13
<b>8 Parameter Measurement Information</b> .....	8	14.4 Glossary.....	13
<b>9 Detailed Description</b> .....	9	14.5 Electrostatic Discharge Caution.....	13
9.1 Overview.....	9	<b>15 Mechanical, Packaging, and Orderable Information</b> .....	13
9.2 Functional Block Diagram.....	9		

## 4 Revision History

NOTE: Page numbers for previous revisions may differ from page numbers in the current version.

Changes from Revision D (March 2010) to Revision E (October 2020)	Page
• Updated the numbering format for tables, figures, and cross-references throughout the document.....	1
• Removed Typical $V_{OLP}$ (Output Ground Bound) $<0.8$ V at $V_{CC} = 3.3$ V, $T_A = 25^\circ\text{C}$ from <i>Features</i> section.....	1
• Removed Typical $V_{OHV}$ (Output $V_{OHV}$ Undershoot) $>2$ V at $V_{CC} = 3.3$ V, $T_A = 25^\circ\text{C}$ from <i>Features</i> section.....	1
• Removed the <i>Ordering Information</i> table from <i>Description</i> section.....	1
• Added a <i>Device Information</i> table to the <i>Description</i> section.....	1
• Added the <i>Logic Diagram (Positive Logic)</i> figure to the <i>Description</i> section.....	1
• Added the <i>Pin Configuration and Functions</i> section.....	3
• Added SN74LVC2G08DCT-Q1 and SN74LVC2G08DCU-Q1 minimum and maximum operating free-air temperature ranges to the <i>Recommended Operating Conditions</i> section.....	5
• Added the $T_A$ temperature ranges ( $-40^\circ\text{C}$ to $85^\circ\text{C}$ and $-40^\circ\text{C}$ to $125^\circ\text{C}$ ) for the $t_{pd}$ parameter to the <i>Switching Characteristics</i> section.....	6
• Added the <i>Typical Characteristics</i> section.....	7
• Added the <i>Overview</i> section.....	9
• Added the <i>Functional Block Diagram</i> section.....	9
• Added the <i>Features Description</i> section.....	9
• Added the <i>Device Functional Modes</i> section.....	10
• Added the <i>Application and Implementation</i> section.....	11
• Added the <i>Application Information</i> section.....	11
• Added the <i>Power Supply Recommendations</i> section.....	12
• Added the <i>Layout</i> section.....	12
• Added the <i>Layout Guidelines</i> section.....	12
• Added the <i>Layout Example</i> section.....	12
• Updated the <i>Device and Documentation Support</i> section.....	13

## 5 Pin Configuration and Functions

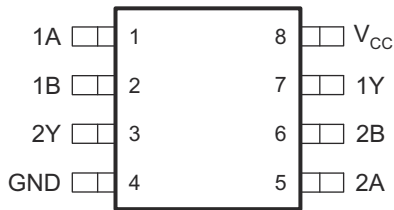

**Figure 5-1. DCT Package  
8-Pin SM8  
Top View**

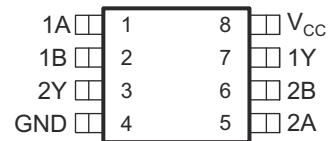

**Figure 5-2. DCU Package  
8-Pin VSSOP  
Top View**

### Pin Functions

PIN		I/O	DESCRIPTION
NAME	NO.		
1A	1	I	Channel 1 logic input
1B	2	I	Channel 1 logic input
1Y	7	O	Logic level output
2A	5	I	Channel 2 logic input
2B	6	I	Channel 2 logic input
2Y	3	O	Logic level output
GND	4	—	Ground
V <sub>CC</sub>	8	—	Power Supply

## 6 Specifications

### 6.1 Absolute Maximum Ratings

over operating free-air temperature range (unless otherwise noted)

		MIN	MAX	UNIT
$V_{CC}$	Supply voltage range	-0.5	6.5	V
$V_I$	Input voltage range <sup>(1)</sup>	-0.5	6.5	V
$V_O$	Voltage range applied to any output in the high-impedance or power-off state <sup>(1)</sup>	-0.5	6.5	V
$V_O$	Voltage range applied to any output in the high or low state <sup>(1) (2)</sup>	-0.5	$V_{CC} + 0.5$	V
$I_{IK}$	Input clamp current		-50	mA
$I_{OK}$	Output clamp current		-50	mA
$I_O$	Continuous output current		±50	mA
	Continuous current through $V_{CC}$ or GND		±100	mA
$T_J$	Junction temperature		150	°C
$T_{stg}$	Storage temperature range	-65	150	°C

(1) The input and output negative-voltage ratings may be exceeded if the input and output current ratings are observed.

(2) The value of  $V_{CC}$  is provided in the *Recommended Operating Conditions* table.

### 6.2 ESD Ratings

			VALUE	UNIT
$V_{(ESD)}$	Electrostatic discharge	Human body model (HBM), per AEC Q100-002 <sup>(1)</sup>	±2000	V
		Charged device model (CDM), per AEC Q100-011	±1000	

(1) AEC Q100-002 indicates HBM stressing is done in accordance with the ANSI/ESDA/JEDEC JS-001 specification.

### 6.3 Recommended Operating Conditions

			MIN	MAX	UNIT
V <sub>CC</sub>	Supply voltage	Operating	1.65	5.5	V
		Data retention only	1.5		
V <sub>IH</sub>	High-level input voltage	V <sub>CC</sub> = 1.65 V to 1.95 V	0.65 × V <sub>CC</sub>		V
		V <sub>CC</sub> = 2.3 V to 2.7 V	1.7		
		V <sub>CC</sub> = 3 V to 3.6 V	2		
		V <sub>CC</sub> = 4.5 V to 5.5 V	0.7 × V <sub>CC</sub>		
V <sub>IL</sub>	Low-level input voltage	V <sub>CC</sub> = 1.65 V to 1.95 V		0.35 × V <sub>CC</sub>	V
		V <sub>CC</sub> = 2.3 V to 2.7 V		0.7	
		V <sub>CC</sub> = 3 V to 3.6 V		0.8	
		V <sub>CC</sub> = 4.5 V to 5.5 V		0.3 × V <sub>CC</sub>	
V <sub>I</sub>	Input voltage		0	5.5	V
V <sub>O</sub>	Output voltage		0	V <sub>CC</sub>	V
I <sub>OH</sub>	High-level output current	V <sub>CC</sub> = 1.65 V		-4	mA
		V <sub>CC</sub> = 2.3 V		-8	
		V <sub>CC</sub> = 3 V		-16	
		V <sub>CC</sub> = 4.5 V		-24	
I <sub>OL</sub>	Low-level output current	V <sub>CC</sub> = 1.65 V		4	mA
		V <sub>CC</sub> = 2.3 V		8	
		V <sub>CC</sub> = 3 V		16	
		V <sub>CC</sub> = 4.5 V		24	
Δt/Δv	Input transition rise or fall rate	V <sub>CC</sub> = 1.8 V ± 0.15 V, 2.5 V ± 0.2 V		20	ns/V
		V <sub>CC</sub> = 3.3 V ± 0.3 V		10	
		V <sub>CC</sub> = 5 V ± 0.5 V		5	
T <sub>A</sub>	Operating free-air temperature	SN74LVC2G08DCU-Q1	-40	125	°C
		SN74LVC2G08DCT-Q1	-40	85	

### 6.4 Thermal Information

THERMAL METRIC <sup>(1)</sup>		SN74LVC2G08-Q1		UNIT
		DCT (SM8)	DCU (VSSOP)	
		8 PINS	8 PINS	
R <sub>θJA</sub>	Junction-to-ambient thermal resistance	220	201.5	°C/W
R <sub>θJC(top)</sub>	Junction-to-case (top) thermal resistance	117.2	91.9	°C/W
R <sub>θJB</sub>	Junction-to-board thermal resistance	100	122.6	°C/W
Ψ <sub>JT</sub>	Junction-to-top characterization parameter	42.4	31.8	°C/W
Ψ <sub>JB</sub>	Junction-to-board characterization parameter	98.9	122.1	°C/W

(1) For more information about traditional and new thermal metrics, see the *Semiconductor and IC Package Thermal Metrics* application report, [SPRA953](#).

## 6.5 Electrical Characteristics

over recommended operating free-air temperature range (unless otherwise noted)

PARAMETER		TEST CONDITIONS	V <sub>CC</sub>	MIN	TYP <sup>(1)</sup>	MAX	UNIT
V <sub>OH</sub>		I <sub>OH</sub> = –100 μA	1.65 V to 5.5 V	V <sub>CC</sub> – 0.1			V
		I <sub>OH</sub> = –4 mA	1.65 V	1.2			
		I <sub>OH</sub> = –8 mA	2.3 V	1.9			
		I <sub>OH</sub> = –16 mA	3 V	2.4			
		I <sub>OH</sub> = –24 mA		2.3			
		I <sub>OH</sub> = –32 mA	4.5 V	3.8			
V <sub>OL</sub>		I <sub>OL</sub> = 100 μA	1.65 V to 5.5 V			0.1	V
		I <sub>OL</sub> = 4 mA	1.65 V			0.45	
		I <sub>OL</sub> = 8 mA	2.3 V			0.3	
		I <sub>OL</sub> = 16 mA	3 V			0.4	
		I <sub>OL</sub> = 24 mA				0.55	
		I <sub>OL</sub> = 32 mA	4.5 V			0.55	
I <sub>I</sub>	A or B inputs	V <sub>I</sub> = 5.5 V or GND	0 to 5.5 V			±5	μA
I <sub>off</sub>		V <sub>I</sub> or V <sub>O</sub> = 5.5 V	0			±10	μA
I <sub>CC</sub>		V <sub>I</sub> = 5.5 V or GND, I <sub>O</sub> = 0	1.65 V to 5.5 V			10	μA
ΔI <sub>CC</sub>		One input at V <sub>CC</sub> – 0.6 V, Other inputs at V <sub>CC</sub> or GND, T <sub>A</sub> = –40°C to 85°C	3 V to 5.5 V			500	μA
C <sub>i</sub>		V <sub>I</sub> = V <sub>CC</sub> or GND, T <sub>A</sub> = –40°C to 85°C	3.3 V	5			pF

(1) All typical values are at V<sub>CC</sub> = 3.3 V, T<sub>A</sub> = 25°C.

## 6.6 Switching Characteristics

PARAMETER	FROM (INPUT)	TO (OUTPUT)	T <sub>A</sub>	V <sub>CC</sub>	MIN	MAX	UNIT
t <sub>pd</sub>	A or B	Y	–40°C to 85°C	V <sub>CC</sub> = 1.8 V ± 0.15 V	2.6	9	ns
				V <sub>CC</sub> = 2.5 V ± 0.2 V	1	5.1	
				V <sub>CC</sub> = 3.3 V ± 0.3 V	1	4.7	
				V <sub>CC</sub> = 5 V ± 0.5 V	1	3.8	
			–40°C to 125°C	V <sub>CC</sub> = 1.8 V ± 0.15 V	2.6	9.8	
				V <sub>CC</sub> = 2.5 V ± 0.2 V	1	5.8	
				V <sub>CC</sub> = 3.3 V ± 0.3 V	1	5.3	
				V <sub>CC</sub> = 5 V ± 0.5 V	1	4.8	

## 6.7 Operating Characteristics

T<sub>A</sub> = 25°C

PARAMETER	TEST CONDITIONS	V <sub>CC</sub> = 1.8 V	V <sub>CC</sub> = 2.5 V	V <sub>CC</sub> = 3.3 V	V <sub>CC</sub> = 5 V	UNIT	
		TYP	TYP	TYP	TYP		
C <sub>pd</sub>	Power dissipation capacitance	f = 10 MHz	17	17	17	20	pF

## 7 Typical Characteristics

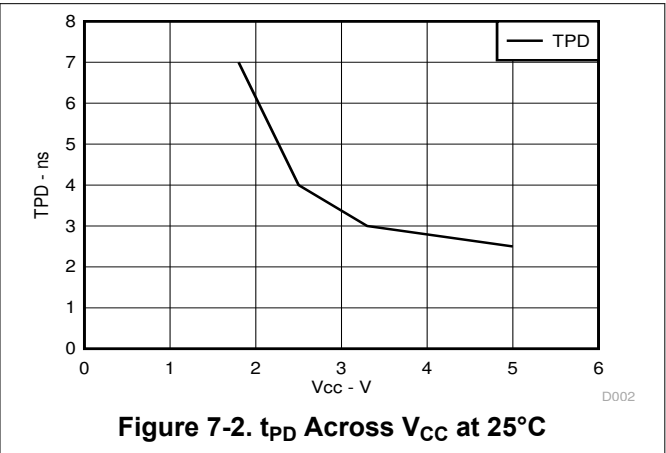
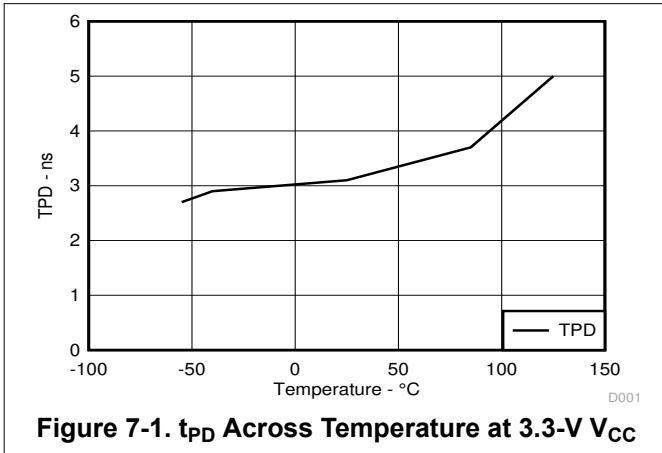

## 8 Parameter Measurement Information

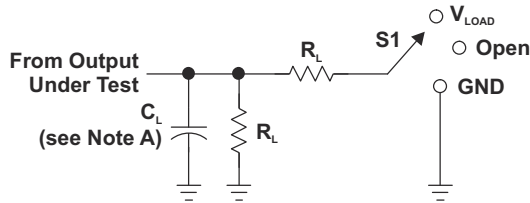

LOAD CIRCUIT

TEST	S1
$t_{PLH}/t_{PHL}$	Open
$t_{PLZ}/t_{PZL}$	$V_{LOAD}$
$t_{PHZ}/t_{PZH}$	GND

$V_{CC}$	INPUTS		$V_M$	$V_{LOAD}$	$C_L$	$R_L$	$V_D$
	$V_I$	$t/t_i$					
$1.8\text{ V} \pm 0.15\text{ V}$	$V_{CC}$	£2 ns	$V_{CC}/2$	$2 \times V_{CC}$	30 pF	1 kW	0.15 V
$2.5\text{ V} \pm 0.2\text{ V}$	$V_{CC}$	£2 ns	$V_{CC}/2$	$2 \times V_{CC}$	30 pF	500 W	0.15 V
$3.3\text{ V} \pm 0.3\text{ V}$	3 V	£2.5 ns	1.5 V	6 V	50 pF	500 W	0.3 V
$5\text{ V} \pm 0.5\text{ V}$	$V_{CC}$	£2.5 ns	$V_{CC}/2$	$2 \times V_{CC}$	50 pF	500 W	0.3 V

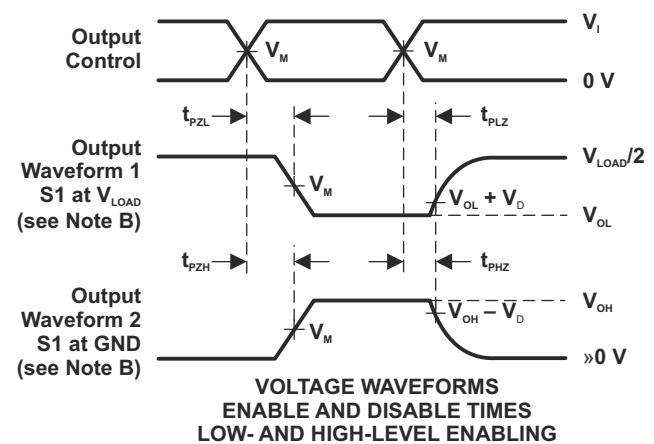
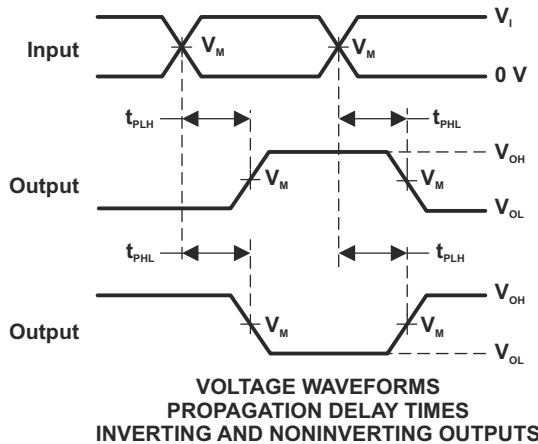
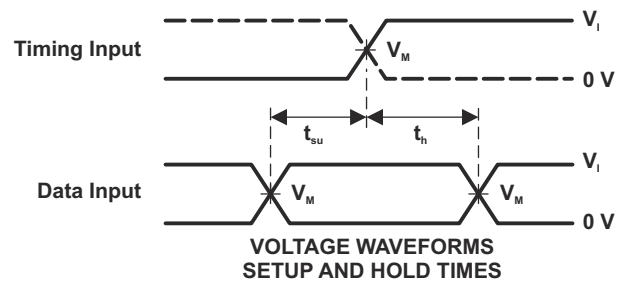
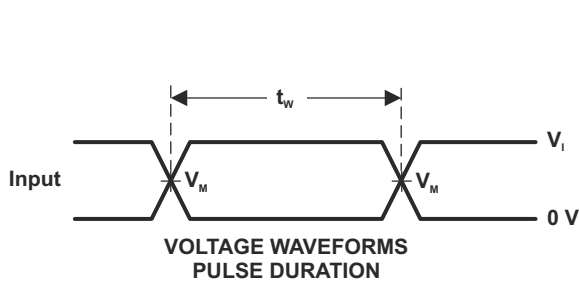

- NOTES: A.  $C_L$  includes probe and jig capacitance.  
 B. Waveform 1 is for an output with internal conditions such that the output is low, except when disabled by the output control. Waveform 2 is for an output with internal conditions such that the output is high, except when disabled by the output control.  
 C. All input pulses are supplied by generators having the following characteristics: PRR £ 10 MHz,  $Z_o = 50\ \Omega$ .  
 D. The outputs are measured one at a time, with one transition per measurement.

Figure 8-1. Load Circuit and Voltage Waveforms

## 9 Detailed Description

### 9.1 Overview

The SN74LVC2G08-Q1 device contains two 2-input positive AND gates and performs the Boolean function  $Y = A \cdot B$  or  $Y = \overline{A + B}$ . This device is fully specified for partial-power-down applications using Ioff. The Ioff circuitry disables the outputs, preventing damaging current backflow through the device when it is powered down.

### 9.2 Functional Block Diagram

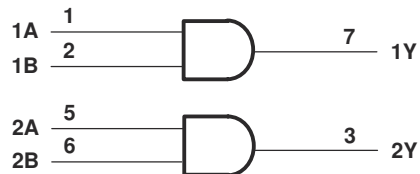

### 9.3 Feature Description

#### 9.3.1 Balanced CMOS Push-Pull Outputs

This device includes balanced CMOS push-pull outputs. The term "balanced" indicates that the device can sink and source similar currents. The drive capability of this device may create fast edges into light loads so routing and load conditions should be considered to prevent ringing. Additionally, the outputs of this device are capable of driving larger currents than the device can sustain without being damaged. It is important for the output power of the device to be limited to avoid damage due to overcurrent. The electrical and thermal limits defined in the *Absolute Maximum Ratings* must be followed at all times.

Unused push-pull CMOS outputs should be left disconnected.

#### 9.3.2 Standard CMOS Inputs

This device includes standard CMOS inputs. Standard CMOS inputs are high impedance and are typically modeled as a resistor in parallel with the input capacitance given in the *Electrical Characteristics*. The worst case resistance is calculated with the maximum input voltage, given in the *Absolute Maximum Ratings*, and the maximum input leakage current, given in the *Electrical Characteristics*, using Ohm's law ( $R = V \div I$ ).

Standard CMOS inputs require that input signals transition between valid logic states quickly, as defined by the input transition time or rate in the *Recommended Operating Conditions* table. Failing to meet this specification will result in excessive power consumption and could cause oscillations. More details can be found in [Implications of Slow or Floating CMOS Inputs](#).

Do not leave standard CMOS inputs floating at any time during operation. Unused inputs must be terminated at  $V_{CC}$  or GND. If a system will not be actively driving an input at all times, a pull-up or pull-down resistor can be added to provide a valid input voltage during these times. The resistor value will depend on multiple factors, however a 10-k $\Omega$  resistor is recommended and will typically meet all requirements.

#### 9.3.3 Clamp Diode Structure

The inputs and outputs to this device have negative clamping diodes only as depicted in [Figure 9-1](#).

#### CAUTION

Voltages beyond the values specified in the *Absolute Maximum Ratings* table can cause damage to the device. The input and output voltage ratings may be exceeded if the input and output clamp-current ratings are observed.

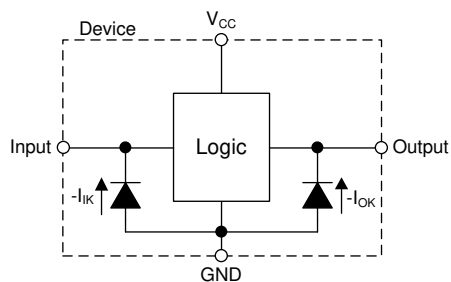

**Figure 9-1. Electrical Placement of Clamping Diodes for Each Input and Output**

**9.3.4 Partial Power Down ( $I_{off}$ )**

This device includes circuitry to disable all outputs when the supply pin is held at 0 V. When disabled, the outputs will neither source nor sink current, regardless of the input voltages applied. The amount of leakage current at each output is defined by the  $I_{off}$  specification in the *Electrical Characteristics* table.

**9.4 Device Functional Modes**

Table 9-1 lists the functional modes of the SN74LVC2G08-Q1.

**Table 9-1. Function Table**

INPUTS		OUTPUT
A	B	Y
H	H	H
L	X	L
X	L	L

## 10 Application and Implementation

### Note

Information in the following applications sections is not part of the TI component specification, and TI does not warrant its accuracy or completeness. TI's customers are responsible for determining suitability of components for their purposes. Customers should validate and test their design implementation to confirm system functionality.

### 10.1 Application Information

The SN74LVC2G08-Q1 is a high-drive CMOS device that can be used for implementing AND logic with a high output drive, such as an LED application. It can produce 24 mA of drive current at 3.3 V, making it ideal for driving multiple outputs and good for high-speed applications up to 100 MHz. The inputs are 5.5-V tolerant allowing it to translate down to  $V_{CC}$ .

### 10.2 Typical Application

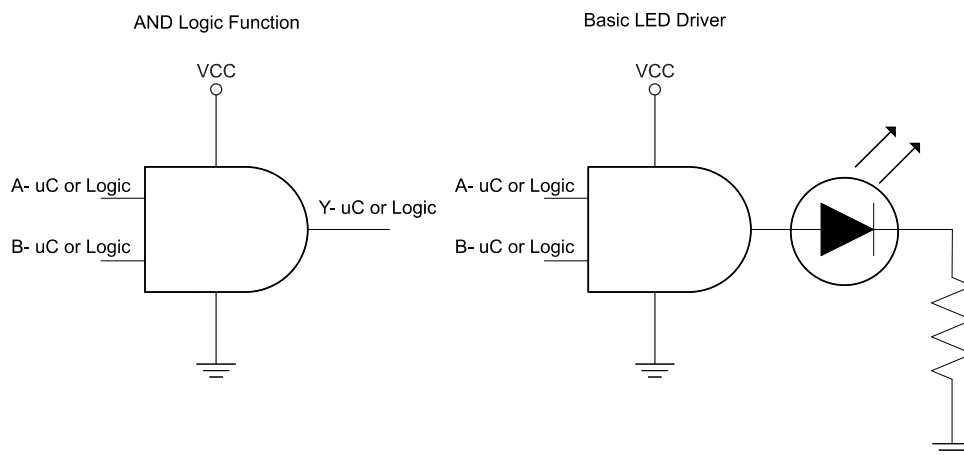

**Figure 10-1. Typical Application**

#### 10.2.1 Design Requirements

This device uses CMOS technology and has balanced output drive. Take care to avoid bus contention because it can drive currents that would exceed maximum limits. The high drive will also create fast edges into light loads so routing and load conditions must be considered to prevent ringing.

##### 10.2.1.1 Detailed Design Procedure

#### 1. Recommended Input Conditions

- Rise time and fall time specs. See  $(\Delta t/\Delta V)$  in the [Recommended Operating Conditions](#) table.
- Specified high and low levels. See ( $V_{IH}$  and  $V_{IL}$ ) in the [Recommended Operating Conditions](#) table.
- Inputs are overvoltage tolerant allowing them to go as high as ( $V_I$  maximum) in the [Recommended Operating Conditions](#) table at any valid  $V_{CC}$ .

#### 2. Recommended Output Conditions

- Load currents must not exceed ( $I_O$  maximum) per output and must not exceed total current (continuous current through  $V_{CC}$  or GND) for the part. These limits are located in the [Recommended Operating Conditions](#) table.
- Outputs must not be pulled above  $V_{CC}$  in normal operating conditions.

## 11 Application Curves

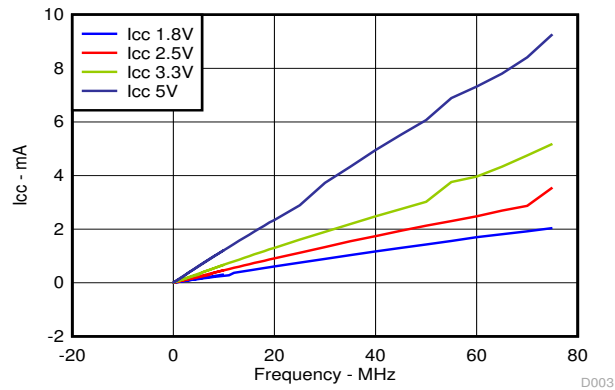

Figure 11-1. I<sub>CC</sub> vs Frequency

## 12 Power Supply Recommendations

The power supply can be any voltage between the minimum and maximum supply voltage rating located in the [Recommended Operating Conditions](#) table. Each V<sub>CC</sub> pin must have a good bypass capacitor to prevent power disturbance. For devices with a single supply, a 0.1- $\mu$ F capacitor is recommended and if there are multiple V<sub>CC</sub> pins then 0.01- $\mu$ F or 0.022- $\mu$ F capacitor is recommended for each power pin. It is ok to parallel multiple bypass capacitors to reject different frequencies of noise. 0.1- $\mu$ F and 1- $\mu$ F capacitors are commonly used in parallel. The bypass capacitor must be installed as close to the power pin as possible for best results

## 13 Layout

### 13.1 Layout Guidelines

When using multiple bit logic devices inputs must not ever float. In many cases, functions or parts of functions of digital logic devices are unused; for example, when only two inputs of a triple-input AND gate are used or only 3 of the 4 buffer gates are used. Such input pins must not be left unconnected because the undefined voltages at the outside connections result in undefined operational states. Specified below are the rules that must be observed under all circumstances. All unused inputs of digital logic devices must be connected to a high or low bias to prevent them from floating. The logic level that must be applied to any particular unused input depends on the function of the device. Generally they will be tied to GND or V<sub>CC</sub> whichever make more sense or is more convenient.

### 13.2 Layout Example

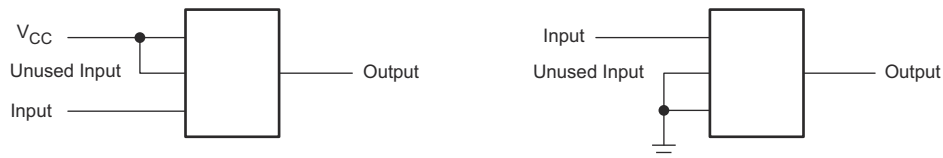

Figure 13-1. Layout Example

## 14 Device and Documentation Support

### 14.1 Receiving Notification of Documentation Updates

To receive notification of documentation updates, navigate to the device product folder on [ti.com](http://ti.com). Click on *Subscribe to updates* to register and receive a weekly digest of any product information that has changed. For change details, review the revision history included in any revised document.

### 14.2 Support Resources

TI E2E™ [support forums](#) are an engineer's go-to source for fast, verified answers and design help — straight from the experts. Search existing answers or ask your own question to get the quick design help you need.

Linked content is provided "AS IS" by the respective contributors. They do not constitute TI specifications and do not necessarily reflect TI's views; see TI's [Terms of Use](#).

### 14.3 Trademarks

TI E2E™ is a trademark of Texas Instruments.

All other trademarks are the property of their respective owners.

### 14.4 Glossary

[TI Glossary](#) This glossary lists and explains terms, acronyms, and definitions.

### 14.5 Electrostatic Discharge Caution



This integrated circuit can be damaged by ESD. Texas Instruments recommends that all integrated circuits be handled with appropriate precautions. Failure to observe proper handling and installation procedures can cause damage.

ESD damage can range from subtle performance degradation to complete device failure. Precision integrated circuits may be more susceptible to damage because very small parametric changes could cause the device not to meet its published specifications.

## 15 Mechanical, Packaging, and Orderable Information

The following pages include mechanical, packaging, and orderable information. This information is the most current data available for the designated devices. This data is subject to change without notice and revision of this document. For browser-based versions of this data sheet, refer to the left-hand navigation.

**PACKAGING INFORMATION**

Orderable part number	Status (1)	Material type (2)	Package   Pins	Package qty   Carrier	RoHS (3)	Lead finish/ Ball material (4)	MSL rating/ Peak reflow (5)	Op temp (°C)	Part marking (6)
<a href="#">SN74LVC2G08IDCTRQ1</a>	Active	Production	SSOP (DCT)   8	3000   LARGE T&R	Yes	NIPDAU	Level-1-260C-UNLIM	-40 to 85	C08 Z
SN74LVC2G08IDCTRQ1.B	Active	Production	SSOP (DCT)   8	3000   LARGE T&R	Yes	NIPDAU	Level-1-260C-UNLIM	-40 to 85	C08 Z
<a href="#">SN74LVC2G08QDCURQ1</a>	Active	Production	VSSOP (DCU)   8	3000   LARGE T&R	Yes	NIPDAU	Level-1-260C-UNLIM	-40 to 125	1HLRQ
SN74LVC2G08QDCURQ1.B	Active	Production	VSSOP (DCU)   8	3000   LARGE T&R	Yes	NIPDAU	Level-1-260C-UNLIM	-40 to 125	1HLRQ

(1) **Status:** For more details on status, see our [product life cycle](#).

(2) **Material type:** When designated, preproduction parts are prototypes/experimental devices, and are not yet approved or released for full production. Testing and final process, including without limitation quality assurance, reliability performance testing, and/or process qualification, may not yet be complete, and this item is subject to further changes or possible discontinuation. If available for ordering, purchases will be subject to an additional waiver at checkout, and are intended for early internal evaluation purposes only. These items are sold without warranties of any kind.

(3) **RoHS values:** Yes, No, RoHS Exempt. See the [TI RoHS Statement](#) for additional information and value definition.

(4) **Lead finish/Ball material:** Parts may have multiple material finish options. Finish options are separated by a vertical ruled line. Lead finish/Ball material values may wrap to two lines if the finish value exceeds the maximum column width.

(5) **MSL rating/Peak reflow:** The moisture sensitivity level ratings and peak solder (reflow) temperatures. In the event that a part has multiple moisture sensitivity ratings, only the lowest level per JEDEC standards is shown. Refer to the shipping label for the actual reflow temperature that will be used to mount the part to the printed circuit board.

(6) **Part marking:** There may be an additional marking, which relates to the logo, the lot trace code information, or the environmental category of the part.

Multiple part markings will be inside parentheses. Only one part marking contained in parentheses and separated by a "-" will appear on a part. If a line is indented then it is a continuation of the previous line and the two combined represent the entire part marking for that device.

**Important Information and Disclaimer:** The information provided on this page represents TI's knowledge and belief as of the date that it is provided. TI bases its knowledge and belief on information provided by third parties, and makes no representation or warranty as to the accuracy of such information. Efforts are underway to better integrate information from third parties. TI has taken and continues to take reasonable steps to provide representative and accurate information but may not have conducted destructive testing or chemical analysis on incoming materials and chemicals. TI and TI suppliers consider certain information to be proprietary, and thus CAS numbers and other limited information may not be available for release.

In no event shall TI's liability arising out of such information exceed the total purchase price of the TI part(s) at issue in this document sold by TI to Customer on an annual basis.

**OTHER QUALIFIED VERSIONS OF SN74LVC2G08-Q1 :**

- Catalog : [SN74LVC2G08](#)
- Enhanced Product : [SN74LVC2G08-EP](#)

## NOTE: Qualified Version Definitions:

- Catalog - TI's standard catalog product
- Enhanced Product - Supports Defense, Aerospace and Medical Applications

**TAPE AND REEL INFORMATION**

**QUADRANT ASSIGNMENTS FOR PIN 1 ORIENTATION IN TAPE**

\*All dimensions are nominal

Device	Package Type	Package Drawing	Pins	SPQ	Reel Diameter (mm)	Reel Width W1 (mm)	A0 (mm)	B0 (mm)	K0 (mm)	P1 (mm)	W (mm)	Pin1 Quadrant
SN74LVC2G08QDCURQ1	VSSOP	DCU	8	3000	180.0	8.4	2.25	3.35	1.05	4.0	8.0	Q3

TAPE AND REEL BOX DIMENSIONS



\*All dimensions are nominal

Device	Package Type	Package Drawing	Pins	SPQ	Length (mm)	Width (mm)	Height (mm)
SN74LVC2G08QDCURQ1	VSSOP	DCU	8	3000	183.0	183.0	20.0

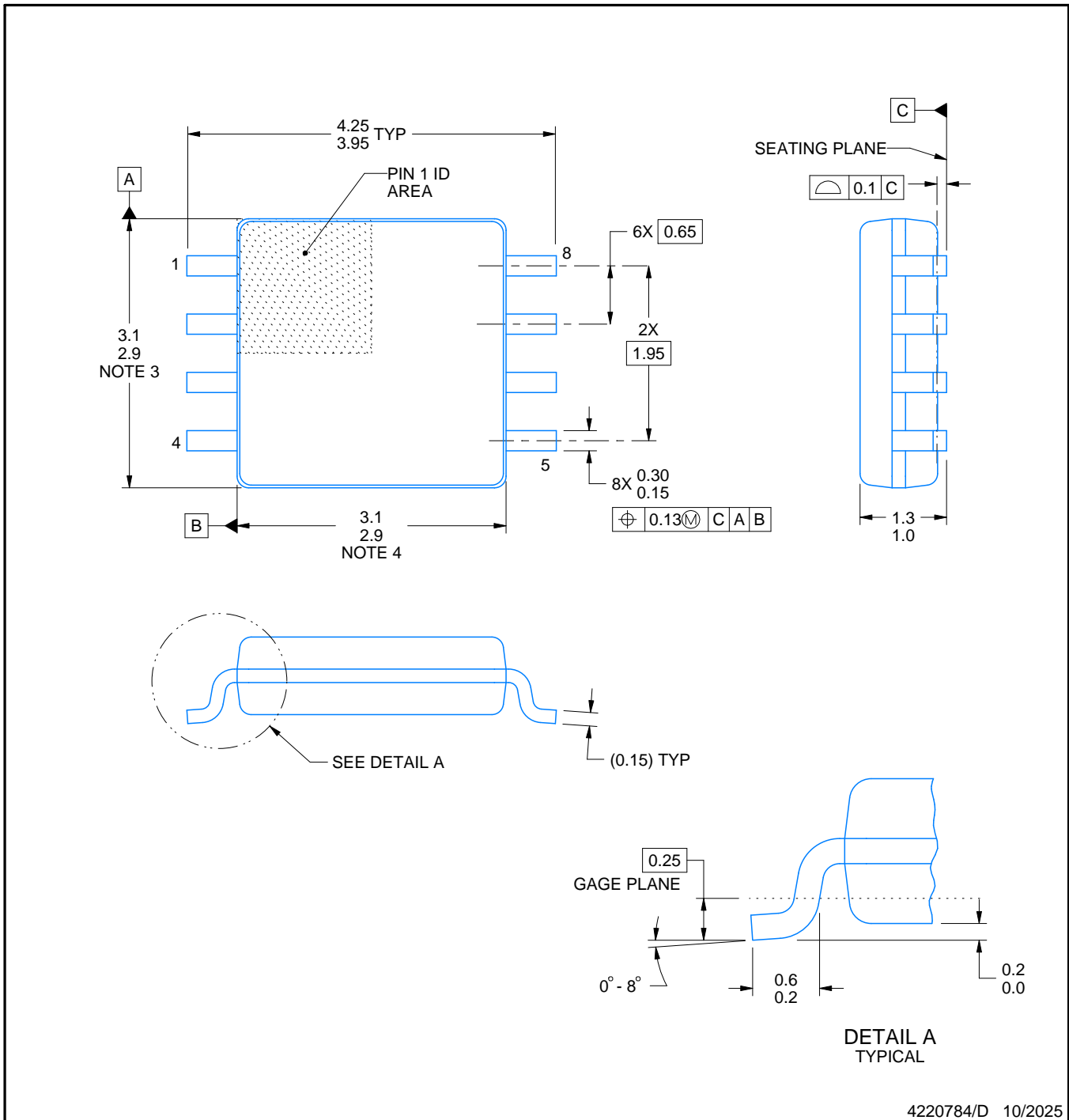
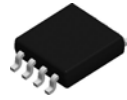

4220784/D 10/2025

NOTES:

1. All linear dimensions are in millimeters. Dimensions in parenthesis are for reference only. Dimensioning and tolerancing per ASME Y14.5M.
2. This drawing is subject to change without notice.
3. This dimension does not include mold flash, protrusions, or gate burrs. Mold flash, protrusions, or gate burrs shall not exceed 0.15 mm per side.
4. This dimension does not include interlead flash. Interlead flash shall not exceed 0.25 mm per side.

# EXAMPLE BOARD LAYOUT

DCT0008A

SSOP - 1.3 mm max height

SMALL OUTLINE PACKAGE

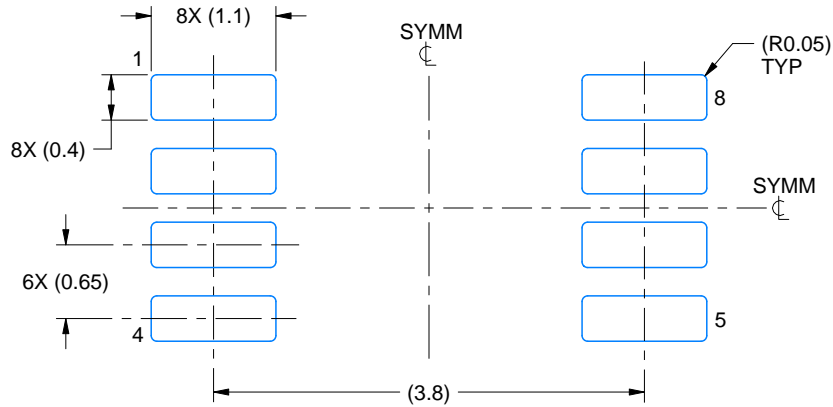

LAND PATTERN EXAMPLE  
EXPOSED METAL SHOWN  
SCALE:15X

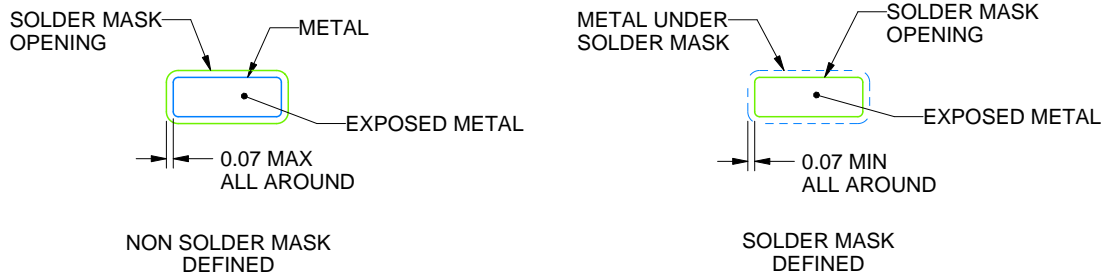

SOLDER MASK DETAILS

4220784/D 10/2025

NOTES: (continued)

- 5. Publication IPC-7351 may have alternate designs.
- 6. Solder mask tolerances between and around signal pads can vary based on board fabrication site.

# EXAMPLE STENCIL DESIGN

DCT0008A

SSOP - 1.3 mm max height

SMALL OUTLINE PACKAGE

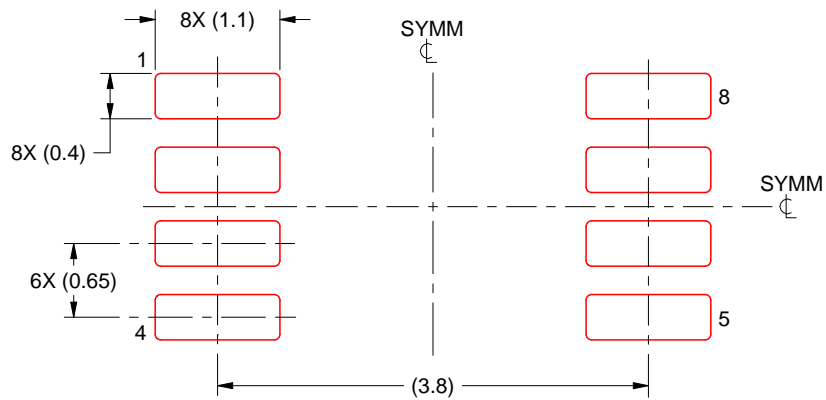

SOLDER PASTE EXAMPLE  
BASED ON 0.125 mm THICK STENCIL  
SCALE:15X

4220784/D 10/2025

NOTES: (continued)

7. Laser cutting apertures with trapezoidal walls and rounded corners may offer better paste release. IPC-7525 may have alternate design recommendations.
8. Board assembly site may have different recommendations for stencil design.

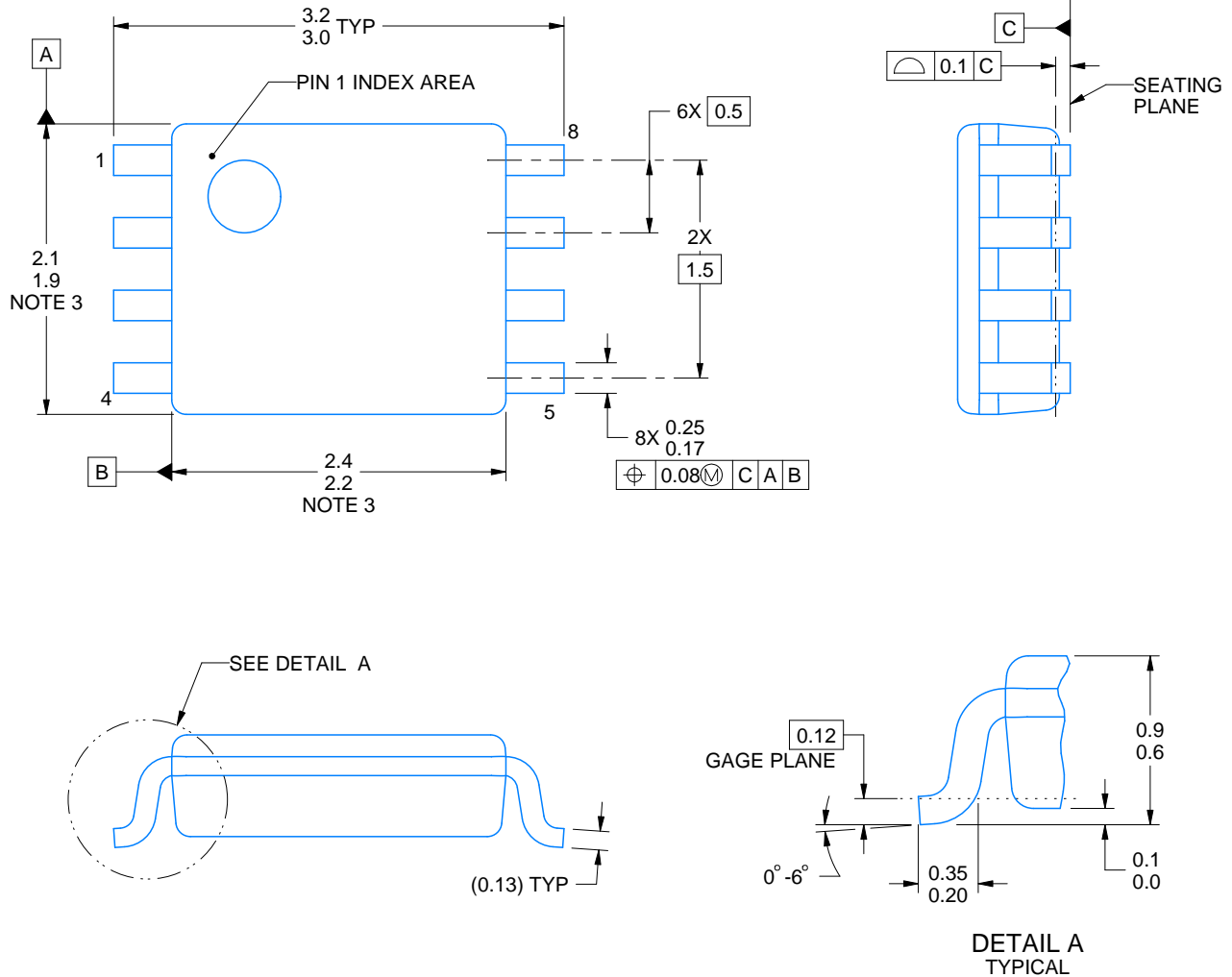

4225266/A 09/2014

NOTES:

1. All linear dimensions are in millimeters. Any dimensions in parenthesis are for reference only. Dimensioning and tolerancing per ASME Y14.5M.
2. This drawing is subject to change without notice.
3. This dimension does not include mold flash, protrusions, or gate burrs. Mold flash, protrusions, or gate burrs shall not exceed 0.15 mm per side.
4. Reference JEDEC registration MO-187 variation CA.

# EXAMPLE BOARD LAYOUT

DCU0008A

VSSOP - 0.9 mm max height

SMALL OUTLINE PACKAGE

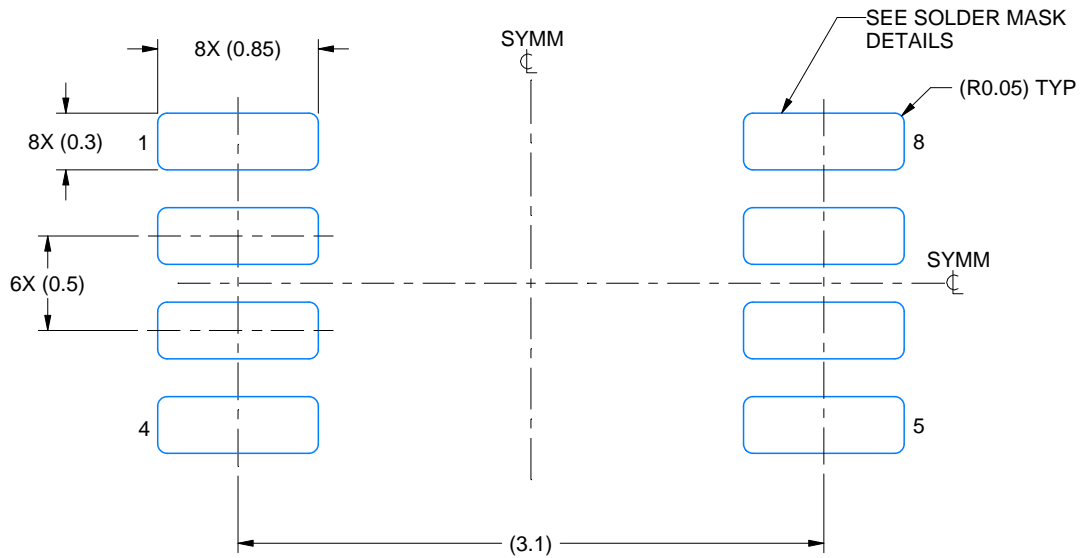

LAND PATTERN EXAMPLE  
EXPOSED METAL SHOWN  
SCALE: 25X

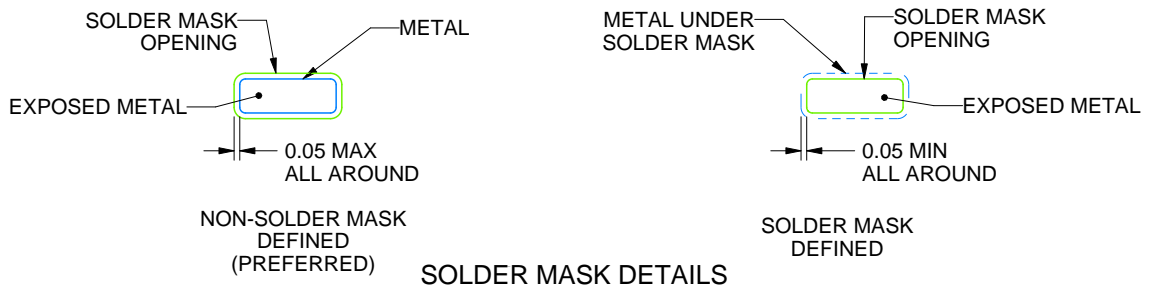

4225266/A 09/2014

NOTES: (continued)

- 5. Publication IPC-7351 may have alternate designs.
- 6. Solder mask tolerances between and around signal pads can vary based on board fabrication site.

# EXAMPLE STENCIL DESIGN

DCU0008A

VSSOP - 0.9 mm max height

SMALL OUTLINE PACKAGE

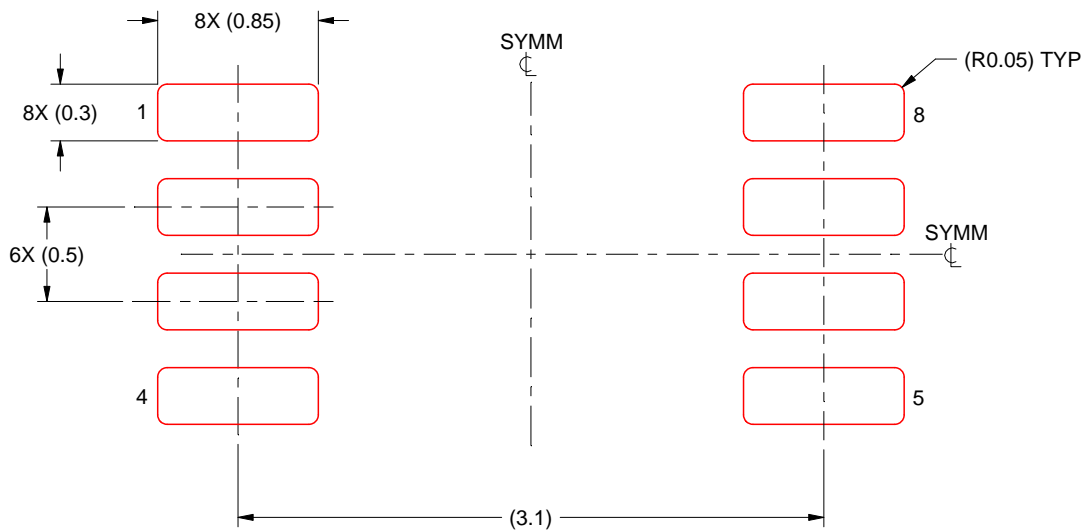

SOLDER PASTE EXAMPLE  
BASED ON 0.125 mm THICK STENCIL  
SCALE: 25X

4225266/A 09/2014

NOTES: (continued)

7. Laser cutting apertures with trapezoidal walls and rounded corners may offer better paste release. IPC-7525 may have alternate design recommendations.
8. Board assembly site may have different recommendations for stencil design.

## IMPORTANT NOTICE AND DISCLAIMER

TI PROVIDES TECHNICAL AND RELIABILITY DATA (INCLUDING DATASHEETS), DESIGN RESOURCES (INCLUDING REFERENCE DESIGNS), APPLICATION OR OTHER DESIGN ADVICE, WEB TOOLS, SAFETY INFORMATION, AND OTHER RESOURCES "AS IS" AND WITH ALL FAULTS, AND DISCLAIMS ALL WARRANTIES, EXPRESS AND IMPLIED, INCLUDING WITHOUT LIMITATION ANY IMPLIED WARRANTIES OF MERCHANTABILITY, FITNESS FOR A PARTICULAR PURPOSE OR NON-INFRINGEMENT OF THIRD PARTY INTELLECTUAL PROPERTY RIGHTS.

These resources are intended for skilled developers designing with TI products. You are solely responsible for (1) selecting the appropriate TI products for your application, (2) designing, validating and testing your application, and (3) ensuring your application meets applicable standards, and any other safety, security, regulatory or other requirements.

These resources are subject to change without notice. TI grants you permission to use these resources only for development of an application that uses the TI products described in the resource. Other reproduction and display of these resources is prohibited. No license is granted to any other TI intellectual property right or to any third party intellectual property right. TI disclaims responsibility for, and you fully indemnify TI and its representatives against any claims, damages, costs, losses, and liabilities arising out of your use of these resources.

TI's products are provided subject to [TI's Terms of Sale](#), [TI's General Quality Guidelines](#), or other applicable terms available either on [ti.com](http://ti.com) or provided in conjunction with such TI products. TI's provision of these resources does not expand or otherwise alter TI's applicable warranties or warranty disclaimers for TI products. Unless TI explicitly designates a product as custom or customer-specified, TI products are standard, catalog, general purpose devices.

TI objects to and rejects any additional or different terms you may propose.

Copyright © 2026, Texas Instruments Incorporated

Last updated 10/2025

## Looking for pricing, stock, or lifecycle information?

Click below to explore more details on WIN SOURCE:

 [View P4FL15A\\_R1\\_00001 on WIN SOURCE](#)

 [Panjit Information](#)

## Optimize Your Supply Chain with WIN SOURCE Solutions

-  Global Sourcing Solution
-  Obsolete Management
-  Cost Control Management
-  Shortage Management
-  Alternative Solution
-  Excess Inventory Management