



# THE DATASHEET OF OPA892DR



# OPAx892 2GHz, 10V/V Stable, 0.95nV/√Hz, Ultra-Low THD Operational Amplifiers

## 1 Features

- Ultra-low 0.95nV/√Hz voltage noise
- High speed:
  - 2GHz gain-bandwidth product
  - 700V/μs slew rate
  - 30ns settling time (0.1%)
- Stable at gains ≥10V/V
- Output drive, I<sub>O</sub> = 200mA (typical)
- Very low distortion:
  - THD = –78dBc (f = 1MHz, R<sub>L</sub> = 150Ω)
  - THD+N = –114dBc (f = 1kHz, BW = 80kHz)
- Wide range of power supplies:
  - V<sub>CC</sub> = ±4.5V to ±18V
- Offset nulling pins on the OPA892

## 2 Applications

- [Ultrasound scanner](#)
- [Source measurement unit \(SMU\)](#)
- [Power quality meter](#)
- [Ultrasound scanner](#)
- [Vector signal transceiver \(VST\)](#)
- [Professional audio mixer or control surface](#)
- [Professional microphones and wireless systems](#)
- [Professional speaker systems](#)
- [Professional audio amplifier](#)
- [Soundbar](#)
- [Turntable](#)
- [Professional video camera](#)
- [Guitar and other instrument amplifier](#)
- [Data acquisition \(DAQ\)](#)

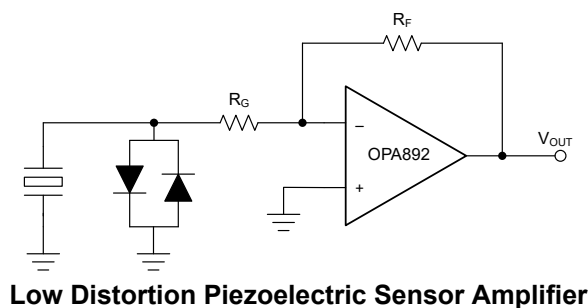

## 3 Description

The OPA892 and OPA2892 (OPAx892) are ultra-low voltage noise, high-speed voltage-feedback amplifiers that are an excellent choice for applications requiring low voltage noise, including communication and imaging. The single-amplifier OPA892 and the dual-amplifier OPA2892 offer very good ac performance with a 290MHz bandwidth, a 700V/μs slew rate, and a 30ns settling time (0.1%) for a gain of 10V/V. The OPAx892 are stable at gains of 10 or greater and –9 or less. These amplifiers have a high drive capability of 200mA and draw only 7.5mA of supply current per amplifier. With a total harmonic distortion (THD) of –68dBc at f = 1MHz, the OPAx892 are designed for applications requiring low distortion. Because the distortion remains low over a wide range of output voltages, the OPAx892 is useful in large dynamic-range applications such as imaging, sonar, and audio.

### Device Information

PART NUMBER	AMPLIFIERS	PACKAGE <sup>(1)</sup>	PACKAGE SIZE <sup>(2)</sup>
OPA892	One	D (SOIC, 8)	4.9mm × 6mm
OPA2892	Two	DGN (HVSSOP, 8)	3mm × 4.9mm

- (1) For more information, see [Section 10](#).
- (2) The package size (length × width) is a nominal value and includes pins, where applicable.

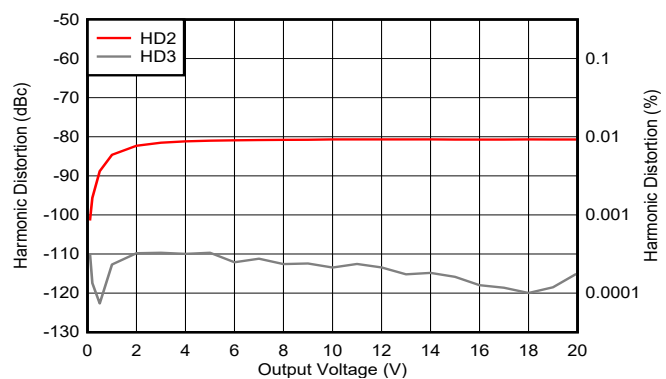

**Harmonic Distortion vs Peak-to-peak Output Voltage**



## Table of Contents

<b>1 Features</b> .....	<b>1</b>	<b>7 Application and Implementation</b> .....	<b>16</b>
<b>2 Applications</b> .....	<b>1</b>	7.1 Application Information.....	16
<b>3 Description</b> .....	<b>1</b>	7.2 Typical Application.....	17
<b>4 Pin Configuration and Functions</b> .....	<b>3</b>	7.3 Power Supply Recommendations.....	19
<b>5 Specifications</b> .....	<b>4</b>	7.4 Layout.....	19
5.1 Absolute Maximum Ratings.....	4	<b>8 Device and Documentation Support</b> .....	<b>23</b>
5.2 ESD Ratings.....	4	8.1 Documentation Support.....	23
5.3 Recommended Operating Conditions.....	4	8.2 Receiving Notification of Documentation Updates.....	23
5.4 Thermal Information.....	4	8.3 Support Resources.....	23
5.5 Electrical Characteristics.....	5	8.4 Trademarks.....	23
5.6 Typical Characteristics.....	7	8.5 Electrostatic Discharge Caution.....	23
<b>6 Detailed Description</b> .....	<b>14</b>	8.6 Glossary.....	23
6.1 Overview.....	14	<b>9 Revision History</b> .....	<b>23</b>
6.2 Functional Block Diagram.....	14	<b>10 Mechanical, Packaging, and Orderable Information</b> .....	<b>24</b>
6.3 Feature Description.....	15		
6.4 Device Functional Modes.....	15		

## 4 Pin Configuration and Functions

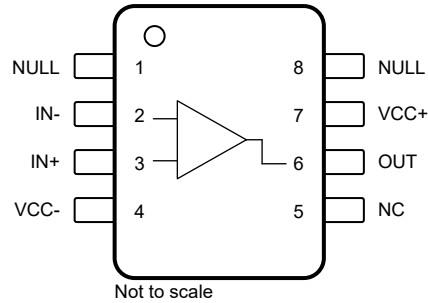

**Figure 4-1. OPA892: D Package, 8-Pin SOIC (Top View)**

**Table 4-1. Pin Functions: OPA892**

PIN		TYPE	DESCRIPTION
NAME	NO.		
IN-	2	Input	Inverting input
IN+	3	Input	Noninverting input
NC	5	—	No connection
NULL	1, 8	Input	Voltage offset adjust
OUT	6	Output	Output of amplifier
VCC-	4	—	Negative power supply
VCC+	7	—	Positive power supply

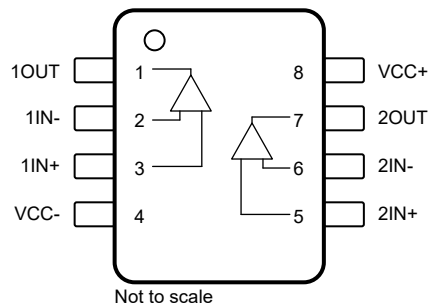

**Figure 4-2. OPA2892: DGN Package, 8-pin HVSSOP (Top View)**

**Table 4-2. Pin Functions: OPA2892**

PIN		TYPE	DESCRIPTION
NAME	NO.		
1IN-	2	Input	Channel 1 inverting input
1IN+	3	Input	Channel 1 noninverting input
1OUT	1	Output	Channel 1 output
2IN-	6	Input	Channel 2 inverting input
2IN+	5	Input	Channel 2 noninverting input
2OUT	7	Output	Channel 2 output
VCC-	4	—	Negative power supply
VCC+	8	—	Positive power supply
Thermal pad		—	Thermal pad. DGN (HVSSOP) package only. For best thermal performance, connect pad to large copper plane. Thermal pad can be connected to any pin on the device, or any other potential on the board if voltage on thermal pad remains between VCC+ and VCC-.

## 5 Specifications

### 5.1 Absolute Maximum Ratings

over operating free-air temperature range (unless otherwise noted)<sup>(1)</sup>

		MIN	MAX	UNIT
V <sub>CC</sub>	Supply voltage, V <sub>CC+</sub> – V <sub>CC-</sub>		37	V
V <sub>I</sub>	Input voltage		±V <sub>CC</sub>	V
I <sub>O</sub>	Output current <sup>(2)</sup>		240	mA
V <sub>IO</sub>	Differential input voltage		±1.5	V
I <sub>IN</sub>	Continuous input current		10	mA
T <sub>J</sub>	Junction temperature	Any condition	150	°C
		Continuous operation, long-term reliability <sup>(3)</sup>	125	
T <sub>stg</sub>	Storage temperature	–65	150	°C

- (1) Operation outside the *Absolute Maximum Ratings* may cause permanent device damage. *Absolute Maximum Ratings* do not imply functional operation of the device at these or any other conditions beyond those listed under *Recommended Operating Conditions*. If used outside the *Recommended Operating Conditions* but within the *Absolute Maximum Ratings*, the device may not be fully functional, and this may affect device reliability, functionality, performance, and shorten the device lifetime.
- (2) When continuously operating at any output current, do not exceed the maximum junction temperature. Keep the output current less than the absolute maximum rating regardless of time interval.
- (3) The maximum junction temperature for continuous operation is limited by package constraints. Operation greater than this temperature can result in reduced reliability, lifetime of the device, or both.

### 5.2 ESD Ratings

			VALUE	UNIT
V <sub>(ESD)</sub>	Electrostatic discharge	Human body model (HBM), per ANSI/ESDA/JEDEC JS-001, all pins <sup>(1)</sup>	±4000	V
		Charged device model (CDM), per ANSI/ESDA/JEDEC JS-002, all pins <sup>(2)</sup>	±1500	

- (1) JEDEC document JEP155 states that 500-V HBM allows safe manufacturing with a standard ESD control process.
- (2) JEDEC document JEP157 states that 250-V CDM allows safe manufacturing with a standard ESD control process.

### 5.3 Recommended Operating Conditions

over operating free-air temperature range (unless otherwise noted)

			MIN	NOM	MAX	UNIT
V <sub>CC</sub>	Supply voltage	Dual-supply	±4.5	±15	±18	V
		Single-supply	9	30	36	
T <sub>A</sub>	Operating free-air temperature		–40	25	85	°C

### 5.4 Thermal Information

THERMAL METRIC <sup>(1)</sup>		OPA892	OPA2892	UNIT
		D (SOIC)	DGN (HVSSOP)	
		8 PINS	8 PINS	
R <sub>θJA</sub>	Junction-to-ambient thermal resistance	124.5	52	°C/W
R <sub>θJC(top)</sub>	Junction-to-case (top) thermal resistance	65.0	75.2	°C/W
R <sub>θJB</sub>	Junction-to-board thermal resistance	72.2	24.5	°C/W
Ψ <sub>JT</sub>	Junction-to-top characterization parameter	13.6	4	°C/W
Ψ <sub>JB</sub>	Junction-to-board characterization parameter	71.4	24.5	°C/W
R <sub>θJC(bot)</sub>	Junction-to-case (bottom) thermal resistance	N/A	9.1	°C/W

- (1) For information about traditional and new thermal metrics, see the [Semiconductor and IC Package Thermal Metrics](#) application report.

## 5.5 Electrical Characteristics

at  $T_A = 25^\circ\text{C}$ ,  $V_{CC} = \pm 15\text{ V}$ , and  $R_L = 150\ \Omega$  (unless otherwise noted)

PARAMETER		TEST CONDITIONS		MIN	TYP	MAX	UNIT	
<b>DYNAMIC PERFORMANCE</b>								
BW	Small-signal bandwidth (-3 dB)	Gain = 10	$V_{CC} = \pm 15\text{ V}$		290		MHz	
			$V_{CC} = \pm 5\text{ V}$		250			
		Gain = 20	$V_{CC} = \pm 15\text{ V}$		110			
			$V_{CC} = \pm 5\text{ V}$		100			
	Bandwidth for 0.1-dB flatness	Gain = 10	$V_{CC} = \pm 15\text{ V}$		17			
			$V_{CC} = \pm 5\text{ V}$		17			
Full power bandwidth <sup>(1)</sup>	$V_{O(PP)} = 20\text{ V}$ , $V_{CC} = \pm 15\text{ V}$			11.1				
	$V_{O(PP)} = 5\text{ V}$ , $V_{CC} = \pm 5\text{ V}$			31.8				
SR	Slew rate <sup>(2)</sup>	Gain = 10	$V_{CC} = \pm 15\text{ V}$ , 20-V step		700		V/ $\mu\text{s}$	
			$V_{CC} = \pm 5\text{ V}$ , 5-V step		500			
$t_s$	Settling time to 0.1%	Gain = -10	$V_{CC} = \pm 15\text{ V}$ , 5-V step		22		ns	
			$V_{CC} = \pm 5\text{ V}$ , 2-V step		22			
	Settling time to 0.01%	Gain = -10	$V_{CC} = \pm 15\text{ V}$ , 5-V step		160			
			$V_{CC} = \pm 5\text{ V}$ , 2-V step		160			
<b>AUDIO PERFORMANCE</b>								
THD+N	Total harmonic distortion + noise	Gain = 10, $f = 1\text{ kHz}$ , BW = 80 kHz	$V_{CC} = \pm 15\text{ V}$ , $R_L = 600\ \Omega$ , $V_O = 3\text{ V}_{RMS}$		-114		dB	
					0.0002		%	
			$V_{CC} = \pm 15\text{ V}$ , $R_L = 2\text{ k}\Omega$ , $V_O = 3\text{ V}_{RMS}$		-114		dB	
					0.0002		%	
			$V_{CC} = \pm 5\text{ V}$ , $R_L = 600\ \Omega$ , $V_O = 1\text{ V}_{RMS}$		-106		dB	
					0.0005		%	
IMD	Intermodulation distortion	Gain = 10, SMPTE/DIN two-tone, 4:1 (60 Hz and 7 kHz)	$V_{CC} = \pm 15\text{ V}$ , $V_O = 3\text{ V}_{RMS}$ , $R_L = 600\ \Omega$		-109		dB	
					0.00036		%	
			$V_{CC} = \pm 15\text{ V}$ , $V_O = 3\text{ V}_{RMS}$ , $R_L = 2\text{ k}\Omega$		-109		dB	
					0.00036		%	
			$V_{CC} = \pm 5\text{ V}$ , $V_O = 1\text{ V}_{RMS}$ , $R_L = 600\ \Omega$		-105		dB	
					0.00056		%	
			$V_{CC} = \pm 5\text{ V}$ , $V_O = 1\text{ V}_{RMS}$ , $R_L = 2\text{ k}\Omega$		-105		dB	
					0.00056		%	
<b>NOISE AND DISTORTION PERFORMANCE</b>								
THD	Total harmonic distortion	$V_{O(PP)} = 2\text{ V}$ , $f = 1\text{ MHz}$ , gain = 10, $V_{CC} = \pm 15\text{ V}$	$R_L = 1\text{ k}\Omega$		-78		dBc	
					-86			
			$V_{O(PP)} = 2\text{ V}$ , $f = 1\text{ MHz}$ , gain = 10, $V_{CC} = \pm 5\text{ V}$	$R_L = 1\text{ k}\Omega$		-77		
						-85		
$V_n$	Input voltage noise	$V_{CC} = \pm 5\text{ V}$ or $\pm 15\text{ V}$ , $f > 10\text{ kHz}$		0.95		nV/ $\sqrt{\text{Hz}}$		
$I_n$	Input current noise	$V_{CC} = \pm 5\text{ V}$ or $\pm 15\text{ V}$ , $f > 10\text{ kHz}$		2.3		pA/ $\sqrt{\text{Hz}}$		
$X_T$	Channel-to-channel crosstalk (OPA2892 only)	$V_{CC} = \pm 5\text{ V}$ or $\pm 15\text{ V}$ , $f = 1\text{ MHz}$		-54		dBc		

## 5.5 Electrical Characteristics (continued)

at  $T_A = 25^\circ\text{C}$ ,  $V_{CC} = \pm 15\text{ V}$ , and  $R_L = 150\ \Omega$  (unless otherwise noted)

PARAMETER		TEST CONDITIONS		MIN	TYP	MAX	UNIT
<b>DC PERFORMANCE</b>							
	Open-loop gain	$V_{CC} = \pm 15\text{ V}$ , $V_O = \pm 10\text{ V}$ , $R_L = 1\text{ k}\Omega$	$T_A = 25^\circ\text{C}$	93	100		dB
			$T_A = \text{full range}$	92			dB
		$V_{CC} = \pm 5\text{ V}$ , $V_O = \pm 2.5\text{ V}$ , $R_L = 1\text{ k}\Omega$	$T_A = 25^\circ\text{C}$	92	98		dB
			$T_A = \text{full range}$	91			dB
$V_{OS}$	Input offset voltage	$V_{CC} = \pm 5\text{ V}$ or $\pm 15\text{ V}$ , $T_A = 25^\circ\text{C}$			0.2	1	mV
	Offset voltage drift	$V_{CC} = \pm 5\text{ V}$ or $\pm 15\text{ V}$ , $T_A = \text{full range}$			1		$\mu\text{V}/^\circ\text{C}$
$I_{IB}$	Input bias current	$V_{CC} = \pm 5\text{ V}$ or $\pm 15\text{ V}$	$T_A = 25^\circ\text{C}$		9	20	$\mu\text{A}$
			$T_A = \text{full range}$			33	$\mu\text{A}$
$I_{OS}$	Input offset current	$V_{CC} = \pm 5\text{ V}$ or $\pm 15\text{ V}$	$T_A = 25^\circ\text{C}$		30	250	nA
			$T_A = \text{full range}$			400	nA
	Input offset current drift	$V_{CC} = \pm 5\text{ V}$ or $\pm 15\text{ V}$ , $T_A = \text{full range}$			0.2		$\text{nA}/^\circ\text{C}$
<b>INPUT CHARACTERISTICS</b>							
$V_{ICR}$	Common-mode input voltage	$V_{CC} = \pm 15\text{ V}$		$\pm 13.8$	$\pm 14.3$		V
		$V_{CC} = \pm 5\text{ V}$		$\pm 3.8$	$\pm 4.3$		
CMRR	Common-mode rejection ratio	$V_{CC} = \pm 15\text{ V}$ , $V_{ICR} = \pm 12\text{ V}$	$T_A = 25^\circ\text{C}$	85	104		dB
			$T_A = \text{full range}$	80			
		$V_{CC} = \pm 5\text{ V}$ , $V_{ICR} = \pm 2.5\text{ V}$	$T_A = 25^\circ\text{C}$	90	106		
			$T_A = \text{full range}$	85			
	Input impedance	Common-mode		10    1.2			$\text{M}\Omega$    pF
		Differential-mode		6    1.8			$\text{k}\Omega$    pF
<b>OUTPUT CHARACTERISTICS</b>							
$V_O$	Output voltage swing	$V_{CC} = \pm 15\text{ V}$ , $R_L = 250\ \Omega$		$\pm 12$	$\pm 12.9$		V
		$V_{CC} = \pm 5\text{ V}$ , $R_L = 150\ \Omega$		$\pm 3$	$\pm 3.5$		
		$V_{CC} = \pm 15\text{ V}$ , $R_L = 1\text{ k}\Omega$		$\pm 13$	$\pm 13.6$		
		$V_{CC} = \pm 5\text{ V}$ , $R_L = 1\text{ k}\Omega$		$\pm 3.4$	$\pm 3.8$		
$I_O$	Output current	$R_L = 10\ \Omega$	$V_{CC} = \pm 15\text{ V}$	160	200		mA
			$V_{CC} = \pm 5\text{ V}$	120	160		
$R_O$	Output resistance <sup>(3)</sup>	Open-loop			8		$\Omega$
<b>POWER SUPPLY</b>							
$I_{CC}$	Supply current (per amplifier)	$V_{CC} = \pm 15\text{ V}$	$T_A = 25^\circ\text{C}$		7.5	10	mA
			$T_A = \text{full range}$			11	
		$V_{CC} = \pm 5\text{ V}$	$T_A = 25^\circ\text{C}$		9		
			$T_A = \text{full range}$		6.5	10	
PSRR	Power-supply rejection ratio	$V_{CC} = \pm 5\text{ V}$ or $\pm 15\text{ V}$	$T_A = 25^\circ\text{C}$	90	105		dB
			$T_A = \text{full range}$	85			

(1) Full-power bandwidth = slew rate /  $[\pi V_{O(P-P)}]$ .

(2) Slew rate is measured from an output level range of 25% to 75%.

(3) Keep junction temperature less than the absolute maximum rating when the output is heavily loaded or shorted; see also [Section 5.1](#).

## 5.6 Typical Characteristics

at  $T_A = 25^\circ\text{C}$ ,  $V_{CC} = \pm 15\text{ V}$ , gain = +10 V/V,  $R_L = 150\ \Omega$ , and  $R_F = 220\ \Omega$  (unless otherwise noted)

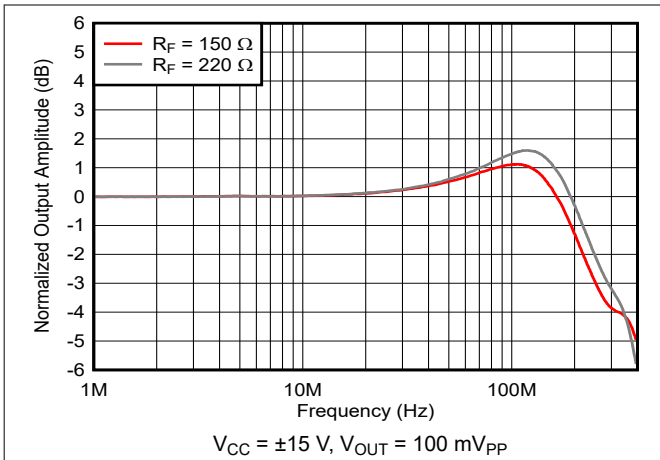

**Figure 5-1. Frequency Response vs Feedback Resistance**

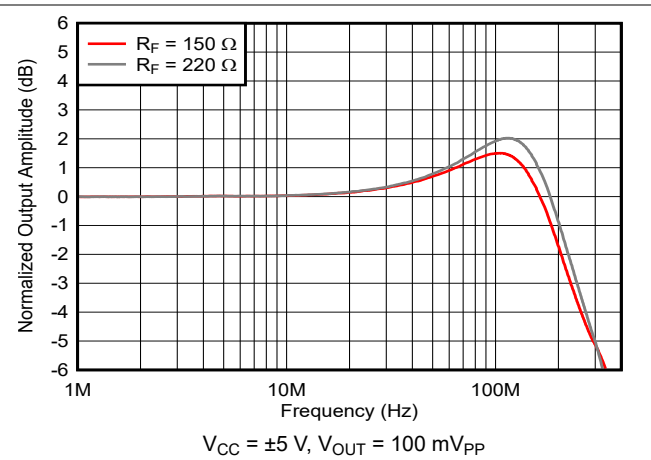

**Figure 5-2. Frequency Response vs Feedback Resistance**

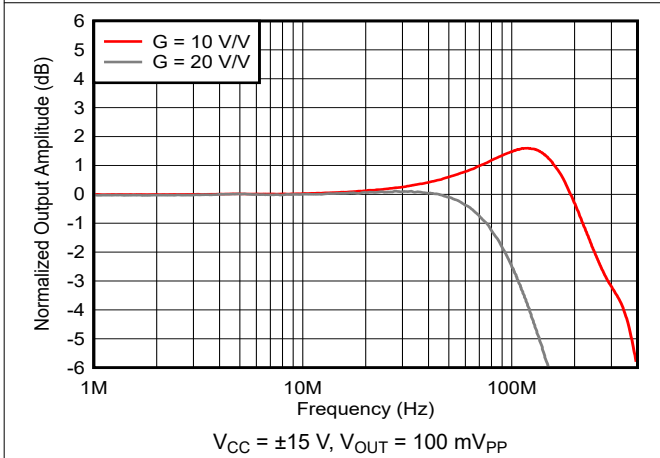

**Figure 5-3. Frequency Response vs Gain**

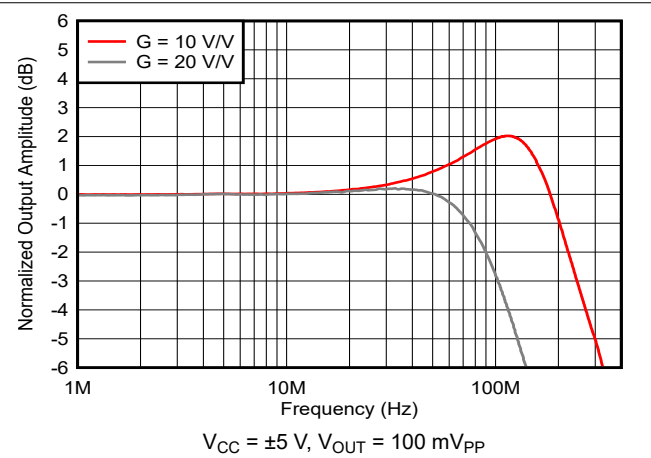

**Figure 5-4. Frequency Response vs Gain**

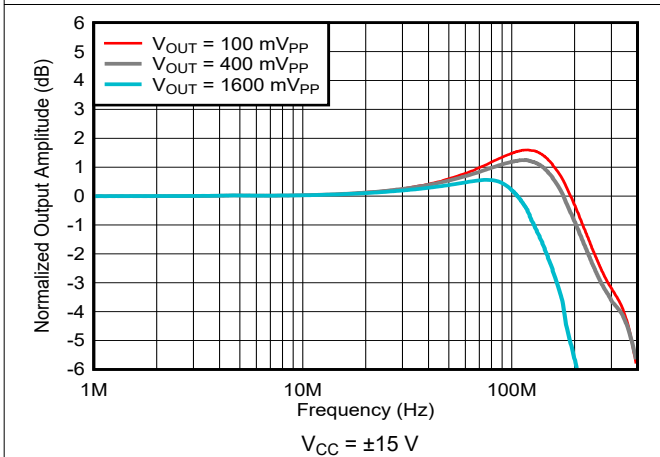

**Figure 5-5. Large-signal Frequency Response**

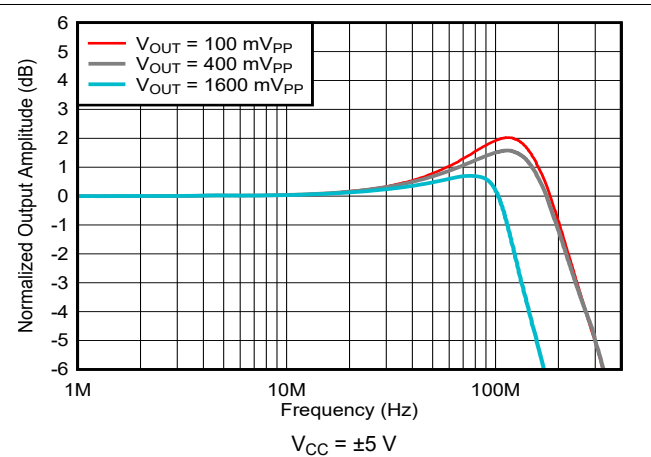

**Figure 5-6. Large-signal Frequency Response**

### 5.6 Typical Characteristics (continued)

at  $T_A = 25^\circ\text{C}$ ,  $V_{CC} = \pm 15\text{ V}$ , gain = +10 V/V,  $R_L = 150\ \Omega$ , and  $R_F = 220\ \Omega$  (unless otherwise noted)

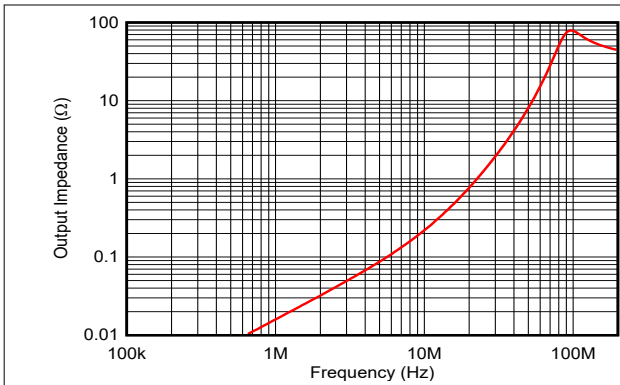

Figure 5-7. Closed-loop Output Impedance

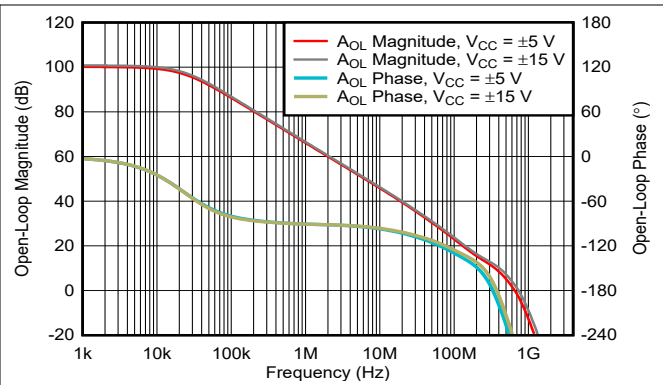

Figure 5-8. Open-loop Gain and Phase Response

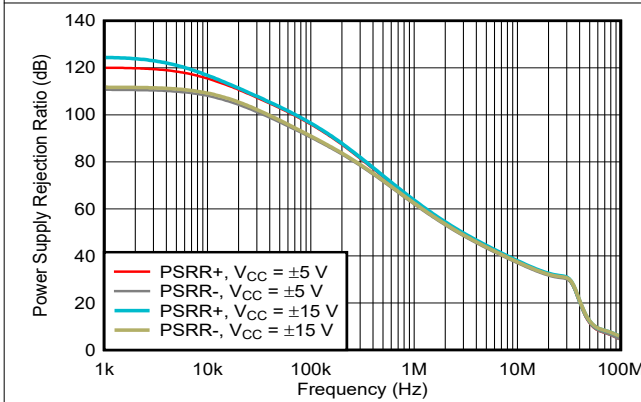

Figure 5-9. Power-Supply Rejection Ratio vs Frequency

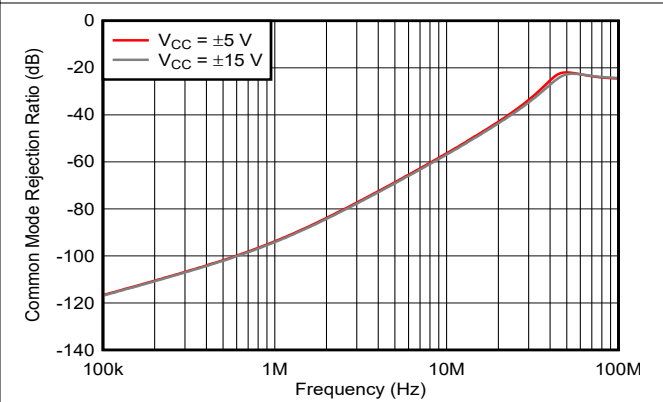

Figure 5-10. Common-mode Rejection Ratio vs Frequency

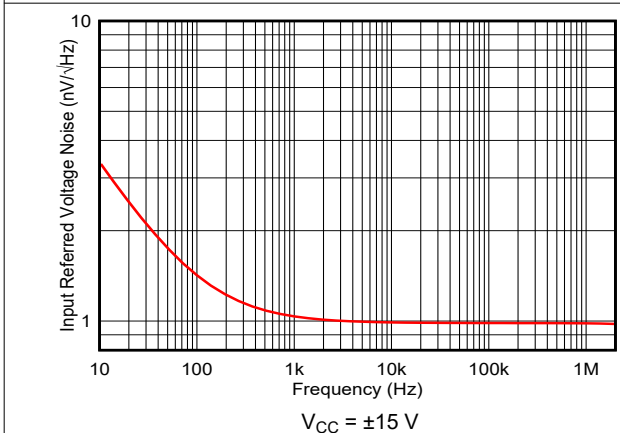

Figure 5-11. Input-referred Voltage Noise vs Frequency

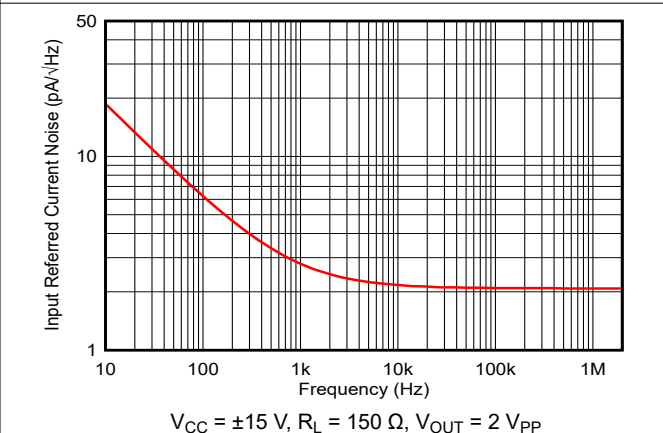
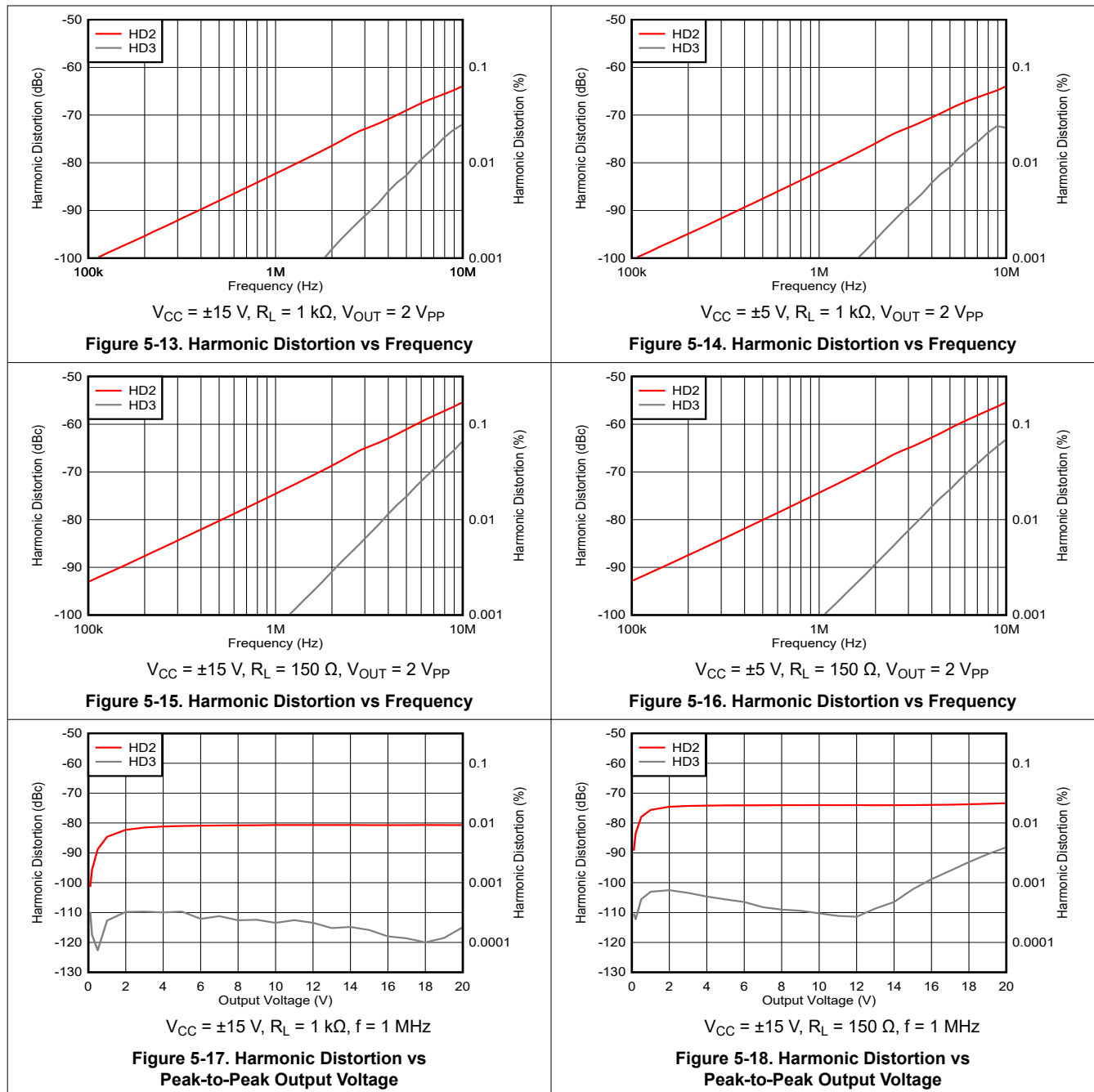

Figure 5-12. Input-referred Current Noise vs Frequency

### 5.6 Typical Characteristics (continued)

at  $T_A = 25^\circ\text{C}$ ,  $V_{CC} = \pm 15\text{ V}$ , gain = +10 V/V,  $R_L = 150\ \Omega$ , and  $R_F = 220\ \Omega$  (unless otherwise noted)



### 5.6 Typical Characteristics (continued)

at  $T_A = 25^\circ\text{C}$ ,  $V_{CC} = \pm 15\text{ V}$ , gain = +10 V/V,  $R_L = 150\ \Omega$ , and  $R_F = 220\ \Omega$  (unless otherwise noted)

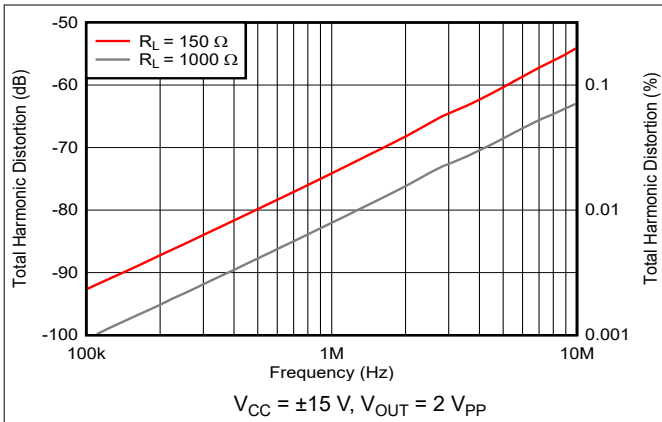

**Figure 5-19. Total Harmonic Distortion vs Frequency**

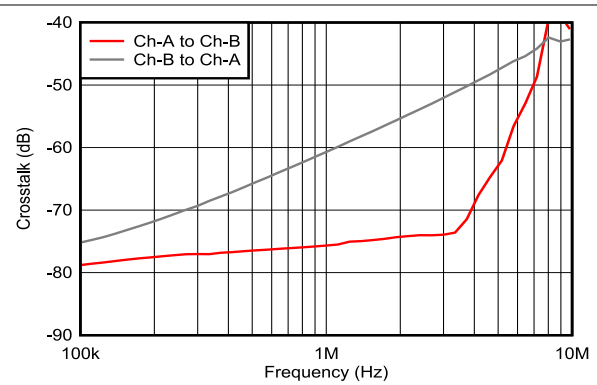

**Figure 5-20. OPA2892 Crosstalk vs Frequency**

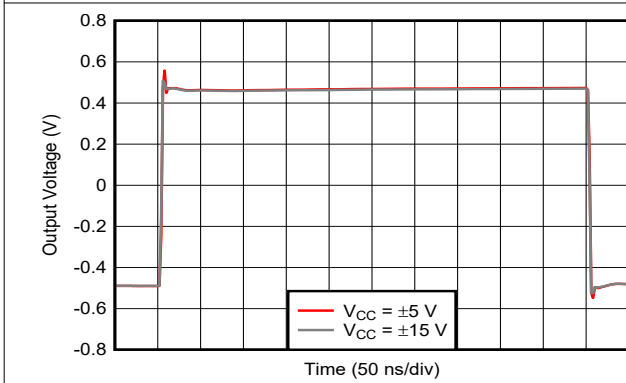

**Figure 5-21. 1-V Step Response**

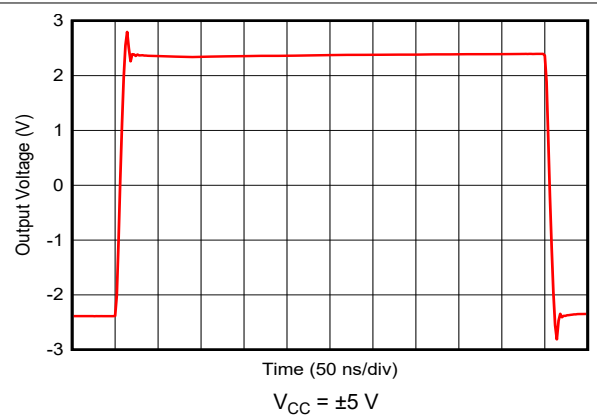

**Figure 5-22. 5-V Step Response**

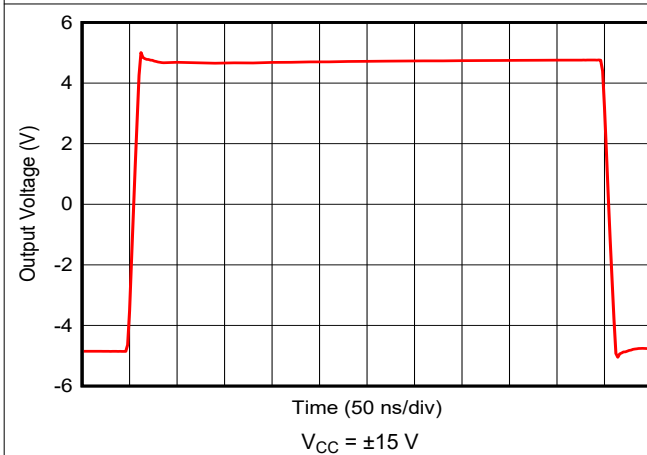

**Figure 5-23. 10-V Step Response**

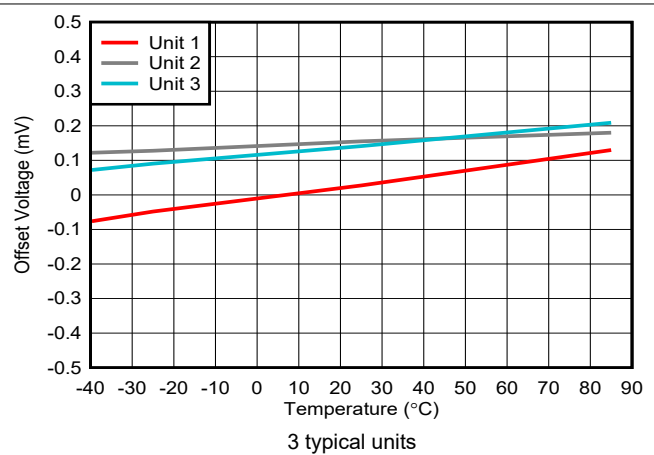

**Figure 5-24. Input Offset Voltage vs Ambient Temperature**

### 5.6 Typical Characteristics (continued)

at  $T_A = 25^\circ\text{C}$ ,  $V_{CC} = \pm 15\text{ V}$ , gain = +10 V/V,  $R_L = 150\ \Omega$ , and  $R_F = 220\ \Omega$  (unless otherwise noted)

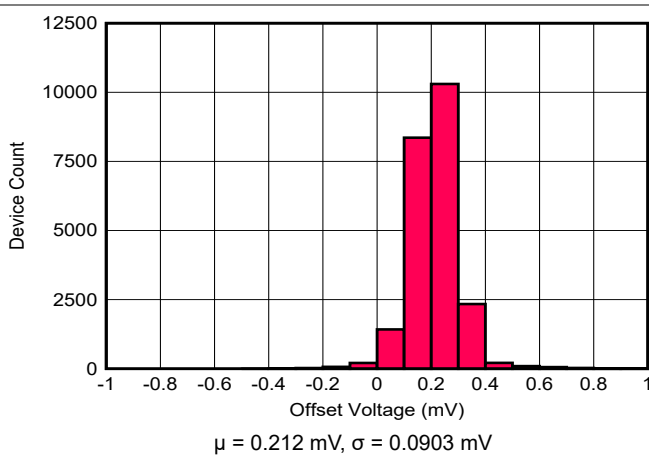

Figure 5-25. Voltage Offset Distribution

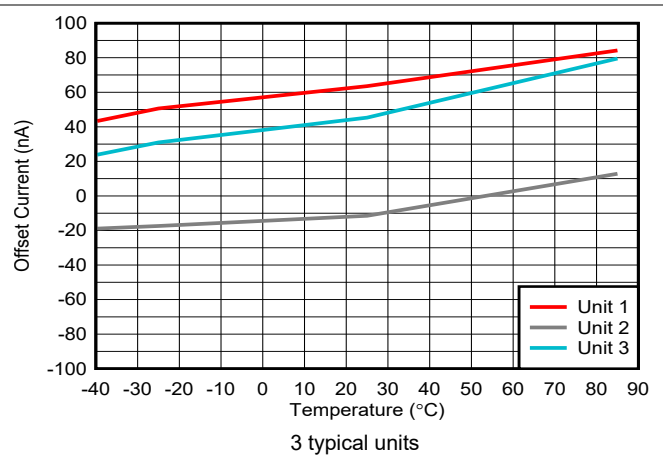

Figure 5-26. Input Offset Current vs Ambient Temperature

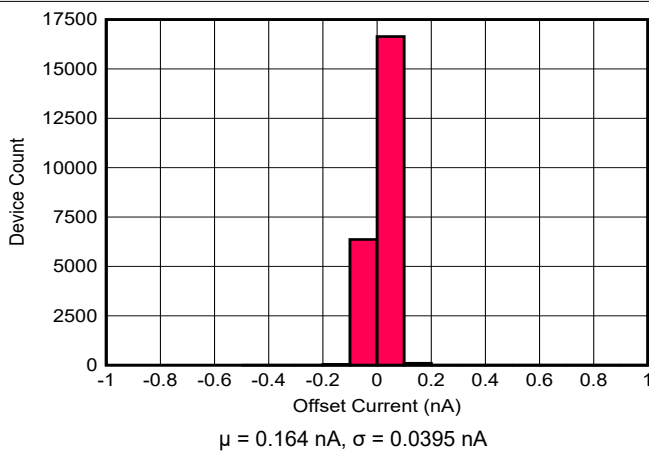

Figure 5-27. Input Offset Current vs Ambient Temperature

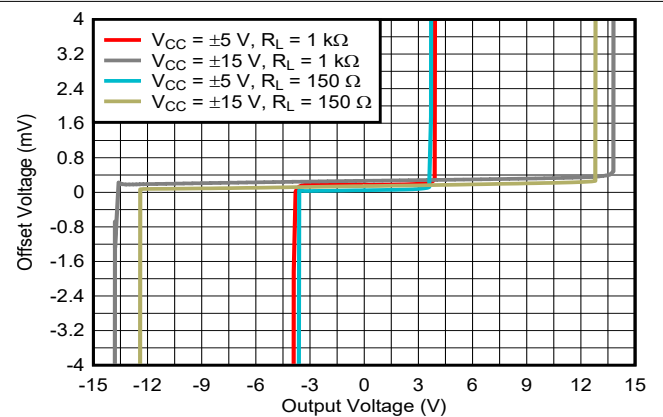

Figure 5-28. Offset Voltage vs Output Voltage

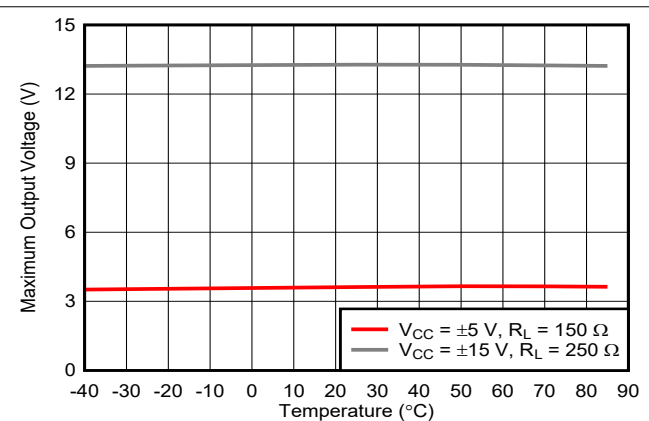

Figure 5-29. Maximum Output Voltage Swing vs Ambient Temperature

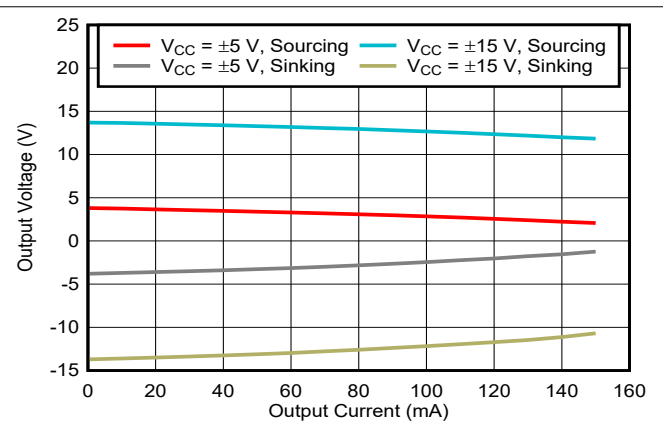
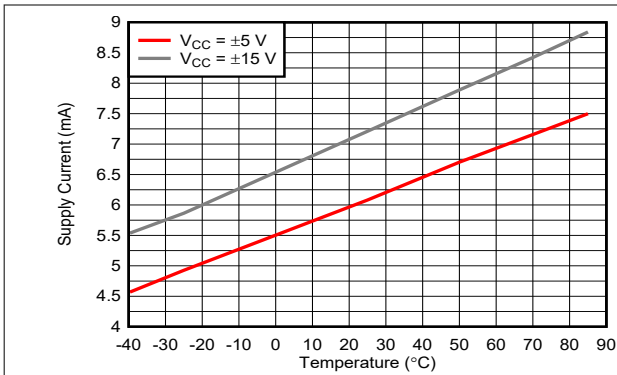

Figure 5-30. Output Swing vs Load Current

### 5.6 Typical Characteristics (continued)

at  $T_A = 25^\circ\text{C}$ ,  $V_{CC} = \pm 15\text{ V}$ , gain = +10 V/V,  $R_L = 150\ \Omega$ , and  $R_F = 220\ \Omega$  (unless otherwise noted)



**Figure 5-31. Supply Current vs Ambient Temperature**

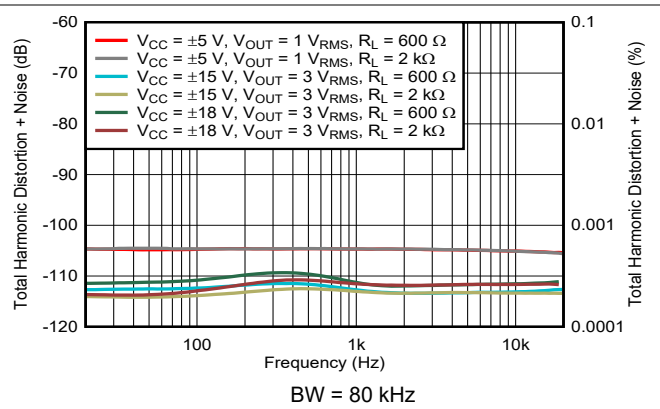

**Figure 5-32. THD+N vs Frequency**

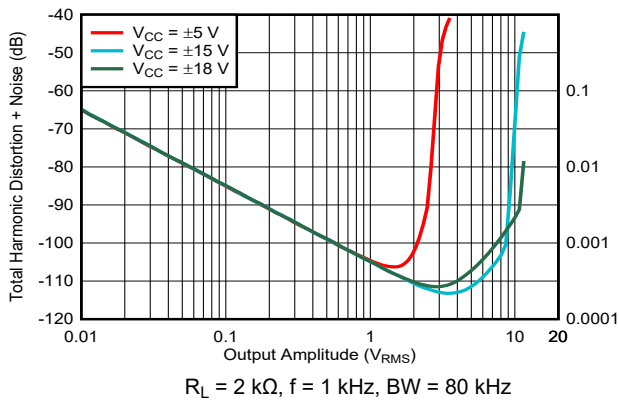

**Figure 5-33. THD+N Ratio vs Output Amplitude**

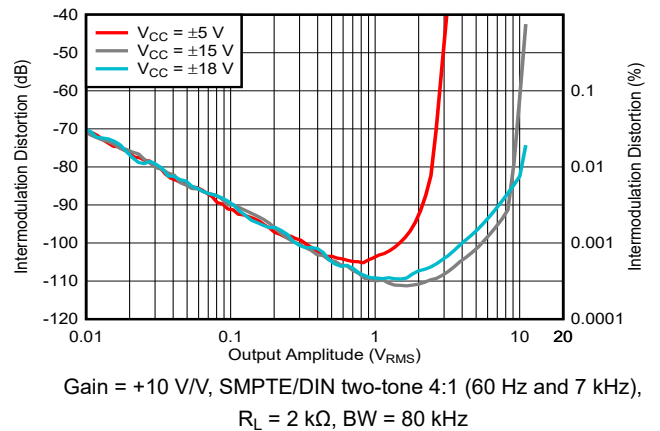

**Figure 5-34. Intermodulation Distortion vs Amplitude**

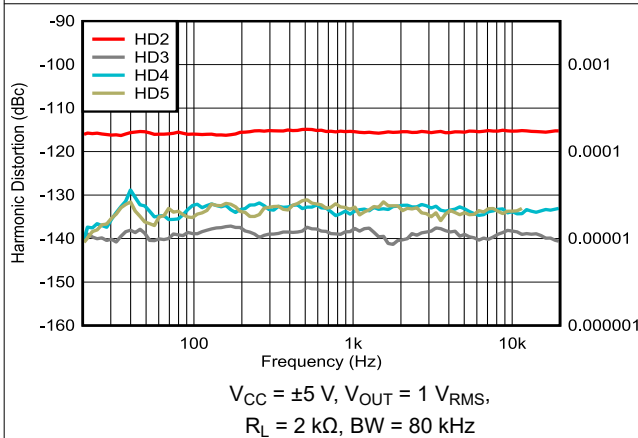

**Figure 5-35. Distortion Harmonics vs Frequency**

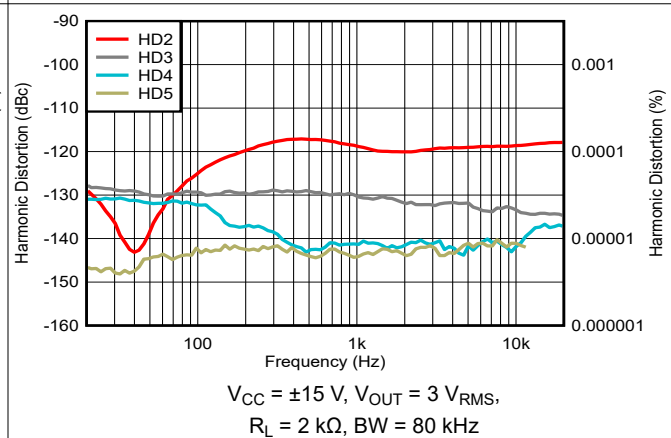

**Figure 5-36. Distortion Harmonics vs Frequency**

### 5.6 Typical Characteristics (continued)

at  $T_A = 25^\circ\text{C}$ ,  $V_{CC} = \pm 15\text{ V}$ , gain = +10 V/V,  $R_L = 150\ \Omega$ , and  $R_F = 220\ \Omega$  (unless otherwise noted)

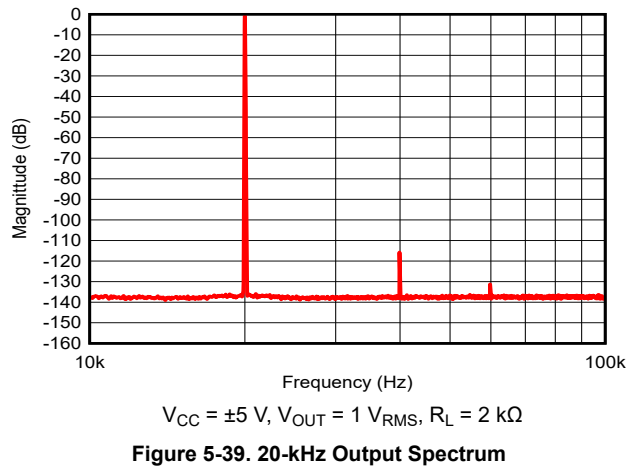
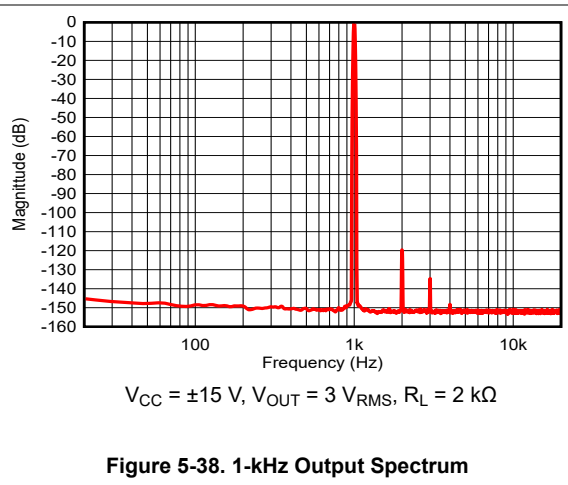
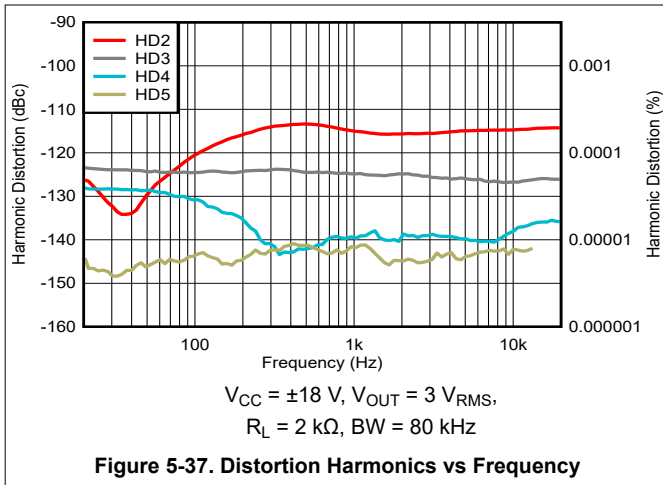

## 6 Detailed Description

### 6.1 Overview

The OPAx892 are high-speed operational amplifiers configured in a decompensated voltage-feedback architecture. The OPAx892 are stable with gain configurations of 10 V/V or greater. These amplifiers are built using a greater than 30-V, complementary, bipolar process with NPN and PNP transistors possessing an  $f_T$  of several GHz. This configuration results in exceptionally high-performance amplifiers with wide bandwidth, high slew rate, fast settling time, and low distortion.

### 6.2 Functional Block Diagram

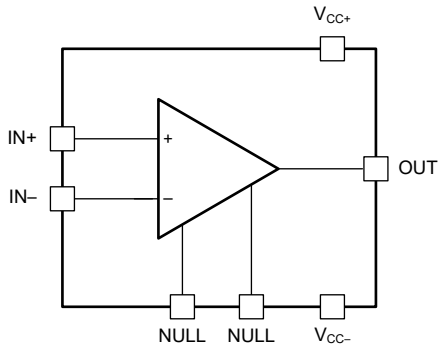

Figure 6-1. OPA892: Single Channel

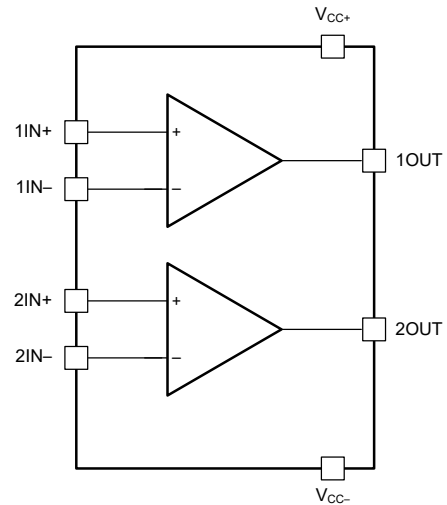

Figure 6-2. OPA2892: Dual Channel

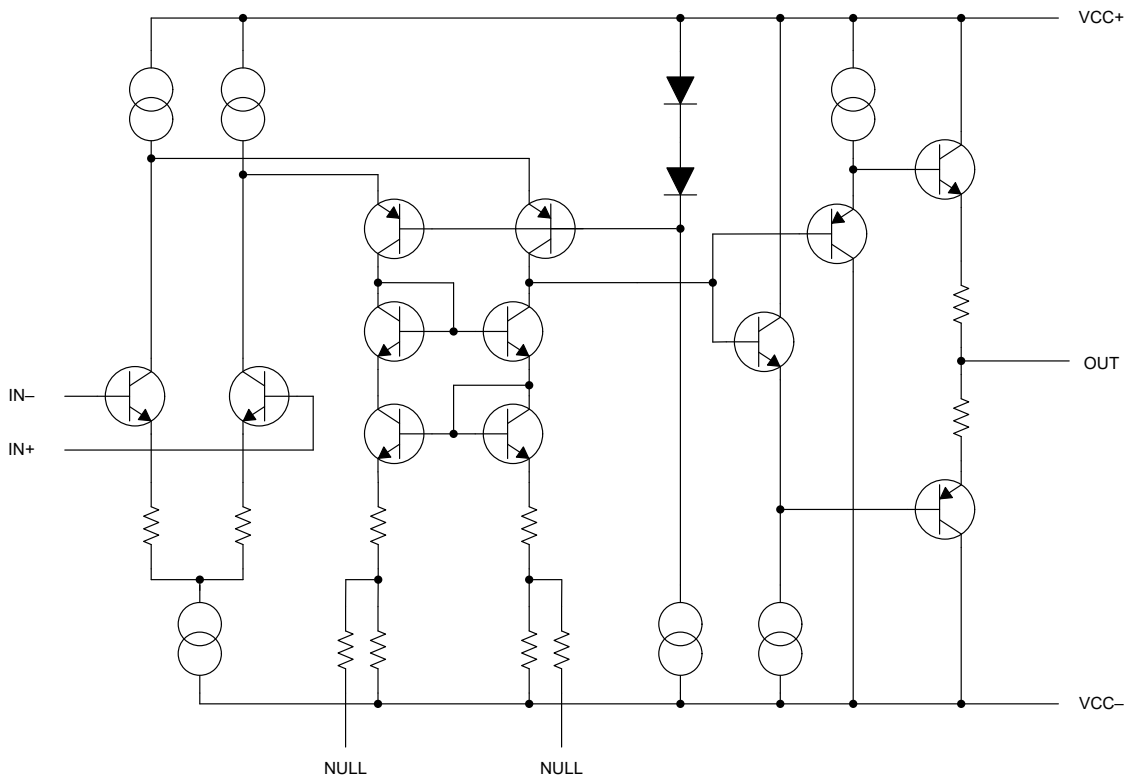
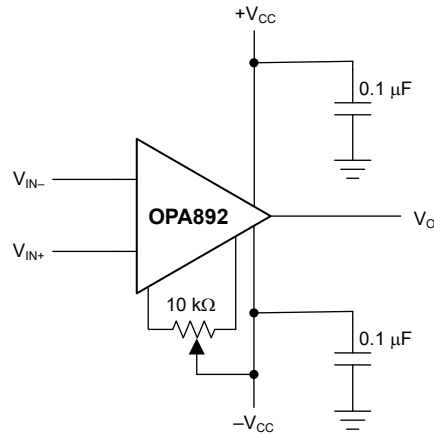

Figure 6-3. OPA892 Simplified Schematic

## 6.3 Feature Description

### 6.3.1 Offset Nulling

The OPAx892 have a very low input offset voltage for high-speed amplifiers. However, if additional correction is required, an offset nulling function is provided on the OPA892. To adjust the input offset voltage, place a potentiometer between pin 1 and pin 8 of the device, and tie the wiper to the negative supply. Figure 6-4 shows this feature.



**Figure 6-4. Offset Nulling Schematic**

## 6.4 Device Functional Modes

The OPAx892 family has a single functional mode and can be used with both single-supply or split power-supply configurations. The power-supply voltage must be greater than 9 V ( $\pm 4.5$  V) and less than 36 V ( $\pm 18$  V).

## 7 Application and Implementation

### Note

Information in the following applications sections is not part of the TI component specification, and TI does not warrant its accuracy or completeness. TI's customers are responsible for determining suitability of components for their purposes, as well as validating and testing their design implementation to confirm system functionality.

### 7.1 Application Information

#### 7.1.1 Driving a Capacitive Load

The OPAx892 are internally compensated to maximize bandwidth and slew-rate performance. To maintain stability, take additional precautions when driving capacitive loads with a high-performance amplifier. As a result of the internal compensation, significant capacitive loading directly on the output node decreases the device phase margin, and potentially lead to high-frequency ringing or oscillations. Therefore, for capacitive loads greater than 10 pF, place an isolation resistor in series with the output of the amplifier. [Figure 7-1](#) shows this configuration. For most applications, a minimum resistance of 20  $\Omega$  is recommended. In 75- $\Omega$  transmission systems, setting the series resistor value to 75  $\Omega$  is a beneficial choice because this value isolates any capacitance loading and provides source impedance matching.

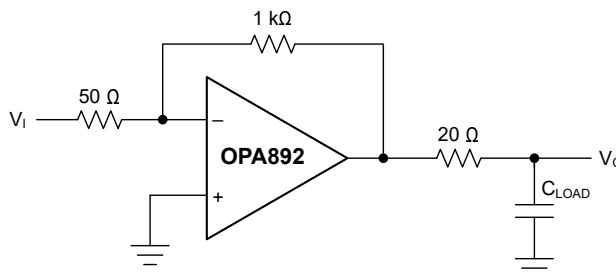

**Figure 7-1. Driving a Capacitive Load**

#### 7.1.2 General Configuration

When receiving low-level signals, limiting the bandwidth of the incoming signals into the system is often required. [Figure 7-2](#) shows how the simplest way to accomplish this limiting is to place an RC filter at the noninverting pin of the amplifier.

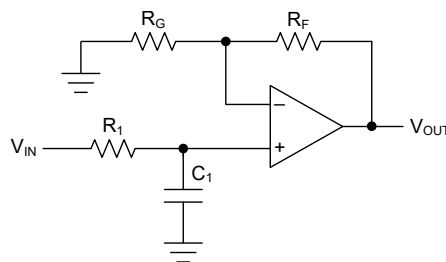

**Figure 7-2. Single-Pole Low-Pass Filter**

$$\frac{V_{OUT}}{V_{IN}} = \left(1 + \frac{R_F}{R_G}\right) \times \left(\frac{1}{1 + sR_1C_1}\right) \quad (1)$$

## 7.2 Typical Application

One important characteristic of the OPAx892 amplifier is the decompensated architecture. By pushing out the dominate pole to a higher frequency using this common technique, the amplifier is no longer stable in lower gain configurations. The minimum stable gain for the OPAx892 is specified to be 10 V/V. When a lower gain is needed in a preamp or buffer application, a related product to be considered is the OPA891. Because the OPA891 is not decompensated, the gain-bandwidth product is approximately an order of magnitude lower than the OPAx892. Both of these amplifiers have similar noise performance, but the best bandwidth and distortion performance comes from using the correct amplifier depending on the gain needs of the application.

When applications require gain of 10 V/V or larger, choose the OPAx892 to obtain a low value of harmonic distortion and THD+N. Figure 7-3 shows a where in the analog signal chain this type of amplification can be required. Often found in applications such as ultrasound, audio, and sonar, a preamp is used near the input sensor to boost the signal to a more practical level with an emphasis on keeping noise and distortion as small as possible. Later in the signal chain, significantly more gain can be required to provide for other required functions such analog filtering, mixing, splitting, or just the need to match the signal level to a following device. An amplifier such as the OPAx892 maintains the fidelity of the signal by providing the needed gain with significantly impacting distortion over a wide bandwidth and output swing. Figure 7-4 shows the amplifier design example. The amplification stage provides an additional 10 V/V of gain to the analog signal chain.

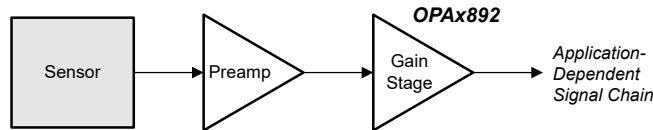

Figure 7-3. Gain Stage in an Analog-Front-End Block Diagram

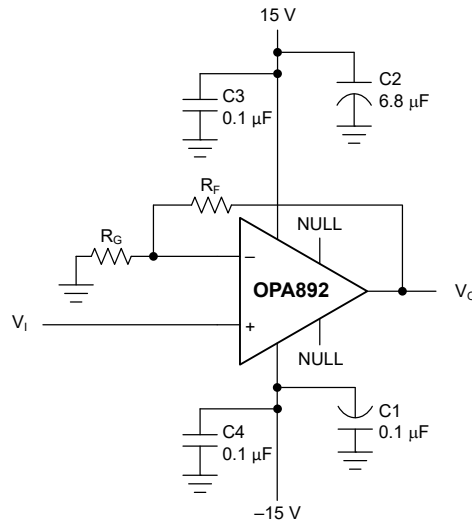

Figure 7-4. Noninverting Gain Configuration

### 7.2.1 Design Requirements

The objective is to design a 10 V/V amplifier to be for a mid-stage amplifier that minimizes the THD of the signal over the output range shown in Table 7-1.

Table 7-1. Design Parameters

PARAMETER	VALUE
Supply voltage	±15 V
Voltage gain	+10 V/V
Small-signal peaking	< 2 dB
Load resistance	1 kΩ

### 7.2.2 Detailed Design Procedure

As detailed by Figure 7-4, the example design is a common non-inverting op-amp configuration. In this design example, the split  $\pm 15$  V supplies are bypassed by a pair of capacitors as discussed in Section 7.4.1. Although not explicitly shown, an optional resistor equal to  $R_F \parallel R_G$  can be added from the noninverting input to ground to keep the inputs balanced to help mitigate input bias current impact.

Set the gain to 10 V/V by the proper selection of the two resistors using Equation 2. In this example, set the ratio of the resistance to 9 to obtain the design goal of a gain of 10. There exists a second degree of freedom that allows the absolute value to be somewhat arbitrary while maintaining the specified ratio of resistor values. Increasing feedback resistance leads to an increase in the amount of overshoot in the small-signal frequency response (see Figure 5-1). In the time domain, the impact shows up as an increase in ringing and settling time for step-function input signals. If the resistances are very small, power dissipation effects increase.

$$\text{gain} = \frac{V_O}{V_I} = 1 + \frac{R_F}{R_G} \quad (2)$$

The best practice is to choose the resistors to be in of moderate values to avoid the detrimental effects at both extremes. Choosing  $R_F = 220 \Omega$  is a good compromise in between these two extremes. Using Equation 2, the corresponding gain resistor is found to be  $24 \Omega$ . The amount of small-signal peaking is a modest 1.5 dB (see Figure 5-1), which meets the design goal.

A unique feature of this amplifier family is the output stage has been designed to drive a substantial amount of output current. This choice allows for the OPAx892 to maintain significant bandwidth even with very large input signals. Figure 7-5 shows the modest reduction of bandwidth, even for output signals as large as  $20 V_{PP}$ . The time domain impact of this feature is a more precise amplification (that is, lower distortion) even for large dynamic range input signals.

Using the amplifier designed in this section, Figure 7-6 shows the measured components of THD down to the 5th harmonic. The figure shows that the 2nd harmonic dictates the THD performance, with the 4th harmonic being the next highest component. Other amplifiers can produce low distortion at lower input levels but distortion rapidly rises as the output amplitude rises. Figure 5-17 shows the harmonic distortion stays approximately constant, even at large values of output amplitude, making the OPAx892 a solid choice for large amplitude applications where distortion and noise are critical considerations.

### 7.2.3 Application Curves

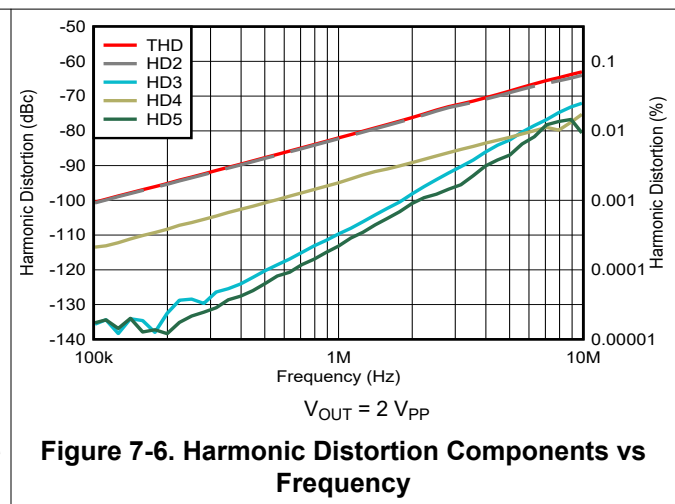
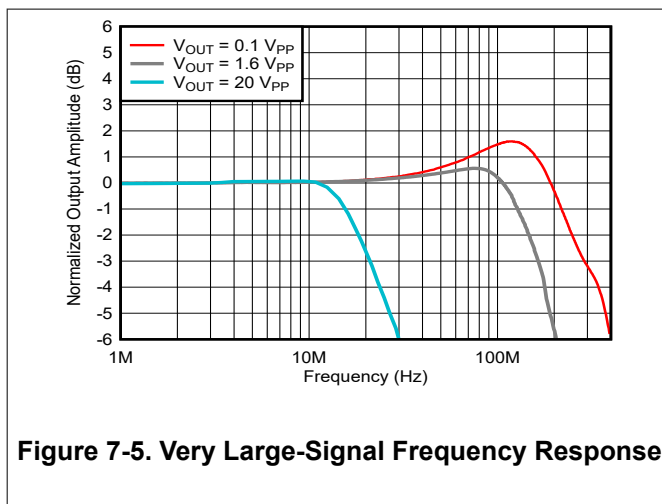

## 7.3 Power Supply Recommendations

The OPAx892 devices are designed to operate on power supplies ranging from  $\pm 4.5$  V to  $\pm 16$  V (single-ended supplies of 9 V to 32 V). Use a power-supply accuracy of 5% or better. When operated on a board with high-speed digital signals, provide isolation between digital signal noise and the analog input pins. The OPAx892 are connected to the positive power supply ( $V_{CC+}$ ) through pin 7 and pin 8, respectively. Both devices use pin 4 for the negative power supply ( $V_{CC-}$ ). Decouple each supply pin to GND as close to the device as possible.

## 7.4 Layout

### 7.4.1 Layout Guidelines

To achieve the levels of high-frequency performance of the OPAx892, follow proper printed-circuit board (PCB), high-frequency design techniques. The following is a general set of guidelines. In addition, a OPAx892 evaluation board is available to use as a guide for layout or for evaluating the device performance.

- **Ground planes**—ensure that the ground plane used on the board provides all components with a low-inductive ground connection. However, in the areas of the amplifier inputs and output, the ground plane can be removed to minimize stray capacitance.
- **Proper power-supply decoupling**—use a 6.8- $\mu$ F tantalum capacitor in parallel with a 0.1- $\mu$ F ceramic capacitor on each supply pin. Sharing the tantalum capacitor among several amplifiers is possible depending on the application, but always use a 0.1- $\mu$ F ceramic capacitor on the supply pin of every amplifier. In addition, place the 0.1- $\mu$ F capacitor as close as possible to the supply pin. As this distance increases, the inductance in the connecting trace makes the capacitor less effective. Strive for distances of less than 0.1 inch (2.54 mm) between the device power pins and the ceramic capacitors.
- **Short trace runs or compact part placements**—optimized high-frequency performance is achieved when stray series inductance has been minimized. To realize this, make the circuit layout as compact as possible, thereby minimizing the length of all trace runs. Pay particular attention to the inputs of the amplifier, keeping the trace lengths as short as possible. This layout helps to minimize stray capacitance at the input of the amplifier.

#### 7.4.1.1 General PowerPAD™ Integrated Circuit Package Design Considerations

The OPAx892 is available in a thermally-enhanced DGN package, which is a member of the PowerPAD™ integrated circuit package family. Figure 7-7 a and Figure 7-7 b show that this package is constructed using a downset leadframe upon which the die is mounted. Figure 7-7 c that this arrangement results in the leadframe being exposed as a thermal pad on the underside of the package. Because this thermal pad has direct thermal contact with the die, excellent thermal performance can be achieved by providing a good thermal path away from the thermal pad.

The PowerPAD integrated circuit package allows for both assembly and thermal management in one manufacturing operation. During the surface-mount solder operation (when the leads are being soldered), the thermal pad can also be soldered to a copper area underneath the package. Through the use of thermal paths within this copper area, heat can be conducted away from the package into either a ground plane or other heat dissipating device.

The PowerPAD integrated circuit package represents a breakthrough in combining the small area and ease of assembly of the surface mount with the previously awkward mechanical methods of heat sinking.

More complete details of the PowerPAD integrated circuit package installation process and thermal management techniques are found in [PowerPAD Thermally-Enhanced Package](#). This document is found on the TI website ([www.ti.com](http://www.ti.com)) by searching on the keyword PowerPAD. The document can also be ordered through your local TI sales office; refer to SLMA002 when ordering.

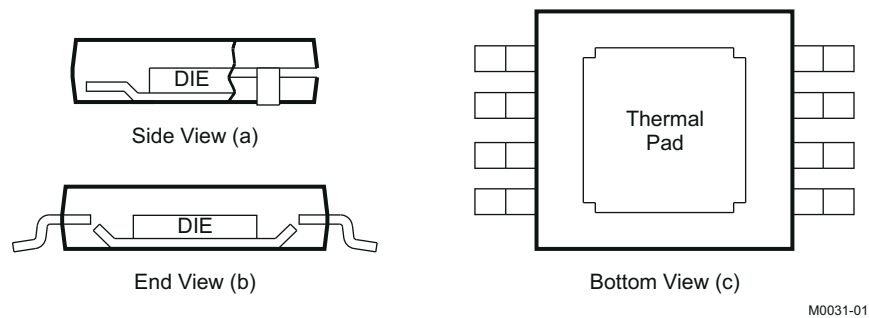

NOTE: The thermal pad (PowerPAD integrated circuit package) is electrically isolated from all other pins and can be connected to any potential from  $V_{CC-}$  to  $V_{CC+}$ . Typically, the thermal pad is connected to the ground plane because this plane tends to physically be the largest and is able to dissipate the most amount of heat.

**Figure 7-7. Views of Thermally-Enhanced DGN Package**

### 7.4.2 Layout Example

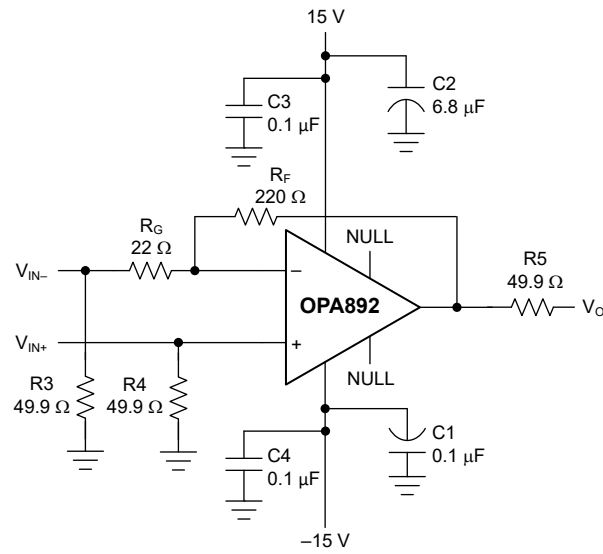

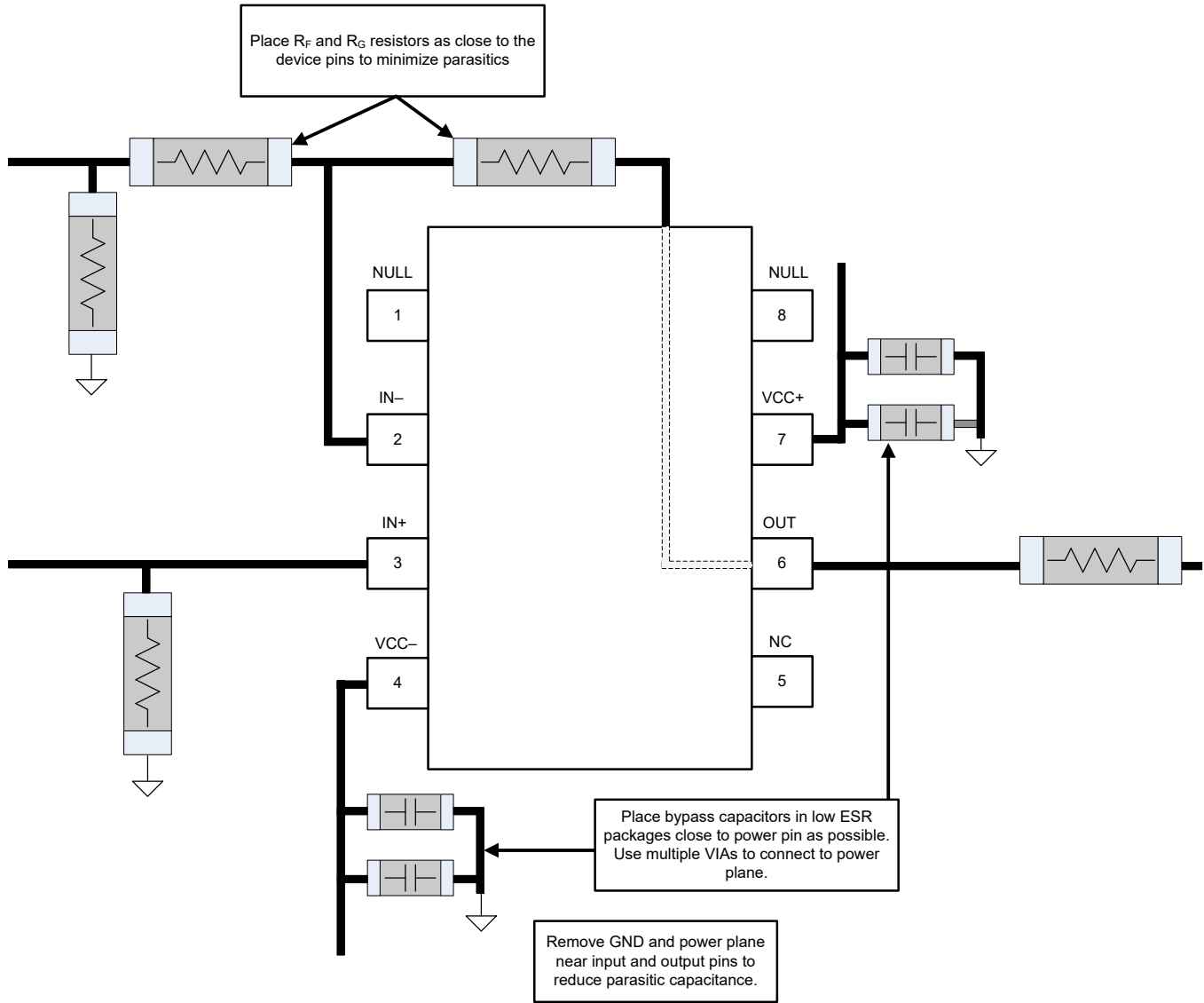

**Figure 7-8. Layout Recommendations**

## 8 Device and Documentation Support

TI offers an extensive line of development tools. Tools and software to evaluate the performance of the device, generate code, and develop solutions are listed below.

### 8.1 Documentation Support

#### 8.1.1 Related Documentation

For related documentation, see the following:

- Texas Instruments, [Noise Analysis in Operational Amplifier Circuits application report](#)
- Texas Instruments, [PowerPAD Thermally Enhanced Package application report](#)
- Texas Instruments, [Single op-amp evaluation module for SO-8 package users guide](#)
- Texas Instruments, [Dual op-amp evaluation module for SO-8 package users guide](#)
- Texas Instruments, [Dual op amp evaluation module for MSOP-8 package users guide](#)

### 8.2 Receiving Notification of Documentation Updates

To receive notification of documentation updates, navigate to the device product folder on [ti.com](http://ti.com). Click on *Notifications* to register and receive a weekly digest of any product information that has changed. For change details, review the revision history included in any revised document.

### 8.3 Support Resources

[TI E2E™ support forums](#) are an engineer's go-to source for fast, verified answers and design help — straight from the experts. Search existing answers or ask your own question to get the quick design help you need.

Linked content is provided "AS IS" by the respective contributors. They do not constitute TI specifications and do not necessarily reflect TI's views; see TI's [Terms of Use](#).

### 8.4 Trademarks

PowerPAD™ and TI E2E™ are trademarks of Texas Instruments. All trademarks are the property of their respective owners.

### 8.5 Electrostatic Discharge Caution



This integrated circuit can be damaged by ESD. Texas Instruments recommends that all integrated circuits be handled with appropriate precautions. Failure to observe proper handling and installation procedures can cause damage.

ESD damage can range from subtle performance degradation to complete device failure. Precision integrated circuits may be more susceptible to damage because very small parametric changes could cause the device not to meet its published specifications.

### 8.6 Glossary

[TI Glossary](#) This glossary lists and explains terms, acronyms, and definitions.

## 9 Revision History

NOTE: Page numbers for previous revisions may differ from page numbers in the current version.

<b>Changes from Revision * (November 2023) to Revision A (July 2024)</b>	<b>Page</b>
• Changed OPA2892 status from preview to production data (active).....	1
• Added thermal pad information to Table 4-2, <i>Pin Functions: OPA2892</i> .....	3
• Added missing unit for Supply current in <i>Electrical Characteristics</i> .....	5
• Added Figure 5-20, <i>OPA2892 Crosstalk vs Frequency</i> .....	7

## 10 Mechanical, Packaging, and Orderable Information

The following pages include mechanical, packaging, and orderable information. This information is the most current data available for the designated devices. This data is subject to change without notice and revision of this document. For browser-based versions of this data sheet, refer to the left-hand navigation.

**PACKAGING INFORMATION**

Orderable part number	Status (1)	Material type (2)	Package   Pins	Package qty   Carrier	RoHS (3)	Lead finish/ Ball material (4)	MSL rating/ Peak reflow (5)	Op temp (°C)	Part marking (6)
<a href="#">OPA2892DGNR</a>	Active	Production	HVSSOP (DGN)   8	3000   LARGE T&R	Yes	NIPDAU	Level-2-260C-1 YEAR	-40 to 85	2892
OPA2892DGNR.B	Active	Production	HVSSOP (DGN)   8	3000   LARGE T&R	Yes	NIPDAU	Level-2-260C-1 YEAR	-40 to 85	2892
<a href="#">OPA892DR</a>	Active	Production	SOIC (D)   8	3000   LARGE T&R	Yes	NIPDAU	Level-1-260C-UNLIM	-40 to 85	O892
OPA892DR.B	Active	Production	SOIC (D)   8	3000   LARGE T&R	Yes	NIPDAU	Level-1-260C-UNLIM	-40 to 85	O892

<sup>(1)</sup> **Status:** For more details on status, see our [product life cycle](#).

<sup>(2)</sup> **Material type:** When designated, preproduction parts are prototypes/experimental devices, and are not yet approved or released for full production. Testing and final process, including without limitation quality assurance, reliability performance testing, and/or process qualification, may not yet be complete, and this item is subject to further changes or possible discontinuation. If available for ordering, purchases will be subject to an additional waiver at checkout, and are intended for early internal evaluation purposes only. These items are sold without warranties of any kind.

<sup>(3)</sup> **RoHS values:** Yes, No, RoHS Exempt. See the [TI RoHS Statement](#) for additional information and value definition.

<sup>(4)</sup> **Lead finish/Ball material:** Parts may have multiple material finish options. Finish options are separated by a vertical ruled line. Lead finish/Ball material values may wrap to two lines if the finish value exceeds the maximum column width.

<sup>(5)</sup> **MSL rating/Peak reflow:** The moisture sensitivity level ratings and peak solder (reflow) temperatures. In the event that a part has multiple moisture sensitivity ratings, only the lowest level per JEDEC standards is shown. Refer to the shipping label for the actual reflow temperature that will be used to mount the part to the printed circuit board.

<sup>(6)</sup> **Part marking:** There may be an additional marking, which relates to the logo, the lot trace code information, or the environmental category of the part.

Multiple part markings will be inside parentheses. Only one part marking contained in parentheses and separated by a "~" will appear on a part. If a line is indented then it is a continuation of the previous line and the two combined represent the entire part marking for that device.

**Important Information and Disclaimer:** The information provided on this page represents TI's knowledge and belief as of the date that it is provided. TI bases its knowledge and belief on information provided by third parties, and makes no representation or warranty as to the accuracy of such information. Efforts are underway to better integrate information from third parties. TI has taken and continues to take reasonable steps to provide representative and accurate information but may not have conducted destructive testing or chemical analysis on incoming materials and chemicals. TI and TI suppliers consider certain information to be proprietary, and thus CAS numbers and other limited information may not be available for release.

In no event shall TI's liability arising out of such information exceed the total purchase price of the TI part(s) at issue in this document sold by TI to Customer on an annual basis.

**TAPE AND REEL INFORMATION**

**QUADRANT ASSIGNMENTS FOR PIN 1 ORIENTATION IN TAPE**

\*All dimensions are nominal

Device	Package Type	Package Drawing	Pins	SPQ	Reel Diameter (mm)	Reel Width W1 (mm)	A0 (mm)	B0 (mm)	K0 (mm)	P1 (mm)	W (mm)	Pin1 Quadrant
OPA2892DGNR	HVSSOP	DGN	8	3000	330.0	12.4	5.3	3.4	1.4	8.0	12.0	Q1
OPA892DR	SOIC	D	8	3000	330.0	12.4	6.4	5.2	2.1	8.0	12.0	Q1

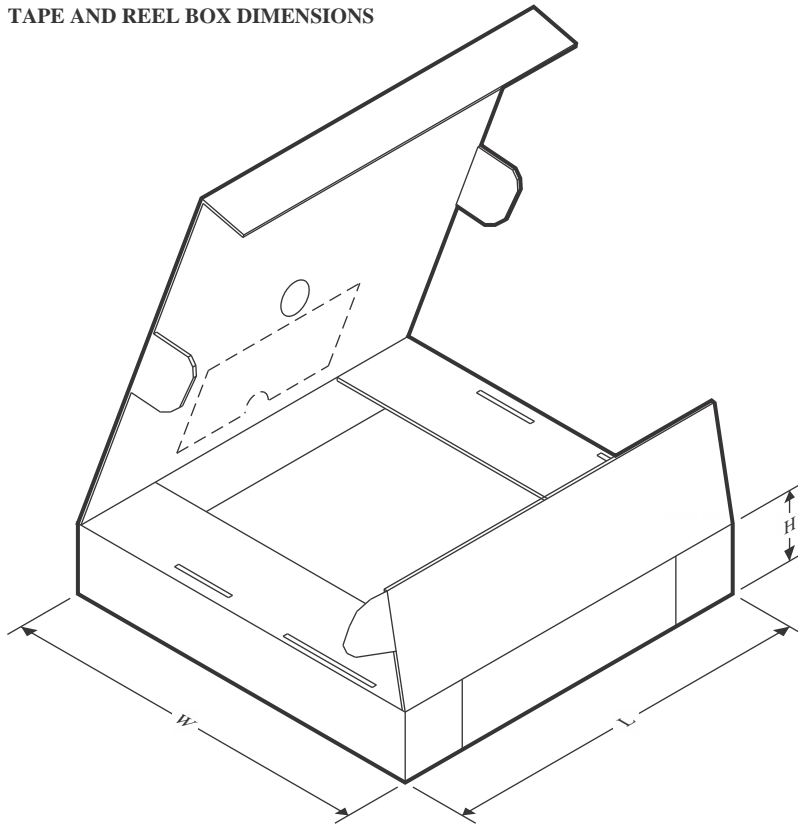
**TAPE AND REEL BOX DIMENSIONS**

\*All dimensions are nominal

Device	Package Type	Package Drawing	Pins	SPQ	Length (mm)	Width (mm)	Height (mm)
OPA2892DGNR	HVSSOP	DGN	8	3000	353.0	353.0	32.0
OPA892DR	SOIC	D	8	3000	353.0	353.0	32.0

## GENERIC PACKAGE VIEW

**DGN 8**

**PowerPAD™ HVSSOP - 1.1 mm max height**

3 x 3, 0.65 mm pitch

SMALL OUTLINE PACKAGE

This image is a representation of the package family, actual package may vary.  
Refer to the product data sheet for package details.

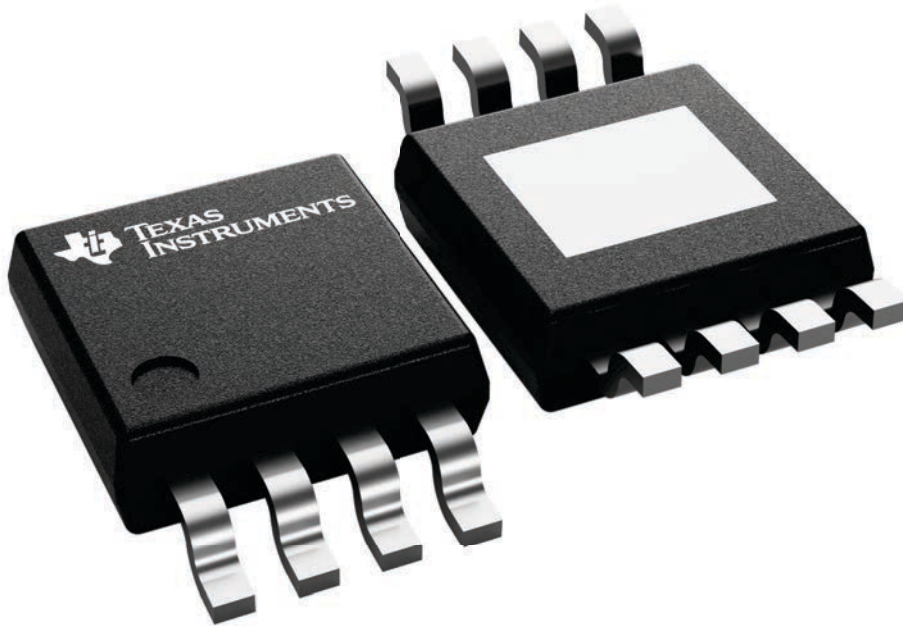

4225482/B

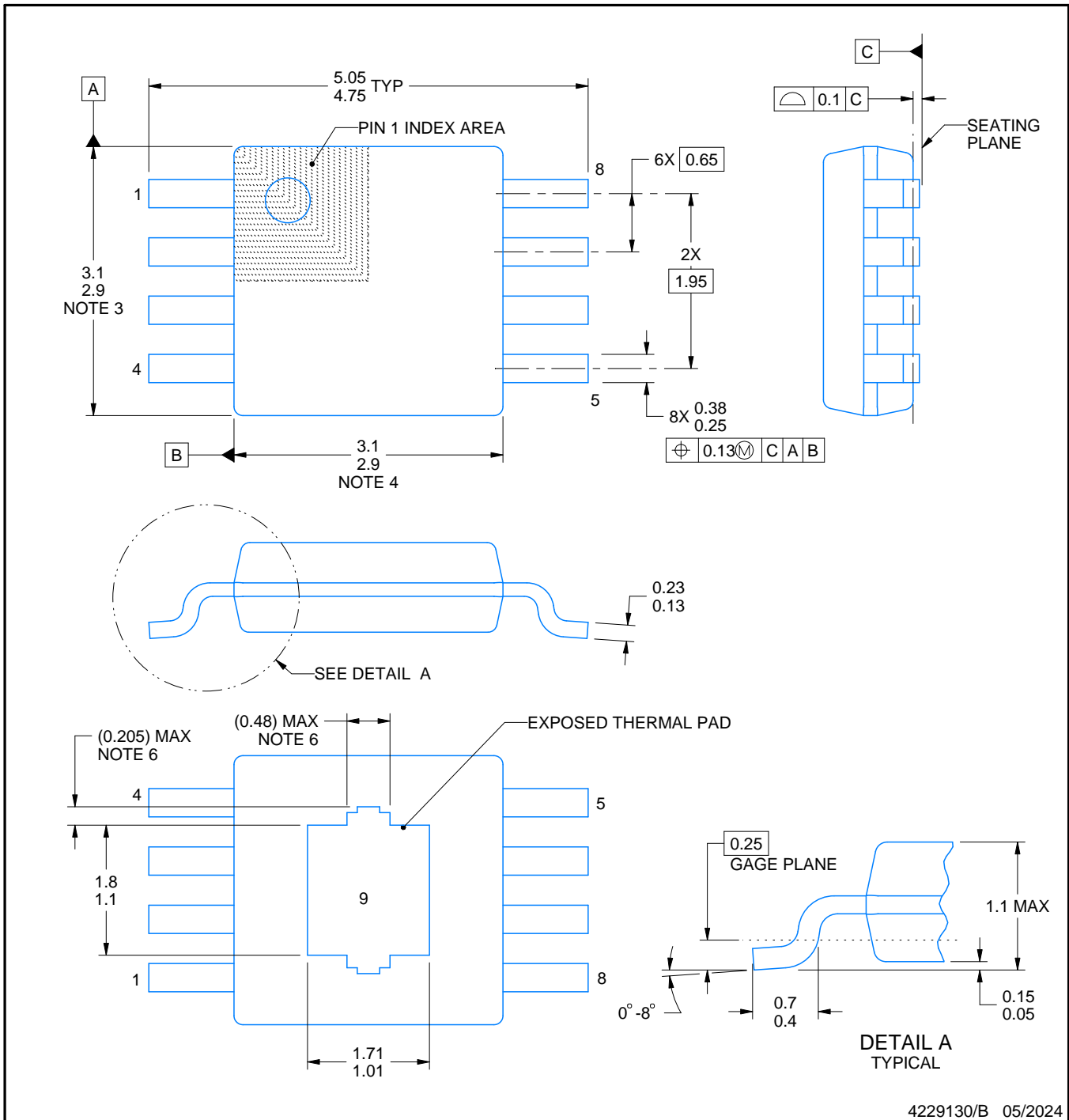
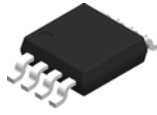

4229130/B 05/2024

NOTES:

PowerPAD is a trademark of Texas Instruments.

1. All linear dimensions are in millimeters. Any dimensions in parenthesis are for reference only. Dimensioning and tolerancing per ASME Y14.5M.
2. This drawing is subject to change without notice.
3. This dimension does not include mold flash, protrusions, or gate burrs. Mold flash, protrusions, or gate burrs shall not exceed 0.15 mm per side.
4. This dimension does not include interlead flash. Interlead flash shall not exceed 0.25 mm per side.
5. Reference JEDEC registration MO-187.
6. Features may differ or may not be present.



# EXAMPLE STENCIL DESIGN

DGN0008H

PowerPAD™ VSSOP - 1.1 mm max height

SMALL OUTLINE PACKAGE

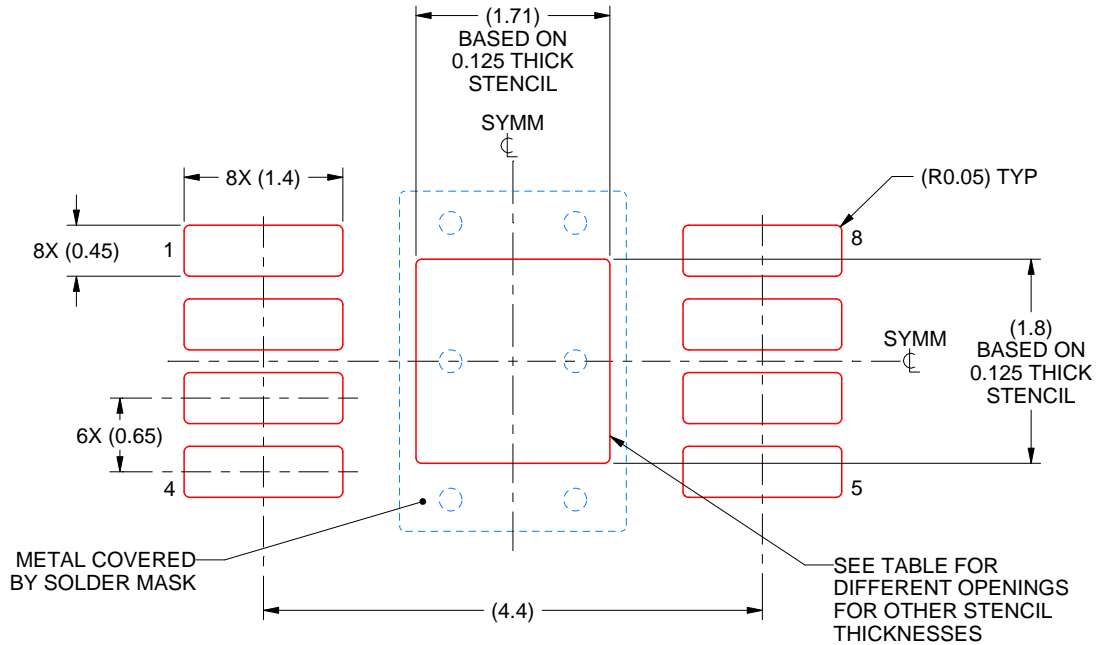

**SOLDER PASTE EXAMPLE**  
EXPOSED PAD 9:  
100% PRINTED SOLDER COVERAGE BY AREA  
SCALE: 15X

STENCIL THICKNESS	SOLDER STENCIL OPENING
0.1	1.91 X 2.01
0.125	1.71 X 1.80 (SHOWN)
0.15	1.56 X 1.64
0.175	1.45 X 1.52

4229130/B 05/2024

NOTES: (continued)

11. Laser cutting apertures with trapezoidal walls and rounded corners may offer better paste release. IPC-7525 may have alternate design recommendations.
12. Board assembly site may have different recommendations for stencil design.



D0008A

# PACKAGE OUTLINE

SOIC - 1.75 mm max height

SMALL OUTLINE INTEGRATED CIRCUIT



4214825/C 02/2019

### NOTES:

- Linear dimensions are in inches [millimeters]. Dimensions in parenthesis are for reference only. Controlling dimensions are in inches. Dimensioning and tolerancing per ASME Y14.5M.
- This drawing is subject to change without notice.
- This dimension does not include mold flash, protrusions, or gate burrs. Mold flash, protrusions, or gate burrs shall not exceed .006 [0.15] per side.
- This dimension does not include interlead flash.
- Reference JEDEC registration MS-012, variation AA.

# EXAMPLE BOARD LAYOUT

D0008A

SOIC - 1.75 mm max height

SMALL OUTLINE INTEGRATED CIRCUIT



LAND PATTERN EXAMPLE  
 EXPOSED METAL SHOWN  
 SCALE:8X



SOLDER MASK DETAILS

4214825/C 02/2019

NOTES: (continued)

6. Publication IPC-7351 may have alternate designs.

7. Solder mask tolerances between and around signal pads can vary based on board fabrication site.

# EXAMPLE STENCIL DESIGN

D0008A

SOIC - 1.75 mm max height

SMALL OUTLINE INTEGRATED CIRCUIT



SOLDER PASTE EXAMPLE  
BASED ON .005 INCH [0.125 MM] THICK STENCIL  
SCALE:8X

4214825/C 02/2019

NOTES: (continued)

8. Laser cutting apertures with trapezoidal walls and rounded corners may offer better paste release. IPC-7525 may have alternate design recommendations.
9. Board assembly site may have different recommendations for stencil design.

## IMPORTANT NOTICE AND DISCLAIMER

TI PROVIDES TECHNICAL AND RELIABILITY DATA (INCLUDING DATASHEETS), DESIGN RESOURCES (INCLUDING REFERENCE DESIGNS), APPLICATION OR OTHER DESIGN ADVICE, WEB TOOLS, SAFETY INFORMATION, AND OTHER RESOURCES "AS IS" AND WITH ALL FAULTS, AND DISCLAIMS ALL WARRANTIES, EXPRESS AND IMPLIED, INCLUDING WITHOUT LIMITATION ANY IMPLIED WARRANTIES OF MERCHANTABILITY, FITNESS FOR A PARTICULAR PURPOSE OR NON-INFRINGEMENT OF THIRD PARTY INTELLECTUAL PROPERTY RIGHTS.

These resources are intended for skilled developers designing with TI products. You are solely responsible for (1) selecting the appropriate TI products for your application, (2) designing, validating and testing your application, and (3) ensuring your application meets applicable standards, and any other safety, security, regulatory or other requirements.

These resources are subject to change without notice. TI grants you permission to use these resources only for development of an application that uses the TI products described in the resource. Other reproduction and display of these resources is prohibited. No license is granted to any other TI intellectual property right or to any third party intellectual property right. TI disclaims responsibility for, and you fully indemnify TI and its representatives against any claims, damages, costs, losses, and liabilities arising out of your use of these resources.

TI's products are provided subject to [TI's Terms of Sale](#), [TI's General Quality Guidelines](#), or other applicable terms available either on [ti.com](#) or provided in conjunction with such TI products. TI's provision of these resources does not expand or otherwise alter TI's applicable warranties or warranty disclaimers for TI products. Unless TI explicitly designates a product as custom or customer-specified, TI products are standard, catalog, general purpose devices.

TI objects to and rejects any additional or different terms you may propose.

Copyright © 2025, Texas Instruments Incorporated

Last updated 10/2025

## Looking for pricing, stock, or lifecycle information?

Click below to explore more details on WIN SOURCE:

 [View OPA892DR](#) on WIN SOURCE

 [Texas Instruments](#) Information

## Optimize Your Supply Chain with WIN SOURCE Solutions

-  Global Sourcing Solution
-  Obsolete Management
-  Cost Control Management
-  Shortage Management
-  Alternative Solution
-  Excess Inventory Management