



**THE DATASHEET OF  
MB85RS64TPN-G-AMEWE1**



# NCA9306

2-bit bidirectional multi-voltage level translator; open-drain; push-pull

Rev. 3.1 — 5 August 2024

Product data sheet

## 1. General description

The NCA9306 is a 2 channel bidirectional I<sup>2</sup>C and SMBus multi-voltage level translator with an enable (EN) pin input. It allows voltage translation between 0.95 V and 5 V without the use of a direction pin. It supports up to 100 MHz up translation and >100 MHz down translation at  $\leq 30$  pF capacitive load. There is no need for a direction pin which minimizes the system effort. The NCA9306 supports 5 V tolerant I/O pins to support mixed mode signal operation. The ability to set up different voltage translation levels on each channel makes the device very flexible and suitable for a lot of different applications.

The low ON-state resistance  $R_{ON}$  of the switch allows connections to be made with minimal propagation delay. When EN is HIGH, the translator switch is on, and the SCLA and SDAA I/O are connected to the SCLB and SDAB I/O respectively, allowing bidirectional data flow between ports. When EN is LOW, the translator switch is off, and a high-impedance state exists between ports. As with the standard I<sup>2</sup>C bus-system, pull-up resistors are required to provide the logic HIGH levels on the translators bus. The NCA9306 has a standard open-drain configuration of the I<sup>2</sup>C-bus. The size of these pull-up resistors depend on the system. Each side of the translator must have a pull-up resistors. NCA9306 is designed to work with Standard-mode, Fast-mode and Fast-mode plus I<sup>2</sup>C bus devices in addition to the SMBus devices.

When the SDAA or SDAB pin is LOW, the clamp is in the ON-state and a low resistance connections exists between the SDAA and SDAB ports. Assuming the higher voltage is on the SDAB port when the SDAB port is HIGH, the voltage on the SDAA port is limited to the voltage set by refA. When the SDAA port is HIGH, the SDAB port is pulled to the refB supply voltage by the pull-up resistors. The SCLA or SCLB pins also follows the same behavior as described for SDAA or SDAB pins.

## 2. Features and benefits

- 2-channel bidirectional voltage translator for SDA and SCL lines in mixed mode I<sup>2</sup>C bus applications
- Open-drain I<sup>2</sup>C-bus I/O ports (SCLA, SDAA, SCLB and SDAB)
- Provides bidirectional voltage translation with no direction pin
- High-impedance SCLA, SDAA, SCLB and SDAB for EN = LOW
- Up translation
  - < 100 MHz;  $C_L = 30$  pF
  - < 40 MHz;  $C_L = 50$  pF
- Down translation
  - > 100 MHz;  $C_L = 30$  pF
  - < 40 MHz;  $C_L = 50$  pF
- Hot insertion
- Bidirectional voltage level translation between:
  - 0.95 V and 1.8 V, 2.5 V, 3.3 V and 5.0 V
  - 1.2 V and 1.8 V, 2.5 V, 3.3 V and 5.0 V
  - 1.8 V and 2.5 V, 3.3 V and 5.0 V
  - 2.5 V and 3.3 V and 5.0 V
  - 3.3 V and 5.0 V
- Low standby current
- 5 V tolerant I<sup>2</sup>C-bus I/O pins to support mixed mode signal operation

**2-bit bidirectional multi-voltage level translator; open-drain; push-pull**

- Low  $R_{ON}$  provides less signal distortion
- Latch-up performance exceeds 100 mA per JESD78 class II level A
- ESD protection:
  - HBM ANSI/ESDA/JEDEC JS-001 class 2 exceeds 2000 V
  - CDM ANSI/ESDA/JEDEC JS-002 class C3 exceeds 1000 V
- Specified from  $-40\text{ }^{\circ}\text{C}$  to  $+125\text{ }^{\circ}\text{C}$

### 3. Applications

- GPIO, MDIO, PMBus, SMBus, SDIO, UART, I<sup>2</sup>C, and other interfaces in Telecom infrastructure
- Industrial
- Personal computing
- Router and Industrial Automation

### 4. Ordering information

**Table 1. Ordering information**

Type number	Package			Version
	Temperature range	Name	Description	
<a href="#">NCA9306DP</a>	$-40\text{ }^{\circ}\text{C}$ to $+125\text{ }^{\circ}\text{C}$	TSSOP8	plastic thin shrink small outline package; 8 leads; body width 3 mm; lead length 0.5 mm	<a href="#">SOT505-2</a>
<a href="#">NCA9306DC</a>	$-40\text{ }^{\circ}\text{C}$ to $+125\text{ }^{\circ}\text{C}$	VSSOP8	plastic very thin shrink small outline package; 8 leads; body width 2.3 mm	<a href="#">SOT765-1</a>
<a href="#">NCA9306GS</a>	$-40\text{ }^{\circ}\text{C}$ to $+125\text{ }^{\circ}\text{C}$	XSON8	extremely thin small outline package; no leads; 8 terminals; body $1.35 \times 1.0 \times 0.35\text{ mm}$	<a href="#">SOT1203</a>
<a href="#">NCA9306GX</a>	$-40\text{ }^{\circ}\text{C}$ to $+125\text{ }^{\circ}\text{C}$	X2SON8	plastic thermal enhanced extremely thin small outline package; no leads; 8 terminals; body $1.35 \times 0.8 \times 0.32\text{ mm}$	<a href="#">SOT1233-2</a>

### 5. Marking

**Table 2. Marking**

Type number	Marking code[1]
NCA9306DP	h9
NCA9306DC	h9
NCA9306GS	h9
NCA9306GX	h9

[1] The pin 1 indicator is located on the lower left corner of the device, below the marking code.

### 6. Functional diagram

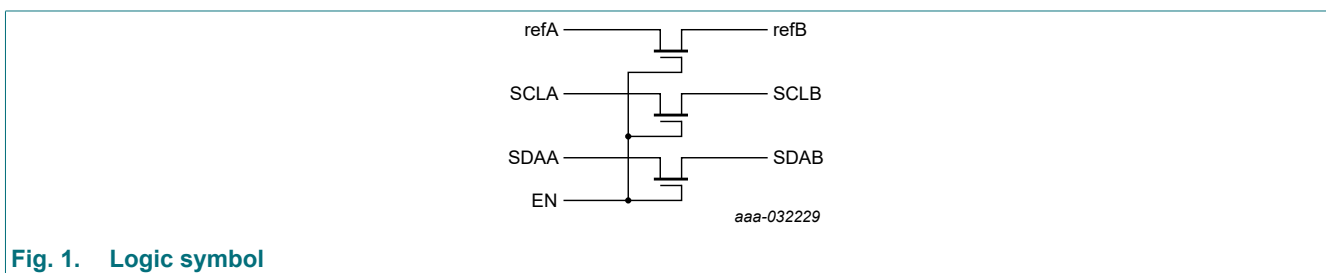

## 7. Pinning information

### 7.1. Pinning

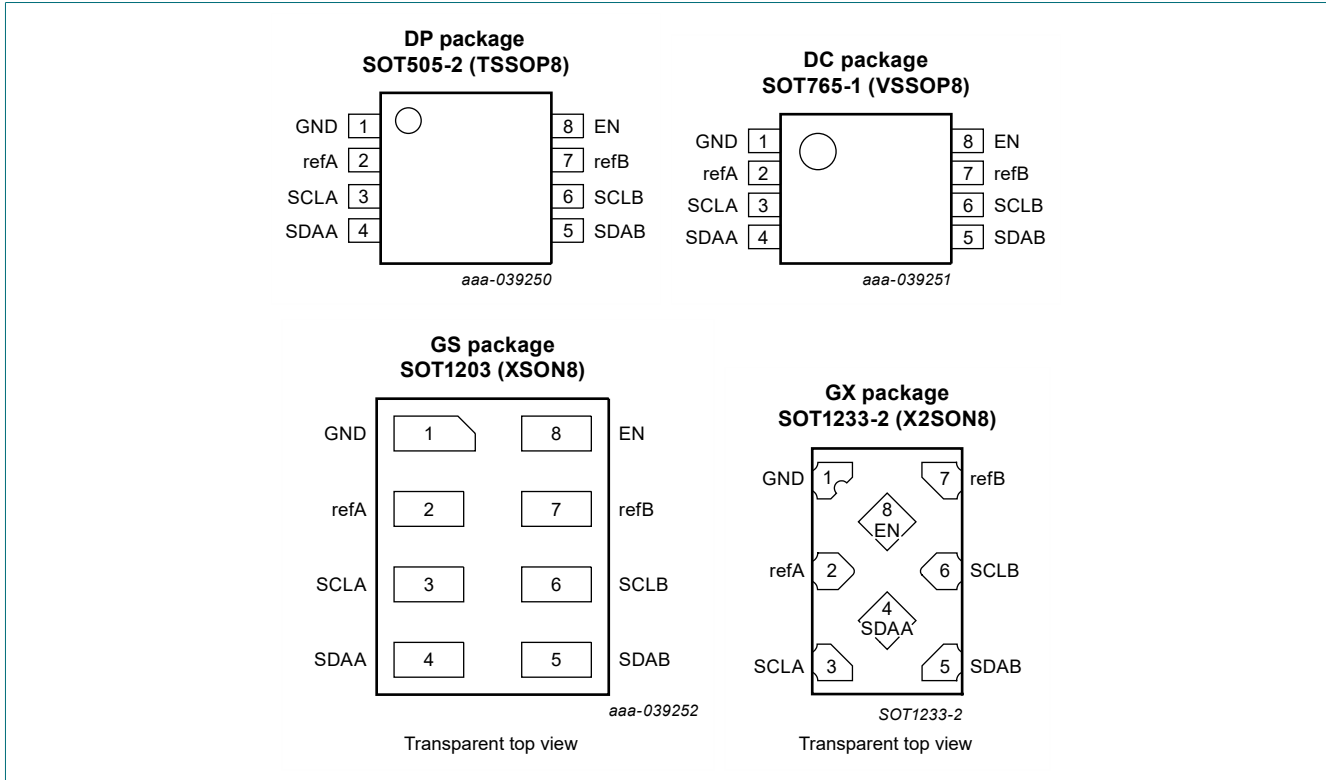

### 7.2. Pin description

Table 3. Pin description

Symbol	Pin	Description
GND	1	ground (0 V)
refA	2	low-voltage side reference supply voltage for SCLA and SDAA
SCLA, SCLB	3, 6	data input/output SCL
SDAA, SDAB	4, 5	data input/output SDA
refB	7	high-voltage side reference supply voltage for SCLB and SDAB
EN	8	enable input (active HIGH)

## 8. Functional description

Table 4. Function table

H = HIGH voltage level; L = LOW voltage level; Z = high-impedance OFF-state.

Input	input/output
EN	SCLn, SDAn channel
H	SCLA = SCLB; SDAA = SDAB
L	Z

## 9. Limiting values

**Table 5. Limiting values**

In accordance with the Absolute Maximum Rating System (IEC 60134). Voltages are referenced to GND (ground = 0 V).

Symbol	Parameter	Conditions	Min	Max	Unit
$V_I$	input voltage	pins refA, refB, SCLn, SDAn and EN [1]	-0.5	+7.0	V
$I_{I/O}$	input/output current	pins refA, refB, SCLn, SDAn; continuous channel current	-	+128	mA
$I_{IK}$	input clamping current	$V_I < 0$ V	-50	-	mA
$T_{stg}$	storage temperature		-65	+150	°C
$P_{tot}$	total power dissipation	$T_{amb} = -40$ °C to +125 °C			
		For SOT505-2, SOT765-1, SOT1203 [2]	-	250	mW
		For SOT1233-2 [3]	-	300	mW

[1] The minimum input voltage rating may be exceeded if the input current rating is observed.

[2] For SOT505-2 (TSSOP8) package:  $P_{tot}$  derates linearly with 4.6 mW/K above 96 °C.

For SOT765-1 (VSSOP8) package:  $P_{tot}$  derates linearly with 4.9 mW/K above 99 °C.

For SOT1203 (XSON8) package:  $P_{tot}$  derates linearly with 3.6 mW/K above 81 °C.

[3] For SOT1233-2 (X2SON8) package:  $P_{tot}$  derates linearly with 7.7 mW/K above 118 °C.

## 10. Recommended operating conditions

**Table 6. Recommended operating conditions**

Symbol	Parameter	Conditions	Min	Max	Unit
$V_I$	input voltage	pins refA, refB, SCLn, SDAn and EN	0.0	5.0	V
$I_{I/O}$	input/output current	pins refA, refB, SCLn, SDAn; continuous channel current	-	+64	mA
$T_{amb}$	ambient temperature		-40	+125	°C

## 11. Static characteristics

**Table 7. Static characteristics**

At recommended operating conditions voltages are referenced to GND (ground = 0 V).

Symbol	Parameter	Conditions	$T_{amb} = -40$ °C to +125 °C			Unit
			Min	Typ[1]	Max	
$V_{IK}$	input clamping voltage	$V_{EN} = 0$ V; $I_I = -18$ mA	-1.2	-	-	V
$I_I$	leakage current	pins SCLn, SDAn, refA, refB and EN; $V_I = \text{GND to } 5.0$ V	-	1	5	μA
$C_I$	input capacitance	pins refA, refB and EN; $V_I = 0$ V or 3 V	-	6	-	pF
$C_{io(off)}$	OFF-state input/output capacitance	pins SCLn, SDAn; $V_O = 0$ V or 3 V; $V_{EN} = 0.0$ V	-	3.0	6.0	pF
$C_{io(on)}$	ON-state input/output capacitance	pins SCLn, SDAn; $V_O = 0$ V or 3 V; $V_{EN} = 3.0$ V	-	6.0	12.5	pF

2-bit bidirectional multi-voltage level translator; open-drain; push-pull

Symbol	Parameter	Conditions	T <sub>amb</sub> = -40 °C to +125 °C			Unit
			Min	Typ[1]	Max	
R <sub>ON</sub>	ON resistance	see Fig. 2				
		V <sub>I</sub> = 0 V; V <sub>pu</sub> = 5.0 V; I <sub>O</sub> = 64 mA [2]				
		V <sub>refA</sub> = 3.3 V	-	3	7	Ω
		V <sub>refA</sub> = 1.8 V	-	4	10	Ω
		V <sub>I</sub> = 0 V; V <sub>refB</sub> = V <sub>EN</sub> = 5.0 V; I <sub>O</sub> = 32mA				
		V <sub>refA</sub> = 1.8 V	-	4	9	Ω
		V <sub>refA</sub> = 2.5 V	-	3	8	Ω
		V <sub>I</sub> = 1.8 V; V <sub>refB</sub> = V <sub>EN</sub> = 5.0 V; I <sub>O</sub> = 15 mA				
		V <sub>refA</sub> = 3.3 V	-	4	13	Ω
		V <sub>I</sub> = 1.0 V; V <sub>refB</sub> = V <sub>EN</sub> = 3.3 V; I <sub>O</sub> = 10 mA				
		V <sub>refA</sub> = 1.8 V	-	7	24	Ω
		V <sub>I</sub> = 0 V; V <sub>refB</sub> = V <sub>EN</sub> = 3.3 V; I <sub>O</sub> = 10 mA				
		V <sub>refA</sub> = 1.0 V	-	5	18	Ω
V <sub>I</sub> = 0 V; V <sub>refB</sub> = V <sub>EN</sub> = 1.8 V; I <sub>O</sub> = 10 mA						
V <sub>refA</sub> = 1.0 V	-	6	19	Ω		

- [1] All typical values are measured at T<sub>amb</sub> = 25 °C.
- [2] Measured by the voltage drop between the SCLn and SDAn pins at the indicated current through the switch. ON resistance is determined by the lowest voltage of the two (SCLn or SDAn) pins.

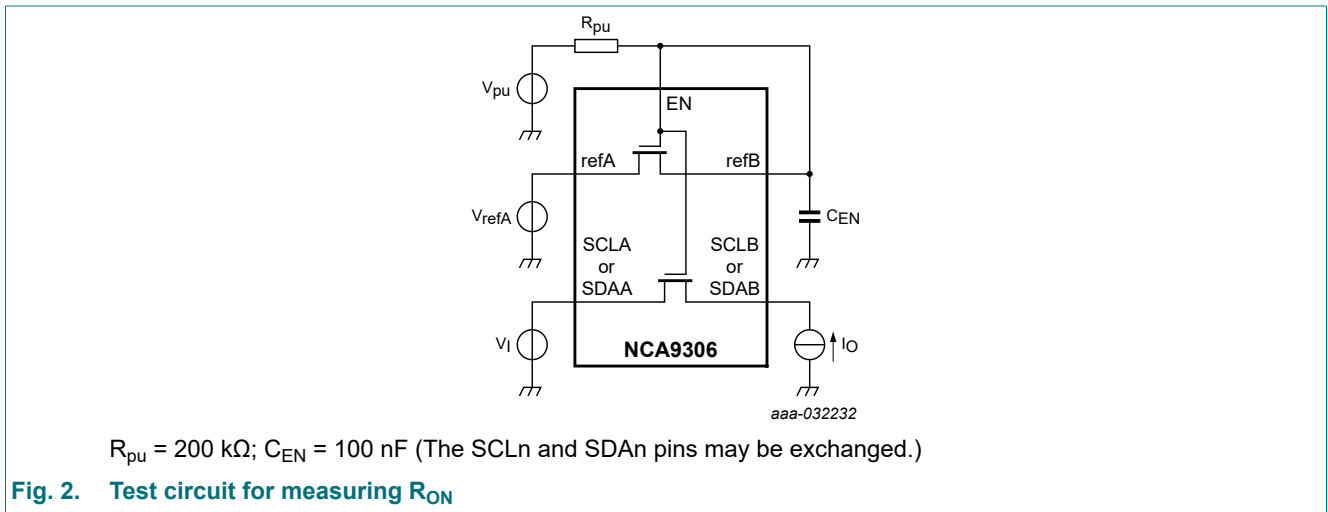

## 12. Dynamic characteristics

**Table 8. Switching characteristics**

$GND = 0\text{ V}$ ; for waveform see Fig. 3; for test circuit see Fig. 4

Symbol	Parameter	Conditions	$T_{\text{amb}} = -40\text{ °C to }+125\text{ °C}$			Unit
			Min	Typ[1]	Max	
<b>Translating down</b>						
$t_{\text{PLH}}$	LOW to HIGH propagation delay	SCLA, SDAA to SCLB, SDAB or SCLB, SDAB to SCLA, SDAA;				
		$V_{\text{IH}} = V_{\text{pu}} = V_{\text{refA}} + 1\text{ V}$				
		$V_{\text{refA}} = 1.5\text{ V}; C_{\text{L}} = 15\text{ pF}$	-	0.13	0.35	ns
		$V_{\text{refA}} = 1.5\text{ V}; C_{\text{L}} = 30\text{ pF}$	-	0.22	0.59	ns
		$V_{\text{refA}} = 1.5\text{ V}; C_{\text{L}} = 50\text{ pF}$	-	0.34	0.94	ns
		$V_{\text{refA}} = 2.3\text{ V}; C_{\text{L}} = 15\text{ pF}$	-	0.09	0.25	ns
		$V_{\text{refA}} = 2.3\text{ V}; C_{\text{L}} = 30\text{ pF}$	-	0.16	0.43	ns
		$V_{\text{refA}} = 2.3\text{ V}; C_{\text{L}} = 50\text{ pF}$	-	0.24	0.69	ns
$t_{\text{PHL}}$	HIGH to LOW propagation delay	SCLA, SDAA to SCLB, SDAB or SCLB, SDAB to SCLA, SDAA;				
		$V_{\text{IH}} = V_{\text{pu}} = V_{\text{refA}} + 1\text{ V}$				
		$V_{\text{refA}} = 1.5\text{ V}; C_{\text{L}} = 15\text{ pF}$	-	0.21	0.99	ns
		$V_{\text{refA}} = 1.5\text{ V}; C_{\text{L}} = 30\text{ pF}$	-	0.36	1.78	ns
		$V_{\text{refA}} = 1.5\text{ V}; C_{\text{L}} = 50\text{ pF}$	-	0.51	2.42	ns
		$V_{\text{refA}} = 2.3\text{ V}; C_{\text{L}} = 15\text{ pF}$	-	0.12	0.45	ns
		$V_{\text{refA}} = 2.3\text{ V}; C_{\text{L}} = 30\text{ pF}$	-	0.19	0.77	ns
		$V_{\text{refA}} = 2.3\text{ V}; C_{\text{L}} = 50\text{ pF}$	-	0.30	1.17	ns
<b>Translating up</b>						
$t_{\text{PLH}}$	LOW to HIGH propagation delay	SCLA, SDAA to SCLB, SDAB or SCLB, SDAB to SCLA, SDAA;				
		$V_{\text{IH}} = V_{\text{refA}}; V_{\text{EXT}} = V_{\text{pu}} = V_{\text{refA}} + 1\text{ V}$				
		$V_{\text{refA}} = 1.5\text{ V}; C_{\text{L}} = 15\text{ pF}$	-	0.06	0.11	ns
		$V_{\text{refA}} = 1.5\text{ V}; C_{\text{L}} = 30\text{ pF}$	-	0.14	0.32	ns
		$V_{\text{refA}} = 1.5\text{ V}; C_{\text{L}} = 50\text{ pF}$	-	0.26	0.58	ns
		$V_{\text{refA}} = 2.3\text{ V}; C_{\text{L}} = 15\text{ pF}$	-	0.06	0.13	ns
		$V_{\text{refA}} = 2.3\text{ V}; C_{\text{L}} = 30\text{ pF}$	-	0.13	0.28	ns
		$V_{\text{refA}} = 2.3\text{ V}; C_{\text{L}} = 50\text{ pF}$	-	0.20	0.50	ns
$t_{\text{PHL}}$	HIGH to LOW propagation delay	SCLA, SDAA to SCLB, SDAB or SCLB, SDAB to SCLA, SDAA;				
		$V_{\text{IH}} = V_{\text{refA}}; V_{\text{EXT}} = V_{\text{pu}} = V_{\text{refA}} + 1\text{ V}$				
		$V_{\text{refA}} = 1.5\text{ V}; C_{\text{L}} = 15\text{ pF}$	-	0.34	1.54	ns
		$V_{\text{refA}} = 1.5\text{ V}; C_{\text{L}} = 30\text{ pF}$	-	0.60	2.60	ns
		$V_{\text{refA}} = 1.5\text{ V}; C_{\text{L}} = 50\text{ pF}$	-	0.90	3.82	ns
		$V_{\text{refA}} = 2.3\text{ V}; C_{\text{L}} = 15\text{ pF}$	-	0.17	0.71	ns
		$V_{\text{refA}} = 2.3\text{ V}; C_{\text{L}} = 30\text{ pF}$	-	0.29	1.09	ns
		$V_{\text{refA}} = 2.3\text{ V}; C_{\text{L}} = 50\text{ pF}$	-	0.45	1.67	ns

[1] All typical values are measured at  $T_{\text{amb}} = 25\text{ °C}$ .

12.1. Waveforms and test circuit

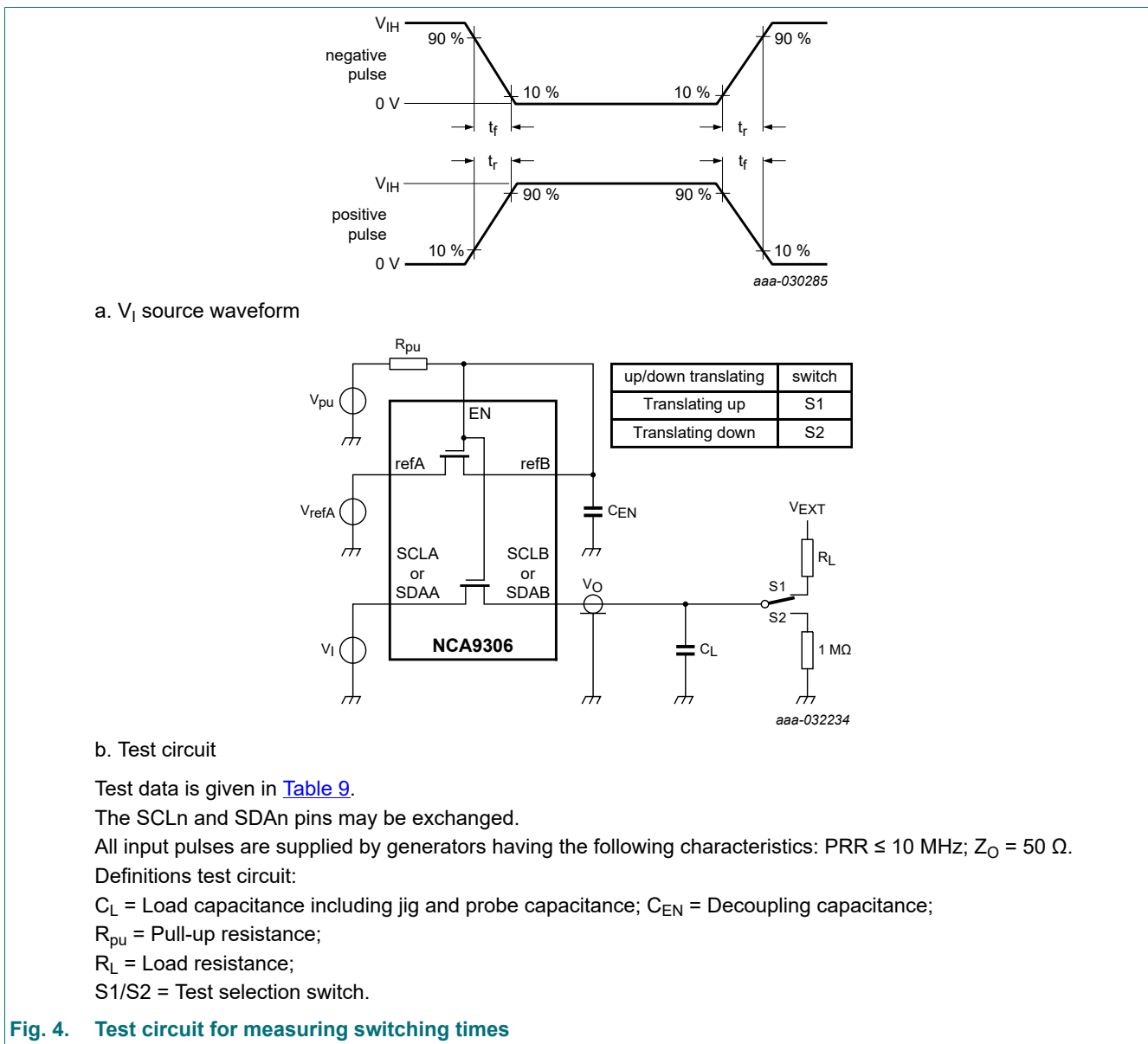
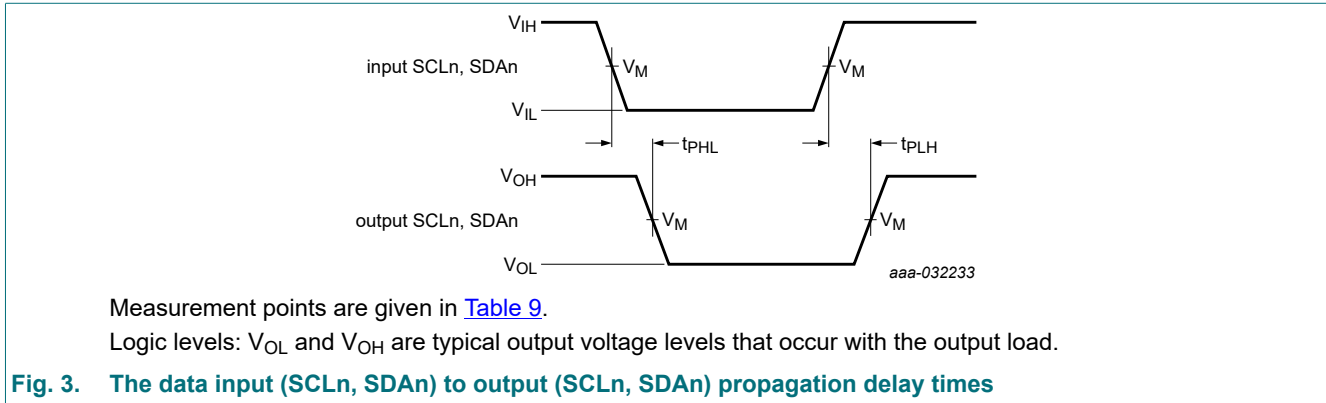

## 2-bit bidirectional multi-voltage level translator; open-drain; push-pull

Table 9. Test data

Input		Output	Load			
$t_r, t_f$	$V_M$	$V_M$	$C_L$	$C_{EN}$ [1]	$R_L$ [1]	$R_{pu}$
$\leq 2$ ns	$0.5V_{refA}$	$0.5V_{refA}$	15 pF, 30 pF, 50 pF	100 nF	300 $\Omega$	200 k $\Omega$

[1] All typical values are measured at  $T_{amb} = 25$  °C.

### 13. Package outline

TSSOP8: plastic thin shrink small outline package; 8 leads; body width 3 mm; lead length 0.5 mm SOT505-2

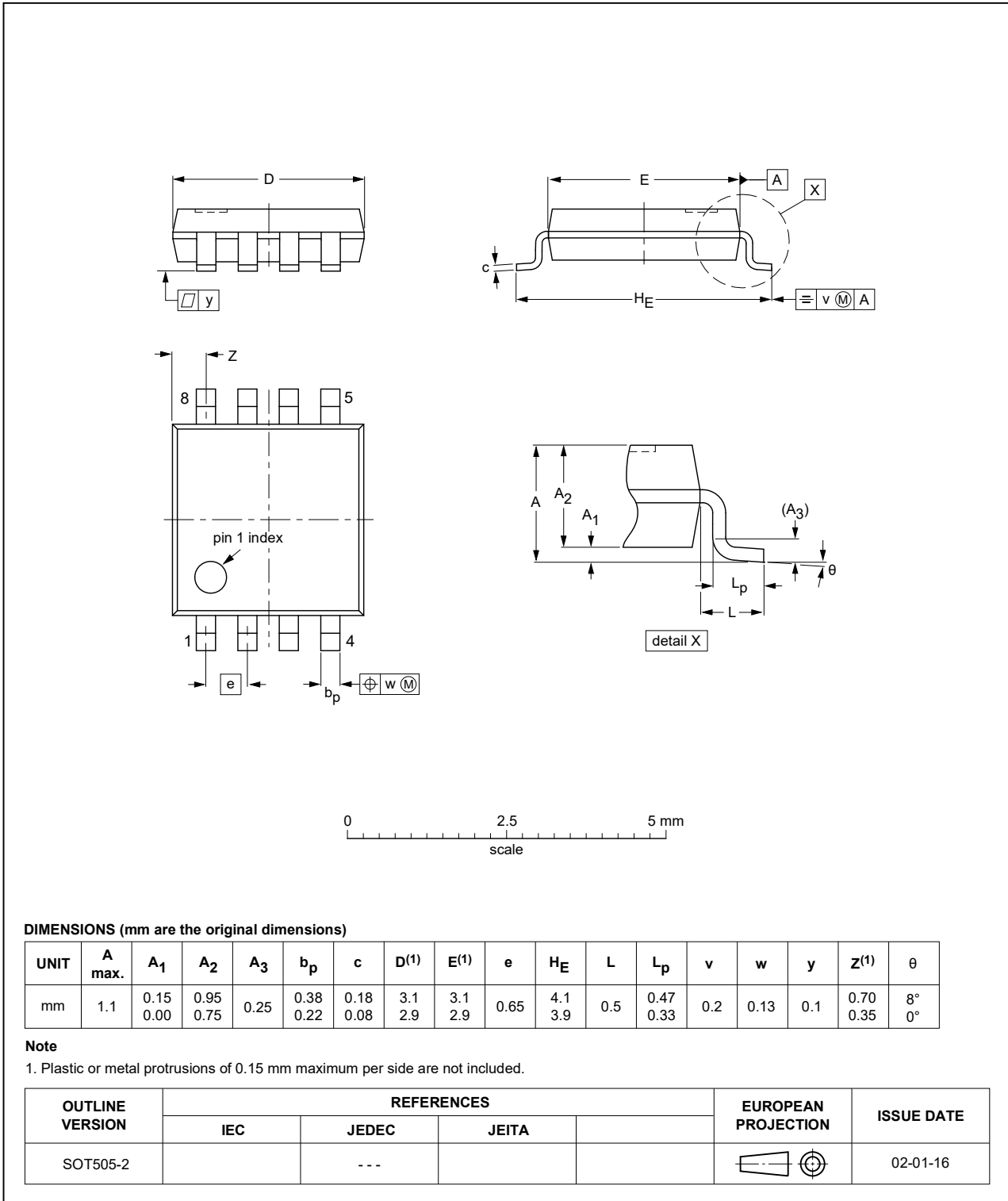

Fig. 5. Package outline SOT505-2 (TSSOP8)

2-bit bidirectional multi-voltage level translator; open-drain; push-pull

VSSOP8: plastic very thin shrink small outline package; 8 leads; body width 2.3 mm

SOT765-1



Fig. 6. Package outline SOT765-1 (VSSOP8)

XSON8: extremely thin small outline package; no leads;  
8 terminals; body 1.35 x 1.0 x 0.35 mm

SOT1203

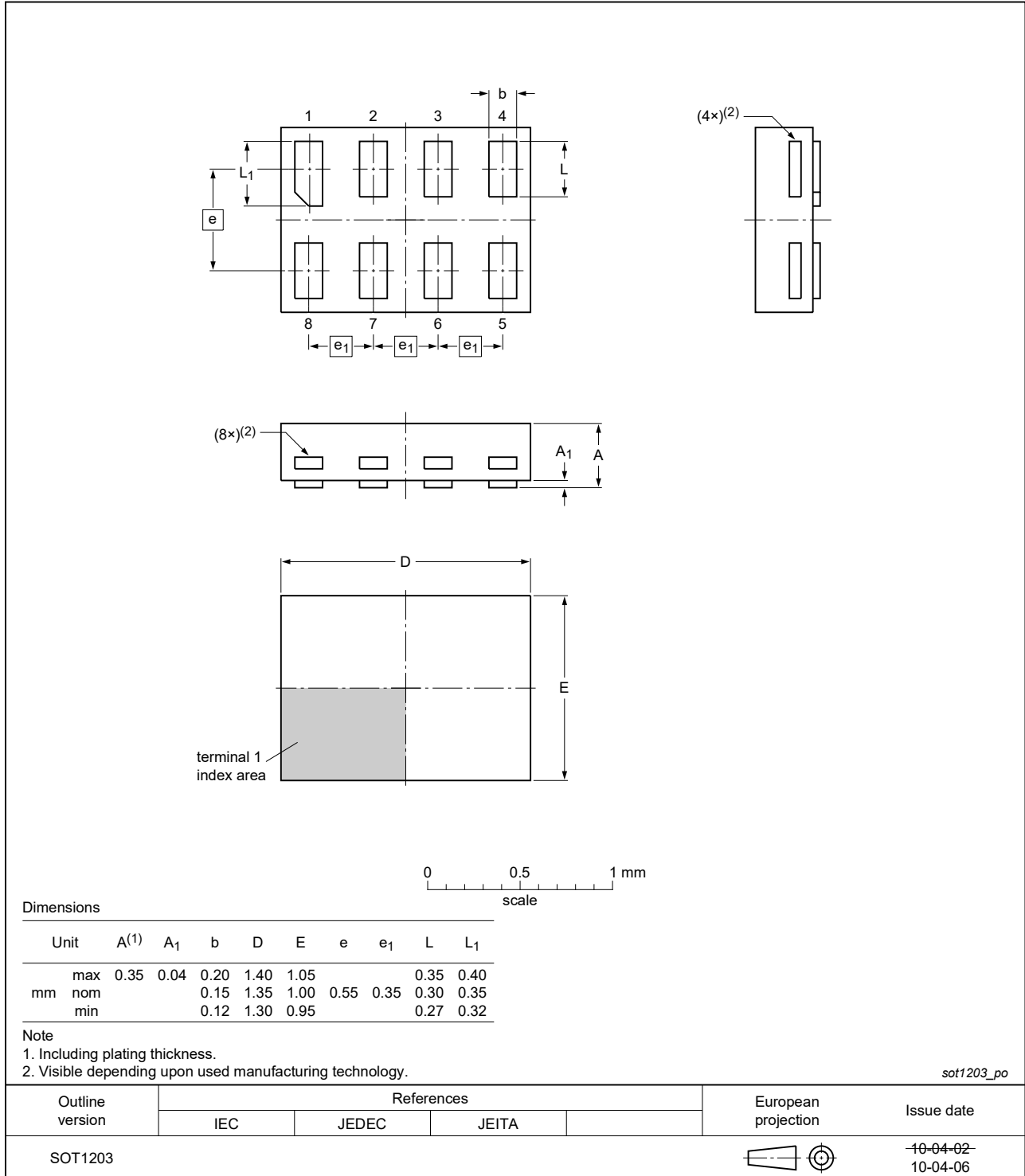

Fig. 7. Package outline SOT1203 (XSON8)

2-bit bidirectional multi-voltage level translator; open-drain; push-pull

X2SON8: plastic thermal enhanced extremely thin small outline package; no leads; 8 terminals; body 1.35 x 0.8 x 0.32 mm

SOT1233-2

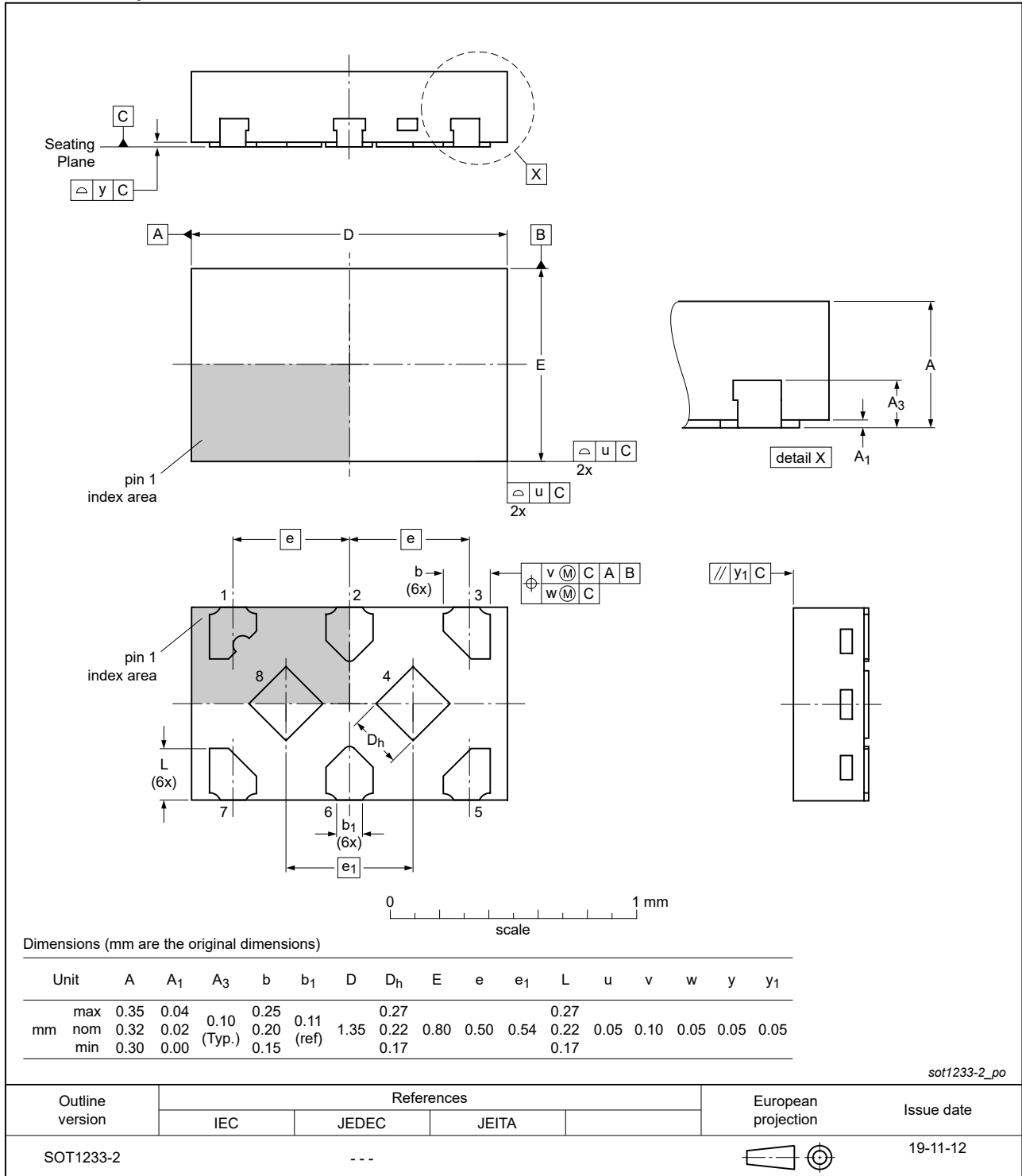

Fig. 8. Package outline SOT1233-2 (X2SON8)

## 14. Abbreviations

Table 10. Abbreviations

Acronym	Description
ANSI	American National Standards Institute
CDM	Charged Device Model
ESD	ElectroStatic Discharge
ESDA	ElectroStatic Discharge Association
HBM	Human Body Model
I <sup>2</sup> C	Inter-Integrated Circuit
JEDEC	Joint Electron Device Engineering Council
PMBus	Power Management Bus
PRR	Pulse Rate Repetition
SMBus	System Management Bus

## 15. Revision history

Table 11. Revision history

Document ID	Release date	Data sheet status	Change notice	Supersedes
NCA9306 v.3.1	20240805	Product data sheet	-	NCA9306 v.3
NCA9306 v.3	20240314	Product data sheet	-	NCA9306 v.2
Modifications:	<ul style="list-style-type: none"> <li>Type number NCA9306GS added.</li> </ul>			
NCA9306 v.2	20211126	Product data sheet	-	NCA9306 v.1
Modifications:	<ul style="list-style-type: none"> <li><a href="#">Table 3</a>: Typo corrected in the description of pin refB (errata).</li> </ul>			
NCA9306 v.1	20200922	Product data sheet	-	-

## 16. Legal information

### Data sheet status

Document status [1][2]	Product status [3]	Definition
Objective [short] data sheet	Development	This document contains data from the objective specification for product development.
Preliminary [short] data sheet	Qualification	This document contains data from the preliminary specification.
Product [short] data sheet	Production	This document contains the product specification.

- [1] Please consult the most recently issued document before initiating or completing a design.
- [2] The term 'short data sheet' is explained in section "Definitions".
- [3] The product status of device(s) described in this document may have changed since this document was published and may differ in case of multiple devices. The latest product status information is available on the internet at <https://www.nexperia.com>.

### Definitions

**Draft** — The document is a draft version only. The content is still under internal review and subject to formal approval, which may result in modifications or additions. Nexperia does not give any representations or warranties as to the accuracy or completeness of information included herein and shall have no liability for the consequences of use of such information.

**Short data sheet** — A short data sheet is an extract from a full data sheet with the same product type number(s) and title. A short data sheet is intended for quick reference only and should not be relied upon to contain detailed and full information. For detailed and full information see the relevant full data sheet, which is available on request via the local Nexperia sales office. In case of any inconsistency or conflict with the short data sheet, the full data sheet shall prevail.

**Product specification** — The information and data provided in a Product data sheet shall define the specification of the product as agreed between Nexperia and its customer, unless Nexperia and customer have explicitly agreed otherwise in writing. In no event however, shall an agreement be valid in which the Nexperia product is deemed to offer functions and qualities beyond those described in the Product data sheet.

### Disclaimers

**Limited warranty and liability** — Information in this document is believed to be accurate and reliable. However, Nexperia does not give any representations or warranties, expressed or implied, as to the accuracy or completeness of such information and shall have no liability for the consequences of use of such information. Nexperia takes no responsibility for the content in this document if provided by an information source outside of Nexperia.

In no event shall Nexperia be liable for any indirect, incidental, punitive, special or consequential damages (including - without limitation - lost profits, lost savings, business interruption, costs related to the removal or replacement of any products or rework charges) whether or not such damages are based on tort (including negligence), warranty, breach of contract or any other legal theory.

Notwithstanding any damages that customer might incur for any reason whatsoever, Nexperia's aggregate and cumulative liability towards customer for the products described herein shall be limited in accordance with the Terms and conditions of commercial sale of Nexperia.

**Right to make changes** — Nexperia reserves the right to make changes to information published in this document, including without limitation specifications and product descriptions, at any time and without notice. This document supersedes and replaces all information supplied prior to the publication hereof.

**Suitability for use** — Nexperia products are not designed, authorized or warranted to be suitable for use in life support, life-critical or safety-critical systems or equipment, nor in applications where failure or malfunction of an Nexperia product can reasonably be expected to result in personal

injury, death or severe property or environmental damage. Nexperia and its suppliers accept no liability for inclusion and/or use of Nexperia products in such equipment or applications and therefore such inclusion and/or use is at the customer's own risk.

**Quick reference data** — The Quick reference data is an extract of the product data given in the Limiting values and Characteristics sections of this document, and as such is not complete, exhaustive or legally binding.

**Applications** — Applications that are described herein for any of these products are for illustrative purposes only. Nexperia makes no representation or warranty that such applications will be suitable for the specified use without further testing or modification.

Customers are responsible for the design and operation of their applications and products using Nexperia products, and Nexperia accepts no liability for any assistance with applications or customer product design. It is customer's sole responsibility to determine whether the Nexperia product is suitable and fit for the customer's applications and products planned, as well as for the planned application and use of customer's third party customer(s). Customers should provide appropriate design and operating safeguards to minimize the risks associated with their applications and products.

Nexperia does not accept any liability related to any default, damage, costs or problem which is based on any weakness or default in the customer's applications or products, or the application or use by customer's third party customer(s). Customer is responsible for doing all necessary testing for the customer's applications and products using Nexperia products in order to avoid a default of the applications and the products or of the application or use by customer's third party customer(s). Nexperia does not accept any liability in this respect.

**Limiting values** — Stress above one or more limiting values (as defined in the Absolute Maximum Ratings System of IEC 60134) will cause permanent damage to the device. Limiting values are stress ratings only and (proper) operation of the device at these or any other conditions above those given in the Recommended operating conditions section (if present) or the Characteristics sections of this document is not warranted. Constant or repeated exposure to limiting values will permanently and irreversibly affect the quality and reliability of the device.

**Terms and conditions of commercial sale** — Nexperia products are sold subject to the general terms and conditions of commercial sale, as published at <http://www.nexperia.com/profile/terms>, unless otherwise agreed in a valid written individual agreement. In case an individual agreement is concluded only the terms and conditions of the respective agreement shall apply. Nexperia hereby expressly objects to applying the customer's general terms and conditions with regard to the purchase of Nexperia products by customer.

**No offer to sell or license** — Nothing in this document may be interpreted or construed as an offer to sell products that is open for acceptance or the grant, conveyance or implication of any license under any copyrights, patents or other industrial or intellectual property rights.

**Export control** — This document as well as the item(s) described herein may be subject to export control regulations. Export might require a prior authorization from competent authorities.

**Non-automotive qualified products** — Unless this data sheet expressly states that this specific Nexperia product is automotive qualified, the product is not suitable for automotive use. It is neither qualified nor tested in accordance with automotive testing or application requirements. Nexperia accepts no liability for inclusion and/or use of non-automotive qualified products in automotive equipment or applications.

In the event that customer uses the product for design-in and use in automotive applications to automotive specifications and standards, customer (a) shall use the product without Nexperia's warranty of the product for such automotive applications, use and specifications, and (b) whenever customer uses the product for automotive applications beyond Nexperia's specifications such use shall be solely at customer's own risk, and (c) customer fully indemnifies Nexperia for any liability, damages or failed product claims resulting from customer design and use of the product for automotive applications beyond Nexperia's standard warranty and Nexperia's product specifications.

**Translations** — A non-English (translated) version of a document is for reference only. The English version shall prevail in case of any discrepancy between the translated and English versions.

### Trademarks

Notice: All referenced brands, product names, service names and trademarks are the property of their respective owners.

## Contents

---

<b>1. General description</b> .....	<b>1</b>
<b>2. Features and benefits</b> .....	<b>1</b>
<b>3. Applications</b> .....	<b>2</b>
<b>4. Ordering information</b> .....	<b>2</b>
<b>5. Marking</b> .....	<b>2</b>
<b>6. Functional diagram</b> .....	<b>2</b>
<b>7. Pinning information</b> .....	<b>3</b>
7.1. Pinning.....	3
7.2. Pin description.....	3
<b>8. Functional description</b> .....	<b>3</b>
<b>9. Limiting values</b> .....	<b>4</b>
<b>10. Recommended operating conditions</b> .....	<b>4</b>
<b>11. Static characteristics</b> .....	<b>4</b>
<b>12. Dynamic characteristics</b> .....	<b>6</b>
12.1. Waveforms and test circuit.....	7
<b>13. Package outline</b> .....	<b>9</b>
<b>14. Abbreviations</b> .....	<b>13</b>
<b>15. Revision history</b> .....	<b>13</b>
<b>16. Legal information</b> .....	<b>14</b>

---

© Nexperia B.V. 2024. All rights reserved

For more information, please visit: <http://www.nexperia.com>

For sales office addresses, please send an email to: [salesaddresses@nexperia.com](mailto:salesaddresses@nexperia.com)

Date of release: 5 August 2024

---

## Looking for pricing, stock, or lifecycle information?

Click below to explore more details on WIN SOURCE:

- [View MB85RS64TPN-G-AMEWE1 on WIN SOURCE](#)
- [Fujitsu Electronics America, Inc. Information](#)

## Optimize Your Supply Chain with WIN SOURCE Solutions

- ✓ Global Sourcing Solution
- ✓ Obsolete Management
- ✓ Cost Control Management
- ✓ Shortage Management
- ✓ Alternative Solution
- ✓ Excess Inventory Management