



**THE DATASHEET OF
NINA-B112-03B**



NEO-F10N

Standard precision GNSS module

Professional grade

Data sheet



Abstract

This Data sheet describes the NEO-F10N module, an L1/L5 dual-band GNSS receiver for meter-level accuracy in urban environment.

Note! GPS L5 signals are pre-operational and not used by default. Refer to the Overview section for more information.

Document information

Title	NEO-F10N	
Subtitle	Standard precision GNSS module	
Document type	Data sheet	
Document number	UBX-23002117	
Revision and date	R05	09-Oct-2025
Disclosure restriction	C1-Public	

Product status	Corresponding content status	
Functional sample	Draft	For functional testing. Revised and supplementary data will be published later.
In development / prototype	Objective specification	Target values. Revised and supplementary data will be published later.
Engineering sample	Advance information	Data based on early testing. Revised and supplementary data will be published later.
Initial production	Early production information	Data from product verification. Revised and supplementary data may be published later.
Mass production / End of life	Production information	Document contains the final product specification.

This document applies to the following products:

Product name	Type number	FW version	IN/PCN reference	Product status
NEO-F10N	NEO-F10N-00B-00	EXT SPG 6.00	UBXDOC-304424225-18225 UBXDOC-963802114-12646	Mass production
NEO-F10N	NEO-F10N-00B-20	EXT SPG 6.00	UBXDOC-304424225-18225 UBXDOC-963802114-12646	Mass production

u-blox or third parties may hold intellectual property rights in the products, names, logos and designs included in this document. Copying, reproduction, or modification of this document or any part thereof is only permitted with the express written permission of u-blox. Disclosure to third parties is permitted for clearly public documents only.

The information contained herein is provided "as is" and u-blox assumes no liability for its use. No warranty, either express or implied, is given, including but not limited to, with respect to the accuracy, correctness, reliability and fitness for a particular purpose of the information. This document may be revised by u-blox at any time without notice. For the most recent documents and product statuses, visit www.u-blox.com.

Copyright © 2025, u-blox AG.

Contents

Document information.....	2
Contents.....	3
1 Functional description.....	4
1.1 Overview.....	4
1.2 Performance.....	4
1.3 Supported GNSS constellations.....	5
1.4 Broadcast navigation data and satellite signal measurements.....	6
1.5 Supported protocols.....	6
1.6 Firmware features.....	6
2 Block diagram.....	8
3 Pin definition.....	9
3.1 Pin assignment.....	9
3.2 Pin state.....	10
4 Electrical specifications.....	11
4.1 Absolute maximum ratings.....	11
4.2 Operating conditions.....	11
4.3 Indicative power requirements.....	12
5 Communication interfaces.....	14
5.1 UART.....	14
5.2 Default interface settings.....	14
6 Mechanical specifications.....	15
7 Qualifications and approvals.....	16
8 Product handling.....	17
8.1 Packaging.....	17
8.1.1 Reels.....	17
8.1.2 Tapes.....	17
8.2 Soldering.....	17
9 Product marking and ordering information.....	18
9.1 Product marking.....	18
9.2 Product identifiers.....	18
9.3 Ordering codes.....	19
Related documents.....	20
Revision history.....	21
Contact.....	22

1 Functional description

1.1 Overview

The NEO-F10N is built on the u-blox F10 dual-band GNSS technology using the L1 and L5 band signals. The proprietary dual-band multipath mitigation technology enables the u-blox F10 to use the best signals from the L1 and L5 bands providing a solid meter-level position accuracy in urban environment.

NEO-F10N-00B-20 supports GNSS broadcast data and raw carrier-phase measurements.

- ⚠ At the time of writing, the GPS L5 signals remain pre-operational and are set as unhealthy until sufficient monitoring capability is established. This is an operational issue concerning the satellites / space segment and not a limitation of u-blox products.
- ⚠ Due to the pre-operational status, the GPS L5 signals are not used for the navigation solution by default. However, it is possible to evaluate the GPS L5 signals before they become fully operational by changing the receiver configuration to override the GPS L5 health status. Refer to the Integration manual [1] for details.

1.2 Performance

Parameter	Specification	Value
Receiver type		u-blox F10 dual-band receiver
Accuracy of time pulse signal	RMS	30 ns
	99%	60 ns
Frequency of time pulse signal		Default 1PPS (0.25 Hz to 10 MHz configurable)
Operational limits ¹	Dynamics	≤ 4 g
	Altitude	80,000 m
	Velocity	500 m/s
Velocity accuracy ²		0.05 m/s
Dynamic heading accuracy ²		0.3 deg

Table 1: NEO-F10N specifications

Table 2 shows typical performance values in multi-GNSS configurations³. SBAS is enabled in all measurements.

Parameter	GPS+GAL +BDS (Default)	GPS+BDS	GPS+GAL	GPS+NavIC	Unit
Max navigation update rate ⁴	10	10	10	10	Hz
Position accuracy (CEP) ⁵	1	1	1	1	m
Time To First Fix (TTFF) ⁶	Cold start	28	28	27	s
	Hot start	2	2	2	s

¹ Assuming Airborne 4 g platform.

² 50% at 30 m/s for dynamic operation.

³ The GPS L5 signal is included in the performance figures. Note that this signal is not fully operational yet and using it requires a configuration change.

⁴ Minimum 98% fix rate under typical conditions.

⁵ CEP, 50%, 24 hours static, -130 dBm, > 6 SVs for each GNSS system.

⁶ Commanded starts. All satellites signals at -130 dBm. Measured at room temperature.

Parameter		GPS+GAL +BDS (Default)	GPS+BDS	GPS+GAL	GPS+NavIC	Unit
	AssistNow Online ⁷	2	2	2	2	s
	AssistNow Offline ⁸	3	3	3	3	s
	AssistNow Autonomous ⁹	4	4	4	4	s
Sensitivity ¹⁰	Tracking and navigation	-167	-167	-167	-167	dBm
	Reacquisition	-159	-159	-159	-159	dBm
	Cold Start	-148	-148	-148	-148	dBm
	Hot start	-159	-159	-159	-159	dBm

Table 2: NEO-F10N typical performance in multi-GNSS configurations

Table 3 shows typical performance values in single-GNSS configurations³. SBAS is enabled in all measurements.

Parameter		GPS	BDS	Unit
Max navigation update rate ⁴		20	20	Hz
Position accuracy (CEP) ⁵		1.5	1	m
Time To First Fix (TTFF) ⁶	Cold start	27	42	s
	Hot start	2	2	s
	AssistNow Online ⁷	2	N/A	s
Sensitivity ¹⁰	Tracking and navigation	-167	-163	dBm
	Reacquisition	-159	-156	dBm
	Cold Start	-148	-137	dBm
	Hot start	-159	-157	dBm

Table 3: NEO-F10N typical performance in single-GNSS configurations

1.3 Supported GNSS constellations

NEO-F10N is a concurrent GNSS receiver that can receive and track multiple GNSS systems. The dual-band RF front-end architecture enables concurrent reception of multiple dual frequency GNSS constellations. To achieve lower power consumption, the receiver can be configured for a subset of GNSS constellations.

The default configuration on NEO-F10N is concurrent reception of GPS, Galileo and BeiDou with SBAS (EGNOS, GAGAN, MSAS, and WAAS) enabled.



Single-band operation is not supported. Both L1 and L5 signals must be enabled or disabled for GPS, Galileo, BeiDou, and QZSS.

The following GNSS and their signals are supported:

System	Signals
GPS / QZSS	L1C/A (1575.42 MHz), L5 (1176.450 MHz)
Galileo	E1-B/C (1575.42 MHz), E5a (1176.450 MHz)
BeiDou	B1C (1575.42 MHz) , B2a (1176.450 MHz)

⁷ Depends on the speed and latency of the aiding data connection, commanded starts.

⁸ Using seven days old AssistNow Offline data. External memory may be required.

⁹ Using two days old orbital predicted data. External memory may be required.

¹⁰ Demonstrated with a good external LNA. Measured at room temperature.

System	Signals
NavIC	SPS-L5 (1176.450 MHz)

Table 4: Supported GNSS and signals on NEO-F10N

The following GNSS assistance services are supported:

Service	Support
AssistNow Online	GPS L1C/A, Galileo E1, QZSS L1C/A
AssistNow Offline	GPS L1C/A, Galileo E1, QZSS L1C/A
AssistNow Autonomous	GPS L1C/A, Galileo E1

Table 5: Supported Assisted GNSS (A-GNSS) services

The following augmentation systems are supported:

System	Support
SBAS ¹¹	EGNOS, GAGAN, MSAS, WAAS, BDSBAS, KASS and SouthPAN
QZSS	L1S (SLAS), L1Sb (SBAS)

Table 6: Supported augmentation systems

 The QZSS augmentation system can be enabled only if GPS operation is also enabled.

1.4 Broadcast navigation data and satellite signal measurements

The GNSS broadcast data is available in the UBX-RXM-SFRBX message for all supported GNSS signals as well as the QZSS and SBAS augmentation services. The satellite signal information is compatible with the Radio Resource LCS Protocol (RRLP) [4].

The full raw data including code phase, doppler, pseudorange, carrier phase, and measurement quality information is available in the UBX-RXM-RAWX message for all supported GNSS signals. The UBX-RXM-RAWX message follows the conventions of a multi-GNSS RINEX 3 observation file.

This applies only to the product NEO-F10N-00B-20.

 The raw measurement data is available after the receiver has established data bit synchronization and time-of-week.

1.5 Supported protocols

NEO-F10N supports the following interface protocols:

Protocol	Type
UBX	Input/output, binary, u-blox proprietary
NMEA versions 2.1, 2.3, 4.0, 4.10 and 4.11 (default)	Input/output, ASCII

Table 7: Supported protocols

1.6 Firmware features

Feature	Description
Assisted GNSS	AssistNow Online, AssistNow Offline and AssistNow Autonomous

¹¹ Ionospheric correction service is the only SBAS service supported by NEO-F10N

Feature	Description
Backup modes	Hardware backup mode and software standby mode
Protection level	Real-time position accuracy estimate with 95% confidence level ¹²
Galileo return link messages	Galileo search and rescue (SAR) return link messages (RLM) via Galileo satellite signal
Carrier phase output ¹³	GNSS broadcast data and raw carrier-phase measurements
Odometer	Measure traveled distance with support for different user profiles

Table 8: Firmware features

Feature	Description
Anti-jamming	RF interference and jamming detection and reporting
Anti-spoofing	Spoofing detection and reporting
Configuration lockdown	Receiver configuration can be locked by command
Message integrity	All messages can be cryptographically signed
Secure boot	Only signed firmware images are executed

Table 9: Security features

¹² Verified for automotive environment only.

¹³ Applies only to the product NEO-F10N-00B-20.

2 Block diagram

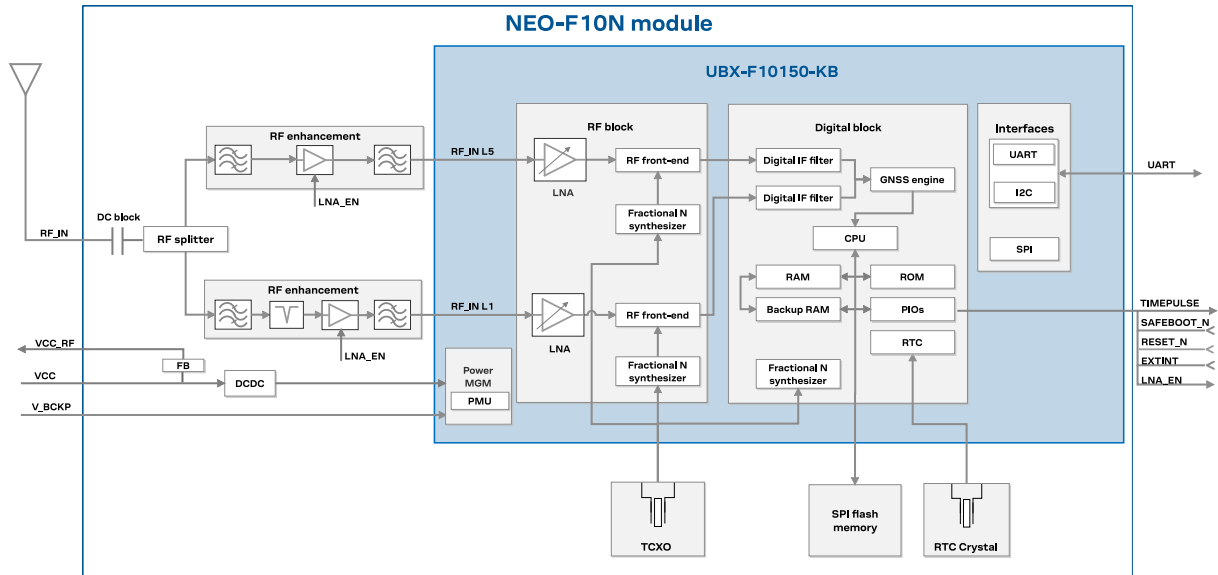

Figure 1: NEO-F10N block diagram

3 Pin definition

3.1 Pin assignment

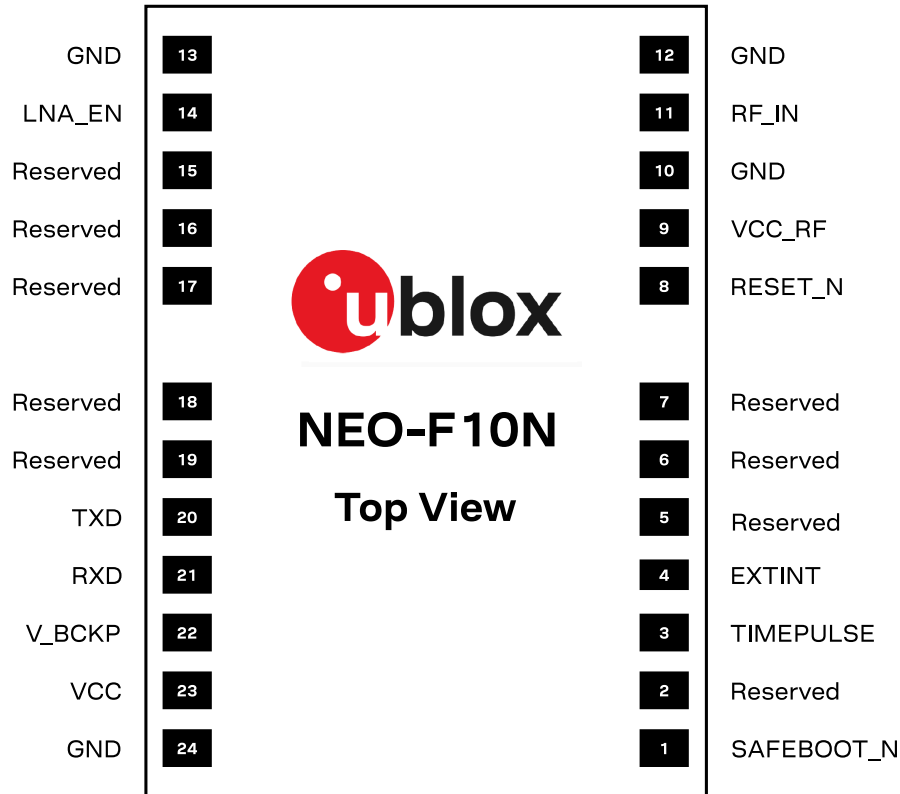

Figure 2: NEO-F10N pin assignment

Pin no.	Name	I/O	Description
1	SAFEBOOT_N	I	Safeboot mode. If not used, leave open. ¹⁴
2	Reserved	-	Not connected
3	TIMEPULSE	O	Time pulse signal (shared with SAFEBOOT_N pin) ¹⁴
4	EXTINT	I	External interrupt
5	Reserved	-	Not connected
6	Reserved	-	Not connected
7	Reserved	-	Not connected
8	RESET_N	I	RESET (active low)
9	VCC_RF	O	Output voltage RF section
10	GND	-	Ground
11	RF_IN	I	GNSS signal input
12	GND	-	Ground
13	GND	-	Ground

¹⁴ The receiver enters safeboot mode if SAFEBOOT_N pin is low at start up. The SAFEBOOT_N pin is internally connected to TIMEPULSE pin through a 1 kΩ series resistor.

Pin no.	Name	I/O	Description
14	LNA_EN	O	On/Off internal LNAs and an optional external LNA or an active antenna
15	Reserved	-	Not connected
16	Reserved	-	Not connected
17	Reserved	-	Not connected
18	Reserved	-	Not connected
19	Reserved	-	Not connected
20	TXD	O	UART TX
21	RXD	I	UART RX
22	V_BCKP	I	Backup voltage supply
23	VCC	I	Supply voltage
24	GND	-	Ground

Table 10: NEO-F10N pin assignment

3.2 Pin state

Table 11 defines the state of the interface pins in different modes.

Pin no.	Function	Continuous mode	Software standby mode	Safe boot mode
21	RXD	Input pull-up	Input pull-up	Input pull-up
20	TXD	Output	Input pull-up	Output
1	SAFEBOOT_N ¹⁴	Output	Input pull-up	Output (low)
3	TIMEPULSE	Output	Input pull-up	Output (low)
8	RESET_N	Input pull-up	Input pull-up	Input pull-up
4	EXTINT	Input pull-up	Input pull-up	Input pull-up
14	LNA_EN ¹⁵	Output (high)	Output (low)	Output (high)

Table 11: Pin state

In the reset mode (RESET_N = low), all interface pins are configured as input pull-ups.



Do not drive pins in the hardware backup mode (VCC = 0 V).

¹⁵ LNA_EN signal is connected through a buffer circuit with 100 kΩ pull-down resistor to GND.

4 Electrical specifications

4.1 Absolute maximum ratings

- ⚠ CAUTION. Risk of device damage. Exceeding the absolute maximum ratings may affect the lifetime and reliability of the device or permanently damage it. Do not exceed the absolute maximum ratings.
- ⚠ This product is not protected against overvoltage or reversed voltages. Use appropriate protection to avoid device damage from voltage spikes exceeding the specified boundaries.

Symbol	Parameter	Min	Max	Unit
VCC	Main supply voltage	-0.3	3.6	V
	Voltage ramp on VCC ¹⁶	25	35000	μs/V
V_BCKP	Backup supply voltage	-0.3	3.6	V
V_PIO	Input voltage on RESET_N and digital pins	-0.3	VCC + 0.3 (max 3.6)	V
I_PIO	Max source / sink current, digital pins ¹⁷	-10	10	mA
ICC_RF	Max source current, VCC_RF		250	mA
V_DC _{rfin}	DC voltage at RF_IN	-5.5	+5.5	V
P _{rfin}	RF input power at RF_IN ^{18, 19}		0	dBm
T _{amb}	Ambient temperature	-40	+85	°C
T _s	Storage temperature	-40	+85	°C

Table 12: Absolute maximum ratings

4.2 Operating conditions

Table 13 shows the general operating conditions. Table 14 shows the electrical parameters for digital I/O.

Symbol	Parameter	Min	Typical	Max	Unit
VCC	Main supply voltage	2.7	3.0	3.6	V
V_BCKP	Supply voltage, backup domain	1.65		3.6	V
VCC _{SWITCH}	VCC voltage threshold to switch an internal supply for the backup domain from VCC to V_BCKP		1.45		V
VCC_RF	VCC_RF output voltage		VCC - 0.1		V
ICC_RF	VCC_RF output current			50	mA
Z _{in} ²⁰	Input impedance at RF_IN		50		Ω
NF _{tot}	Receiver chain noise figure (L1)		3		dB
	Receiver chain noise figure (L5)		3		dB
Ext_gain ²¹	External gain at RF_IN, low gain mode (default)			25	dB

¹⁶ Exceeding the voltage ramp speed may permanently damage the device.

¹⁷ The SAFEBOOT_N pin has an internal 1 kΩ series resistor.

¹⁸ Test conditions: source impedance = 50 Ω, continuous wave.

¹⁹ +15 dBm for outband; 0 dBm for inband

²⁰ The RF_IN input integrates a built-in DC block.

²¹ The internal LNA gain is configurable.

Symbol	Parameter	Min	Typical	Max	Unit
T_{opr}	Operating temperature	-40		+85	°C

Table 13: General operating conditions

Symbol	Parameter	Min	Typical	Max	Unit
I_{leak}	Leakage current input pins ²²		25		nA
V_{in}	Input pin voltage range	0		VCC	V
V_{il}	Low-level input voltage			0.63	V
V_{ih}	High-level input voltage	0.68 x VCC			V
V_{ol}	Low-level output voltage, $I_{out} = -2$ mA ^{15, 23}			0.4	V
V_{oh}	High-level output voltage, $I_{out} = 2$ mA ^{15, 23}	VCC - 0.4			V
$R_{pu, IO}$	Pull-up resistance, Digital IO	8	18	40	kΩ
$R_{pd, IO}$	Pull-down resistance, Digital IO	21	80	180	kΩ
$R_{pu, SAFEBOOT_N}$	Pull-up resistance, SAFEBOOT_N ²⁴	6	17	72	kΩ
$R_{pu, RESET_N}$	Pull-up resistance, RESET_N	7	10	13	kΩ

Table 14: Digital IO

4.3 Indicative power requirements

This section provides examples of typical current requirements. They have been characterized on samples using a cold start command. The actual power requirements may vary depending on the firmware version used, the external circuitry, the number of satellites tracked, the signal strength, the type and time of start, duration, internal LNA gain mode, and the test conditions.

All values in [Table 15](#) and [Table 16](#) have been measured at 25 °C ambient temperature with the default configuration unless otherwise stated. SBAS is active in all measurements.

[Table 15](#) shows indicative current consumption for VCC with a 3.0 V supply.

Symbol (Parameter)	Conditions	GPS+GAL +BDS (Default)	GPS+BDS	GPS+GAL	GPS +NavIC	GPS	BDS	Unit
I_{VCC} ²⁵	Acquisition ²⁶	26	26	22	21	20	24	mA
(VCC current)	Tracking	21	20	19	18	18	19	mA

Table 15: Typical currents for 3.0 V supply at VCC

The inrush current can go up to 100 mA at startup. Ensure that the external power supply is able to deliver up to 100 mA.

[Table 16](#) shows current consumption for backup modes.

Symbol	Parameter	Conditions	Typical	Unit
I_{V_BCKP} ²⁷	Total current in hardware backup mode	$V_BCKP = 3.0$ V; $VCC = 0$ V	31	μA

²² $V_{in} = VCC$, at room temperature.

²³ TIMEPULSE has 4 mA current drive/sink capability.

²⁴ The SAFEBOOT_N pin has an additional 1 kΩ series resistor.

²⁵ 1 Hz navigation update rate. Simulated signals using power levels of -130 dBm.

²⁶ Average current from start-up until the first fix.

²⁷ I_{V_BCKP} current in normal operation ($V_BCKP = 3.0$ V) is ~3 μA.

Symbol	Parameter	Conditions	Typical	Unit
I_{VCC}	Total current in software standby mode	VCC = 3.0 V	49	μA

Table 16: Backup currents

Extreme operating temperatures can significantly impact the specified values. If an application operates near the min or max temperature limits, ensure the specified values are not exceeded.

5 Communication interfaces

The receiver supports communication over the UART only.

All the inputs have an internal pull-up resistor in normal operation and can be left open if not used. The voltage level at the PIO pins is related to the VCC supply voltage.

5.1 UART

The UART interface supports configurable baud rates. Hardware flow control is not supported. UART specifications are described in [Table 17](#).

Symbol	Parameter	Min	Max	Unit
R_u	Baud rate	9600	921600	bit/s
Δ_{Tx}	Tx baud rate accuracy	-1%	+1%	-
Δ_{Rx}	Rx baud rate tolerance	-2.5%	+2.5%	-

Table 17: UART specifications

5.2 Default interface settings

Interface	Settings
UART	<ul style="list-style-type: none"> 38400 baud²⁸, 8 bits, no parity bit, 1 stop bit. Input messages: NMEA and UBX Output messages: NMEA GGA, GLL, GSA, GSV, RMC, VTG and TXT

Table 18: Default interface settings

²⁸ 9600 baud in the safe boot mode.

6 Mechanical specifications

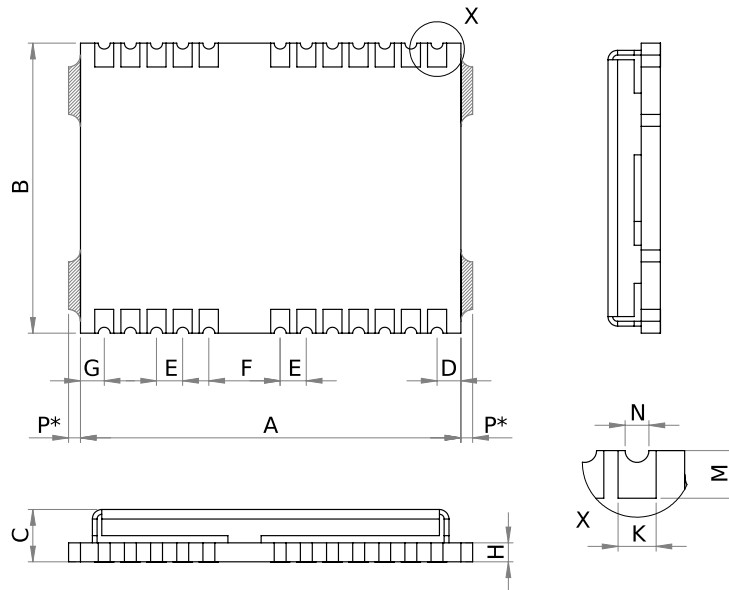

Figure 3: NEO-F10N mechanical drawing

Symbol	Min (mm)	Typical (mm)	Max (mm)	
A	15.9	16.0	16.1	
B	12.1	12.2	12.3	
C	2.2	2.4	2.6	
D	0.9	1.0	1.1	
E	1.0	1.1	1.2	
F	2.9	3.0	3.1	
G	0.9	1.0	1.1	
H	-	0.82	-	
K	0.7	0.8	0.9	
M	0.8	0.9	1.0	
N	0.4	0.5	0.6	
P*	0.0	-	0.5	The de-paneling residual tabs may be on either side (not both).
Weight		1.0 g		

Table 19: NEO-F10N mechanical dimensions



The mechanical picture of the de-paneling residual tabs (P*) is an approximate representation, shape and position may vary.



Component keep-out area must consider that the de-paneling residual tabs can be on either side (not both).

7 Qualifications and approvals

Type	Description
Quality and reliability	
Product qualification	Qualified according to u-blox qualification policy, based on a subset of AEC-Q104
Manufacturing	Manufactured at IATF 16949 certified sites
Environmental	
RoHS compliance	Yes
Moisture sensitivity level (MSL) ^{29, 30}	4
Type approvals	
European RED certification (CE)	Declaration of Conformity (DoC) is available on the u-blox website .
UK conformity assessment (UKCA)	Yes

Table 20: Qualifications and approvals

²⁹ For MSL standard see IPC/JEDEC J-STD-020 and J-STD-033 [6].

³⁰ For more information regarding moisture sensitivity levels, labeling, storage, and drying, see the Product packaging reference guide [5].

8 Product handling

8.1 Packaging

The NEO-F10N modules are delivered as hermetically sealed, reeled tapes to enable efficient production, production lot set-up and tear-down. For more information, see the Product packaging reference guide [5].

8.1.1 Reels

NEO-F10N modules are deliverable in quantities of 500 pieces on a reel. They are shipped on reel type A3, as specified in the Product packaging reference guide [5].

8.1.2 Tapes

Figure 4 shows the feed direction, orientation and dimensions of the NEO-F10N modules on the tape (measurements in mm).

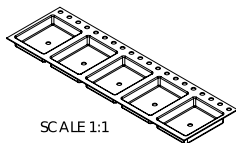
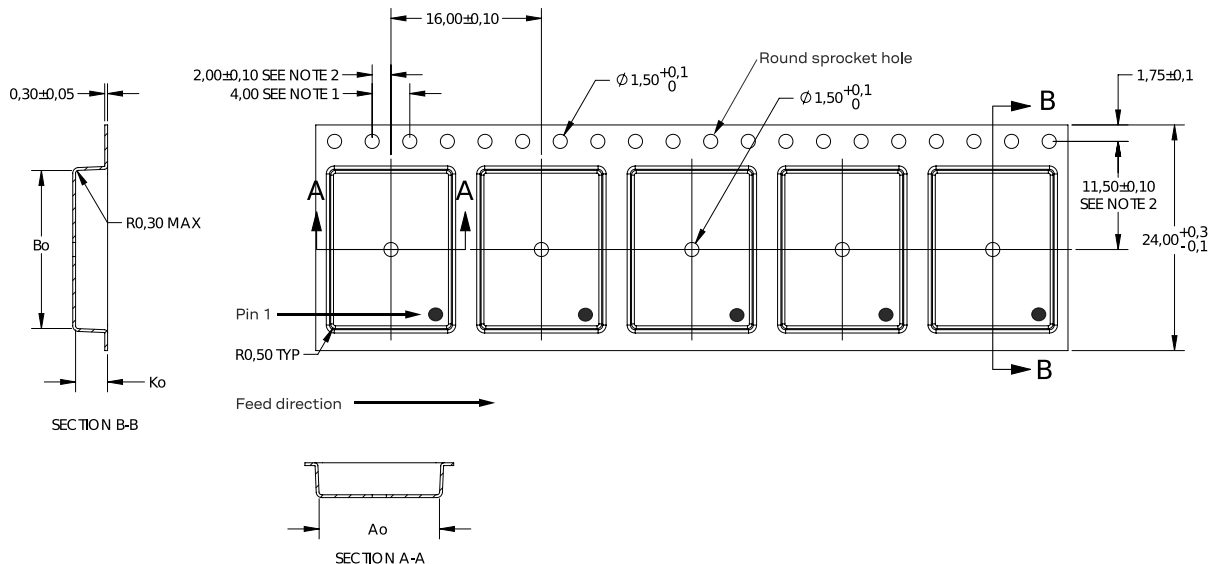

- NOTES:
1. 10 SPROCKET HOLE PITCH CUMULATIVE TOLERANCE ± 0.2
 2. POCKET POSITION RELATIVE TO SPROCKET HOLE MEASURED AS TRUE POSITION OF POCKET, NOT POCKET HOLE.
 3. Ao AND Bo ARE MEASURED ON A PLANE AT A DISTANCE "R" ABOVE THE BOTTOM OF THE POCKET.

Figure 4: Tape specification

8.2 Soldering

Reflow soldering is described in the IPC/JEDEC J-STD-020 standard [6].

9 Product marking and ordering information

This section provides information about product marking and ordering.

9.1 Product marking

The product marking provides information on NEO-F10N and its revision, as in [Figure 5](#). For a description of the product marking, see [Table 21](#)

The product marking is done by laser etching on the NEO-F10N module metal shield cover.

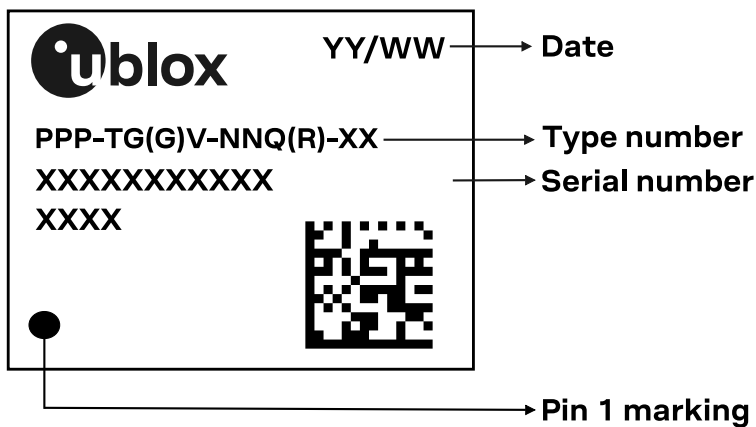

Figure 5: Example of NEO-F10N product marking

Code	Meaning	Example
PPP	Form factor	NEO
TGG	Platform	F10 = u-blox F10
V	Variant	N = Standard precision, flash, TCXO, SAW filter, and LNA
NN	Major product version	00, 01, 02, ...
Q	Product grade	A = Automotive, B = Professional
XX	Revision	Hardware and firmware versions
(R)	Production site	No character = global, 1 = regional variant
XXXXXXXXXXXX	Serial number	Alphanumeric characters, e.g. BN600001181
YYWW	Production date	Year/week, e.g. 2404

Table 21: Description of product marking

9.2 Product identifiers

The NEO-F10N marking features three product identifiers: product name, ordering code and type number. The product name identifies all u-blox products, independent of packaging and product grade, and it is used in documentation such as this data sheet. The ordering code includes the major product version and product grade, while the type number additionally includes the hardware and firmware versions.

[Table 22](#) describes the three different product identifiers used in the NEO-F10N module product marking.

Identifier	Format	Example
Product name	PPP-TGGV	NEO-F10N

Identifier	Format	Example
Ordering code	PPP-TGGV-NNQ	NEO-F10N-00B
Type number	PPP-TGGV-NNQ-XX	NEO-F10N-00B-00

Table 22: Product identifiers

9.3 Ordering codes

Ordering code	Product	Remark
NEO-F10N-00B	u-blox F10 multi-band GNSS receiver module, 24 pin LCC, professional grade	
NEO-F10N-00B-20	u-blox F10 multi-band GNSS receiver module, 24 pin LCC, professional grade	Carrier phase raw data

Table 23: Product ordering codes

u-blox provides information on product changes affecting the form factor, size or function of the product. For the Product change notifications (PCNs), see our website at: <https://www.u-blox.com/en/product-resources>.

Related documents

- [1] NEO-F10N Integration manual, [UBXDOC-963802114-12193](#)
- [2] u-blox F10 SPG 6.00 Interface description, [UBX-23002975](#)
- [3] u-blox F10 SPG 6.00 Release note, [UBXDOC-963802114-12318](#)
- [4] Radio Resource LCS Protocol (RRLP), (3GPP TS 44.031 version 11.0.0 Release 11)
- [5] Product packaging reference guide, [UBX-14001652](#)
- [6] Joint IPC/JEDEC standard, www.jedec.org



For regular updates to u-blox documentation and to receive product change notifications please register on our homepage <https://www.u-blox.com>.

Revision history

Revision	Date	Comments
R01	27-Jun-2023	Initial release
R02	01-Nov-2023	Engineering sample Updated: <ul style="list-style-type: none"> • KPIs in section Performance • Supported signals in Assisted GNSS services in section Supported GNSS constellations • Description of Reserved pins in section Pin definition • Pin state of SAFEBOOT_N and TIMPULSE in section Pin state • Typical and backup currents in section Indicative power requirements
R03	22-Dec-2023	Initial production Added: <ul style="list-style-type: none"> • Approvals section Updated: <ul style="list-style-type: none"> • Overview section with information related to GPS L5 • Pin state of SAFEBOOT_N and TIMPULSE in section Pin state • Operating conditions section with input impedance at RF_IN
R04	04-Apr-2025	Mass production Added: <ul style="list-style-type: none"> • Broadcast navigation data and satellite signal measurements • Qualifications and approvals • Packaging Updated sections: <ul style="list-style-type: none"> • Document information: added NEO-F10N-00B-20 • Pin state: added LNA_EN pin state • Firmware features: added carrier phase output feature for NEO-F10N-00B-20 • Absolute maximum ratings: added outband and inband limits • Updated the reel type, delivery quantity and tape dimensions in sections Reels and Tapes • Ordering codes: added NEO-F10N-00B-20 • Related documents: added Radio Resource LCS Protocol (RRLP) Change in document structure <ul style="list-style-type: none"> • Moisture sensitivity level (MSL) included in chapter Qualifications and approvals
R05	09-Oct-2025	Mass production Updated sections: <ul style="list-style-type: none"> • Updated module weight in table Mechanical specifications • Updated section Product marking

Contact

u-blox AG

Address: Zürcherstrasse 68
8800 Thalwil
Switzerland

For further support and contact information, visit us at www.u-blox.com/support.

Looking for pricing, stock, or lifecycle information?

Click below to explore more details on WIN SOURCE:

 [View NINA-B112-03B on WIN SOURCE](#)

 [U-blox Information](#)

Optimize Your Supply Chain with WIN SOURCE Solutions

-  Global Sourcing Solution
-  Obsolete Management
-  Cost Control Management
-  Shortage Management
-  Alternative Solution
-  Excess Inventory Management