



**THE DATASHEET OF  
NTCGS163JF103FT8**



# RC210xxB

VersaClock 7 Programmable Clock Generator Family

## Description

The RC210xxB devices are Renesas' seventh-generation high-performance programmable clock generators for compute, data-communications, and industrial applications.

## Applications

- High-performance computing
- Data center accelerators
- Enterprise storage
- Switches and routers
- Industrial

## Features

- 169fs RMS phase jitter at 156.25MHz (typ.)
- PCIe® Gen7 Common Clock jitter: 8fs RMS (typ.)
- PCIe SRIS and SRNS support
- 1kHz to 200MHz LVCMOS outputs

- 1kHz to 650MHz LVDS/LP-HCSL outputs
- LP-HCSL integrates 100Ω or 85Ω terminations
- Simple AC-coupling to LVPECL and CML
- Programmable General Purpose Inputs (GPI × 4) and General Purpose Input/Outputs (GPIO × 5)
- 400kHz I<sup>2</sup>C / SMBus or 20MHz SPI support
- Configuration via factory-programmed One-Time Programmable (OTP) memory, serial interface or external I<sup>2</sup>C EEPROM
- OTP holds up to four complete or 27 partial configurations
- 1.8V, 2.5V, 3.3V, -40° to +85°C operation
- RC21012B – 12 output pairs
  - 6 × 6 mm 48-QFN, integrated crystal option
- RC21008B – 8 output pairs
  - 5 × 5 mm 40-QFN, integrated crystal option
- RC21005B – 5 output pairs
  - 4 x 4 mm 32-QFN with integrated crystal

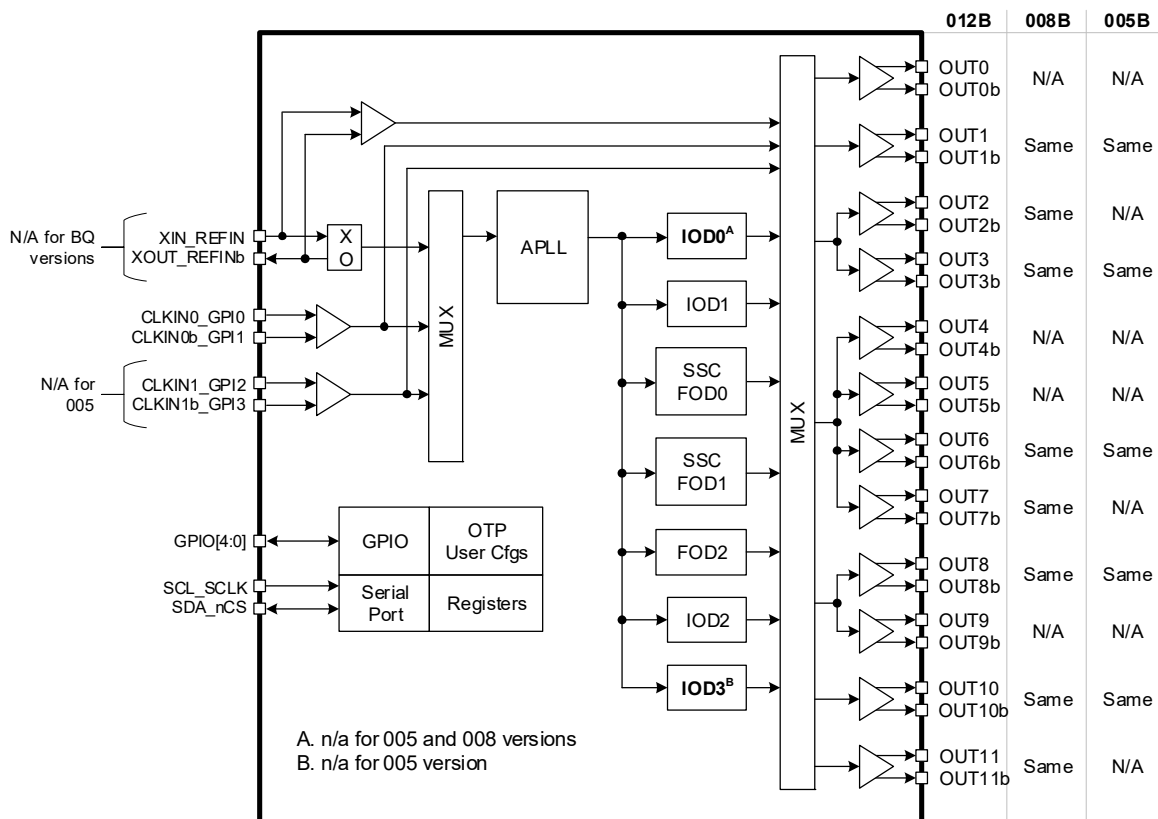

Figure 1. RC210xxB Block Diagram

## Contents

<b>1. Pin Information</b>	<b>7</b>
1.1 Pin Assignments – RCxxx12B (Top View)	7
1.2 Pin Descriptions – RCxxx12B	7
1.3 Pin Assignments – RCxxx12BQ (Top View)	9
1.4 Pin Descriptions – RCxxx12BQ	9
1.5 Pin Assignments – RCxxx08B (Top View)	11
1.6 Pin Descriptions – RCxxx08B	11
1.7 Pin Assignments – RCxxx08BQ (Top View)	13
1.8 Pin Descriptions – RCxxx08BQ	13
1.9 Pin Assignments – RCxxx05BQ (Top View)	15
1.10 Pin Descriptions – RCxxx05BQ	15
1.11 Pin Characteristics	16
<b>2. Specifications</b>	<b>18</b>
2.1 Absolute Maximum Ratings	18
2.2 Recommended Operating Conditions	18
2.3 Electrical Characteristics	19
<b>3. Functional Description</b>	<b>38</b>
3.1 Power-Up, Configuration, and Serial Interfaces	38
3.2 Input Clocks	38
3.2.1 Crystal/Reference Input	38
3.2.2 Clock Inputs	38
3.3 Clock Input Monitor	38
3.4 APLL	39
3.4.1 APLL Lock Detector	39
3.5 Output Dividers	39
3.5.1 Integer Output Dividers	39
3.5.2 Fractional Output Dividers	39
3.6 Clock Outputs	39
3.6.1 Output Types	39
3.6.2 Output Banks	40
<b>4. Application Information</b>	<b>41</b>
4.1 Recommendations for Unused Pins	41
4.1.1 XIN_REFIN/XOUT_REFINB	41
4.1.2 CLKIN/CLKINb [1:0] Inputs	41
4.1.3 GPIO/GPI Pins	41
4.1.4 LVCMOS Outputs	41
4.1.5 Differential Outputs	41
4.2 CLKIN/CLKINb Clock Inputs Interface	41
4.3 Overdriving the XTAL Interface	42
4.3.1 XTAL Interface Set to Input Buffer Mode	42
4.3.2 XTAL Interface in XO Mode, Input Buffer Mode Not Selected	42
4.4 Differential Output Terminations	44
4.4.1 Direct-Coupled LP-HCSL Termination	44
4.4.2 Direct-Coupled LVDS Termination	44
4.4.3 AC-Coupled Differential Terminations for Other Protocols	44
4.5 Crystal Recommendations	45
4.5.1 Choosing Crystals	45
4.5.2 Tuning the Crystal Load Capacitor	45
4.6 External I2C Serial EEPROM Recommendations	46
4.7 Power Considerations	46
4.7.1 Power Sequencing Considerations	46

<b>5. Thermal Information</b> .....	<b>48</b>
5.1 VFQFPN ePad Thermal Release Path .....	48
5.2 Thermal Characteristics .....	48
<b>6. Package Outline Drawings</b> .....	<b>51</b>
<b>7. Marking Diagrams</b> .....	<b>51</b>
<b>8. Ordering Information</b> .....	<b>53</b>
<b>9. Revision History</b> .....	<b>54</b>

## Figures

Figure 1. RC210xxB Block Diagram .....	1
Figure 2. I2C/SMBus Target Timing Diagram .....	35
Figure 3. SPI Bus Timing .....	36
Figure 4. Programmable Input Buffer Logical Diagram .....	41
Figure 5. Input Buffer Behavior by Protocol .....	42
Figure 6. 1.2V LVCMOS Driver to XTAL Input Interface .....	43
Figure 7. LVCMOS Driver to XTAL Input Interface .....	43
Figure 8. LVPECL Driver to XTAL Input Interface .....	43
Figure 9. Standard HCSL Termination .....	44
Figure 10. Standard LVDS Termination .....	44
Figure 11. AC-Coupling Termination .....	44
Figure 12. Crystal Load Capacity .....	45
Figure 13. Power Supply Sequencing Recommendations – Power-Up Using PWRGD/PWRDN# or POR# .....	47
Figure 14. P.C. Assembly for Exposed Pad Thermal Release Path – Side View .....	48
Figure 15. Pin 1 Orientation in Tape and Reel Packaging .....	52

## Tables

Table 1. RCxxx12B Pin Descriptions	7
Table 2. RCxxx12B Pin Descriptions	9
Table 3. RCxxx08B Pin Descriptions	11
Table 4. RCxxx08BQ Pin Descriptions	13
Table 5. RCxxx05BQ Pin Descriptions	15
Table 6. Pin Characteristics	16
Table 7. Absolute Maximum Ratings	18
Table 8. Recommended Operating Conditions	18
Table 9. PCIe Refclk Phase Jitter, Clock Generator Mode, VDDO = 1.8V/2.5V/3.3V	19
Table 10. PCIe Refclk Additive Phase Jitter, Fanout Mode, VDDO = 1.8V/2.5V/3.3V	20
Table 11. Phase Jitter and Phase Noise – 1.8V VDDO	20
Table 12. Phase Jitter and Phase Noise – 2.5V VDDO	21
Table 13. Phase Jitter and Phase Noise – 3.3V VDDO	21
Table 14. Clock Input Frequencies	21
Table 15. External Crystal Characteristics	22
Table 16. Internal Crystal Characteristics (Q Versions Only)	22
Table 17. Output Enable/Disable Timing	22
Table 18. Output Frequencies and Startup Times	23
Table 19. Output-to-Output, Input-to-Output Skew – LP-HCSL Outputs 1.8V/2.5V/3.3V VDDO	23
Table 20. Output-to-Output, Input-to-Output Skew – LVDS Outputs 1.8V/2.5V/3.3V VDDO	23
Table 21. Output-to-Output, Input-to-Output Skew – LVCMOS Outputs 1.8V/2.5V/3.3V VDDO	24
Table 22. Static Phase Offset - Zero Delay Buffer Mode	24
Table 23. LVCMOS AC/DC Output Characteristics – 1.8V VDDO	24
Table 24. LVCMOS AC/DC Output Characteristics – 2.5V VDDO	25
Table 25. LVCMOS AC/DC Output Characteristics – 3.3V VDDO	25
Table 26. LVDS AC/DC Output Characteristics – 1.8V VDDO	25
Table 27. LVDS AC/DC Output Characteristics – 2.5V/3.3V VDDO	26
Table 28. LP-HCSL AC/DC Characteristics, Non-PCIe Frequencies – 1.8V VDDO	27
Table 29. LP-HCSL AC/DC Characteristics, Non-PCIe Frequencies – 2.5V/3.3V VDDO	28
Table 30. LP-HCSL AC/DC Characteristics, 100MHz PCIe – 1.8V VDDO	29
Table 31. LP-HCSL AC/DC Characteristics, 100MHz PCIe – 2.5V/3.3V VDDO	30
Table 32. 100MHz PCIe Output Clock Accuracy and SSC	31
Table 33. Spread-Spectrum Programmability	32
Table 34. CLKIN Differential Electrical Characteristics	32
Table 35. GPI/GPIO Electrical Characteristics – 1.8V VDDD, VDDR, or VDDX	32
Table 36. GPI/GPIO Electrical Characteristics – 2.5V VDDD, VDDR, or VDDX	33
Table 37. GPI/GPIO Electrical Characteristics – 3.3V VDDD, VDDR, or VDDX	33
Table 38. CMOS GPI/GPIO Common Electrical Characteristics	33
Table 39. Power Supply Current	34
Table 40. I2C/SMBus Bus DC Electrical Characteristics	35
Table 41. I2C/SMBus Bus AC Electrical Characteristics	35
Table 42. SPI Target Interface Electrical Characteristics	37
Table 43. Power Supply Noise Rejection	37
Table 44. Output Bank Source Mapping	40
Table 45. VDD Pin Assignments for Outputs, Integer Output Dividers, and Fractional Output Dividers	40
Table 46. Input Buffer Programming Options for Specific Signaling Protocols	42
Table 47. XTAL[5:0] Tuning Capacitor	45
Table 48. Thermal Characteristics (48-pin with External Crystal)	48
Table 49. Thermal Characteristics (40-pin with External Crystal)	49
Table 50. Thermal Characteristics (48-pin with Internal Crystal)	49
Table 51. Thermal Characteristics (40-pin with Internal Crystal)	49

Table 52. Thermal Characteristics (32-pin with Internal Crystal) ..... 50  
Table 53. Ordering Information ..... 53

# 1. Pin Information

## 1.1 Pin Assignments – RCxxx12B (Top View)

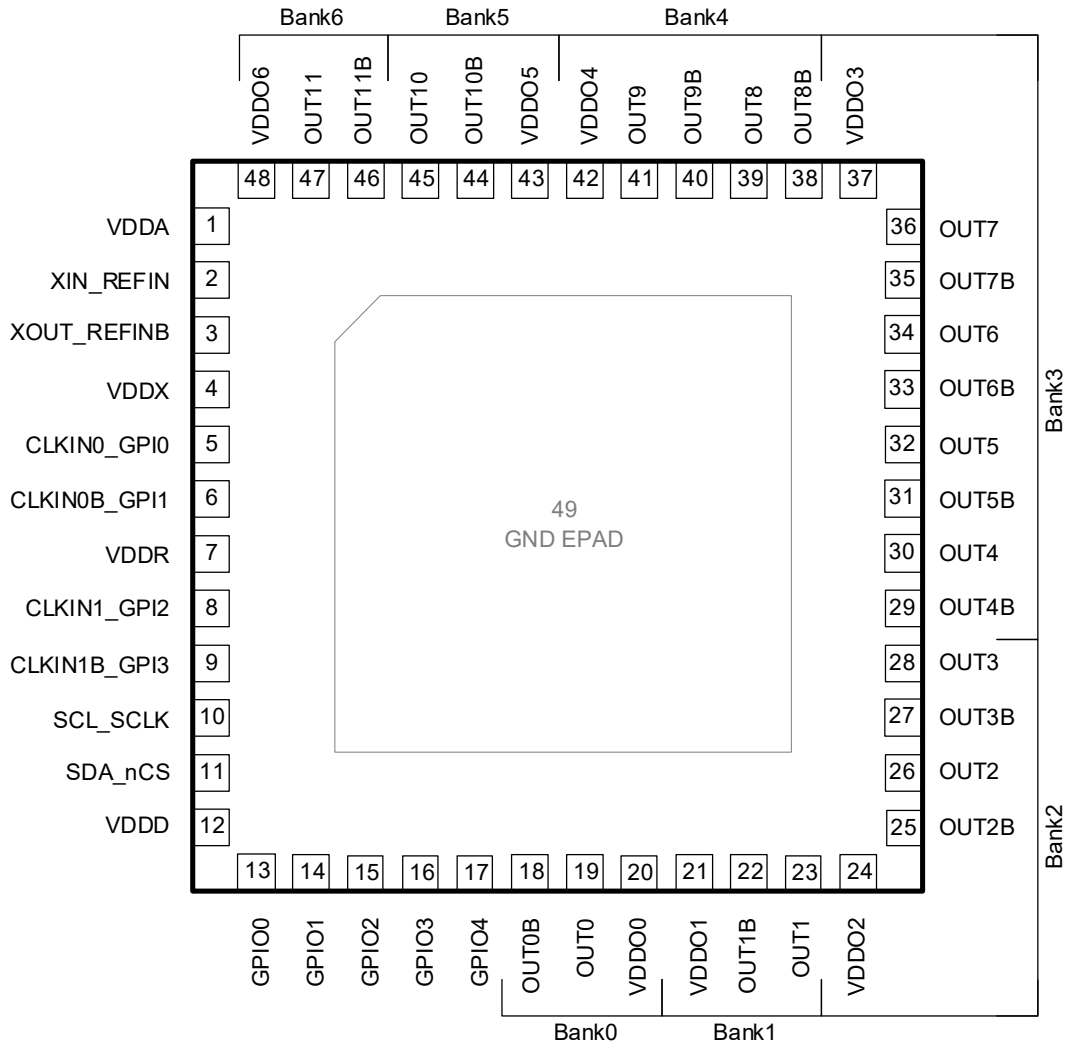

## 1.2 Pin Descriptions – RCxxx12B

Table 1. RCxxx12B Pin Descriptions

Number	Name	Type	Description
1	VDDA	Power	Analog power supply. See Table 8 for supported voltages.
2	XIN_REFIN	I	Crystal Input or differential reference clock positive input / CMOS single-ended reference clock input.
3	XOUT_REFINb	I/O	Crystal Output or differential reference clock negative input. This pin should be connected to a crystal. If an oscillator is connected to XIN_REFIN, then this pin must be left unconnected.
4	VDDX	Power	Crystal oscillator power supply. See Table 8 for supported voltages.
5	CLKIN0_GPI0	I	Differential clock positive input / CMOS single-ended reference clock input or general purpose input pin GPIO.
6	CLKIN0b_GPI1	I	Differential clock negative input / CMOS single-ended reference clock input or general purpose input pin GPI1.
7	VDDR	Power	CLKIN (receiver) power supply. See Table 8 for supported voltages.
8	CLKIN1_GPI2	I	Differential clock positive input / CMOS single-ended reference clock input or general purpose input pin GPI2.

Table 1. RCxxx12B Pin Descriptions (Cont.)

Number	Name	Type	Description
9	CLKIN1b_GPI3	I	Differential clock negative input / CMOS single-ended reference clock input or general purpose input pin GPI3.
10	SCL_SCLK	I	I2C Mode: I <sup>2</sup> C interface bi-directional clock. SPI Mode: Serial Clock This pin is 3.3V tolerant.
11	SDA_nCS	I	I2C Mode: I <sup>2</sup> C interface bi-directional data in open-drain mode. SPI Mode: Chip Select (active low) This pin is 3.3V tolerant.
12	VDDD	Power	Digital core and GPIO power supply. See <a href="#">Table 8</a> for supported voltages. When programming the OTP, this supply must be 2.5V or 3.3V.
13	GPIO0	I/O	General purpose input/output. 3-level logic input during power-up and CMOS level logic after unless set to 3-level.
14	GPIO1	I/O	General purpose input/output. 3-level logic input during power-up and CMOS level logic after unless set to 3-level.
15	GPIO2	I/O	General purpose input/output. 3-level logic input during power-up and CMOS level logic after unless set to 3-level.
16	GPIO3	I/O	General purpose input/output.
17	GPIO4	I/O	General purpose input/output.
18	OUT0b	O	Output Clock 0 negative.
19	OUT0	O	Output Clock 0 positive.
20	VDDO0	Power	Power supply for output bank 0 and IOD 0. See <a href="#">Table 8</a> for supported voltages.
21	VDDO1	Power	Power supply for output bank 1 and IOD 1. See <a href="#">Table 8</a> for supported voltages.
22	OUT1b	O	Output Clock 1 negative.
23	OUT1	O	Output Clock 1 positive.
24	VDDO2	Power	Power supply for output bank 2 and FOD 0. See <a href="#">Table 8</a> for supported voltages.
25	OUT2b	O	Output Clock 2 negative.
26	OUT2	O	Output Clock 2 positive.
27	OUT3b	O	Output Clock 3 negative.
28	OUT3	O	Output Clock 3 positive.
29	OUT4b	O	Output Clock 4 negative.
30	OUT4	O	Output Clock 4 positive.
31	OUT5b	O	Output Clock 5 negative.
32	OUT5	O	Output Clock 5 positive.
33	OUT6b	O	Output Clock 6 negative.
34	OUT6	O	Output Clock 6 positive.
35	OUT7b	O	Output Clock 7 negative.
36	OUT7	O	Output Clock 7 positive.
37	VDDO3	Power	Power supply for output bank 3 and FOD 1. See <a href="#">Table 8</a> for supported voltages.
38	OUT8b	O	Output Clock 8 negative.
39	OUT8	O	Output Clock 8 positive.
40	OUT9b	O	Output Clock 9 negative.
41	OUT9	O	Output Clock 9 positive.
42	VDDO4	Power	Power supply for output bank 4 and FOD 2. See <a href="#">Table 8</a> for supported voltages.
43	VDDO5	Power	Power supply for output bank 5 and IOD 2. See <a href="#">Table 8</a> for supported voltages.
44	OUT10b	O	Output Clock 10 negative.
45	OUT10	O	Output Clock 10 positive.
46	OUT11b	O	Output Clock 11 negative.
47	OUT11	O	Output Clock 11 positive.

Table 1. RCxxx12B Pin Descriptions (Cont.)

Number	Name	Type	Description
48	VDDO6	Power	Supply voltage for output bank 6 and IOD 3. See Table 8 for supported voltages.
EPAD	GND	Power	Ground. ePad must be connected to ground before any VDD is applied.

### 1.3 Pin Assignments – RCxxx12BQ (Top View)

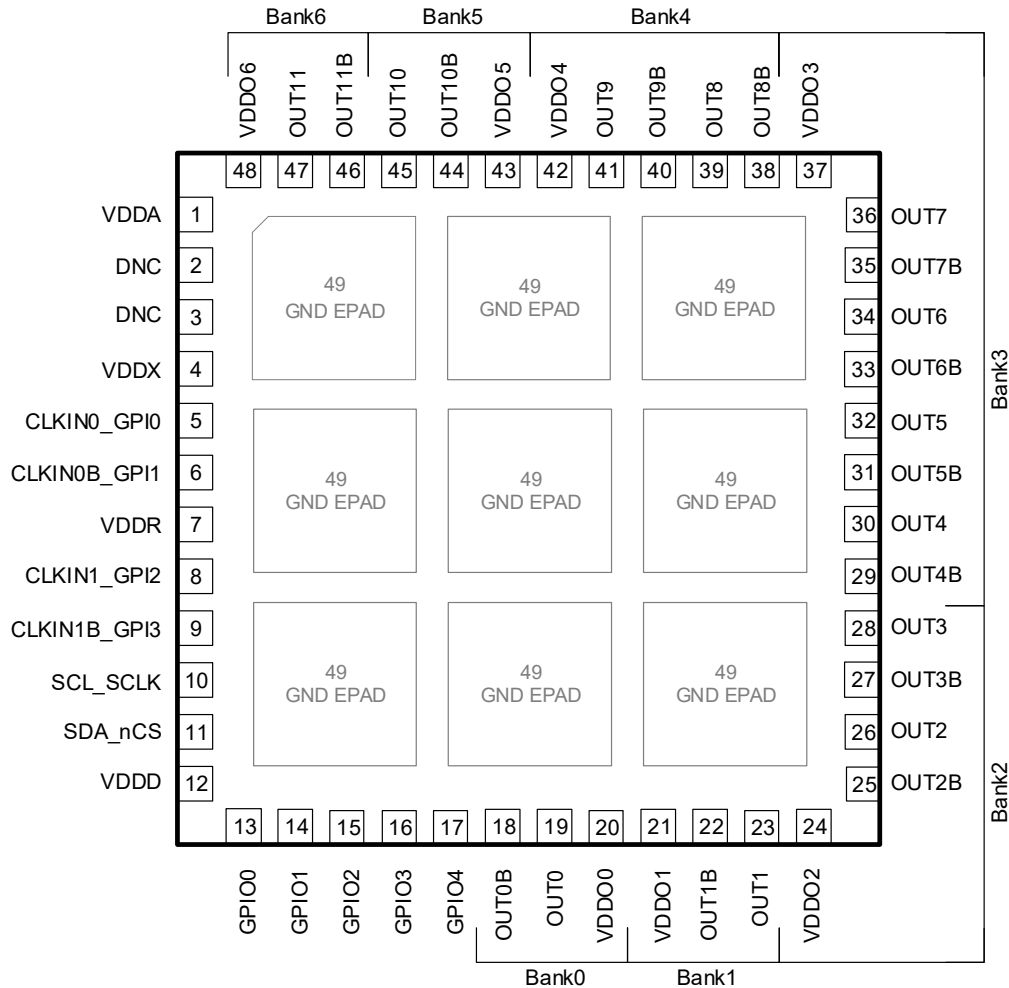

### 1.4 Pin Descriptions – RCxxx12BQ

Table 2. RCxxx12B Pin Descriptions

Number	Name	Type	Description
1	VDDA	Power	Analog power supply. See Table 8 for supported voltages.
2	DNC	N/A	Do not connect. This pin should have no stubs.
3	DNC	N/A	Do not connect. This pin should have no stubs.
4	VDDX	Power	Crystal oscillator power supply. See Table 8 for supported voltages.
5	CLKIN0_GPIO	I	Differential clock positive input / CMOS single-ended reference clock input or general purpose input pin GPIO.
6	CLKIN0b_GPIO1	I	Differential clock negative input / CMOS single-ended reference clock input or general purpose input pin GPIO1.
7	VDDR	Power	CLKIN (receiver) power supply. See Table 8 for supported voltages.
8	CLKIN1_GPIO2	I	Differential clock positive input / CMOS single-ended reference clock input or general purpose input pin GPIO2.

Table 2. RCxxx12B Pin Descriptions (Cont.)

Number	Name	Type	Description
9	CLKIN1b_GPI3	I	Differential clock negative input / CMOS single-ended reference clock input or general purpose input pin GPI3.
10	SCL_SCLK	I	I2C Mode: I <sup>2</sup> C interface bi-directional clock. SPI Mode: Serial Clock This pin is 3.3V tolerant.
11	SDA_nCS	I	I2C Mode: I <sup>2</sup> C interface bi-directional data in open-drain mode. SPI Mode: Chip Select (active low) This pin is 3.3V tolerant.
12	VDDD	Power	Digital core and GPIO power supply. See <a href="#">Table 8</a> for supported voltages. When programming the OTP, this supply must be 2.5V or 3.3V.
13	GPIO0	I/O	General purpose input/output. 3-level logic input during power-up and CMOS level logic after unless set to 3-level.
14	GPIO1	I/O	General purpose input/output. 3-level logic input during power-up and CMOS level logic after unless set to 3-level.
15	GPIO2	I/O	General purpose input/output. 3-level logic input during power-up and CMOS level logic after unless set to 3-level.
16	GPIO3	I/O	General purpose input/output.
17	GPIO4	I/O	General purpose input/output.
18	OUT0b	O	Output Clock 0 negative.
19	OUT0	O	Output Clock 0 positive.
20	VDDO0	Power	Power supply for output bank 0 and IOD 0. See <a href="#">Table 8</a> for supported voltages.
21	VDDO1	Power	Power supply for output bank 1 and IOD 1. See <a href="#">Table 8</a> for supported voltages.
22	OUT1b	O	Output Clock 1 negative.
23	OUT1	O	Output Clock 1 positive.
24	VDDO2	Power	Power supply for output bank 2 and FOD 0. See <a href="#">Table 8</a> for supported voltages.
25	OUT2b	O	Output Clock 2 negative.
26	OUT2	O	Output Clock 2 positive.
27	OUT3b	O	Output Clock 3 negative.
28	OUT3	O	Output Clock 3 positive.
29	OUT4b	O	Output Clock 4 negative.
30	OUT4	O	Output Clock 4 positive.
31	OUT5b	O	Output Clock 5 negative.
32	OUT5	O	Output Clock 5 positive.
33	OUT6b	O	Output Clock 6 negative.
34	OUT6	O	Output Clock 6 positive.
35	OUT7b	O	Output Clock 7 negative.
36	OUT7	O	Output Clock 7 positive.
37	VDDO3	Power	Power supply for output bank 3 and FOD 1. See <a href="#">Table 8</a> for supported voltages.
38	OUT8b	O	Output Clock 8 negative.
39	OUT8	O	Output Clock 8 positive.
40	OUT9b	O	Output Clock 9 negative.
41	OUT9	O	Output Clock 9 positive.
42	VDDO4	Power	Power supply for output bank 4 and FOD 2. See <a href="#">Table 8</a> for supported voltages.
43	VDDO5	Power	Power supply for output bank 5 and IOD 2. See <a href="#">Table 8</a> for supported voltages.
44	OUT10b	O	Output Clock 10 negative.
45	OUT10	O	Output Clock 10 positive.
46	OUT11b	O	Output Clock 11 negative.
47	OUT11	O	Output Clock 11 positive.

Table 2. RCxxx12B Pin Descriptions (Cont.)

Number	Name	Type	Description
48	VDDO6	Power	Supply voltage for output bank 6 and IOD 3. See Table 8 for supported voltages.
EPAD	GND	Power	Ground. ePad must be connected to ground before any VDD is applied.

### 1.5 Pin Assignments – RCxxx08B (Top View)

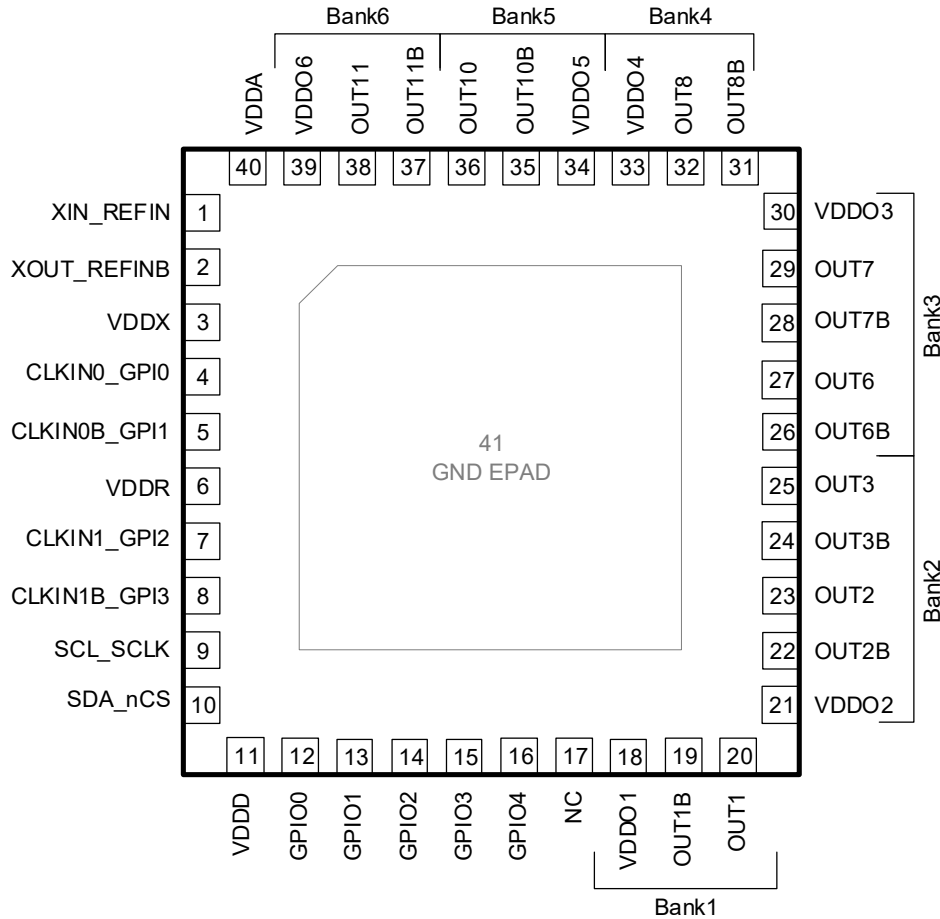

### 1.6 Pin Descriptions – RCxxx08B

Table 3. RCxxx08B Pin Descriptions

Number	Name	Type	Description
1	XIN_REFIN	I	Crystal Input or differential reference clock positive input / CMOS single-ended reference clock input.
2	XOUT_REFINb	I/O	Crystal Output or differential reference clock negative input. This pin should be connected to a crystal. If an oscillator is connected to XIN_REFIN, then this pin must be left unconnected.
3	VDDX	Power	Crystal oscillator power supply. See Table 8 for supported voltages.
4	CLKIN0_GPI0	I	differential clock positive input / CMOS single-ended reference clock input or general purpose input pin GPI0.
5	CLKIN0b_GPI1	I	differential clock negative input / CMOS single-ended reference clock input or general purpose input pin GPI1.
6	VDDR	Power	CLKIN (receiver) power supply. See Table 8 for supported voltages.
7	CLKIN1_GPI2	I	Differential clock positive input / CMOS single-ended reference clock input or general purpose input pin GPI2.

Table 3. RCxxx08B Pin Descriptions (Cont.)

Number	Name	Type	Description
8	CLKIN1b_GPI3	I	Differential clock negative input / CMOS single-ended reference clock input or general purpose input pin GPI3.
9	SCL_SCLK	I	I2C Mode: I <sup>2</sup> C interface bi-directional clock. SPI Mode: Serial Clock This pin is 3.3V tolerant.
10	SDA_nCS	I/O	I2C Mode: I <sup>2</sup> C interface bi-directional data in open-drain mode. SPI Mode: Chip Select (active low) This pin is 3.3V tolerant.
11	VDDD	Power	Digital core and GPIO power supply. See <a href="#">Table 8</a> for supported voltages. When programming the OTP, this supply must be 2.5V or 3.3V.
12	GPIO0	I/O	General purpose input/output. 3-level logic input during power-up and CMOS level logic after unless set to 3-level.
13	GPIO1	I/O	General purpose input/output. 3-level logic input during power-up and CMOS level logic after unless set to 3-level.
14	GPIO2	I/O	General purpose input/output. 3-level logic input during power-up and CMOS level logic after unless set to 3-level.
15	GPIO3	I/O	General purpose input/output.
16	GPIO4	I/O	General purpose input/output.
17	NC	I	Not connected.
18	VDDO1	Power	Power supply for output bank 1 and IOD 1. See <a href="#">Table 8</a> for supported voltages.
19	OUT1b	O	Output Clock 1 negative.
20	OUT1	O	Output Clock 1 positive
21	VDDO2	Power	Power supply for output bank 2 and FOD 0. See <a href="#">Table 8</a> for supported voltages.
22	OUT2b	O	Output Clock 2 negative.
23	OUT2	O	Output Clock 2 positive.
24	OUT3b	O	Output Clock 3 negative.
25	OUT3	O	Output Clock 3 positive.
26	OUT6b	O	Output Clock 6 negative.
27	OUT6	O	Output Clock 6 positive.
28	OUT7b	O	Output Clock 7 negative.
29	OUT7	O	Output Clock 7 positive.
30	VDDO3	Power	Power supply for output bank 3 and FOD 1. See <a href="#">Table 8</a> for supported voltages.
31	OUT8b	O	Output Clock 8 negative.
32	OUT8	O	Output Clock 8 positive.
33	VDDO4	Power	Power supply for output bank 4 and FOD 2. See <a href="#">Table 8</a> for supported voltages.
34	VDDO5	Power	Power supply for output bank 5 and IOD 2. See <a href="#">Table 8</a> for supported voltages.
35	OUT10b	O	Output Clock 10 negative.
36	OUT10	O	Output Clock 10 positive.
37	OUT11b	O	Output Clock 11 negative.
38	OUT11	O	Output Clock 11 positive.
39	VDDO6	Power	Supply voltage for output bank 6 and IOD 3. See <a href="#">Table 8</a> for supported voltages.
40	VDDA	Power	Analog power supply. See <a href="#">Table 8</a> for supported voltages.
EPAD	GND	Power	Ground. ePad must be connected to ground before any VDD is applied.

### 1.7 Pin Assignments – RCxxx08BQ (Top View)

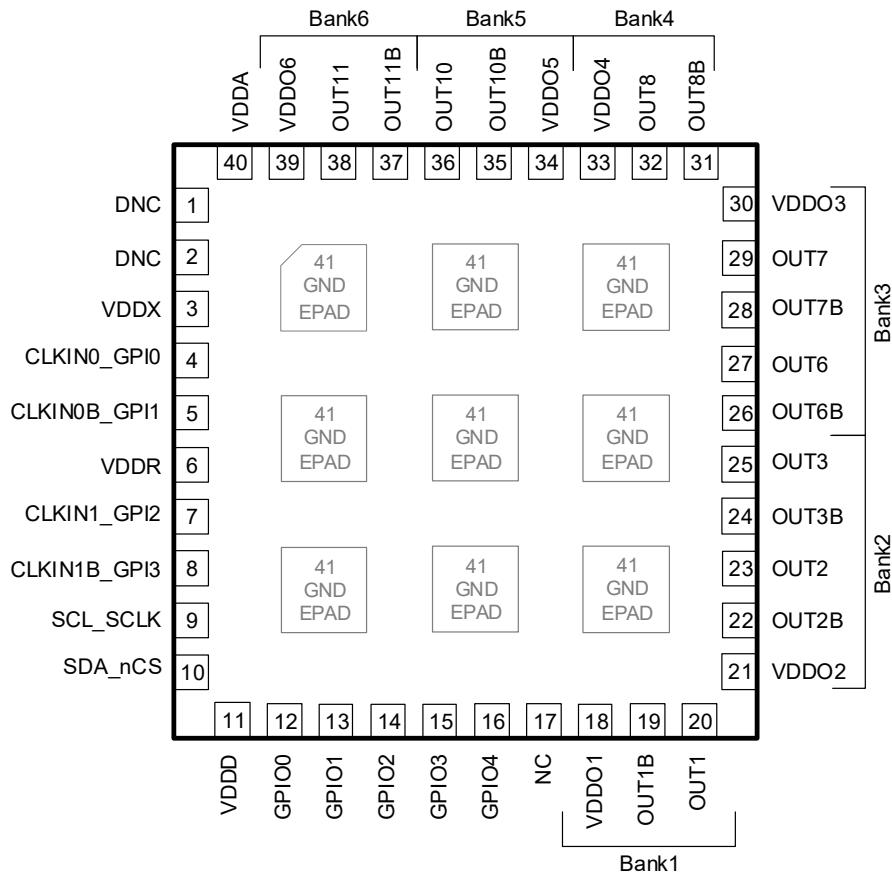

### 1.8 Pin Descriptions – RCxxx08BQ

Table 4. RCxxx08BQ Pin Descriptions

Number	Name	Type	Description
1	DNC	N/A	Do not connect. This pin should have no stubs.
2	DNC	N/A	Do not connect. This pin should have no stubs.
3	VDDX	Power	Crystal oscillator power supply. See Table 8 for supported voltages.
4	CLKIN0_GPI0	I	Differential clock positive input / CMOS single-ended reference clock input or general purpose input pin GPIO0.
5	CLKIN0b_GPI1	I	Differential clock negative input / CMOS single-ended reference clock input or general purpose input pin GPIO1.
6	VDDR	Power	CLKIN (receiver) power supply. See Table 8 for supported voltages.
7	CLKIN1_GPI2	I	Differential clock positive input / CMOS single-ended reference clock input or general purpose input pin GPIO2.
8	CLKIN1b_GPI3	I	Differential clock negative input / CMOS single-ended reference clock input or general purpose input pin GPIO3.
9	SCL_SCLK	I	I2C Mode: I <sup>2</sup> C interface bi-directional clock. SPI Mode: Serial Clock This pin is 3.3V tolerant.
10	SDA_nCS	I/O	I2C Mode: I <sup>2</sup> C interface bi-directional data in open-drain mode. SPI Mode: Chip Select (active low) This pin is 3.3V tolerant.
11	VDDD	Power	Digital core and GPIO power supply. See Table 8 for supported voltages. When programming the OTP, this supply must be 2.5V or 3.3V.

Table 4. RCxxx08BQ Pin Descriptions (Cont.)

Number	Name	Type	Description
12	GPIO0	I/O	General purpose input/output. 3-level logic input during power-up and CMOS level logic after unless set to 3-level.
13	GPIO1	I/O	General purpose input/output. 3-level logic input during power-up and CMOS level logic after unless set to 3-level.
14	GPIO2	I/O	General purpose input/output. 3-level logic input during power-up and CMOS level logic after unless set to 3-level.
15	GPIO3	I/O	General purpose input/output.
16	GPIO4	I/O	General purpose input/output.
17	NC	I	Not connected.
18	VDDO1	Power	Power supply for output bank 1 and IOD 1. See <a href="#">Table 8</a> for supported voltages.
19	OUT1b	O	Output Clock 1 negative.
20	OUT1	O	Output Clock 1 positive
21	VDDO2	Power	Power supply for output bank 2 and FOD 0. See <a href="#">Table 8</a> for supported voltages.
22	OUT2b	O	Output Clock 2 negative.
23	OUT2	O	Output Clock 2 positive.
24	OUT3b	O	Output Clock 3 negative.
25	OUT3	O	Output Clock 3 positive.
26	OUT6b	O	Output Clock 6 negative.
27	OUT6	O	Output Clock 6 positive.
28	OUT7b	O	Output Clock 7 negative.
29	OUT7	O	Output Clock 7 positive.
30	VDDO3	Power	Power supply for output bank 3 and FOD 1. See <a href="#">Table 8</a> for supported voltages.
31	OUT8b	O	Output Clock 8 negative.
32	OUT8	O	Output Clock 8 positive.
33	VDDO4	Power	Power supply for output bank 4 and FOD 2. See <a href="#">Table 8</a> for supported voltages.
34	VDDO5	Power	Power supply for output bank 5 and IOD 2. See <a href="#">Table 8</a> for supported voltages.
35	OUT10b	O	Output Clock 10 negative.
36	OUT10	O	Output Clock 10 positive.
37	OUT11b	O	Output Clock 11 negative.
38	OUT11	O	Output Clock 11 positive.
39	VDDO6	Power	Supply voltage for output bank 6 and IOD 3. See <a href="#">Table 8</a> for supported voltages.
40	VDDA	Power	Analog power supply. See <a href="#">Table 8</a> for supported voltages.
EPAD	GND	Power	Ground. ePad must be connected to ground before any VDD is applied.

### 1.9 Pin Assignments – RCxxx05BQ (Top View)

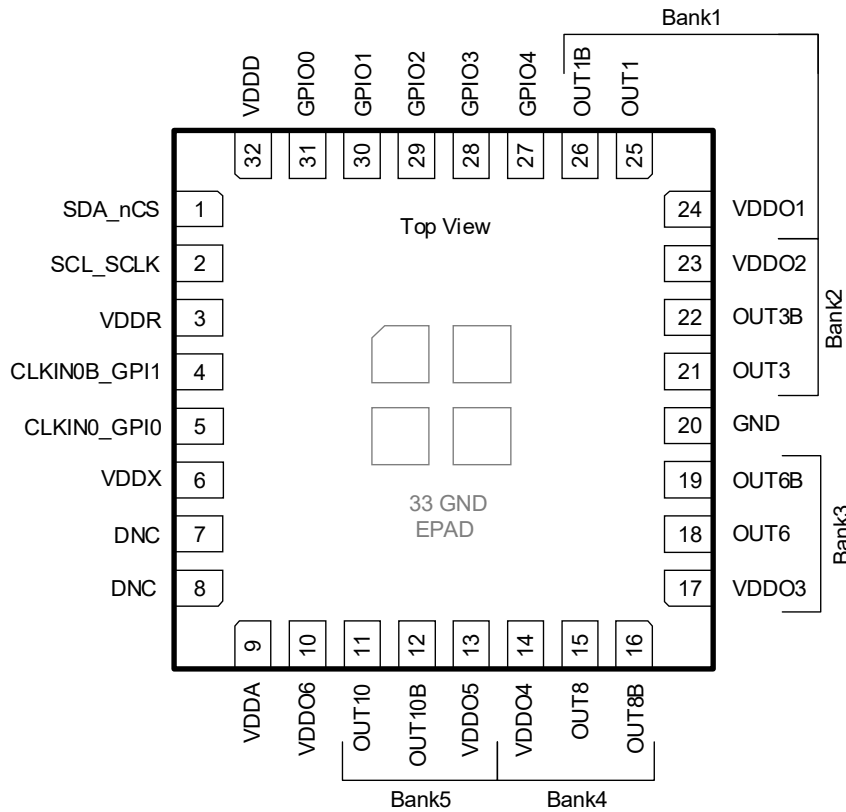

### 1.10 Pin Descriptions – RCxxx05BQ

Table 5. RCxxx05BQ Pin Descriptions

Number	Name	Type	Description
1	SDA_nCS	I/O	I2C Mode: I <sup>2</sup> C interface bi-directional data in open-drain mode. SPI Mode: Chip Select (active low) This pin is 3.3V tolerant.
2	SCL_SCLK	I	I2C Mode: I <sup>2</sup> C interface bi-directional clock. SPI Mode: Serial Clock This pin is 3.3V tolerant.
3	VDDR	Power	CLKIN (receiver) power supply. See Table 8 for supported voltages.
4	CLKIN0b_GPI1	I	Differential clock negative input / CMOS single-ended reference clock input or general purpose input pin GPI1
5	CLKIN0_GPI0	I	Differential clock positive input / CMOS single-ended reference clock input or general purpose input pin GPI0
6	VDDX	Power	Crystal oscillator power supply. See Table 8 for supported voltages.
7	DNC	NA	Do not connect. This pin should have no stubs.
8	DNC	NA	Do not connect. This pin should have no stubs.
9	VDDA	Power	Analog power supply. See Table 8 for supported voltages.
10	VDDO6	Power	Supply voltage for output bank 6 and IOD 3. See Table 8 for supported voltages.
11	OUT10	O	Output Clock 10 positive.
12	OUT10b	O	Output Clock 10 negative.
13	VDDO5	Power	Power supply for output bank 5 and IOD 2. See Table 8 for supported voltages.

Table 5. RCxx05BQ Pin Descriptions (Cont.)

Number	Name	Type	Description
14	VDDO4	Power	Power supply for output bank 4 and FOD 2. See Table 8 for supported voltages.
15	OUT8	O	Output Clock 8 positive.
16	OUT8b	O	Output Clock 8 negative.
17	VDDO3	Power	Power supply for output bank 3 and FOD 1. See Table 8 for supported voltages.
18	OUT6	O	Output Clock 6 positive.
19	OUT6b	O	Output Clock 6 negative.
20	GND	Power	Ground
21	OUT3	O	Output Clock 3 positive.
22	OUT3b	O	Output Clock 3 negative.
23	VDDO2	Power	Power supply for output bank 2 and FOD 0. See Table 8 for supported voltages.
24	VDDO1	Power	Power supply for output bank 1 and IOD 1. See Table 8 for supported voltages.
25	OUT1	O	Output Clock 1 positive
26	OUT1b	O	Output Clock 1 negative.
27	GPIO4	I/O	General purpose input/output
28	GPIO3	I/O	General purpose input/output
29	GPIO2	I/O	General purpose input/output 3-level logic input during power-up and CMOS level logic after unless set to 3-level.
30	GPIO1	I/O	General purpose input/output 3-level logic input during power-up and CMOS level logic after unless set to 3-level.
31	GPIO0	I/O	General purpose input/output 3-level logic input during power-up and CMOS level logic after unless set to 3-level.
32	VDDD	Power	Digital core and GPIO power supply. See Table 8 for supported voltages. When programming the OTP, this supply must be 2.5V or 3.3V.
EPAD	GND	Power	Ground. ePad must be connected to ground before any VDD is applied.

## 1.11 Pin Characteristics

Table 6. Pin Characteristics

Symbol	Parameter	Test Conditions	Minimum	Typical	Maximum	Unit
$C_{IN}$	Input Capacitance	CLKIN[1:0], CLKIN[1:0]b, GPI[0:3]	-	2	-	pF
		SCL_SCLK, SDA_nCS	-	3	-	
		XIN_REFIN [1]	-	5	-	
		XOUT_REFINb [1]	-	4	-	
		GPIO[0:4]	-	5	-	
$R_{PULLUP}$	Input Pull-Up Resistor	All pins with internal pull up capability	-	52.6	-	k $\Omega$
$R_{PULLDOWN}$	Input Pull-Down Resistor	All pins with internal pull down capability	-	52.6	-	
$Z_{OUTDC}$	Single-ended LP-HCSL Output Impedance	50 $\Omega$ single-ended (100 $\Omega$ differential).	-	51	-	40 to 60 $\Omega$
		42.5 $\Omega$ single-ended (85 $\Omega$ differential).	-	44	-	34 to 51 $\Omega$
	LVCMOS Output Impedance	VDDO = 3.3V	-	17.3	-	$\Omega$
		VDDO = 2.5V.	-	19.5	-	
VDDO = 1.8V	-	17.6	-			

1. When used as clock input.



## 2. Specifications

The absolute maximum ratings are stress ratings only. Stresses greater than those listed below can cause permanent damage to the device. Functional operation of the RC210xxB at absolute maximum ratings is not implied. Exposure to absolute maximum rating conditions may affect device reliability.

### 2.1 Absolute Maximum Ratings

Table 7. Absolute Maximum Ratings

Symbol	Parameter	Conditions	Minimum	Maximum	Unit
$V_{DD}$	Supply Voltage with respect to Ground	Any VDD pin	-0.5	3.63	V
$V_{IN}$	Input Voltage [1]	XIN_REFIN, XOUT_REFINb [2]	-0.5	$V_{DD} + 0.3$	V
		CLKIN[1:0]_GPI[1:0], CLKIN[1:0]b_GPI[3:2]	-0.5	$V_{DD} + 0.3$	V
		GPIO[4:0] used as inputs	-0.5	$V_{DD} + 0.3$	V
		SCL_SCLK, SDA_nCS	-0.5	3.63	V
$I_{IN}$	Input Current	CLKIN[1:0]_GPI[1:0], CLKIN[1:0]b_GPI[3:2]	-	$\pm 50$	mA
$I_{OUT}$	Output Current - Continuous	OUT[11:0], OUT[11:0]b	-	30	mA
		GPIO[4:0] used as outputs, SDA_nCS	-	25	mA
	Output Current - Surge	OUT[11:0], OUT[11:0]b	-	60	mA
		GPIO[4:0] used as outputs, SDA_nCS	-	50	mA
$T_J$	Maximum Junction Temperature	-	-	150	$^{\circ}\text{C}$
$T_S$	Storage Temperature	Storage Temperature	-65	150	$^{\circ}\text{C}$
ESD	Human Body Model	JESD22-A114 (JS-001) Classification	-	2000	V
	Charged Device Model	JESD22-C101 Classification	-	500	V

1. VDD refers to the VDD pin that supplies the particular input. To determine to which VDD pin the specification applies, see [Table 45](#).
2. This limit only applies when XIN\_REFIN/XOUT\_REFINb are configured as an "Input Buffer" for use with an external oscillator. No limit is implied when connected directly to a crystal.

### 2.2 Recommended Operating Conditions

Table 8. Recommended Operating Conditions [1][2]

Symbol	Parameter	Conditions	Minimum	Typical	Maximum	Unit
$T_J$	Maximum Junction Temperature	-	-	-	125	$^{\circ}\text{C}$
$T_A$	Ambient Operating temperature	-	-40	-	85	$^{\circ}\text{C}$
$V_{DDx}$	Supply Voltage with respect to Ground	Any VDD pin, 1.8V supply	1.71	1.8	1.89	V
		Any VDD pin, 2.5V supply	2.375	2.5	2.625	V
		Any VDD pin, 3.3V supply	3.135	3.3	3.465	V
$t_{PU}$	Power-up time for all VDDs to reach minimum specified voltage.	Power ramps must be monotonic. For more considerations, see <a href="#">Application Information</a> .	0.2	-	5	ms

1. All electrical characteristics are specified over Recommended Operating Conditions unless noted otherwise.
2. All conditions in this table must be met to guarantee device functionality and performance.

## 2.3 Electrical Characteristics

Table 9. PCIe Refclk Phase Jitter, Clock Generator Mode, VDDO = 1.8V/2.5V/3.3V [1][2]

Symbol	Parameter	Condition	Typical	Maximum	PCIe Limit	Unit	
$t_{jph}PCleG1-CC$	PCIe Gen1 (2.5 GT/s)	Clock Generator Mode Common Clocked (CC) Architecture SSC = -0% (off)	1821	4450	86,000	fs p-p	
$t_{jph}PCleG2-CC$	PCIe Gen2 Hi Band (5.0 GT/s)		157	382	3,100		
	PCIe Gen2 Lo Band (5.0 GT/s)		60	241	3,000		
$t_{jph}PCleG3-CC$	PCIe Gen3 (8.0 GT/s)		51	120	1,000		fs RMS
$t_{jph}PCleG4-CC$	PCIe Gen4 (16.0 GT/s)		51	120	500 [3]		
$t_{jph}PCleG5-CC$	PCIe Gen5 (32.0 GT/s)		19	46	150 [4]		
$t_{jph}PCleG6-CC$	PCIe Gen6 (64.0 GT/s)		12	29	100 [5]		
$t_{jph}PCleG7-CC$	PCIe Gen7 (128.0 GT/s)	8	20	67 [6]			
$t_{jph}PCleG1-CC$	PCIe Gen1 (2.5 GT/s)	Clock Generator Mode, CC Architecture SSC = -0.5%	4190	6910	86,000	fs p-p	
$t_{jph}PCleG2-CC$	PCIe Gen2 Hi Band (5.0 GT/s)		371	590	3,100		
	PCIe Gen2 Lo Band (5.0 GT/s)		131	279	3,000		
$t_{jph}PCleG3-CC$	PCIe Gen3 (8.0 GT/s)		123	199	1,000		fs RMS
$t_{jph}PCleG4-CC$	PCIe Gen4 (16.0 GT/s) [7]		123	199	500		
$t_{jph}PCleG5-CC$	PCIe Gen5 (32.0 GT/s)		48	77	150		
$t_{jph}PCleG6-CC$	PCIe Gen6 (64.0 GT/s)		28	47	100		
$t_{jph}PCleG7-CC$	PCIe Gen7 (128.0 GT/s)	20	33	67			
$t_{jph}PCleG2-IR$	PCIe Gen2 (5.0 GT/s)	Clock Generator Mode, Independent Reference No Spread (IR-SRNS) Architecture, SSC = 0%	159	441	[8]	fs RMS	
$t_{jph}PCleG3-IR$	PCIe Gen3 (8.0 GT/s)		60	158			
$t_{jph}PCleG4-IR$	PCIe Gen4 (16.0 GT/s)		62	164			
$t_{jph}PCleG5-IR$	PCIe Gen5 (32.0 GT/s)		16	41			
$t_{jph}PCleG6-IR$	PCIe Gen6 (64.0 GT/s)		12	33			
$t_{jph}PCleG7-IR$	PCIe Gen7 (128.0 GT/s)		9	23			
$t_{jph}PCleG2-IR$	PCIe Gen2 (5.0 GT/s)	Clock Generator Mode, Independent Reference Separate Spread (IR-SRIS) Architecture, SSC = -0.5%	1322	1382	[8]	fs RMS	
$t_{jph}PCleG3-IR$	PCIe Gen3 (8.0 GT/s)		481	499			
$t_{jph}PCleG4-IR$	PCIe Gen4 (16.0 GT/s)		315	342			
$t_{jph}PCleG5-IR$	PCIe Gen5 (32.0 GT/s)	Clock Generator Mode, IR-SRIS Architecture, SSC = -0.3%	77	128	[8]	fs RMS	
$t_{jph}PCleG6-IR$	PCIe Gen6 (64.0 GT/s)		61	66			
$t_{jph}PCleG7-IR$	PCIe Gen7 (128.0 GT/s)		31	36			

- The Refclk jitter is measured after applying the filter functions found in the *PCI Express Base Specification 7.0*. For the exact measurement setup, see Test Loads. The worst case results for each data rate are summarized in this table. Equipment noise is removed from all measurements.
- Jitter measurements are made with a capture of at least 100,000 clock cycles captured by a real-time oscilloscope (RTO) with a sample rate of 20GS/s or greater. Broadband oscilloscope noise must be minimized in the measurement. The measured PP jitter is used (no extrapolation) for RTO measurements. Alternately, jitter measurements can be made with a Phase Noise Analyzer (PNA) extending (flat) and integrating and folding the frequency content up to an offset from the carrier frequency of at least 200MHz (at 300MHz absolute frequency) below the Nyquist frequency. For PNA measurements for the 2.5GT/s data rate, the RMS jitter is converted to peak-to-peak jitter using a multiplication factor of 8.83.
- Note that 0.7ps RMS is to be used in channel simulations to account for additional noise in a real system.
- Note that 0.25ps RMS is to be used in channel simulations to account for additional noise in a real system.
- Note that 0.15ps RMS is to be used in channel simulations to account for additional noise in a real system.
- Note that 0.10ps RMS is to be used in channel simulations to account for additional noise in a real system.
- SSC spurs from the fundamental and harmonics are removed up to a cutoff frequency of 2MHz taking care to minimize removal of any non-SSC content.
- The *PCI Express Base Specification 7.0* provides the filters necessary to calculate IR jitter values; it does not provide specification limits, therefore, the reference to this footnote. IR values are informative only. A common practice is to split the common clock budget in half. For 16GT/s data rates and above, the user must choose whether to use the output jitter specification, or the input jitter specification, which includes an allocation for the jitter added by the channel. Using 32GT/s, the Refclk output jitter budget is 150fs RMS. One half of the Refclk jitter budget is 106fs RMS. At the clock input, the system must deliver a Refclk with <250fs RMS phase jitter. One half of this value is 177fs RMS. If the clock is placed next to the PCIe device in an IR system, the channel is very short and the user can choose to use this more relaxed value as the jitter limit.

**Table 10. PCIe Refclk Additive Phase Jitter, Fanout Mode, VDDO = 1.8V/2.5V/3.3V [1][2]**

Symbol	Parameter	Condition	Typical	Maximum	PCIe Limit [3]	Unit	
t <sub>jph</sub> PCIeG1-CCadd	PCIe Gen1 (2.5 GT/s)	Fanout mode, CC Architecture	2008	3955	86,000	fs p-p	
t <sub>jph</sub> PCIeG2-CCadd	PCIe Gen2 Hi Band (5.0 GT/s)		199	361	3,100		
	PCIe Gen2 Lo Band (5.0 GT/s)		88	183	3,000		
t <sub>jph</sub> PCIeG3-CCadd	PCIe Gen3 (8.0 GT/s)		67	122	1,000		fs RMS
t <sub>jph</sub> PCIeG4-CCadd	PCIe Gen4 (16.0 GT/s) [4][5]		67	122	500		
t <sub>jph</sub> PCIeG5-CCadd	PCIe Gen5 (32.0 GT/s) [3][6]		27	49	150		
t <sub>jph</sub> PCIeG6-CCadd	PCIe Gen6 (64.0 GT/s) [3][7]		16	29	100		
t <sub>jph</sub> PCIeG7-CCadd	PCIe Gen7 (128.0 GT/s) [3][8]		11	20	67		
t <sub>jph</sub> PCIeG2-IRadd	PCIe Gen2 (5.0 GT/s)	Fanout mode, IR (SRIS, SRNS) Architecture	185	329	[9]	fs RMS	
t <sub>jph</sub> PCIeG3-IRadd	PCIe Gen3 (8.0 GT/s)		72	124			
t <sub>jph</sub> PCIeG4-IRadd	PCIe Gen4 (16.0 GT/s)		74	128			
t <sub>jph</sub> PCIeG5-IRadd	PCIe Gen5 (32.0 GT/s)		20	36			
t <sub>jph</sub> PCIeG6-IRadd	PCIe Gen6 (64.0 GT/s)		15	26			
t <sub>jph</sub> PCIeG7-IRadd	PCIe Gen7 (128.0 GT/s)		10	18			

- The Refclk jitter is measured after applying the filter functions found in the *PCI Express Base Specification 7.0*. For the exact measurement setup, see Test Loads. The worst case results for each data rate are summarized in this table. Equipment noise is removed from all measurements.
- Jitter measurements are made with a capture of at least 100,000 clock cycles captured by a real-time oscilloscope (RTO) with a sample rate of 20GS/s or greater. Broadband oscilloscope noise must be minimized in the measurement. The measured PP jitter is used (no extrapolation) for RTO measurements. Alternately, jitter measurements can be made with a Phase Noise Analyzer (PNA) extending (flat) and integrating and folding the frequency content up to an offset from the carrier frequency of at least 200MHz (at 300MHz absolute frequency) below the Nyquist frequency. For PNA measurements for the 2.5GT/s data rate, the RMS jitter is converted to peak-to-peak jitter using a multiplication factor of 8.83.
- The sum of the input jitter and the RC210xxB additive jitter must be less than these values. Peak to peak values are calculated with an arithmetic sum and RMS values are calculated with an RMS sum,
- SSC spurs from the fundamental and harmonics are removed up to a cutoff frequency of 2MHz taking care to minimize removal of any non-SSC content.
- Note that 0.7ps RMS is to be used in channel simulations to account for additional noise in a real system.
- Note that 0.25ps RMS is to be used in channel simulations to account for additional noise in a real system.
- Note that 0.15ps RMS is to be used in channel simulations to account for additional noise in a real system.
- Note that 0.10ps RMS is to be used in channel simulations to account for additional noise in a real system.
- The *PCI Express Base Specification 7.0* provides the filters necessary to calculate IR jitter values; it does not provide specification limits, therefore, the reference to this footnote. IR values are informative only. A common practice is to split the common clock budget in half. For 16GT/s data rates and above, the user must choose whether to use the output jitter specification, or the input jitter specification, which includes an allocation for the jitter added by the channel. Using 32GT/s, the Refclk output jitter budget is 150fs RMS. One half of the Refclk jitter budget is 106fs RMS. At the clock input, the system must deliver a Refclk with <250fs RMS phase jitter. One half of this value is 177fs RMS. If the clock is placed next to the PCIe device in an IR system, the channel is very short and the user can choose to use this more relaxed value as the jitter limit.

**Table 11. Phase Jitter and Phase Noise – 1.8V VDDO [1][2]**

Symbol	Parameter	Conditions	Typical	Maximum	Unit
t <sub>jit</sub> (Φ)	Random Phase Jitter, 10kHz to 20MHz (78.125MHz XTAL, Synthesizer Mode) [2]	122.88MHz (VCO: 9.8304GHz, FOD 0, 1 or 2)	166	212	fs (RMS)
		156.25MHz (VCO: 10GHz, FOD 0, 1 or 2)	160	265	
		245.76MHz (VCO: 9.8304GHz, FOD 0, 1 or 2)	190	261	
		312.5MHz (VCO: 10GHz, FOD 0, 1 or 2)	137	227	
		322.265625MHz (VCO: 10.3125GHz, FOD 0, 1 or 2)	138	173	
		644.53125MHz (VCO: 10.3125GHz, FOD 0, 1 or 2)	125	155	

- Electrical parameters are guaranteed over the specified ambient operating temperature range, which is established when the device is mounted in a test socket with maintained transverse airflow greater than 500lfpm. The device will meet specifications after thermal equilibrium has been reached under these conditions.
- Characterized using a Rohde and Schwarz SMA100 overdriving the XTAL interface.

**Table 12. Phase Jitter and Phase Noise – 2.5V VDDO [1][2]**

Symbol	Parameter	Conditions	Typical	Maximum	Unit
tjit( $\Phi$ )	Random Phase Jitter, 10kHz to 20MHz (78.125MHz XTAL, Synthesizer Mode) [2]	122.88MHz (VCO: 9.8304GHz, FOD 0, 1 or 2)	178	227	fs (RMS)
		156.25MHz (VCO: 10GHz, FOD 0, 1 or 2)	169	247	
		245.76MHz (VCO: 9.8304GHz, FOD 0, 1 or 2)	209	228	
		312.5MHz (VCO: 10GHz, FOD 0, 1 or 2)	149	166	
		322.265625MHz (VCO: 10.3125GHz, FOD 0, 1 or 2)	156	278	
		644.53125MHz (VCO: 10.3125GHz, FOD 0, 1 or 2)	155	250	

1. Electrical parameters are guaranteed over the specified ambient operating temperature range, which is established when the device is mounted in a test socket with maintained transverse airflow greater than 500lfpm. The device will meet specifications after thermal equilibrium has been reached under these conditions.
2. Characterized using a Rohde and Schwarz SMA100 overdriving the XTAL interface.

**Table 13. Phase Jitter and Phase Noise – 3.3V VDDO [1][2]**

Symbol	Parameter	Conditions	Typical	Maximum	Unit
tjit( $\Phi$ )	Random Phase Jitter, 10kHz to 20MHz (78.125MHz XTAL, Synthesizer Mode) [2]	122.88MHz (VCO: 9.8304GHz, FOD 0, 1 or 2)	168	218	fs (RMS)
		156.25MHz (VCO: 10GHz, FOD 0, 1 or 2)	164	226	
		245.76MHz (VCO: 9.8304GHz, FOD 0, 1 or 2)	206	234	
		312.5MHz (VCO: 10GHz, FOD 0, 1 or 2)	145	192	
		322.265625MHz (VCO: 10.3125GHz, FOD 0, 1 or 2)	154	188	
		644.53125MHz (VCO: 10.3125GHz, FOD 0, 1 or 2)	141	162	

1. Electrical parameters are guaranteed over the specified ambient operating temperature range, which is established when the device is mounted in a test socket with maintained transverse airflow greater than 500lfpm. The device will meet specifications after thermal equilibrium has been reached under these conditions.
2. Characterized using a Rohde and Schwarz SMA100 overdriving the XTAL interface.

**Table 14. Clock Input Frequencies [1]**

Symbol	Parameter	Conditions	Minimum	Typical	Maximum	Unit
f <sub>INAPLL</sub>	APLL Input Frequency for clock generation.	Over-driving Crystal Input, Doubler Logic Disabled	1	-	650	MHz
		Over-driving Crystal Input, Doubler Logic Enabled	1	-	250	
		CLKIN[1:0] Differential Mode	1	-	650	
		CLKIN[1:0] Single-ended Mode	1	-	250	

1. For crystal characteristics, see [Table 15](#).

Table 15. External Crystal Characteristics

Symbol	Parameter	Conditions	Minimum	Typical	Maximum	Unit
-	Resonance Mode	-	Fundamental			-
$f_{\text{INXTAL}}^{[1]}$	Crystal input frequency	Fundamental mode	8	-	80	MHz
ESR <sup>[1]</sup>	Equivalent Series Resistance	$8\text{MHz} \leq f_{\text{INXTAL}} \leq 12\text{MHz}, C_L = 12\text{pF}$	-	-	120	$\Omega$
		$12\text{MHz} < f_{\text{INXTAL}} \leq 28\text{MHz}, C_L = 12\text{pF}$	-	-	80	
		$28\text{MHz} < f_{\text{INXTAL}} \leq 54\text{MHz}, C_L = 12\text{pF}$	-	-	50	
		$54\text{MHz} < f_{\text{INXTAL}} \leq 80\text{MHz}, C_L = 8\text{pF}$	-	-	50	
$C_O^{[1]}$	Shunt Capacitance	-	-	7	-	pF
$C_L^{[1]}$	Load Capacitance	-	6	8	12	
Drive <sup>[1]</sup>	Drive Level	-	-	-	100	$\mu\text{W}$
$F_{\text{TOL}}$	Frequency Tolerance	Center frequency at 25°C	-	-	[2]	ppm
$F_{\text{STAB}}$	Frequency Stability	Over Operating Temperature Range with respect to $F_{\text{TOL}}$	-	-		
Aging	Per Year	-	-	-		

1. These parameters are required, regardless of crystal used.

2. These parameters are customer/application dependent. Common maximum values are  $F_{\text{TOL}} = \pm 20\text{ppm}$ ,  $F_{\text{STAB}} = \pm 20\text{ppm}$ , and Aging =  $\pm 5\text{ppm}/10\text{years}$ . The customer is free to adjust these parameters to their particular requirements.

Table 16. Internal Crystal Characteristics (Q Versions Only)

Symbol	Parameter	Conditions	Minimum	Typical	Maximum	Unit
-	Resonance Mode	-	Fundamental			-
$f_{\text{INXTAL}}$	Crystal frequency	Fundamental mode	-	78.125	-	MHz
$F_{\text{STAB}}$	Frequency Stability	Includes both initial accuracy and variation over temperature.	-	-	$\pm 30$	ppm
-	Aging	Over the first ten years	-	-	$\pm 5$	

Table 17. Output Enable/Disable Timing <sup>[1]</sup>

Symbol	Parameter	Conditions	Minimum	Typical	Maximum	Unit
$t_{\text{OE}}$	Output Enable/Disable Time	Synchronous Glitch-Free Mode. Any GPI/GPIO configured as group OE or global OE, any output type. Differential clock types are referenced to true output.	4 + 1 clock period	-	12 + 2 clock periods	ns
		Asynchronous Non-Glitch-Free Mode. Any GPI/GPIO configured as group OE or global OE, any output type. Differential clock types are referenced to true output. [2]	4	-	12	ns

1. The enable/disable circuit incurs a 1 or 2 clock period delay to insure glitch-free start and stop of the outputs. The clock period specified is the period of the output clock. If an OE is used to control different output frequencies, the period of the lowest output frequency should be used.

2. Asynchronous Non-Glitch-Free Mode is sometimes referred to as Squelch Mode. This mode does not synchronize the enable/disable signal to the output and may result in glitches or runt pulses on the outputs.

**Table 18. Output Frequencies and Startup Times [1]**

Symbol	Parameter	Conditions	Minimum	Typical	Maximum	Unit
f <sub>OUT</sub>	Output Frequency	Differential Output.	0.001	-	650	MHz
		LVC MOS Output.	0.001	-	200	
f <sub>MON</sub>	Reference Monitor Operating Frequency	-	-	-	40	MHz
f <sub>VCO</sub>	VCO (APLL) Operating Frequency	-	9.5	-	10.7	GHz
t <sub>STARTUP</sub>	Start-up Time [2][3]	Synthesizer mode	-	6	10	ms

1. Electrical parameters are guaranteed over the specified ambient operating temperature range, which is established when the device is mounted in a test socket with maintained transverse airflow greater than 500lfpm. The device will meet specifications after thermal equilibrium has been reached under these conditions.
2. Measured from when all power supplies have reached > 90% of nominal voltage to the first stable clock edge on the output. A stable clock is defined as one generated from a locked PLL (as appropriate for the configuration listed) with no further perturbations in frequency expected. Includes time needed to load a configuration from internal OTP. For important additional power supply sequencing considerations, see [Power Considerations](#).
3. Start-up time will depend on the actual configuration used. For more information, please contact Renesas technical support

**Table 19. Output-to-Output, Input-to-Output Skew – LP-HCSL Outputs 1.8V/2.5V/3.3V VDDO [1]**

Symbol	Parameter	Conditions	Minimum	Typical	Maximum	Unit
t <sub>SK</sub>	Output-to-Output Skew [2][3]	FOD1 driving output banks [2:4]	-	18	90	ps
		FOD1 driving all output banks	-	39	124	
		FOD1 driving Bank2	-	21	63	
		IOD1 driving bank 2	-	22	65	
t <sub>PD</sub>	Input-to-Output Delay [3][4]	Fanout buffer path to any output	1.2	2	2.6	ns
Δt <sub>PD</sub>	Input-to-Output Delay Variation [3][4]	Fanout buffer, single device, at a fixed voltage, over temperature	-	2	4	ps/°C

1. Electrical parameters are guaranteed over the specified ambient operating temperature range, which is established when the device is mounted in a test socket with maintained transverse airflow greater than 500lfpm. The device will meet specifications after thermal equilibrium has been reached under these conditions.
2. Defined as the time between the rising edges of two outputs of the same frequency, configuration, loading, and supply voltage.
3. This parameter is defined in accordance with JEDEC Standard 65
4. Defined as the time between to output rising edge and the input rising edge that caused it.

**Table 20. Output-to-Output, Input-to-Output Skew – LVDS Outputs 1.8V/2.5V/3.3V VDDO [1]**

Symbol	Parameter	Conditions	Minimum	Typical	Maximum	Unit
t <sub>SK</sub>	Output-to-Output Skew [2][3]	FOD1 driving output banks [2:4]	-	16	93	ps
		FOD1 driving all output banks	-	44	101	
		FOD1 driving Bank2	-	14	53	
		IOD1 driving bank 2	-	20	67	
t <sub>PD</sub>	Input-to-Output Delay [3][4]	Fanout buffer path to any output	1.3	2	2.8	ns

1. Electrical parameters are guaranteed over the specified ambient operating temperature range, which is established when the device is mounted in a test socket with maintained transverse airflow greater than 500lfpm. The device will meet specifications after thermal equilibrium has been reached under these conditions.
2. Defined as the time between the rising edges of two outputs of the same frequency, configuration, loading, and supply voltage.
3. This parameter is defined in accordance with JEDEC Standard 65
4. Defined as the time between to output rising edge and the input rising edge that caused it.

**Table 21. Output-to-Output, Input-to-Output Skew – LVCMOS Outputs 1.8V/2.5V/3.3V VDDO [1]**

Symbol	Parameter	Conditions	Minimum	Typical	Maximum	Unit
t <sub>SK</sub>	Output-to-Output Skew [2][3]	FOD1 driving output banks [2:4]	-	50	130	ps
		FOD1 driving all output banks	-	76	180	
		FOD1 driving Bank2	-	22	64	
		IOD1 driving bank 2	-	29	79	
t <sub>PD</sub>	Input-to-Output Delay [3][4]	Fanout buffer path to any output - 1.8V VDDO	2.3	3.2	4.3	ns
		Fanout buffer path to any output - 2.5V VDDO	1.7	2.4	3.4	
		Fanout buffer path to any output - 3.3V VDDO	1.6	2.2	3	

1. Electrical parameters are guaranteed over the specified ambient operating temperature range, which is established when the device is mounted in a test socket with maintained transverse airflow greater than 500fpm. The device will meet specifications after thermal equilibrium has been reached under these conditions.
2. Defined as the time between the rising edges of two outputs of the same frequency, configuration, loading, and supply voltage.
3. This parameter is defined in accordance with JEDEC Standard 65
4. Defined as the time between to output rising edge and the input rising edge that caused it.

**Table 22. Static Phase Offset - Zero Delay Buffer Mode**

Symbol	Parameter	Conditions	Minimum	Typical	Maximum	Unit
t <sub>ΦAPLL</sub>	APLL Static Phase Offset [1]	LVDS or LP-HCSL signaling, feedback frequency = 50MHz. VDDR = VDDOx = 2.5V or 3.3V. CLKIN0 used as feedback in.	-	197	270	ps
		LVDS or LP-HCSL signaling, feedback frequency = 50MHz. VDDR = VDDOx = 1.8V. CLKIN0 used as feedback in.	-	192	350	

1. This parameter is defined in accordance with JEDEC Standard 65B, which defines static phase offset as the time interval between similar points on the waveforms of the averaged input reference clock and the averaged feedback input signal when the PLL is locked and the input reference frequency is stable.

**Table 23. LVCMOS AC/DC Output Characteristics – 1.8V VDDO[1]**

Symbol	Parameter	Conditions	Minimum	Typical	Maximum	Unit
V <sub>OH</sub>	Output High Voltage [2]	I <sub>OH</sub> = -2mA	1.6	1.75	VDDO + 0.3	V
V <sub>OL</sub>	Output Low Voltage [2]	I <sub>OL</sub> = 2mA	-	0.04	0.4	
I <sub>OZ</sub>	Output Leakage Current	Outputs Tri-stated	-5	-	5	μA
dV/dt	Slew Rate[3]	ODRV_CNFG[3:2] = 0	0.8	1.5	2.2	V/ns
		ODRV_CNFG[3:2] = 1	0.7	1.5	2.2	
		ODRV_CNFG[3:2] = 2	0.7	1.5	2.4	
		ODRV_CNFG[3:2] = 3	0.8	1.5	2.3	
t <sub>DC</sub>	Output Duty Cycle	V <sub>T</sub> = VDDO/2	45	51	55	%

1. See Test Loads for additional information.
2. These values are compliant with JESD8-7A.
3. V<sub>T</sub> = 20% to 80% of VDDO, C<sub>L</sub> = 4.7pF.

Table 24. LVCMOS AC/DC Output Characteristics – 2.5V VDDO<sup>[1]</sup>

Symbol	Parameter	Conditions	Minimum	Typical	Maximum	Unit
V <sub>OH</sub>	Output High Voltage <sup>[2]</sup>	I <sub>OH</sub> = -2mA	2.2	2.4	VDDO + 0.3	V
V <sub>OL</sub>	Output Low Voltage <sup>[2]</sup>	I <sub>OL</sub> = 2mA	-	0.04	0.4	
I <sub>OZ</sub>	Output Leakage Current	Outputs Tri-stated	-5	-	5	μA
dV/dt	Slew Rate <sup>[3]</sup>	ODRV_CNFG[3:2] = 0	1.2	2.2	3.6	V/ns
		ODRV_CNFG[3:2] = 1	0,6	1.6	3.2	
		ODRV_CNFG[3:2] = 2	0,5	1.4	2.6	
		ODRV_CNFG[3:2] = 3	0.9	2.0	3.4	
t <sub>DC</sub>	Output Duty Cycle	V <sub>T</sub> = VDDO/2	45	51	55	%

1. See Test Loads for additional information.
2. These values are compliant with JESD8-5A.01.
3. V<sub>T</sub> = 20% to 80% of VDDO, C<sub>L</sub> = 4.7pF.

Table 25. LVCMOS AC/DC Output Characteristics – 3.3V VDDO<sup>[1]</sup>

Symbol	Parameter	Conditions	Minimum	Typical	Maximum	Unit
V <sub>OH</sub>	Output High Voltage <sup>[2]</sup>	I <sub>OH</sub> = -2mA	2.4	3.2	VDDO + 0.3	V
V <sub>OL</sub>	Output Low Voltage <sup>[2]</sup>	I <sub>OL</sub> = 2mA	-	0.03	0.4	
I <sub>OZ</sub>	Output Leakage Current	Outputs Tri-stated	-5	-	5	μA
dV/dt	Slew Rate <sup>[3]</sup>	ODRV_CNFG[3:2] = 0	1.3	3.1	4.9	V/ns
		ODRV_CNFG[3:2] = 1	1.2	2.5	4.0	
		ODRV_CNFG[3:2] = 2	1.2	2.4	4.0	
		ODRV_CNFG[3:2] = 3	1.4	2.8	4.1	
t <sub>DC</sub>	Output Duty Cycle	V <sub>T</sub> = VDDO/2	45	50.7	55	%

1. See Test Loads for additional information.
2. These values are compliant with JESD8C.01.
3. V<sub>T</sub> = 20% to 80% of VDDO, C<sub>L</sub> = 4.7pF.

Table 26. LVDS AC/DC Output Characteristics – 1.8V V<sub>DDO</sub><sup>[1]</sup>

Symbol	Parameter	Conditions	Minimum	Typical	Maximum	Unit
V <sub>OT</sub> (+)	TRUE binary state.	out_prog = 0x00	243	346	448	mV
V <sub>OT</sub> (-)	FALSE binary state.		-462	-355	-248	
V <sub>OT</sub> (+)	TRUE binary state.	out_prog = 0x01	257	362	468	mV
V <sub>OT</sub> (-)	FALSE binary state.		-482	-372	-262	
V <sub>OT</sub> (+)	TRUE binary state.	out_prog = 0x02	219	310	400	mV
V <sub>OT</sub> (-)	FALSE binary state.		-419	-323	-227	
V <sub>OT</sub> (+)	TRUE binary state.	out_prog = 0x03	232	328	425	mV
V <sub>OT</sub> (-)	FALSE binary state.		-441	-338	-235	
ΔV <sub>OT</sub>	Change in V <sub>OT</sub> between Complimentary Output States	-	14	37	60	mV
V <sub>CMR</sub>	Output Common Mode Voltage	-	1.07	1.21	1.35	V
ΔV <sub>CMR</sub>	Change in V <sub>CMR</sub> between Complimentary Output States	-	-	25	37	mV

Table 26. LVDS AC/DC Output Characteristics – 1.8V V<sub>DDO</sub> [1] (Cont.)

Symbol	Parameter	Conditions	Minimum	Typical	Maximum	Unit
I <sub>OS</sub>	Output Short Circuit Current	V <sub>OUT+</sub> or V <sub>OUT-</sub> = 0V or VDD	-	7.5	-	mA
I <sub>OSD</sub>	Differential Output Short Circuit Current	V <sub>OUT+</sub> = V <sub>OUT-</sub>	-	3.3	-	
t <sub>R</sub> /t <sub>F</sub>	Rise/Fall Time [2] V <sub>T</sub> = 20% to 80% of swing.	-	138	252	365	ps
t <sub>DC</sub>	Output Duty Cycle [3]	f ≤ 400MHz, V <sub>T</sub> = 0V.	45	49.7	55	%
		f > 400MHz., V <sub>T</sub> = 0V.	43.9	49.7	56.1	%

1. See Test Loads for additional test conditions.
2. Single-ended measurement
3. Measured from differential waveform.

Table 27. LVDS AC/DC Output Characteristics – 2.5V/3.3V V<sub>DDO</sub> [1]

Symbol	Parameter	Conditions	Minimum	Typical	Maximum	Unit
V <sub>OT</sub> (+)	TRUE binary state.	out_prog = 0x00	240	348	457	mV
V <sub>OT</sub> (-)	FALSE binary state.		-464	-356	-247	
V <sub>OT</sub> (+)	TRUE binary state.	out_prog = 0x01	255	366	477	mV
V <sub>OT</sub> (-)	FALSE binary state.		-483	-372	-261	
V <sub>OT</sub> (+)	TRUE binary state.	out_prog = 0x02	211	311	411	mV
V <sub>OT</sub> (-)	FALSE binary state.		-427	-325	-224	
V <sub>OT</sub> (+)	TRUE binary state.	out_prog = 0x03	225	330	434	mV
V <sub>OT</sub> (-)	FALSE binary state.		-446	-341	-235	
ΔV <sub>OT</sub>	Change in V <sub>OT</sub> between Complimentary Output States	-	14	37	60	mV
V <sub>CMR</sub>	Output Common Mode Voltage	-	1.16	1.21	1.32	V
ΔV <sub>CMR</sub>	Change in V <sub>CMR</sub> between Complimentary Output States	-	-	25	37	mV
I <sub>OS</sub>	Output Short Circuit Current	V <sub>OUT+</sub> or V <sub>OUT-</sub> = 0V or VDD	-	7.5	-	mA
I <sub>OSD</sub>	Differential Output Short Circuit Current	V <sub>OUT+</sub> = V <sub>OUT-</sub>	-	3.3	-	
t <sub>R</sub> /t <sub>F</sub>	Rise/Fall Time [2] V <sub>T</sub> = 20% to 80% of swing.	-	138	252	365	ps
t <sub>DC</sub>	Output Duty Cycle [3]	f ≤ 400MHz, V <sub>T</sub> = 0V.	45	49.7	55	%
		f > 400MHz, V <sub>T</sub> = 0V.	43.9	49.7	56.1	%

1. See Test Loads for additional test conditions.
2. Single-ended measurement
3. Measured from differential waveform.

Table 28. LP-HCSL AC/DC Characteristics, Non-PCIe Frequencies – 1.8V V<sub>DDO</sub><sup>[1]</sup>

Symbol	Parameter	Conditions	Minimum	Typical	Maximum	Unit	
V <sub>OH</sub>	Output High Voltage [2] f < 400MHz	V <sub>HIGH</sub> = 800mV, Fast Slew Rate, 25MHz, 100MHz, 156.25MHz, 312.5MHz or 625MHz.	680	849	1018	mV	
	Output High Voltage [2] f ≥ 400MHz		522	657	792		
V <sub>OL</sub>	Output Low Voltage [2]		-130	-4	123		
V <sub>CROSS</sub>	Crossing Voltage (abs) [3]		166	423	680		
ΔV <sub>CROSS</sub>	Crossing Voltage (var) [3][4][5]		-	30	43		
t <sub>R</sub> /t <sub>F</sub>	Rise/Fall Time [2] V <sub>T</sub> = 20% to 80% of swing, f < 400MHz		232	392	552	ps	
	Rise/Fall Time [2] V <sub>T</sub> = 20% to 80% of swing, f ≥ 400MHz		160	300	439		
V <sub>OH</sub>	Output High Voltage [2] f < 400MHz		V <sub>HIGH</sub> = 900mV, Fast Slew Rate, 25MHz, 100MHz, 156.25MHz, 312.5MHz or 625MHz.	718	924	1130	mV
	Output High Voltage [2] f ≥ 400MHz			551	703	855	
V <sub>OL</sub>	Output Low Voltage [2]			-164	-2	160	
V <sub>CROSS</sub>	Crossing Voltage (abs) [3]	170		446	722		
ΔV <sub>CROSS</sub>	Crossing Voltage (var) [3][4][5]	-		27	41		
t <sub>R</sub> /t <sub>F</sub>	Rise/Fall Time [2] V <sub>T</sub> = 20% to 80% of swing, f < 400MHz	217		402	588	ps	
	Rise/Fall Time [2] V <sub>T</sub> = 20% to 80% of swing, f ≥ 400MHz	169		298	428		
t <sub>DC</sub>	Output Duty Cycle [6]	Across all settings, f < 400MHz V <sub>T</sub> = 0V.		47	50	53	%
		Across all settings, f ≥ 400MHz V <sub>T</sub> = 0V.		45	50	55	

1. Standard high impedance load with C<sub>L</sub> = 2pF. See Test Loads
2. Measured from single-ended waveform.
3. Measured at crossing point where the instantaneous voltage value of the rising edge of CLK equals the falling edge of CLKb.
4. Refers to the total variation from the lowest crossing point to the highest, regardless of which edge is crossing. Refers to all crossing points for this measurement.
5. Defined as the total variation of all crossing voltages of Rising CLK and Falling CLKb. This is the maximum variance in V<sub>CROSS</sub> for any particular system.
6. Measured from differential waveform.

Table 29. LP-HCSL AC/DC Characteristics, Non-PCIe Frequencies – 2.5V/3.3V V<sub>DDO</sub> [1]

Symbol	Parameter	Conditions	Minimum	Typical	Maximum	Unit	
V <sub>OH</sub>	Output High Voltage [2] f < 400MHz.	V <sub>HIGH</sub> = 800mV, Fast Slew Rate, 25MHz, 100MHz, 156.25MHz, 312.5MHz or 625MHz.	667	861	1055	mV	
	Output High Voltage [2] f ≥ 400MHz.		552	717	881	mV	
V <sub>OL</sub>	Output Low Voltage [2]		-164	-4	156	mV	
V <sub>CROSS</sub>	Crossing Voltage (abs) [3]		261	384	507	mV	
ΔV <sub>CROSS</sub>	Crossing Voltage (var) [3][4][5]		-	27	42	mV	
t <sub>R</sub> /t <sub>F</sub>	Rise/Fall Time [2] V <sub>T</sub> = 20% to 80% of swing, f < 400MHz.		214	393	606	ps	
	Rise/Fall Time [2] V <sub>T</sub> = 20% to 80% of swing f ≥ 400MHz		148	302	456		
V <sub>OH</sub>	Output High Voltage [2] f < 400MHz.		V <sub>HIGH</sub> = 900mV, Fast Slew Rate, 25MHz, 100MHz, 156.25MHz, 312.5MHz or 625MHz.	694	917	1140	mV
	Output High Voltage [2] f ≥ 400MHz.			598	757	917	mV
V <sub>OL</sub>	Output Low Voltage [2]			-164	-8	148	mV
V <sub>CROSS</sub>	Crossing Voltage (abs) [3]	238		455	673	mV	
ΔV <sub>CROSS</sub>	Crossing Voltage (var) [3][4][5]	-		27	42	mV	
t <sub>R</sub> /t <sub>F</sub>	Rise/Fall Time [2] V <sub>T</sub> = 20% to 80% of swing, f < 400MHz.	218		397	581	ps	
	Rise/Fall Time [2] V <sub>T</sub> = 20% to 80% of swing f ≥ 400MHz	174		300	426		
t <sub>DC</sub>	Output Duty Cycle [6]	Across all settings, f < 400MHz V <sub>T</sub> = 0V.		48	50	52	%
		Across all settings, f ≥ 400MHz V <sub>T</sub> = 0V.		45	50	55	

- Standard high impedance load with C<sub>L</sub>= 2pF. See Test Loads.
- Measured from single-ended waveform.
- Measured at crossing point where the instantaneous voltage value of the rising edge of CLK equals the falling edge of CLKb.
- Refers to the total variation from the lowest crossing point to the highest, regardless of which edge is crossing. Refers to all crossing points for this measurement.
- Defined as the total variation of all crossing voltages of Rising CLK and Falling CLKb. This is the maximum allowed variance in V<sub>CROSS</sub> for any particular system.
- Measured from differential waveform.

Table 30. LP-HCSL AC/DC Characteristics, 100MHz PCIe – 1.8V V<sub>DDO</sub> [1]

Symbol	Parameter	Conditions	Minimum	Typical	Maximum	Spec. Limit [2]	Unit
V <sub>MAX</sub>	Absolute Max Voltage Includes 300mV of overshoot (Vovs) [3][4]	V <sub>HIGH</sub> set to 900mV.	-	-	1103	1150	mV
V <sub>MIN</sub>	Absolute Min Voltage Includes -300mV of undershoot (Vuds) [3][5]		-152	-	-	-300	
V <sub>HIGH</sub>	Voltage High [3]	V <sub>HIGH</sub> set to 800mV.	825	886	984	-	mV
V <sub>LOW</sub>	Voltage Low [3]		-70	-15	44	-	
V <sub>CROSS</sub>	Crossing Voltage (abs) [3][6][7]	V <sub>HIGH</sub> set to 800mV, scope averaging off.	266	406	545	250 to 550	
ΔV <sub>CROSS</sub>	Crossing Voltage (var) [3][6][8]		-	27	49	140	
dv/dt	Slew rate [9][10]	V <sub>HIGH</sub> set to 800mV, Fast slew rate, scope averaging on.	1.6	2.6	3.6	1 to 4	V/ns
		V <sub>HIGH</sub> set to 800mV, Slow slew rate, scope averaging on.	1.2	1.8	2.4		
ΔT <sub>R/F</sub>	Rise/fall matching [3][11]	V <sub>HIGH</sub> set to 800mV. Fast or slow slew rate.	-	7	19.3	20	%
V <sub>HIGH</sub>	Voltage High [3]	V <sub>HIGH</sub> set to 900mV.	844	940	1037	-	mV
V <sub>LOW</sub>	Voltage Low [3]		-79	-14	51	-	
V <sub>CROSS</sub>	Crossing Voltage (abs) [3][6][7]	V <sub>HIGH</sub> set to 900mV, scope averaging off.	301	451	600	300 to 600	
ΔV <sub>CROSS</sub>	Crossing Voltage (var) [3][6][8]		-	28	44	140	
dv/dt	Slew rate [9][10]	V <sub>HIGH</sub> set to 900mV, Fast slew rate, scope averaging on.	1.7	2.7	3.7	1 to 4	V/ns
		V <sub>HIGH</sub> set to 900mV, Slow slew rate, scope averaging on.	1.3	1.9	2.5		
ΔT <sub>R/F</sub>	Rise/fall matching [3][11]	V <sub>HIGH</sub> set to 900mV. Fast or slow slew rate.	-	4	18.5	20	%
t <sub>DC</sub>	Output Duty Cycle [9]	V <sub>T</sub> = 0V.	49	50	51	45 to 55	
t <sub>jyc-cyc</sub>	Jitter, Cycle to cycle [9]	Across all settings in this table at 100MHz.	-	33	49.3	50	ps

- Standard high impedance load with C<sub>L</sub> = 2pF. See Test Loads.
- The specification limits are taken from either the *PCIe Base Specification Revision 7.0* or from relevant x86 processor specifications, whichever is more stringent.
- Measured from single-ended waveform.
- Defined as the maximum instantaneous voltage including overshoot.
- Defined as the minimum instantaneous voltage including undershoot.
- Measured at crossing point where the instantaneous voltage value of the rising edge of REFCLK+ equals the falling edge of REFCLK-.
- Refers to the total variation from the lowest crossing point to the highest, regardless of which edge is crossing. Refers to all crossing points for this measurement.
- Defined as the total variation of all crossing voltages of Rising REFCLK+ and Falling REFCLK-. This is the maximum allowed variance in V<sub>CROSS</sub> for any particular system.
- Measured from differential waveform.
- Measured from -150 mV to +150 mV on the differential waveform (derived from REFCLK+ minus REFCLK-). The signal must be monotonic through the measurement region for rise and fall time. The 300 mV measurement window is centered on the differential zero crossing.
- Matching applies to rising edge rate for REFCLK+ and falling edge rate for REFCLK-. It is measured using a ±75 mV window centered on the median cross point where REFCLK+ rising meets REFCLK- falling. The median cross point is used to calculate the voltage thresholds the oscilloscope is to use for the edge rate calculations. The Rise Edge Rate of REFCLK+ should be compared to the Fall Edge Rate of REFCLK-; the maximum allowed difference should not exceed 20% of the slowest edge rate.

Table 31. LP-HCSL AC/DC Characteristics, 100MHz PCIe – 2.5V/3.3V V<sub>DDO</sub> [1]

Symbol	Parameter	Conditions	Minimum	Typical	Maximum	Spec. Limit [2]	Unit
V <sub>MAX</sub>	Absolute Max Voltage Includes 300mV of overshoot (Vovs) [3][4]	V <sub>HIGH</sub> set to 900mV.	-	-	1088	1150	mV
V <sub>MIN</sub>	Absolute Min Voltage Includes -300mV of undershoot (Vuds) [3][5]		-174	-	-	-300	
V <sub>HIGH</sub>	Voltage High [3]	V <sub>HIGH</sub> set to 800mV.	743	869	994	-	mV
V <sub>LOW</sub>	Voltage Low [3]		-92	-7	58	-	
V <sub>CROSS</sub>	Crossing Voltage (abs) [3][6][7]	V <sub>HIGH</sub> set to 800mV, scope averaging off.	256	406	533	250 to 550	
ΔV <sub>CROSS</sub>	Crossing Voltage (var) [3][6][8]		-	27	40	140	
dv/dt	Slew rate [9][10]	V <sub>HIGH</sub> set to 800mV, Fast slew rate, scope averaging on.	1.3	2.6	3.9	1 to 4	V/ns
		V <sub>HIGH</sub> set to 800mV, Slow slew rate, scope averaging on.	1	1.7	3.1		
ΔT <sub>R/F</sub>	Rise/fall matching [3][11]	V <sub>HIGH</sub> set to 800mV. Fast or slow slew rate.	-	8	19.7	20	%
V <sub>HIGH</sub>	Voltage High [3]	V <sub>HIGH</sub> set to 900mV.	800	925	1051	-	mV
V <sub>LOW</sub>	Voltage Low [3]		-95	-2	68	-	
V <sub>CROSS</sub>	Crossing Voltage (abs) [3][6][7]	V <sub>HIGH</sub> set to 900mV, scope averaging off.	286	454	629	250 to 600	
ΔV <sub>CROSS</sub>	Crossing Voltage (var) [3][6][8]		-	27	40	140	
dv/dt	Slew rate [9][10]	V <sub>HIGH</sub> set to 900mV, Fast slew rate, scope averaging on.	1.4	2.8	4.2	1 to 4.2	V/ns
		V <sub>HIGH</sub> set to 900mV, Slow slew rate, scope averaging on.	1.2	2.0	3		
ΔT <sub>R/F</sub>	Rise/fall matching [3][11]	V <sub>HIGH</sub> set to 900mV. Fast or slow slew rate.	-	6	18.7	20	%
t <sub>DC</sub>	Output Duty Cycle [9]	V <sub>T</sub> = 0V.	49	50	51	45 to 55	
t <sub>jycy-cyc</sub>	Jitter, Cycle to cycle [9]	Across all settings in this table at 100MHz.	-	30	48.3	50	ps

- Standard high impedance load with C<sub>L</sub> = 2pF. See Test Loads.
- The specification limits are taken from either the *PCIe Base Specification Revision 7.0* or from relevant x86 processor specifications, whichever is more stringent.
- Measured from single-ended waveform.
- Defined as the maximum instantaneous voltage including overshoot.
- Defined as the minimum instantaneous voltage including undershoot.
- Measured at crossing point where the instantaneous voltage value of the rising edge of REFCLK+ equals the falling edge of REFCLK-.
- Refers to the total variation from the lowest crossing point to the highest, regardless of which edge is crossing. Refers to all crossing points for this measurement.
- Defined as the total variation of all crossing voltages of Rising REFCLK+ and Falling REFCLK-. This is the maximum allowed variance in V<sub>CROSS</sub> for any particular system.
- Measured from differential waveform.
- Measured from -150 mV to +150 mV on the differential waveform (derived from REFCLK+ minus REFCLK-). The signal must be monotonic through the measurement region for rise and fall time. The 300 mV measurement window is centered on the differential zero crossing.
- Matching applies to rising edge rate for REFCLK+ and falling edge rate for REFCLK-. It is measured using a ±75 mV window centered on the median cross point where REFCLK+ rising meets REFCLK- falling. The median cross point is used to calculate the voltage thresholds the oscilloscope is to use for the edge rate calculations. The Rise Edge Rate of REFCLK+ should be compared to the Fall Edge Rate of REFCLK-; the maximum allowed difference should not exceed 20% of the slowest edge rate.

Table 32. 100MHz PCIe Output Clock Accuracy and SSC

Symbol	Parameter	Conditions	Minimum	Typical	Maximum	PCIe Limit <sup>[1]</sup>	Unit
T <sub>PERIOD_AVG_32G_64G_CC</sub>	Average Clock Period Accuracy for devices supporting 32GT/s or 64GT/s CC mode at any speed. [2][3]	SSC ≤ -0.5%, includes spread-spectrum modulation, if any.	0	-	2410	-100 to +2600	ppm
T <sub>PERIOD_AVG_32G_64G_SRIS</sub>	Average Clock Period Accuracy for devices supporting 32GT/s SRIS mode at any speed. [2][3]	SSC ≤ -0.3%, includes spread-spectrum modulation, if any.	0	-	1430	-100 to +1600	
T <sub>PERIOD_AVG_32G_64G</sub>	Average Clock Period Accuracy for devices supporting 32GT/s CC/SRNS mode at any speed. [2][3]	SSC = 0% (SSC Off).	0	-	0	±100	
T <sub>PERIOD_ABS_32G_64G_CC</sub>	Average Clock Period Accuracy for devices supporting 32GT/s CC mode at any speed. [2][4]	SSC ≤ -0.5%, includes jitter and spread-spectrum modulation.	10	-	10.024	9.849 to 10.201	ns
T <sub>PERIOD_ABS_32G_64G_SRIS</sub>	Average Clock Period Accuracy for devices supporting 32GT/s SRIS mode at any speed. [2][4]	SSC ≤ -0.3%, includes jitter and spread-spectrum modulation.	10	-	10.014	9.849 to 10.181	
T <sub>PERIOD_ABS_32G_64G</sub>	Average Clock Period Accuracy for devices supporting 32GT/s CC/SRNS mode at any speed. [2][4]	SSC = 0% (SSC Off), includes jitter.	10	-	10	9.849 to 10.151	
F <sub>REFCLK_32G_64G</sub>	Refclk Frequency for devices that support 32GT/s or 64GT/s.	SSC = 0% (SSC Off)	100	-	100	99.99 to 100.01	MHz
F <sub>SSC</sub>	SSC Modulation Frequency		31.2	31.5	31.9	30 to 33	kHz
T <sub>SSC_FREQ_DEV</sub>	SSC Deviation for all devices and architectures except 32GT/s or 64GT/s devices operating in SRIS mode.	SSC = -0.5%	-0.490	-0.488	-0.486	-0.5	%
T <sub>SSC_FREQ_DEV_32G_64G_SRIS</sub>	SSC Deviation for devices that support 32 or 64GT/s operating in SRIS mode, at any speeds.	SSC = -0.3%	-0.300	-0.295	-0.290	-0.3	%
T <sub>SSC_MAX_FREQ_SLEW</sub>	Max df/dt of the SSC. [5]	-	-	310	372	1250	ppm/us
T <sub>TRANSPORT_DELAY</sub>	Tx-Rx transport delay used for PCIe Jitter calculations. [6]	Applies to Common Clocked architectures only.	-	-	12	12	ns

1. The specification limits are taken from either the *PCIe Base Specification, Revision 7.0* or from relevant x86 processor specifications, whichever is more stringent.
2. Measured from differential waveform.
3. PPM refers to parts per million and is a DC absolute period accuracy specification. 1 PPM is 1/1,000,000th of 100.000000MHz exactly or 100Hz. For 100PPM, then we have an error budget of 100Hz/PPM \* 100PPM = 10kHz. The period is to be measured with a frequency counter with measurement window set to 100 ms or greater. The ±100PPM applies to systems that do not employ Spread-Spectrum Clocking, or that use common clock source. For systems employing Spread-Spectrum Clocking, there is an additional 2,500PPM nominal shift in maximum period resulting from the 0.5% down spread resulting in a maximum average period specification of +2,600PPM for Common Clock Architectures. SRIS Architectures may have a lower allowed spread percentage. Devices meeting these specifications automatically meet the less stringent -300ppm to +2800ppm tolerances for data rates ≤16GT/s. Refer to Section 8.6 of the *PCIe Base Specification, Revision 7.0*.
4. Defined as the absolute minimum or maximum instantaneous period. This includes cycle-to-cycle jitter, relative PPM tolerance, and spread-spectrum modulation. Devices meeting these specifications automatically meet the less stringent and 9.847ns to 10.203ns tolerances for data rates ≤16GT/s.
5. Measurement is made over a 0.5us time interval with a 1st order LPF with an fC of 60x the SSC modulation frequency (1.89MHz for 31.5kHz modulation frequency).
6. This is the default value used for all PCIe Common Clock architecture jitter calculations. There are form factors (for example topologies including long cables) that may exceed this limit. Contact Renesas for assistance calculating jitter if your topology exceeds 12ns.

**Table 33. Spread-Spectrum Programmability**

Symbol	Parameter	Conditions	Minimum	Typical	Maximum	Unit
f <sub>SSCMOD</sub>	SSC Modulation Frequency	Modulation frequency.	30	-	63	kHz
SSC%	Spread percentage [1]	Down Spread.	-1	-	-0.05	%
		Center Spread.	±0.025	-	±0.75	
f <sub>OUTSSC</sub>	Output frequency	Allowable output frequency range when SSC is enabled.	33	-	650	MHz

1. Spread off is 0%.

**Table 34. CLKIN Differential Electrical Characteristics [1]**

Symbol	Parameter	Conditions	Minimum	Typical	Maximum	Unit
V <sub>PP_DIF</sub>	Peak-to-Peak differential input voltage [2]	VDDR = 1.8V, 2.5V or 3.3V	0.3	-	2.2	V
V <sub>CMR_LOW</sub>	Common mode voltage range - low range setting [3]	VDDR = 1.8V	0.15	-	0.6	V
		VDDR = 2.5V or 3.3V	0.15	-	<V <sub>DDR</sub> /2	
V <sub>CMR_HIGH</sub>	Common mode voltage range - high range setting [3]	VDDR = 1.8V	0.75	-	V <sub>DDR</sub> -0.3	V
		VDDR = 2.5V or 3.3V	≥V <sub>DDR</sub> /2	-	V <sub>DDR</sub> -0.3	
t <sub>SLEW</sub>	CLKIN differential slew rate	20/80% threshold	0.5	-	-	V/ns

1. This table applies when CLKIN0 or CLKIN1 are used as differential input clocks. If used as single-ended input clocks, the values in the GPO/GPIO Electrical Characteristics tables apply. The DC input voltage limits specified in the GPI/GPIO Electrical Characteristics tables must be followed at all times. This means that an input clock with VPP\_DIF = 0.3V will have a wider range of allowable common mode voltages than an input clock with a higher VPP\_DIF.

2. This value is 2 x the single-ended amplitude of the CLKIN signal.

3. The correct setting is automatically selected by the RICBox design software.

**Table 35. GPI/GPIO Electrical Characteristics – 1.8V VDD, VDDR, or VDDX [1][2]**

Symbol	Parameter	Conditions	Minimum	Typical	Maximum	Unit
V <sub>IH</sub>	Input High Voltage [3]	XIN_REFIN, XOUT_REFINb, GPI[3:0], GPIO[4:0].	0.65 VDD	-	VDD + 0.3	V
V <sub>IL</sub>	Input Low Voltage [3]	XIN_REFIN, XOUT_REFINb, GPI[3:0], GPIO[4:0].	-0.3	-	0.35 VDD	
V <sub>OH</sub>	Output High Voltage [3]	GPIO[4:0], IOH = -2mA.	VDD - 0.45	-	VDD + 0.3	
V <sub>OL</sub>	Output Low Voltage [3]	GPIO[4:0], IOL = 2mA.	-	-	0.45	
V <sub>IH</sub>	Input High Voltage	GPIO[2:0], when set to tri-level.	0.75 VDD	-	VDD + 0.3	
V <sub>IM</sub>	Input Mid Voltage	GPIO[2:0], when set to tri-level.	0.45 VDD	-	0.55 VDD	
V <sub>IL</sub>	Input Low Voltage	GPIO[2:0], when set to tri-level.	-0.3	-	0.25 VDD	

1. Input specifications refer to signals XIN\_REFIN, XOUT\_REFINb, GPI[3:0], GPIO[4:0], when acting as inputs. Output specifications refer to signals GPIO[4:0], when acting as outputs. To determine which VDD pin is referenced for each group in Table 35, see GPI and GPIO VDD pin assignments in Pin Information. For SCL\_SCLK, SDA\_SDI, see the I2C/SMBus electrical characteristics Table 40 and Table 41.

2. CLKIN[1:0]/CLKIN[1:0]b used as two single-ended clocks rather than as a differential clock.

3. These values are compliant with JESD8-7A. These values only apply to XIN\_REFIN and XOUT\_REFINb when "Input Buffer" mode is selected. See the Applications section for more details.

**Table 36. GPI/GPIO Electrical Characteristics – 2.5V VDDD, VDDR, or VDDX [1][2]**

Symbol	Parameter	Conditions	Minimum	Typical	Maximum	Unit
V <sub>IH</sub>	Input High Voltage [3]	XIN_REFIN, XOUT_REFINb, GPI[3:0], GPIO[4:0].	1.7	-	VDD + 0.3	V
V <sub>IL</sub>	Input Low Voltage [3]	XIN_REFIN, XOUT_REFINb, GPI[3:0], GPIO[4:0].	-0.3	-	0.7	
V <sub>OH</sub>	Output High Voltage [3]	GPIO[4:0], IOH = -2mA.	1.7	-	VDD + 0.3	
V <sub>OL</sub>	Output Low Voltage [3]	GPIO[4:0], IOL = 2mA.	-	-	0.7	
V <sub>IH</sub>	Input High Voltage	GPIO[2:0], when set to tri-level.	0.75 VDD	-	VDD + 0.3	
V <sub>IM</sub>	Input Mid Voltage	GPIO[2:0], when set to tri-level.	0.45 VDD	-	0.55 VDD	
V <sub>IL</sub>	Input Low Voltage	GPIO[2:0], when set to tri-level.	-0.3	-	0.25 VDD	

1. Input specifications refer to signals XIN\_REFIN, XOUT\_REFINb, GPI[3:0], GPIO[4:0], when acting as inputs. Output specifications refer to signals GPIO[4:0], when acting as outputs. To determine which VDD pin is referenced for each group in Table 36, see GPI and GPIO VDD pin assignments in Pin Information. For SCL\_SCLK, SDA\_SDI, see the I2C/SMBus electrical characteristics Table 40 and Table 41.
2. CLKIN[1:0]/CLKIN[1:0]b used as two single-ended clocks rather than as a differential clock.
3. These values are compliant with JESD8-5A.01. These values only apply to XIN\_REFIN and XOUT\_REFINb when “Input Buffer” mode is selected. See the Applications section for more details.

**Table 37. GPI/GPIO Electrical Characteristics – 3.3V VDDD, VDDR, or VDDX [1][2]**

Symbol	Parameter	Conditions	Minimum	Typical	Maximum	Unit
V <sub>IH</sub>	Input High Voltage [3]	XIN_REFIN, XOUT_REFINb, GPI[3:0], GPIO[4:0].	2.2	-	VDD + 0.3	V
V <sub>IL</sub>	Input Low Voltage [3]	XIN_REFIN, XOUT_REFINb, GPI[3:0], GPIO[4:0].	-0.3	-	0.8	
V <sub>OH</sub>	Output High Voltage [3]	GPIO[4:0], IOH = -2mA.	2.4	-	VDD + 0.3	
V <sub>OL</sub>	Output Low Voltage [3]	GPIO[4:0], IOL = 2mA.	-	-	0.4	
V <sub>IH</sub>	Input High Voltage	GPIO[2:0], when set to tri-level.	0.75 VDD	-	VDD + 0.3	
V <sub>IM</sub>	Input Mid Voltage	GPIO[2:0], when set to tri-level.	0.45 VDD	-	0.55 VDD	
V <sub>IL</sub>	Input Low Voltage	GPIO[2:0], when set to tri-level.	-0.3	-	0.25 VDD	

1. Input specifications refer to signals XIN\_REFIN, XOUT\_REFINb, GPI[3:0], GPIO[4:0], when acting as inputs. Output specifications refer to signals GPIO[4:0], when acting as outputs. To determine which VDD pin is referenced for each group in Table 37, see GPI and GPIO VDD pin assignments in Pin Information. For SCL\_SCLK, SDA\_SDI, see the I2C/SMBus electrical characteristics Table 40 and Table 41.
2. CLKIN[1:0]/CLKIN[1:0]b used as two single-ended clocks rather than as a differential clock.
3. These values are compliant with JESD8-5A.01. These values only apply to XIN\_REFIN and XOUT\_REFINb when “Input Buffer” mode is selected. See the Applications section for more details.

**Table 38. CMOS GPI/GPIO Common Electrical Characteristics [1][2]**

Symbol	Parameter	Conditions	Minimum	Typical	Maximum	Unit
I <sub>IL</sub>	Input Leakage Current	Includes input pull up/pull down resistor current. V <sub>IL</sub> = 0V, V <sub>IH</sub> = V <sub>DD</sub> .	-15	-	15	μA

1. Input specifications refer to signals XIN\_REFIN, XOUT\_REFINb, GPI[3:0], GPIO[4:0], when acting as inputs. Output specifications refer to signals GPIO[4:0], when acting as outputs. For VDD pin mapping, see GPI and GPIO VDD pin assignments in Pin Information.
2. CLKIN[1:0]/CLKIN[1:0]b used as two single-ended clocks rather than as a differential clock.

Table 39. Power Supply Current [1]

Symbol	Parameter	Conditions	Typical	Maximum	Unit
$I_{DDR}$	$V_{DDR}$ Supply Current	CMOS inputs (per input) [2][3]	11	20	mA
		HCSL inputs (per input pair) [3]	12	15	
		LVDS inputs (per input pair) [2][3]	13	14	
		LVPECL inputs (per input pair) [3][4] $V_{DDR} = 2.5V$ or $3.3V$ ,	13	15	
		CML inputs (per input pair) [3][4] $V_{DDR} = 2.5V$ or $3.3V$ , input termination disabled.	14	16	
		CML inputs (per input pair) [3][4] $V_{DDR} = 2.5V$ or $3.3V$ , input termination enabled.	33	54	
$I_{DDRBIAS}$	Bias Supply Current	Internal DC-bias circuit when enabled for AC-coupled external clock (per input pair) [3]	13	24	mA
$I_{DDX}$	$V_{DDX}$ Supply Current	Crystal oscillator supply	3.5	5	mA
$I_{DDA}$	$V_{DDA}$ Supply Current	$V_{DDA} =$ any valid supply.	142	151	mA
$I_{DDD}$	$V_{DDD}$ Supply Current	$V_{DDD} =$ any valid supply.	69	73	mA
$I_{DDO\_CMOS}$	$V_{DDO}$ Supply Current per output pair, CMOS mode (both OUT[x] and OUT[x]b enabled). [5][6]	$V_{DDO} = 1.8V \pm 5\%$ .	13	20	mA
		$V_{DDO} = 2.5V \pm 5\%$ .	18	24	
		$V_{DDO} = 3.3V \pm 5\%$ .	25	33	
$I_{DDO\_CMOS}$	$V_{DDO}$ Supply Current per output pair, CMOS mode (OUT[x] or OUT[x]b enabled, other output Hi-Z). [5][6]	$V_{DDO} = 1.8V \pm 5\%$ .	8	16	mA
		$V_{DDO} = 2.5 \pm 5\%$ .	11	17	
		$V_{DDO} = 3.3 \pm 5\%$ .	15	23	
$I_{DDO\_LPHCSL}$	$V_{DDO}$ Supply Current per output pair [5][6]	LP-HCSL outputs, 85ohm impedance, fast slew rate, 650MHz. $V_{DDO} =$ any valid supply.	12	19	mA
		LP-HCSL outputs, 85ohm impedance, fast slew rate, 100MHz for PCIe. $V_{DDO} =$ any valid supply.	13	17	
$I_{DDO\_LVDS}$	$V_{DDO}$ Supply Current per output pair, LVDS mode [3][4]	$V_{DDO} =$ any valid supply.	8	17	mA
$I_{DD\_IOD}$	$V_{DDO}$ Divider Supply Current	Portion of $V_{DDO}$ used by IOD	25	28	mA
$I_{DD\_FOD}$	$V_{DDO}$ Divider Supply Current	Portion of $V_{DDO}$ used by FOD	38	51	mA
$I_{DD\_PD}$	Total Power Down Current	Power Down Mode Enabled, $V_{DDs} = 1.8V$	13	16	mA
		Power Down Mode Enabled, $V_{DDs} = 2.5V$	15	23	
		Power Down Mode Enabled, $V_{DDs} = 3.3V$	19	38	

- Current consumption figures represent a worst-case consumption with all functions associated with the particular voltage supply enabled and all outputs running at maximum speed, unless otherwise noted. This information is provided to allow for design of appropriate power supply circuits that will support all possible register-based configurations for the device. To determine actual consumption for the user's device configuration, see [Power Considerations](#). Outputs are not terminated. Values apply to all voltage levels unless noted.
- Voltage of the input signal must be appropriate for the  $V_{DDR}$  voltage supply level when using a DC-coupled connection. For example, when supplying an LVDS input signal that is referenced to a 2.5V supply at its source, the  $V_{DDR}$  supply must also be 2.5V nominal voltage. When using a 3.3V CMOS input signal,  $V_{DDR}$  must be 3.3V
- There are two possible input clock pairs. If both are used, the current for each type must be added together. If the external clock(s) is/are AC-coupled, the internal DC-bias must be enabled and also added to the total  $I_{DDR}$  current.
- LVPECL and CML input clocks are not supported when  $V_{DDR} = 1.8V$ .
- $I_{DDO\_x}$  denotes the current consumed by each output driver and does not include output divider current. These values are measured at maximum output frequency, unless otherwise stated (200MHz for LVCMOS outputs and 650MHz for differential outputs).
- Please refer to the Output Driver and Output Divider  $V_{DDO}$  Pin Assignments Table to determine the allocation of  $I_{DDO\_IOD}$ ,  $I_{DDO\_FOD}$  and  $I_{DDO\_x}$  to each  $V_{DDO}$  pin.

Table 40. I<sup>2</sup>C/SMBus Bus DC Electrical Characteristics [1]

Symbol	Parameter	Conditions	Minimum	Typical	Maximum	Unit
V <sub>IH</sub>	High-level input voltage for SCL_SCLK and SDA_nCS	-	0.7 V <sub>DDD</sub>	-	-	V
V <sub>IL</sub>	Low-level input voltage for SCL_SCLK and SDA_nCS	-	-	-	0.3 V <sub>DDD</sub>	V
V <sub>HYS</sub>	Hysteresis of Schmitt trigger inputs	-	0.05 V <sub>DDD</sub>	-	-	V
V <sub>OL</sub>	Low-level output voltage for SCL_SCLK and SDA_nCS	I <sub>OL</sub> = 4mA	-	-	0.4	V
I <sub>IN</sub>	Input leakage current per pin	-	-10	-	10	μA
C <sub>B</sub>	Capacitive Load for Each Bus Line	-	-	-	400	pF

1. V<sub>OH</sub> is governed by the V<sub>PUP</sub>, the voltage rail to which the pull up resistors are connected.

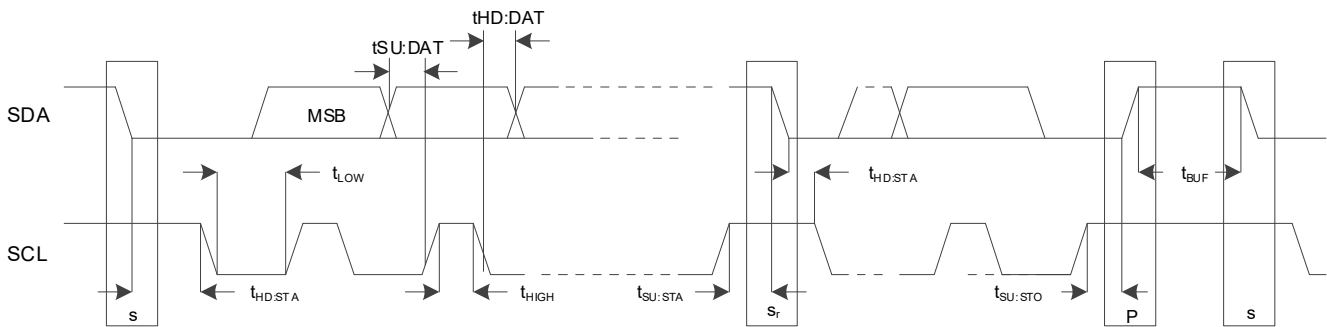

Figure 2. I<sup>2</sup>C/SMBus Target Timing Diagram

Table 41. I<sup>2</sup>C/SMBus Bus AC Electrical Characteristics

Symbol	Parameter	Conditions	100kHz Class Minimum	100kHz Class Maximum	400kHz Class Minimum	400kHz Class Maximum	Unit
f <sub>SMB</sub>	I <sup>2</sup> C/SMBus Operating Frequency [1]	-	10	100	10	400	kHz
t <sub>BUF</sub>	Bus free time between STOP and START Condition	-	4.7	-	1.3	-	μs
t <sub>HD:STA</sub>	Hold time after (REPEATED) START Condition [2]	-	4	-	0.6	-	
t <sub>SU:STA</sub>	REPEATED START Condition setup time	-	4.7	-	0.6	-	
t <sub>SU:STO</sub>	STOP Condition setup time	-	4	-	0.6	-	
t <sub>HD:DAT</sub>	Data hold time target	-	0	-	0	-	
t <sub>SU:DAT</sub>	Data setup time	-	250	-	100	-	ns
t <sub>TIMEOUT</sub>	Detect SCL_SCLK low timeout [3]	-	25	35	25	35	ms
t <sub>TIMEOUT</sub>	Detect SDA_nCS low timeout [4]	-	25	35	25	35	
t <sub>LOW</sub>	Clock low period	-	4.7	-	1.3	-	μs
t <sub>HIGH</sub>	Clock high period [5]	-	4	-	0.6	-	
t <sub>LOW:SEXT</sub>	Cumulative clock low extend time (target device) [6]	-	N/A, the RC210xxB do not extend the clock low.				ms
t <sub>LOW:MEXT</sub>	Cumulative clock low extend time (controller device) [7]	-	N/A, the RC210xxB are not bus controllers.				
t <sub>F</sub>	Clock/Data Fall Time [8]	-	-	300	-	300	ns
t <sub>R</sub>	Clock/Data Rise Time [8]	-	-	1000	-	300	
t <sub>SPIKE</sub>	Noise spike suppression time [9]	-	-	N/A	-	50	

1. A controller should not drive the clock at a frequency below the minimum  $f_{SMB}$ . Further, the operating clock frequency should not be reduced below the minimum value of  $f_{SMB}$  due to periodic clock extending by target devices as defined in Section 5.3.3 of the *SMBus 3.2 Specification*. This limit does not apply to the bus idle condition, and this limit is independent from the  $t_{LOW:SEXT}$  and  $t_{LOW:MEXT}$  limits. For example, if the SMBCLK is high for  $t_{HIGH:MAX}$ , the clock must not be periodically stretched longer than  $1/f_{SMB:MIN} - t_{HIGH:MAX}$ . This requirement does not pertain to a device that extends the SMBCLK low for data processing of a received byte, data buffering and so forth for longer than 100 $\mu$ s in a non-periodic way.
2. A device must internally provide sufficient hold time for the SMBDAT signal (with respect to the  $V_{IH:MIN}$  of the SMBCLK signal) to bridge the undefined region of the falling edge of SMBCLK.
3. Devices participating in a transfer can abort the transfer in progress and release the bus when any single clock low interval exceeds the value of  $t_{TIMEOUT:MIN}$ . After the controller in a transaction detects this condition, it must generate a stop condition within or after the current data byte in the transfer process. Devices that have detected this condition must reset their communication and be able to receive a new START condition no later than  $t_{TIMEOUT:MAX}$ . Typical device examples include the host controller, and embedded controller, and most devices that can control the SMBus. Some simple devices do not contain a clock low drive circuit; this simple kind of device typically may reset its communications port after a start or a stop condition. A timeout condition can only be ensured if the device that is forcing the timeout holds the SMBCLK low for  $t_{TIMEOUT:MAX}$  or longer.
4. The device has the option of detecting a timeout if the SDA\_nCS pin is also low for this time.
5.  $t_{HIGH:MAX}$  provides a simple guaranteed method for controllers to detect bus idle conditions. A controller can assume that the bus is free if it detects that the clock and data signals have been high for greater than  $t_{HIGH:MAX}$ .
6.  $t_{HIGH:MAX}$  provides a simple guaranteed method for controllers to detect bus idle conditions. A controller can assume that the bus is free if it detects that the clock and data signals have been high for greater than  $t_{HIGH:MAX}$ .
7.  $t_{LOW:SEXT}$  is the cumulative time a given target device is allowed to extend the clock cycles in one message from the initial START to the STOP. It is possible that another target device or the controller will also extend the clock causing the combined clock low extend time to be greater than  $t_{LOW:SEXT}$ . Therefore, this parameter is measured with the target device as the sole target of a full-speed controller.
8. The rise and fall time measurement limits are defined as follows:  
 Rise Time Limits: ( $V_{IL:MAX} - 0.15V$ ) to ( $V_{IH:MIN} + 0.15V$ )  
 Fall Time Limits: ( $V_{IH:MIN} + 0.15V$ ) to ( $V_{IL:MAX} - 0.15V$ )
9. Devices must provide a means to reject noise spikes of a duration up to the maximum specified value.

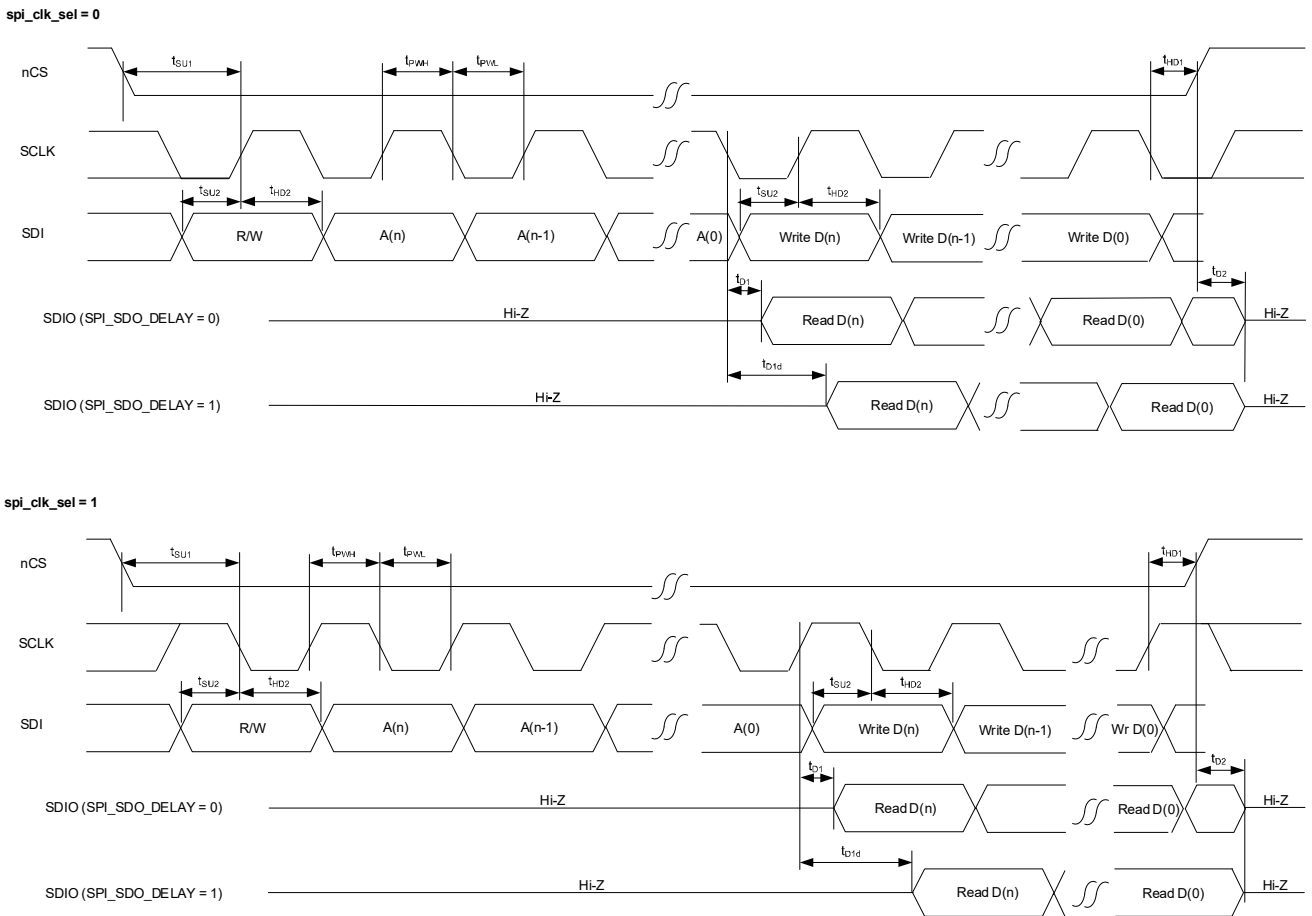

Figure 3. SPI Bus Timing

**Table 42. SPI Target Interface Electrical Characteristics**

Symbol	Parameter	Conditions	Minimum	Typical	Maximum	Unit
f <sub>OP</sub>	Operating frequency	-	0.1	-	20	MHz
t <sub>PWH</sub>	SCLK Pulse Width High	-	-	25	-	ns
t <sub>PWL</sub>	SCLK Pulse Width Low	-	-	25	-	
t <sub>SU1</sub>	nCS Setup Time to SCLK rising or falling edge	-	-	7	-	ns
t <sub>HD1</sub>	nCS Hold Time from SCLK rising or falling edge	-	-	10	-	ns
t <sub>SU2</sub>	SDIO Setup Time to SCLK rising or falling edge	-	-	4	-	ns
t <sub>HD2</sub>	SDIO Hold Time from SCLK rising or falling edge	-	-	1	-	ns
t <sub>D1</sub>	Read Data Valid Time from SCLK rising or falling edge with no data delay added	-	-	6	-	ns
t <sub>D1d</sub>	Read Data Valid Time from SCLK rising or falling edge including half period of SCLK delay added to data timing	[1]	-	6 + half SCLK period	-	ns
t <sub>D2</sub>	SDIO Read Data Hi-Z Time from CS High	[2]	-	10	-	ns

1. Adding the extra half period of delay is a register programming option to emulate read data being clocked out on the opposite edge of the SCLK to the write data.
2. This is the time until the device releases the signal. Rise time to any specific voltage is dependent on pull-up resistor strength and PCB trace loading.

**Table 43. Power Supply Noise Rejection**

Symbol	Parameter	Conditions	Minimum	Typical	Maximum	Unit
PSNR	Power Supply Noise Rejection [1][2][3][4] 1.8V operation	f <sub>NOISE</sub> ≤ 1MHz, VDDO[0:6] [5]	-146	-112	-	dBc
		f <sub>NOISE</sub> ≤ 1MHz	-76	-69	-	
		f <sub>NOISE</sub> ≤ 100kHz	-138	-135	-	
		f <sub>NOISE</sub> ≤ 100kHz	-97	-85	-	
		100kHz ≤ f <sub>NOISE</sub> ≤ 500kHz	-140	-139	-	
		100kHz ≤ f <sub>NOISE</sub> ≤ 500kHz	-138	-105	-	
		500kHz ≤ f <sub>NOISE</sub> ≤ 1MHz	-144	-143	-	
		500kHz ≤ f <sub>NOISE</sub> ≤ 1MHz	-93	-90	-	
PSNR	Power Supply Noise Rejection [1][3][4][6] 2.5V or 3.3V operation	f <sub>NOISE</sub> ≤ 1MHz, VDDO[0:6] [5]	-146	-112	-	dBc
		f <sub>NOISE</sub> ≤ 1MHz	-76	-69	-	
		f <sub>NOISE</sub> ≤ 100kHz	-138	-135	-	
		f <sub>NOISE</sub> ≤ 100kHz	-94	-85	-	
		100kHz ≤ f <sub>NOISE</sub> ≤ 500kHz	-140	-139	-	
		100kHz ≤ f <sub>NOISE</sub> ≤ 500kHz	-138	-105	-	
		500kHz ≤ f <sub>NOISE</sub> ≤ 1MHz	-144	-143	-	
		500kHz ≤ f <sub>NOISE</sub> ≤ 1MHz	-93	-90	-	

1. Electrical parameters are guaranteed over the specified ambient operating temperature range, which is established when the device is mounted in a test socket with maintained transverse airflow greater than 500fpm. The device will meet specifications after thermal equilibrium has been reached under these conditions.
2. VDDX = VDDR = VDDR2 = VDDA = VDD[0:6] = 1.8V ±5%, VSS = 0V, TA = -40°C to 85°C.
3. 50mV peak-to-peak sine wave applied injected on indicated power supply pin(s).
4. Noise spur amplitude measured relative to 156.25MHz carrier frequency.
5. Excluding VDDOx of the output being measured.
6. VDDX = VDDR = VDDR2 = VDDA = VDD[0:6] = 2.5V or 3.3V ±5%, VSS = 0V, TA = -40°C to 85°C.

## 3. Functional Description

The RC210xxB is a small-form factor, fully integrated, low-power, high performance frequency synthesizer providing excellent phase jitter on reference clocks for PCI express and Ethernet, while covering a wide range of output frequencies up to 650MHz. It can simultaneously provide low phase jitter non-spreading clocks for Ethernet and storage applications, while providing spread-spectrum PCIe Gen6 clocks.

The following sections provide an overview of the RC210xxB.

### 3.1 Power-Up, Configuration, and Serial Interfaces

The RC210xxB can be powered up and configured in three ways:

1. From 1 of 27 internal non-volatile memory using OTP user configurations (UserCfgs)
2. From its target serial interface
3. From an external I2C EEPROM

The RC210xxB supports three target serial interfaces (I2C, SPI, and SMBUS), and one serial host interface (I2C). These interfaces share the same pins, so only one is available at a time.

### 3.2 Input Clocks

The RC210xxB supports one crystal/reference input and up to two differential or four single-ended clock inputs.

#### 3.2.1 Crystal/Reference Input

The crystal input supports crystal frequencies of 8MHz to 80MHz. It has programmable internal load capacitors to support crystals with CL = 6pF to 12pF. Internal crystal variants of RC210xxB support a trim value in OTP that can be set during ATE to compensate for initial frequency offset of the internal crystal.

The crystal input may be over-driven with differential or single-ended inputs with proper external terminations. It also supports being over-driven with a clipped sine-wave TCXO with a 0.8V<sub>PP</sub> signal.

The supported frequency range is same as reference clock inputs: 1kHz to 650MHz in differential mode, and 1kHz to 200MHz in single-ended mode.

An available LOS monitor detects the loss of signal on crystal input.

#### 3.2.2 Clock Inputs

There are two differential clock inputs that support LVDS, HCSL, or single-ended CMOS logic levels without external terminations. LVPECL or CML clock inputs may be supported with external terminations and/or AC coupling. Internal terminations are available for both HCSL and LVDS logic levels. Additionally, HCSL input terminations support both 100ohm and 85ohm operating environments.

If set to single-ended type, the differential inputs turn into two single-ended inputs. CLKIN0 drives clkin0 internally, CLKIN0b drives clkin1 internally, CLKIN1 drives clkin2 internally, and CLKIN1b drives clkin3 internally. If set to differential type, CLKIN0/CLKIN0b pair drives clkin0 while CLKIN1/CLKIN1b pair drives clkin2. Internal biasing is available for AC-coupled applications. The two clock inputs can be left floating when unused. An available LOS monitor detects the loss of signal on crystal input.

### 3.3 Clock Input Monitor

The APLL input is monitored for Loss of Signal (LOS).

The LOS monitor detects missing edges over a window of several reference clock periods. For the best accuracy, it is recommended to program the window to be equal to at least 8 times that of the measuring clock period.

## 3.4 APLL

The APLL is fractional LC-VCO based PLL with an operating range from 9.5GHz to 10.7GHz. Any of the available input clocks can be selected to drive the APLL, and the input clock can be frequency doubled for increased performance. The APLL is temperature compensated for the utmost frequency stability. For synchronous, deterministic requirements, the APLL also supports ZDB mode where CLKIN0 is used for the feedback input.

### 3.4.1 APLL Lock Detector

The APLL lock detector indicates whether the APLL is locked to a functioning crystal or reference input by monitoring the phase errors. Lock status can be sent on to a GPIO pin or in the register map.

## 3.5 Output Dividers

The RC210xxB provides four integer and three fractional output dividers.

### 3.5.1 Integer Output Dividers

All four Integer Output Dividers (IOD) are identical. They use a 25-bit divider to provide output frequencies of 1kHz to 650MHz from the VCO clock. Changing IOD values results in an immediate change to the new frequency. Glitch-less squelch and release of the IOD clock is supported. When enabled, this mimics a gapped clock behavior when an IOD frequency is changed.

### 3.5.2 Fractional Output Dividers

There are three Fractional Output Dividers (FOD). Each FOD can divide down the VCO clock to provide frequencies from 1kHz to 650MHz. Each FOD is implemented in two stages. The first stage is an 8-bit fractional divider with Digital Control Delay (DCD) correction. The DCD FOD allows a divide down of the VCO clock to 30MHz to 650MHz. A 17-bit second-stage integer divider with minimum divide ratio of 4 and a maximum ratio of  $2^{17}-1$  allows output frequencies lower than 30MHz. For output frequencies above 30MHz, this second-stage divider may be bypassed.

#### 3.5.2.1 Spread-Spectrum Clocking

FOD0 and FOD1 support Spread-Spectrum Clocking (SSC).

When SSC is enabled, the spread spectrum engine modulates the FOD divider ratio with a triangular modulation pattern. The modulation can be programmed for either down-spread or center-spread. The SSC modulation frequency can be programmed to a value between 30kHz to 63kHz. The SSC amplitude can be programmed in 0.05% steps to -1.5% for down spread, or  $\pm 1.5\%$  for center spread. When turning off SSC, the current modulation cycle completes, returning the output to the non-spreading frequency before the SSC stops.

#### 3.5.2.2 Sync and Phase Adjustment

Each FOD can adjust its output clock phase with a step size of 1/4 VCO period up to about  $\pm 20$ ns. The adjustment can be of either positive or negative directions.

IOD phase adjustment is same as FOD phase adjustment but with a step size of one VCO period.

## 3.6 Clock Outputs

The RC210xxB supports up to 12 differential or 24 single-ended clock outputs or any combination of differential and single-ended clock outputs. Every differential clock output can be programmed as two single-ended clock outputs.

### 3.6.1 Output Types

The RC210xxB outputs drive HCSL inputs (such as those used in PCIe applications) directly. They use Low-Power HCSL (LP-HCSL) driver technology to eliminate external termination resistors. The LP-HCSL outputs can be set to 85ohm or 100ohm differential output impedance. The LP-HCSL outputs have selectable output swing and slew rate settings.

The RC210xxB outputs may also be set to LVDS. LVDS outputs require only a 100ohm resistor between the true and complement inputs of the receiver clock input. LVDS outputs have selectable amplitude. Both LVDS and LP-HCSL outputs provide LVPECL and CML-compatible output swing levels by using external AC coupling.

If set to single-ended mode, the output pair can drive either pin or both pins. If both pins are enabled, they can be in phase, or inverted phase. The single-ended outputs support CMOS swings of 1.8V, 2.5V, or 3.3V as determined by their VDDO voltage.

### 3.6.2 Output Banks

The RC210xxB maps the internal and external frequency sources to output banks, that can be programmed in register `out_bank_src`, according to [Table 44](#). There are up to 12 clock outputs arranged in seven output banks. Each bank sits on its own VDDO (each VDDO also supplies an IOD or FOD according to [Table 45](#)).

**Table 44. Output Bank Source Mapping**

output_bank_src	Bank 0	Bank 1	Bank 2	Bank 3	Bank 4	Bank 5	Bank 6
	OUT0	OUT1	OUT[2:3]	OUT[4:7]	OUT[8:9]	OUT10	OUT11
0x0	IOD0		N/A		CLKIN1		
0x1	IOD1			N/A		XIN_REFIN	N/A
0x2	N/A				IOD2		
0x3	N/A					IOD3	
0x4	FOD0				N/A		
0x5	FOD1						
0x6	N/A			FOD2			
0x7	N/A				CLKIN0		

**Table 45. VDD Pin Assignments for Outputs, Integer Output Dividers, and Fractional Output Dividers**

VDDO0	VDDO1	VDDO2	VDDO3	VDDO4	VDDO5	VDDO6	VDDX	VDDR	VDDD	VDDA
IOD0, OUT0	IOD1, OUT1	FOD0, OUT[2:3]	FOD1, OUT[4:7]	FOD2, OUT[8:9]	IOD2, OUT10	IOD3, OUT11	XO, XIN_REFIN, XOUT_REFIN b	GPI[3:0]	SCL_SCLK, SDA_nCS, GPIO[4:0]	PLL

## 4. Application Information

### 4.1 Recommendations for Unused Pins

#### 4.1.1 XIN\_REFIN/XOUT\_REFINB

If used as a crystal input, both XIN\_REFIN and XOUT\_REFINB must be connected to a crystal. If using these pins as XIN\_REFIN/XOUT\_REFINB, see [Overdriving the XTAL Interface](#) for important information. If XIN\_REFIN and XOUT\_REFINB are unused, the pins should be left floating with no trace attached.

#### 4.1.2 CLKIN/CLKINb [1:0] Inputs

For applications that do not require the use of reference clock inputs, both CLKIN and CLKINb should be left floating. If the CLKIN/CLKINb inputs are connected but not used by the device, Renesas recommends that CLKIN and CLKINb be connected to static signals, not active signals.

#### 4.1.3 GPIO/GPI Pins

LVC MOS control pins have selectable internal pull-ups and/or pull-downs and can be left floating. Additional resistance is not required but can be added for additional protection. If additional resistance is used, it is recommended to enable the internal pull-down and add an external 10kΩ resistor to GND.

#### 4.1.4 LVC MOS Outputs

Any LVC MOS output may be left floating if unused. There should be no trace attached. The mode of the output buffer should be set to high impedance state to avoid unnecessary noise generation.

#### 4.1.5 Differential Outputs

All unused differential outputs may be left floating. There should be no trace attached. Both sides of the differential output pair should be treated the same, either left floating or terminated.

### 4.2 CLKIN/CLKINb Clock Inputs Interface

The RC210xxB provides a programmable input buffer for reference clock inputs, as shown in [Figure 4](#). This programmable buffer supports most standard signaling protocols with no need for external termination components at the receiver end of the transmission line.

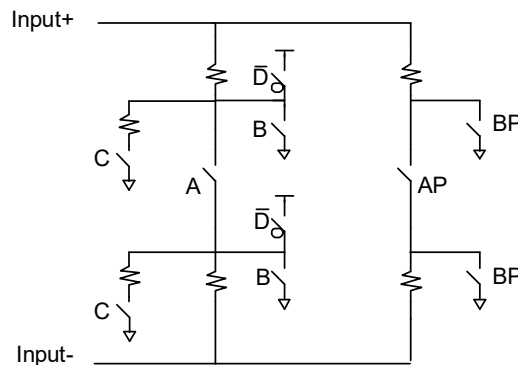

Figure 4. Programmable Input Buffer Logical Diagram

By making appropriate register selections, the switches labeled in [Figure 4](#) can be closed as shown in [Table 46](#) to support the indicated protocols. With the switches closed as indicated, the input buffer will operate as shown in [Figure 5](#) for the various input reference signal protocols. Note that HCSL is used in both 100ohm and 85ohm transmission line environments and this input buffer supports both with no external terminations required.

Table 46. Input Buffer Programming Options for Specific Signaling Protocols

Input Signaling Protocol	Switches Closed	V <sub>DDR</sub> Voltage Required
2.5V LVPECL	A, C	2.5V
3.3V LVPECL	A, C	3.3V
LVDS (85 ohms)	A, AP	1.8V / 2.5V / 3.3V
LVDS (100 ohms)	A	1.8V / 2.5V / 3.3V
1.8V LVCMOS	-	1.8V
2.5V LVCMOS	-	2.5V
3.3V LVCMOS	-	3.3V
CML	D	3.3V
HCSL (42.5 ohms)	B, BP	1.8V / 2.5V / 3.3V
HCSL (42 ohms)	B	1.8V / 2.5V / 3.3V
Externally AC-coupled <sup>[1]</sup>	-	1.8V / 2.5V / 3.3V

1. In this mode of operation, AC-coupling capacitors must be used to isolate the voltage level of the transmitter from the receiver. The signal must be properly terminated on the transmitter side of the AC-coupling capacitors. Bias terminations are needed between the AC-coupling capacitors and the RC210xxB.

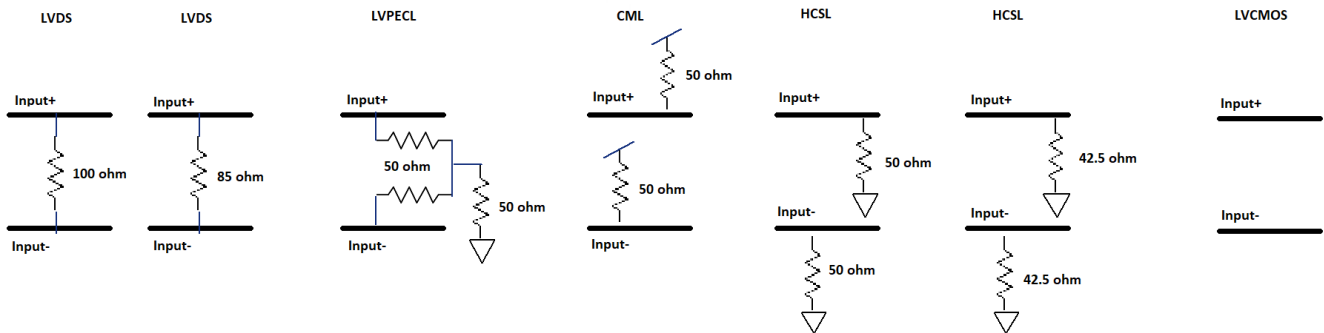

Figure 5. Input Buffer Behavior by Protocol

### 4.3 Overdriving the XTAL Interface

#### 4.3.1 XTAL Interface Set to Input Buffer Mode

The RC210xxB has two bits to disconnect the internal XO and enable input buffer mode on the XIN\_REFIN/XOUT\_REFINb pins. First, setting `sel_ib_xo = 0`, disconnects the internal XO. Next, setting `xo_ib_cmos_sel = 1` enables the LVCMOS input clock path. Setting these two bits as indicated removes any AC-coupling or input voltage requirements for overdriving the XTAL interface. Note that the maximum input swing is still governed by the VDDX supply rail. Once set to Input Buffer Mode, the input can be directly driven with a single-ended or differential oscillator. There is no internal termination capability when using the XTAL interface in input buffer mode. Other than this lack of internal terminations, the input buffer mode has all capabilities of the CLKIN/CLKINb interfaces.

#### 4.3.2 XTAL Interface in XO Mode, Input Buffer Mode Not Selected

If the two bits mentioned above are not set as indicated, then there is a limitation of 1.2V on the XIN\_REFIN/XOUT\_REFINb pins. Input buffer mode is preferred as described in section 4.3.1.

The XIN\_REFIN input can be overdriven by an LVCMOS driver or by one side of a differential driver through an AC coupling capacitor. The XOUT pin can be left floating. The amplitude of the input signal should be between 500mV and 1.2V, and the slew rate must be  $\geq 0.2V/ns$ . For 1.2V LVCMOS, inputs can be DC-coupled into the device as shown in Figure 6. For LVCMOS drivers with > 1.2V swing, the amplitude must be reduced from full

swing to at least 1.2V in order to prevent signal interference with the power rail. The sum of the driver output impedance and  $R_s$  must equal the transmission line impedance to prevent overshoot and undershoot.

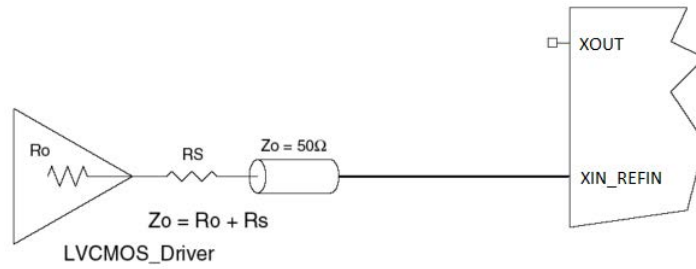

Figure 6. 1.2V LVCMOS Driver to XTAL Input Interface

Figure 7 shows an example of the interface diagram for a high-speed 3.3V LVCMOS driver. This configuration requires that the sum of the output impedance of the driver ( $R_o$ ) and the series resistance ( $R_s$ ) equal the transmission line impedance. This can be done in one of two ways. First,  $R_1$  and  $R_2$  in parallel should equal the transmission line impedance. We also need to scale the 3.3V LVCMOS swing to 1.2V (~1/3 of the swing). This yields  $R_1 = 2 \times R_2$  while  $R_1 \parallel R_2 = 50\Omega$ . Solving for a 50Ω ohm system gives  $R_1 = 150\Omega$  and  $R_2 = 75\Omega$ . The values of the resistors can be increased to reduce the loading for a slower and weaker LVCMOS driver. Different scaling factors are required for 2.5V and 1.8V LVCMOS drivers.

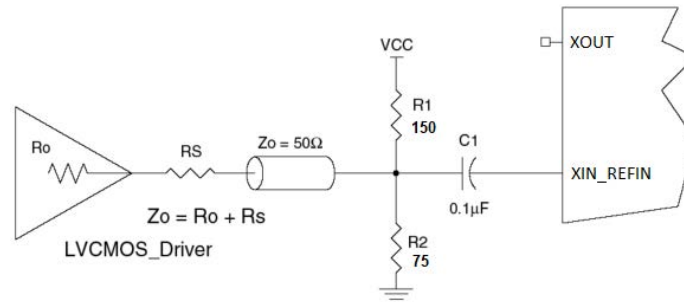

Figure 7. LVCMOS Driver to XTAL Input Interface

Figure 8 shows an example of the interface diagram for an LVPECL driver. This is a standard LVPECL termination with one side of the driver feeding the XIN\_REFIN input. Renesas recommends that all components in the schematics be placed in the layout. Though some components may not be used by the application, they can be used for debugging purposes.

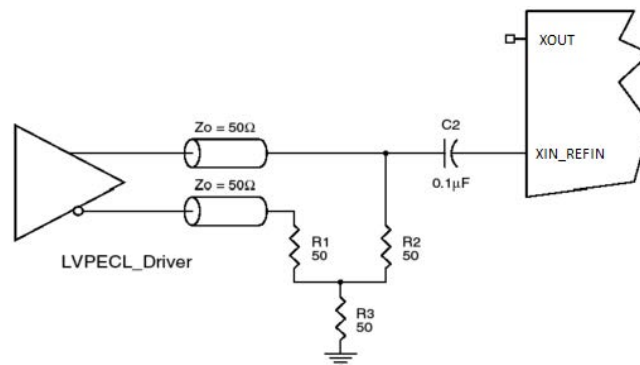

Figure 8. LVPECL Driver to XTAL Input Interface

## 4.4 Differential Output Terminations

### 4.4.1 Direct-Coupled LP-HCSL Termination

For the LP-HCSL differential protocol, the following termination scheme is recommended (see Figure 9). The RC210xxB supports internal source terminations (see Figure 9) for 85 ohm or 100 ohm differential transmission lines. No external components are needed.

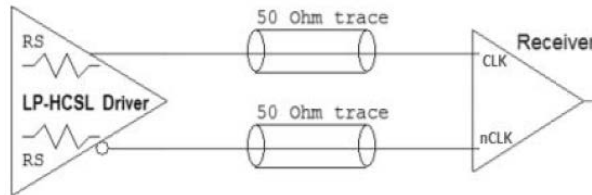

Figure 9. Standard HCSL Termination

### 4.4.2 Direct-Coupled LVDS Termination

For LVDS differential protocol, the following termination scheme is recommended (see Figure 10). The recommended value for the termination impedance ( $Z_T$ ) is between  $90\Omega$  and  $132\Omega$ . The actual value should be selected to match the differential impedance ( $Z_0$ ) of the transmission line. A typical point-to-point LVDS design uses a  $100\Omega$  parallel resistor at the receiver in a  $100\Omega$  differential transmission-line environment. In order to avoid any transmission-line reflection issues, any external components should be surface-mounted and must be placed as close to the receiver as possible.

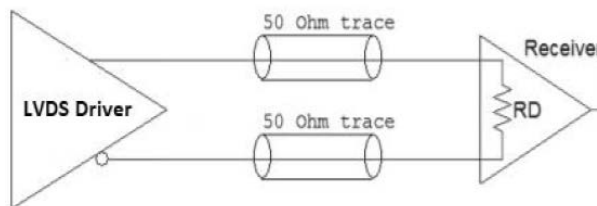

Figure 10. Standard LVDS Termination

### 4.4.3 AC-Coupled Differential Terminations for Other Protocols

Alternate differential protocols including LVPECL, CML and SSTL can be supported with AC-coupled LP-HCSL outputs. Figure 11 shows a typical AC-coupled termination scheme for a  $100\Omega$  differential transmission-line environment. The RC210xxB supports a differential swing of 1.6V or 1.8V in LP-HCSL mode.

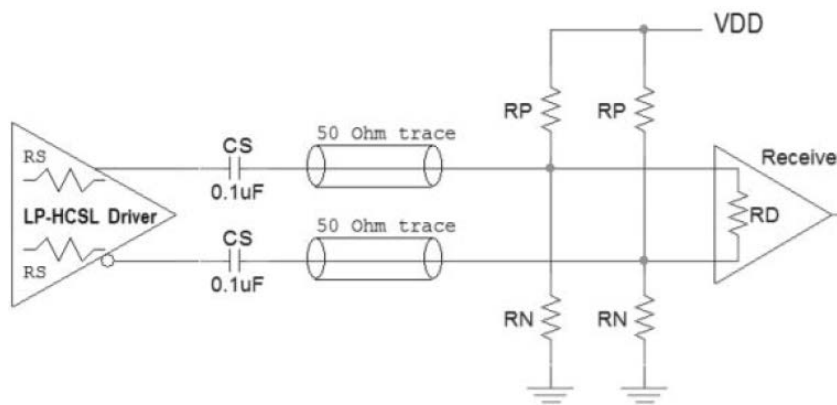

Figure 11. AC-Coupling Termination

No terminations are needed between the RC210xxB and the AC-coupling capacitors. The resistors on the receiver side of the AC-coupling capacitors provide an appropriate voltage bias for the particular receiver. Finally,

a 100Ω resistor across the differential pair (located near the receiver) attenuates reflections that may corrupt the clock signal integrity.

Often, receivers used with a high-performance device like the RC210xxB are equipped with internal terminations, voltage biasing, and even AC-coupling. Please consult your particular the receiver specification to determine if any or all of the indicated external components in Figure 11 are needed.

Refer to *Driving LVPECL, LVDS, CML, and SSTL Logic with Renesas' "Universal" Low-Power HCSL Outputs* (AN-891) on the RC210xxB product page for additional information on both re-biasing and amplitude attenuation.

If a smaller differential swing is desired as a starting point, refer to "LVDS Termination" in *Quick Guide - Output Terminations* (AN-953) located on the RC210xxB product page.

Please contact Renesas for additional support, if necessary.

## 4.5 Crystal Recommendations

For the latest vendor / frequency recommendations, please contact Renesas.

### 4.5.1 Choosing Crystals

A crystal manufacturer will calibrate its crystals to the nominal frequency with a certain load capacitance value. When the oscillator load capacitance matches the crystal load capacitance, the oscillation frequency will be accurate. When the oscillator load capacitance is lower than the crystal load capacitance, the oscillation frequency will be higher than nominal, and vice versa. Therefore, for an accurate oscillation frequency, ensure to match the oscillator load capacitance with the crystal load capacitance.

### 4.5.2 Tuning the Crystal Load Capacitor

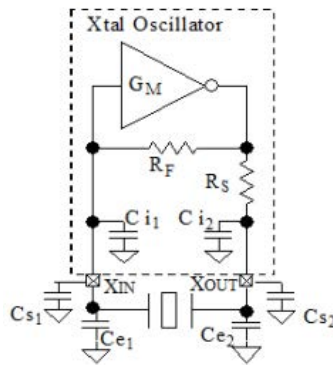

Figure 12. Crystal Load Capacity

Ci1 and Ci2 are on-chip capacitors that are programmable.

Cs is stray capacitance in the PCB and Ce is external capacitors for frequency fine tuning or for achieving load capacitance values beyond the range of the on-chip programmability.

The value of each capacitor is composed of a fixed capacitance amount plus a variable capacitance amount set with the XTAL[5:0] register. Ci1 and Ci2 are commonly programmed to be the same value. Adjustment of the crystal tuning capacitors allows maximum flexibility to accommodate crystals from various manufacturers.

The range of tuning capacitor values available are in accordance with the following table. Ci1/Ci2 starts at 0pF with setting 0x00, and can be increased up to 26.8pF with setting 0x3F. The step per bit is 0.42pF.

Table 47. XTAL[5:0] Tuning Capacitor

Parameter	Bits	Step (pF)	Minimum (pF)	Maximum (pF)
XTAL	6	0.42	0	26.8

The following equation can be written for this capacitance:

$$CXIN = Ci1 + Cs1 + Ce1$$

$$CXOUT = Ci2 + Cs2 + Ce2$$

The final load capacitance of the crystal:

$$C_L = CXIN \times CXOUT / (CXIN + CXOUT)$$

It is recommended to set the capacitors to the same value at each crystal pin, meaning:  $CXIN = CXOUT$ .

*Example 1:* The crystal load capacitance is specified as 8pF and the stray capacitance at each crystal pin is  $Cs = 1.5pF$  and package stray capacitance is  $Ce = 7pF$ .

Assuming equal capacitance value at XIN and XOUT = 6.72pF. The equation follows:

$$C_L = (6.72pF + 7.5pF + 1.5pF)/2 = 7.86pF$$

$$XTAL[5:0] = 10000$$

## 4.6 External I<sup>2</sup>C Serial EEPROM Recommendations

An external I<sup>2</sup>C EEPROM can be used to store configuration data, please contact Renesas for specific recommendations. A specific configuration code is required for the devices to access an external I<sup>2</sup>C serial EEPROM at power up. See the ordering information.

## 4.7 Power Considerations

The electrical characteristics tables provide current consumption values for various blocks and output configurations, and can be used to estimate total current consumption for a particular design. The Renesas IC Toolbox, available on the Renesas website, can also be used to estimate current consumption. A quick note on terms used in this section: “power rail” refers to the power connection to a particular VDD pin. This means that different VDD pins might be connected to the same voltage, yet may also be connected to different power rails. We will use “power rail” when discussing power sequencing considerations.

### 4.7.1 Power Sequencing Considerations

The RC210xxB has no specific power sequencing requirements. The design software may be used to disconnect unused power supply pins in the silicon, which then allows the user to leave these unused supply pins unconnected. These unused pins are then removed from power sequencing considerations.

The RC210xxB also has two GPIO functions (PWRGD/PWRDN# or PWRGD/RESTART#) which give the user more control over power up timing in applications environments such as data centers. These environments often need to hold clocks in reset until the devices receiving the clocks have completed their power-up housekeeping and are ready to receive clocks. We discuss operation without this GPIO function first, followed by a discussion with this GPIO function.

#### 4.7.1.1 Power-Up Operation without PWRGD/PWRDN# or PWRGD/RESTART# Function

When PWRGD/PWRDN# or PWRGD/RESTART# is not used, the RC210xxB outputs are gated by the last VDD pin to become valid. See [Table 18](#) for details.

#### 4.7.1.2 Power-Up Using PWRGD/PWRDN# or PWRGD/RESTART#

Using the PWRGD/PWRDN# or PWRGD/RESTART# GPIO configuration gives the user more control over power-up behavior. Holding the pin low, pauses the RC210xxB start-up sequence until the pin is asserted high. This pin should be held low from the very beginning of the power up sequence. The pin function is defined as follows:

- PWRGD means Power is Good (active high). Asserting PWRGD/PWRDN# or PWRGD/RESTART# high after all power rails are valid, tells the RC210xxB that power is good, power up completely and begin operation. The *first* high assertion of PWRGD/PWRDN# loads a new configuration into the device (selected by external pins if there are multiple configurations). Subsequent high assertions of PWRGD/PWRDN# return to the previously loaded configuration.

- PWRDN# means enter Power Down (active low). Asserting PWRGD/PWRDN# low puts (or keeps) the RC210xxB in a low power state, turning off as much internal logic as possible (including the APLL) to save the most power while keeping the power rails active. Returning from PWRDN# by asserting PWRGD/PWRDN# high resumes the previous operating state.
- RESTART# means Restart (active low). Asserting PWRGD/RESTART# low resets the RC210xxB and prepares it for a complete restart of entire power up sequence without having to remove the power supplies. Returning from RESTART# by asserting the PWRGD/RESTART# pin high loads a new configuration, which may or may not be different from the one used before RESTART# asserted low.

Figure 13 shows use of a PWRGD/PWRDN# or PWRGD/RESTART# input to hold the entire RC210xxB until all power supply rails reach 1.62V. The PWRGD/PWRDN# pin must be held low for at least  $t_{HOLD}$  after the last VDDO pin reaches 1.62V. It may be held longer. Using the PWRGD/PWRDN# or PWRGD/RESTART# GPIO function isolates the RC210xxB from changes to power supply sequencing that may be induced by changes to other devices in the system. A configuration can contain PWRGD/PWRDN# or PWRGD/RESTART#, not both. If the power down state is not used, PWRGD/RESTART# is the preferred configuration, since it allows more flexibility with GPI/GPIO assignment.

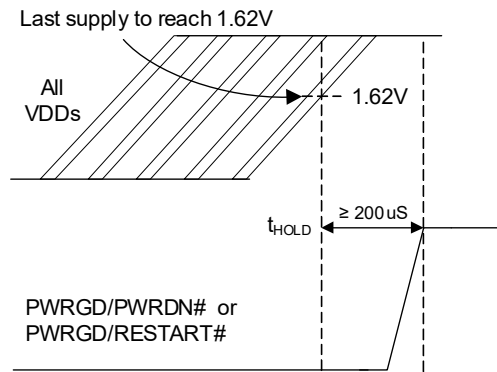

Figure 13. Power Supply Sequencing Recommendations – Power-Up Using PWRGD/PWRDN# or POR#

## 5. Thermal Information

### 5.1 VFQFPN ePad Thermal Release Path

In order to maximize both the removal of heat from the package and the electrical performance, a land pattern must be incorporated on the Printed Circuit Board (PCB) within the footprint of the package corresponding to the exposed metal pad or exposed heat slug on the package, as shown in Figure 14. The solderable area on the PCB, as defined by the solder mask, should be at least the same size/shape as the exposed pad/slug area on the package to maximize the thermal/electrical performance. Sufficient clearance should be designed on the PCB between the outer edges of the land pattern and the inner edges of pad pattern for the leads to avoid any shorts.

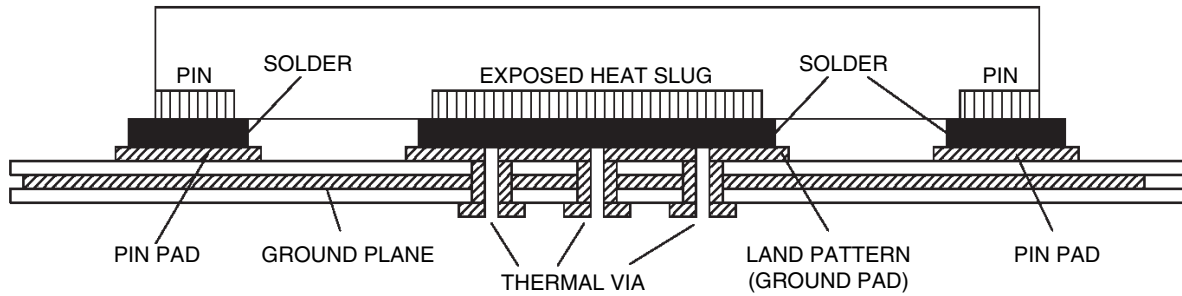

Figure 14. P.C. Assembly for Exposed Pad Thermal Release Path – Side View

While the land pattern on the PCB provides a means of heat transfer and electrical grounding from the package to the board through a solder joint, thermal vias are necessary to effectively conduct from the surface of the PCB to the ground plane(s). The land pattern must be connected to ground through these vias. The vias act as “heat pipes.” The number of vias (i.e., “heat pipes”) are application specific and dependent on the package power dissipation as well as electrical conductivity requirements. Thus, thermal and electrical analysis and/or testing are recommended to determine the minimum number needed.

Maximum thermal and electrical performance is achieved when an array of vias is incorporated in the land pattern. It is recommended to use as many vias connected to ground as possible. It is also recommended that the via diameter should be 12 to 13mils (0.30 to 0.33 mm) with 1oz copper via barrel plating. This is desirable to avoid any solder wicking inside the via during the soldering process which may result in voids in solder between the exposed pad/slug and the thermal land. Precautions should be taken to eliminate any solder voids between the exposed heat slug and the land pattern. Note: These recommendations are to be used as a guideline only. For further information, please refer to the Application Note on the Surface Mount Assembly of Amkor’s Thermally/Electrically Enhance Lead frame Base Package, Amkor Technology.

### 5.2 Thermal Characteristics

Table 48. Thermal Characteristics (48-pin with External Crystal) [1]

Symbol	Parameter	Value	Unit
$\theta_{JC}$	Theta $J_C$ . Junction to Device Case Thermal Coefficient [2]	20.1	°C/W
$\theta_{JB}$	Theta $J_B$ . Junction to Board Thermal Coefficient [2]	1.9	
$\theta_{JA}$	Junction to Ambient Air Thermal Coefficient (still air)	25.8	
	Junction to Ambient Air Thermal Coefficient 1 m/s air flow	21.5	
	Junction to Ambient Air Thermal Coefficient 2 m/s air flow	18.8	
-	Junction to Ambient Air Thermal Coefficient 3 m/s air flow	17.9	
-	Moisture Sensitivity Rating (Per J-STD-020)	3	N/A

1. JEDEC Standard PCB (101.6 x 114.5 x 1.6 mm) with two ground and two voltage planes.
2. Assumes ePad is connected to a ground plane using a grid of 25 thermal vias.

Table 49. Thermal Characteristics (40-pin with External Crystal) [1]

Symbol	Parameter	Value	Unit
$\theta_{JC}$	Theta $J_C$ . Junction to Device Case Thermal Coefficient [2]	35.7	°C/W
$\theta_{JB}$	Theta $J_B$ . Junction to Board Thermal Coefficient [2]	1.9	
$\theta_{JA}$	Junction to Ambient Air Thermal Coefficient (still air)	28.9	
	Junction to Ambient Air Thermal Coefficient 1 m/s air flow	25.6	
	Junction to Ambient Air Thermal Coefficient 2 m/s air flow	23	
-	Moisture Sensitivity Rating (Per J-STD-020)	3	N/A

1. JEDEC Standard PCB (101.6 × 114.5 × 1.6 mm) with two ground and two voltage planes.
2. Assumes ePad is connected to a ground plane using a grid of 16 thermal vias.

Table 50. Thermal Characteristics (48-pin with Internal Crystal) [1]

Symbol	Parameter	Value	Unit
$\theta_{JC}$	Theta $J_C$ . Junction to Device Case Thermal Coefficient [2]	24.5	°C/W
$\theta_{JB}$	Theta $J_B$ . Junction to Board Thermal Coefficient [2]	15	
$\theta_{JA}$	Junction to Ambient Air Thermal Coefficient (still air)	37.3	
	Junction to Ambient Air Thermal Coefficient 1 m/s air flow	35	
	Junction to Ambient Air Thermal Coefficient 2 m/s air flow	33	
-	Moisture Sensitivity Rating (Per J-STD-020)	3	N/A

1. JEDEC Standard PCB (101.6 × 114.5 × 1.6 mm) with two ground and two voltage planes.
2. Assumes ePad is connected to a ground plane using a grid of 25 thermal vias.

Table 51. Thermal Characteristics (40-pin with Internal Crystal) [1]

Symbol	Parameter	Value	Unit
$\theta_{JC}$	Theta $J_C$ . Junction to Device Case Thermal Coefficient [2]	35	°C/W
$\theta_{JB}$	Theta $J_B$ . Junction to Board Thermal Coefficient [2]	52.4	
$\theta_{JA}$	Junction to Ambient Air Thermal Coefficient (still air)	70.7	
	Junction to Ambient Air Thermal Coefficient 1 m/s air flow	65.9	
	Junction to Ambient Air Thermal Coefficient 2 m/s air flow	62.5	
-	Moisture Sensitivity Rating (Per J-STD-020)	3	N/A

1. JEDEC Standard PCB (101.6 × 114.5 × 1.6 mm) with two ground and two voltage planes.
2. Assumes ePad is connected to a ground plane using a grid of 16 thermal vias.

Table 52. Thermal Characteristics (32-pin with Internal Crystal) [1]

Symbol	Parameter	Value	Unit
$\theta_{JC}$	Theta J <sub>C</sub> . Junction to Device Case Thermal Coefficient [2]	61.2	°C/W
$\theta_{JB}$	Theta J <sub>B</sub> . Junction to Board Thermal Coefficient [2]	7.4	
$\theta_{JA}$	Junction to Ambient Air Thermal Coefficient (still air)	40.3	
	Junction to Ambient Air Thermal Coefficient 1 m/s air flow	37.4	
	Junction to Ambient Air Thermal Coefficient 2 m/s air flow	34.8	
	Junction to Ambient Air Thermal Coefficient 3 m/s air flow	33	
-	Moisture Sensitivity Rating (Per J-STD-020)	3	N/A

1. JEDEC Standard PCB (101.6 x 114.5 x 1.6 mm) with two ground and two voltage planes.
2. Assumes ePad is connected to a ground plane using a grid of 4 thermal vias.

## 6. Package Outline Drawings

The package outline drawings are located at the end of this document and are accessible from the Renesas website. The package information is the most current data available and is subject to change without revision of this document.

## 7. Marking Diagrams

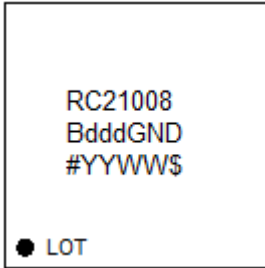

RC21008Bddd

- Lines 1 and 2: part number.
  - “ddd” indicates preprogrammed device custom configuration dash code.
- Line 3:
  - “#” indicates the stepping number.
  - “YYWW” indicates the last two digits of the year and work week the part was assembled.
  - “\$” indicates the mark code.

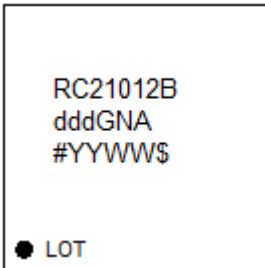

RC21012Bddd

- Lines 1 and 2: part number.
  - “ddd” indicates preprogrammed device custom configuration dash code.
- Line 3:
  - “#” indicates the stepping number.
  - “YYWW” indicates the last two digits of the year and work week the part was assembled.
  - “\$” indicates the mark code.

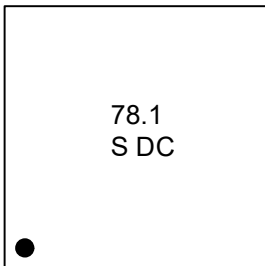

RC21005BQdd

Due to package construction, the marking of the RC21005BQdd is that of the integrated crystal. The “dd” dash-code is encoded in a unique digital register “marking” that is documented in the addendum. The crystal marking is defined as follows:

- Line 1: Abbreviated notation of the 78.125MHz crystal frequency.
- Line 2: “S” is crystal vendor. “DC” is the date code which is encoded as follows:

Last Digit of Year	D (Year Code)	Month	C (Month Code)
1	A	1	A
2	B	2	B
3	C	3	C
4	D	4	D
5	E	5	E
6	F	6	F
7	G	7	G
8	H	8	H
9	J	9	J
0	K	10	K
-	-	11	L
-	-	12	M



RC21008BQdd

- Lines 1 and 2: part number.
  - “dd” indicates preprogrammed device custom configuration dash code.
- Line 3:
  - “#” indicates the stepping number.
  - “YWW” indicates the last digit of the year and work week the part was assembled.
  - “\*\*” indicates the lot sequential number
  - “\$” indicates the mark code.

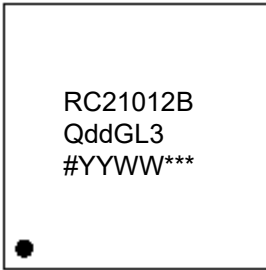

RC21012BQdd

- Lines 1 and 2: part number.
  - “dd” indicates preprogrammed device custom configuration dash code.
- Line 3:
  - “#” indicates the stepping number.
  - “YYWW” indicates the last two digits of the year and work week the part was assembled.
  - “\*\*\*” indicates the lot sequential number.

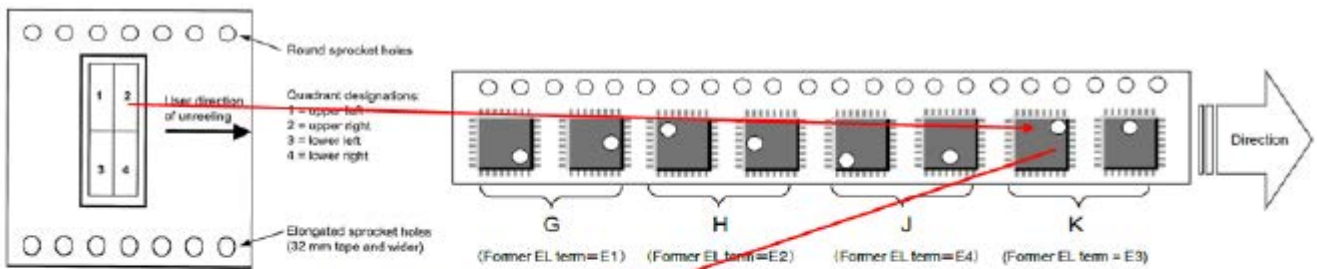

Table 5-7-1 IC Packing Types

Code	Description
A	Tray, bulk
B	Tray, full carton
C	Magazine, unpacked
D	Magazine, full carton
E	Chip tray
F	Wafer case
G	Embossed taping : 1Pin right-ender & right-middle (See the figure below)
H	Embossed taping : 1Pin left-upper & left-middle (See the figure below)
J	Embossed taping : 1Pin left-ender & under-middle (See the figure below)
K	Embossed taping : 1Pin right-upper & upper-middle (See the figure below)
L	Embossed taping small sample : 1Pin right-ender & right-middle (See G figure below) *1
M	Embossed taping small sample : 1Pin left-upper & left-middle (See H figure below) *1
N	Embossed taping small sample : 1Pin left-ender & under-middle (See J figure below) *1
P	Embossed taping small sample : 1Pin right-upper & upper-middle (See K figure below) *1

Figure 15. Pin 1 Orientation in Tape and Reel Packaging

## 8. Ordering Information

Table 53. Ordering Information

Part Number	Description	Number of Output Pairs	Carrier Type <sup>[1]</sup>	Pkg. Desc.	Temp. Range
RC21008B000GND#BB0	Un-programmed part with external crystal. I2C address is 0x09.	8	Tray	5 × 5 × 0.9 mm, 40-QFN	-40° to +85°C
RC21008B000GND#KB0			Tape and Reel		
RC21012B000GNA#BB0		12	Tray	6 × 6 × 0.9 mm, 48-VFQFPN	
RC21012B000GNA#KB0			Tape and Reel		
RC21008B001GND#BB0	Un-programmed part with external crystal for use with external I2C EEPROM. I2C address is 0x09 after I2C EEPROM is loaded.	8	Tray	5 × 5 × 0.9 mm, 40-QFN	-40° to +85°C
RC21008B001GND#KB0			Tape and Reel		
RC21012B001GNA#BB0		12	Tray	6 × 6 × 0.9 mm, 48-VFQFPN	
RC21012B001GNA#KB0			Tape and Reel		
RC21008BdddGND#BB0 <sup>[2]</sup>	Preprogrammed part with external crystal.	8	Tray	5 × 5 × 0.9 mm, 40-QFN	-40° to +85°C
RC21008BdddGND#KB0 <sup>[2]</sup>			Tape and Reel		
RC21012BdddGNA#BB0 <sup>[2]</sup>		12	Tray	6 × 6 × 0.9 mm, 48-VFQFPN	
RC21012BdddGNA#KB0 <sup>[2]</sup>			Tape and Reel		
RC21005BQ00GL2#BB0	Un-programmed part with internal crystal. I2C address is 0x09.	5	Tray	4 × 4 × 1.0 mm, 32-LGA	-40° to +85°C
RC21005BQ00GL2#KB0			Tape and Reel		
RC21008BQ00GL2#BD0		8	Tray	5 × 5 × 1.7 mm, 40-LGA	
RC21008BQ00GL2#KD0			Tape and Reel		
RC21012BQ00GL3#BB0		12	Tray	6 × 6 × 0.9 mm, 48-LGA	
RC21012BQ00GL3#KB0			Tape and Reel		
RC21005BQ01GL2#BB0	Un-programmed part with internal crystal for use with external I2C EEPROM. I2C address is 0x09 after I2C EEPROM is loaded.	5	Tray	4 × 4 × 1.0 mm, 32-LGA	-40° to +85°C
RC21005BQ01GL2#KB0			Tape and Reel		
RC21008BQ01GL2#BD0		8	Tray	5 × 5 × 1.7 mm, 40-LGA	
RC21008BQ01GL2#KD0			Tape and Reel		
RC21012BQ01GL3#BB0		12	Tray	6 × 6 × 0.9 mm, 48-LGA	
RC21012BQ01GL3#KB0			Tape and Reel		
RC21005BQddGL2#BB0 <sup>[2]</sup>	Preprogrammed part with internal crystal.	5	Tray	4 × 4 × 1.0 mm, 32-LGA	-40° to +85°C
RC21005BQddGL2#KB0 <sup>[2]</sup>			Tape and Reel		
RC21008BQddGL2#BD0 <sup>[2]</sup>		8	Tray	5 × 5 × 1.7 mm, 40-LGA	
RC21008BQddGL2#KD0 <sup>[2]</sup>			Tape and Reel		
RC21012BQddGL3#BB0 <sup>[2]</sup>		12	Tray	6 × 6 × 0.9 mm, 48-LGA	
RC21012BQddGL3#KB0 <sup>[2]</sup>			Tape and Reel		

1. Tape and Reel pin 1 orientation follows EIA-481-D unless noted.
2. Replace “ddd” or “dd” with the preprogrammed configuration code provided by Renesas in response to a custom configuration request.

## 9. Revision History

Revision	Date	Description
1.26	Feb 2, 2026	<ul style="list-style-type: none"> <li>Corrected the 100kHz class maximum values for <math>T_F</math> and <math>T_R</math> in <a href="#">Table 41</a>. In previous releases of this document, the values were incorrectly swapped.</li> </ul>
1.25	Oct 30, 2025	<ul style="list-style-type: none"> <li>Changed all references to <i>PCIe Base Specification, Revision 6.0</i> to <i>PCIe Base Specification, Revision 7.0</i></li> </ul>
1.24	Sep 24, 2025	<ul style="list-style-type: none"> <li>Added <a href="#">XIN_REFIN/XOUT_REFINB</a></li> <li>Updated <a href="#">GPIO/GPI Pins</a></li> </ul>
1.23	Jul 22, 2025	<ul style="list-style-type: none"> <li>Fixed some typos in <a href="#">Table 9</a> and <a href="#">Table 10</a></li> <li>Added <a href="#">Choosing Crystals</a> and <a href="#">Tuning the Crystal Load Capacitor</a></li> </ul>
1.22	Jun 3, 2025	<ul style="list-style-type: none"> <li>Updated the ninth bullet in <a href="#">Features</a> to “400kHz I<sup>2</sup>C / SMBus or 20MHz SPI support”</li> <li>Completed other minor changes</li> </ul>
1.21	Feb 11, 2025	<ul style="list-style-type: none"> <li>Updated front page text to indicate PCIe Gen7 compliance</li> <li>Changed nOUT0b to OUT0b in <a href="#">Table 1</a> and <a href="#">Table 2</a></li> <li>Added <a href="#">Table 17</a></li> <li>Updated PCIe Refclk phase jitter tables as follows: <ul style="list-style-type: none"> <li>Added PCIe Gen7 CC and Gen7 IR to the tables</li> <li>Listed IR with no SSC (SRNS) separately from IR with SSC (SRIS)</li> <li>Separated SSC for the IR parameters according to the PCIe SIG specification</li> <li>Separated Clock Generator and Fanout mode additive jitter into separate tables</li> <li>Merged VDDO = 1.8V/2.5V/3.3V into single table</li> </ul> </li> <li>Updated t<sub>HD:DAT</sub> in I<sup>2</sup>C/SMBus Bus AC Electrical Characteristics from 300ns to 0ns to be compatible with <i>SMBus Specification Version 3.2</i>. Updated footnotes accordingly</li> <li>Updated <a href="#">Table 41</a> as follows: <ul style="list-style-type: none"> <li>Changed “master/slave” references to “host/target”</li> <li>Removed maximum values of t<sub>HIGH</sub></li> <li>Corrected Clock/Data Fall Time and Clock/Data Rise Time values</li> </ul> </li> </ul>
1.20	Jun 24, 2024	<ul style="list-style-type: none"> <li>Updated the output duty cycle in <a href="#">Table 26</a> and <a href="#">Table 27</a></li> </ul>
1.19	Jun 4, 2024	<ul style="list-style-type: none"> <li>Updated the packaging information for the 32-LGA package in <a href="#">Ordering Information</a></li> </ul>
1.18	May 1, 2024	<ul style="list-style-type: none"> <li>Added <a href="#">Table 34</a> (CLKIN Differential Electrical Characteristics)</li> </ul>
1.17	Apr 5, 2024	<ul style="list-style-type: none"> <li>Updated the Configuration and OTP bullets in <a href="#">Features</a></li> <li>Added cross-references in <a href="#">Table 1</a>, <a href="#">Table 2</a>, <a href="#">Table 3</a>, <a href="#">Table 4</a>, and <a href="#">Table 5</a> to <a href="#">Table 8</a></li> </ul>
1.16	Mar 13, 2024	<ul style="list-style-type: none"> <li>Updated several part numbers in <a href="#">Ordering Information</a> (RC21012BQ00GL3#BB0, RC21012BQ00GL3#KB0, RC21012BQ01GL3#BB0, and RC21012BQ01GL3#KB0)</li> </ul>
1.15	Feb 15, 2024	<ul style="list-style-type: none"> <li>Updated block diagram on front page to show the RC21005 variant</li> <li>Added BQ part information to Front page, <a href="#">Pin Information</a>, <a href="#">Table 50</a>, <a href="#">Table 51</a>, <a href="#">Table 52</a>, <a href="#">Marking Diagrams</a>, and <a href="#">Ordering Information</a></li> <li>Rearranged <a href="#">Ordering Information</a> for readability</li> <li>Completed other minor changes</li> </ul>
1.14	Jan 9, 2024	<ul style="list-style-type: none"> <li>Updated the typical and maximum values for t<sub>ΦAPLL</sub> in <a href="#">Table 22</a></li> <li>Updated the document to the latest template</li> </ul>
1.13	Dec 21, 2023	<ul style="list-style-type: none"> <li>Added <a href="#">Static Phase Offset - Zero Delay Buffer Mode</a> table</li> <li>Updated to final for RC21012B and RC21008B devices</li> </ul>
1.12	Nov 10, 2023	<ul style="list-style-type: none"> <li>Corrected a package link in <a href="#">Ordering Information</a></li> </ul>
1.11	Oct 27, 2023	<ul style="list-style-type: none"> <li>Updated the down-spread maximum value in <a href="#">Table 33</a></li> </ul>
1.10	Aug 15, 2023	<ul style="list-style-type: none"> <li>Corrected the description of the RC21008B000GND#BB0 part in <a href="#">Ordering Information</a></li> </ul>
1.09	May 31, 2023	<ul style="list-style-type: none"> <li>Changed t<sub>HOLD</sub> to 200uS from 200mS in <a href="#">Figure 13</a></li> </ul>
1.08	May 8, 2023	<ul style="list-style-type: none"> <li>Updated the device block diagram in <a href="#">Figure 1</a></li> </ul>
1.07	Apr 14, 2023	<ul style="list-style-type: none"> <li>Corrected an RC21005BQ part number in <a href="#">Ordering Information</a></li> </ul>

Revision	Date	Description
1.06	Mar 29, 2023	<ul style="list-style-type: none"> <li>▪ Updated document for B revision as follows:                             <ul style="list-style-type: none"> <li>• Updated front page references to B revision and simplified the block diagram</li> <li>• Added RC21012BQ pin assignments and pin descriptions</li> <li>• Added RC21005BQ pin assignments and pin descriptions</li> <li>• Updated ordering information with new devices and revisions</li> <li>• Changed ePad outline and ePad text in the Pin Diagrams to grey color to highlight that the view is Top View and the ePad is on the bottom of the package</li> <li>• Added thermal data for 005BQ and 012BQ package</li> <li>• Corrected all theta ja descriptions from 0, 1, 3, and 5 m/s airflow to 0, 1, 2, and 3 m/s airflow</li> <li>• Updated <a href="#">Power Considerations</a> for the B-rev silicon</li> </ul> </li> </ul>
1.05	Nov 22, 2022	<ul style="list-style-type: none"> <li>▪ Added LVC MOS AC/DC characteristics tables (see <a href="#">Table 23</a> to <a href="#">Table 25</a>)</li> <li>▪ Completed an extensive update to <a href="#">Power Considerations</a>, specifically power sequencing considerations</li> <li>▪ Clarified <a href="#">Overdriving the XTAL Interface</a></li> </ul>
1.04	Oct 12, 2022	<ul style="list-style-type: none"> <li>▪ Changed the minimum value for <math>t_{PU}</math> in <a href="#">Table 8</a></li> <li>▪ Removed references to RC21005A pending final qualification. For the latest documentation on this device, please contact Renesas</li> <li>▪ Completed other minor changes</li> </ul>
1.03	Sep 19, 2022	<ul style="list-style-type: none"> <li>▪ Updated the <a href="#">Marking Diagrams</a> and <a href="#">Ordering Information</a>, added 01 and 001 dash codes to indicate configurations that load from external I2C EEPROMs. Updated footnotes</li> <li>▪ Updated <a href="#">Power Sequencing Considerations</a></li> </ul>
1.02	Aug 31, 2022	<ul style="list-style-type: none"> <li>▪ Completed minor updates to various <a href="#">Electrical Characteristics</a> values</li> </ul>
1.01	Aug 9, 2022	<ul style="list-style-type: none"> <li>▪ Corrected a typo in <a href="#">Pin Assignments – RCxxx12B (Top View)</a></li> <li>▪ Completed minor updates to various <a href="#">Electrical Characteristics</a> values</li> <li>▪ Completed other minor changes</li> </ul>
1.00	Jul 22, 2022	Initial release

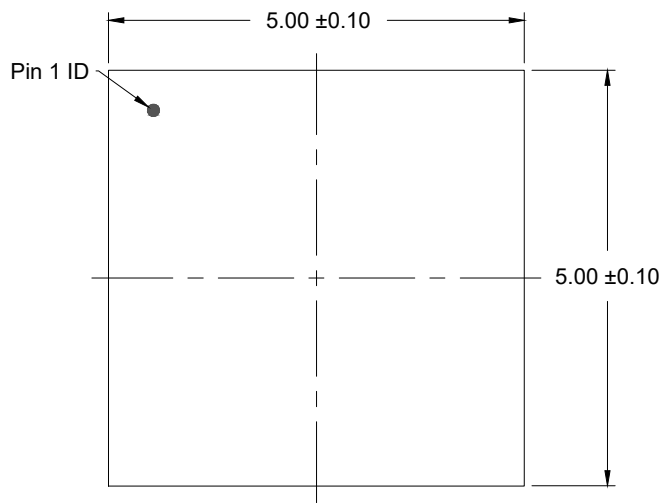

TOP VIEW

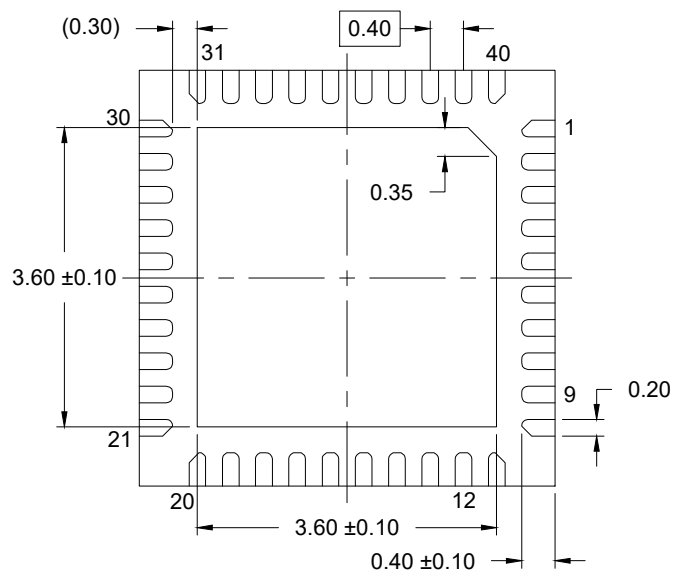

BOTTOM VIEW

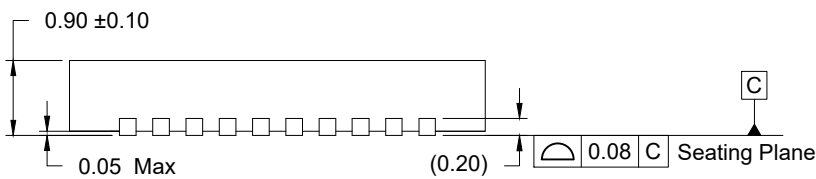

SIDE VIEW

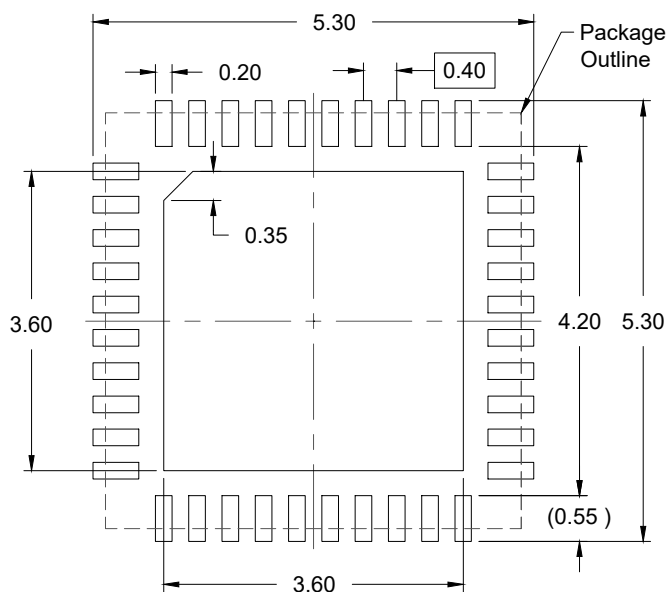

RECOMMENDED LAND PATTERN  
(PCB Top View, NSMD Design)

NOTES:

1. JEDEC compatible.
2. All dimensions are in mm and angles are in degrees.
3. Use  $\pm 0.05$  mm for the non-toleranced dimensions.
4. Numbers in ( ) are for references only.

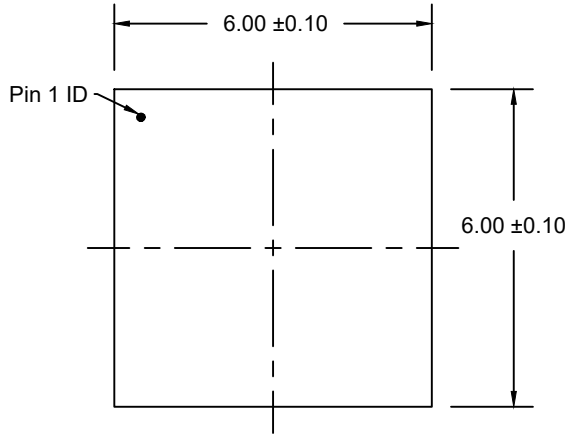

TOP VIEW

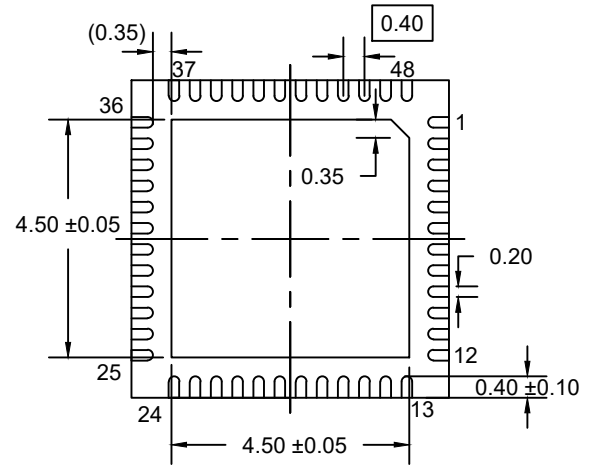

BOTTOM VIEW

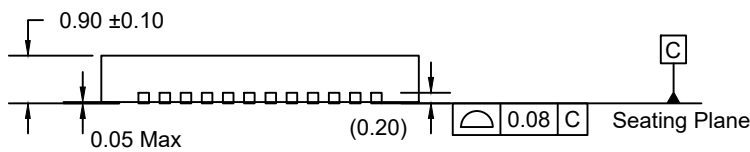

SIDE VIEW

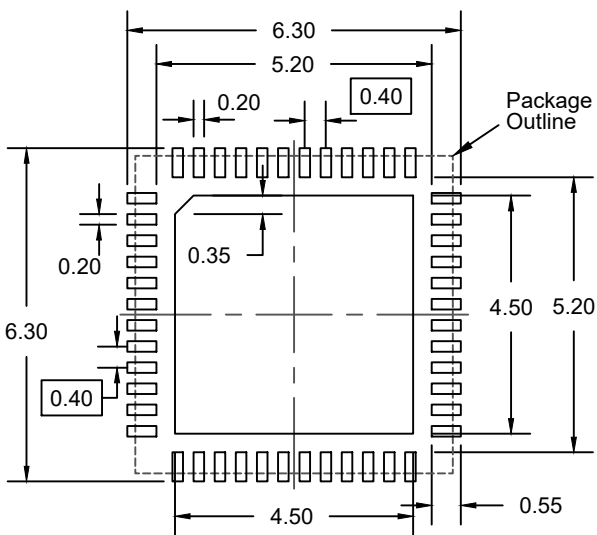

RECOMMENDED LAND PATTERN  
(PCB Top View, NSMD Design)

NOTES:

1. JEDEC compatible.
2. All dimensions are in mm and angles are in degrees.
3. Use  $\pm 0.05$  mm for the non-toleranced dimensions.
4. Numbers in ( ) are for references only.

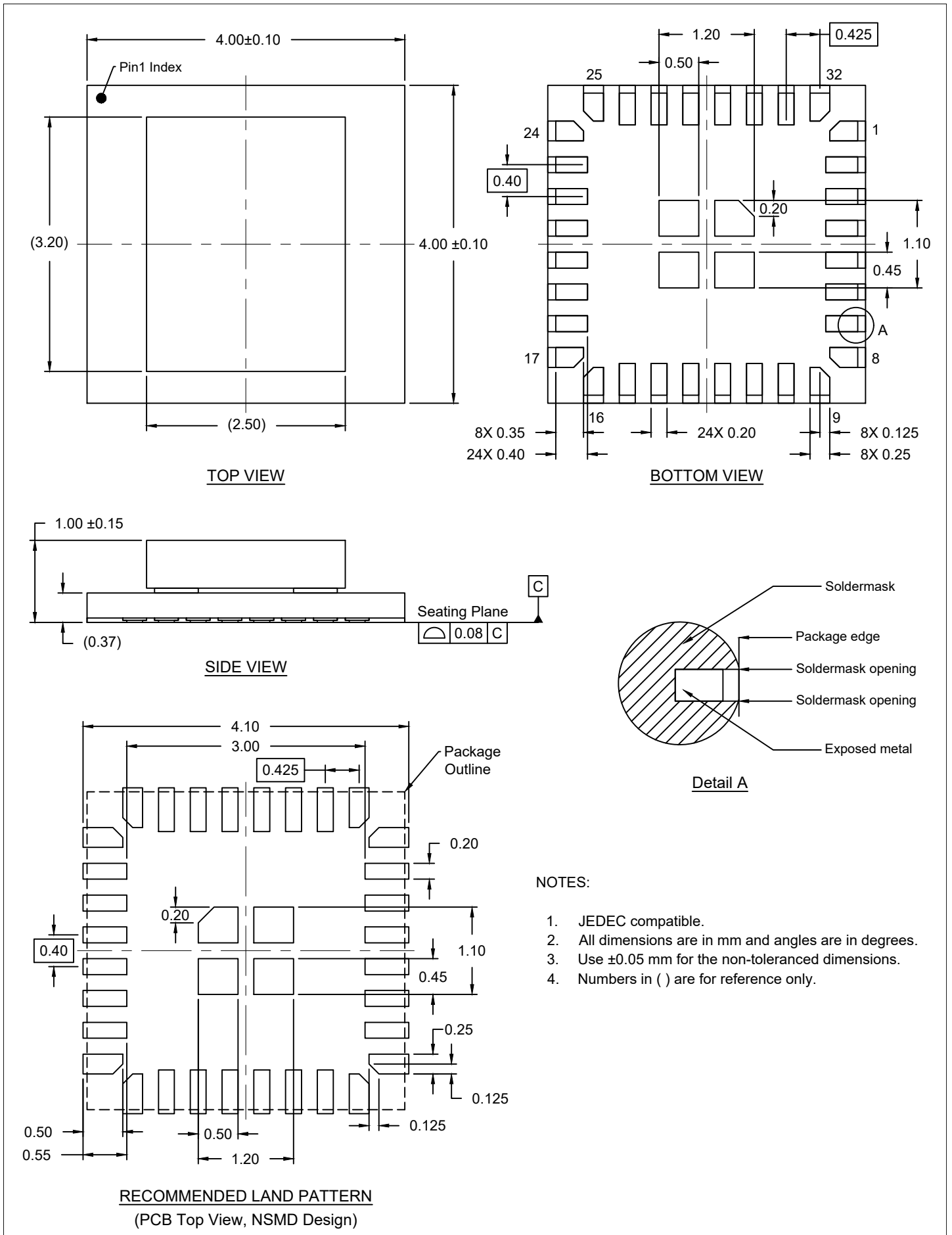

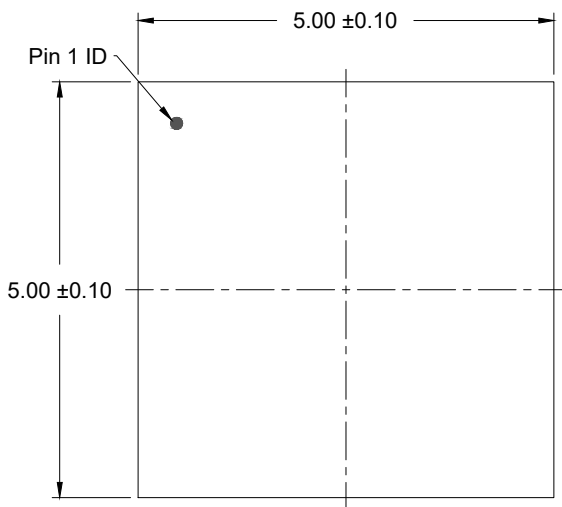

TOP VIEW

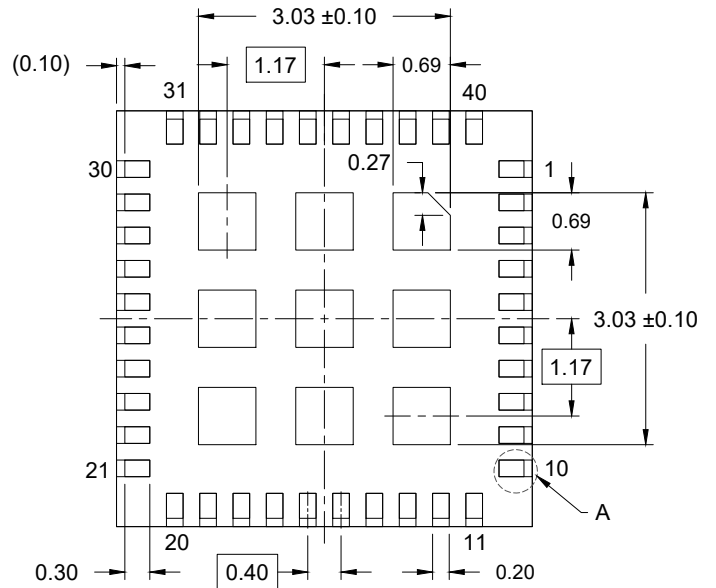

BOTTOM VIEW

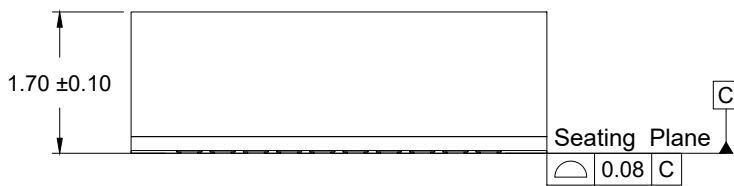

SIDE VIEW

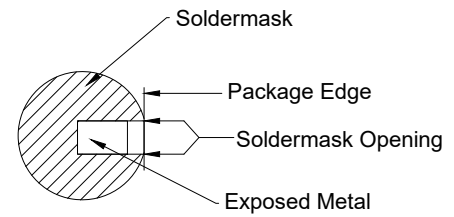

Detail A

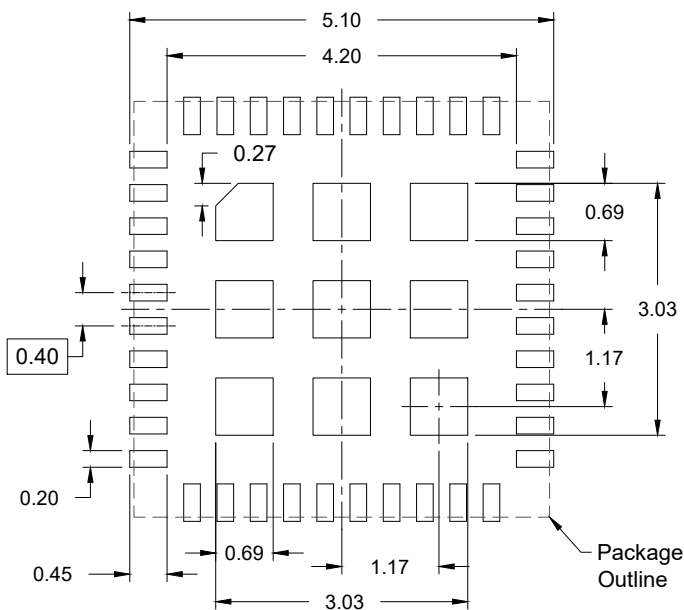

RECOMMENDED LAND PATTERN  
(PCB Top View, NSMD Design)

**NOTES:**

1. JEDEC compatible.
2. All dimensions are in mm and angles are in degrees.
3. Use  $\pm 0.05$  mm for the non-toleranced dimensions.
4. Numbers in ( ) are for references only.

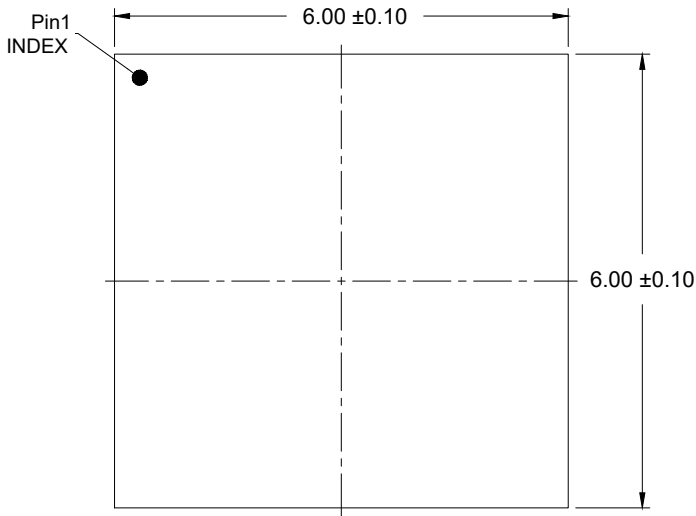

TOP VIEW

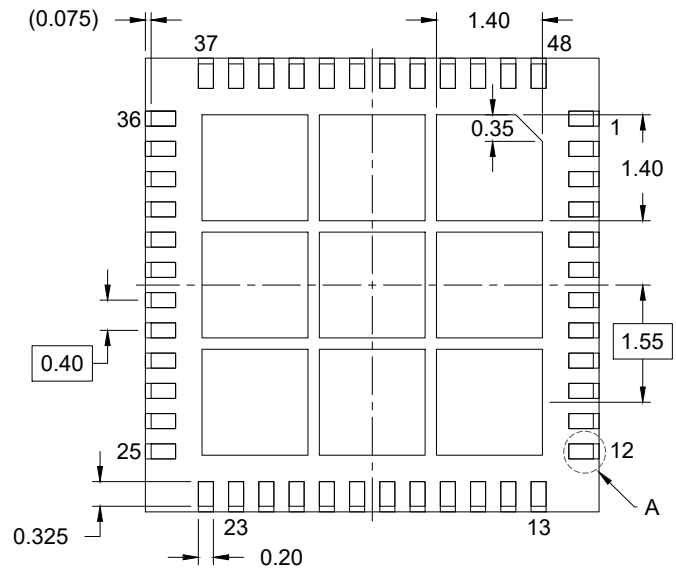

BOTTOM VIEW

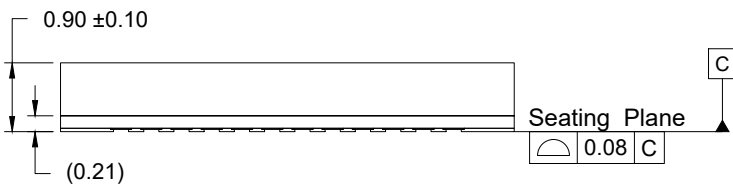

SIDE VIEW

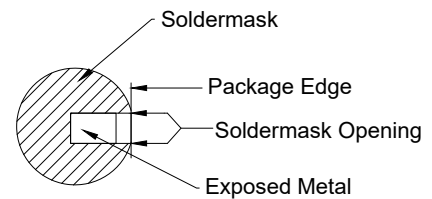

Detail A

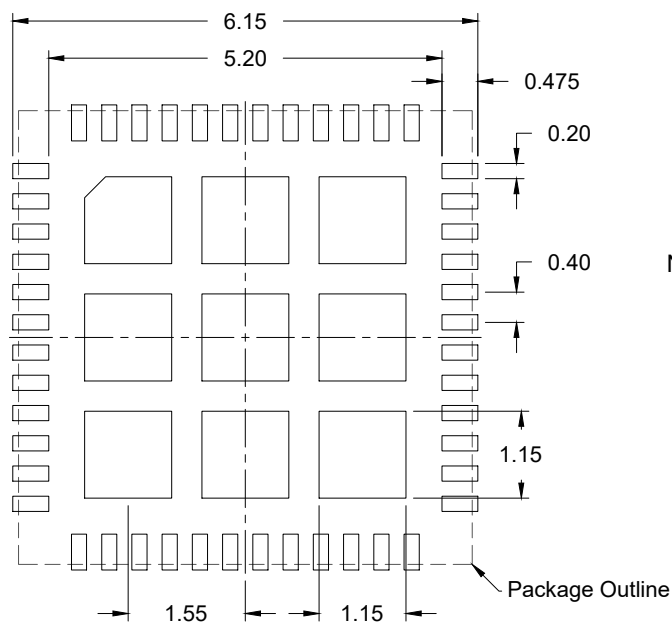

RECOMMENDED LAND PATTERN

(PCB Top View, Lead pad - NSMD Design; Thermal pad - SMD Design)

**NOTES:**

1. JEDEC compatible.
2. All dimensions are in mm and angles are in degrees.
3. Use  $\pm 0.05$  mm for the non-toleranced dimensions.
4. Numbers in ( ) are for references only.

## IMPORTANT NOTICE AND DISCLAIMER

RENESAS ELECTRONICS CORPORATION AND ITS SUBSIDIARIES (“RENESAS”) PROVIDES TECHNICAL SPECIFICATIONS AND RELIABILITY DATA (INCLUDING DATASHEETS), DESIGN RESOURCES (INCLUDING REFERENCE DESIGNS), APPLICATION OR OTHER DESIGN ADVICE, WEB TOOLS, SAFETY INFORMATION, AND OTHER RESOURCES “AS IS” AND WITH ALL FAULTS, AND DISCLAIMS ALL WARRANTIES, EXPRESS OR IMPLIED, INCLUDING, WITHOUT LIMITATION, ANY IMPLIED WARRANTIES OF MERCHANTABILITY, FITNESS FOR A PARTICULAR PURPOSE, OR NON-INFRINGEMENT OF THIRD-PARTY INTELLECTUAL PROPERTY RIGHTS.

These resources are intended for developers who are designing with Renesas products. You are solely responsible for (1) selecting the appropriate products for your application, (2) designing, validating, and testing your application, and (3) ensuring your application meets applicable standards, and any other safety, security, or other requirements. These resources are subject to change without notice. Renesas grants you permission to use these resources only to develop an application that uses Renesas products. Other reproduction or use of these resources is strictly prohibited. No license is granted to any other Renesas intellectual property or to any third-party intellectual property. Renesas disclaims responsibility for, and you will fully indemnify Renesas and its representatives against, any claims, damages, costs, losses, or liabilities arising from your use of these resources. Renesas' products are provided only subject to Renesas' Terms and Conditions of Sale or other applicable terms agreed to in writing. No use of any Renesas resources expands or otherwise alters any applicable warranties or warranty disclaimers for these products.

(Disclaimer Rev.1.01)

### Corporate Headquarters

TOYOSU FORESIA, 3-2-24 Toyosu,  
Koto-ku, Tokyo 135-0061, Japan  
[www.renesas.com](http://www.renesas.com)

### Trademarks

Renesas and the Renesas logo are trademarks of Renesas Electronics Corporation. All trademarks and registered trademarks are the property of their respective owners.

### Contact Information

For further information on a product, technology, the most up-to-date version of a document, or your nearest sales office, please visit [www.renesas.com/contact-us/](http://www.renesas.com/contact-us/).

## Looking for pricing, stock, or lifecycle information?

Click below to explore more details on WIN SOURCE:

 [View NTCGS163JF103FT8 on WIN SOURCE](#)

 [TDK Corporation](#) Information

## Optimize Your Supply Chain with WIN SOURCE Solutions

-  Global Sourcing Solution
-  Obsolete Management
-  Cost Control Management
-  Shortage Management
-  Alternative Solution
-  Excess Inventory Management