

FEATURES

Electrical

- Peak Efficiency up to 98%
- PMBus Communication
- Fully protected: Input UVP and OVP. Output OVP, OCP and OTP
- With output oring-fet inside module
- Adjustable current limit
- Remote ON/OFF, negative logic
- Pre-bias startup
- No minimum load required
- Parallel Operation with Active Current Sharing
- Non-isolated, Vin- pin and Vout- pin shorted together inside the power module

Mechanical

Size: 63.2 x 60.6 x 13.0mm (2.49"x2.39"x0.51")

Safety & Certificate

- IEC/EN/UL/CSA 62368-1, 2nd edition
- IEC/EN/UL/CSA 60950-1, 2nd edition+A2
- ISO 9001, TL 9000, ISO 14001, QS 9000, OHSAS18001 certified manufacturing facility

OPTIONS

- PMBus communication
- Constant frequency

SOLDERING METHOD

- Wave soldering
- Hand soldering



H60SB0A050

1/2 Brick DC/DC Regulated Power Module

9~60Vin, 0~60Vout, 50A

H60SB0A050, Half Brick, 9~60V input, non-isolated single output, is regulated DC/DC converter, and is being offered from a world leader in power system and technology and manufacturing — Delta Electronics, Inc. The H60SB0A050 offers up to 50A output and 98% peak efficiency in an industry standard footprint. With creative design technology and optimization of component placement, these converters possess outstanding electrical and thermal performances, as well as extremely high reliability under highly stressful operating conditions. The H60SB0A050 can be connected in parallel for higher power without external Oring-fet.

(T_A=25°C, airflow rate=300 LFM unless otherwise noted.)

PARAMETER	NOTES and CONDITIONS	H60SB0A050			
		Min.	Typ.	Max.	Units
ABSOLUTE MAXIMUM RATINGS					
Input Voltage					
Continuous		0		60	Vdc
Transient	100mS			80	Vdc
Iset/Vset pin				3.5	Vdc
Operating Ambient Temperature (Ta)		-40		85	°C
Storage Temperature		-55		125	°C
Input/Output Isolation Voltage	Non-Isolation			NA	Vdc
INPUT CHARACTERISTICS					
Operating Input Voltage (Vin)		9		60	Vdc
Input Under-Voltage Lockout					
Turn-On Voltage Threshold		7	8	9	Vdc
Turn-Off Voltage Threshold		5	6	7	Vdc
Lockout Hysteresis Voltage				2	Vdc
Input Over-Voltage Protection	Response with 150mS delay			65	Vdc
Input Current Limit	With Input Current limit Function			55	A
	V _{in} =28V, V _{out} = 12V I _o =0A			100	mA
No-Load Input Current	V _{in} =28V, V _{out} = 24V I _o =0A			90	mA
	V _{in} =28V, V _{out} = 48V I _o =0A			180	mA
Off Converter Input Current	V _{in} =48V			2	mA
Internal Input filter components value (C/L/C)			10/0.3/40		µF/µH/µF
Voltage between Vsense+ and +Vout pins				+/-6.0	V
Voltage between Vsense- and -Vout pins				+/-0.25	V
OUTPUT CHARACTERISTICS					
Output Voltage Range (Note 1)		0		60	Vdc
Output Current Range		0		50	A
Output Regulation					
	Vo=24V, Vin=9V, I _o =0A to 14A		600	900	mV
	Vo=24V, Vin=48V, I _o =0A to 35A		1200	1500	mV
	Vo=48V, Vin=24V, I _o =0A to 20A		1500	2000	mV
	Vo=48V, Vin=48V, I _o =0A to 35A		2500	3000	mV
	Vo=48V, Vin=60V, I _o =0A to 50A		3000	3500	mV
Load Regulation					
	Between sense pins, over line, load, temp		+/-100mV	+/- 0.5%Vout	+Load Regulation
Total Output Voltage Range					
Output Voltage Ripple and Noise	5Hz to 20MHz bandwidth, Co=100uF				
Peak-to-Peak	V _{in} =28V, V _o =12V, 50A		110		mV
Peak-to-Peak	V _{in} =28V, V _o =24V, 50A		100		mV
Peak-to-Peak	V _{in} =28V, V _o =48V, 25A		100		mV
Output Over Current Limitation				55	A
Output Capacitance Range		100		15000	µF
Output Over Voltage Protection (latch mode)					
	Vo set point < 3.5V		5		V
	3.5V < Vo set point < 47.5V		1.43 * Vo set point		V
	Vo set point > 47.5V		68		V
DYNAMIC CHARACTERISTICS					
Output Voltage Current Transient	V _{in} =28V, V _{out} = 12V, Co=100uF, 0.1A/µs				
Positive Step Change in Output Current	75% I _{o,max} to 50% I _{o,max}		600		mV
Negative Step Change in Output Current	50% I _{o,max} to 75% I _{o,max}		400		mV
Settling Time (within 1% nominal V _{out})					µs
Turn-On Delay and Rise Time					
Start-Up Delay Time From Input Voltage	On/Off=On, from V _{in} =Turn-on Threshold to V _o =10% V _{o,nom}		30		mS
Start-Up Delay Time From On/Off Control	V _{in} =V _{in,nom} , from On/Off=On to V _o =10% V _{o,nom}		30		mS
Output Voltage Rise Time Slew Rate	V _o =10% to 90% V _{o,nom}		0.3		V/mS
Output Voltage Overshoot at Start-Up			0		V
EFFICIENCY					
100% Load					
	V _{in} =12V, V _{out} = 48V		93.0		%
	V _{in} =24V, V _{out} = 48V		96.0		%
	V _{in} =48V, V _{out} = 12V		93.0		%
FEATURE CHARACTERISTICS					
Switching Frequency (Note 2)	H60SB0A050NRDE		280		KHz
	H60SB0A050 other series Vo close to Vin		140		KHz
	H60SB0A050 other series Vo not close to Vin		280		KHz
On/Off Control, Negative Remote On/Off logic					
Logic Low (Module On)	V _{on/off}	0		0.8	V
Logic High (Module Off)	V _{on/off}	3.5		Vin	V
ON/OFF Current	Ion/off at Von/off=0.0V			1	mA
Leakage Current	Logic High, Von/off=5V			1	mA
Ishare/I _{mon}					
Pin voltage at no load			0.2		V
Pin voltage at full load(50A)			2.7		V
GENERAL SPECIFICATIONS					
MTBF	I _o =80% of I _{o,max} ; T _a =25°C	1.2			Mhours
Weight (with base plate and encased)			155		grams
Over-Temperature Shutdown (With base-plate)	Refer to Figure 18 for Hot spot location (48V _{in} , 12V _{out} , 80% Output Power)		110		°C

Note:

- Vset pin (9) is the default output voltage setting Pin. It can be disabled and set output voltage by PMBus. Refer to PMBus commands specifically.
- H60SB0A050NRDE efficiency is 1.3% less than the H60SB0A050 other series when Vo close to Vin. They are equally efficiency when Vo not close to Vin. H60SB0A050 other series efficiency refer to the Figure 1 of P4.

PARAMETER	NOTES and CONDITIONS	H60SB0A050			
		Min.	Typ.	Max.	Units
PMBUS SIGNAL INTERFACE CHARACTERISTICS					
Logic Input Low (V _{IL})	Data, SMBAlert, Clock pin	0		0.8	V
Logic Input High (V _{IH})	Data, SMBAlert, Clock pin	2.1		3.3	V
Logic Output Low (V _{OL})	Data, SMBAlert, Clock pin; IOL=6mA			0.4	V
Logic Output High (V _{OH})	Data, SMBAlert, Clock pin; IOH=-6mA			2.6	V
PMBus Operating Frequency Range		100		400	KHz
PMBUS MONITORING CHARACTERISTICS					
Output Current Reading Accuracy	I _o =50% ~ 100% of I _o , max; I _o =5% ~ 50% of I _o , max;	-5		+5	%
Output Voltage Reading Accuracy		-3		+3	A
Input Voltage Reading Accuracy		-2		+2	%
Temperature Reading Accuracy		-4		+4	%
		-5		+5	°C

SUGGESTED APPLICATION CIRCUIT

Note1: Refer to page9 for Addr1 and Addr0 pin implementation

Note2&3: Refer to page7 for Iset and Vset pin implementation

Note4: Should short the Vin- pin and Vout- pin together for better EMI performance, refer to page 7 EMC test result.

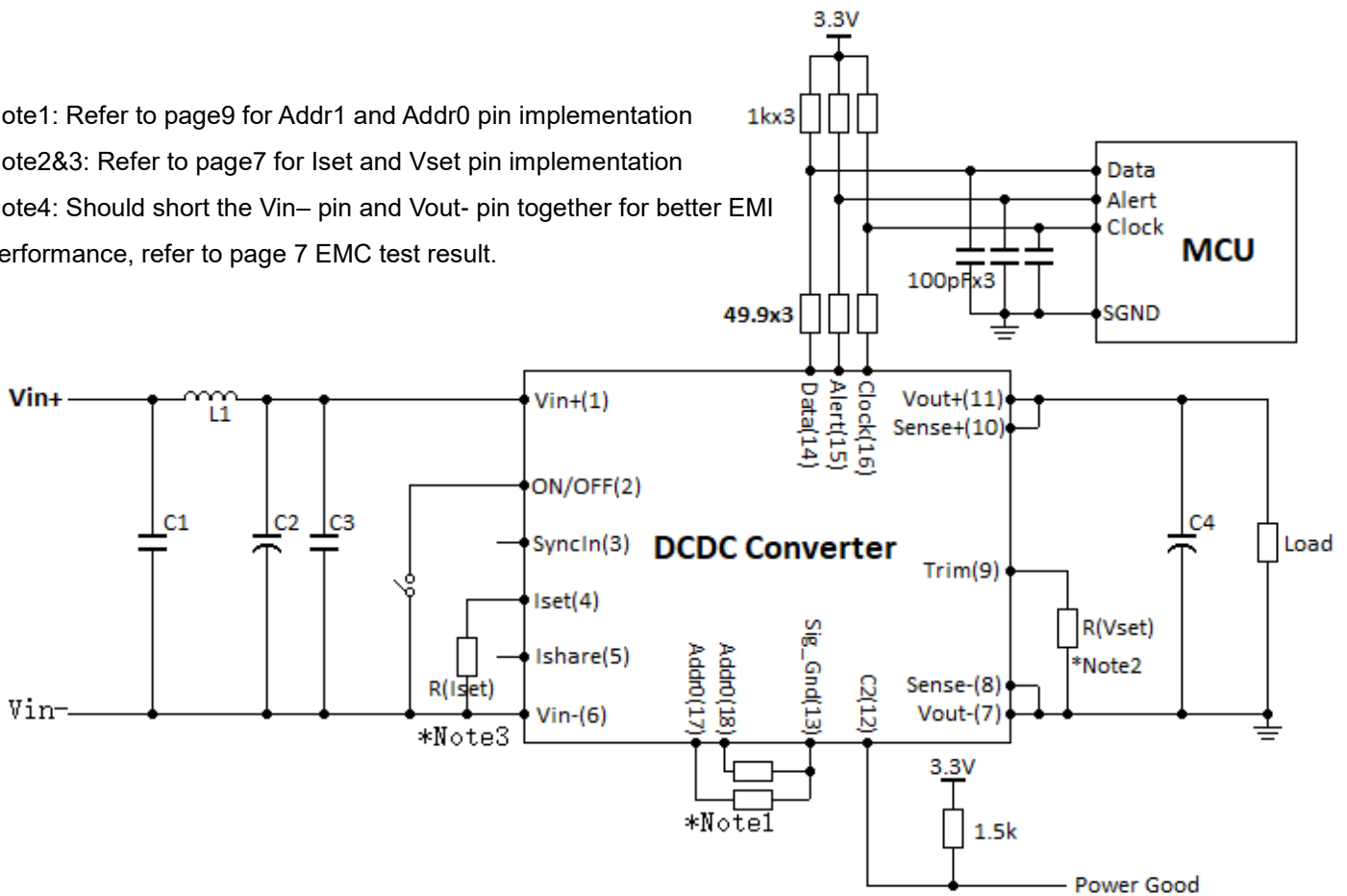

Location	Value	Manufacturer	Part Number	Quantity(Pcs)
Fuse	80A	Littlefuse	0456040.DR (40A)	2
L1	3.3uH			1
C1	2.2uF/100V MLCC	TDK	C3225X7R2A225KT000S	4
C2	470uF/100V electrolytic cap	NCC	EKZN101EC3471MLN31 (470uF/100V)	1
C3	2.2uF/100V MLCC	TDK	C3225X7R2A225KT000S	18
C4	470uF/100V electrolytic cap	NCC	EKZN101EC3471MLN31 (470uF/100V)	1
C5	2.2uF/100V MLCC	TDK	C3225X7R2A225KT000S	4

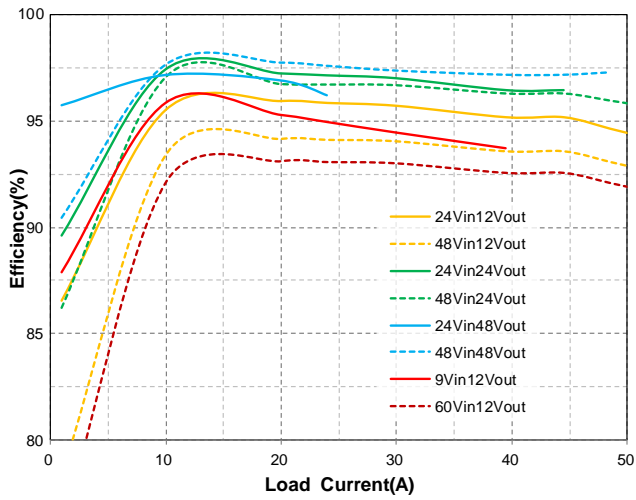

Figure 1: Efficiency vs. Load Current at Ta=25°C

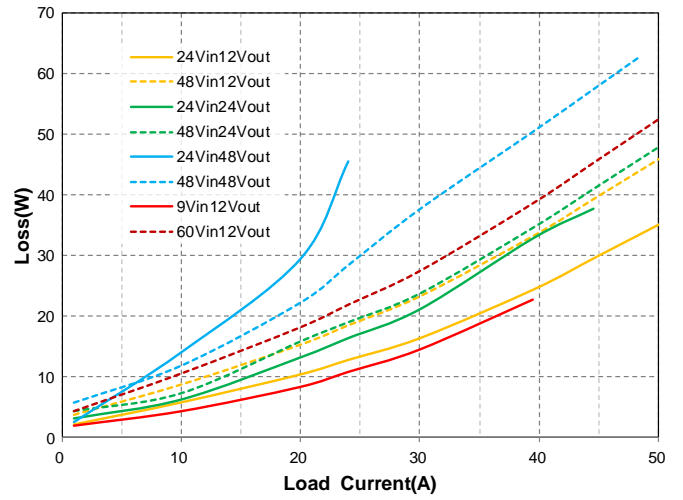

Figure 2: Loss vs. Output Power at Ta=25°C

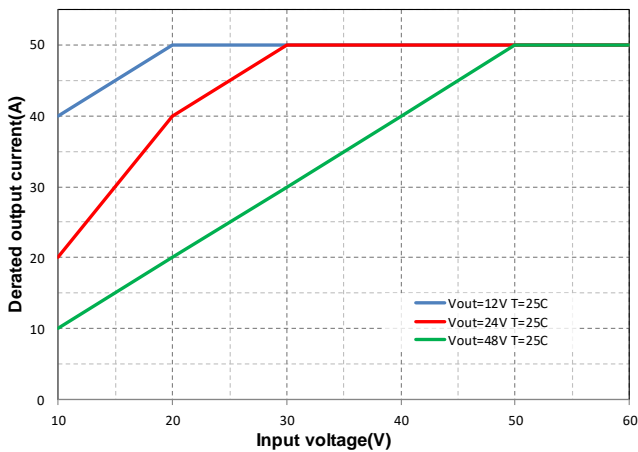

Figure 3: Input Voltage vs. Output Current showing typical current limit curves.

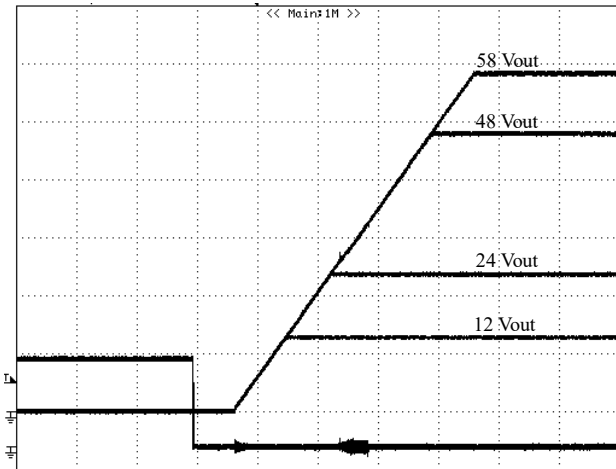

Figure 4: Remote On/Off (negative logic) at no load
 $V_{in} = 28V$
 Time: 50ms/div.
 V_{out} (top trace): 12Vout, 24Vout, 48Vout, 58Vout, 10V/div;
 $V_{remote\ On/Off\ signal}$ (bottom trace): 5V/div.

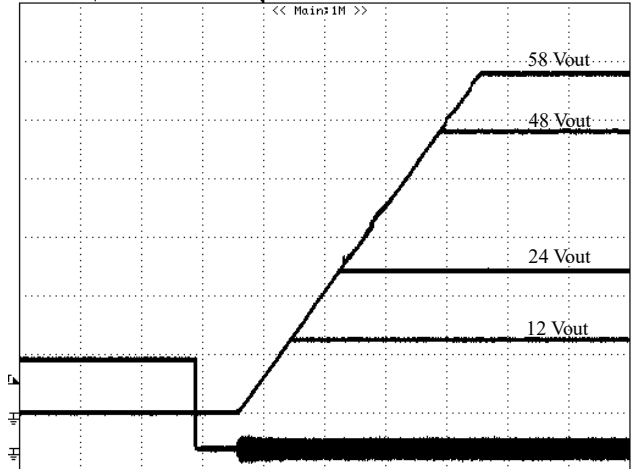

Figure 5: Remote On/Off (negative logic) at full load
 $V_{in} = 28V$
 Time: 50ms/div.
 V_{out} (top trace): 12Vout, 24Vout, 48Vout, 58Vout, 10V/div;
 $V_{remote\ On/Off\ signal}$ (bottom trace): 5V/div.

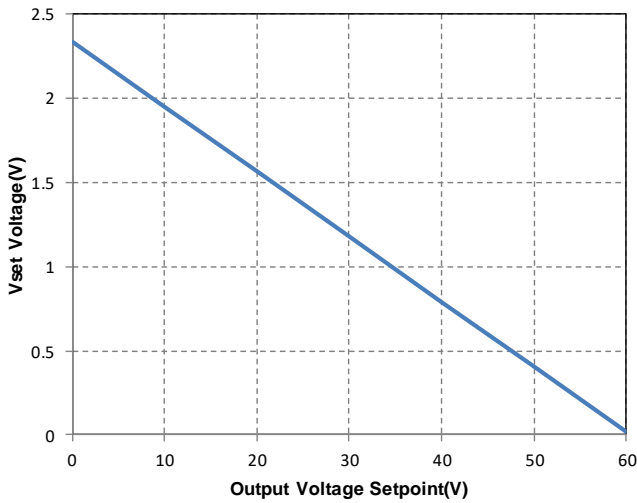

Figure 6: Vset pin voltage vs. Output voltage set point.

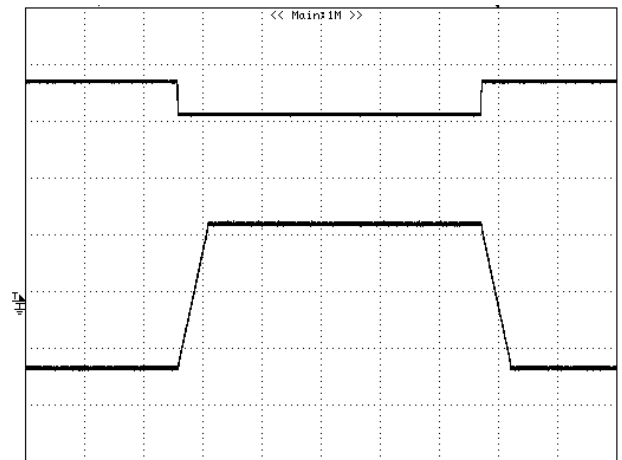

Figure 7: Output Voltage vs. Vset pin voltage dynamic;
 $V_{in} = 28V$, $I_o = 10A$
 Time: 50ms/div.
 Top trace: Vset pin voltage(500mV/div)
 Bottom trace: Output Voltage(3V/div)

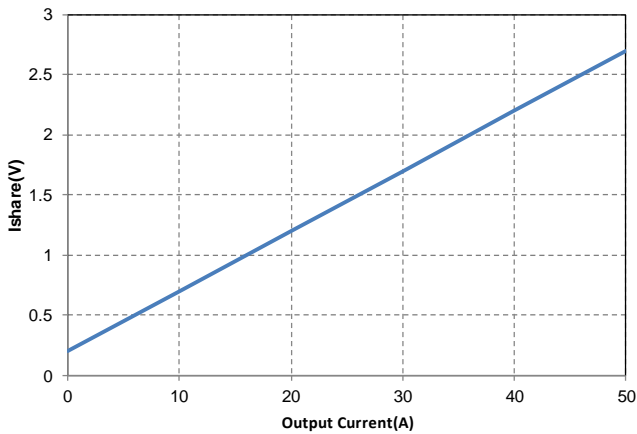

Figure 8: Ishare/Imon pin voltage vs. output load current.

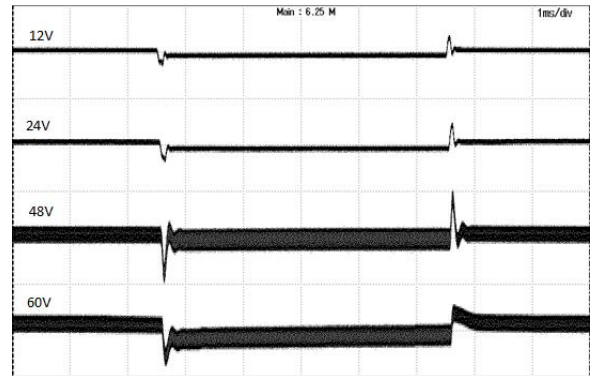

Figure 9: Transient Response
 (28Vin, di/dt=0.1A/Us, from top trace to bottom trace
 12Vout, 25A-37.5A-25A; 24Vout, 25A-37.5A-25A;
 48Vout, 12A-18A-12A; 60Vout, 5A-7.5A-5A.
 2V/div, 1ms/div; Cout is 100uF.

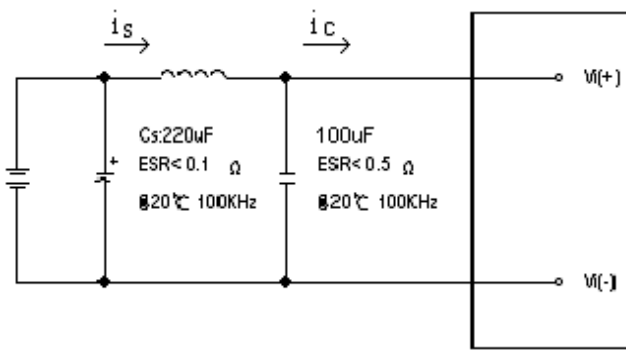

Figure 10: Test Setup Diagram for Input Ripple Current
 Note: Measured input reflected-ripple current with a simulated source Inductance (L_{TEST}) of 12 μ H. Capacitor C_s offset possible battery impedance. Measure current as shown above.

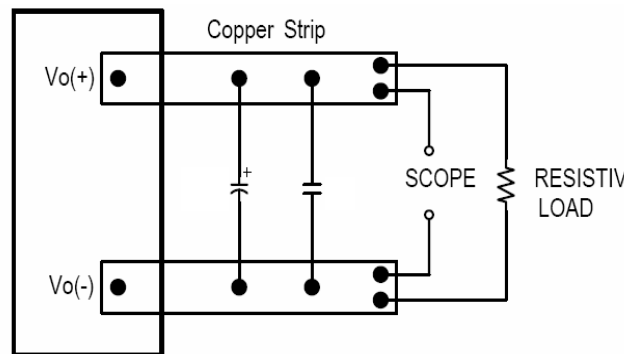

Figure 11: Test Setup for Output Voltage Noise and Ripple

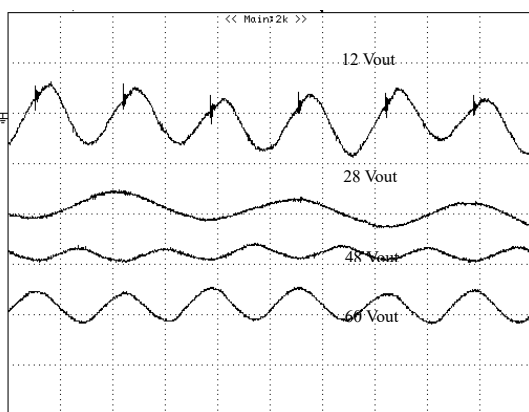

Figure 12: Input Terminal Ripple Current, i_c , at max output current and nominal input voltage(28V) with 12 μ H source impedance and 33 μ F electrolytic capacitor (50 mA/div, 2us/div).

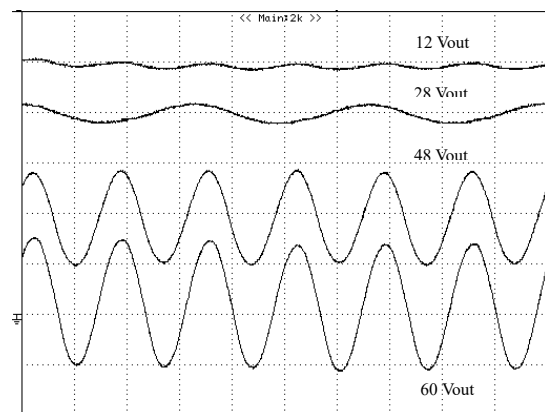
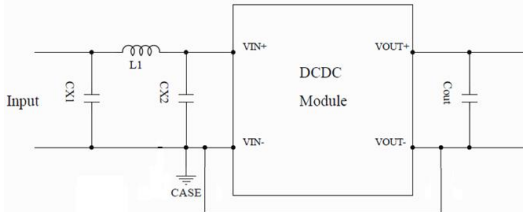

Figure 13: Output Voltage Ripple and Noise at input voltage(28V) and rated load current (500 mV/div)
 Load capacitance: 100uF. Bandwidth: 20MHz, (2us/div)

Layout and EMC Considerations

Delta's DC/DC power modules are designed to operate in a wide variety of systems and applications. For design assistance with EMC compliance and related PWB layout issues, please contact Delta's technical support team.

Schematic and Components List



	CX1	L1	CX2	Cout
Parameter	2.2uF*4 MLCC	3.3uH	470uF/100V +2.2uF*18 MLCC	470uF/100V +2.2uF*4 MLCC

Test result:

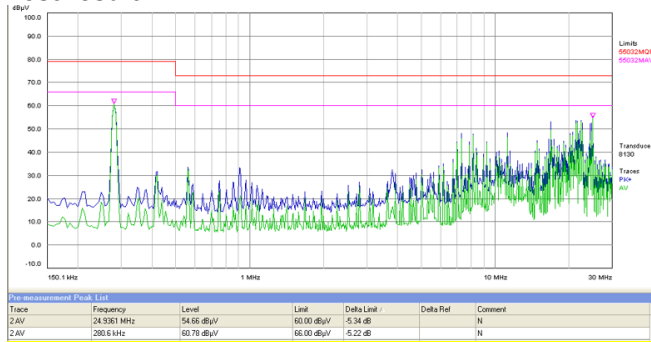

Short CASE to Ground in EMC test

Safety Considerations

The power module must be installed in compliance with the spacing and separation requirements of the end-user's safety agency standard, i.e. IEC 62368-1: 2014 (2nd edition), EN 62368-1: 2014 (2nd edition), UL 62368-1, 2nd Edition, 2014-12-01 and CSA C22.2 No. 62368-1-14, 2nd Edition, 2014-12. UL60950-1, CSA C22.2 NO. 60950-1 2nd, IEC 60950-1 2nd: 2005, EN 60950-1 2nd: 2006+A11+A1: 2010, if the system in which the power module is to be used must meet safety agency requirements.

Both the input and output of this product meet SELV requirement.

This power module is not internally fused. To achieve optimum safety and system protection, an input line fuse is highly recommended. The safety agencies require a normal-blow fuse with 70A maximum rating to be installed in the ungrounded lead. A lower rated fuse can be used based on the maximum inrush transient energy and maximum input current.

Two rated 40A/72Vdc external fuse in parallel, from Littelfuse type 456 series.

The equipment shall be supplied from a DC source that provides double/reinforced insulation from AC mains.

Remote On/Off

The remote on/off feature on the module is negative logic. Negative logic turns the module on during logic low and off during logic high. Remote on/off can be controlled by an external switch between the on/off terminal and the Vin(-) terminal. The switch can be an open collector or open drain. For negative logic if the remote on/off feature is not used, please short the on/off pin to Vin(-).

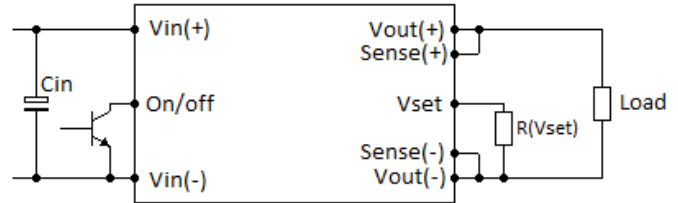

Figure 14: Remote On/Off Implementation

Output Voltage Set Point

The output voltage can be programmed to any voltage between 0Vdc and 60Vdc by connecting one resistor, R(Vset), between the Vset pin (9) and Vout- pin (7); See Figure 15. For a desired output voltage, the value of the resistor should be:

$$R_{Vset}(V_{set}) = \left[\left(\frac{714900}{V_o + 3.459} \right) - 10870 \right] (\Omega)$$

Alternatively, the Vset pin can be driven from an external voltage source:

$$V_{Vset}(V_{set}) = 2.366 - 0.038V_o$$

Vo = desired output voltage set point

Undriven, this pin floats at 2.5V which sets the output to 0V.

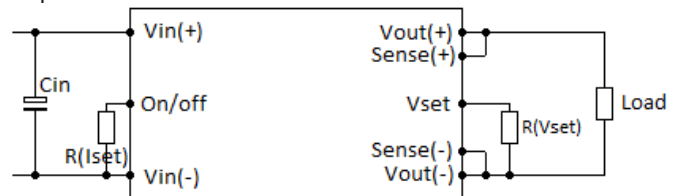

Figure 15

R(Vset) or the external voltage source should be connected to Vout- pin (7) directly to minimize impact of parasitic parameter;

Output Current Setting

The maximum output current (effectively the current limit) can be reduced to any value between 0 and Imax by connecting one resistor, R(Iset), between the Iset pin (4) and Vin- pin (6); see Figure 15. The value of the resistor should be:

$$R_{Iset}(I_{set}) = \frac{25I_{set}}{3.3I_{max} - 2.5I_{set}} (k\Omega)$$

Alternatively, the Iset pin can be driven from an external voltage source:

$$V_{Iset}(I_{set}) = 2.5 \times \frac{I_{set}}{I_{max}}$$

Iset = desired output current set point

Imax = maximum rated output current (50A)

Undriven, Iset pin floats to 3.3V which sets the current limit at its nominal value of 110% * Imax.

R(Iset) or the external voltage source should be connected to Vin- pin (6) directly to minimize impact of parasitic parameter;

Over-Current Protection

The modules include an internal output over-current protection circuit, which will endure current limiting for an unlimited duration during output overload. If the output current exceeds the OCP set point, the modules will shut down (hiccup mode). The modules will try to restart after shutdown. If the overload condition still exists, the module will shut down again. This restart trial will continue until the overload condition is removed.

Over-Voltage Protection

The modules include an internal input over-voltage protection circuit and output voltage protection circuit, which monitors the voltage on the input terminals and the output terminals. If this voltage exceeds the over-voltage set point, the protection circuit will shut down, and enter latch mode. Need to repower input voltage or reset ON/OFF pin voltage to turn on the module.

Over-Temperature Protection

The over-temperature protection consists of circuitry that provides protection from thermal damage. If the temperature exceeds the over-temperature threshold the module will shut down. The module will restart after the temperature is within specification.

Parallel

The modules provide active current sharing mode.

For the active current sharing: it permits maximum 8% output voltage deviation between two modules by connecting the Vout pin and Ishare pin of the parallel module together, the current sharing can be realized automatically.

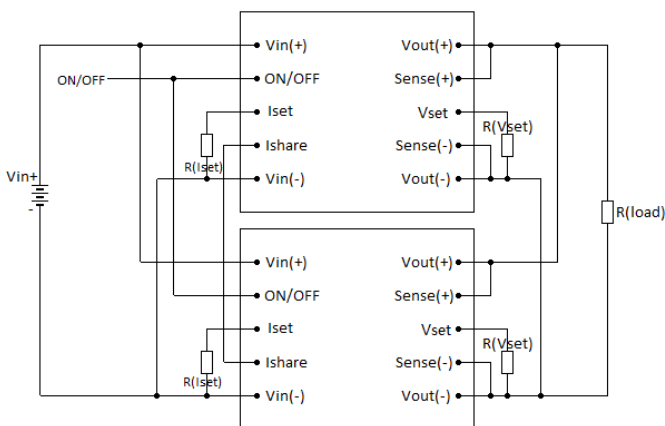

Figure 16: Parallel and current sharing configuration

The module can be parallel directly for higher power without adding external oring-fet. And the failure of a power supply should not affect the load sharing or output voltages of the other supplies still operation

For a normal parallel operation, the following precautions must be observed:

1. The current sharing accuracy equation is:

$$X\% = |I_{o1} - I_{o2}| / I_{rate}$$
 Where,
 - Io1 is the output current of module1;
 - Io2 is the output current of module2
 - Irate is the rated full load current of per module.
2. To ensure a better steady current sharing accuracy, below design guideline should be followed:
 - a) The inputs of the converters must be connected to the same voltage source; and the PCB trace resistance from Input voltage source to Vin+ and Vin- of each converter should be equalized as much as possible.
 - b) The PCB trace resistance from each converter's output to the load should be equalized as much as possible.
 - c) For accurate current sharing accuracy test, the module should be soldered in order to avoid the unbalance of the touch resistance between the modules to the test board.
3. To ensure the parallel module can start up monotonically without triggering the OCP circuit, below design guideline should be followed:
 - a) Before all the parallel modules finished start up, the total load current should be lower than the rated current of 1 module.
 - b) The ON/OFF pin of the converters should be connected together to keep the parallel modules start up at the same time.
 - c) The under voltage lockout point will slightly vary from unit to unit. The dv/dt of the rising edge of the input source voltage must be greater than 1V/ms to ensure that the parallel module start up at the same time.

Soldering and Cleaning Considerations

Post solder cleaning is usually the final board assembly process before the board or system undergoes electrical testing. Inadequate cleaning and/or drying may lower the reliability of a power module and severely affect the finished circuit board assembly test. Adequate cleaning and/or drying is especially important for un-encapsulated and/or open frame type power modules. For assistance on appropriate soldering and cleaning procedures, please contact Delta's technical support team.

Synchronization

The module has no synchronization function in default, Leave this pin floating or tie it directly to Vout-. If used, please contact with Delta sales/FAE for this function.

PMBus Communication

The module has a digital PMBus interface to allow the module to be monitored, controlled and configured by the system. The module supports 3 PMBus signal lines, Data, Clock, SMBALERT (optional), and 2 Address line Addr0 and Addr1. More detail PMBus information can be found in the PMB Power Management Protocol Specification, Part I and part II, revision 1.2; which is shown in <http://pmbus.org>. Both 100kHz and 400kHz bus speeds are supported by the module. Connection for the PMBus interface should be following the High Power DC specifications given in section 3.1.3 in the SMBus specification V2.0 or the Low Power DC specifications in section 3.1.2. The complete SMBus specification is shown in <http://smbus.org>.

The module supports the Packet Error Checking (PEC) protocol. It can check the PEC byte provided by the PMBus master, and include a PEC byte in all message responses to the master.

SMBALERT protocol is also supported by the module. SMBALERT line is also a wired-AND signal; by which the module can alert the PMBUS master via pulling the SMBALERT pin to an active low. There are two ways that the master and the module response to the alert of SMBALERT line.

One way is for the module used in a system that does not support Alert Response Address (ARA). The module is to retain its resistor programmed address, when it is in an ALERT active condition. The master will communicate with the slave module using the programmed address, and using the various READ_STATUS commands to find who cause for the SMBALERT. The CLEAR_FAULTS command will clear the SMBALERT.

The module contains a data flash used to store configuration settings, which will not be programmed into the device data flash automatically. The STORE_DEFAULT_ALL command must be used to commit the current settings are transfer from RAM to data flash as device defaults

PMBUS Addressing

The Module has flexible PMBUS addressing capability. When connect different resistor from Addr0 and Addr1 pin to GND pin, 64 possible addresses can be acquired. The address is in the form of octal digits; Each pin offers one octal digit, and then combine together to form the decimal address as shown in below.

$$\text{Address} = 8 * \text{ADDR1} + \text{ADDR0}$$

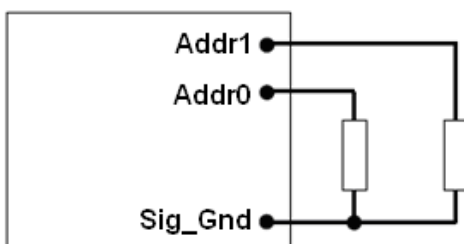

Corresponded to each octal digit, the requested resistor values are shown in below, and +/-1% resistors accuracy can be accepted. If there are any resistances exceeding the requested range, address 127 will be return. 0-12 and 40, 44, 45, and 55 in decimal address can't be used, since they are reserved according to the SMBus specifications, and which will also return address 127. The address resistance will be considered as 200k if resistor $\geq 200k$.

Octal digit	Resistor(Kohm)
0	10
1	15.4
2	23.7
3	36.5
4	54.9
5	84.5
6	130
7	200

PMBus Data Format

The module receives and report date in LINEAR format. altering the exponent is supported. DIRECT format is not supported by the module.

For commands that set or report any voltage thresholds related to the output voltage, the module supports the linear data format consisting of a two-byte value with a 16-bit, unsigned mantissa, and a fixed exponent of -9. The format of the two data bytes is shown below:

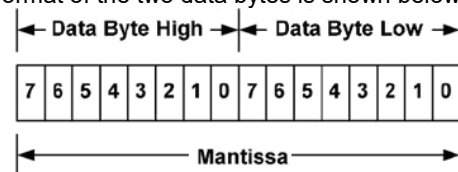

The equation can be written as:

$$V_{out} = \text{Mantissa} \times 2^{-9}$$

For example, considering set V_{out} to 12V by VOUT_COMMAND, the read/write data can be calculated refer to below process:

1. Mantissa = $V_{out}/2^{-9} = 12/2^{-9} = 6144$;
2. Converter the calculated Mantissa to hexadecimal 0x1800.

For commands that set including input voltages, output current, temperature, time and frequency, the format of the two data bytes is shown as in below:

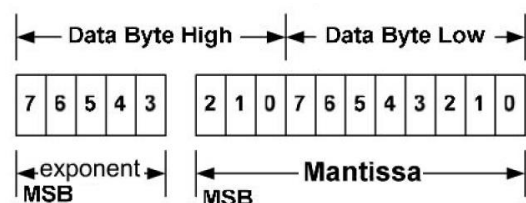

For example, considering set the turn on threshold of input under voltage lockout to 34V by VIN_ON command; the read/write data can be calculated refer to below process:

1. The read V_{in} value is hexadecimal E910
2. The high 5 bit in binary is 11101, so the Mantissa is 2^{-3} .
3. Low 11 bits 00100010000, in decimal is 272
4. So the real V_{in} value is 272×2^{-3} is 34V.

Supported PMBus Commands

The main PMBus commands described in the PMBus 1.2 specification are supported by the module. Partial PMBus commands are fully supported; Partial PMBus commands have difference with the definition in PMBus 1.2 specification. All the supported PMBus commands are detail summarized in below table.

Command	Code	Description	Type	Compatible with standard PMBUS or not?	Data Format	Default value	Range limit	Data units	Exponent	Note
OPERATION	0x01	Turn the module on or off by PMBUS command	R/W byte	Refer to below description	Bit field	0x80	/	/	/	/
ON_OFF_CONFIG	0x02	Configures the combination of primary on/off pin and PMBUS command	R/W byte	Not support turn off delay and fall time setup	Bit field	0x1D	/	/	/	0x1D (Neg Logic); 0x1F (Pos Logic);
CLEAR_FAULTS	0x03	Clear any fault bits that have been set	Send byte	Yes	/	/	/	/	/	/
WRITE_PROTECTION	0x10	Set or Clear the bit of Write protection	R/W byte	Yes	/	0x80	/	/	/	
STORE_DEFAULT_ALL	0x11	Stores operating parameters from RAM to data flash	Send byte	Yes	/	/	/	/	/	This command is effective to the parameter of all command in the table.
VOUT_MODE	0x20	To read Vo data format	Read byte	Yes	mode+exp	0x17	/	/	/	/
VOUT_COMMAND	0x21	To Set Output Vo target	R/W word	YES	Vout Linear	Vset pin config	0~65	V	-9	/
OT_FAULT_LIMIT	0x4F	Set the over temperature fault threshold.	R/W word	Yes	TEMP Linear	130	125~140	Deg. C		Must be greater than OT_WARN_LIMIT value
VIN_OV_FAULT_LIMIT	0x55	Set the input overvoltage fault threshold.	R/W word	Yes	Vin Linear	63	1~64	V		
STATUS_WORD	0x79	Returns the information with a summary of the module's fault/warning	Read word	Refer to below description	Bit field	/	/	/	/	/
STATUS_VOUT	0x7A	Returns the information of the module's output voltage related fault/warning	R/W byte	Refer to below description;	Bit field	/	/	/	/	/
STATUS_IOUT	0x7B	Returns the information of the module's output current related fault/warning	R/W byte	Refer to below description	Bit field	/	/	/	/	/
STATUS_INPUT	0x7C	Returns the information of the module's input over voltage and under voltage fault	R/W byte	Refer to below description	Bit field	/	/	/	/	/
STATUS_TEMPERATURE	0x7D	Returns the information of the module's temperature related fault/warning	R/W byte	Refer to below description;	Bit field	/	/	/	/	/
STATUS_CML	0x7E	Returns the information of the module's communication related faults.	R/W byte	Refer to below description	Bit field	/	/	/	/	/
READ_VIN	0x88	Returns the input voltage of the module	Read word	Yes	Vin Linear	/	/	Volts	/	/
READ_VOUT	0x8B	Returns the output voltage of the module	Read word	Yes	Vout Linear	/	/	Volts	/	/
READ_IOUT	0x8C	Returns the output current of the module	Read word	Yes	Iout Linear	/	/	Amps	/	/
READ_TEMPERATURE_1	0x8D	Returns the module's hot spot temperature of the module	Read word	Yes	TEMP Linear	/	/	Deg. C	/	/
READ_TEMPERATURE_2	0x8E	Returns the module's hot spot temperature of the module	Read word	Yes	TEMP Linear	/	/	Deg. C	/	/
PMBUS_REVISION	0x98	Reads the revision of the PMBus	Read byte	Yes	Bit field	22	/	/	/	/

Command	Code	Description	Type	Compatible with standard PMBUS or not?	Data Format	Default value	Range limit	Data units	Exponent	Note
VO_MODE_SET	0XD0	Set Vo target method, pmbus set or Vset-pin.	R/W byte	Refer to below description	Bit field	00	/	/	/	/
IO_MODE_SET	0XD1	Set OCP-Point method, pmbus set or Iset-pin	R/W byte	Refer to below description	Bit field	00	/	/	/	/
IO_LIMIT_TARGET	0XD2	Set OCP-Point by, pmbus	R/W word	N	Linear	Iset pin config	1~50	A	/	/

Note:
3): The default OVP value for PMbus is invalid. It needs to be enabled by PMbus.

OPERATION [0x01]

Bit number	Purpose	Bit Value	Meaning	Default Settings, 0x80
7:	Enable/Disable the module	1	Output is enabled	1
		0	Output is disabled	
6:0	Reserved			0000000

ON_OFF_CONFIG [0x02]

Bit number	Purpose	Bit Value	Meaning	Default Settings, 0x1D (negative) /0x1F (positive)
7:5	Reserved			000
4	Controls how the unit responds to the primary on/off pin and the OPERATION command;	1	Module does not power up until commanded by the primary ON/OFF pin and the OPERATION	1
		0	Module power up at any time regardless of the state of the primary ON/OFF pin and the OPERATION	
3	Controls how the unit responds to the OPERATION command	1	Module responds to the 7 bit in the OPERATION	1
		0	Module ignores the 7 bit in the OPERATION	
2	Controls how the unit responds to the primary on/off pin	1	Module requires the primary ON/OFF pin to be asserted to start the unit	1
		0	Module ignores the state of the primary ON/OFF pin	
1	Control logic of primary on/off pin	1	Positive Logic	0, negative; 1, positive.
		0	Negative Logic	
0	Unit turn off delay time control	1	Shut down the module with 0 delay cycle	1

STATUS_WORD [0x79]

High byte

Bit number	Purpose	Bit Value	Meaning
7	An output over voltage fault or warning	1	Occurred
		0	No Occurred
6	An output over current fault or warning	1	Occurred
		0	No Occurred
5	An input voltage fault, including over voltage and under voltage	1	Occurred
		0	No Occurred
4	Reserved		
3	Power_Good	1	is negated
		0	ok
2:0	Reserved		

Low byte

Bit number	Purpose	Bit Value	Meaning
7	Reserved		
6	OFF (The unit is not providing power to the output, regardless of the reason)	1	Occurred
		0	No Occurred
5	An output over voltage fault	1	Occurred
		0	No Occurred
4	An output over current fault	1	Occurred
		0	No Occurred
3	An input under voltage fault	1	Occurred
		0	No Occurred
2	A temperature fault or warning	1	Occurred
		0	No Occurred
1	CML (A communications, memory or logic fault)	1	Occurred
		0	No Occurred
0	Reserved		

STATUS_VOUT [0x7A]

Bit number	Purpose	Bit Value	Meaning
7	Output over voltage fault	1	Occurred
		0	No Occurred
6	Output over voltage warning	1	Occurred
		0	No Occurred
5:0	Reserved		

STATUS_IOUT [0x7B]

Bit number	Purpose	Bit Value	Meaning
7	Output over current fault	1	Occurred
		0	No Occurred
6	Reserved		
5	Output over current warning	1	Occurred
		0	No Occurred
4:0	Reserved		

STATUS_INPUT [0x7C]

Bit number	Purpose	Bit Value	Meaning
7	Input over voltage fault	1	Occurred
		0	No Occurred
6: 5	Reserved		
4	Input under voltage fault	1	Occurred
		0	No Occurred
3:0	Reserved		

STATUS_TEMPERATURE [0x7D]

Bit number	Purpose	Bit Value	Meaning
7	Over temperature fault	1	Occurred
		0	No Occurred
6	Over temperature warning	1	Occurred
		0	No Occurred
5:0	Reserved		

STATUS_CML [0x7E]

Bit number	Purpose	Bit Value	Meaning
7	Invalid/Unsupported Command Received	1	Occurred
		0	No Occurred
6	Invalid/Unsupported Data Received	1	Occurred
		0	No Occurred
5	Packet Error Check Failed	1	Occurred
		0	No Occurred
4:0	Reserved		

VO_MODE_SET [0XD0]

Bit number	Purpose	Bit Value	Meaning	Default Settings, 0x00
0	Set Vo target method, pmbus set or Vset-pin	1	Vo target set by pmbus 0x21 command	0
		0	Vo target set by Vset-pin	
7-1	Reserved			0000000

IO_MODE_SET [0XD1]

Bit number	Purpose	Bit Value	Meaning	Default Settings, 0x00
0	Set OCP-Point method, pmbus set or Iset-pin	1	OCP-Point set by pmbus 0Xd2 command	0
		0	OCP-Point set by Iset-pin	
7-1	Reserved			0000000

Thermal Testing Setup

The following figure shows thermal test setup. The power module is mounted on a 185mmX185mm, 105µm (3Oz), 6 layers' test PWB and attach to a cold plate with thermal interface material (TIM).

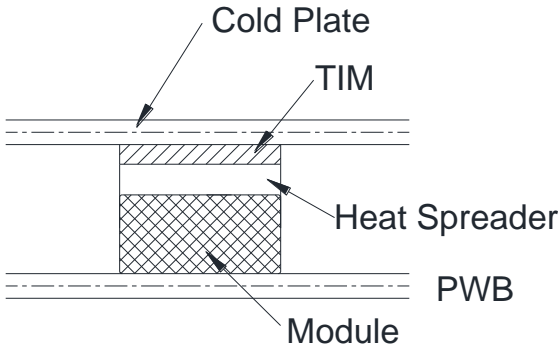

Figure 17: Thermal test setup

Thermal Derating

Heat can be removed by increasing airflow over the module. To enhance system reliability, the power module should always be operated below the maximum operating temperature. If the temperature exceeds the maximum module temperature, reliability of the unit may be affected.

Thermal Curves (With Base-plate and encased)

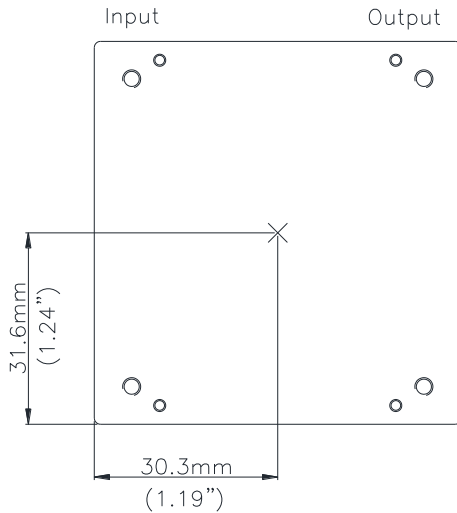

Figure 18: * Hot spot's location on the base plate.

Thermal Curves (With Base-plate and encased)

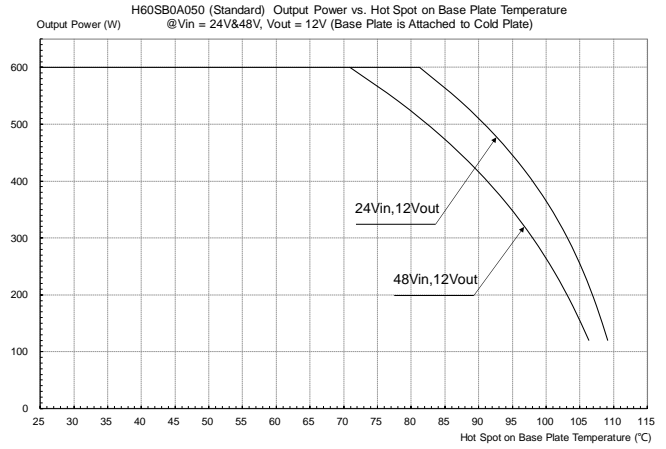

Figure 19: Output power vs. Base plate temperature @ $V_{in}=24V\&48V$, $V_{out}=12V$ (Base plate is attached to cold plate)

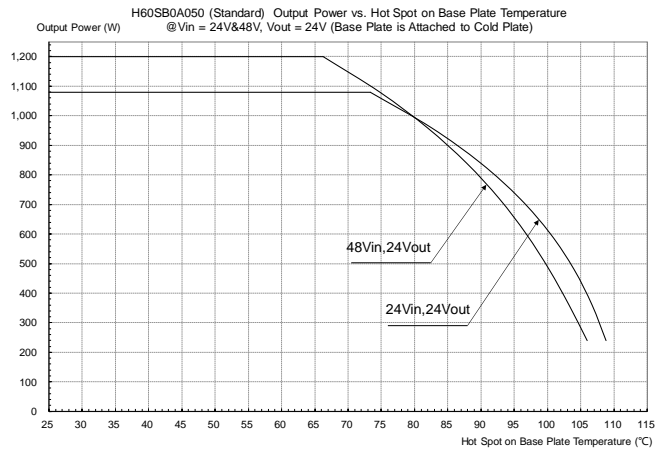

Figure 20: Output power vs. Base plate temperature @ $V_{in}=24V\&48V$, $V_{out}=24V$ (Base plate is attached to cold plate)

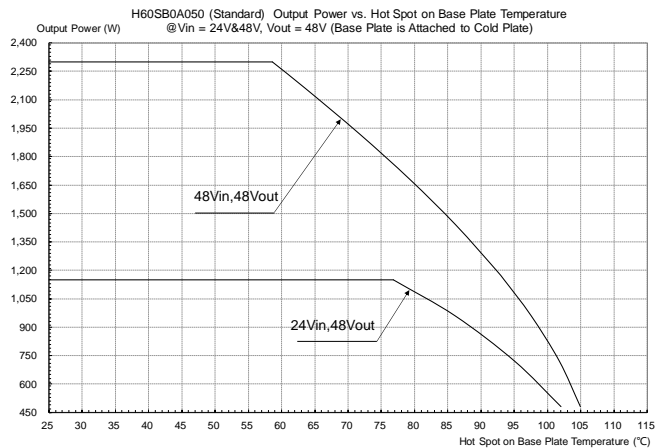
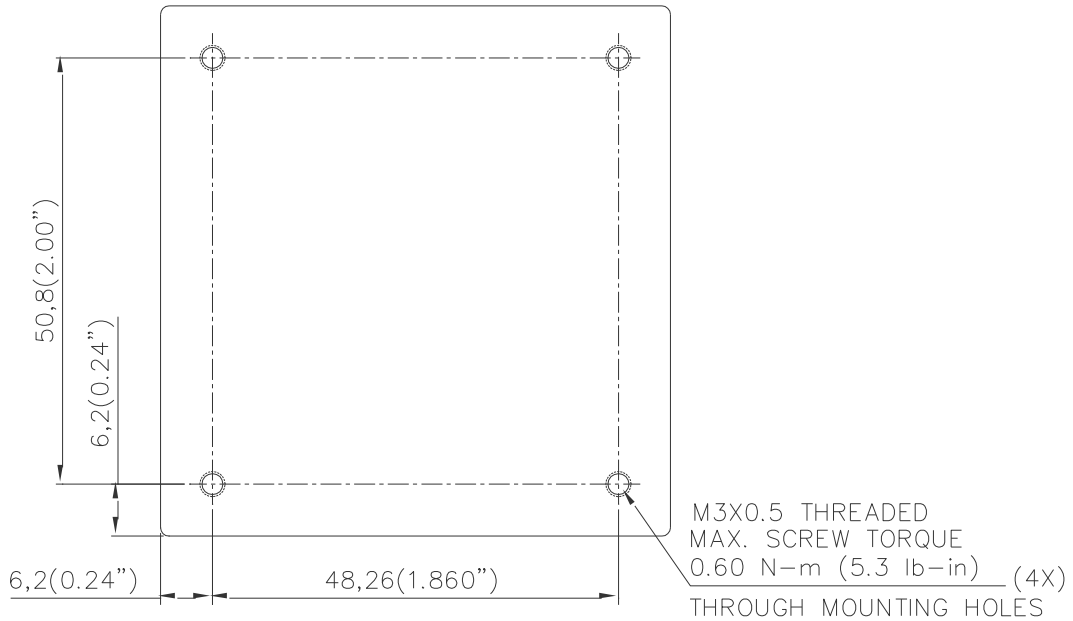
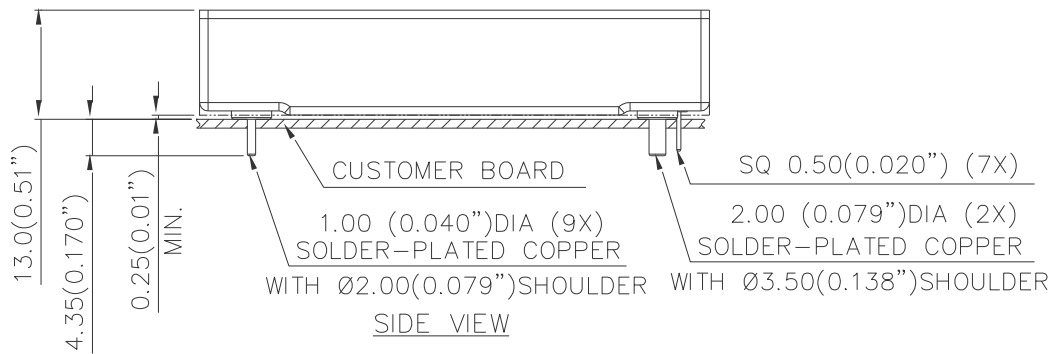

Figure 21: Output power vs. Base plate temperature @ $V_{in}=24V\&48V$, $V_{out}=48V$ (Base plate is attached to cold plate)

Mechanical Drawing (With Baseplate and Encased)



TOP VIEW



SIDE VIEW

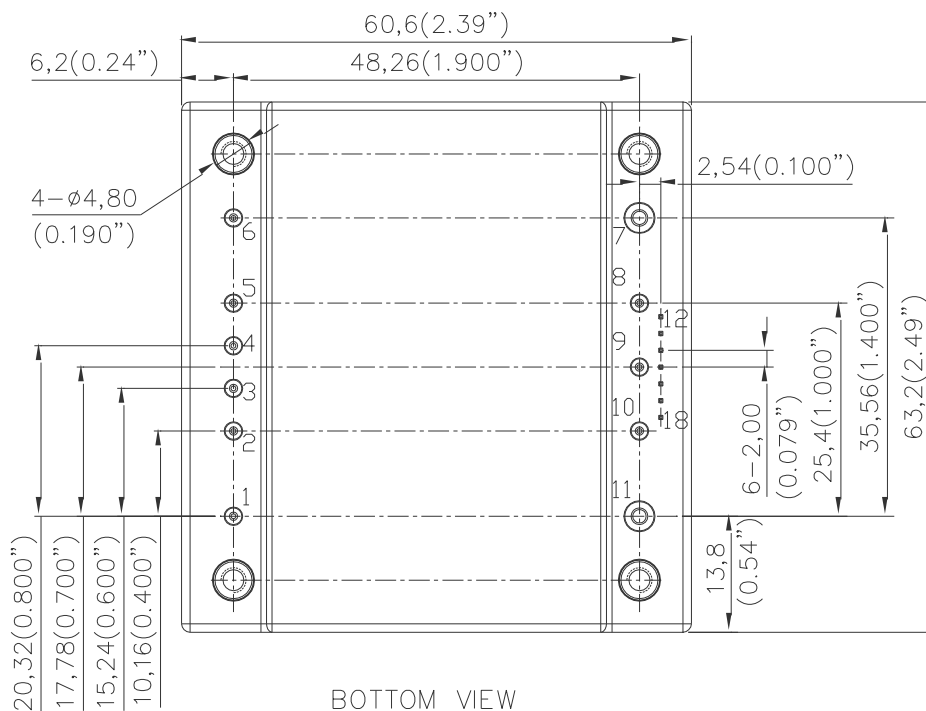

BOTTOM VIEW

Pin No.	Name	Function
1	+Vin	Positive input voltage
2	ON/OFF	Remote ON/OFF
3	SynCln	No function, should be floating or tie it to Vout -
4	Iset	Input to set the maximum output current.
5	Ishare	Input/Output: Current monitor or Current share.
6	-Vin	Negative input voltage
7	-Vout	Negative output voltage
8	-Sense	Negative Power Voltage Sense,
9	Vset	Output voltage set
10	+Sense	Positive Power Voltage Sense
11	+Vout	Positive output voltage
12	C2	Power Good
13	Sig_Gnd	Signal ground
14	Data	PMBus data line
15	SMBAlert	PMBus SMBAlert line
16	Clock	PMBus clock line
17	Addr1	ADDR1 pin sets the high order digit of the address
18	Addr0	ADDR0 pin sets the high order digit of the address

Pin Specification:

Pins 1~6,8~10
Pins 7,11
Pins 12~18

1.00mm (0.040") diameter; copper with matte Tin plating and Nickel under plating
2.00mm (0.079") diameter; copper with matte Tin plating and Nickel under plating
Digital pins; Square 0.50mm (0.020"); copper with golden flash plating

Recommended Pad Layout

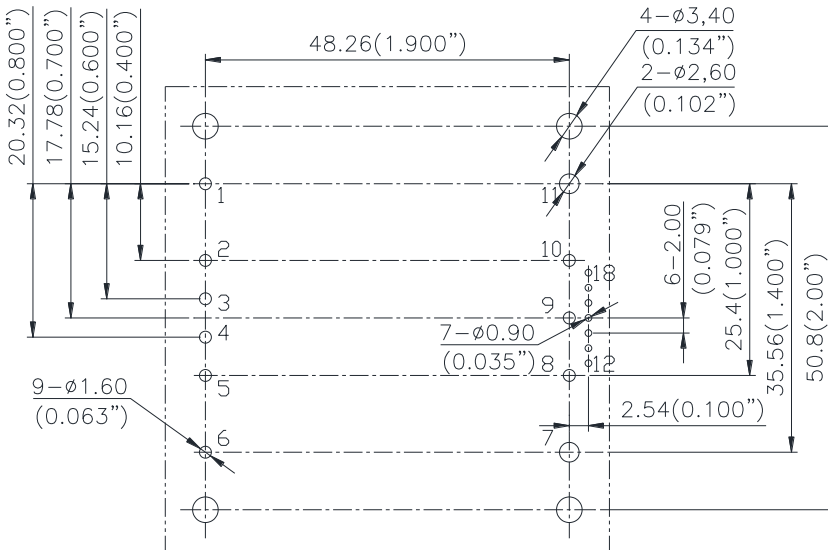

PIN	NAME	PIN	NAME
1	Vin(+)	12	C2
2	ON/OFF	13	Sig-Gnd
3	SynCln	14	Data
4	Iset	15	SMBAlert
5	Ishare	16	Clock
6	Vin(-)	17	Addr1
7	Vout(-)	18	Addr0
8	Sense(-)	Optional: pin12~18	
9	Vset		
10	Sense(+)		
11	Vout(+)		

NOTES:

DIMENSIONS ARE IN MILLIMETERS AND (INCHES)

TOLERANCES: X.Xmm±0.5mm(X.XX in.±0.02 in.)

X.XXmm±0.25mm(X.XXX in.±0.010 in.)

Soldering Method

Generally, as the most common mass soldering method for the solder attachment, wave soldering is used for through-hole power modules and reflow soldering is used for surface-mount ones. Delta recommended soldering methods and process parameters are provided in this document for solder attachment of power modules onto system board. SAC305 is the suggested lead-free solder alloy for all soldering methods.

Wave Soldering (Lead-free)

Delta's power modules are designed to be compatible with single-wave or dual wave soldering. The suggested soldering process must keep the power module's internal temperature below the critical temperature of 217°C continuously. The recommended wave-soldering profile is shown in following figure.

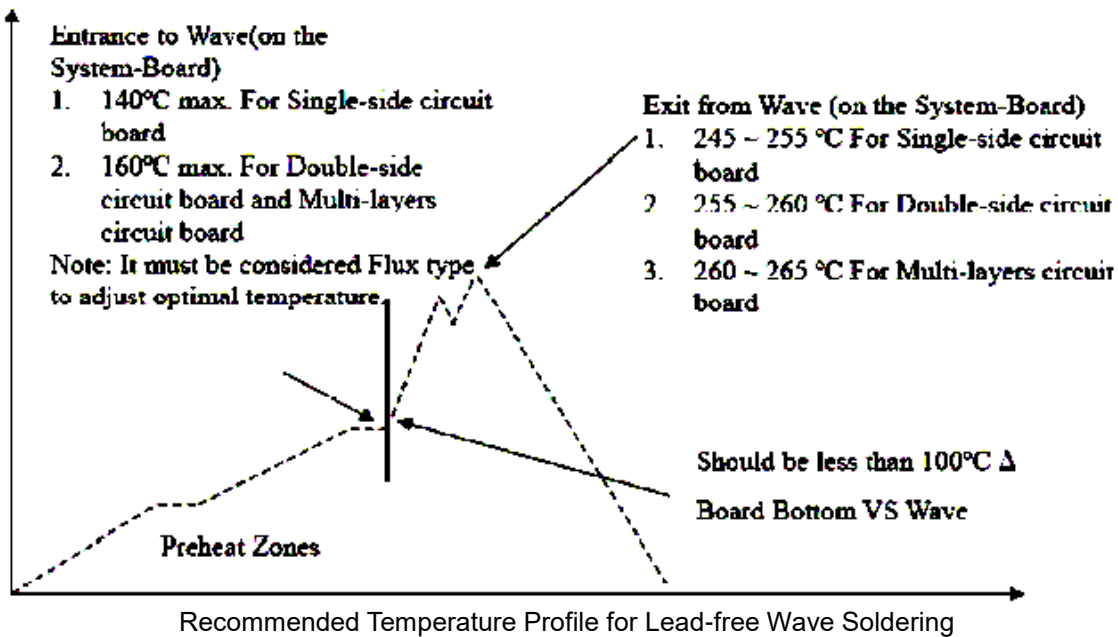

Note: The temperature is measured on solder joint of pins of power module.

The typical recommended (for double-side circuit board) preheat temperature is 115+/-10°C on the top side (component side) of the circuit board. The circuit-board bottom-side preheat temperature is typically recommended to be greater than 135°C and preferably within 100°C of the solder-wave temperature. A maximum recommended preheat up rate is 3°C /s. A maximum recommended solder pot temperature is 255+/-5°C with solder-wave dwell time of 3~6 seconds. The cooling down rate is typically recommended to be 6°C/s maximum.

Hand Soldering (Lead Free)

Hand soldering is the least preferred method because the amount of solder applied, the time the soldering iron is held on the joint, the temperature of the iron, and the temperature of the solder joint are variable. The recommended hand soldering guideline is listed in Table 1. The suggested soldering process must keep the power module's internal temperature below the critical temperature of 217°C continuously.

Table 1 Hand-Soldering Guideline

Parameter	Single-side Circuit Board	Double-side Circuit Board	Multi-layers Circuit Board
Soldering Iron Wattage	90	90	90
Tip Temperature	385+/-10°C	420+/-10°C	420+/-10°C
Soldering Time	2 ~ 6 seconds	4 ~ 10 seconds	4 ~ 10 seconds

PART NUMBERING SYSTEM

H	60	S	B	0A0	50	N	R	D ^{*note}	C
Type of Product	Input Voltage	Number of Outputs	Product Series	Output Voltage	Output Current	ON/OFF Logic	Pin Length /Type	Electrical Option	Mechanical Option
H - Half Brick	60 - 9~60V	S - Single	B - Series number	0A0 - Adjustable	50 -50A	N - Negative	R - 0.170"	D - Digital pins A - Analog pins	C - base plate & encased E- constant frequency, base plate & encased

Note for mechanical pins option:

1. D- Digital pins*: with PMBus pins(pin12~18)
2. A- Analog pins*: without PMBus pins(pin12~18)

RECOMMENDED PART NUMBER.

Model Name	Input	Output	Peak Eff.
H60SB0A050NRDC	9V~60V	Adjustable 50A	98.0%
H60SB0A050NRDE	9V~60V	Adjustable 50A	98.0%

Please contact with Delta sales/FAE for different optional functions.

CONTACT US:

Website: www.deltaww.com/dcdc

Email: dcdc@deltaww.com

USA:

Telephone:
East Coast: 978-656-3993
West Coast: 510-668-5100
Fax: 510-668-0680

Europe:

Telephone: +31-20-800-3900
Fax: +31-20-800-3999

Asia & the rest of world:

Telephone: +886-3-452-6107
Ext. 6221~6226
Fax: +886-3-433-1810

WARRANTY

Delta offers a two (2) year limited warranty. Complete warranty information is listed on our web site or is available upon request from Delta.

Information furnished by Delta is believed to be accurate and reliable. However, no responsibility is assumed by Delta for its use, nor for any infringements of patents or other rights of third parties, which may result from its use. No license is granted by implication or otherwise under any patent or patent rights of Delta. Delta reserves the right to revise these specifications

Looking for pricing, stock, or lifecycle information?

Click below to explore more details on WIN SOURCE:

- ⊖ [View GRM188Z71C225KE43D on WIN SOURCE](#)
- ⊖ [Murata Electronics North America Information](#)

Optimize Your Supply Chain with WIN SOURCE Solutions

- ✓ Global Sourcing Solution
- ✓ Obsolete Management
- ✓ Cost Control Management
- ✓ Shortage Management
- ✓ Alternative Solution
- ✓ Excess Inventory Management