

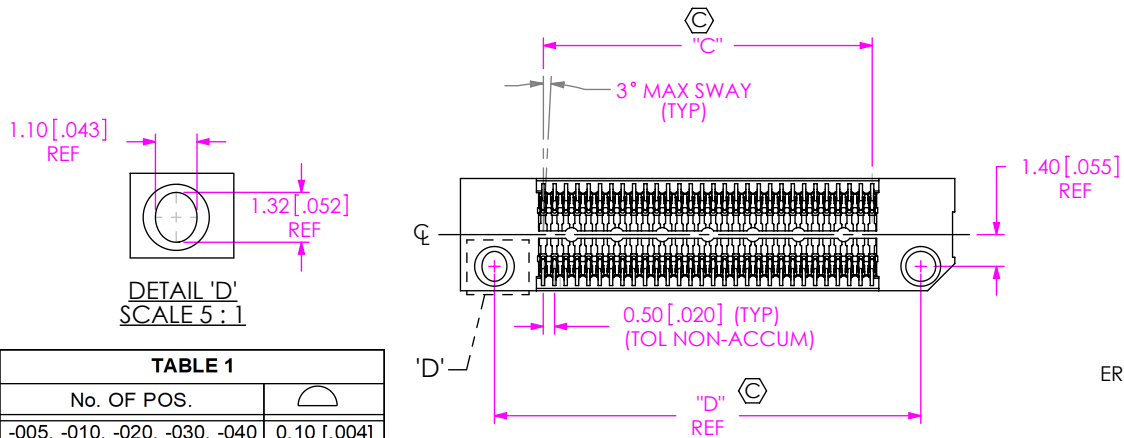

**THE DATASHEET OF
EFR32FG23A020F512GM40-CR**

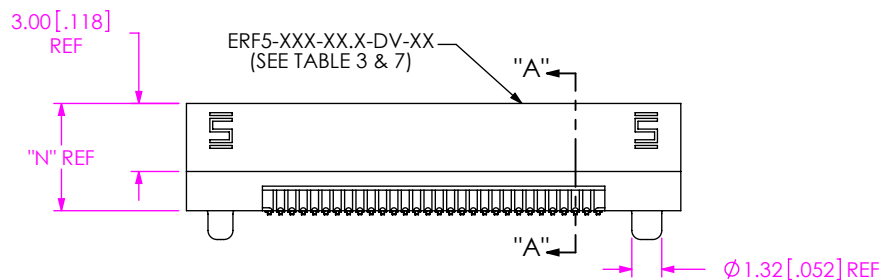

DO NOT
SCALE FROM
THIS PRINT

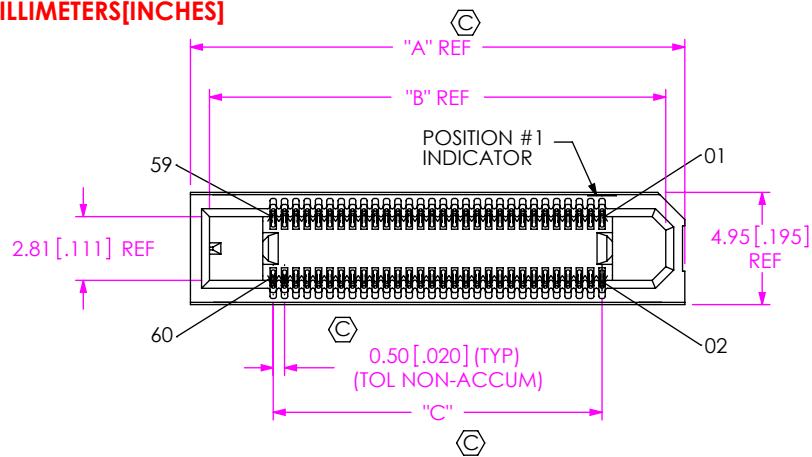

DETAIL 'D'
SCALE 5 : 1

TABLE 1	
No. OF POS.	
-005, -010, -020, -030, -040	0.10 [.004]
-050, -060, -070, -075	0.13 [.005]

NOTES:

- REPRESENTS A CRITICAL DIMENSION.
- MAXIMUM BURR ALLOWANCE: 0.038 [.0015]
- MINIMUM CONTACT PUSHOUT FORCE: 1.6 N [4 LB];
MINIMUM WELD TAB PUSHOUT FORCE: 4.45 N [1 LB];
MINIMUM LATCH PUSHOUT FORCE: 2.25 N [.51 LB].
- ORDERS WILL BE PACKAGED ACCORDING TO THE SAMTEC PACKAGING EFFICIENCY STANDARDS (SPES) FOUND ON WWW.SAMTEC.COM.
- ATTACH LABEL TO EACH REEL.

ERF5-XXX-XX.X-X-DV-XX-X-XR

No OF POSITIONS
(PER ROW)
-005, -010, -020,
-030, -040, -050,
-060, -070, -075

LEAD STYLE
-05.0 = 5MM
-07.0 = 7MM

PLATING SPECIFICATION
-L: 10µ" SELECTIVE GOLD IN
CONTACT AREA, MATTE TIN TAIL
-S: 30µ" SELECTIVE GOLD IN
CONTACT AREA, MATTE TIN TAIL

ROW SPECIFICATION
-DV: DOUBLE VERTICAL

TAPE & REEL (SEE NOTES 4 & 5)
-TR: TAPE & REEL
-FR: FULL REEL QTY TAPE & REEL

PICK & PLACE OPTION
-K: POLYIMIDE FILM

OPTION
-FL: FRICTION LOCK (OPTION
INCLUDES A WELD TAB
(ONLY AVAILABLE UP TO 30 POSITIONS)
(FOR MATING WITH ERM5...DV...-FL)
-WT: WELD TAB
-L: LATCH (NOT AVAILABLE WITH
-FL OR -WT OPTIONS)
(ONLY AVAILABLE WITH
-020, -030, & -040 POSITIONS
AND -05.0 LEAD STYLE)

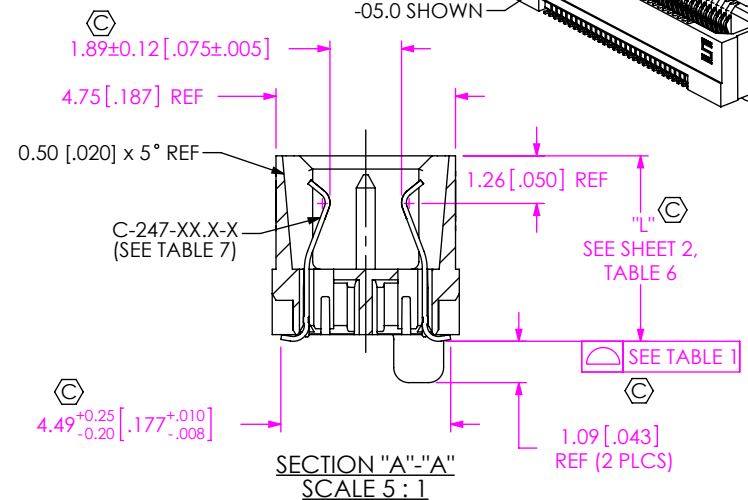
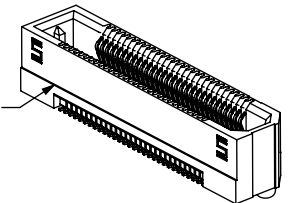

FIG 1
ERF5-030-05.0-X-DV-XX-XR SHOWN

TABLE 2 (REF)			
STACK HEIGHT			
ERF5 LEAD STYLE	ERM5 LEAD STYLE		
		-02.0	-04.0
-05.0	7.0MM	9.0MM	10.0MM
-07.0	9.0MM	11.0MM	12.0MM

F:\DWG\MISC\MKTG\ERF5-XXX-XX.X-X-DV-XX-X-XR-MKT.SLDDRW

UNLESS OTHERWISE SPECIFIED,
DIMENSIONS ARE IN
MILLIMETERS [INCHES].
TOLERANCES ARE:
DECIMALS ANGLES
X.X: ±0.3 [.01] 2°
X.XX: ±0.13 [.005]
X.XXX: ±0.050 [.0020]

PROPRIETARY NOTE
THIS DOCUMENT CONTAINS CONFIDENTIAL AND
PROPRIETARY INFORMATION AND ALL DESIGN,
MANUFACTURING, REPRODUCTION, USE, PATENT RIGHTS
AND SALES RIGHTS ARE EXPRESSLY RESERVED BY SAMTEC,
INC. THIS DOCUMENT SHALL NOT BE DISCLOSED, IN WHOLE
OR PART, TO ANY UNAUTHORIZED PERSON OR ENTITY NOR
REPRODUCED, TRANSFERRED OR INCORPORATED IN ANY
OTHER PROJECT IN ANY MANNER WITHOUT THE EXPRESS
WRITTEN CONSENT OF SAMTEC, INC.

MATERIAL: DO NOT SCALE DRAWING SHEET SCALE: 2:1
INSULATOR: LCP, COLOR: BLACK
CONTACT: BeCu

DESCRIPTION:
0.5MM EDGE RATE SOCKET ASSEMBLY
DWG. NO.
ERF5-XXX-XX.X-X-DV-XX-X-XR
BY: CLAY W 09-23-2010 SHEET 1 OF 4



520 PARK EAST BLVD. NEW ALBANY, IN 47150
PHONE: 812-944-6733 FAX: 812-948-5047
e-Mail: info@SAMTEC.com code 55322

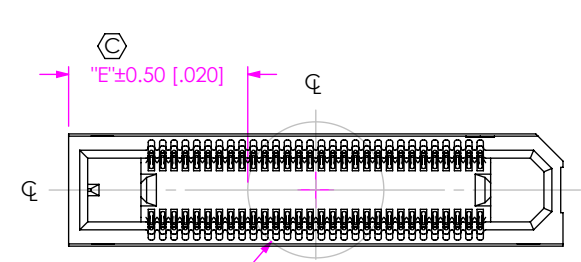

FIG 2
-K OPTION
(USE K-DOT-.236-.343-.005)
ERF5-030-05.0-X-DV-K-XR SHOWN
Ø6.00[.236] REF

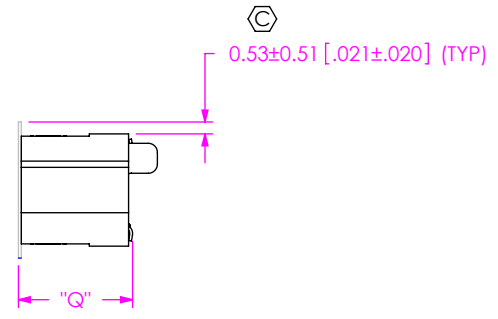
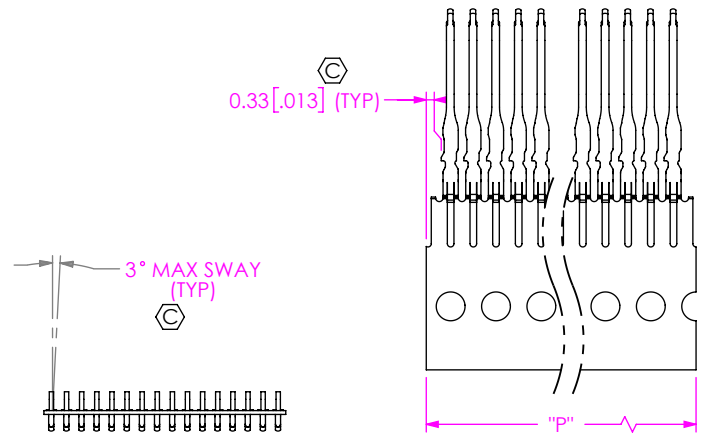

TABLE 6

LEAD STYLE	"Q"	"L"	"N"
-.05.0	5.03 [0.198]	4.91 [0.193]	4.73 [0.186]
-.07.0	7.03 [0.277]	6.91 [0.272]	6.73 [0.265]



IN PROCESS 1
CUT C-247-XX.X-X CONTACT COMBS
(ALL TAILS SAME DIRECTION)

TABLE 8

POSITION	"P"
-005	3.00 [0.118]
-010	5.50 [0.216]
-020	10.50 [0.413]
-030	15.50 [0.610]
-040	20.50 [0.807]
-050	25.50 [1.004]
-060	30.50 [1.201]
-070	35.50 [1.398]
-075	38.00 [1.496]

TABLE 3

POSITION	"A"	"B"	"C"	"D"
-005	9.30 [0.366]	7.62 [0.300]	2.00 [0.079]	6.30 [0.248]
-010	11.80 [0.465]	10.12 [0.398]	4.50 [0.177]	8.80 [0.346]
-020	16.80 [0.661]	15.12 [0.595]	9.50 [0.374]	13.80 [0.543]
-030	21.80 [0.858]	20.12 [0.792]	14.50 [0.571]	18.80 [0.740]
-040	26.80 [1.055]	25.12 [0.989]	19.50 [0.768]	23.80 [0.937]
-050	31.80 [1.252]	30.12 [1.186]	24.50 [0.965]	28.80 [1.134]
-060	36.80 [1.449]	35.12 [1.383]	29.50 [1.161]	33.80 [1.331]
-070	41.80 [1.646]	40.12 [1.580]	34.50 [1.358]	38.80 [1.528]
-075	44.30 [1.744]	42.62 [1.678]	37.00 [1.457]	41.30 [1.626]

TABLE 9

POSITION	"E"					
	-K		-K-WT		-K-FL	
-005	1.65	[0.065]	3.15	[0.124]	3.15	[0.124]
-010	2.90	[0.114]	4.40	[0.173]	4.40	[0.173]
-020	5.40	[0.213]	6.90	[0.271]	6.90	[0.271]
-030	7.90	[0.311]	9.40	[0.370]	9.40	[0.370]
-040	10.40	[0.409]	11.90	[0.469]		
-050	12.90	[0.508]	14.40	[0.567]		
-060	15.40	[0.606]	16.90	[0.665]		
-070	17.90	[0.705]	19.40	[0.764]		
-075	19.15	[0.754]	20.65	[0.813]		

F:\DWG\MISC\MKTG\ERF5-XXX-XX.X-X-DV-XX-X-XR-MKT.SLDDRW

PROPRIETARY NOTE
THIS DOCUMENT CONTAINS CONFIDENTIAL AND PROPRIETARY INFORMATION AND ALL DESIGN, MANUFACTURING, REPRODUCTION, USE, PATENT RIGHTS AND SALES RIGHTS ARE EXPRESSLY RESERVED BY SAMTEC, INC. THIS DOCUMENT SHALL NOT BE DISCLOSED, IN WHOLE OR PART, TO ANY UNAUTHORIZED PERSON OR ENTITY NOR REPRODUCED, TRANSFERRED OR INCORPORATED IN ANY OTHER PROJECT IN ANY MANNER WITHOUT THE EXPRESS WRITTEN CONSENT OF SAMTEC, INC.

DO NOT SCALE DRAWING

SHEET SCALE: 2:1

520 PARK EAST BLVD. NEW ALBANY, IN 47150
PHONE: 812-944-6733 FAX: 812-948-5047
e-Mail info@SAMTEC.com code 55322

DESCRIPTION:
0.5MM EDGE RATE SOCKET ASSEMBLY

DWG. NO.
ERF5-XXX-XX.X-X-DV-XX-X-XR

BY: CLAY W 09-23-2010 SHEET 2 OF 4

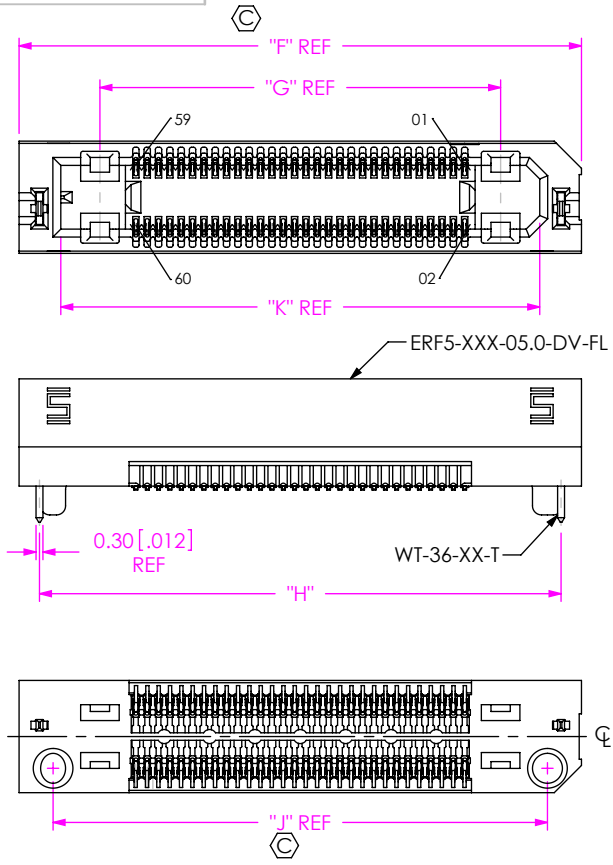

FIG 3
ERF5-030-05.0-X-DV-FL-XR SHOWN
(SAME AS FIG 1 EXCEPT AS SHOWN)
(OPTION INCLUDES A WELD TAB, ONLY AVAILABLE UP TO 30 POSITIONS)

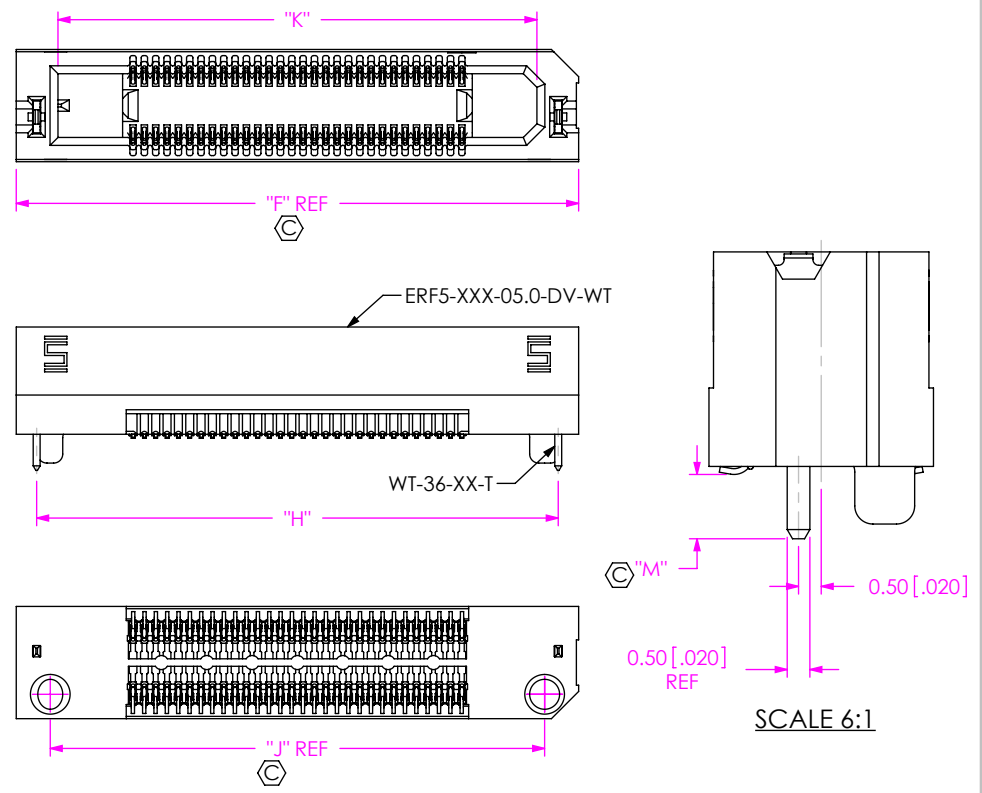

FIG 4
ERF5-030-05.0-X-DV-WT-XR SHOWN
(SAME AS FIG 3 EXCEPT AS SHOWN)

LEAD STYLE	ERF5-XXX-XX.X-DV-XX	C-247-XX.X-X	WT-36-XX-T	"M"
-05.0	ERF5-XXX-05.0-DV-XX	C-247-05.0-X	WT-36-01-T	1.42 [0.056]
-07.0	ERF5-XXX-07.0-DV-XX	C-247-07.0-X	WT-36-03-T	1.27 [0.050]

POSITION	"F"	"G"	"H"	"J"	"K"
-005	12.30 [0.484]	5.17 [0.204]	10.50 [0.413]	9.30 [0.366]	8.62[0.340]
-010	14.80 [0.583]	7.67 [0.302]	13.00 [0.512]	11.80 [0.465]	11.12[0.438]
-020	19.80 [0.780]	12.67 [0.499]	18.00 [0.709]	16.80 [0.661]	16.12[0.635]
-030	24.80 [0.976]	17.67 [0.696]	23.00 [0.906]	21.80 [0.858]	21.12[0.831]
-040	29.80 [1.173]	22.67 [0.893]	28.00 [1.102]	26.80 [1.055]	26.12[1.028]
-050	34.80 [1.370]	27.67 [1.089]	33.00 [1.299]	31.80 [1.252]	31.12[1.225]
-060	39.80 [1.567]	32.67 [1.286]	38.00 [1.496]	36.80 [1.449]	36.12[1.422]
-070	44.80 [1.764]	37.67 [1.483]	43.00 [1.693]	41.80 [1.646]	41.12[1.619]
-075	47.30 [1.862]	40.17 [1.581]	45.50 [1.791]	44.30 [1.744]	43.62[1.717]

PROPRIETARY NOTE
THIS DOCUMENT CONTAINS CONFIDENTIAL AND PROPRIETARY INFORMATION AND ALL DESIGN, MANUFACTURING, REPRODUCTION, USE, PATENT RIGHTS AND SALES RIGHTS ARE EXPRESSLY RESERVED BY SAMTEC, INC. THIS DOCUMENT SHALL NOT BE DISCLOSED, IN WHOLE OR PART, TO ANY UNAUTHORIZED PERSON OR ENTITY NOR REPRODUCED, TRANSFERRED OR INCORPORATED IN ANY OTHER PROJECT IN ANY MANNER WITHOUT THE EXPRESS WRITTEN CONSENT OF SAMTEC, INC.

DO NOT SCALE DRAWING

SHEET SCALE: 2:1



520 PARK EAST BLVD. NEW ALBANY, IN 47150
PHONE: 812-944-6733 FAX: 812-948-5047
e-Mail info@SAMTEC.com code 55322

DESCRIPTION:
0.5MM EDGE RATE SOCKET ASSEMBLY

DWG. NO.
ERF5-XXX-XX.X-X-DV-XX-XR

BY: CLAY W 09-23-2010 SHEET 3 OF 4

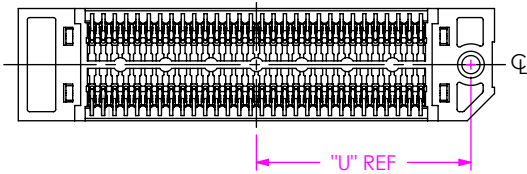
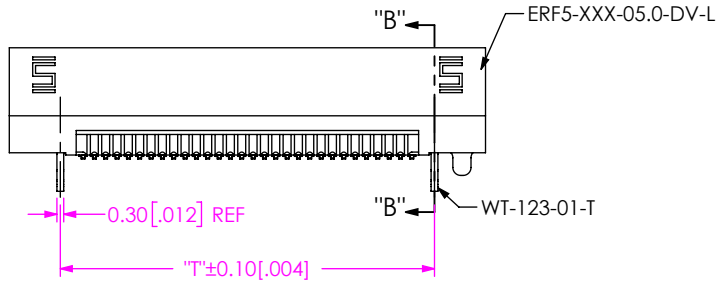
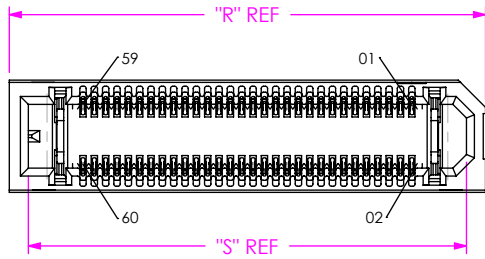
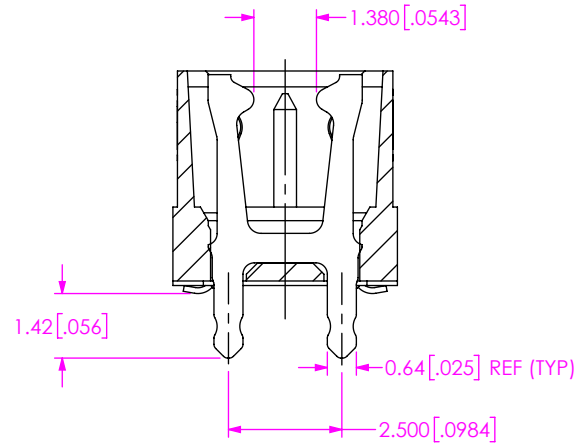

FIG 5
ERF5-030-05.0-X-DV-L-XR SHOWN
(SAME AS FIG 1 EXCEPT AS SHOWN)



SECTION "B"- "B"
SCALE 6 : 1

TABLE 5				
POSITION	"R"	"S"	"T"	"U"
-020	16.00 [0.630]	14.32 [0.564]	11.500 [0.4528]	6.96 [0.274]
-030	21.00 [0.827]	19.32 [0.761]	16.500 [0.6496]	9.46 [0.372]
-040	26.00 [1.024]	24.32 [0.957]	21.500 [0.8465]	11.96 [0.471]

PROPRIETARY NOTE
THIS DOCUMENT CONTAINS CONFIDENTIAL AND PROPRIETARY INFORMATION AND ALL DESIGN, MANUFACTURING, REPRODUCTION, USE, PATENT RIGHTS AND SALES RIGHTS ARE EXPRESSLY RESERVED BY SAMTEC, INC. THIS DOCUMENT SHALL NOT BE DISCLOSED, IN WHOLE OR PART, TO ANY UNAUTHORIZED PERSON OR ENTITY NOR REPRODUCED, TRANSFERRED OR INCORPORATED IN ANY OTHER PROJECT IN ANY MANNER WITHOUT THE EXPRESS WRITTEN CONSENT OF SAMTEC, INC.

DO NOT SCALE DRAWING

SHEET SCALE: 2:1



520 PARK EAST BLVD, NEW ALBANY, IN 47150
PHONE: 812-944-6733 FAX: 812-948-5047
e-Mail info@SAMTEC.com code 55322

DESCRIPTION:
0.5MM EDGE RATE SOCKET ASSEMBLY

DWG. NO.
ERF5-XXX-XX.X-X-DV-XX-X-XR

BY: CLAY W 09-23-2010 SHEET 4 OF 4

Looking for pricing, stock, or lifecycle information?

Click below to explore more details on WIN SOURCE:

- ⊖ [View EFR32FG23A020F512GM40-CR on WIN SOURCE](#)
- ⊖ [Silicon Labs Information](#)

Optimize Your Supply Chain with WIN SOURCE Solutions

- ✓ Global Sourcing Solution
- ✓ Obsolete Management
- ✓ Cost Control Management
- ✓ Shortage Management
- ✓ Alternative Solution
- ✓ Excess Inventory Management