

Description

The AP7583Q/AQ series are 300mA LDO for automotive battery-powered applications. The AP7583Q features 2.5µA quiescent current at light loads. Therefore, the AP7583Q/AQ are suitable solution to supply always-power-on components, such as microcontroller (MCUs) and controller area network (CAN) transceivers.

The AP7583Q/AQ have features of wide input-voltage range, high accuracy, low dropout voltage, current limit and ultra-low quiescent current, which make it ideal for automotive applications. The AP7583AQ has power-good indicator.

The IC consists of a voltage reference, an error amplifier, a resistor network for setting output voltage, a current-limit circuit for current protection, and a chip-enable circuit.

The AP7583Q/AQ both have 3.3V and 5V fixed output-voltage version, and adjustable version.

The AP7583Q/AQ are available in the MSOP-8EP, W-DFN2020-6 (SWP) (Type A1) and TO252-4 (Type C).

Features

- Wide Input-Voltage Range: 3V to 42V
- Maximum Output Current: 300mA
- Low Dropout Voltage: $V_{DROP} = 320\text{mV} @ I_{OUT} = 300\text{mA}$ (typ)
- Low Quiescent Current:
 - AP7583Q is 2.5µA (typ)
 - AP7583AQ is 3µA (typ)
- High Output-Voltage Accuracy: $\pm 1.5\%$
- Compatible with Low ESR Ceramic Capacitor
- Excellent Line/Load Regulation
- Thermal Shutdown Function
- Short Current Protection Function
- Output Current Limit
- AP7583AQ with Power-Good (PG) Output for Supply Monitoring and for Sequencing of Other Supplies
- **The AP7583Q/AQ are suitable for automotive applications requiring specific change control; these parts are AEC-Q100 qualified, PPAP capable, and manufactured in IATF16949 certified facilities.**

<https://www.diodes.com/quality/product-definitions/>

Applications

- Powering MCUs and CAN/LIN transceivers
- Automotive head units
- EV and HEV battery management systems
- Body control modules
- Transmission control units (TCU)

Notes: 1. No purposely added lead. Fully EU Directive 2002/95/EC (RoHS), 2011/65/EU (RoHS 2) & 2015/863/EU (RoHS 3) compliant.
 2. See <https://www.diodes.com/quality/lead-free/> for more information about Diodes Incorporated's definitions of Halogen- and Antimony-free, "Green" and Lead-free.
 3. Halogen- and Antimony-free "Green" products are defined as those which contain <900ppm bromine, <900ppm chlorine (<1500ppm total Br + Cl) and <1000ppm antimony compounds.

Pin Assignments

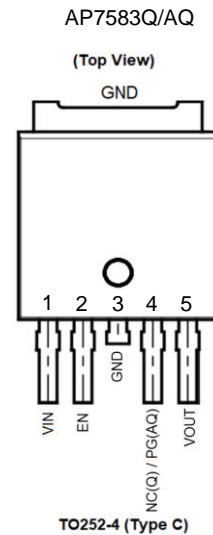
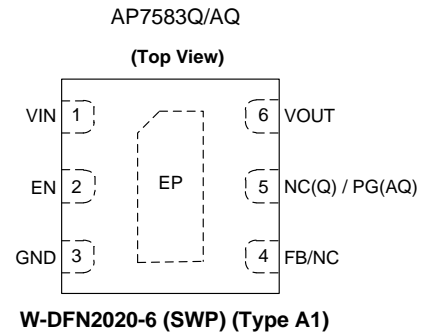
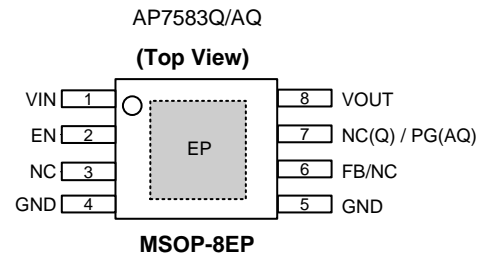

Typical Applications Circuit

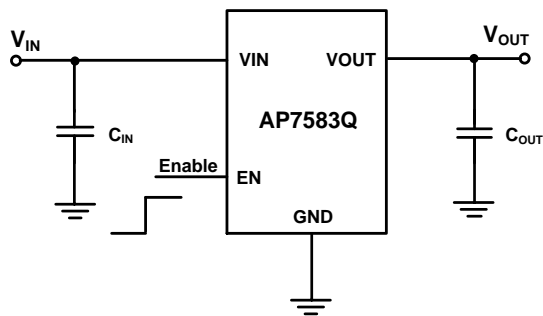

AP7583Q Fixed Version

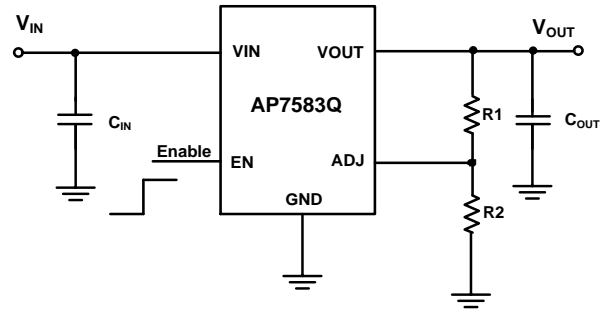

AP7583Q Adjustable Output

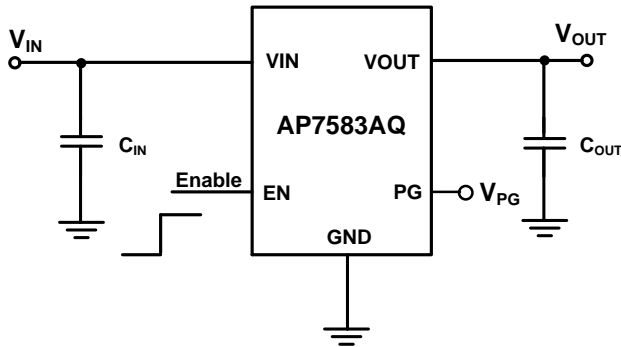

AP7583AQ Fixed Version

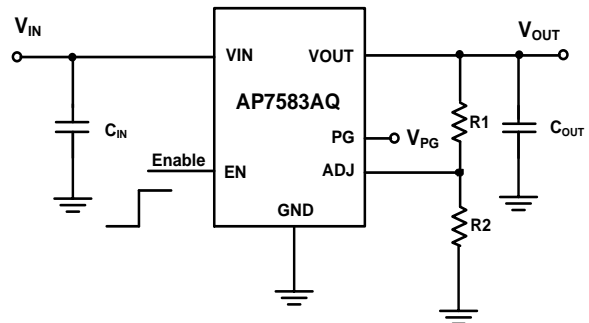

AP7583AQ Adjustable Output

Pin Descriptions

Pin Number (AP7583Q/AQ)			Pin Name	Function
MSOP-8EP	W-DFN2020-6 (SWP) (Type A1)	TO252-4 (Type C)		
1	1	1	VIN	Input voltage
2	2	2	EN	Enable input, active high
3, 7(Q)	5(Q)	4(Q)	NC	Not connected internally. Recommend connection to GND to maximize PCB copper for thermal dissipation.
7(AQ)	5(AQ)	4(AQ)	PG	Power-good pin with one internal pull high resistor. When the V _{OUT} is below the PG threshold, the PG pin is driven low; when the V _{OUT} exceeds the threshold, the PG pin goes into a high-impedance state.
4, 5	3	3	GND	Ground
6	4	—	FB/NC	Adjustable voltage version only – a resistor divider from this pin to the OUT pin and ground sets the output voltage.
8	6	5	VOUT	Regulated output voltage
EP	EP	—	Exposed Pad	In PCB layout, prefer to use large copper area to cover this pad for better thermal dissipation, then connect this area to GND or leave it open. However, do not use it as GND electrode function alone.

Functional Block Diagram

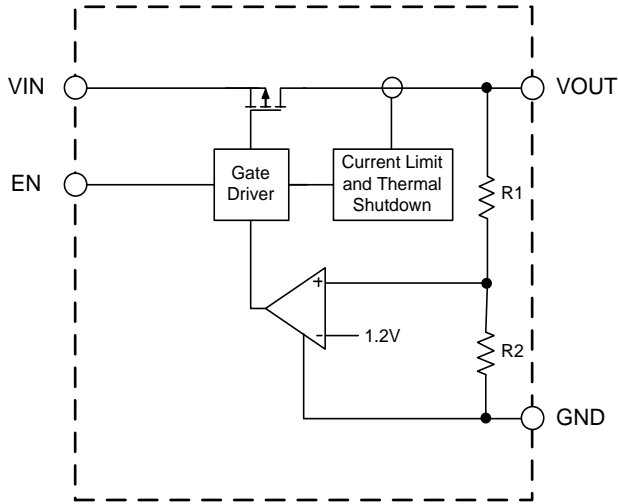

AP7583Q Fixed Version with EN

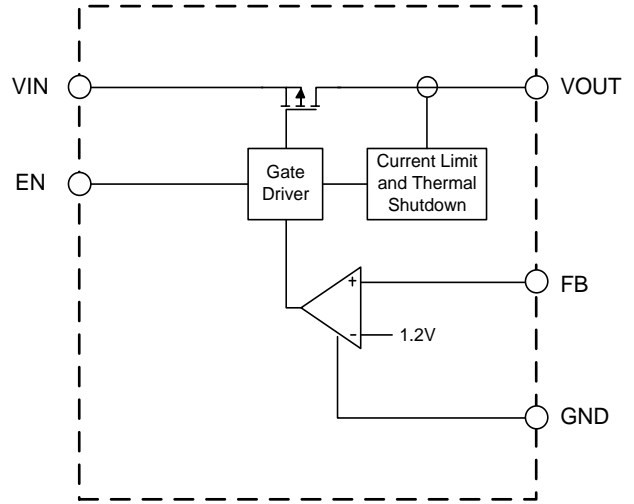

AP7583Q Adjustable Version

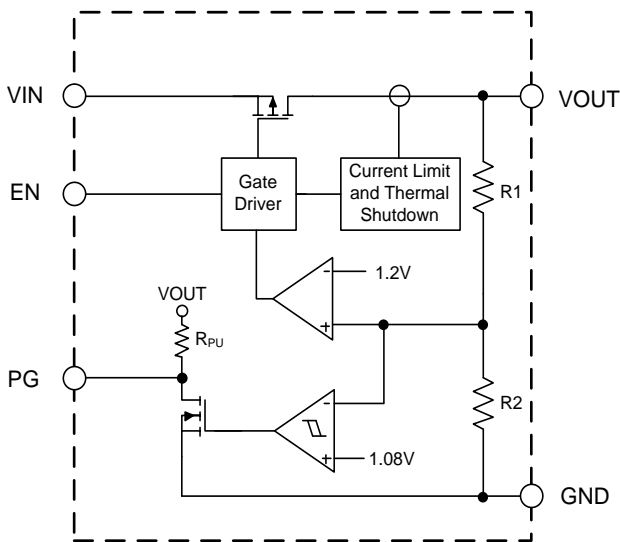

AP7583AQ Fixed Version

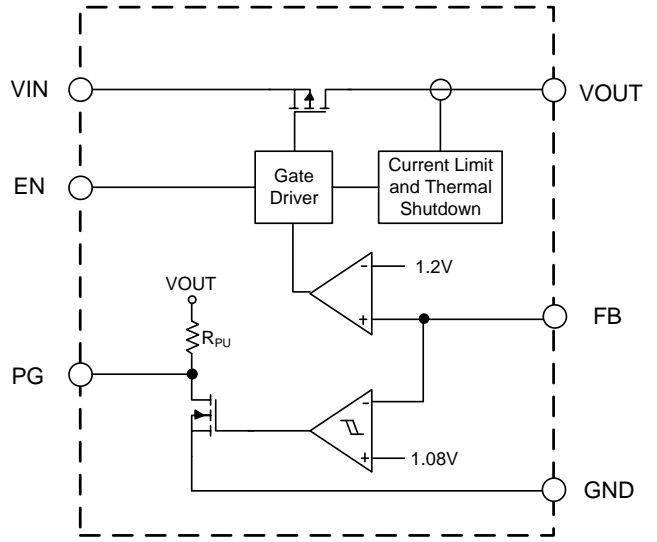

AP7583AQ Adjustable Version

Absolute Maximum Ratings (Note 4) (@T_A = +25°C, unless otherwise specified.)

Symbol	Parameter	Rating		Unit
V _{IN}	Supply Input Voltage	-0.3 to 45		V
V _{OUT}	Regulated Output Voltage	-0.3 to 7		V
I _{OUT}	Output Current	300		mA
T _{LEAD}	Lead Temperature (Soldering, 10sec)	+260		°C
T _J	Operating Junction Temperature	+150		°C
θ _{JA}	Thermal Resistance (Junction to Ambient)	MSOP-8EP	36.1	°C/W
		W-DFN2020-6 (SWP) (Type A1)	80.4	
		TO252-4 (Type C)	27.2	
θ _{JC}	Thermal Resistance (Junction to Case)	MSOP-8EP	6.532	°C/W
		W-DFN2020-6 (SWP) (Type A1)	26.4	
		TO252-4 (Type C)	7.5	
T _{STG}	Storage Temperature Range	-40 to +150		°C
CDM	ESD (Charged Device Model)	±1500		V
HBM	ESD (Human Body Model)	±2000		V

- Notes:
- a. Stresses beyond those listed under *Absolute Maximum Ratings* can cause permanent damage to the device. These are stress ratings only and functional operation of the device at these conditions is not implied. Exposure to absolute-maximum-rated conditions for extended period can affect device reliability.
 - b. Ratings apply to ambient temperature at +25°C. The JEDEC STD.51 High-K board design used to derive this data was a 3inch x 3inch multilayer board with 1oz. internal power and ground planes and 2oz. copper traces on the top and bottom of the board.

Recommended Operating Conditions

Symbol	Parameter	Min	Max	Unit
V _{IN}	Supply Input Voltage	3.0	42	V
V _{OUT}	Supply Output Voltage	1.2	5	V
T _J	Operating Junction Temperature	-40	+125	°C

Caution: V_{IN} ramp-up slew rate needs to be slower than 200µs/V for proper operations under EN stays HIGH all the time.

Electrical Characteristics (-40°C ≤ T_J ≤ +125°C, I_{OUT} = 1mA, C_{IN} = C_{OUT} = 10μF ceramic capacitor, V_{IN} = 14V)

Symbol	Parameter	Test Conditions	Min	Typ	Max	Unit
V _{OUT}	Output Voltage	Variation from Specified V _{OUT}	V _{OUT} * 98.5%	—	V _{OUT} * 101.5%	V
V _{IN}	Input Voltage	—	3.0	—	42	V
V _{FB}	Feedback Reference Voltage	—	1.183	1.207	1.231	V
I _{LIMIT}	Current Limit	V _{OUT} Short to 90% x V _{OUT}	310	510	690	mA
ΔV _{OUT} /ΔV _{IN}	Line Regulation	V _{IN} = V _{OUT} + 1V to 40V, I _{OUT} = 1mA	-10	—	10	mV
ΔV _{OUT} /V _{OUT}	Load Regulation	1mA ≤ I _{OUT} ≤ 300mA	-20	—	20	mV
V _{DROP}	Dropout Voltage (Note 5)	I _{OUT} = 300mA @ V _{OUT} = 3.3V	—	450	700	mV
		I _{OUT} = 300mA @ V _{OUT} = 5V	—	320	500	mV
I _Q	Quiescent Current	AP7583Q I _{OUT} = 0	—	2.5	4.0	μA
		AP7583AQ I _{OUT} = 0	—	3	6	μA
I _{SHUTDOWN}	Shutdown Current	EN = 0	—	0.3	0.5	μA
V _{IL}	EN Input Logic-Low Voltage	—	0	—	0.3	V
V _{IH}	EN Input Logic-High Voltage	—	1.7	—	V _{IN}	V
ΔV _{OUT} /(V _{OUT} ΔT)	Output Voltage Temperature Coefficient	I _{OUT} = 100μA, -40°C ≤ T _J ≤ +125°C	—	±100	—	ppm/°C
T _{OTSD}	Thermal Shutdown Temperature	—	—	+175	—	°C
T _{HYOTSD}	Thermal Shutdown Hysteresis	—	—	+20	—	°C
PSRR	Power-Supply Rejection Ratio	V _(Ripple) = 0.5V _{PP} , I _{OUT} = 10mA, Frequency = 100Hz, C _{OUT} = 2.2μF	—	70	—	dB
UVLO	V _{IN} Undervoltage Detection	Ramp V _{IN} up until the Output Turns on	2.1	2.4	2.7	V
		Hysteresis	—	0.2	—	V
I _{FB}	FB Leakage Current	FB = 0 (Adjustable Version)	-10	—	20	nA
AP7583AQ						
t _D	Output Voltage Turn-On Delay Time	V _{EN} High to V _{OUT} Rising 10%	—	0.8	—	ms
t _{SS}	Output Voltage Ramp Up Time	V _{OUT} Rising 10% to 90%	—	200	—	μs
t _{PG}	PG React Time	V _{OUT} 90% to PG Active	—	30	—	μs
t _{PGF}	PG Off Deglitch Time	V _{FB} Falling to PG Low	—	3	—	μs
		EN Goes Low to PG Low				
V _{PGR}	PG Rising Threshold	V _{FB} Rising	90	—	94	%
V _{PGF}	PG Falling Threshold	V _{FB} Falling	88	—	92	%
V _{PGS}	PG Sinking Voltage	Sinking Current = 5mA	—	—	0.4	V

Note: 5. Dropout voltage is the voltage difference between the input and the output at which the output voltage drops 2% below its nominal value.

Typical Characteristics ($C_{IN} = C_{OUT} = 10\mu F$)

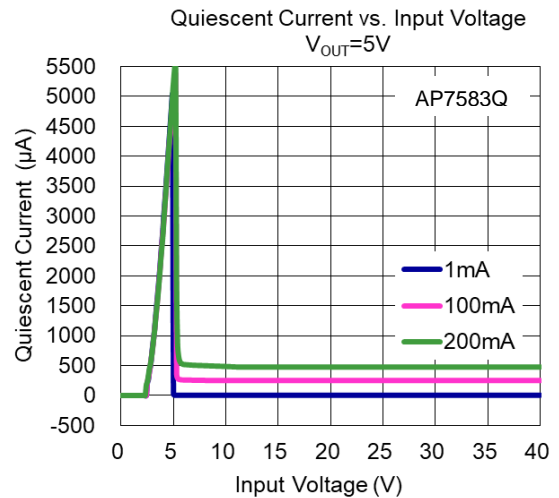
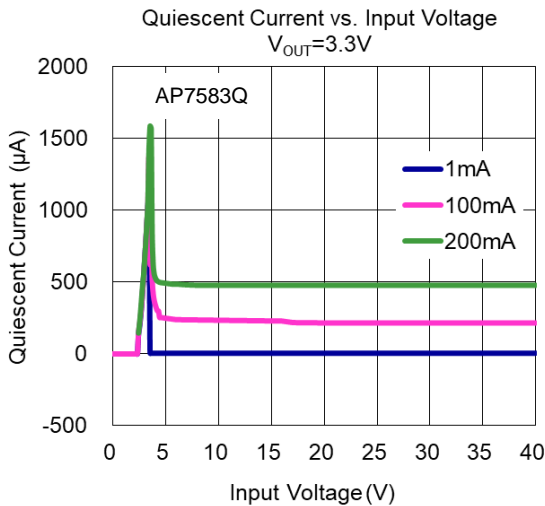
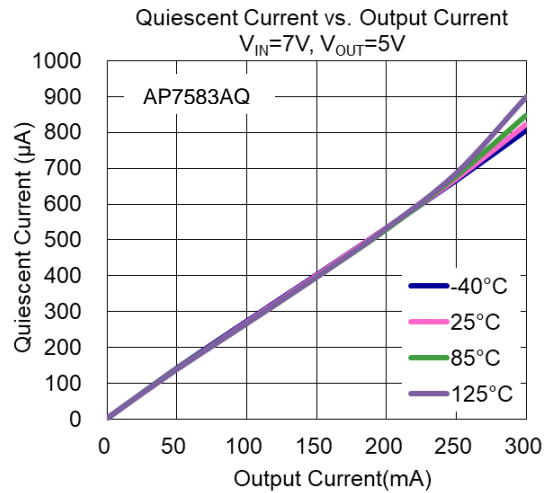
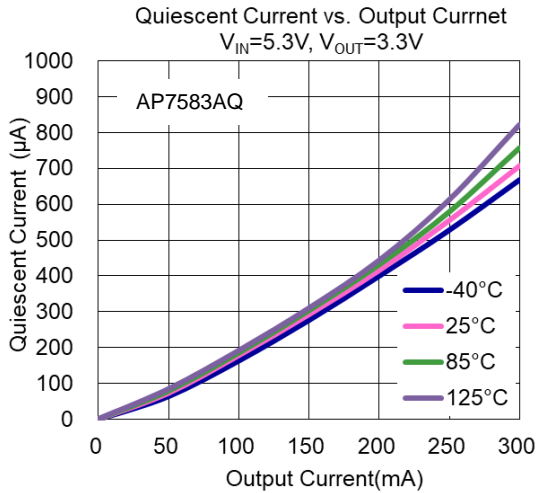
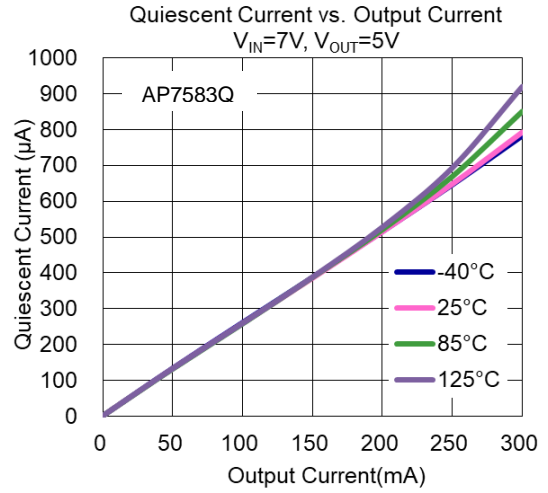
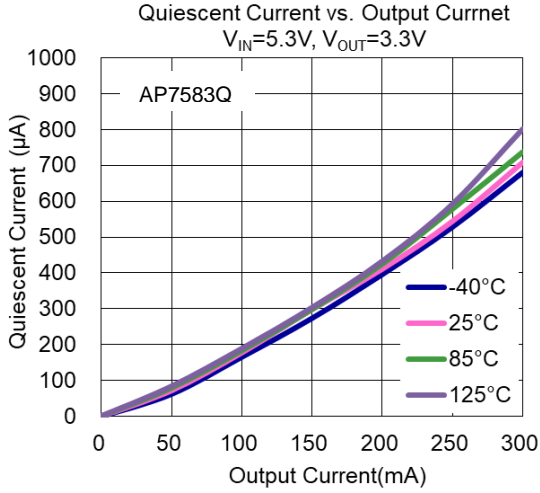

Typical Characteristics ($C_{IN} = C_{OUT} = 10\mu F$) (continued)

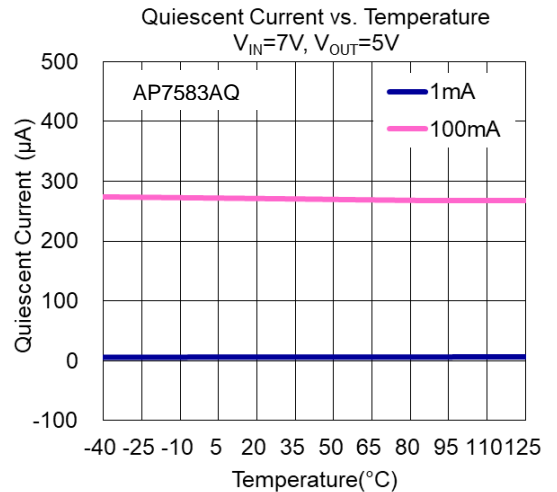
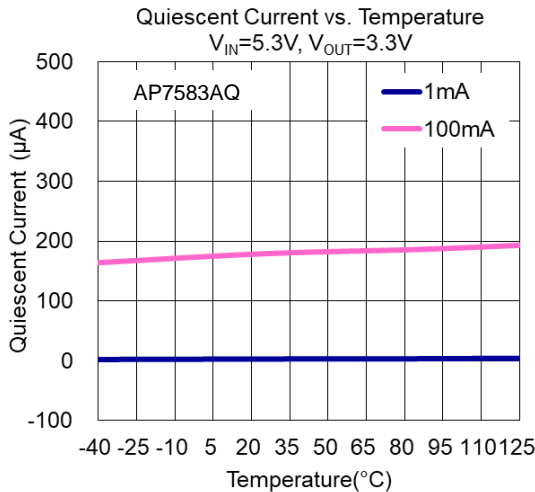
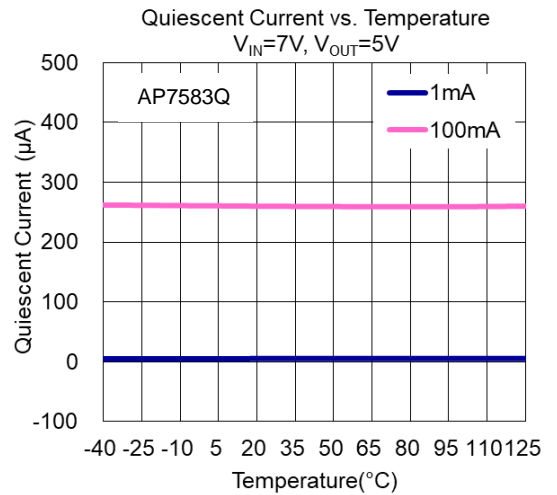
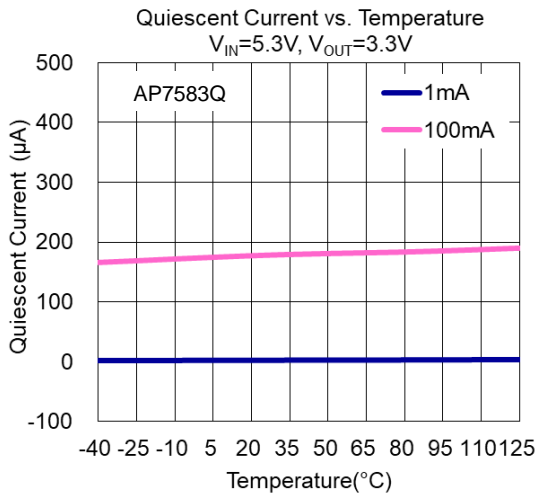
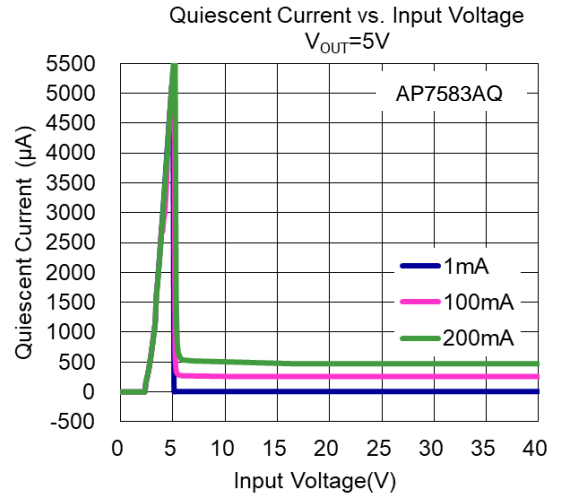
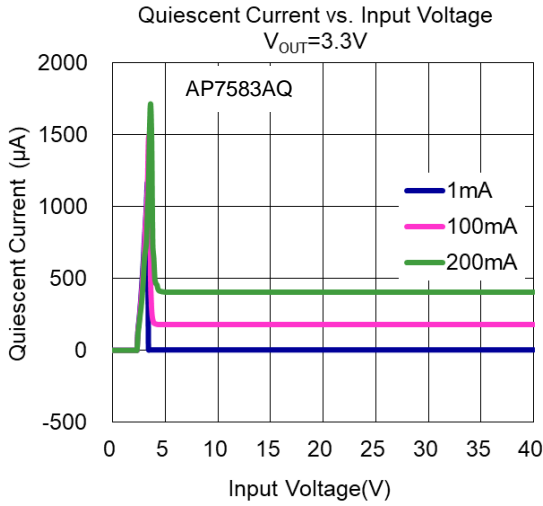

Typical Characteristics ($C_{IN} = C_{OUT} = 10\mu F$) (continued)

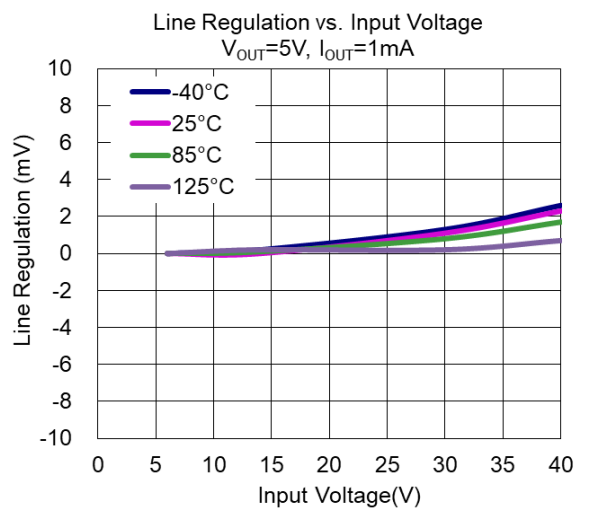
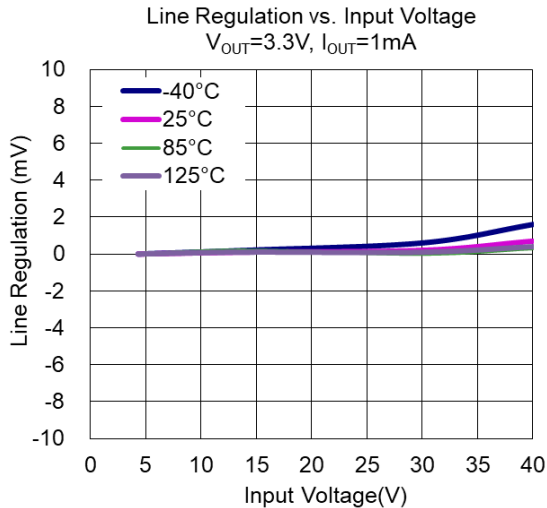
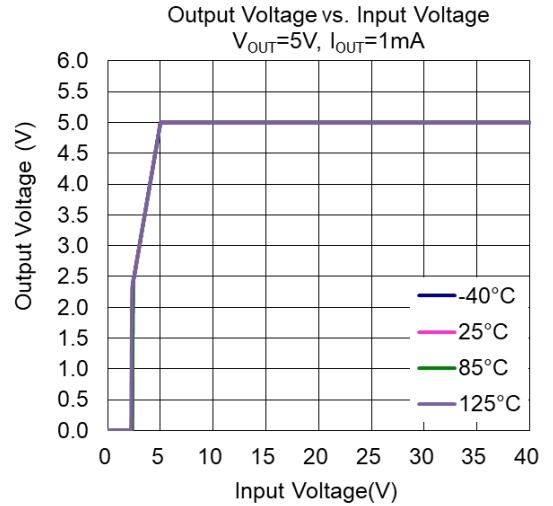
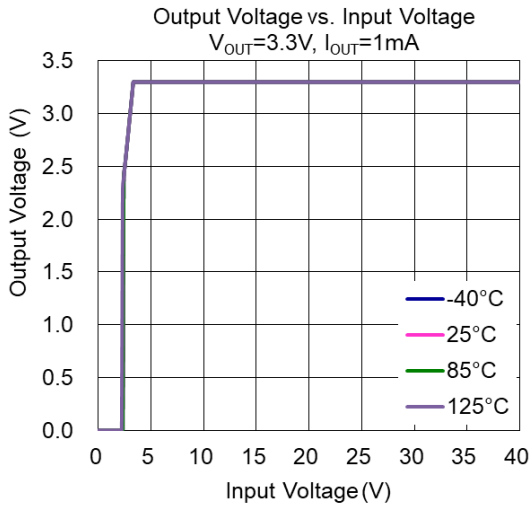
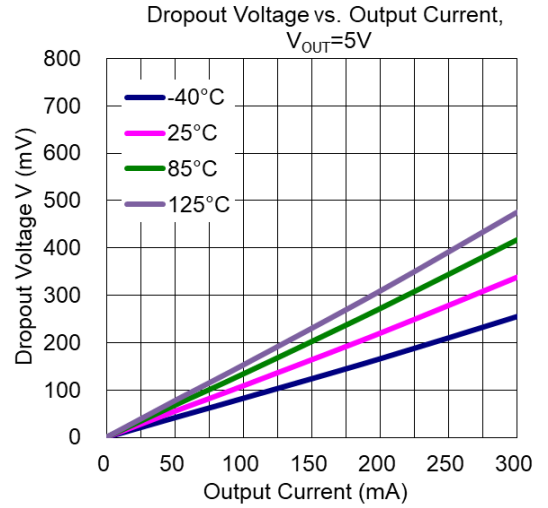
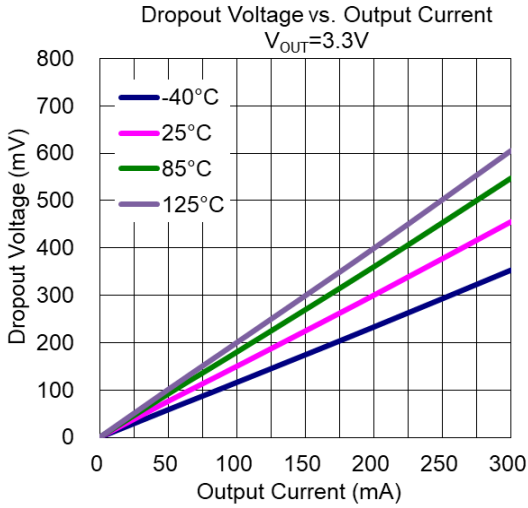

Typical Characteristics ($C_{IN} = C_{OUT} = 10\mu F$) (continued)

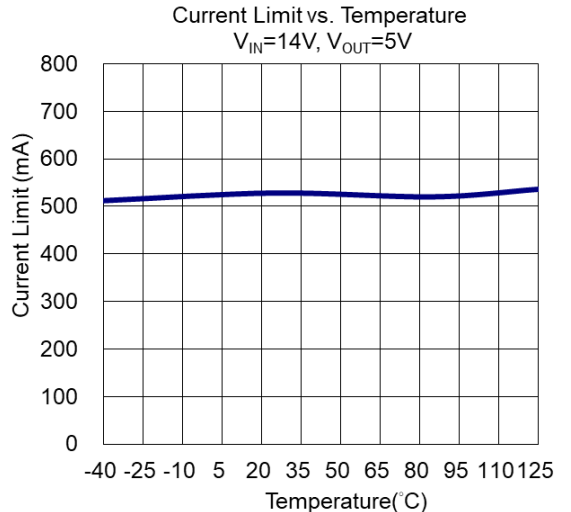
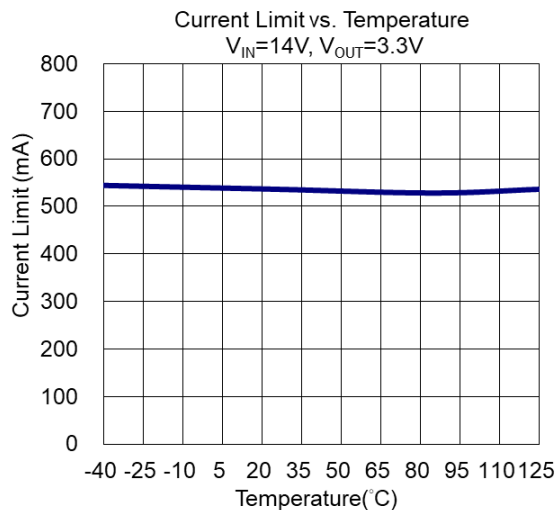
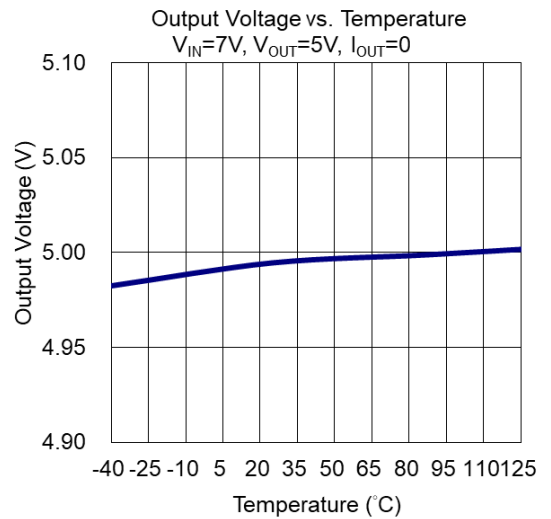
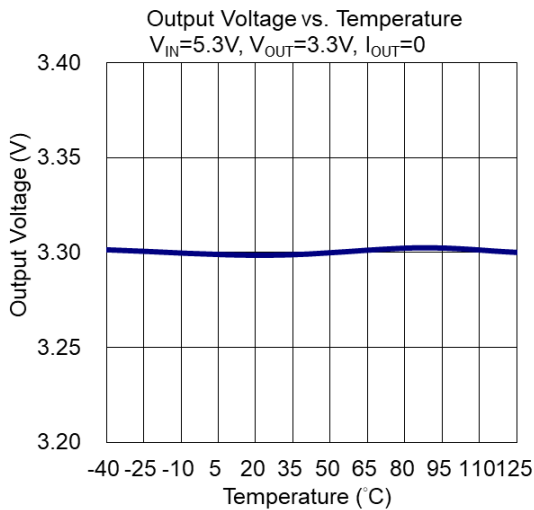
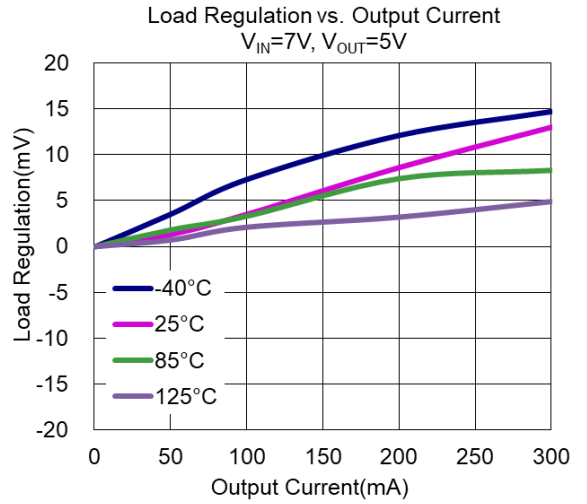
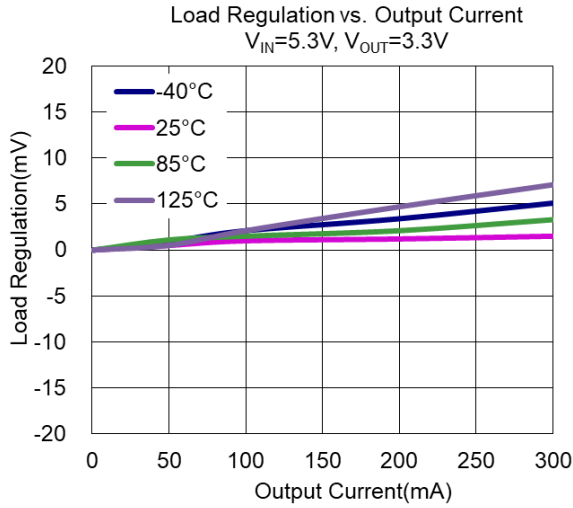

Typical Characteristics ($C_{IN} = C_{OUT} = 10\mu F$) (continued)

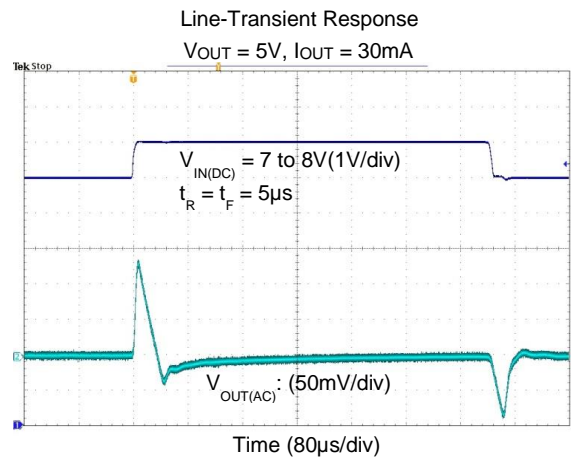
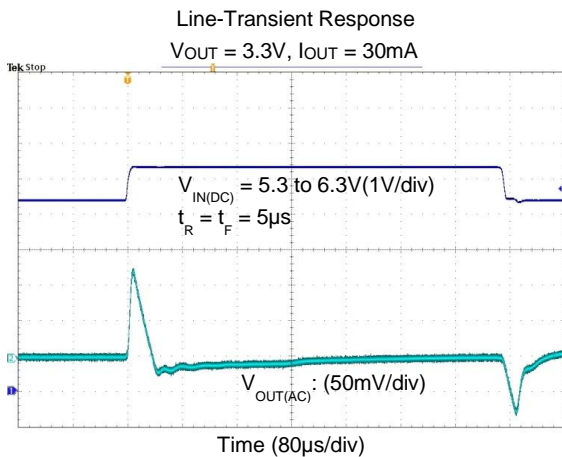
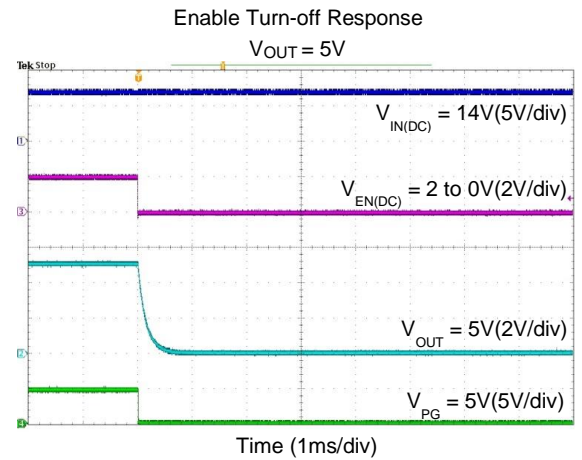
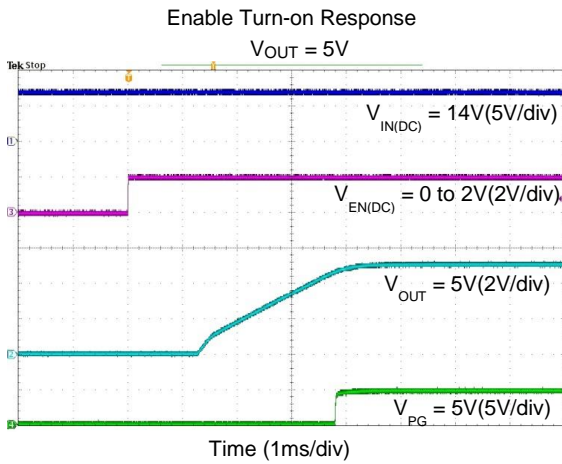
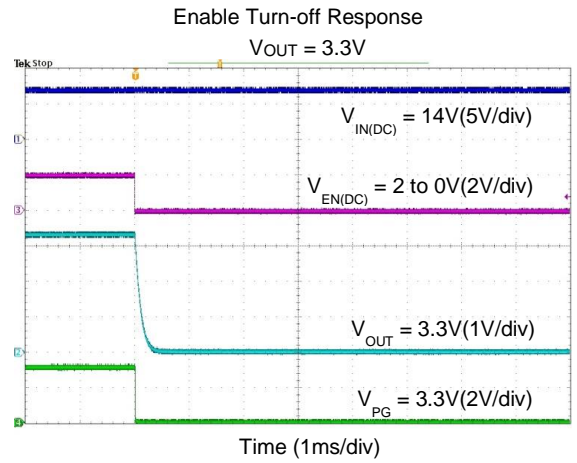
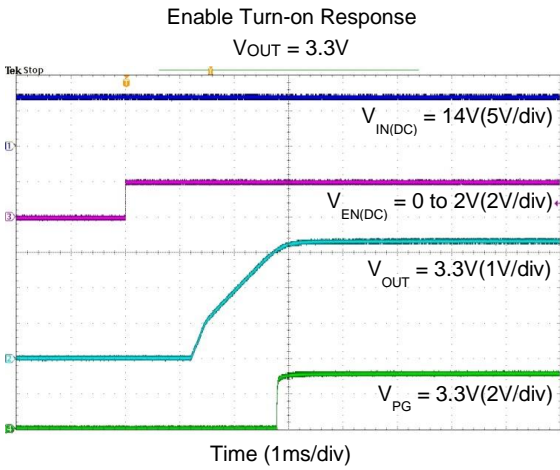

Typical Characteristics ($C_{IN} = C_{OUT} = 10\mu F$) (continued)

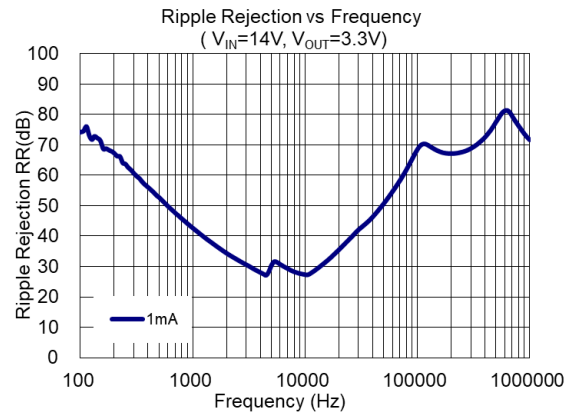
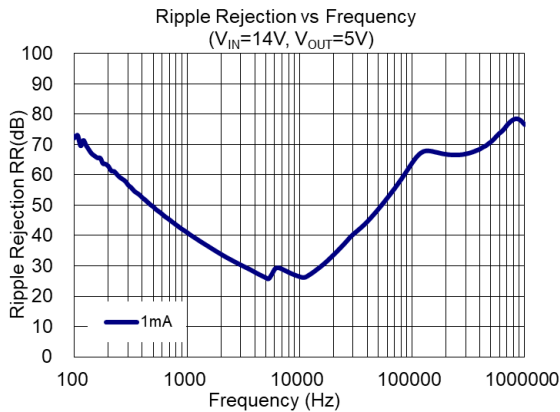
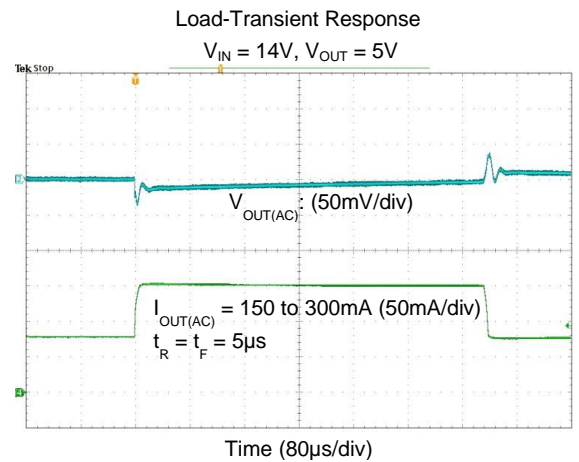
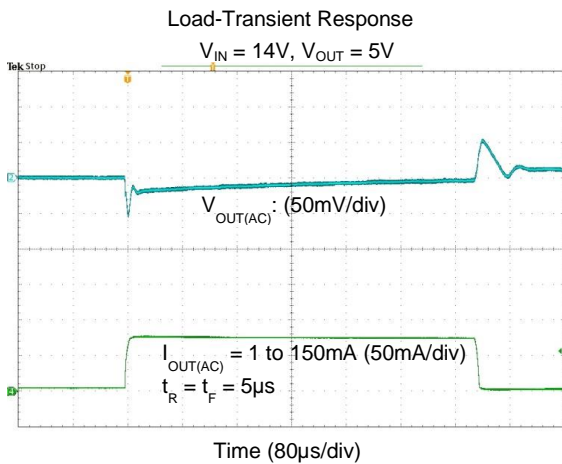
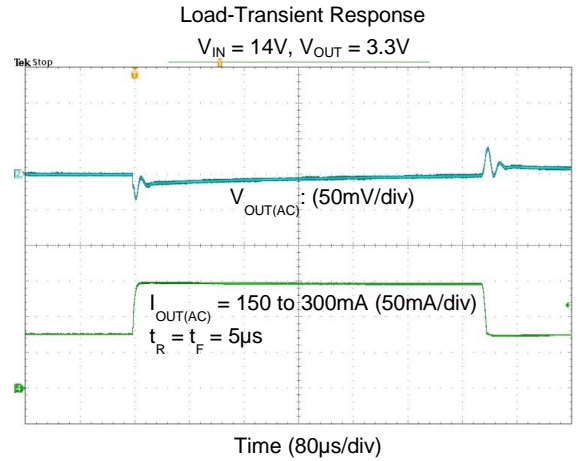
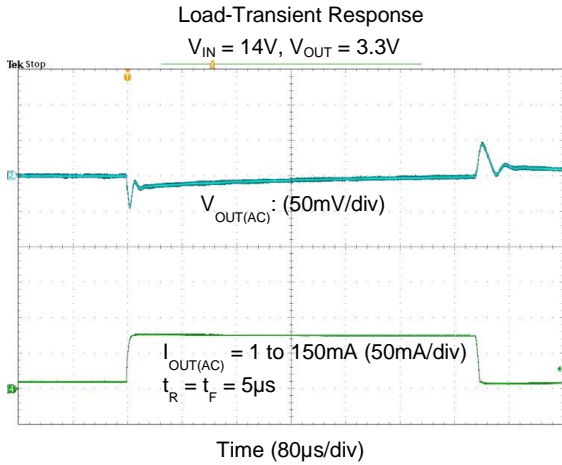

Application Information

Input Capacitor

A 10µF ceramic capacitor is recommended between IN and GND pins to decouple input power-supply glitch and noise. The amount of the capacitance may be increased without limit. This input capacitor must be located as close as possible to the device to assure input stability and reduce noise. For PCB layout, a wide copper trace is required for both IN and GND pins. A lower ESR capacitor type allows the use of less capacitance, while higher ESR type requires more capacitance.

Output Capacitor

Ceramic type output capacitor is recommended for this series; however, the other output capacitors with low ESR also can be used. One 10µF output capacitor is suggested, the AP7583Q/AQ series LDO would have stable output capacitance range from 4.7µF to 100µF. The relations between I_{OUT} (Output Current) and ESR of an output capacitor are shown below. The stable region for the safety operating temperature (-40°C to +125°C) is marked as the gray area in the graph.

Measurement conditions: Frequency Band: 10Hz to 2MHz, Temperature: -40°C to +125°C.

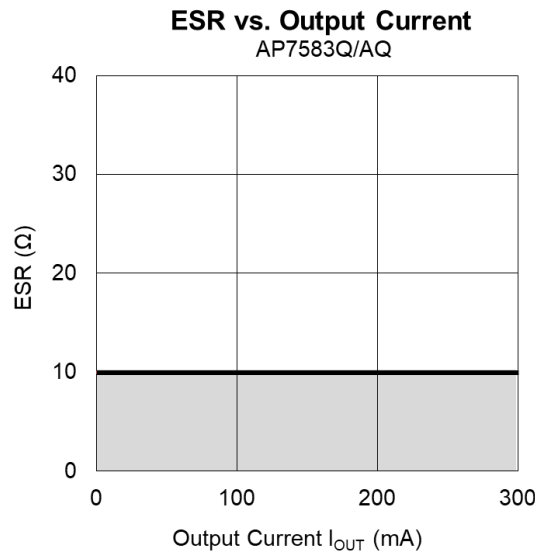

Adjustable Operation

The AP7583Q/AQ provide output voltage from 1.2V to 5.0V through external resistor divider as shown below:

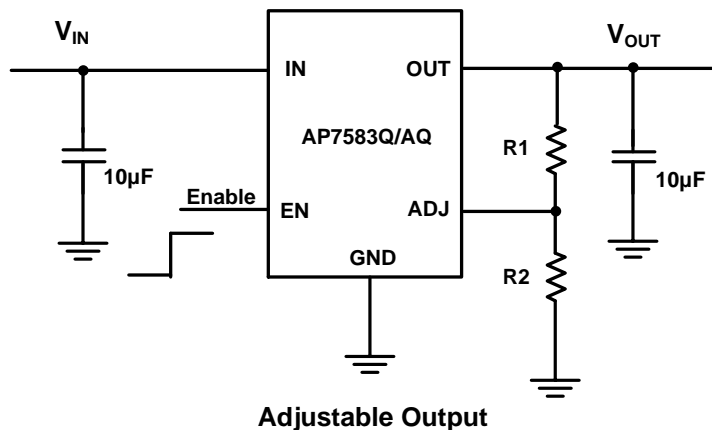

Application Information (continued)

The output voltage is calculated by:

$$V_{OUT} = V_{REF} \left(1 + \frac{R_1}{R_2} \right)$$

Where $V_{REF} = 1.2V$ (the internal reference voltage).

Rearranging the equation will give the following that is used for adjusting the output to a particular voltage:

$$R_1 = R_2 \left(\frac{V_{OUT}}{V_{REF}} - 1 \right)$$

To maintain the stability of the internal reference voltage, R_2 needs to be kept smaller than $80k\Omega$.

No Load Stability

Other than external resistor divider, no minimum load is required to keep the device stable. The device will remain stable and regulated in no load condition.

ON/OFF Input Operation

The AP7583Q/AQ are turned on by setting the EN pin high, and is turned off by pulling it low. If this feature is not used, the EN pin should be tied to IN pin to keep the regulator output on at all time. To ensure proper operation, the signal source used to drive the EN pin must be able to swing above and below the specified turn-on/off voltage thresholds listed in the *Electrical Characteristics* section under V_{IL} and V_{IH} .

Current-Limit Protection

When output current at OUT pin is higher than current-limit threshold, the current-limit protection will be triggered and clamp the output current to prevent overcurrent and to protect the regulator from damage due to overheating.

Power-Good

The power-good (PG) pin is an open-drain output with one internal resistor. When the $V_{OUT} \geq V_{PGR}$, the PG output is high-impedance; if the V_{OUT} drops to below V_{PGF} , or the device is disabled, the PG pin is pulled to low by an internal MOSFET.

Thermal Shutdown Protection

Thermal protection disables the output when the junction temperature rises to approximately $+175^\circ\text{C}$, allowing the device to cool down. When the junction temperature reduces to approximately $+155^\circ\text{C}$, the output circuitry is enabled again. Depending on power dissipation, thermal resistance, and ambient temperature, the thermal protection circuit may cycle on and off. This cycling limits the heat dissipation of the regulator, protecting it from damage due to overheating.

Power Dissipation

The device power dissipation and proper sizing of the thermal plane that is connected to the thermal pad is critical to avoid thermal shutdown and ensure reliable operation. Power dissipation of the device depends on input voltage and load conditions and can be calculated by:

$$P_D = (V_{IN} - V_{OUT}) \times I_{OUT}$$

The maximum power dissipation, handled by the device, depends on the maximum junction to ambient thermal resistance, maximum ambient temperature, and maximum device junction temperature, which can be calculated by the equation in the following:

$$P_D(\text{max}@T_A) = \frac{(+150^\circ\text{C} - T_A)}{R_{\theta JA}}$$

Ordering Information (Note 6)

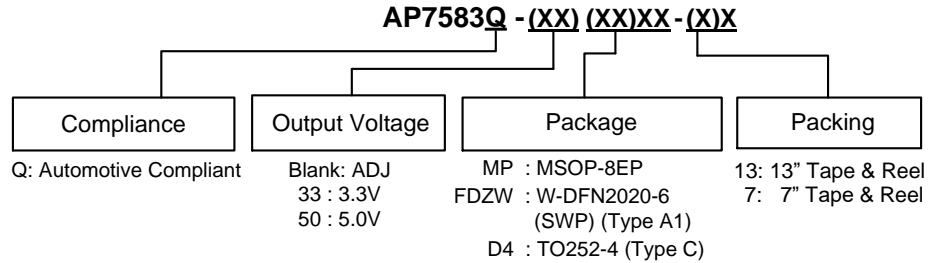

Orderable Part Number	Package Code	Package	Packing	
			Qty.	Carrier
AP7583Q-MP-13	MP	MSOP-8EP	2,500	13" Tape & Reel
AP7583Q-XXMP-13	MP	MSOP-8EP	2,500	13" Tape & Reel
AP7583Q-FDZW-7	FDZW	W-DFN2020-6 (SWP) (Type A1)	3,000	7" Tape & Reel
AP7583Q-XXFDZW-7	FDZW	W-DFN2020-6 (SWP) (Type A1)	3,000	7" Tape & Reel
AP7583Q-XXD4-13	D4	TO252-4 (Type C)	2,500	13" Tape & Reel

Note: 6. For packaging details, go to our website at <https://www.diodes.com/design/support/packaging/diodes-packaging/>.

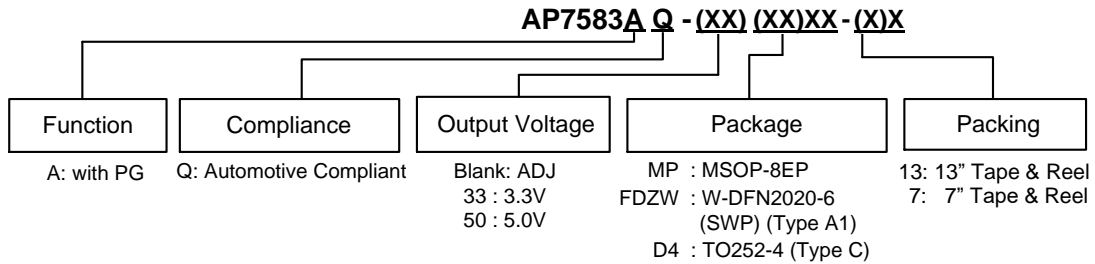

Orderable Part Number	Package Code	Package	Packing	
			Qty.	Carrier
AP7583AQ-MP-13	MP	MSOP-8EP	2,500	13" Tape & Reel
AP7583AQ-XXMP-13	MP	MSOP-8EP	2,500	13" Tape & Reel
AP7583AQ-FDZW-7	FDZW	W-DFN2020-6 (SWP) (Type A1)	3,000	7" Tape & Reel
AP7583AQ-XXFDZW-7	FDZW	W-DFN2020-6 (SWP) (Type A1)	3,000	7" Tape & Reel
AP7583AQ-XXD4-13	D4	TO252-4 (Type C)	2,500	13" Tape & Reel

Note: 6. For packaging details, go to our website at <https://www.diodes.com/design/support/packaging/diodes-packaging/>.

Marking Information (AP7583Q)

(1) MSOP-8EP

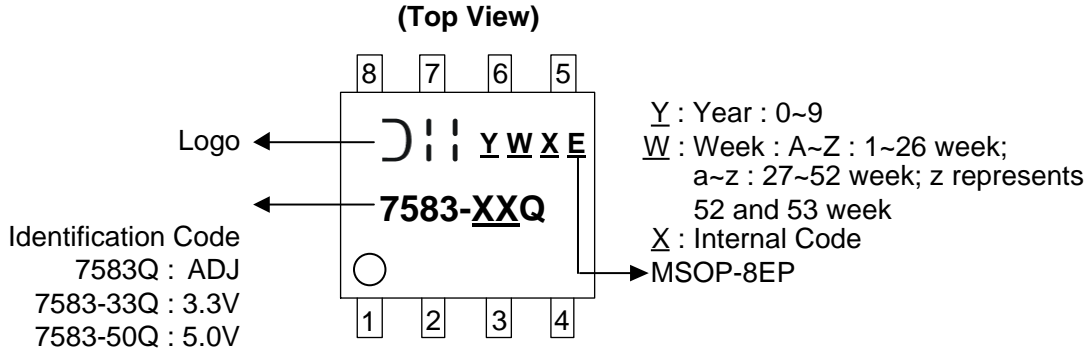

Orderable Part Number	Package	Identification Code
AP7583Q-MP-13	MSOP-8EP	7583Q
AP7583Q-33MP-13	MSOP-8EP	7583-33Q
AP7583Q-50MP-13	MSOP-8EP	7583-50Q

(2) W-DFN2020-6 (SWP) (Type A1)

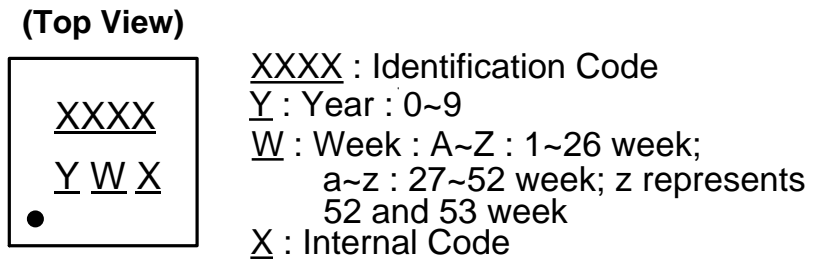

Orderable Part Number	Package	Identification Code
AP7583Q-FDZW-7	W-DFN2020-6 (SWP) (Type A1)	F7AQ
AP7583Q-33FDZW-7	W-DFN2020-6 (SWP) (Type A1)	F7DQ
AP7583Q-50FDZW-7	W-DFN2020-6 (SWP) (Type A1)	F7EQ

Marking Information (AP7583Q) (continued)

(3) TO252-4 (Type C)

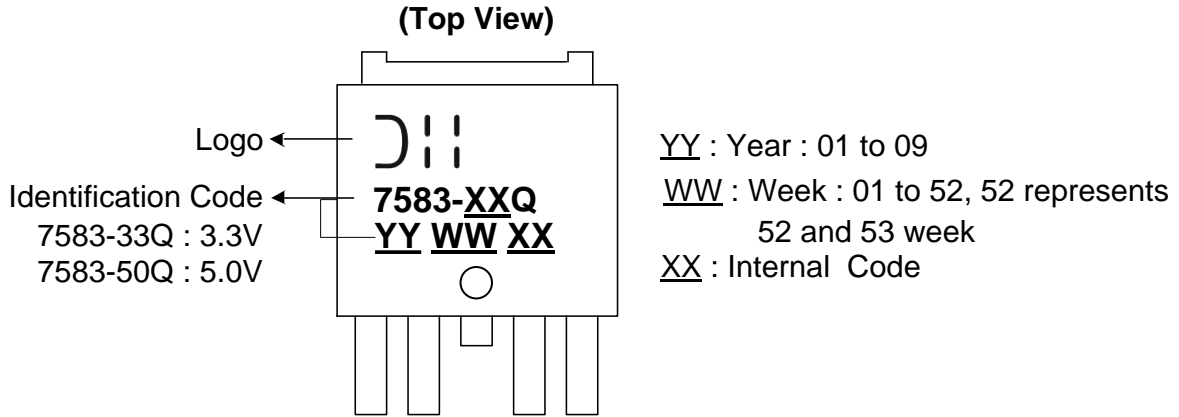

Orderable Part Number	Package	Identification Code
AP7583Q-33D4-13	TO252-4 (Type C)	7583-33Q
AP7583Q-50D4-13	TO252-4 (Type C)	7583-50Q

Marking Information (AP7583AQ)

(1) MSOP-8EP

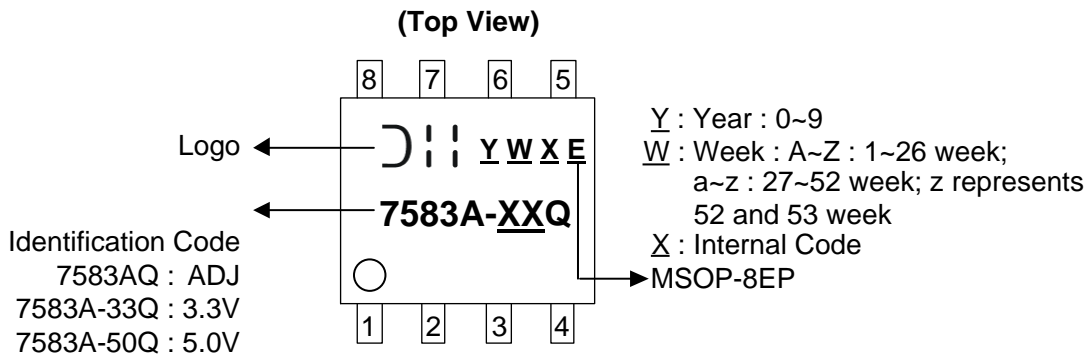

Orderable Part Number	Package	Identification Code
AP7583AQ-MP-13	MSOP-8EP	7583AQ
AP7583AQ-33MP-13	MSOP-8EP	7583A-33Q
AP7583AQ-50MP-13	MSOP-8EP	7583A-50Q

Marking Information (AP7583AQ) (continued)

(2) W-DFN2020-6 (SWP) (Type A1)

(Top View)

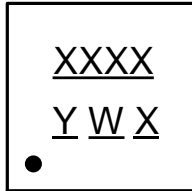

XXXX : Identification Code
Y : Year : 0~9
W : Week : A~Z : 1~26 week;
 a~z : 27~52 week; z represents
 52 and 53 week
X : Internal Code

Orderable Part Number	Package	Identification Code
AP7583AQ-FDZW-7	W-DFN2020-6 (SWP) (Type A1)	F8AQ
AP7583AQ-33FDZW -7	W-DFN2020-6 (SWP) (Type A1)	F8DQ
AP7583AQ-50FDZW -7	W-DFN2020-6 (SWP) (Type A1)	F8EQ

(3) TO252-4 (Type C)

(Top View)

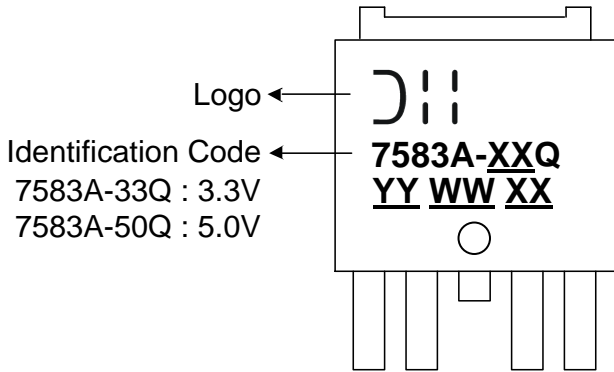

YY : Year : 01 to 09
WW : Week : 01 to 52, 52 represents
 52 and 53 week
XX : Internal Code

Logo ←
 Identification Code ←
 7583A-33Q : 3.3V
 7583A-50Q : 5.0V

Orderable Part Number	Package	Identification Code
AP7583AQ-33D4-13	TO252-4 (Type C)	7583A-33Q
AP7583AQ-50D4-13	TO252-4 (Type C)	7583A-50Q

Package Outline Dimensions

Please see <http://www.diodes.com/package-outlines.html> for the latest version.

(1) MSOP-8EP

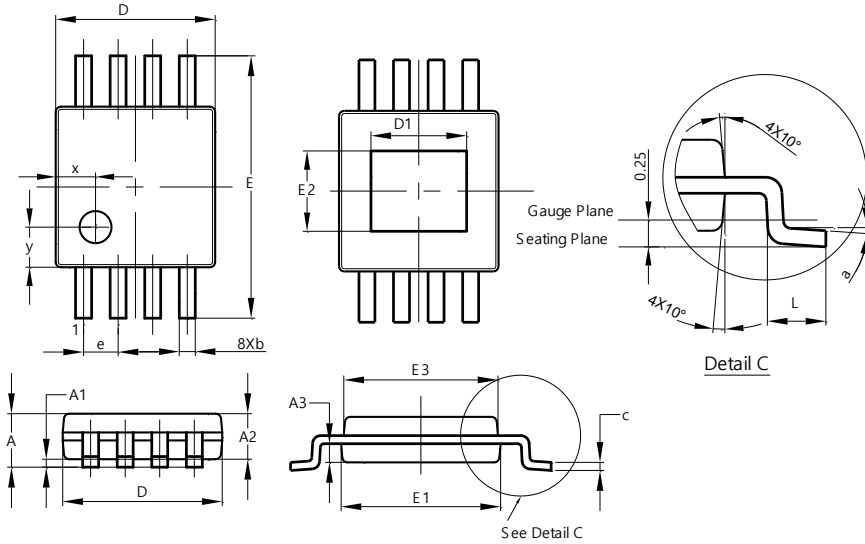

MSOP-8EP			
Dim	Min	Max	Typ
A	-	1.10	-
A1	0.05	0.15	0.10
A2	0.75	0.95	0.86
A3	0.29	0.49	0.39
b	0.22	0.38	0.30
c	0.08	0.23	0.15
D	2.90	3.10	3.00
D1	1.60	2.00	1.80
E	4.70	5.10	4.90
E1	2.90	3.10	3.00
E2	1.30	1.70	1.50
E3	2.85	3.05	2.95
e	-	-	0.65
L	0.40	0.80	0.60
a	0°	8°	4°
x	-	-	0.750
y	-	-	0.750
All Dimensions in mm			

(2) W-DFN2020-6 (SWP) (Type A1)

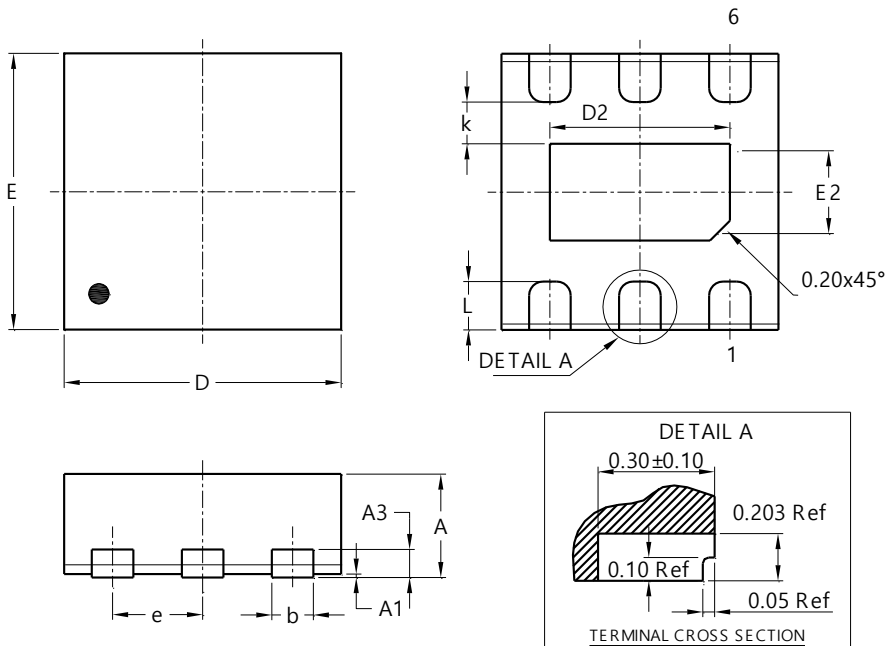

W-DFN2020-6 (SWP) (Type A1)			
Dim	Min	Max	Typ
A	0.70	0.80	0.75
A1	0.00	0.05	0.02
A3	0.203 REF		
b	0.25	0.35	0.30
D	2.00 BSC		
D2	1.35	1.45	1.40
E	2.00 BSC		
E2	0.55	0.65	0.60
e	0.65 BSC		
k	0.20	—	—
L	0.20	0.40	0.30
All Dimensions in mm			

Package Outline Dimensions (continued)

Please see <http://www.diodes.com/package-outlines.html> for the latest version.

(3) TO252-4 (Type C)

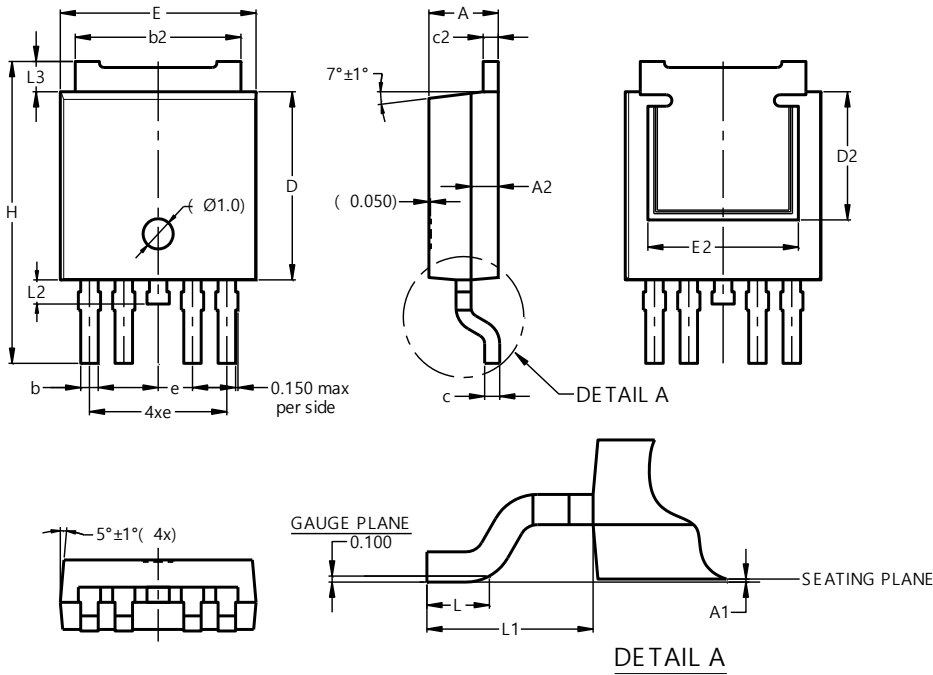

TO252-4 (Type C)			
Dim	Min	Max	Typ
A	2.20	2.35	--
A1	0.00	0.15	--
A2	0.80	1.00	--
b	0.50	0.70	0.60
b2	5.30	5.70	--
c	0.46	0.58	--
c2	0.46	0.58	--
D	6.02	6.22	--
D2	4.24REF		
e	1.14BSC		
E	6.45	6.65	--
E2	5.00REF		
H	9.48	10.48	9.98
L	0.60	--	--
L1	2.76REF		
L2	0.65	0.95	0.80
L3	0.90	1.10	1.00
All Dimensions in mm			

Suggested Pad Layout

Please see <http://www.diodes.com/package-outlines.html> for the latest version.

(1) MSOP-8EP

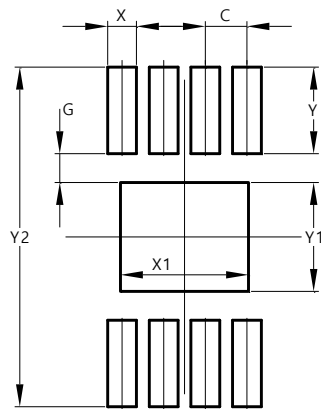

Dimensions	Value (in mm)
C	0.650
G	0.450
X	0.450
X1	2.000
Y	1.350
Y1	1.700
Y2	5.300

Suggested Pad Layout (continued)

Please see <http://www.diodes.com/package-outlines.html> for the latest version.

(2) W-DFN2020-6 (SWP) (Type A1)

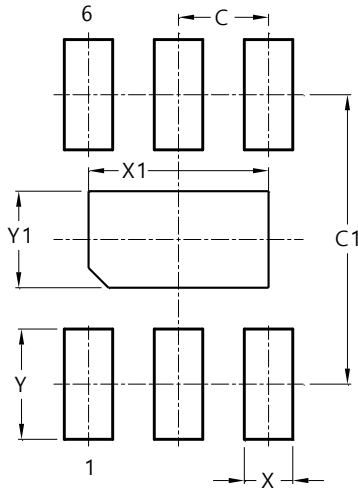

Dimensions	Value (in mm)
C	0.650
C1	2.100
X	0.350
X1	1.400
Y	0.800
Y1	0.600

(3) TO252-4 (Type C)

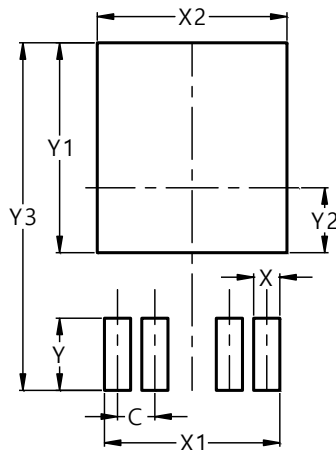

Dimensions	Value (in mm)
C	1.140
X	0.800
X1	5.360
X2	5.800
Y	2.200
Y1	6.400
Y2	1.980
Y3	10.600

Mechanical Data

- Moisture Sensitivity:
 - MSOP-8EP: Level 1 Per J-STD-020
 - W-DFN2020-6 (SWP) (Type A1): Level 1 Per J-STD-020
 - TO252-4 (Type C): Level 3 Per J-STD-020
- Terminals: Finish - Matte Tin Plated Leads, Solderable per MIL-STD-202, Method 208 e3
- Weight:
 - MSOP-8EP: 0.024 grams (Approximate)
 - W-DFN2020-6 (SWP) (Type A1): 0.01 grams (Approximate)
 - TO252-4 (Type C): 0.343 grams (Approximate)

IMPORTANT NOTICE

1. DIODES INCORPORATED (Diodes) AND ITS SUBSIDIARIES MAKE NO WARRANTY OF ANY KIND, EXPRESS OR IMPLIED, WITH REGARDS TO ANY INFORMATION CONTAINED IN THIS DOCUMENT, INCLUDING, BUT NOT LIMITED TO, THE IMPLIED WARRANTIES OF MERCHANTABILITY, FITNESS FOR A PARTICULAR PURPOSE OR NON-INFRINGEMENT OF THIRD PARTY INTELLECTUAL PROPERTY RIGHTS (AND THEIR EQUIVALENTS UNDER THE LAWS OF ANY JURISDICTION).
2. The Information contained herein is for informational purpose only and is provided only to illustrate the operation of Diodes' products described herein and application examples. Diodes does not assume any liability arising out of the application or use of this document or any product described herein. This document is intended for skilled and technically trained engineering customers and users who design with Diodes' products. Diodes' products may be used to facilitate safety-related applications; however, in all instances customers and users are responsible for (a) selecting the appropriate Diodes products for their applications, (b) evaluating the suitability of Diodes' products for their intended applications, (c) ensuring their applications, which incorporate Diodes' products, comply the applicable legal and regulatory requirements as well as safety and functional-safety related standards, and (d) ensuring they design with appropriate safeguards (including testing, validation, quality control techniques, redundancy, malfunction prevention, and appropriate treatment for aging degradation) to minimize the risks associated with their applications.
3. Diodes assumes no liability for any application-related information, support, assistance or feedback that may be provided by Diodes from time to time. Any customer or user of this document or products described herein will assume all risks and liabilities associated with such use, and will hold Diodes and all companies whose products are represented herein or on Diodes' websites, harmless against all damages and liabilities.
4. Products described herein may be covered by one or more United States, international or foreign patents and pending patent applications. Product names and markings noted herein may also be covered by one or more United States, international or foreign trademarks and trademark applications. Diodes does not convey any license under any of its intellectual property rights or the rights of any third parties (including third parties whose products and services may be described in this document or on Diodes' website) under this document.
5. Diodes' products are provided subject to Diodes' Standard Terms and Conditions of Sale (<https://www.diodes.com/about/company/terms-and-conditions/terms-and-conditions-of-sales/>) or other applicable terms. This document does not alter or expand the applicable warranties provided by Diodes. Diodes does not warrant or accept any liability whatsoever in respect of any products purchased through unauthorized sales channel.
6. Diodes' products and technology may not be used for or incorporated into any products or systems whose manufacture, use or sale is prohibited under any applicable laws and regulations. Should customers or users use Diodes' products in contravention of any applicable laws or regulations, or for any unintended or unauthorized application, customers and users will (a) be solely responsible for any damages, losses or penalties arising in connection therewith or as a result thereof, and (b) indemnify and hold Diodes and its representatives and agents harmless against any and all claims, damages, expenses, and attorney fees arising out of, directly or indirectly, any claim relating to any noncompliance with the applicable laws and regulations, as well as any unintended or unauthorized application.
7. While efforts have been made to ensure the information contained in this document is accurate, complete and current, it may contain technical inaccuracies, omissions and typographical errors. Diodes does not warrant that information contained in this document is error-free and Diodes is under no obligation to update or otherwise correct this information. Notwithstanding the foregoing, Diodes reserves the right to make modifications, enhancements, improvements, corrections or other changes without further notice to this document and any product described herein. This document is written in English but may be translated into multiple languages for reference. Only the English version of this document is the final and determinative format released by Diodes.
8. Any unauthorized copying, modification, distribution, transmission, display or other use of this document (or any portion hereof) is prohibited. Diodes assumes no responsibility for any losses incurred by the customers or users or any third parties arising from any such unauthorized use.
9. This Notice may be periodically updated with the most recent version available at <https://www.diodes.com/about/company/terms-and-conditions/important-notice>

The Diodes logo is a registered trademark of Diodes Incorporated in the United States and other countries.
All other trademarks are the property of their respective owners.
© 2025 Diodes Incorporated. All Rights Reserved.

www.diodes.com

Looking for pricing, stock, or lifecycle information?

Click below to explore more details on WIN SOURCE:

 [View CL0306KRX7R6BB104 on WIN SOURCE](#)

 [Yageo Information](#)

Optimize Your Supply Chain with WIN SOURCE Solutions

-  Global Sourcing Solution
-  Obsolete Management
-  Cost Control Management
-  Shortage Management
-  Alternative Solution
-  Excess Inventory Management