



**THE DATASHEET OF
APTF1616LSEKJ3ZGKQBC**



10-BIT 1.25-MSPS MICRO-POWER MINIATURE SAR ANALOG-TO-DIGITAL CONVERTER

Check for Samples: [ADS7887M](#)

FEATURES

- 1.25-MHz Sample Rate Serial Device
- 10-Bit Resolution
- Zero Latency
- 25-MHz Serial Interface
- Supply Range: 2.35 V to 5.25 V
- Typical Power Dissipation at 1.25 MSPS:
 - 3.8 mW at 3-V V_{DD}
 - 8 mW at 5-V V_{DD}
- ± 0.35 LSB INL, DNL
- 61-dB SINAD, -84 -dB THD
- Unipolar Input Range: 0 V to V_{DD}
- Power Down Current: 10 μ A Max
- Wide Input Bandwidth: 15 MHz at 3 dB
- 6-Pin SOT23 Package

APPLICATIONS

- Base Band Converters in Radio Communication
- Motor Current/Bus Voltage Sensors in Digital Drives
- Optical Networking (DWDM, MEMS Based Switching)
- Optical Sensors
- Battery Powered Systems
- Medical Instrumentations
- High-Speed Data Acquisition Systems
- High-Speed Closed-Loop Systems

DESCRIPTION

The ADS7887 is a 10-bit 1.25-MSPS analog-to-digital converter (ADC). The device includes a capacitor-based SAR A/D converter with inherent sample and hold. The serial interface is controlled by the \overline{CS} and SCLK signals for glueless connections with microprocessors and DSPs. The input signal is sampled with the falling edge of \overline{CS} , and SCLK is used for conversion and serial data output.

The device operates from a wide supply range from 2.35 V to 5.25 V. The low power consumption of the device makes it suitable for battery-powered applications. The device also includes a power-saving powerdown feature for when the device is operated at lower conversion speeds.

The high level of the digital input to the device is not limited to device V_{DD} . This means the digital input can go as high as 5.25 V when device supply is 2.35 V. This feature is useful when digital signals are coming from other circuits with different supply levels. Also, this relaxes restriction on power-up sequencing.

The ADS7887 is available in a 6-pin SOT23 package and is specified for operation from -55°C to 125°C .



Please be aware that an important notice concerning availability, standard warranty, and use in critical applications of Texas Instruments semiconductor products and disclaimers thereto appears at the end of this data sheet.



This integrated circuit can be damaged by ESD. Texas Instruments recommends that all integrated circuits be handled with appropriate precautions. Failure to observe proper handling and installation procedures can cause damage.

ESD damage can range from subtle performance degradation to complete device failure. Precision integrated circuits may be more susceptible to damage because very small parametric changes could cause the device not to meet its published specifications.

ORDERING INFORMATION⁽¹⁾

T _A	PACKAGE ⁽²⁾		ORDERABLE PART NUMBER	TOP-SIDE MARKING
-55°C to 125°C	SOT-23 – DBV	Reel of 250	ADS7887MDBVT	BCNM

- (1) For the most current package and ordering information, see the Package Option Addendum at the end of this document, or see the TI web site at www.ti.com.
- (2) Package drawings, thermal data, and symbolization are available at www.ti.com/packaging.

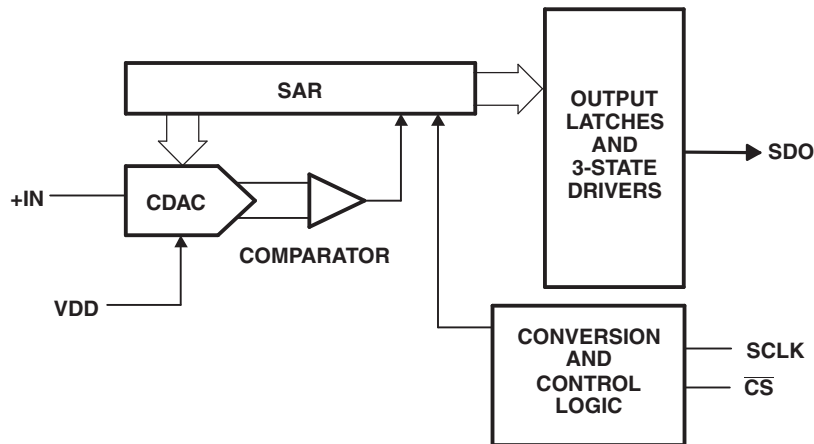

ABSOLUTE MAXIMUM RATINGS⁽¹⁾

+IN to AGND	-0.3 V to +V _{DD} +0.3 V	
+V _{DD} to AGND	-0.3 V to 7.0 V	
Digital input voltage to GND	-0.3V to (7.0 V)	
Digital output to GND	-0.3 V to (+V _{DD} + 0.3 V)	
Operating temperature range	-55°C to 125°C	
Storage temperature range	-65°C to 150°C	
Junction temperature (T _J Max)	150°C	
Power dissipation	(T _J Max – T _A)/θ _{JA}	
θ _{JA} Thermal impedance ⁽²⁾	295.2°C/W	
Lead temperature, soldering	Vapor phase (60 sec)	215°C
	Infrared (15 sec)	220°C

- (1) Stresses above those listed under *absolute maximum ratings* may cause permanent damage to the device. Exposure to absolute maximum conditions for extended periods may affect device reliability.
- (2) The package thermal impedance is calculated in accordance with JESD 51-7, except for through-hole packages, which use a trace length of zero.

ELECTRICAL SPECIFICATIONS

 $+V_{DD} = 2.35 \text{ V to } 5.25 \text{ V}$, $T_A = -55^\circ\text{C to } 125^\circ\text{C}$, $f_{\text{sample}} = 1.25 \text{ MHz}$

PARAMETER	TEST CONDITIONS	MIN	TYP	MAX	UNIT
ANALOG INPUT					
Full-scale input voltage span ⁽¹⁾		0		V_{DD}	V
Absolute input voltage range	+IN	-0.20		$V_{DD}+0.20$	V
C_i Input capacitance ⁽²⁾			21		pF
I_{ilk} Input leakage current	$T_A = 125^\circ\text{C}$		40		nA
SYSTEM PERFORMANCE					
Resolution			10		Bits
No missing codes		10			Bits
INL Integral nonlinearity		-1.2	± 0.35	1.2	LSB ⁽³⁾
DNL Differential nonlinearity		-1 ⁽⁴⁾	± 0.35	1.35	LSB
E_O Offset error ^{(5) (6) (7)}		-2.5	± 0.5	2.5	LSB
E_G Gain error ⁽⁶⁾		-2	± 0.5	2	LSB
SAMPLING DYNAMICS					
Conversion time	25-MHz SCLK	530	560		ns
Acquisition time		260			ns
Maximum throughput rate	25-MHz SCLK			1.25	MHz
Aperture delay			5		ns
Step response			160		ns
Overvoltage recovery			160		ns
DYNAMIC CHARACTERISTICS					
THD Total harmonic distortion ⁽⁸⁾	100 kHz		-84	-67	dB
SINAD Signal-to-noise and distortion	100 kHz	59	61		dB
SFDR Spurious free dynamic range	100 kHz	70	81		dB
Full power bandwidth	At -3 dB		15		MHz
DIGITAL INPUT/OUTPUT					
Logic family — CMOS					
V_{IH} High-level input voltage	$V_{DD} = 2.35 \text{ V to } 5.25 \text{ V}$	$V_{DD} - 0.4$		5.25	V
V_{IL} Low-level input voltage	$V_{DD} = 5 \text{ V}$			0.8	V
	$V_{DD} = 3 \text{ V}$			0.4	
V_{OH} High-level output voltage	At $I_{\text{source}} = 200 \mu\text{A}$	$V_{DD}-0.2$			V
V_{OL} Low-level output voltage	At $I_{\text{sink}} = 200 \mu\text{A}$			0.4	
POWER SUPPLY REQUIREMENTS					
$+V_{DD}$ Supply voltage		2.35	3.3	5.25	V
Supply current (normal mode)	At $V_{DD} = 2.35 \text{ V to } 5.25 \text{ V}$, 1.25-MHz throughput			2	mA
	At $V_{DD} = 2.35 \text{ V to } 5.25 \text{ V}$, static state			1.5	
Power-down state supply current	SCLK off			10	μA
	SCLK on (25 MHz)			200	
Power dissipation at 1.25 MHz throughput	$V_{DD} = 5 \text{ V}$		8	10	mW
	$V_{DD} = 3 \text{ V}$		3.8	6	

- (1) Ideal input span; does not include gain or offset error.
- (2) Refer [Figure 21](#) for details on sampling circuit
- (3) LSB means least significant bit
- (4) Exclusive
- (5) Measured relative to an ideal full-scale input
- (6) Offset error and gain error ensured by characterization.
- (7) First transition of 000H to 001H at $0.5 \times (V_{\text{ref}}/2^{10})$
- (8) Calculated on the first nine harmonics of the input frequency

ELECTRICAL SPECIFICATIONS (continued)

+V_{DD} = 2.35 V to 5.25 V, T_A = -55°C to 125°C, f_{sample} = 1.25 MHz

PARAMETER	TEST CONDITIONS	MIN	TYP	MAX	UNIT
Power dissipation in static state	V _{DD} = 5 V		5.5	7.5	mW
	V _{DD} = 3 V		3	4.5	
Power down time				0.1	μs
Power up time				0.8	μs
Invalid conversions after power up				1	
TEMPERATURE RANGE					
Specified performance		-55		125	°C

TIMING REQUIREMENTS (see Figure 1)

All specifications typical at T_A = -55°C to 125°C, V_{DD} = 2.35 V to 5.25 V, unless otherwise specified.

PARAMETER	TEST CONDITIONS ⁽¹⁾	MIN	TYP	MAX	UNIT
t _{conv} Conversion time	V _{DD} = 3 V			14 × t _{SCLK}	ns
	V _{DD} = 5 V			14 × t _{SCLK}	
t _q Minimum quiet time needed from bus 3-state to start of next conversion	V _{DD} = 3 V	40			ns
	V _{DD} = 5 V	40			
t _{d1} Delay time, \overline{CS} low to first data (0) out	V _{DD} = 3 V		15	25	ns
	V _{DD} = 5 V		13	25	
t _{su1} Setup time, \overline{CS} low to SCLK low	V _{DD} = 3 V	10			ns
	V _{DD} = 5 V	10			
t _{d2} Delay time, SCLK falling to SDO	V _{DD} = 3 V		15	25	ns
	V _{DD} = 5 V		13	25	
t _{h1} Hold time, SCLK falling to data valid ⁽²⁾	V _{DD} < 3 V	7			ns
	V _{DD} > 5 V	5.5			
t _{d3} Delay time, 16th SCLK falling edge to SDO 3-state	V _{DD} = 3 V		10	25	ns
	V _{DD} = 5 V		8	20	
t _{w1} Pulse duration, \overline{CS}	V _{DD} = 3 V	25	40		ns
	V _{DD} = 5 V	25	40		
t _{d4} Delay time, \overline{CS} high to SDO 3-state	V _{DD} = 3 V		17	30	ns
	V _{DD} = 5 V		15	25	
t _{wH} Pulse duration, SCLK high	V _{DD} = 3 V	0.4 × t _{SCLK}			ns
	V _{DD} = 5 V	0.4 × t _{SCLK}			
t _{wL} Pulse duration, SCLK low	V _{DD} = 3 V	0.4 × t _{SCLK}			ns
	V _{DD} = 5 V	0.4 × t _{SCLK}			
Frequency, SCLK	V _{DD} = 3 V			25	MHz
	V _{DD} = 5 V			25	
t _{d5} Delay time, second falling edge of clock and \overline{CS} to enter in powerdown (use minimum specification to avoid accidentally entering powerdown) Figure 2	V _{DD} = 3 V	-2		5	ns
	V _{DD} = 5 V	-2		5	
t _{d6} Delay time, \overline{CS} and 10th falling edge of clock to enter in powerdown (use maximum specification to avoid accidentally entering powerdown) Figure 2	V _{DD} = 3 V	2		-5	ns
	V _{DD} = 5 V	2		-5	

(1) 3-V Specifications apply from 2.35 V to 3.6 V, and 5-V specifications apply from 4.75 V to 5.25 V.

(2) With 50-pf load.

DEVICE INFORMATION

SOT23 PACKAGE
(TOP VIEW)

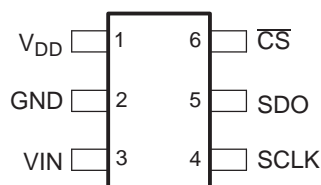

TERMINAL FUNCTIONS

TERMINAL		I/O	DESCRIPTION
NAME	NO.		
V _{DD}	1	–	Power supply input also acts like a reference voltage to ADC.
GND	2	–	Ground for power supply, all analog and digital signals are referred with respect to this pin.
VIN	3	I	Analog signal input
SCLK	4	I	Serial clock
SDO	5	O	Serial data out
$\overline{\text{CS}}$	6	I	Chip select signal, active low

NORMAL OPERATION

The cycle begins with the falling edge of $\overline{\text{CS}}$. This point is indicated as **a** in Figure 1. With the falling edge of $\overline{\text{CS}}$, the input signal is sampled and the conversion process is initiated. The device outputs data while the conversion is in progress. The data word contains 4 leading zeros, followed by 10-bit data in MSB first format and padded by 2 lagging zeros.

The falling edge of $\overline{\text{CS}}$ clocks out the first zero, and a zero is clocked out on every falling edge of the clock until the third edge. Data is in MSB first format with the MSB being clocked out on the 4th falling edge. Data is padded with two lagging zeros as shown in Figure 1. On the 16th falling edge of SCLK, SDO goes to the 3-state condition. The conversion ends on the 14th falling edge of SCLK. The device enters the acquisition phase on the first rising edge of SCLK after the 13th falling edge. This point is indicated by **b** in Figure 1.

$\overline{\text{CS}}$ can be asserted (pulled high) after 16 clocks have elapsed. Do not start the next conversion by pulling $\overline{\text{CS}}$ low until the end of the quiet time (t_q) after SDO goes to 3-state. To continue normal operation, do not pull $\overline{\text{CS}}$ high until point **b**. Without this, the device does not enter the acquisition phase and no valid data is available in the next cycle. (Also refer to power down mode for more details.) $\overline{\text{CS}}$ going high any time after the conversion start aborts the ongoing conversion and SDO goes to 3-state.

The high level of the digital input to the device is not limited to device V_{DD}. This means the digital input can go as high as 5.25 V when the device supply is 2.35 V. This feature is useful when digital signals are coming from another circuit with different supply levels. Also, this relaxes the restriction on power up sequencing. However, the digital output levels (V_{OH} and V_{OL}) are governed by V_{DD} as listed in the SPECIFICATIONS table.

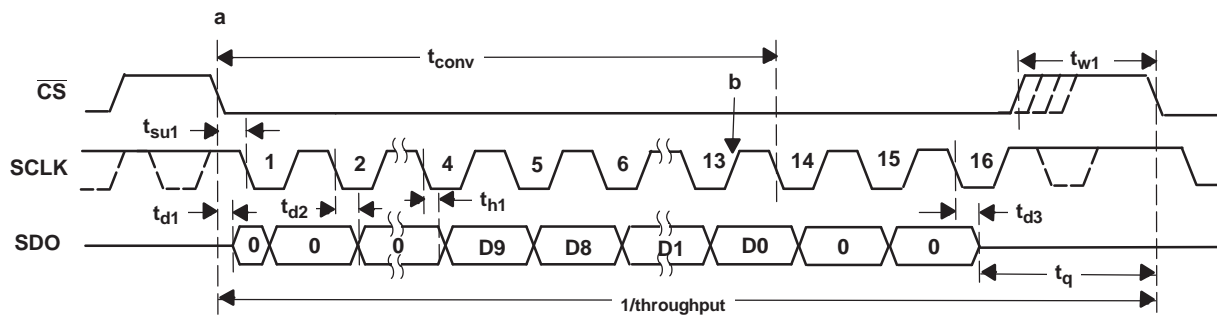

Figure 1. Interface Timing Diagram

POWER-DOWN MODE

The device enters power down mode if \overline{CS} goes high anytime after the second SCLK falling edge to before the tenth SCLK falling edge. Ongoing conversion stops and SDO goes to 3-state under this power-down condition as shown in Figure 2.

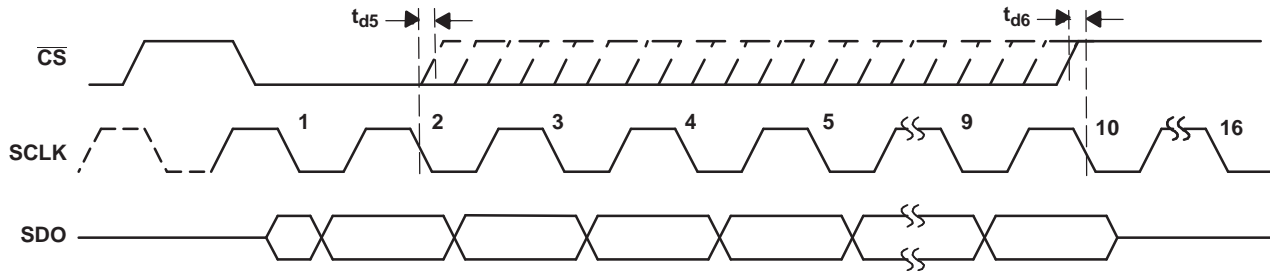

Figure 2. Entering Power Down Mode

A dummy cycle with \overline{CS} low for more than ten SCLK falling edges brings the device out of power-down mode. For the device to come to the fully powered up condition it takes 0.8 μ s. \overline{CS} can be pulled high any time after the 10th falling edge as shown in Figure 3. It is not necessary to continue until the 16th clock if the next conversion starts 0.8 μ s after \overline{CS} going low of the dummy cycle and the quiet time (t_q) condition is met.

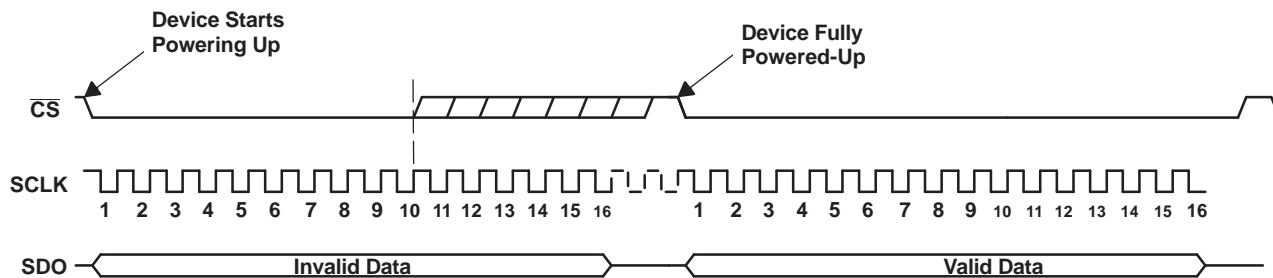

Figure 3. Exiting Power Down Mode

TYPICAL CHARACTERISTICS

SUPPLY CURRENT
VS
SUPPLY VOLTAGE

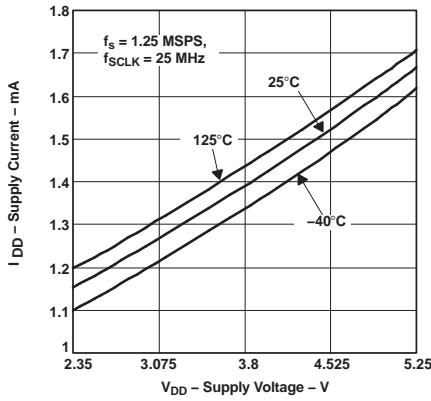

Figure 4.

SUPPLY CURRENT
VS
SCLK FREQUENCY

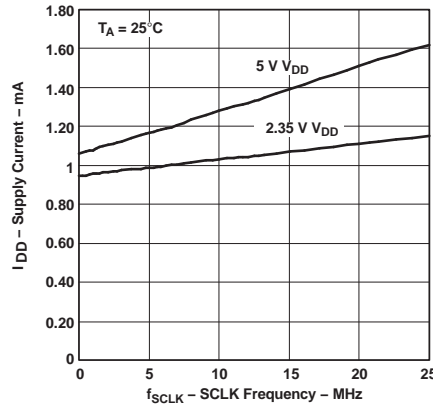

Figure 5.

SUPPLY CURRENT
VS
SAMPLE RATE

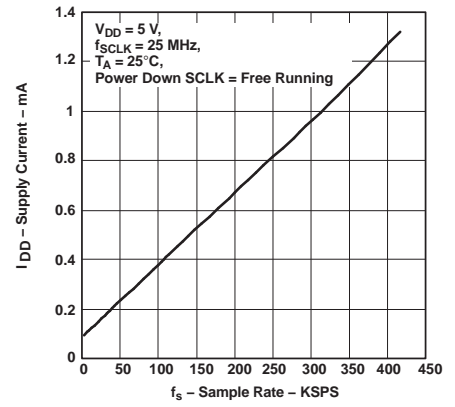

Figure 6.

ANALOG INPUT
LEAKAGE CURRENT
VS
FREE-AIR TEMPERATURE

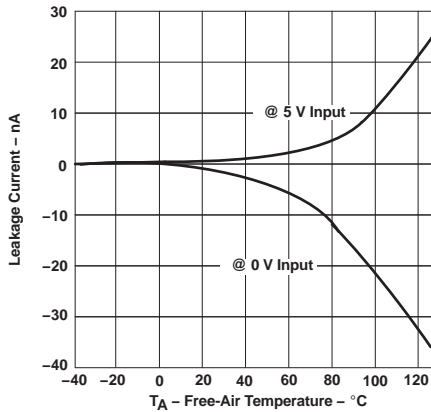

Figure 7.

SIGNAL-TO-NOISE
AND DISTORTION
VS
INPUT FREQUENCY

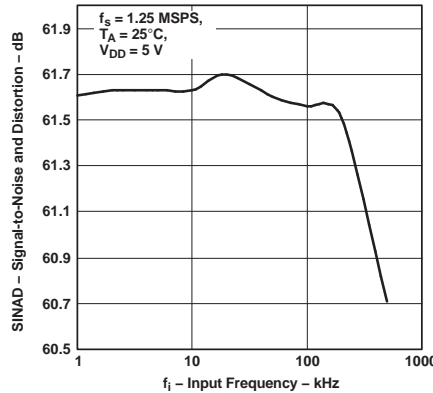

Figure 8.

SIGNAL-TO-NOISE
AND DISTORTION
VS
SUPPLY VOLTAGE

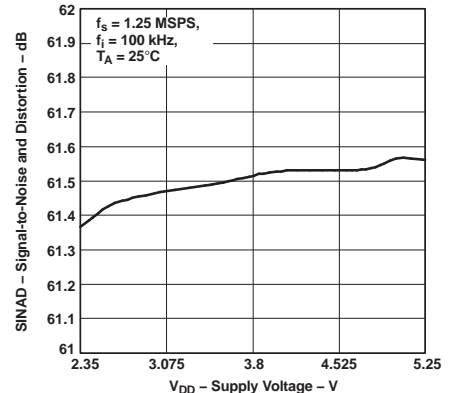

Figure 9.

TOTAL HARMONIC DISTORTION
VS
INPUT FREQUENCY

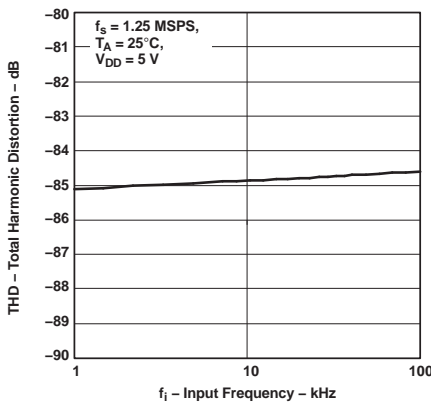

Figure 10.

TOTAL HARMONIC DISTORTION
VS
SUPPLY VOLTAGE

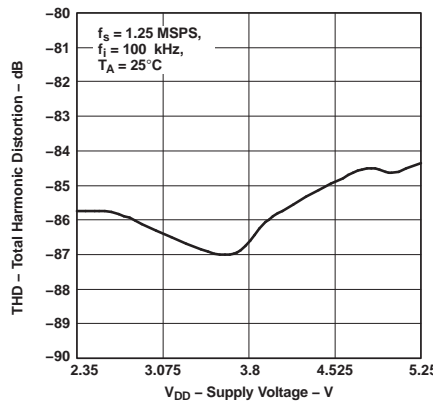

Figure 11.

SPURIOUS FREE DYNAMIC RANGE
VS
INPUT FREQUENCY

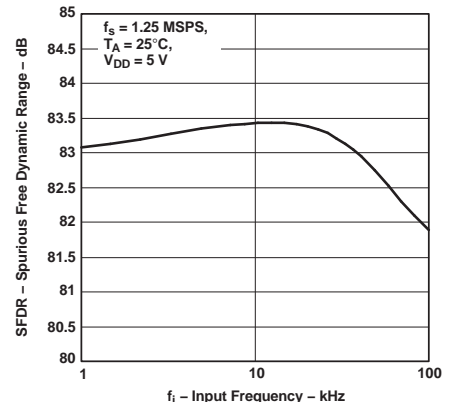

Figure 12.

TYPICAL CHARACTERISTICS (continued)

**SPURIOUS FREE DYNAMIC RANGE
vs
SUPPLY VOLTAGE**

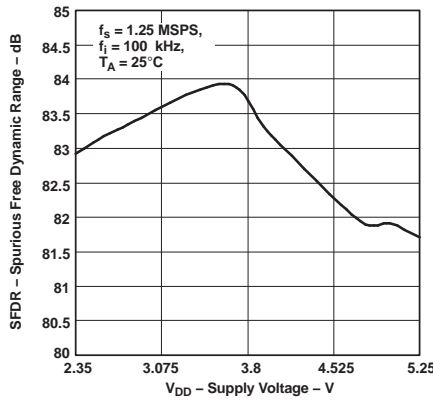

Figure 13.

**OFFSET ERROR
vs
SUPPLY VOLTAGE**

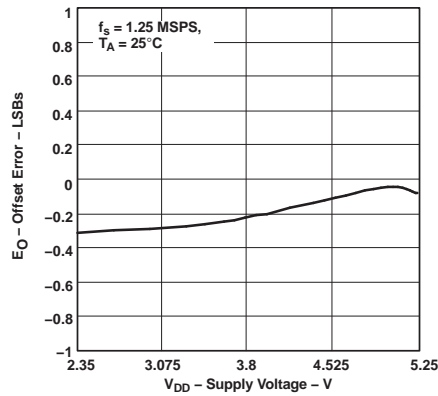

Figure 14.

**OFFSET ERROR
vs
FREE-AIR TEMPERATURE**

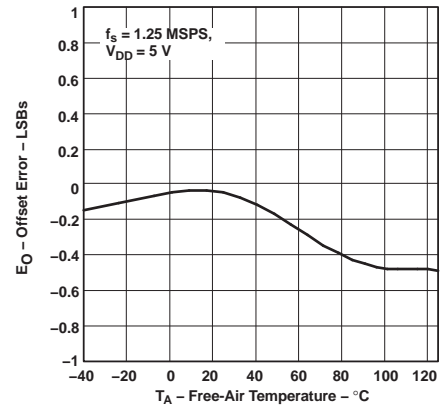

Figure 15.

**GAIN ERROR
vs
SUPPLY VOLTAGE**

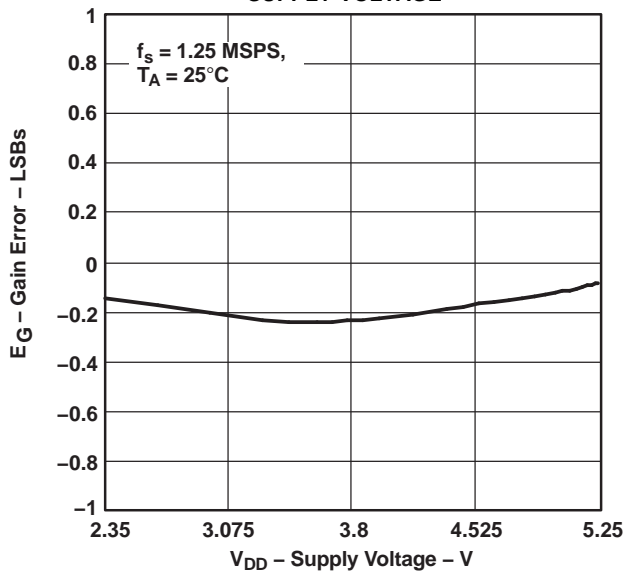

Figure 16.

**GAIN ERROR
vs
FREE-AIR TEMPERATURE**

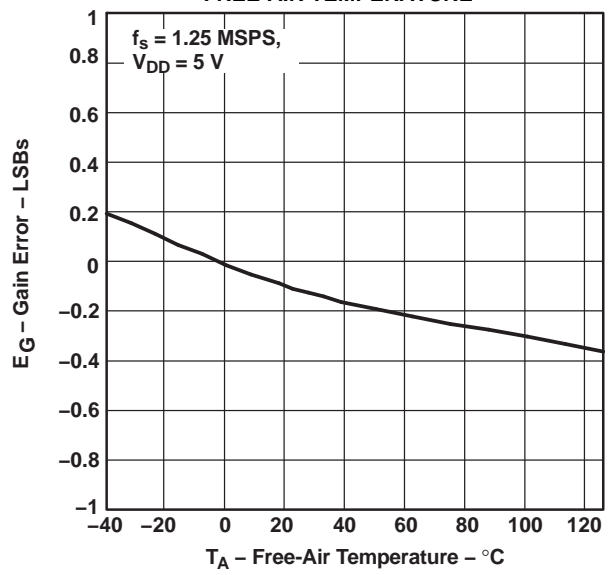

Figure 17.

TYPICAL CHARACTERISTICS (continued)

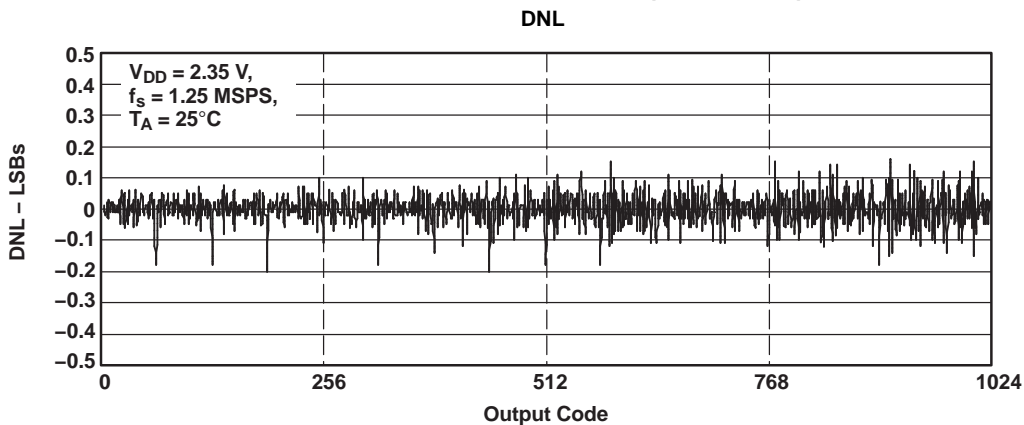

Figure 18.

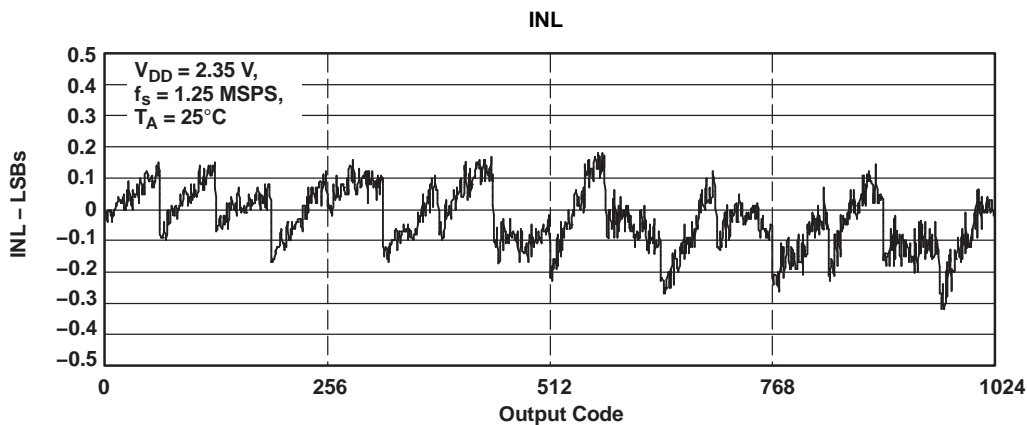

Figure 19.

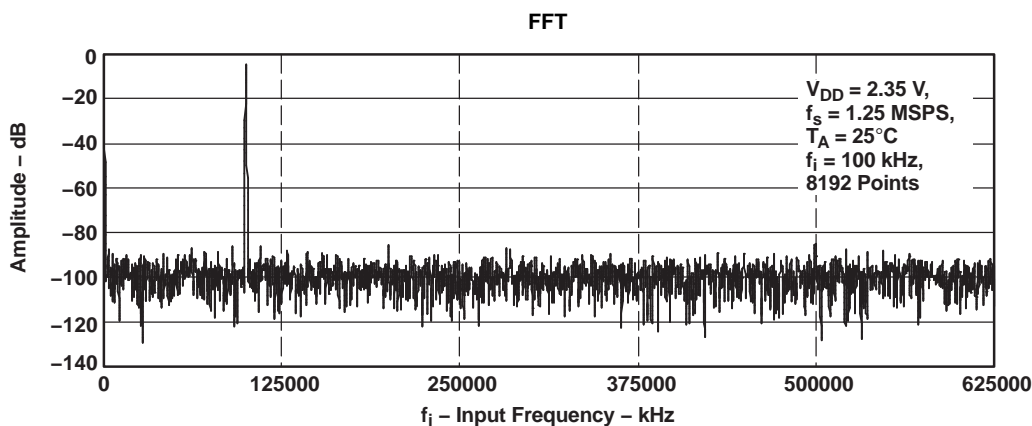

Figure 20.

APPLICATION INFORMATION

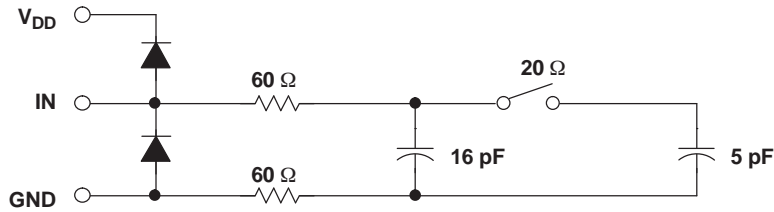

Figure 21. Typical Equivalent Sampling Circuit

Driving the VIN and V_{DD} Pins

The VIN input to the ADS7887 should be driven with a low-impedance source. In most cases, additional buffers are not required. In cases where the source impedance exceeds 200 Ω, using a buffer helps achieve the rated performance of the converter. The THS4031 is a good choice for the driver amplifier buffer.

The reference voltage for the ADS7887 A/D converter is derived internally from the supply voltage. The device offer limited low-pass filtering functionality on-chip. The supply to the converter should be driven with a low-impedance source and should be decoupled to ground. A 1-μF storage capacitor and a 10-nF decoupling capacitor should be placed close to the device. Wide low-impedance traces should be used to connect the capacitor to the pins of the device. The ADS7887 draws very little current from the supply lines. The supply line can be driven:

- Directly from the system supply.
- From a reference output from a low-drift and low-dropout reference voltage generator like REF3030 or REF3130. The ADS7887 can operate off a wide range of supply voltages. The actual choice of the reference voltage generator depends upon the system. Figure 23 shows one possible application circuit.
- A low-pass filtered version of the system supply followed by a buffer such as the zero-drift OPA735 can also be used in cases where the system power supply is noisy. Care should be taken to ensure that the voltage at the V_{DD} input does not exceed 7 V (especially during power up) to avoid damage to the converter. This can be done easily using single supply CMOS amplifiers like the OPA735. Figure 24 shows one possible application circuit.

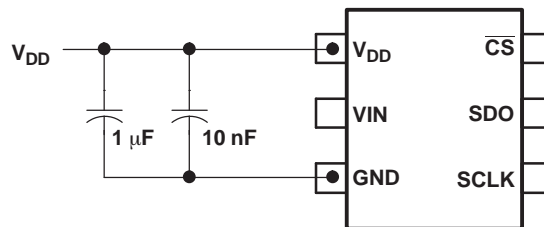

Figure 22. Supply/Reference Decoupling Capacitors

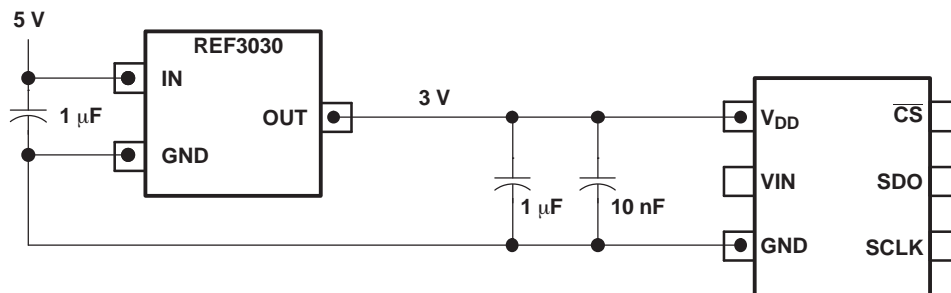

Figure 23. Using the REF3030 Reference

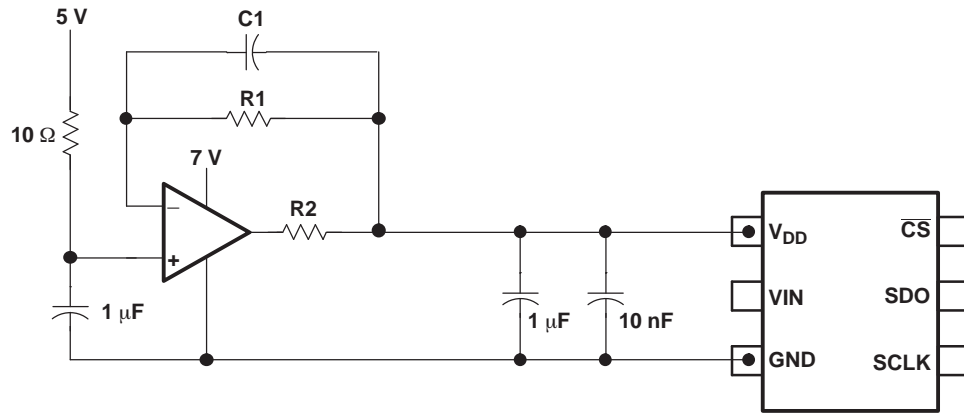

Figure 24. Buffering with the OPA735

PACKAGING INFORMATION

Orderable Device	Status (1)	Package Type	Package Drawing	Pins	Package Qty	Eco Plan (2)	Lead/Ball Finish (6)	MSL Peak Temp (3)	Op Temp (°C)	Device Marking (4/5)	Samples
ADS7887MDBVT	NRND	SOT-23	DBV	6	250	Pb-Free (RoHS Exempt)	CU SN	Level-2-260C-1 YEAR	-55 to 125	BCNM	

(1) The marketing status values are defined as follows:

ACTIVE: Product device recommended for new designs.

LIFEBUY: TI has announced that the device will be discontinued, and a lifetime-buy period is in effect.

NRND: Not recommended for new designs. Device is in production to support existing customers, but TI does not recommend using this part in a new design.

PREVIEW: Device has been announced but is not in production. Samples may or may not be available.

OBSELETE: TI has discontinued the production of the device.

(2) **RoHS:** TI defines "RoHS" to mean semiconductor products that are compliant with the current EU RoHS requirements for all 10 RoHS substances, including the requirement that RoHS substance do not exceed 0.1% by weight in homogeneous materials. Where designed to be soldered at high temperatures, "RoHS" products are suitable for use in specified lead-free processes. TI may reference these types of products as "Pb-Free".

RoHS Exempt: TI defines "RoHS Exempt" to mean products that contain lead but are compliant with EU RoHS pursuant to a specific EU RoHS exemption.

Green: TI defines "Green" to mean the content of Chlorine (Cl) and Bromine (Br) based flame retardants meet JS709B low halogen requirements of <=1000ppm threshold. Antimony trioxide based flame retardants must also meet the <=1000ppm threshold requirement.

(3) MSL, Peak Temp. - The Moisture Sensitivity Level rating according to the JEDEC industry standard classifications, and peak solder temperature.

(4) There may be additional marking, which relates to the logo, the lot trace code information, or the environmental category on the device.

(5) Multiple Device Markings will be inside parentheses. Only one Device Marking contained in parentheses and separated by a "~" will appear on a device. If a line is indented then it is a continuation of the previous line and the two combined represent the entire Device Marking for that device.

(6) Lead/Ball Finish - Orderable Devices may have multiple material finish options. Finish options are separated by a vertical ruled line. Lead/Ball Finish values may wrap to two lines if the finish value exceeds the maximum column width.

Important Information and Disclaimer:The information provided on this page represents TI's knowledge and belief as of the date that it is provided. TI bases its knowledge and belief on information provided by third parties, and makes no representation or warranty as to the accuracy of such information. Efforts are underway to better integrate information from third parties. TI has taken and continues to take reasonable steps to provide representative and accurate information but may not have conducted destructive testing or chemical analysis on incoming materials and chemicals. TI and TI suppliers consider certain information to be proprietary, and thus CAS numbers and other limited information may not be available for release.

In no event shall TI's liability arising out of such information exceed the total purchase price of the TI part(s) at issue in this document sold by TI to Customer on an annual basis.

OTHER QUALIFIED VERSIONS OF ADS7887M :

- Catalog: [ADS7887](#)

NOTE: Qualified Version Definitions:

- Catalog - TI's standard catalog product

TAPE AND REEL INFORMATION



QUADRANT ASSIGNMENTS FOR PIN 1 ORIENTATION IN TAPE



*All dimensions are nominal

Device	Package Type	Package Drawing	Pins	SPQ	Reel Diameter (mm)	Reel Width W1 (mm)	A0 (mm)	B0 (mm)	K0 (mm)	P1 (mm)	W (mm)	Pin1 Quadrant
ADS7887MDBVT	SOT-23	DBV	6	250	177.8	9.7	3.2	3.1	1.39	4.0	8.0	Q3

TAPE AND REEL BOX DIMENSIONS



*All dimensions are nominal

Device	Package Type	Package Drawing	Pins	SPQ	Length (mm)	Width (mm)	Height (mm)
ADS7887MDBVT	SOT-23	DBV	6	250	184.0	184.0	50.0

MECHANICAL DATA

DBV (R-PDSO-G6)

PLASTIC SMALL-OUTLINE PACKAGE

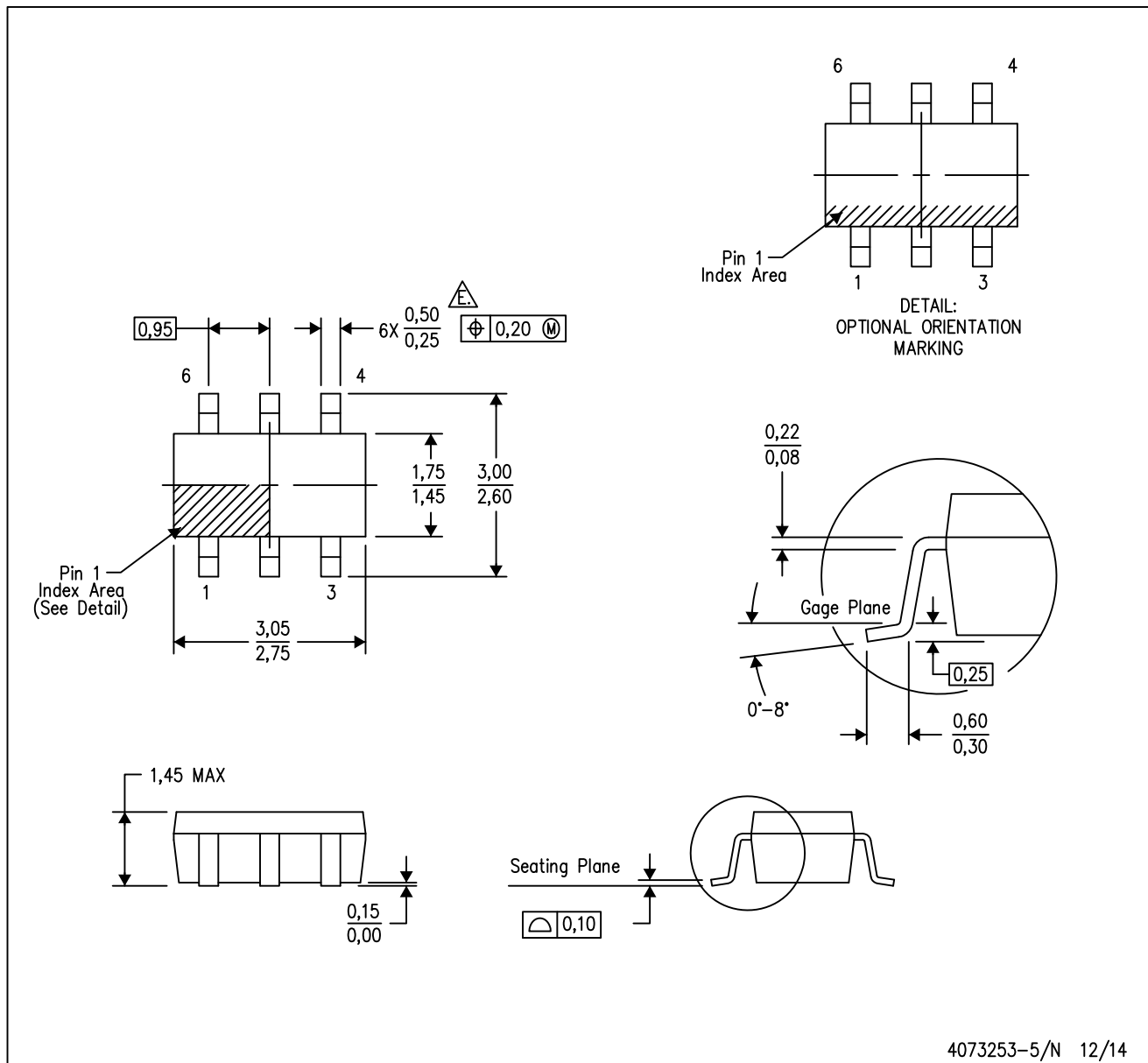

- NOTES:
- A. All linear dimensions are in millimeters.
 - B. This drawing is subject to change without notice.
 - C. Body dimensions do not include mold flash or protrusion. Mold flash and protrusion shall not exceed 0.15 per side.
 - D. Leads 1,2,3 may be wider than leads 4,5,6 for package orientation.
-  Falls within JEDEC MO-178 Variation AB, except minimum lead width.

DBV (R-PDSO-G6)

PLASTIC SMALL OUTLINE

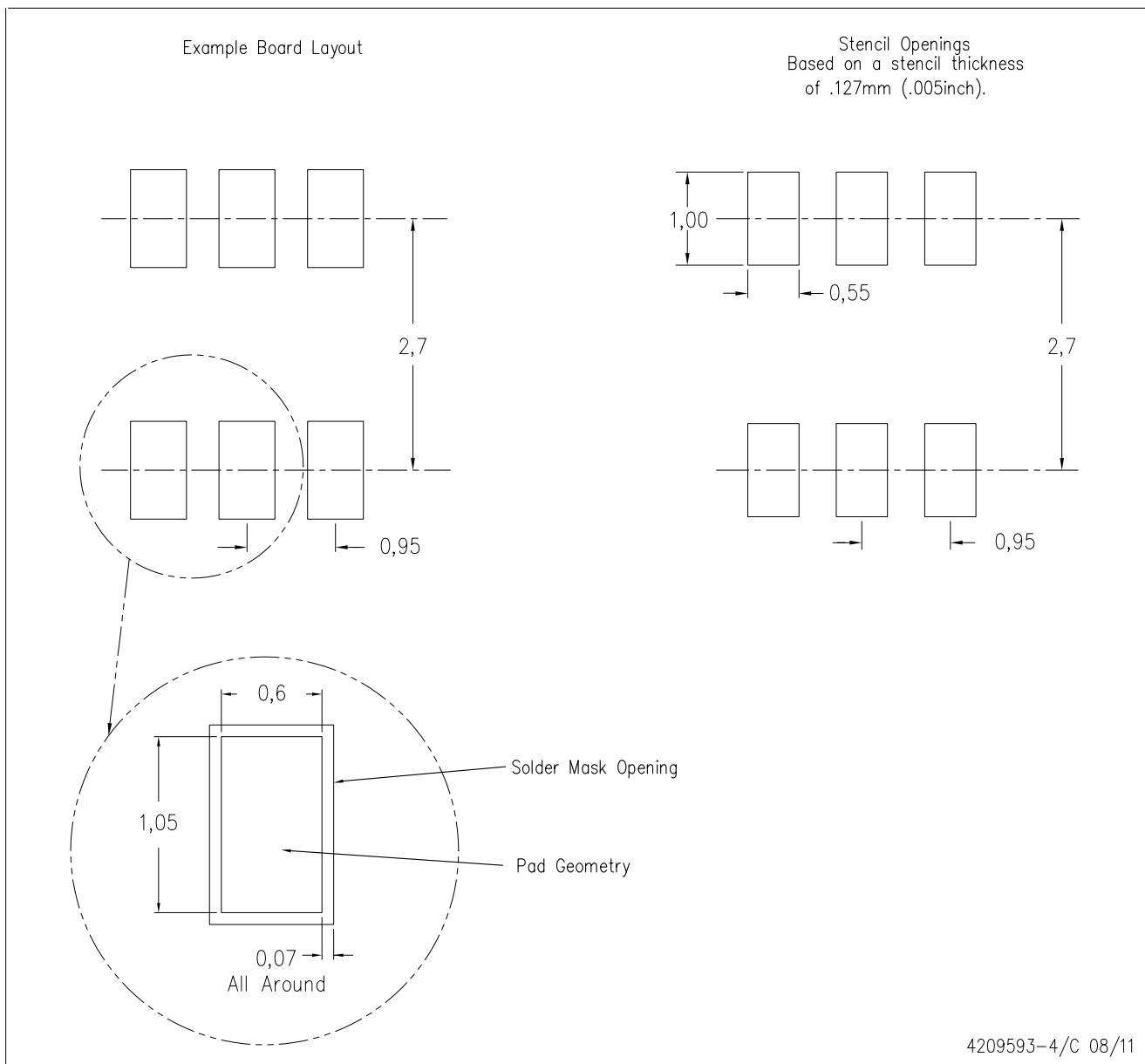

- NOTES:
- A. All linear dimensions are in millimeters.
 - B. This drawing is subject to change without notice.
 - C. Customers should place a note on the circuit board fabrication drawing not to alter the center solder mask defined pad.
 - D. Publication IPC-7351 is recommended for alternate designs.
 - E. Laser cutting apertures with trapezoidal walls and also rounding corners will offer better paste release. Customers should contact their board assembly site for stencil design recommendations. Example stencil design based on a 50% volumetric metal load solder paste. Refer to IPC-7525 for other stencil recommendations.

IMPORTANT NOTICE

Texas Instruments Incorporated (TI) reserves the right to make corrections, enhancements, improvements and other changes to its semiconductor products and services per JESD46, latest issue, and to discontinue any product or service per JESD48, latest issue. Buyers should obtain the latest relevant information before placing orders and should verify that such information is current and complete.

TI's published terms of sale for semiconductor products (<http://www.ti.com/sc/docs/stdterms.htm>) apply to the sale of packaged integrated circuit products that TI has qualified and released to market. Additional terms may apply to the use or sale of other types of TI products and services.

Reproduction of significant portions of TI information in TI data sheets is permissible only if reproduction is without alteration and is accompanied by all associated warranties, conditions, limitations, and notices. TI is not responsible or liable for such reproduced documentation. Information of third parties may be subject to additional restrictions. Resale of TI products or services with statements different from or beyond the parameters stated by TI for that product or service voids all express and any implied warranties for the associated TI product or service and is an unfair and deceptive business practice. TI is not responsible or liable for any such statements.

Buyers and others who are developing systems that incorporate TI products (collectively, "Designers") understand and agree that Designers remain responsible for using their independent analysis, evaluation and judgment in designing their applications and that Designers have full and exclusive responsibility to assure the safety of Designers' applications and compliance of their applications (and of all TI products used in or for Designers' applications) with all applicable regulations, laws and other applicable requirements. Designer represents that, with respect to their applications, Designer has all the necessary expertise to create and implement safeguards that (1) anticipate dangerous consequences of failures, (2) monitor failures and their consequences, and (3) lessen the likelihood of failures that might cause harm and take appropriate actions. Designer agrees that prior to using or distributing any applications that include TI products, Designer will thoroughly test such applications and the functionality of such TI products as used in such applications.

TI's provision of technical, application or other design advice, quality characterization, reliability data or other services or information, including, but not limited to, reference designs and materials relating to evaluation modules, (collectively, "TI Resources") are intended to assist designers who are developing applications that incorporate TI products; by downloading, accessing or using TI Resources in any way, Designer (individually or, if Designer is acting on behalf of a company, Designer's company) agrees to use any particular TI Resource solely for this purpose and subject to the terms of this Notice.

TI's provision of TI Resources does not expand or otherwise alter TI's applicable published warranties or warranty disclaimers for TI products, and no additional obligations or liabilities arise from TI providing such TI Resources. TI reserves the right to make corrections, enhancements, improvements and other changes to its TI Resources. TI has not conducted any testing other than that specifically described in the published documentation for a particular TI Resource.

Designer is authorized to use, copy and modify any individual TI Resource only in connection with the development of applications that include the TI product(s) identified in such TI Resource. NO OTHER LICENSE, EXPRESS OR IMPLIED, BY ESTOPPEL OR OTHERWISE TO ANY OTHER TI INTELLECTUAL PROPERTY RIGHT, AND NO LICENSE TO ANY TECHNOLOGY OR INTELLECTUAL PROPERTY RIGHT OF TI OR ANY THIRD PARTY IS GRANTED HEREIN, including but not limited to any patent right, copyright, mask work right, or other intellectual property right relating to any combination, machine, or process in which TI products or services are used. Information regarding or referencing third-party products or services does not constitute a license to use such products or services, or a warranty or endorsement thereof. Use of TI Resources may require a license from a third party under the patents or other intellectual property of the third party, or a license from TI under the patents or other intellectual property of TI.

TI RESOURCES ARE PROVIDED "AS IS" AND WITH ALL FAULTS. TI DISCLAIMS ALL OTHER WARRANTIES OR REPRESENTATIONS, EXPRESS OR IMPLIED, REGARDING RESOURCES OR USE THEREOF, INCLUDING BUT NOT LIMITED TO ACCURACY OR COMPLETENESS, TITLE, ANY EPIDEMIC FAILURE WARRANTY AND ANY IMPLIED WARRANTIES OF MERCHANTABILITY, FITNESS FOR A PARTICULAR PURPOSE, AND NON-INFRINGEMENT OF ANY THIRD PARTY INTELLECTUAL PROPERTY RIGHTS. TI SHALL NOT BE LIABLE FOR AND SHALL NOT DEFEND OR INDEMNIFY DESIGNER AGAINST ANY CLAIM, INCLUDING BUT NOT LIMITED TO ANY INFRINGEMENT CLAIM THAT RELATES TO OR IS BASED ON ANY COMBINATION OF PRODUCTS EVEN IF DESCRIBED IN TI RESOURCES OR OTHERWISE. IN NO EVENT SHALL TI BE LIABLE FOR ANY ACTUAL, DIRECT, SPECIAL, COLLATERAL, INDIRECT, PUNITIVE, INCIDENTAL, CONSEQUENTIAL OR EXEMPLARY DAMAGES IN CONNECTION WITH OR ARISING OUT OF TI RESOURCES OR USE THEREOF, AND REGARDLESS OF WHETHER TI HAS BEEN ADVISED OF THE POSSIBILITY OF SUCH DAMAGES.

Unless TI has explicitly designated an individual product as meeting the requirements of a particular industry standard (e.g., ISO/TS 16949 and ISO 26262), TI is not responsible for any failure to meet such industry standard requirements.

Where TI specifically promotes products as facilitating functional safety or as compliant with industry functional safety standards, such products are intended to help enable customers to design and create their own applications that meet applicable functional safety standards and requirements. Using products in an application does not by itself establish any safety features in the application. Designers must ensure compliance with safety-related requirements and standards applicable to their applications. Designer may not use any TI products in life-critical medical equipment unless authorized officers of the parties have executed a special contract specifically governing such use. Life-critical medical equipment is medical equipment where failure of such equipment would cause serious bodily injury or death (e.g., life support, pacemakers, defibrillators, heart pumps, neurostimulators, and implantables). Such equipment includes, without limitation, all medical devices identified by the U.S. Food and Drug Administration as Class III devices and equivalent classifications outside the U.S.

TI may expressly designate certain products as completing a particular qualification (e.g., Q100, Military Grade, or Enhanced Product). Designers agree that it has the necessary expertise to select the product with the appropriate qualification designation for their applications and that proper product selection is at Designers' own risk. Designers are solely responsible for compliance with all legal and regulatory requirements in connection with such selection.

Designer will fully indemnify TI and its representatives against any damages, costs, losses, and/or liabilities arising out of Designer's non-compliance with the terms and provisions of this Notice.

Looking for pricing, stock, or lifecycle information?

Click below to explore more details on WIN SOURCE:

 [View APTF1616LSEKJ3ZGKQBC on WIN SOURCE](#)

 [Kingbright Information](#)

Optimize Your Supply Chain with WIN SOURCE Solutions

-  Global Sourcing Solution
-  Obsolete Management
-  Cost Control Management
-  Shortage Management
-  Alternative Solution
-  Excess Inventory Management