



Please note that Cypress is an Infineon Technologies Company.

The document following this cover page is marked as “Cypress” document as this is the company that originally developed the product. Please note that Infineon will continue to offer the product to new and existing customers as part of the Infineon product portfolio.

Continuity of document content

The fact that Infineon offers the following product as part of the Infineon product portfolio does not lead to any changes to this document. Future revisions will occur when appropriate, and any changes will be set out on the document history page.

Continuity of ordering part numbers

Infineon continues to support existing part numbers. Please continue to use the ordering part numbers listed in the datasheet for ordering.



PRELIMINARY

CYW4373

Single-Chip Dual Band WiFi IEEE 802.11 a/b/g/n/ac MAC/Baseband/Radio with Integrated Bluetooth 5.0

The Cypress CYW4373 single-chip device provides the highest level of integration for embedded and IoT wireless systems with integrated single-stream IEEE 802.11a/b/g/n/ac MAC/baseband/radio and Bluetooth 5.0 (Basic Rate, Enhanced Data Rate and Bluetooth Low Energy).

CYW4373 supports all rates specified in the IEEE 802.11 a/b/g/n/ac specifications. IEEE 802.11ac's 256-QAM is supported for MCS8 in 20 MHz channels and MCS8/MCS9 in 40 MHz & 80 MHz channels to enable data rates of up to 433.3 Mbps. Included on-chip are 2.4 GHz and 5 GHz power amplifiers and low-noise amplifiers.

The WLAN section supports the following host interface options: an SDIO v3.0 interface that can operate in 4b or 1b mode and a USB 2.0 interface. The Bluetooth section supports USB 2.0, USB 1.1, SDIO and a high-speed 4-wire UART interface. An on-chip USB 2.0 hub provides a shared single USB connection to both WLAN and Bluetooth target devices.

Using advanced design techniques and process technology to reduce active and idle power, the CYW4373 is designed to address the need of mobile devices that require minimal power consumption and compact size. It includes a power management unit (PMU) which simplifies the system power topology and allows for direct operation from a mobile platform battery while maximizing battery life.

The CYW4373 implements highly sophisticated enhanced collaborative coexistence hardware mechanisms and algorithms, which ensure that WLAN and Bluetooth collaboration is optimized for maximum performance. In addition, coexistence support for external radios (such as LTE cellular and ZigBee) is provided via an external interface. As a result, enhanced overall quality for simultaneous voice, video, and data transmission on an embedded and IoT system is achieved.

Features

IEEE 802.11x Key Features

- IEEE 802.11ac compliant.
- Support for MCS8 VHT20 in 20 MHz channels for up to 86.7 Mbps data.
- Single-stream spatial multiplexing up to 433.3 Mbps data rate.
- Supports 20, 40, and 80 MHz channels with optional SGI (256 QAM modulation).
- Full IEEE 802.11a/b/g/n legacy compatibility with enhanced performance.
- On-chip power amplifiers and low-noise amplifiers for both bands.
- Support for optional front-end modules (FEM) with external PAs and LNAs.
- Supports integrated T/R switch for 2.4 GHz band.
- Supports RF front-end architecture with a single dual-band antenna shared between Bluetooth and WLAN for lowest system cost.
- Shared Bluetooth and WLAN receive signal path eliminates the need for an external power splitter while maintaining excellent sensitivity for both Bluetooth and WLAN.
- Supports IEEE 802.15.2 external coexistence interface to optimize bandwidth utilization with other co-located wireless technologies such as LTE or ZigBee.

- Supports standard SDIO v3.0 (including DDR50 mode at 50 MHz and SDR104 mode at 208 MHz, 4-bit and 1-bit) interfaces.
- Backward compatible with SDIO v2.0 host interfaces.
- USB 2.0 high-speed (480 Mbps) with integrated USB hub.
- Integrated Arm Cortex R4 processor and with tightly coupled memory for complete WLAN subsystem functionality and minimizing the need to wake-up the applications processor for standard WLAN functions. This allows for further minimization of power consumption, while maintaining the ability to field upgrade with future features. On-chip memory for WLAN core includes 896 KB RAM and 896 KB ROM.
- Integrated Arm Cortex M3 processor that runs software from the Link Control (LC) to the Host Controller Interface (HCI) layer for Bluetooth. The Arm core is paired with a memory unit that contains 1088 KB of ROM and 384 KB of RAM.
- OneDriver™ software architecture for easy migration from existing embedded WLAN and Bluetooth devices as well as future devices.

Bluetooth Key Features

- Qualified for Bluetooth Core Specification 5.0 with all Bluetooth 4.2 optional features
 - QDID: [102901](#)
 - Declaration ID: [D035922](#)
- Bluetooth Class 1 or Class 2 transmitter operation.

- Supports extended synchronous connections (eSCO), for enhanced voice quality by allowing for retransmission of dropped packets.
 - Adaptive frequency hopping (AFH) for reducing radio frequency interference.
 - Interface support, host controller interface (HCI) using a high-speed UART interface and PCM for audio data.
 - Low power consumption improves battery life of IoT and embedded devices.
 - Supports multiple simultaneous Advanced Audio Distribution Profiles (A2DP) for stereo sound.
 - Automatic frequency detection for standard crystal and TCXO values.
 - Programmable dynamic power management
 - 6 Kbit OTP for storing board parameters.
 - GPIOs: 10.
 - 128-ball WLBGA package (4.51 mm × 5.43 mm, 0.4 mm pitch).
 - Security:
 - WPA and WPA2 (Personal) support for powerful encryption and authentication.
 - AES and TKIP in hardware for faster data encryption and IEEE 802.11i compatibility.
 - Reference WLAN subsystem provides Wi-Fi Protected Setup (WPS).
 - Worldwide regulatory support: Global products supported with worldwide homologated design.
- General Features**
- Supports battery voltage range from 3.2 V to 4.8 V supplies with internal switching regulator.

Figure 1. Functional Block Diagram

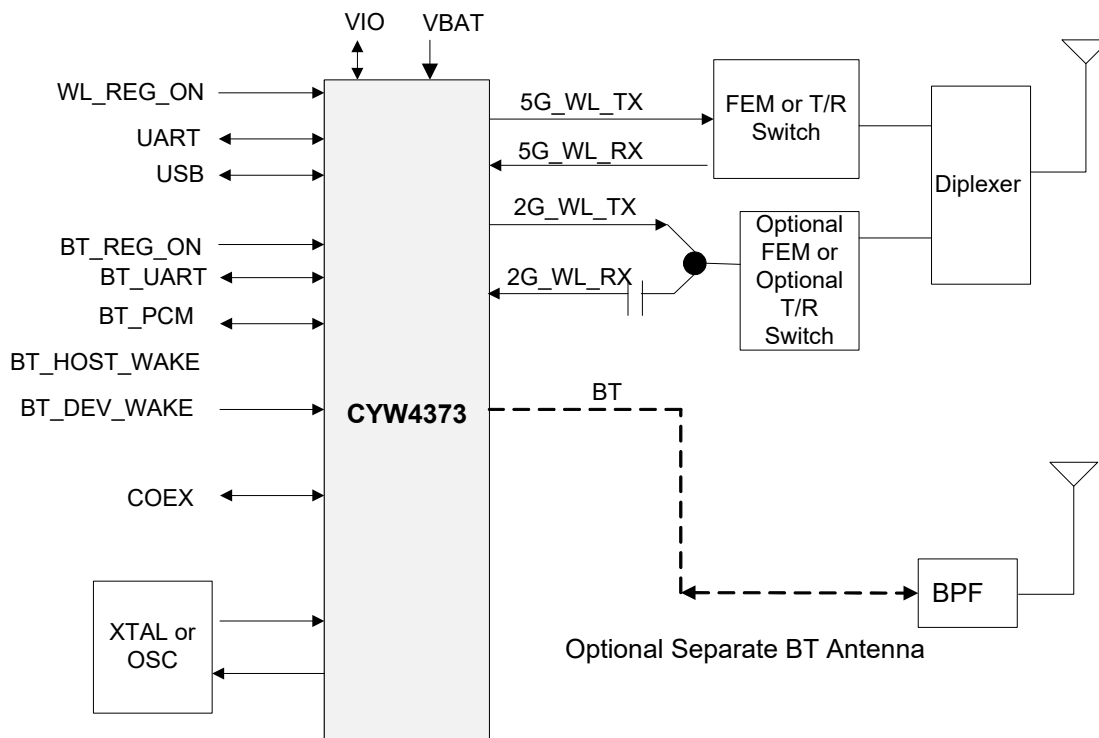

Contents

1. CYW4373 Overview.....	5		
1.1 Overview	5	7.1.1 Slot Mapping	27
1.2 Standards Compliance	6	7.1.2 Frame Synchronization	27
2. Power Supplies and Power Management.....	7	7.1.3 Data Formatting	27
2.1 Power Supply Topology	7	7.1.4 Wideband Speech Support	27
2.2 CYW4373 PMU Features	7	7.1.5 Multiplexed Bluetooth Over PCM	28
2.3 WLAN Power Management	10	7.1.6 Burst PCM Mode	28
2.4 PMU Sequencing	11	7.1.7 PCM Interface Timing	29
2.5 Power-Off Shutdown	11	7.2 UART Interface	34
2.6 Power-Up/Power-Down/Reset Circuits	12	7.3 I ² S Interface	36
3. Frequency References	13	7.3.1 I ² S Timing	37
3.1 Crystal Interface and Clock Generation	13	7.4 BT USB Interface	39
3.2 External Frequency Reference	13	8. WLAN Global Functions.....	40
3.3 External 32.768 kHz Low-Power Oscillator	15	8.1 WLAN CPU and Memory Subsystem	40
4. Bluetooth Overview	16	8.2 One-Time Programmable Memory	40
4.1 Features	16	8.3 GPIO Interface	40
4.2 Bluetooth Radio	17	8.4 External Coexistence Interface	41
4.2.1 Transmit	17	8.4.1 LTE Coexistence Interface	41
4.2.2 Digital Modulator	17	8.4.2 3-Wire (Zigbee) Coexistence Interface	41
4.2.3 Digital Demodulator and Bit Synchronizer	17	8.5 UART Interface	43
4.2.4 Power Amplifier	17	8.6 JTAG Interface	43
4.2.5 Receiver	17	9. WLAN Host Interfaces	44
4.2.6 Digital Demodulator and Bit Synchronizer	17	9.1 WLAN USB 2.0 Interface	44
4.2.7 Receiver Signal Strength Indicator	17	9.2 SDIO v3.0	44
4.2.8 Local Oscillator (LO) Generation	18	9.2.1 SDIO Pins	45
4.2.9 Calibration	18	10. Shared Host Interfaces.....	46
5. Bluetooth Baseband Core (BBC).....	19	10.1 Shared BT and WLAN USB 2.0 Interface	46
5.1 Bluetooth 5.0 Features	19	11. Wireless LAN MAC and PHY.....	47
5.2 Bluetooth 4.0 Features	19	11.1 IEEE 802.11ac MAC	47
5.3 Bluetooth 5.0 Features	19	11.1.1 Programmable State Machine (PSM)	48
5.4 Bluetooth Low Energy	19	11.1.2 Wired Equivalent Privacy (WEP)	48
5.5 Link Control Layer (LCU)	20	11.1.3 Transmit Engine (TXE)	48
5.6 Test Mode Support	20	11.1.4 Receive Engine (RXE)	48
5.7 Bluetooth Power Management Unit	21	11.1.5 Interframe Space (IFS) timing	48
5.7.1 RF Power Management	21	11.1.6 Timing Synchronization function (TSF)	49
5.7.2 Host Controller Power Management	21	11.1.7 Network Allocation Vector (NAV)	49
5.7.3 BBC Power Management	23	11.1.8 MAC-PHY Interface	49
5.8 Adaptive Frequency Hopping	24	11.2 IEEE 802.11ac PHY	50
5.9 Advanced Bluetooth/WLAN Coexistence	25	12. WLAN Radio Subsystem.....	52
5.10 Fast Connection (Interlaced Page and Inquiry Scans)	25	12.1 Receiver Path	52
6. Microprocessor and Memory Unit for Bluetooth	26	12.2 Transmit Path	52
6.1 RAM, ROM, and Patch Memory	26	12.3 Calibration	52
6.2 Reset	26	13. Ball Map and Pin Descriptions	54
7. Bluetooth Peripheral Transport Unit.....	27	13.1 Ball Map	54
7.1 PCM Interface	27	13.2 Pin List by Pin Number	55
		13.3 Pin Descriptions	57
		13.4 WLAN GPIO Signals and Strapping Options	61
		13.5 XTAL Selection Table for WLPGA in USB mode	61
		13.5.1 Multiplexed WLAN GPIO signals	62

13.6 I/O States	64	18.1.1 2.4 GHz Mode	93
14. DC Characteristics	67	18.1.2 5 GHz Mode	94
14.1 Absolute Maximum Ratings	67	18.2 Bluetooth Current Consumption	95
14.2 Environmental Ratings	67	19. Interface Timing and AC Characteristics	96
14.3 Electrostatic Discharge Specifications	67	19.1 SDIO Timing	96
14.4 Recommended Operating Conditions and DC Characteristics	68	19.1.1 SDIO Default Mode Timing	96
15. Bluetooth RF Specifications	69	19.1.2 SDIO High-Speed Mode Timing	97
16. WLAN RF Specifications	75	19.1.3 SDIO Bus Timing Specifications in SDR Modes	98
16.1 Introduction	75	19.1.4 SDIO Bus Timing Specifications in DDR50 Mode	102
16.2 WLAN 2.4 GHz Receiver Performance Specifications	76	19.2 JTAG Timing	104
16.3 WLAN 2.4 GHz Transmitter Performance Specifications	79	20. Power-Up Sequence and Timing	105
16.4 WLAN 5 GHz Receiver Performance Specifications	80	20.1 Sequencing of Reset and Regulator Control Signals	105
16.5 WLAN 5 GHz Transmitter Performance Specifications	83	20.1.1 Description of Control Signals	105
16.6 .General Spurious Emissions Specifications	84	20.1.2 Control Signal Timing Diagrams	105
16.6.1 2.4 GHz Band Spurious Emissions	84	21. Package Information	107
16.6.2 5 GHz Band Spurious Emissions	85	21.1 Package Thermal Characteristics	107
16.6.3 Receiver Spurious Emissions Specifications	86	21.2 Junction Temperature Estimation and Y_{JT} Versus q_{JC}	107
17. Internal Regulator Electrical Specifications. 87		21.3 Environmental Characteristics	107
17.1 Core Buck Switching Regulator	87	22. Mechanical Information.....	108
17.2 3.3V LDO (LDO3P3)	88	23. Ordering Information.....	110
17.3 2.5V LDO (BTLDO2P5)	89	24. Additional Information	110
17.4 CLDO	90	24.1 Acronyms and Abbreviations	110
17.5 LNLDO	91	24.2 References	111
17.6 HLDO	92	24.3 IoT Resources	111
18. System Power Consumption	93	24.4 Errata	111
18.1 WLAN Current Consumption	93	Document History	112
		Sales, Solutions, and Legal Information	115

1. CYW4373 Overview

1.1 Overview

The Cypress CYW4373 single-chip device provides the highest level of integration for any embedded wireless system, with integrated IEEE 802.11 a/b/g/n/ac MAC/baseband radio and Bluetooth 5.0. It provides a small form-factor solution with minimal external components to drive down cost for mass volumes and allows for flexibility in size, form, and function. Comprehensive power management circuitry and software ensure the system can meet the needs of highly mobile devices that require minimal power consumption and reliable operation.

Figure 2 shows interconnect of all the major physical blocks in the CYW4373 and their associated external interfaces, which are described in greater detail in the following sections.

As shown in the Figure 2, CYW4373 provides shared BT TX and shared BT RX (sLNA) paths that enable a single antenna design while reducing the Radio Bill Of Materials (RBOM) to just an external TX/RX RF switch for 5 GHz and a diplexer in addition to commonly used passive components. For systems that require high performance with simultaneous BT and Wi-Fi operation. CYW4373 provides a dedicated BT TX/RX path that ensures more isolation with the Wi-Fi. 2.4 GHz TX/RX path and thereby enables complex coexistence schemes.

Figure 2. CYW4373 Block Diagram

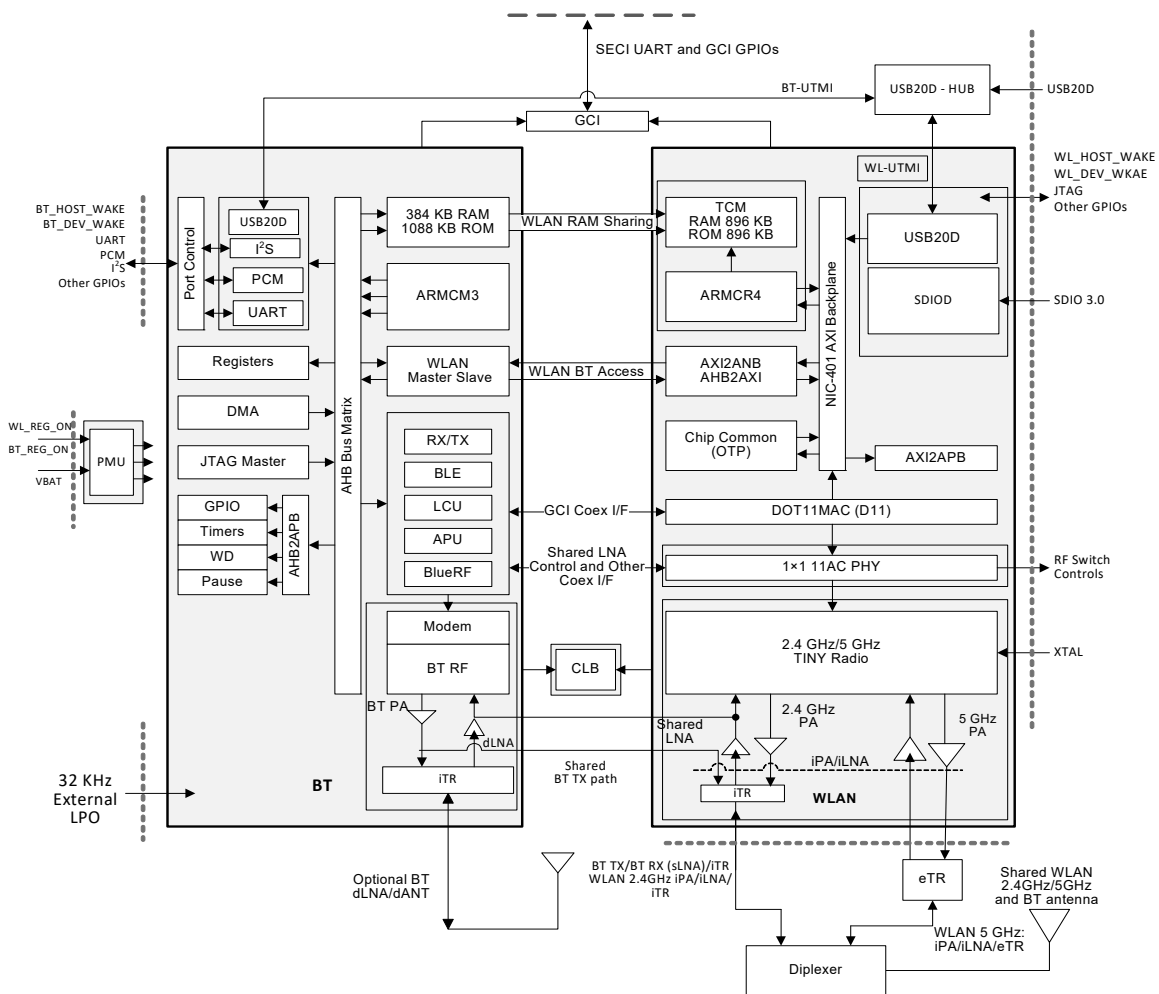

1.2 Standards Compliance

The CYW4373 supports the following standards:

- Bluetooth
 - Bluetooth 2.1 + EDR
 - Bluetooth 3.0
 - Bluetooth 4.2 Bluetooth Low Energy
 - Bluetooth 5.0
- IEEE 802.11 WLAN
 - IEEE 802.11ac Enhancements for very High Throughput for Operation in Bands below 6 GHz
 - IEEE 802.11n Enhancements for Higher Throughput
 - IEEE 802.11a High-speed Physical Layer in the 5 GHz Band
 - IEEE 802.11b Higher-Speed Physical Layer Extension in the 2.4 GHz Band
 - IEEE 802.11g further Higher Data Rate Extension in the 2.4 GHz Band
 - IEEE 802.11d Specification for operation in additional regulatory domains
 - IEEE 802.11r Fast Basic Service Set (BSS) Transition
 - IEEE 802.11w Protected Management Frames
 - IEEE 802.11e Medium Access Control (MAC) Quality of Service Enhancements
 - IEEE 802.11h Spectrum and Transmit Power Management Extensions in the 5 GHz band
 - IEEE 802.11i Medium Access Control (MAC) Security Enhancements
 - IEEE 802.11k Radio Resource Measurement of Wireless LANs
- IEEE 802.15.2 Coexistence Compliance (on-silicon solution compliant with IEEE 3-wire requirements)
- WLAN Security:
 - WEP
 - WPA-Personal
 - WPA2-Personal
 - AES (hardware accelerator)
 - TKIP (hardware accelerator)
 - CKIP (software support)
- Wi-Fi Multimedia:
 - WMM
 - Wi-Fi Multimedia - PowerSave (WMM-PS with U-APSD)
 - WMM-Sequential Access (WMM-SA with PCF)

2. Power Supplies and Power Management

2.1 Power Supply Topology

One Buck regulator, multiple LDO regulators, and a power management unit (PMU) are integrated into the CYW4373. All regulators are programmable via the PMU. These blocks simplify power supply design for Bluetooth, and WLAN functions in embedded designs.

A single V_{BAT} (3.2 V up to 4.8 V DC max.) and VIO supply (1.8 V to 3.3 V) can be used, with all additional voltages being provided by the regulators in the CYW4373.

Note: RF performance is guaranteed with V_{BAT} between the 3.6 V and 4.8 V at room temperature.

Two control signals, BT_REG_ON and WL_REG_ON, are used to power-up the regulators and take the respective section out of reset. The CBUCK CLDO and LNLDO power-up when any of the reset signals are deasserted. All regulators are powered down only when both BT_REG_ON and WL_REG_ON are deasserted. The CLDO and LNLDO may be turned off/on based on the dynamic demands of the digital baseband.

The CYW4373 allows for an extremely low power-consumption mode by completely shutting down the CBUCK, CLDO, and LNLDO regulators. When in this state, the LPLDO1 (which is the low-power linear regulator that is supplied by the system VIO supply) provides the CYW4373 with all required voltage, further reducing leakage currents.

2.2 CYW4373 PMU Features

- V_{BAT} to 1.35 V_{out} (170 mA nominal, 600 mA maximum) Core-Buck (CBUCK) switching regulator
- V_{BAT} to 3.3 V_{out} (200 mA nominal, 450 mA–850 mA maximum) LDO3P3
- V_{BAT} to 2.5 V_{out} (15 mA nominal, 70 mA maximum) BTLDO2P5
- 1.35 V to 1.2 V_{out} (50 mA nominal, 150 mA maximum) LNLDO
- 1.35 V to 1.2 V_{out} (80 mA nominal, 200 mA maximum) CLDO with bypass mode for Deep Sleep
- 1.35 V to 1.2 V_{out} (35 mA nominal, 55 mA maximum) HLDO
- Additional internal LDOs (not externally accessible)
- PMU internal timer auto-calibration by the crystal clock for precise wakeup timing from extremely low power consumption mode.

Figure 3 and Figure 4 show the regulators and a typical power topology.

Figure 4. Typical Power Topology (Page 2 of 2)

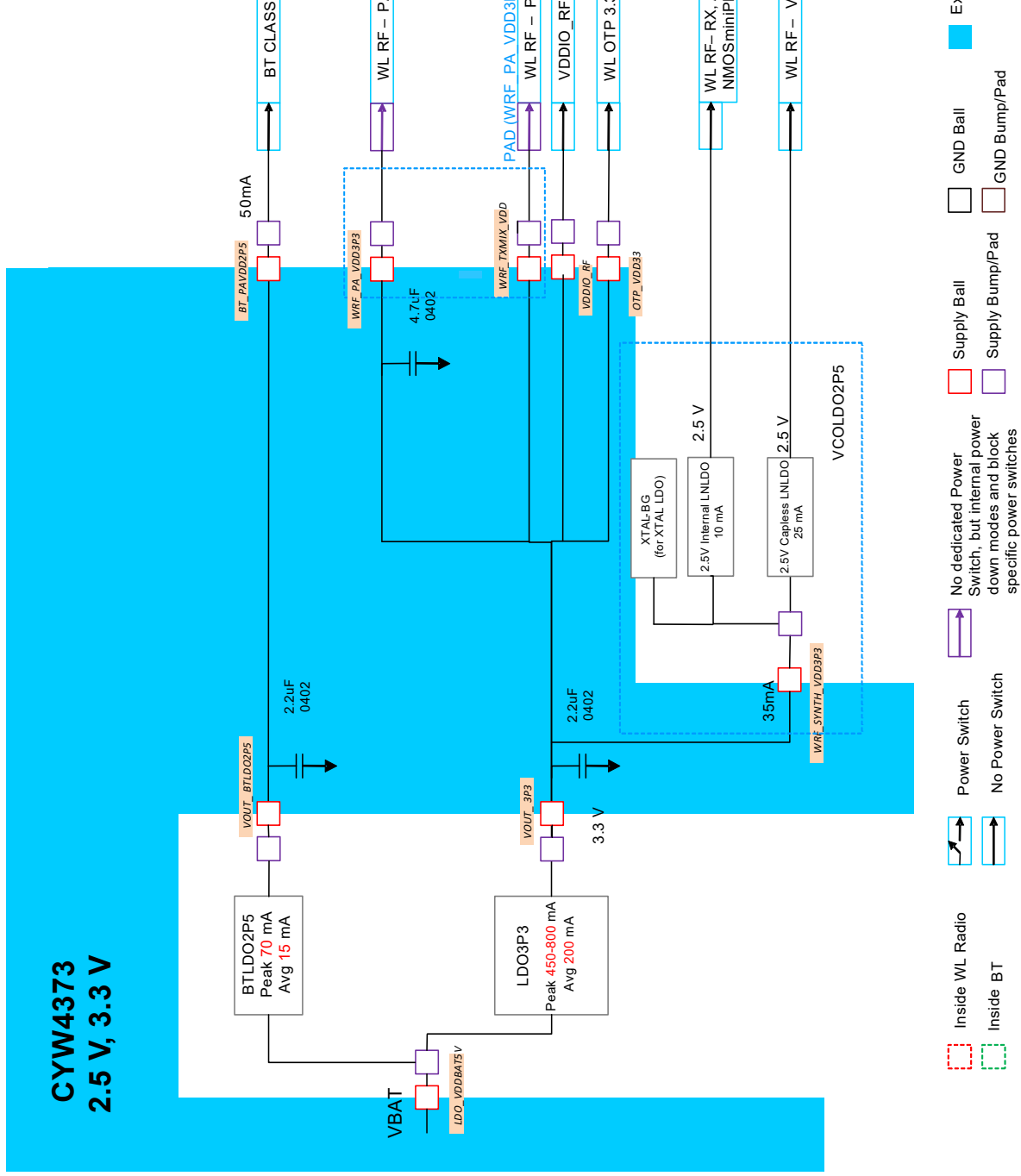

2.3 WLAN Power Management

The CYW4373 has been designed with the stringent power consumption requirements of embedded/consumer/commercial IoT devices in mind. All areas of the chip design are optimized to minimize power consumption. Silicon processes and cell libraries were chosen to reduce leakage current and supply voltages. Additionally, the CYW4373 integrated RAM is a high Vt memory with dynamic clock control. The dominant supply current consumed by the RAM is leakage current only. Additionally, the CYW4373 includes an advanced WLAN PMU sequencer. The PMU sequencer provides significant power savings by putting the CYW4373 into various power management states appropriate to the current environment and activities that are being performed. The power management unit enables and disables internal regulators, switches, and other blocks based on a computation of the required resources and a table that describes the relationship between resources and the time needed to enable and disable them. Power-up sequences are fully programmable. Configurable, free-running counters (running at 32.768 kHz LPO clock) in the PMU sequencer are used to turn on/turn off individual regulators and power switches. Clock speeds are dynamically changed (or gated altogether) for the current mode. Slower clock speeds are used wherever possible.

The CYW4373 WLAN power states are described as follows:

- **Active mode**—All WLAN blocks in the CYW4373 are powered up and fully functional with active carrier sensing and frame transmission and receiving. All required regulators are enabled and put in the most efficient mode based on the load current. Clock speeds are dynamically adjusted by the PMU sequencer.
- **Doze mode**—The radio, analog domains, and most of the linear regulators are powered down. The rest of the CYW4373 remains powered up in an IDLE state. All main clocks (PLL, crystal oscillator or TCXO) are shut down to reduce active power to the minimum. The 32.768 kHz LPO clock is available only for the PMU sequencer. This condition is necessary to allow the PMU sequencer to wake-up the chip and transition to Active mode. In Doze mode, the primary power consumed is due to leakage current.
- **Deep Sleep mode**—Most of the chip including both analog and digital domains and most of the regulators are powered off. Logic states in the digital core are saved and preserved into a retention memory in the always-ON domain before the digital core is powered off. Upon a wake-up event triggered by the PMU timers, an external interrupt or resume signaling to USB 2.0 device from USB 2.0 host, logic states in the digital core are restored to their pre-Deep Sleep settings to avoid lengthy HW reinitialization.
- **Power-down mode**—The CYW4373 is effectively powered off by shutting down all internal regulators. The chip is brought out of this mode by external logic re-enabling the internal regulators.

2.4 PMU Sequencing

The PMU sequencer is used to minimize system power consumption. It enables and disables various system resources based on a computation of required resources and a table that describes the relationship between resources and the time required to enable and disable them.

Resource requests may derive from several sources: clock requests from cores, the minimum resources defined in the *ResourceMin* register, and the resources requested by any active resource request timers. The PMU sequencer maps clock requests into a set of resources required to produce the requested clocks.

Each resource is in one of four states:

- Enabled
- Disabled
- Transition_on
- Transition_off

The timer contains 0 when the resource is enabled or disabled and a non-zero value in the transition states. The timer is loaded with the *time_on* or *time_off* value of the resource when the PMU determines that the resource must be enabled or disabled. That timer decrements on each 32.768 kHz PMU clock. When it reaches 0, the state changes from *transition_off* to disabled or *transition_on* to enabled. If the *time_on* value is 0, the resource can transition immediately from disabled to enabled. Similarly, a *time_off* value of 0 indicates that the resource can transition immediately from enabled to disabled. The terms *enable sequence* and *disable sequence* refer to either the immediate transition or the timer load-decrement sequence.

During each clock cycle, the PMU sequencer performs the following actions:

- Computes the required resource set based on requests and the resource dependency table
- Decrements all timers whose values are non zero. If a timer reaches 0, the PMU clears the ResourcePending bit for the resource and inverts the ResourceState bit
- Compares the request with the current resource status and determines which resources must be enabled or disabled
- Initiates a disable sequence for each resource that is enabled, no longer being requested, and has no powered up dependents
- Initiates an enable sequence for each resource that is disabled, is being requested, and has all of its dependencies enabled

2.5 Power-Off Shutdown

The CYW4373 provides a low-power shutdown feature that allows the device to be turned OFF while the host, and any other devices in the system, remain operational. When the CYW4373 is not needed in the system, VDDIO_RF and VDDC are shut down while VDDIO remains powered. This allows the CYW4373 to be effectively off while keeping the I/O pins powered so that they do not draw extra current from any other devices connected to the I/O.

During a low-power shutdown state, provided VDDIO remains applied to the CYW4373, all outputs are in tristate, and most inputs signals are disabled. Input voltages must remain within the limits defined for normal operation. This is done to prevent current paths or create loading on any digital signals in the system, and enables the CYW4373 to be fully integrated in an embedded device and take full advantage of the lowest power-savings modes.

When the CYW4373 is powered on from this state, it is the same as a normal power-up and the device does not retain any information about its state from before it was powered down.

2.6 Power-Up/Power-Down/Reset Circuits

The CYW4373 has two signals (see [Table 1](#)) that enable or disable the Bluetooth and WLAN circuits and the internal regulator blocks, allowing the host to control power consumption. For timing diagrams of these signals and the required power-up sequences, see [Section 20. "Power-Up Sequence and Timing"](#).

Table 1. Power-Up/Power-Down/Reset Control Signals

Signal	Description
WL_REG_ON	This signal is used by the PMU (with BT_REG_ON) to power-up the WLAN section. It is also OR-gated with the BT_REG_ON input to control the internal CYW4373 regulators. When this pin is high, the regulators are enabled and the WLAN section is out of reset. When this pin is low, the WLAN section is in reset. If BT_REG_ON and WL_REG_ON are both LOW, the regulators are disabled. This pin has an internal 200 kΩ pull-down resistor that is enabled by default. It can be disabled through programming.
BT_REG_ON	This signal is used by the PMU (with WL_REG_ON) to decide whether or not to power down the internal CYW4373 regulators. If BT_REG_ON and WL_REG_ON are LOW, the regulators will be disabled. This pin has an internal 200 kΩ pull-down resistor that is enabled by default. It can be disabled through programming.

3. Frequency References

An external crystal is used for generating all radio frequencies and normal operation clocking. As an alternative, an external frequency reference may be used. In addition, a low-power oscillator (LPO) is provided for lower power mode timing.

3.1 Crystal Interface and Clock Generation

The CYW4373 can use an external crystal to provide a frequency reference. The recommended configuration for the crystal oscillator including all external components is shown in [Figure 5](#). Consult the reference schematics for the latest configuration.

Figure 5. Recommended Oscillator Configuration

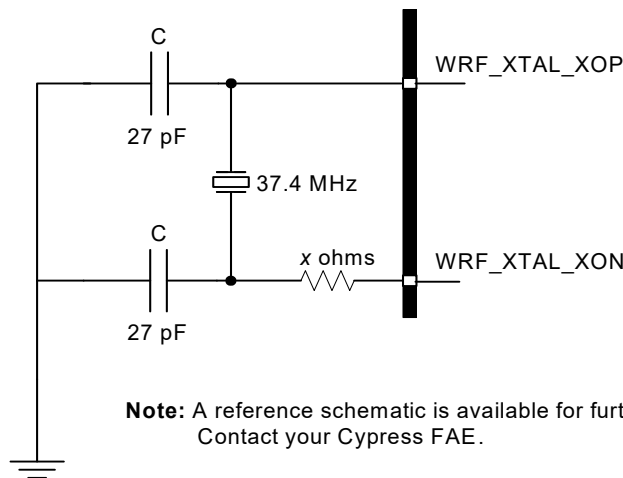

A fractional-N synthesizer in the CYW4373 generates the radio frequencies, clocks, and data/packet timing, enabling it to operate using a wide selection of frequency references.

The recommended default frequency reference is a 37.4 MHz crystal. The signal characteristics for the crystal interface are listed in [Table 2](#).

Note: Although the fractional-N synthesizer can support alternative reference frequencies, frequencies other than the default require support to be added in the driver, plus additional extensive system testing. Contact Cypress for further details.

3.2 External Frequency Reference

As an alternative to a crystal, an external precision frequency reference can be used, provided that it meets the Phase Noise requirements listed in [Table 2](#).

If used, the external clock should be connected to the WRF_XTAL_XOP pin through an external 1000 pF coupling capacitor, as shown in [Figure 6](#). The internal clock buffer connected to this pin will be turned OFF when the CYW4373 goes into sleep mode. When the clock buffer turns ON and OFF there will be a small impedance variation. Power must be supplied to the WRF_XTAL_VDD1P35 pin.

Figure 6. Recommended Circuit to Use With an External Reference Clock

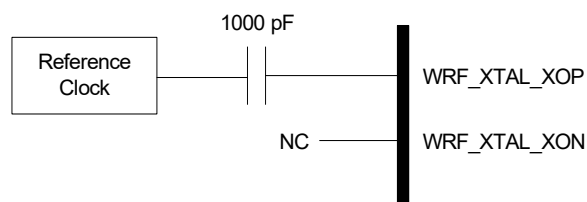

Table 2. Crystal Oscillator and External Clock—Requirements and Performance

Parameter	Conditions/Notes	Crystal ¹			External Frequency Reference ²			Unit
		Min	Typ	Max	Min	Typ	Max	
Frequency	SDIO 3.0, and USB 2.0 WLAN interfaces	–	37.4	–	–	37.4	–	MHz
Frequency tolerance over the lifetime of the equipment, including temperature ³	Without trimming	–20	–	20	–20	–	20	ppm
Crystal load capacitance	–	–	16	–	–	–	–	pF
ESR	–	–	–	60	–	–	–	Ω
Drive level	External crystal must be able to tolerate this drive level.	200	–	–	–	–	–	μW
Input impedance (WRF_XTAL_XOP)	Resistive	–	–	–	30k	100k	–	Ω
	Capacitive	–	–	7.5	–	–	7.5	pF
WRF_XTAL_XOP Input low level	DC-coupled digital signal	–	–	–	0	–	0.2	V
WRF_XTAL_XOP Input high level	DC-coupled digital signal	–	–	–	1.0	–	1.26	V
WRF_XTAL_XOP input voltage(see Figure 6)	IEEE 802.11a/b/g operation only	–	–	–	400	–	1200	mV _{p-p}
WRF_XTAL_XOP input voltage(see Figure 6)	IEEE 802.11n/ac AC-coupled analog input	–	–	–	1	–	–	V _{p-p}
Duty cycle	37.4 MHz clock	–	–	–	40	50	60	%
Phase Noise ⁴ (IEEE 802.11b/g)	37.4 MHz clock at 10 kHz offset	–	–	–	–	–	–129	dBc/Hz
	37.4 MHz clock at 100 kHz offset	–	–	–	–	–	–136	dBc/Hz
Phase Noise ⁴ (IEEE 802.11a)	37.4 MHz clock at 10 kHz offset	–	–	–	–	–	–137	dBc/Hz
	37.4 MHz clock at 100 kHz offset	–	–	–	–	–	–144	dBc/Hz
Phase Noise ⁴ (IEEE 802.11n, 2.4 GHz)	37.4 MHz clock at 10 kHz offset	–	–	–	–	–	–134	dBc/Hz
	37.4 MHz clock at 100 kHz offset	–	–	–	–	–	–141	dBc/Hz
Phase Noise ⁴ (IEEE 802.11n, 5 GHz)	37.4 MHz clock at 10 kHz offset	–	–	–	–	–	–142	dBc/Hz
	37.4 MHz clock at 100 kHz offset	–	–	–	–	–	–149	dBc/Hz
Phase Noise ⁴ (IEEE 802.11ac, 5 GHz)	37.4 MHz clock at 10 kHz offset	–	–	–	–	–	–148	dBc/Hz
	37.4 MHz clock at 100 kHz offset	–	–	–	–	–	–155	dBc/Hz

1. (Crystal) Use WRF_XTAL_XON and WRF_XTAL_XOP.
2. See "External Frequency Reference" for alternative connection methods.
3. It is the responsibility of the equipment designer to select oscillator components that comply with these specifications.
4. Assumes that external clock has a flat phase noise response above 100 kHz.

3.3 External 32.768 kHz Low-Power Oscillator

The CYW4373 uses a secondary low frequency clock for low-power-mode timing. Either the internal low-precision LPO or an external 32.768 kHz precision oscillator is required. The internal LPO frequency range is approximately 33 kHz \pm 30% over process, voltage, and temperature, which is adequate for some applications. However, one trade-off caused by this wide LPO tolerance is a small current consumption increase during power save mode that is incurred by the need to wake-up earlier to avoid missing beacons.

Whenever possible, the preferred approach is to use a precision external 32.768 kHz clock that meets the requirements listed in [Table 3](#).

Table 3. External 32.768 kHz Sleep Clock Specifications

Parameter	LPO Clock	Unit
Nominal input frequency	32.768	kHz
Frequency accuracy	± 200	ppm
Duty cycle	30–70	%
Input signal amplitude	200–3300	mV, p-p
Signal type	Square-wave or sine-wave	–
Input impedance ¹	>100k <5	Ω pF
Clock jitter (during initial start-up)	<10,000	ppm

1. When power is applied or switched off.

4. Bluetooth Overview

The CYW4373 is a Bluetooth 5.0 compliant, baseband processor with 2.4 GHz transceiver. It features the highest level of integration and eliminates all critical external components, thus minimizing the footprint, power consumption, and system cost of a Bluetooth radio solution.

The CYW4373 is the optimal solution for any Bluetooth voice and/or data application. The Bluetooth subsystem presents a standard host controller interface (HCI) via a high-speed UART or shared USB 2.0 and I²S/PCM for audio. The CYW4373 incorporates all Bluetooth 4.2 features including secure simple pairing, sniff subrating, and encryption pause and resume.

The CYW4373 Bluetooth radio transceiver provides enhanced radio performance to meet the most stringent temperature applications and the tightest integration into IoT and embedded applications. It provides full radio compatibility to operate simultaneously with GPS, WLAN, and cellular radios.

The Bluetooth transmitter also features a Class 1 power amplifier with Class 2 capability.

4.1 Features

Primary CYW4373 Bluetooth features include:

- Bluetooth 5.0 qualified with all errata (applicable to v4.2 and earlier) fixed as well as all support for all optional Bluetooth 4.2 features
- Fully supports Bluetooth Core Specification version 5.0 + EDR features:
 - Adaptive frequency hopping (AFH)
 - Quality of service (QoS)
 - Extended synchronous connections (eSCO)—voice connections
 - Fast connect (interlaced page and inquiry scans)
 - Secure simple pairing (SSP)
 - Sniff subrating (SSR)
 - Encryption pause resume (EPR)
 - Extended inquiry response (EIR)
 - Link supervision timeout (LST)
- USB wake up from L2 deep sleep state through LINESTATE of HUB
- UART baud rates up to 4 Mbps
- Host interface with USB 1.1 with Full Speed data rate
- Host Interface with Shared USB 2.0 with High Speed data rate
- Supports all Bluetooth 5.0 + HS packet types
- Supports maximum Bluetooth data rates over HCI UART
- USB 2.0 hub for a shared single USB connection to both Bluetooth and WLAN
- Multipoint operation with up to seven active slaves
 - Maximum of seven simultaneous active ACL links
 - Maximum of three simultaneous active SCO and eSCO connections with scatternet support
- Trigger Cypress fast connect (TCFC)
- Narrow band and wide band packet loss concealment
- Scatternet operation with up to four active piconets with background scan and support for scatter mode
- High-speed HCI UART transport support with low-power out-of-band BT_DEV_WAKE and BT_HOST_WAKE signaling (see [“Host Controller Power Management”](#))
- Channel quality driven data rate and packet type selection
- Standard Bluetooth test modes
- Extended radio and production test mode features

- Full support for power savings modes
 - Bluetooth clock request
 - Bluetooth standard sniff
 - Deep-sleep modes and software regulator shutdown
- Supports a low-power crystal, which can be used during power save mode for better timing accuracy.

4.2 Bluetooth Radio

The CYW4373 has an integrated radio transceiver that has been optimized for use in 2.4 GHz Bluetooth wireless systems. It has been designed to provide low-power, low-cost, robust communications for applications operating in the globally available 2.4 GHz unlicensed ISM band. It is fully compliant with the Bluetooth Radio Specification, EDR specification and Bluetooth Low Energy specification and exceeds the requirements to provide the highest communication link quality of service.

4.2.1 Transmit

The CYW4373 features a fully integrated zero-IF transmitter. The baseband transmit data is GFSK-modulated in the modem block and upconverted to the 2.4 GHz ISM band in the transmitter path. The transmitter path consists of signal filtering, I/Q upconversion, output power amplifier, and RF filtering. The transmitter path also incorporates $\pi/4$ -DQPSK for 2 Mbps and 8-DPSK for 3 Mbps to support EDR. The transmitter section is compatible to the Bluetooth Low Energy specification. The transmitter PA bias can also be adjusted to provide Bluetooth class 1 or class 2 operation.

4.2.2 Digital Modulator

The digital modulator performs the data modulation and filtering required for the GFSK, $\pi/4$ -DQPSK, and 8-DPSK signal. The fully digital modulator minimizes any frequency drift or anomalies in the modulation characteristics of the transmitted signal and is much more stable than direct VCO modulation schemes.

4.2.3 Digital Demodulator and Bit Synchronizer

The digital demodulator and bit synchronizer take the low-IF received signal and perform an optimal frequency tracking and bit-synchronization algorithm.

4.2.4 Power Amplifier

The fully integrated PA supports Class 1 or Class 2 output using a highly linearized, temperature-compensated design. This provides greater flexibility in front-end matching and filtering. Due to the linear nature of the PA combined with some integrated filtering, external filtering is required to meet the Bluetooth and regulatory harmonic and spurious requirements. For IoT and embedded applications in which Bluetooth is next to the other radios, external filtering can be applied to achieve near thermal noise levels for spurious and radiated noise emissions. The transmitter features a sophisticated on-chip transmit signal strength indicator (TSSI) block to keep the absolute output power variation within a tight range across process, voltage, and temperature.

4.2.5 Receiver

The receiver path uses a low-IF scheme to downconvert the received signal for demodulation in the digital demodulator and bit synchronizer. The receiver path provides a high degree of linearity, an extended dynamic range, and high-order on-chip channel filtering to ensure reliable operation in the noisy 2.4 GHz ISM band. The front-end topology with built-in out-of-band attenuation enables the CYW4373 to be used in most applications with minimal off-chip filtering. For IoT and embedded applications, in which the Bluetooth function is integrated close to the other radio transmitters, external filtering is required to eliminate the desensitization of the receiver.

4.2.6 Digital Demodulator and Bit Synchronizer

The digital demodulator and bit synchronizer take the low-IF received signal and perform an optimal frequency tracking and bit synchronization algorithm.

4.2.7 Receiver Signal Strength Indicator

The radio portion of the CYW4373 provides a receiver signal strength indicator (RSSI) signal to the baseband, so that the controller can take part in a Bluetooth power-controlled link by providing a metric of its own receiver signal strength to determine whether the transmitter should increase or decrease its output power.

4.2.8 Local Oscillator (LO) Generation

LO generation provides fast frequency hopping (1600 hops/second) across the 79 maximum available channels. The LO generation subblock employs an architecture for high immunity to LO pulling during PA operation. The CYW4373 uses an internal RF and IF loop filter.

4.2.9 Calibration

The CYW4373 radio transceiver features an automated calibration scheme that is fully self contained in the radio. No user interaction is required during normal operation or during manufacturing to provide the optimal performance. Calibration optimizes the performance of all the major blocks within the radio to within 2% of optimal conditions, including gain and phase characteristics of filters, matching between key components, and key gain blocks. This takes into account process variation and temperature variation. Calibration occurs transparently during normal operation during the settling time of the hops and calibrates for temperature variations as the device cools and heats during normal operation in its environment.

5. Bluetooth Baseband Core (BBC)

The BBC implements all of the time critical functions required for high-performance Bluetooth operation. The BBC manages the buffering, segmentation, and routing of data for all connections. It also buffers data that passes through it, handles data flow control, schedules SCO/ACL TX/RX transactions, monitors Bluetooth slot usage, optimally segments and packages data into baseband packets, manages connection status indicators, and composes and decodes HCI packets. In addition to these functions, it independently handles HCI event types, and HCI command types.

The following transmit and receive functions are also implemented in the BBC hardware to increase reliability and security of the TX/RX data before sending over the air:

- Symbol timing recovery, data deframing, forward error correction (FEC), header error control (HEC), cyclic redundancy check (CRC), data decryption, and data dewatering in the receiver.
- Data framing, FEC generation, HEC generation, CRC generation, key generation, data encryption, and data whitening in the transmitter.

5.1 Bluetooth 5.0 Features

CYW4373 is Bluetooth 5.0 qualified with all errata applicable to v4.2 and earlier core specifications fixed. These fixes ensure compliance to the Bluetooth 5.0 specification. For a complete list of errata visit <https://www.bluetooth.com/specifications/errata>.

5.2 Bluetooth 4.0 Features

The BBC supports all Bluetooth 4.0 features, with the following benefits:

- Dual-mode Bluetooth Low Energy (BT and BLE operation)
- Extended Inquiry Response (EIR): Shortens the time to retrieve the device name, specific profile, and operating mode.
- Encryption Pause Resume (EPR): Enables the use of Bluetooth technology in a much more secure environment.
- Sniff Subrating (SSR): Optimizes power consumption for low duty cycle asymmetric data flow, which subsequently extends battery life.
- Secure Simple Pairing (SSP): Reduces the number of steps for connecting two devices, with minimal or no user interaction required.
- Link Supervision Time Out (LSTO): Additional commands added to HCI and Link Management Protocol (LMP) for improved link time-out supervision.
- QoS enhancements: Changes to data traffic control, which results in better link performance. Audio, human interface device (HID), bulk traffic, SCO, and enhanced SCO (eSCO) are improved with the erroneous data (ED) and packet boundary flag (PBF) enhancements.

5.3 Bluetooth 5.0 Features

The BBC supports all Bluetooth 5.0 features, with the following benefits:

- LE Secure Connections to enable secure connection establishment using the Elliptic-Curve Diffie-Hellman algorithm
- LE Privacy 1.2 to enable low-power private address resolution
- LE Data Length Extension to support longer Bluetooth Low Energy packets

Note: The CYW4373 is compatible with the Bluetooth Low Energy operating mode, which provides a dramatic reduction in the power consumption of the Bluetooth radio and baseband. The primary application for this mode is to provide support for low data rate devices, such as sensors and remote controls.

5.4 Bluetooth Low Energy

The CYW4373 supports the Bluetooth Low Energy operating mode.

5.5 Link Control Layer (LCU)

The link control layer is part of the Bluetooth link control functions that are implemented in dedicated logic in the LCU. This layer consists of the command controller that takes commands from the software, and other controllers that are activated or configured by the command controller, to perform the link control tasks. Each task performs a different state in the Bluetooth Link Controller.

- Major states:
 - Standby
 - Connection
- Substates:
 - Page
 - Page Scan
 - Inquiry
 - Inquiry Scan
 - Sniff

5.6 Test Mode Support

The CYW4373 fully supports Bluetooth Test mode. This includes the transmitter tests, normal and delayed loopback tests, and reduced hopping sequence.

In addition to the standard Bluetooth Test Mode, the CYW4373 also supports enhanced testing features to simplify RF debugging and qualification and type-approval testing. These features include:

- Fixed frequency carrier wave (unmodulated) transmission
 - Simplifies some type-approval measurements (Japan)
 - Aids in transmitter performance analysis
- Fixed frequency constant receiver mode
 - Receiver output directed to I/O pin
 - Allows for direct BER measurements using standard RF test equipment
 - Facilitates spurious emissions testing for receive mode
- Fixed frequency constant transmission
 - 8-bit fixed pattern or PRBS-9
 - Enables modulated signal measurements with standard RF test equipment

5.7 Bluetooth Power Management Unit

The Bluetooth Power Management Unit (PMU) provides power management features that can be invoked by either software through power management registers or packet handling in the baseband core.

The power management functions provided by the CYW4373 are:

- RF Power Management
- Host Controller Power Management
- BBC Power Management

5.7.1 RF Power Management

The BBC generates power-down control signals for the transmit path, receive path, PLL, and power amplifier to the 2.4 GHz transceiver. The transceiver then processes the power-down functions accordingly.

5.7.2 Host Controller Power Management

When running in UART mode, the CYW4373 may be configured so that dedicated signals are used for power management hand-shaking between the CYW4373 and the host. The basic power saving functions supported by those hand-shaking signals include the standard Bluetooth defined power savings modes and standby modes of operation. Table 4 describes the power-control handshake signals used with the UART interface.

When in USB 2.0 mode, L2 suspend is supported to enable Power saving.

Note: Pad function Control Register is set to 0 for these pins. See “DC Characteristics” for more details.

Table 4. Power Control Pin Description

Signal	Mapped to Pin	Type	Description
BT_DEV_WAKE	BT_GPIO_0	I	Bluetooth device wakeup: Signal from the host to the CYW4373 indicating that the host requires attention. <ul style="list-style-type: none"> ■ Asserted: The Bluetooth device must wakeup or remain awake. ■ Deasserted: The Bluetooth device may sleep when sleep criteria are met. The polarity of this signal is software configurable and can be asserted high or low.
BT_HOST_WAKE	BT_GPIO_1	O	Host wakeup. Signal from the CYW4373 to the host indicating that the CYW4373 requires attention. <ul style="list-style-type: none"> ■ Asserted: host device must wake-up or remain awake. ■ Deasserted: host device may sleep when sleep criteria are met. The polarity of this signal is software configurable and can be asserted high or low.
CLK_REQ	BT_CLK_REQ_OUT WL_CLK_REQ_OUT	O	The CYW4373 asserts CLK_REQ when Bluetooth or WLAN wants the host to turn on the reference clock. The CLK_REQ polarity is active-high. Add an external 100 kΩ pull-down resistor to ensure the signal is deasserted when the CYW4373 powers up or resets when VDDIO is present.

Figure 7 shows the startup signaling sequence prior to software download.

Figure 7. Startup Signaling Sequence Prior to Software Download

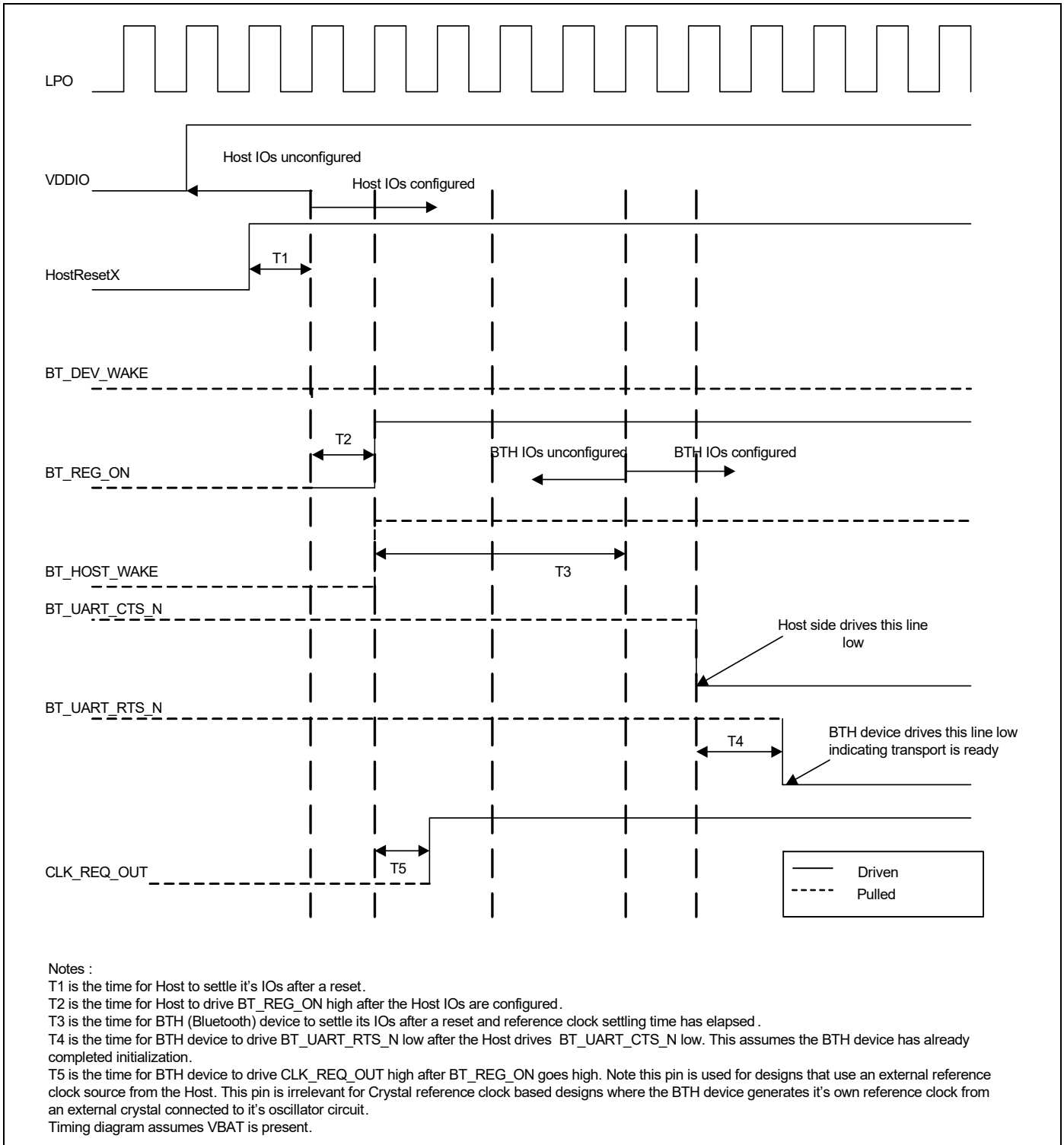

5.7.3 BBC Power Management

The following are low-power operations for the BBC:

- Physical layer packet-handling turns the RF on and off dynamically within transmit/receive packets.
- Bluetooth-specified low-power connection modes: sniff, hold, and park. While in these modes, the CYW4373 runs on the low-power oscillator and wakes up after a predefined time period.
- A low-power shutdown feature allows the device to be turned off while the host and any other devices in the system remain operational. When the CYW4373 is not needed in the system, the RF and core supplies are shut down while the I/O remains powered. This allows the CYW4373 to effectively be OFF while keeping the I/O pins powered so they do not draw extra current from any other devices connected to the I/O.

During the low-power shutdown state, provided VDDIO remains applied to the CYW4373, all outputs are in tristate, and most input signals are disabled. Input voltages must remain within the limits defined for normal operation. This is done to prevent current paths or create loading on any digital signals in the system and enables the CYW4373 to be fully integrated in an embedded device to take full advantage of the lowest power-saving modes.

Two CYW4373 input signals are designed to be high-impedance inputs that do not load the driving signal even if the chip does not have VDDIO power supplied to it: the frequency reference input (WRF_TCXO_IN) and the 32.768 kHz input (LPO). When the CYW4373 is powered on from this state, it is the same as a normal power-up, and the device does not contain any information about its state from the time before it was powered down.

Wideband Speech (WBS)

The CYW4373 provides support for WBS using on-chip Cypress SmartAudio® technology. The CYW4373 can perform subband-codec (SBC), as well as mSBC, encoding and decoding of linear 16 bits at 16 kHz (256 Kbps rate) transferred over the PCM bus.

Packet Loss Concealment (PLC)

Packet Loss Concealment (PLC) improves apparent audio quality for systems with marginal link performance. Bluetooth messages are sent in packets. When a packet is lost, it creates a gap in the received audio bit-stream. Packet loss can be mitigated in several ways:

- Fill in zeros.
- Ramp down the output audio signal toward zero (this is the method used in current Bluetooth headsets).
- Repeat the last frame (or packet) of the received bit-stream and decode it as usual (frame repeat).

These techniques cause distortion and popping in the audio stream. The CYW4373 uses a proprietary waveform extension algorithm to provide dramatic improvement in the audio quality. [Figure 8](#) and [Figure 9](#) show audio waveforms with and without PLC. Cypress PLC/BEC algorithms also support wideband speech.

Figure 8. CVSD Decoder Output Waveform Without PLC

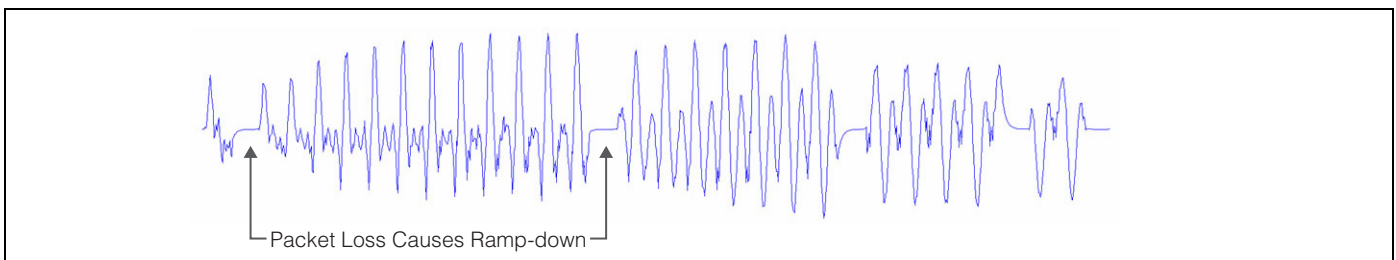
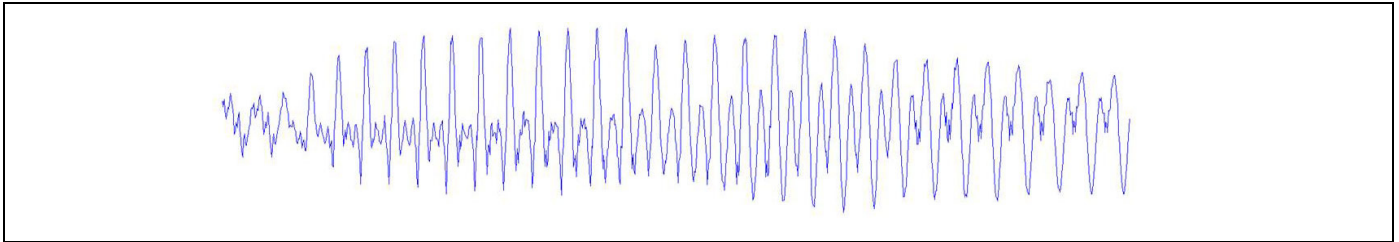

Figure 9. CVSD Decoder Output Waveform After Applying PLC**Audio Rate-Matching Algorithms**

The CYW4373 has an enhanced rate-matching algorithm that uses interpolation algorithms to reduce audio stream jitter that may be present when the rate of audio data coming from the host is not the same as the Bluetooth audio data rates.

Codec Encoding

The CYW4373 can support SBC and mSBC encoding and decoding for WBS.

Multiple Simultaneous A2DP Audio Stream

The CYW4373 has the ability to take a single audio stream and output it to multiple Bluetooth devices simultaneously. This allows a user to share his or her music (or any audio stream) with a friend.

Burst Buffer Operation

The CYW4373 has a data buffer that can buffer data being sent over the HCI and audio transports, then send the data at an increased rate. This mode of operation allows the host to sleep for the maximum amount of time, dramatically reducing system current consumption.

5.8 Adaptive Frequency Hopping

The CYW4373 gathers link quality statistics on a channel by channel basis to facilitate channel assessment and channel map selection. The link quality is determined using both RF and baseband signal processing to provide a more accurate frequency-hop map.

5.9 Advanced Bluetooth/WLAN Coexistence

The CYW4373 includes advanced coexistence technologies that are only possible with a Bluetooth/WLAN integrated die solution. These coexistence technologies are targeted at small form-factor platforms, such as cell phones and media players, including applications such as VoWLAN + SCO and Video-over-WLAN + High Fidelity BT Stereo.

Support is provided for platforms that share a single antenna between Bluetooth and WLAN. Dual-antenna applications are also supported. The CYW4373 radio architecture allows for lossless simultaneous Bluetooth and WLAN reception for shared antenna applications. This is possible only via an integrated solution (shared LNA and joint AGC algorithm). It has superior performance versus implementations that need to arbitrate between Bluetooth and WLAN reception.

The CYW4373 integrated solution enables MAC-layer signaling (firmware) and a greater degree of sharing via an enhanced coexistence interface. Information is exchanged between the Bluetooth and WLAN cores without host processor involvement.

The CYW4373 also supports Transmit Power Control on the STA together with standard Bluetooth TPC to limit mutual interference and receiver desensitization. Preemption mechanisms are utilized to prevent AP transmissions from colliding with Bluetooth frames. Improved channel classification techniques have been implemented in Bluetooth for faster and more accurate detection and elimination of interferers (including non-WLAN 2.4 GHz interference).

The Bluetooth AFH classification is also enhanced by the WLAN core's channel information.

5.10 Fast Connection (Interlaced Page and Inquiry Scans)

The CYW4373 supports page scan and inquiry scan modes that significantly reduce the average inquiry response and connection times. These scanning modes are compatible with the Bluetooth v2.1 page and inquiry procedures.

6. Microprocessor and Memory Unit for Bluetooth

The Bluetooth microprocessor core is based on the ARM Cortex-M3 32-bit RISC processor with embedded ICE-RT debug and JTAG interface units. It runs software from the link control (LC) layer, up to the HCI.

The ARM core is paired with a memory unit that contains 1088 KB of ROM memory for program storage and boot ROM, 384 KB of RAM for data scratchpad and patch RAM code. The internal ROM allows for flexibility during power-on reset to enable the same device to be used in various configurations. At power-up, the lower-layer protocol stack is executed from the internal ROM memory.

External patches may be applied to the ROM-based firmware to provide flexibility for bug fixes or features additions. These patches may be downloaded from the host to the CYW4373 through the UART transports or shared USB 2.0 interface. The mechanism for downloading via UART is identical to the proven interface of the CYW4329 and CYW4330 devices.

6.1 RAM, ROM, and Patch Memory

The CYW4373 Bluetooth core has 384 KB of internal RAM which is mapped between general purpose scratch pad memory and patch memory and 1088 KB of ROM used for the lower-layer protocol stack, test mode software, and boot ROM. The patch memory capability enables the addition of code changes for purposes of feature additions and bug fixes to the ROM memory.

6.2 Reset

The CYW4373 has an integrated power-on reset circuit that resets all circuits to a known power-on state. The BT power-on reset (POR) circuit is out of reset after BT_REG_ON goes High. If BT_REG_ON is LOW, then the POR circuit is held in reset.

7. Bluetooth Peripheral Transport Unit

7.1 PCM Interface

The CYW4373 has an independent PCM interface. The PCM Interface on the CYW4373 can connect to linear PCM Codec devices in master or slave mode. In master mode, the CYW4373 generates the PCM_CLK and PCM_SYNC signals, and in slave mode, these signals are provided by another master on the PCM interface and are inputs to the CYW4373.

The configuration of the PCM interface may be adjusted by the host through the use of vendor-specific HCI commands.

7.1.1 Slot Mapping

The CYW4373 supports up to three simultaneous full-duplex SCO or eSCO channels through the PCM interface. These three channels are time-multiplexed onto the single PCM interface by using a time-slotting scheme where the 8 kHz or 16 kHz audio sample interval is divided into as many as 16 slots. The number of slots is dependent on the selected interface rate of 128 kHz, 512 kHz, or 1024 kHz. The corresponding number of slots for these interface rate is 1, 2, 4, 8, and 16, respectively. Transmit and receive PCM data from an SCO channel is always mapped to the same slot. The PCM data output driver tristates its output on unused slots to allow other devices to share the same PCM interface signals. The data output driver tristates its output after the falling edge of the PCM clock during the last bit of the slot.

7.1.2 Frame Synchronization

The CYW4373 supports both short- and long-frame synchronization in both master and slave modes. In short-frame synchronization mode, the frame synchronization signal is an active-high pulse at the audio frame rate that is a single-bit period in width and is synchronized to the rising edge of the bit clock. The PCM slave looks for a high on the falling edge of the bit clock and expects the first bit of the first slot to start at the next rising edge of the clock. In long-frame synchronization mode, the frame synchronization signal is again an active-high pulse at the audio frame rate; however, the duration is three bit periods and the pulse starts coincident with the first bit of the first slot.

7.1.3 Data Formatting

The CYW4373 may be configured to generate and accept several different data formats. For conventional narrowband speech mode, the CYW4373 uses 13 of the 16 bits in each PCM frame. The location and order of these 13 bits can be configured to support various data formats on the PCM interface. The remaining three bits are ignored on the input and may be filled with 0s, 1s, a sign bit, or a programmed value on the output. The default format is 13-bit 2's complement data, left justified, and clocked MSB first.

7.1.4 Wideband Speech Support

When the host encodes Wideband Speech (WBS) packets in transparent mode, the encoded packets are transferred over the PCM bus for an eSCO voice connection. In this mode, the PCM bus is typically configured in master mode for a 4 kHz sync rate with 16-bit samples, resulting in a 64 Kbps bit rate. The CYW4373 also supports slave transparent mode using a proprietary rate-matching scheme. In SBC-code mode, linear 16-bit data at 16 kHz (256 Kbps rate) is transferred over the PCM bus.

7.1.5 Multiplexed Bluetooth Over PCM

Bluetooth supports multiple audio streams within the Bluetooth channel and both 16 kHz and 8 kHz streams can be multiplexed. This mode of operation is only supported when the Bluetooth host is the master. Figure 10 shows the operation of the multiplexed transport with three simultaneous SCO connections. To accommodate additional SCO channels, the transport clock speed is increased. To change between modes of operation, the transport must be halted and restarted in the new configuration.

Figure 10. Functional Multiplex Data Diagram

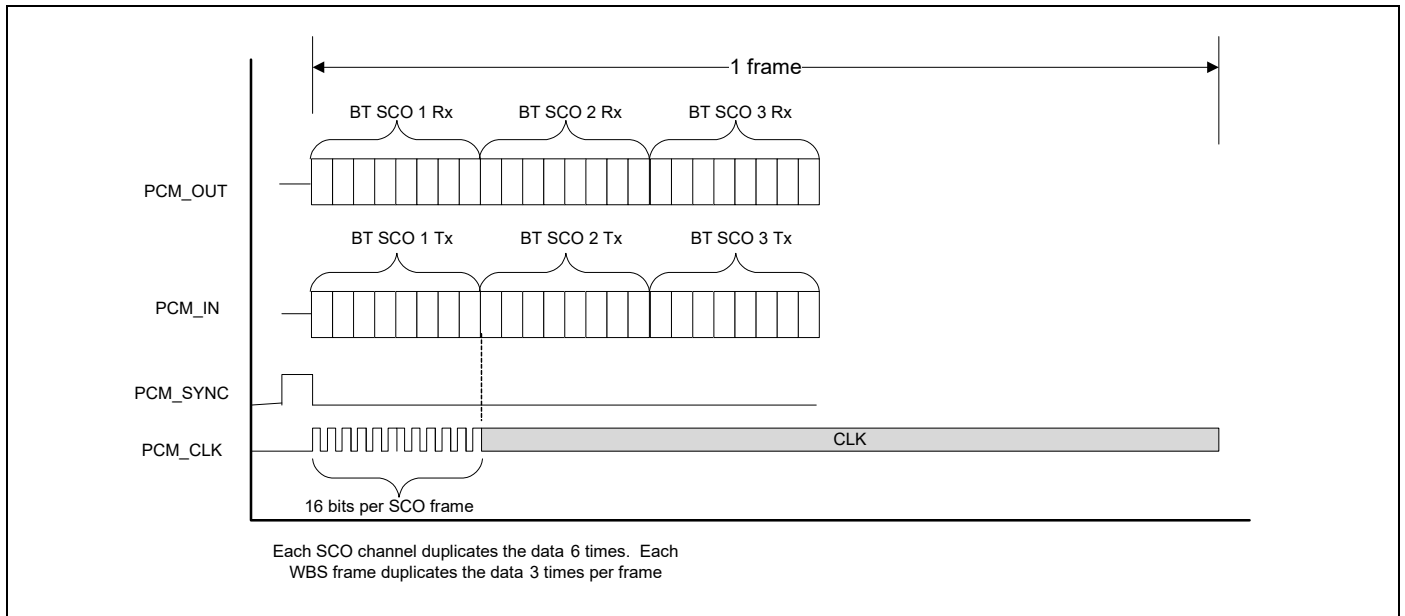

7.1.6 Burst PCM Mode

In this mode of operation, the PCM bus runs at a significantly higher rate of operation to allow the host to duty cycle its operation and save current. In this mode of operation, the PCM bus can operate at a rate of up to 24 MHz. This mode of operation is initiated with an HCI command from the host.

7.1.7 PCM Interface Timing

Short Frame Sync, Master Mode

Figure 11. PCM Timing Diagram (Short Frame Sync, Master Mode)

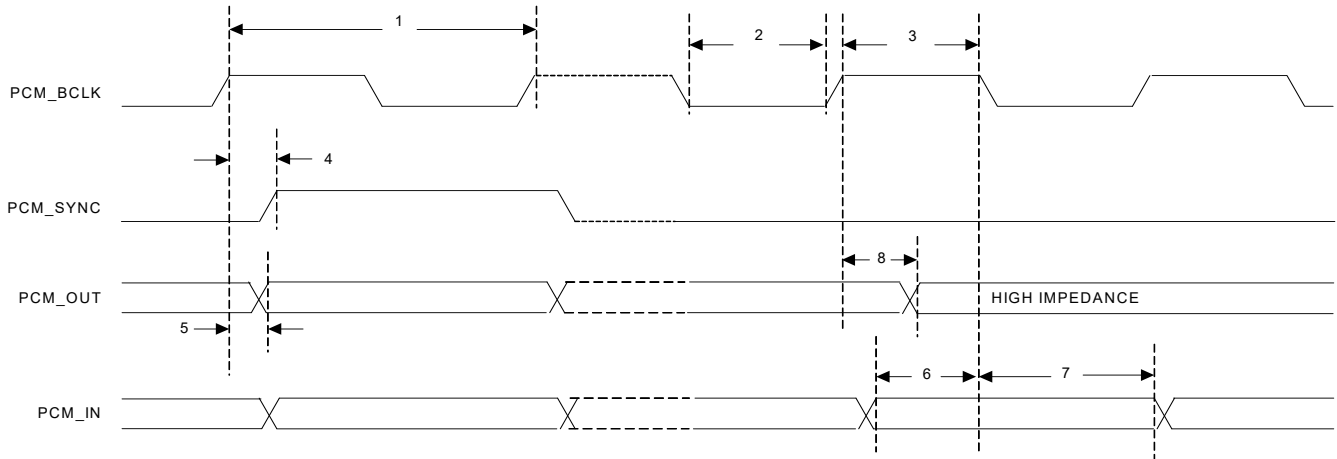

Table 5. PCM Interface Timing Specifications (Short Frame Sync, Master Mode)

Reference	Characteristics	Min	Typ	Max	Unit
1	PCM bit clock frequency	–	–	12	MHz
2	PCM bit clock LOW	41	–	–	ns
3	PCM bit clock HIGH	41	–	–	ns
4	PCM_SYNC delay	0	–	25	ns
5	PCM_OUT delay	0	–	25	ns
6	PCM_IN setup	8	–	–	ns
7	PCM_IN hold	8	–	–	ns
8	Delay from rising edge of PCM_BCLK during last bit period to PCM_OUT becoming high impedance	0	–	25	ns

Short Frame Sync, Slave Mode

Figure 12. PCM Timing Diagram (Short Frame Sync, Slave Mode)

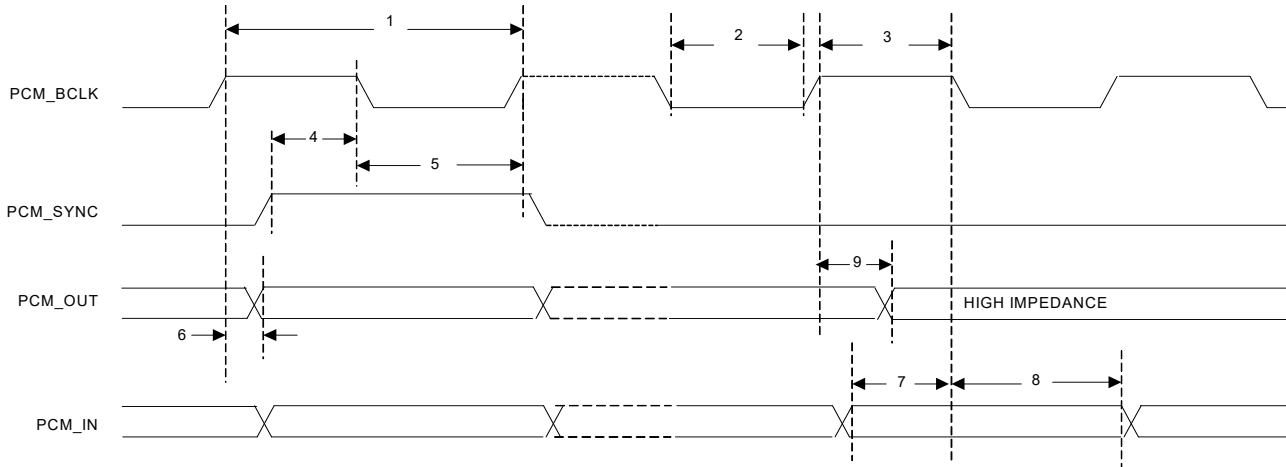

Table 6. PCM Interface Timing Specifications (Short Frame Sync, Slave Mode)

Reference	Characteristics	Min	Typ	Max	Unit
1	PCM bit clock frequency	–	–	12	MHz
2	PCM bit clock LOW	41	–	–	ns
3	PCM bit clock HIGH	41	–	–	ns
4	PCM_SYNC setup	8	–	–	ns
5	PCM_SYNC hold	8	–	–	ns
6	PCM_OUT delay	0	–	25	ns
7	PCM_IN setup	8	–	–	ns
8	PCM_IN hold	8	–	–	ns
9	Delay from rising edge of PCM_BCLK during last bit period to PCM_OUT becoming high impedance	0	–	25	ns

Long Frame Sync, Master Mode

Figure 13. PCM Timing Diagram (Long Frame Sync, Master Mode)

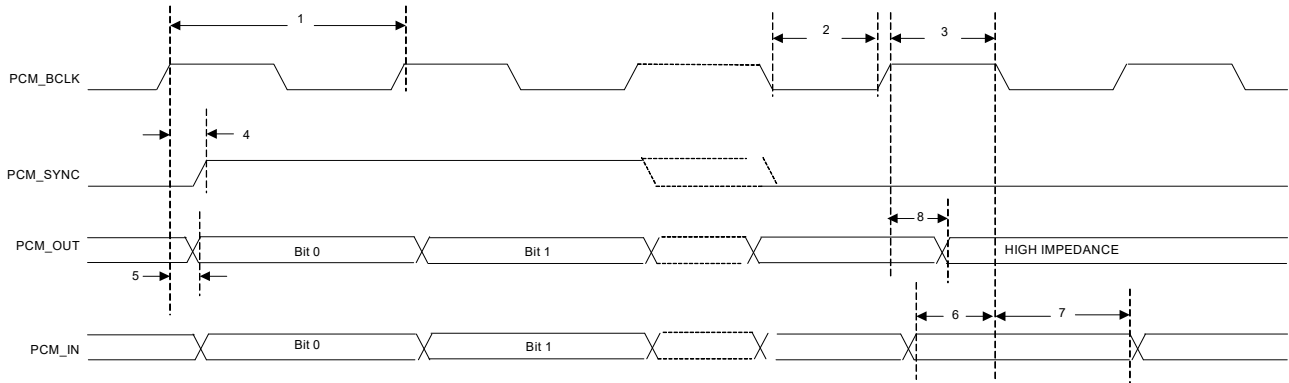

Table 7. PCM Interface Timing Specifications (Long Frame Sync, Master Mode)

Reference	Characteristics	Min	Typ	Max	Unit
1	PCM bit clock frequency	–	–	12	MHz
2	PCM bit clock LOW	41	–	–	ns
3	PCM bit clock HIGH	41	–	–	ns
4	PCM_SYNC delay	0	–	25	ns
5	PCM_OUT delay	0	–	25	ns
6	PCM_IN setup	8	–	–	ns
7	PCM_IN hold	8	–	–	ns
8	Delay from rising edge of PCM_BCLK during last bit period to PCM_OUT becoming high impedance	0	–	25	ns

Long Frame Sync, Slave Mode

Figure 14. PCM Timing Diagram (Long Frame Sync, Slave Mode)

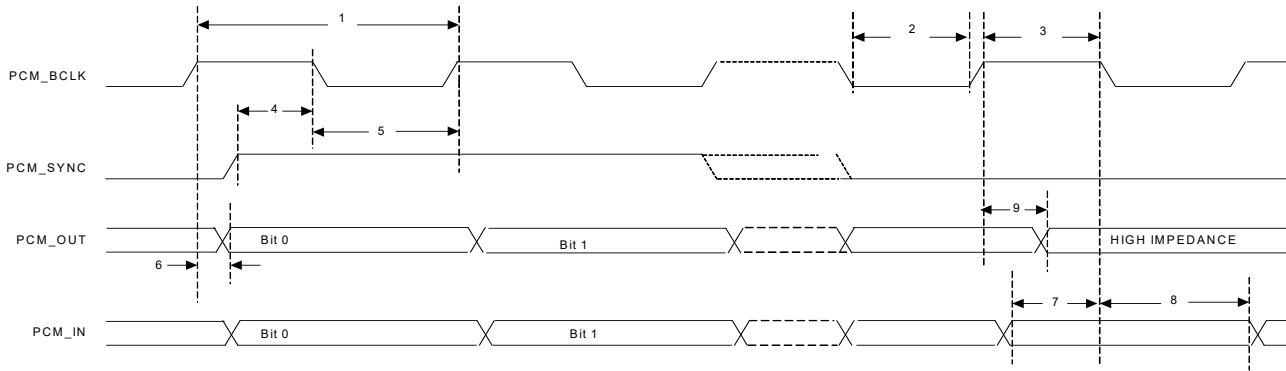

Table 8. PCM Interface Timing Specifications (Long Frame Sync, Slave Mode)

Reference	Characteristics	Min	Typ	Max	Unit
1	PCM bit clock frequency	–	–	12	MHz
2	PCM bit clock LOW	41	–	–	ns
3	PCM bit clock HIGH	41	–	–	ns
4	PCM_SYNC setup	8	–	–	ns
5	PCM_SYNC hold	8	–	–	ns
6	PCM_OUT delay	0	–	25	ns
7	PCM_IN setup	8	–	–	ns
8	PCM_IN hold	8	–	–	ns
9	Delay from rising edge of PCM_BCLK during last bit period to PCM_OUT becoming high impedance	0	–	25	ns

Short Frame Sync, Burst Mode

Figure 15. PCM Burst Mode Timing (Receive Only, Short Frame Sync)

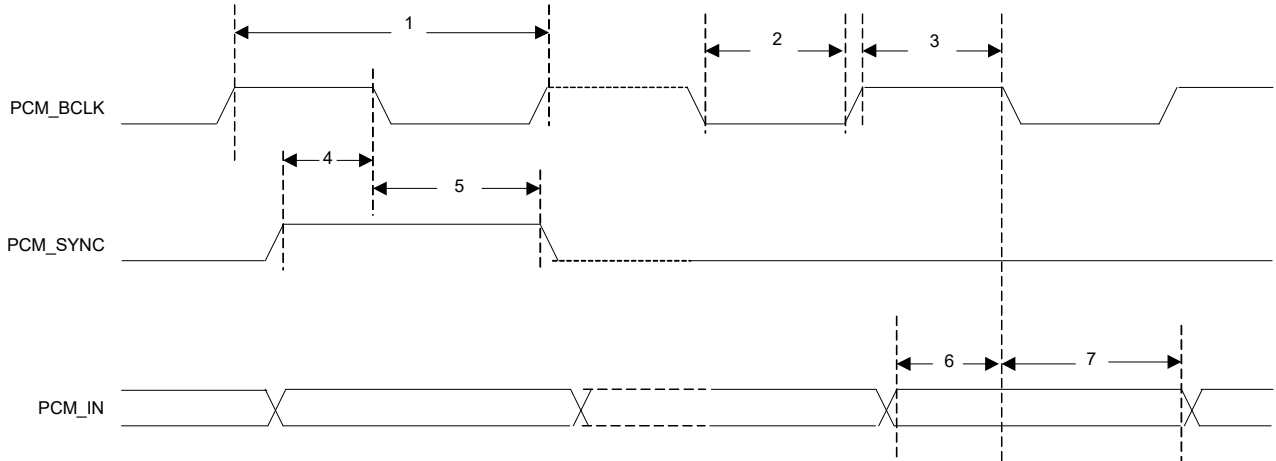

Table 9. PCM Burst Mode (Receive Only, Short Frame Sync)

Reference	Characteristics	Min	Typ	Max	Unit
1	PCM bit clock frequency	–	–	24	MHz
2	PCM bit clock LOW	20.8	–	–	ns
3	PCM bit clock HIGH	20.8	–	–	ns
4	PCM_SYNC setup	8	–	–	ns
5	PCM_SYNC hold	8	–	–	ns
6	PCM_IN setup	8	–	–	ns
7	PCM_IN hold	8	–	–	ns

Long Frame Sync, Burst Mode

Figure 16. PCM Burst Mode Timing (Receive Only, Long Frame Sync)

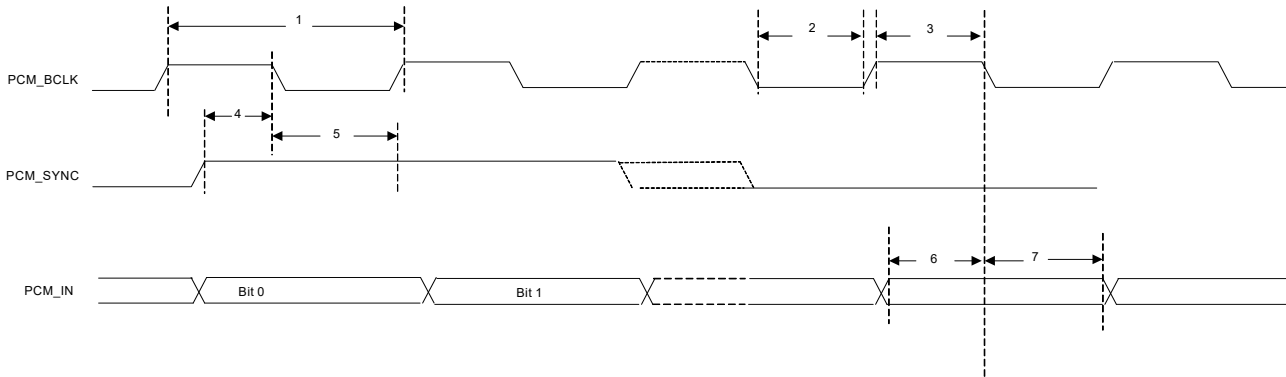

Table 10. PCM Burst Mode (Receive Only, Long Frame Sync)

Reference	Characteristics	Min	Typ	Max	Unit
1	PCM bit clock frequency	–	–	24	MHz
2	PCM bit clock LOW	20.8	–	–	ns
3	PCM bit clock HIGH	20.8	–	–	ns
4	PCM_SYNC setup	8	–	–	ns
5	PCM_SYNC hold	8	–	–	ns
6	PCM_IN setup	8	–	–	ns
7	PCM_IN hold	8	–	–	ns

7.2 UART Interface

The UART is a standard 4-wire interface (RX, TX, RTS, and CTS) with adjustable baud rates from 9600 bps to 4.0 Mbps. The interface features an automatic baud rate detection capability that returns a baud rate selection. Alternatively, the baud rate may be selected through a vendor-specific UART HCI command.

UART has a 1040-byte receive FIFO and a 1040-byte transmit FIFO to support EDR. Access to the FIFOs is conducted through the AHB interface through either DMA or the CPU. The UART supports the Bluetooth UART HCI specification: H4 and a custom Extended H4. The default baud rate is 115.2 Kbaud.

The CYW4373 UART can perform XON/XOFF flow control and includes hardware support for the Serial Line Input Protocol (SLIP). It can also perform wake-on activity. For example, activity on the RX or CTS inputs can wake the chip from a sleep state.

Normally, the UART baud rate is set by a configuration record downloaded after device reset, or by automatic baud rate detection, and the host does not need to adjust the baud rate. Support for changing the baud rate during normal HCI UART operation is included through a vendor-specific command that allows the host to adjust the contents of the baud rate registers. The CYW4373 UARTs operate correctly with the host UART as long as the combined baud rate error of the two devices is within ±2%.

Table 11. Example of Common Baud Rates

Desired Rate	Actual Rate	Error (%)
4000000	4000000	0.00
3692000	3692308	0.01
3000000	3000000	0.00
2000000	2000000	0.00
1500000	1500000	0.00
1444444	1454544	0.70
921600	923077	0.16
460800	461538	0.16
230400	230796	0.17
115200	115385	0.16
57600	57692	0.16
38400	38400	0.00
28800	28846	0.16
19200	19200	0.00
14400	14423	0.16
9600	9600	0.00

Figure 17. UART Timing

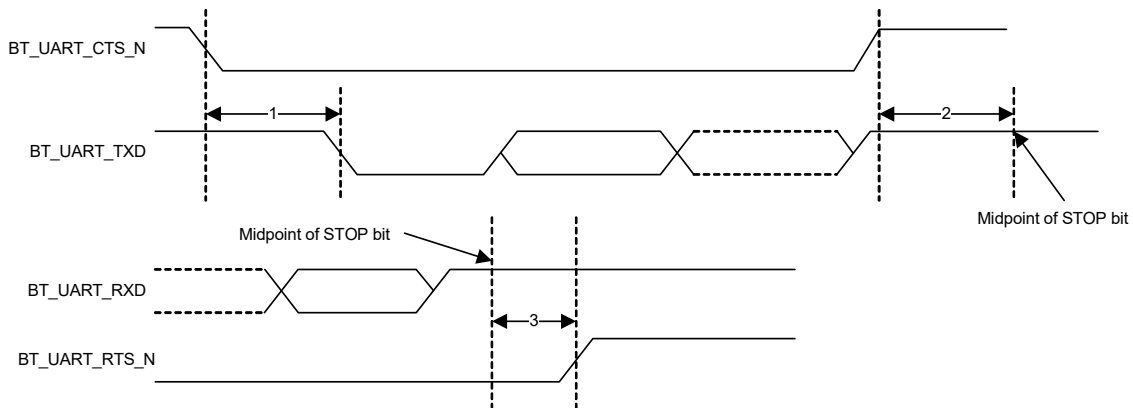

Table 12. UART Timing Specifications

Ref	Characteristics	Min	Typ	Max	Unit
1	Delay time, BT_UART_CTS_N low to BT_UART_TXD valid	–	–	1.5	Bit periods
2	Setup time, BT_UART_CTS_N high before midpoint of stop bit	–	–	0.5	Bit periods
3	Delay time, midpoint of stop bit to BT_UART_RTS_N high	–	–	0.5	Bit periods

7.3 I²S Interface

The CYW4373 supports an I²S digital audio port for Bluetooth audio. The I²S signals are:

- I²S clock: I²S SCK
- I²S Word Select: I²S WS
- I²S Data Out: I²S SDO
- I²S Data In: I²S SDI

The I²S signals are multiplexed behind the PCM signals. The table below provides the signal mapping.

Table 13. I²S Signal Mapping

PCM Signals	I ² S Signals
BT_PCM_CLK	I ² S_SCK
BT_PCM_IN	I ² S_SDI
BT_PCM_OUT	I ² S_SDO
BT_PCM_SYNC	I ² S_WS

I²S SCK and I²S WS become outputs in master mode and inputs in slave mode, while I²S SDO always stays as an output. The channel word length is 16 bits and the data is justified so that the MSB of the left-channel data is aligned with the MSB of the I²S bus, per the I²S specification. The MSB of each data word is transmitted one bit clock cycle after the I²S WS transition, synchronous with the falling edge of bit clock. Left-channel data is transmitted when I²S WS is LOW, and right-channel data is transmitted when I²S WS is HIGH. Data bits sent by the CYW4373 are synchronized with the falling edge of I2S_SCK and should be sampled by the receiver on the rising edge of I2S_SSCK.

The clock rate in master mode is either of the following:

- 48 kHz x 32 bits per frame = 1.536 MHz
- 48 kHz x 50 bits per frame = 2.400 MHz

The master clock is generated from the input reference clock using a N/M clock divider. In the slave mode, any clock rate is supported to a maximum of 3.072 MHz.

7.3.1 I²S Timing

Note: Timing values specified in Table 14 are relative to high and low threshold levels.

Table 14. Timing for I²S Transmitters and Receivers

	Transmitter				Receiver				Notes
	Lower Limit		Upper Limit		Lower Limit		Upper Limit		
	Min.	Max.	Min.	Max.	Min.	Max.	Min.	Max.	
Clock Period T	T _{tr}	–	–	–	T _r	–	–	–	1
Master Mode: Clock generated by transmitter or receiver									
HIGH t _{HC}	0.35T _{tr}	–	–	–	0.35T _{tr}	–	–	–	2
LOW t _{LC}	0.35T _{tr}	–	–	–	0.35T _{tr}	–	–	–	2
Slave Mode: Clock accepted by transmitter or receiver									
HIGH t _{HC}	–	0.35T _{tr}	–	–	–	0.35T _{tr}	–	–	3
LOW t _{LC}	–	0.35T _{tr}	–	–	–	0.35T _{tr}	–	–	3
Rise time t _{RC}	–	–	0.15T _{tr}	–	–	–	–	–	4
Transmitter									
Delay t _{dtr}	–	–	–	0.8T	–	–	–	–	5
Hold time t _{htr}	0	–	–	–	–	–	–	–	4
Receiver									
Setup time t _{sr}	–	–	–	–	–	0.2T _r	–	–	6
Hold time t _{hr}	–	–	–	–	–	0	–	–	6

1. The system clock period T must be greater than T_{tr} and T_r because both the transmitter and receiver have to be able to handle the data transfer rate.
2. At all data rates in master mode, the transmitter or receiver generates a clock signal with a fixed mark/space ratio. For this reason, t_{HC} and t_{LC} are specified with respect to T.
3. In slave mode, the transmitter and receiver need a clock signal with minimum HIGH and LOW periods so that they can detect the signal. So long as the minimum periods are greater than 0.35T_r, any clock that meets the requirements can be used.
4. Because the delay (t_{dtr}) and the maximum transmitter speed (defined by T_{tr}) are related, a fast transmitter driven by a slow clock edge can result in t_{dtr} not exceeding t_{RC} which means t_{htr} becomes zero or negative. Therefore, the transmitter has to guarantee that t_{htr} is greater than or equal to zero, so long as the clock rise-time t_{RC} is not more than t_{RCmax}, where t_{RCmax} is not less than 0.15T_{tr}.
5. To allow data to be clocked out on a falling edge, the delay is specified with respect to the rising edge of the clock signal and T, always giving the receiver sufficient setup time.
6. The data setup and hold time must not be less than the specified receiver setup and hold time.

Note: The time periods specified in Figure 18 and Figure 19 are defined by the transmitter speed. The receiver specifications must match transmitter performance.

Figure 18. I²S Transmitter Timing

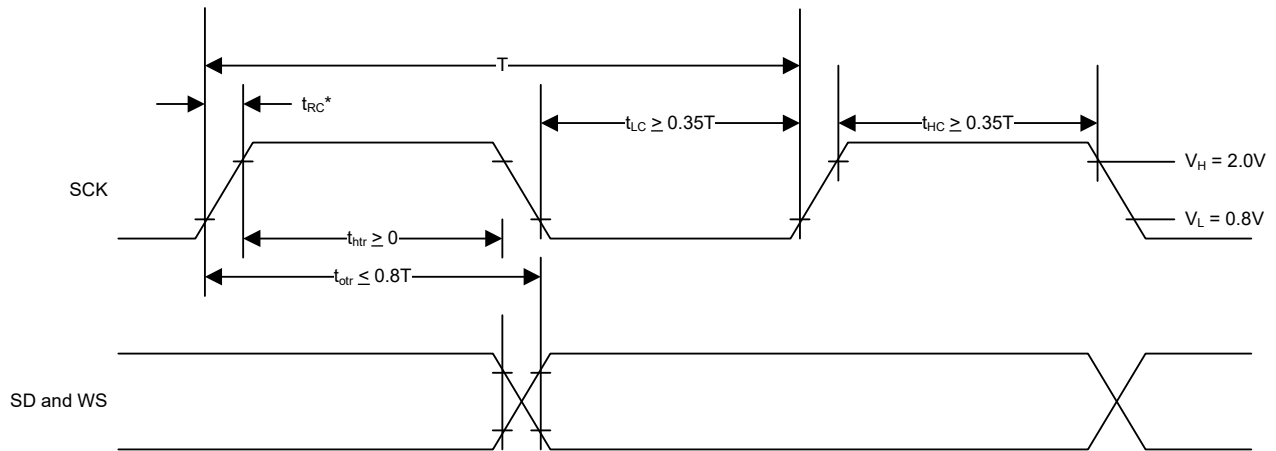

T = Clock period
 T_{tr} = Minimum allowed clock period for transmitter
 $T = T_{tr}$
 * t_{RC} is only relevant for transmitters in slave mode.

Figure 19. I²S Receiver Timing

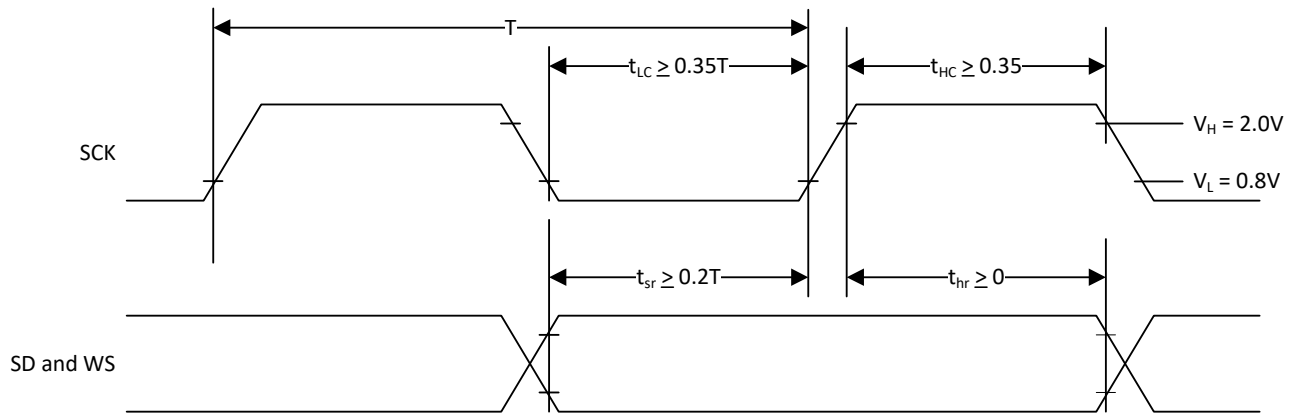

T = Clock period
 T_r = Minimum allowed clock period for transmitter
 $T > T_r$

7.4 BT USB Interface

Host Interface block diagram of the shared USB for BT is shown in below.

Figure 20. BT USB Interface

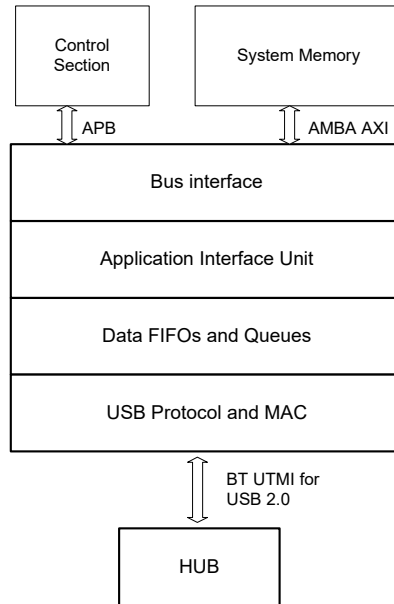

The CYW4373 has an USB 2.0 protocol engine that supports the following hardware interface:

- Advanced microcontroller bus architecture (AMBA) advanced extensible interface (AXI) for an AXI interconnect
- AMBA advanced peripheral bus (APB) for device controller (BDC) certificate signing request (CSR) access
- Interrupts
- BT UTMI interface connected to HS HUB

The device properties and endpoint (0 to 6) are stored inside the CYW4373 system memory, in which each endpoint consists of transfer ring and is linked to data buffers.

8. WLAN Global Functions

8.1 WLAN CPU and Memory Subsystem

The CYW4373 WLAN section includes an integrated ARM Cortex-R4 32-bit processor with internal RAM and ROM. The Arm Cortex-R4 is a low-power processor that features low gate count, low interrupt latency, and low-cost debug capabilities.

At 0.19 $\mu\text{W}/\text{MHz}$, the Cortex-R4 is the most power efficient general-purpose microprocessor available, outperforming 8 and 16-bit devices on MIPS/ μW . It supports integrated sleep modes.

Using multiple technologies to reduce cost, the Arm Cortex-R4 offers improved memory utilization, reduced pin overhead, and reduced silicon area. It supports independent buses for Code and Data access (ICode/DCode and System buses), and extensive debug features including real time trace of program execution.

On-chip memory for the CPU includes 896 KB SRAM and 896 KB ROM.

8.2 One-Time Programmable Memory

Various hardware configuration parameters may be stored in an internal 6144-bit (768 bytes) OTP memory, which is read by the system software after device reset. In addition, customer-specific parameters, including the system vendor ID and the MAC address can be stored, depending on the specific board design.

The initial state of all bits in an unprogrammed OTP device is 0. After any bit is programmed to a 1, it cannot be reprogrammed to 0. The entire OTP array can be programmed in a single write cycle using a utility provided with the Cypress WLAN manufacturing test tools. Alternatively, multiple write cycles can be used to selectively program specific bytes, but only bits which are still in the 0 state can be altered during each programming cycle.

Prior to OTP programming, all values should be verified using the appropriate editable nvram.txt file, which is provided with the reference board design package.

8.3 GPIO Interface

The following number of GPIO pins are available on the WLAN section of the CYW4373 that can be used to connect to various external devices:

- WLBGA package – 10 GPIOs

Upon power-up and reset, these pins become tristated. Subsequently, they can be programmed to be either input or output pins via the GPIO control register. In addition, the GPIO pins can be assigned to various other functions.

8.4 External Coexistence Interface

External handshake interface is available to enable signaling between the device and an external co-located wireless device, such as Zigbee or LTE to manage wireless medium sharing for optimum performance.

8.4.1 LTE Coexistence Interface

Figure 21 shows the WCI-2 LTE coexistence interface_b. See Table 12 “UART Timing Specifications” for UART baud rate.

Figure 21. Cypress GCI or BT-SIG WCI-2 Coexistence Interface for Cypress BT/ZigBee radios or LTE radios

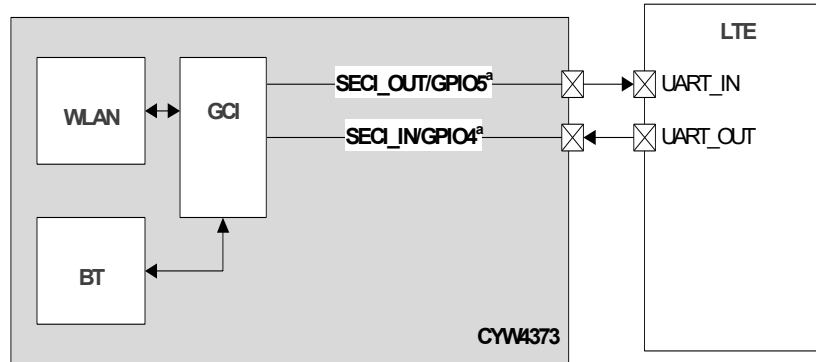

8.4.2 3- Wire (Zigbee) Coexistence Interface

Figure 22, Figure 23 and Table 15 define external 3-wire interface_b.

Figure 22. 3-Wire Coexistence Interface for 3rd party BT/ZigBee radios

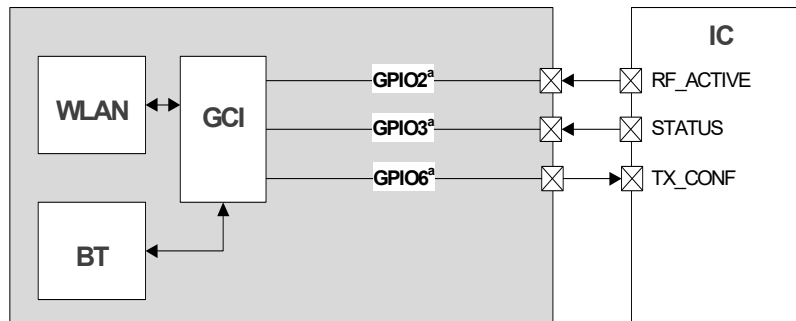

Table 15. 3-Wire External Coexistence Interface

GPIO Name	Coexistence Signal	Type	Comment
GPIO_2	RF_ACTIVE	Input	Request indication from external device for access
GPIO_3	STATUS	Input	Indicates priority (within T2) and TX/RX (after T2)
GPIO_6	TX_CONF	Output	Grant of access indication to external device

Notes:

- GPIO_2, GPIO_3, GPIO_4, GPIO_5 and GPIO_6 are multiplexed with the JTAG interface using the JTAG_SEL pin.
- The 2- and 3-wire coexistence interfaces are not supported by default on the CYW94373WLSUSB reference design. Please contact the Cypress support team to understand how to use these interfaces.

Figure 23. 3-Wire External Coexistence Interface Timing Diagram

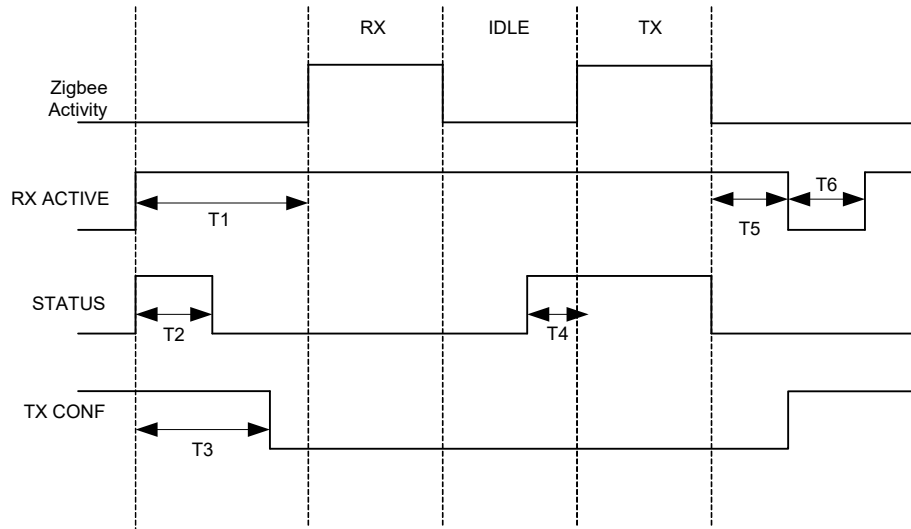

Notes on Timing Diagram

- T1: Advance assertion time of RF Active from actual TX or RX
 - Minimum 100 us
- T2: Priority indication on Status Line
 - Expected to start at the same time as RF Active
 - Minimum 30 us
 - Maximum 50 us
 - 1 – High Priority, 0 – Low Priority
- After 50 us, the Status line is used to indicate TX/RX
 - 1 – TX, 0 – RX
- T3 – TX CONF assertion delay from RF ACTIVE
 - Maximum 90 us
- T4 – Advance assertion time of TX/RX indication on status line for subsequent frames without RF ACTIVE toggling
 - Minimum 30 us
- T5 – RF ACTIVE de-assertion delay after end of frame exchange
 - Expected to be as low as possible (~0 us) to improve overall efficiency
- T6 – RF ACTIVE de-assertion
 - Minimum 16 us

3-wire Coexistence interface protocol details:

- External device asserts RF ACTIVE (in advance) when it wants access to the wireless medium
 - 1 – Access Requested
 - 0 – Access not requested
- It indicates priority of the access requested in a specified window (50 us counted from assertion of RF ACTIVE) on STATUS line
 - 1 – High Priority
 - 0 – Low Priority
- After indicating priority on STATUS line it indicates TX/RX indication on the same STATUS line (after 50 us window)
 - 1 – TX
 - 0 – RX
- Arbitrating device (WiFi) will decide based on the relative priority of the different requests (WiFi internal and external) and either grant or reject the request. This is indicated using the TX CONF signal
 - 1 – Access Denied
 - 0 – Access Granted

8.5 UART Interface

A high-speed 4-wire CTS/RTS UART interface can be enabled by software as an alternate function on GPIO pins. Provided primarily for debugging during development, this UART enables the CYW4373 to operate as RS-232 data termination equipment (DTE) for exchanging and managing data with other serial devices. It is compatible with the industry standard 16550 UART, and provides a FIFO size of 64 × 8 in each direction.

8.6 JTAG Interface

The CYW4373 supports IEEE 1149.1 JTAG boundary scan to access the chip's internal blocks and backplane for system bring-up and debugging. This interface allows Cypress engineers to assist customers with proprietary debug and characterization test tools.

The debug access port (DAP) embedded in the ARM processor supports both SWD and JTAG interfaces and can be switched from one to the other through a specific sequence on the TMS lines. In addition to the ARM debug interface, an internal JTAG master on the DAP allows access to test access points (TAPs) in the CYW4373 for hardware debugging.

9. WLAN Host Interfaces

9.1 WLAN USB 2.0 Interface

Figure 24 details the Host Interface block diagram of the shared USB 2.0 for WLAN

Figure 24. WLAN USB 2.0 Host Interface block diagram

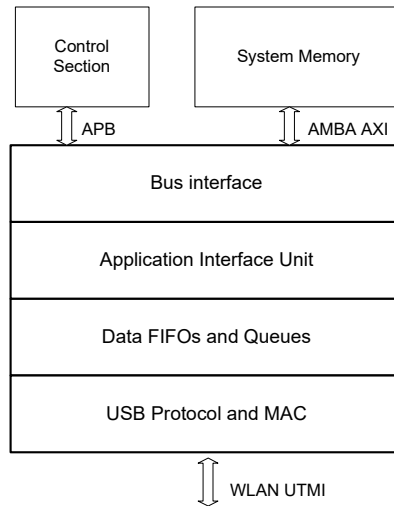

The CYW4373 has an USB 2.0 protocol engine that supports the following hardware interface:

- Advanced microcontroller bus architecture (AMBA) advanced extensible interface (AXI) for an AXI interconnect
- AMBA advanced peripheral bus (APB) for device controller (BDC) certificate signing request (CSR) access.
- Interrupts
- WLAN UTMI interface connected HS Hub.

The device properties and endpoint (0 to 5) are stored inside the CYW4373 system memory, in which each endpoint consists of transfer ring and is linked to data buffers.

9.2 SDIO v3.0

All three package options of the CYW4373 WLAN section provide support for SDIO v3.0, including the new UHS-I modes:

- DS: Default speed (DS) up to 25 MHz, including 1- and 4-bit modes (3.3 V signaling).
- HS: High speed up to 50 MHz (3.3 V signaling).
- SDR12: SDR up to 25 MHz (1.8 V signaling).
- SDR25: SDR up to 50 MHz (1.8 V signaling).
- SDR50: SDR up to 100 MHz (1.8 V signaling).
- SDR104: SDR up to 208 MHz (1.8 V signaling)
- DDR50: DDR up to 50 MHz (1.8 V signaling).

Note: The CYW4373 is backward compatible with SDIO v2.0 host interfaces.

The SDIO interface also has the ability to map the interrupt signal on to a GPIO pin for applications requiring an interrupt different from the one provided by the SDIO interface. The ability to force control of the gated clocks from within the device is also provided. SDIO mode is enabled by strapping options. See [Table 19](#) for strapping options.

The following three functions are supported:

- Function 0 Standard SDIO function (Max BlockSize/ByteCount = 32B)
- Function 1 Backplane Function to access the internal system-on-chip (SoC) address space (Max BlockSize/ByteCount = 64B)
- Function 2 WLAN Function for efficient WLAN packet transfer through DMA (Max BlockSize/ByteCount = 512B).
- Function 3 BT Function for efficient WLAN packet transfer through DMA

9.2.1 SDIO Pins

Table 16. SDIO Pin Description

SD 4-Bit Mode		SD 1-Bit Mode	
DATA0	Data line 0	DATA	Data line
DATA1	Data line 1 or Interrupt	IRQ	Interrupt
DATA2	Data line 2 or Read Wait	RW	Read Wait
DATA3	Data line 3	N/C	Not used
CLK	Clock	CLK	Clock
CMD	Command line	CMD	Command line

Figure 25. Signal Connections to SDIO Host (SD 4-Bit Mode)

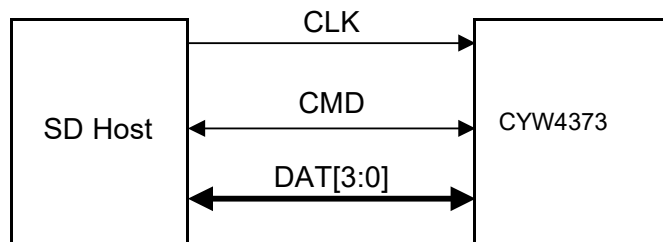
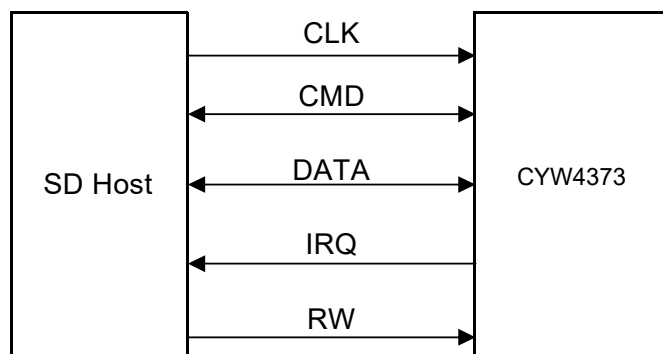

Figure 26. Signal Connections to SDIO Host (SD 1-Bit Mode)



Note: Per Section 6 of the SDIO specification, pull-ups in the 10 kΩ to 100 kΩ range are required on the four DATA lines and the CMD line. This requirement must be met during all operating states either through the use of external pull-up resistors or through proper programming of the SDIO host's internal pull-ups.

10. Shared Host Interfaces

10.1 Shared BT and WLAN USB 2.0 Interface

Figure 27 details the Host Interface block diagram of the shared USB 2.0 hub for WLAN and BT.

Figure 27. WLAN/BT USB 2.0 Host Interface block diagram

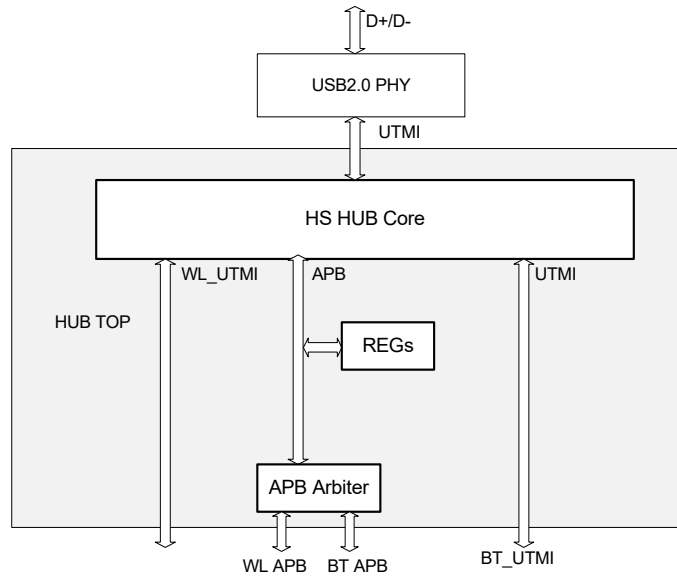

The CYW4373 has a USB2.0-PHY and HS HUB which can enable shared USB2.0 interface between WLAN and BT. The key features of this USB2.0-PHY and HS HUB are as follows:

- D+/D- as USB signaling
- HS HUB is connected to WLAN and BT via UTMI interface.
- AMBA advanced peripheral bus (APB) for reading writing APB registers of HS HUB and other registers. These registers are accessible by both WLAN and BT through an arbiter.

Figure 28. WLAN/BT USB Timing

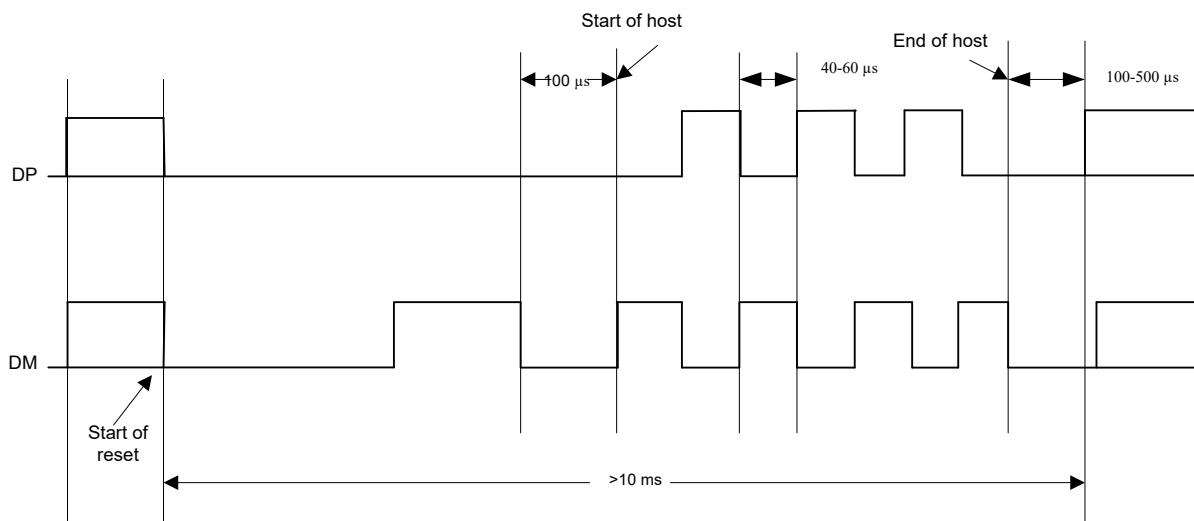

11. Wireless LAN MAC and PHY

11.1 IEEE 802.11ac MAC

The CYW4373 WLAN MAC is designed to support high-throughput operation with low-power consumption. It does so without compromising the Bluetooth coexistence policies, thereby enabling optimal performance over both networks. In addition, several power saving modes have been implemented that allow the MAC to consume very little power while maintaining network-wide timing synchronization. The architecture diagram of the MAC is shown in Figure 29.

The following sections provide an overview of the important modules in the MAC.

Figure 29. WLAN MAC Architecture

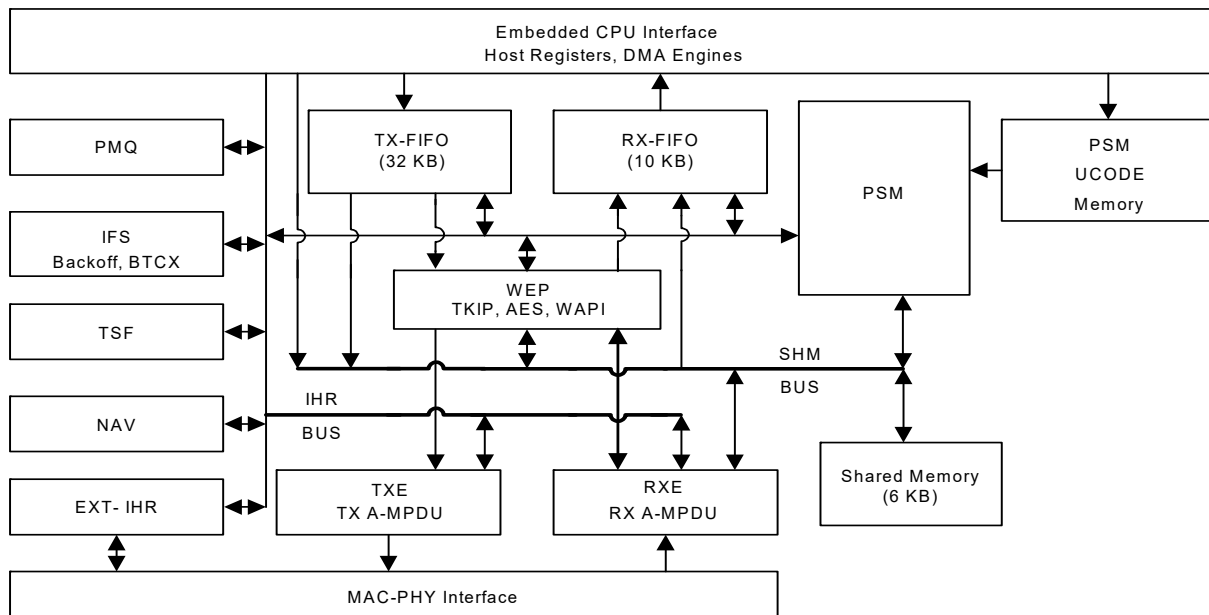

The CYW4373 WLAN media access controller (MAC) supports features specified in the IEEE 802.11 base standard, and amended by IEEE 802.11n/ac. The key MAC features include:

- Enhanced MAC for supporting IEEE 802.11ac features
- Transmission and reception of aggregated MPDUs (A-MPDUs) for very high throughput (VHT)
- Support for power management schemes, including WMM power-save, power-save multi-poll (PSMP) and multiphase PSMP operation
- Support for immediate ACK and Block-ACK policies
- Interframe space timing support, including RIFS
- Support for RTS/CTS and CTS-to-self frame sequences for protecting frame exchanges
- Back-off counters in hardware for supporting multiple priorities as specified in the WMM specification
- Timing synchronization function (TSF), network allocation vector (NAV) maintenance, and target beacon transmission time (TBTT) generation in hardware and capturing the TSF timer on an external time synchronization pulse
- Hardware offload for AES-CCMP, legacy WPA TKIP, legacy WEP ciphers, WAPI, and support for key management
- Support for coexistence with Bluetooth and other external radios
- Programmable independent basic service set (IBSS) or infrastructure basic service set functionality
- Statistics counters for MIB support

11.1.1 Programmable State Machine (PSM)

The PSM is a microcoded engine, which provides most of the low-level control to the hardware, to implement the IEEE 802.11 specification. It is a microcontroller that is highly optimized for flow control operations, which are predominant in implementations of communication protocols. The instruction set and fundamental operations are simple and general, which allows algorithms to be optimized until very late in the design process. It also allows for changes to the algorithms to track evolving IEEE 802.11 specifications.

The PSM fetches instructions from the microcode memory. It uses the shared memory to obtain operands for instructions, as a data store, and to exchange data between both the host and the MAC data pipeline (via the SHM bus). The PSM also uses a scratchpad memory (similar to a register bank) to store frequently accessed and temporary variables.

The PSM exercises fine-grained control over the hardware engines, by programming internal hardware registers (IHR). These IHRs are co-located with the hardware functions they control, and are accessed by the PSM via the IHR bus.

The PSM fetches instructions from the microcode memory using an address determined by the program counter, instruction literal, or a program stack. For ALU operations the operands are obtained from shared memory, scratchpad, IHRs, or instruction literals, and the results are written into the shared memory, scratchpad, or IHRs.

There are two basic branch instructions: conditional branches and ALU based branches. To better support the many decision points in the IEEE 802.11 algorithms, branches can depend on either a readily available signals from the hardware modules (branch condition signals are available to the PSM without polling the IHRs), or on the results of ALU operations.

11.1.2 Wired Equivalent Privacy (WEP)

The WEP engine encapsulates all the hardware accelerators to perform the encryption and decryption, and MIC computation and verification. The accelerators implement the following cipher algorithms: legacy WEP, WPA TKIP, WPA2 AES-CCMP.

The PSM determines, based on the frame type and association information, the appropriate cipher algorithm to be used. It supplies the keys to the hardware engines from an on-chip key table. The WEP interfaces with the TXE to encrypt and compute the MIC on transmit frames, and the RXE to decrypt and verify the MIC on receive frames.

11.1.3 Transmit Engine (TXE)

The TXE constitutes the transmit data path of the MAC. It coordinates the DMA engines to store the transmit frames in the TXFIFO. It interfaces with WEP module to encrypt frames, and transfers the frames across the MAC-PHY interface at the appropriate time determined by the channel access mechanisms.

The data received from the DMA engines are stored in transmit FIFOs. The MAC supports multiple logical queues to support traffic streams that have different QoS priority requirements. The PSM uses the channel access information from the IFS module to schedule a queue from which the next frame is transmitted. Once the frame is scheduled, the TXE hardware transmits the frame based on a precise timing trigger received from the IFS module.

The TXE module also contains the hardware that allows the rapid assembly of MPDUs into an A-MPDU for transmission. The hardware module aggregates the encrypted MPDUs by adding appropriate headers and pad delimiters as needed.

11.1.4 Receive Engine (RXE)

The RXE constitutes the receive data path of the MAC. It interfaces with the DMA engine to drain the received frames from the RXFIFO. It transfers bytes across the MAC-PHY interface and interfaces with the WEP module to decrypt frames. The decrypted data is stored in the RXFIFO.

The RXE module contains programmable filters that are programmed by the PSM to accept or filter frames based on several criteria such as receiver address, BSSID, and certain frame types.

The RXE module also contains the hardware required to detect A-MPDUs, parse the headers of the containers, and disaggregate them into component MPDUS.

11.1.5 Interframe Space (IFS) timing

The IFS module contains the timers required to determine interframe space timing including RIFS timing. It also contains multiple backoff engines required to support prioritized access to the medium as specified by WMM.

The interframe spacing timers are triggered by the cessation of channel activity on the medium, as indicated by the PHY. These timers provide precise timing to the TXE to begin frame transmission. The TXE uses this information to send response frames or perform transmit frame-bursting (RIFS or SIFS separated, as within a TXOP).

The backoff engines (for each access category) monitor channel activity, in each slot duration, to determine whether to continue or pause the backoff counters. When the backoff counters reach 0, the TXE gets notified, so that it may commence frame transmission. In the event of multiple backoff counters decrementing to 0 at the same time, the hardware resolves the conflict based on policies provided by the PSM.

The IFS module also incorporates hardware that allows the MAC to enter a low-power state when operating under the IEEE power save mode. In this mode, the MAC is in a suspended state with its clock turned off. A sleep timer, whose count value is initialized by the PSM, runs on a slow clock and determines the duration over which the MAC remains in this suspended state. Once the timer expires the MAC is restored to its functional state. The PSM updates the TSF timer based on the sleep duration ensuring that the TSF is synchronized to the network.

The IFS module also contains the PTA hardware that assists the PSM in Bluetooth coexistence functions.

11.1.6 Timing Synchronization function (TSF)

The TSF module maintains the TSF timer of the MAC. It also maintains the target beacon transmission time (TBTT). The TSF timer hardware, under the control of the PSM, is capable of adopting timestamps received from beacon and probe response frames in order to maintain synchronization with the network.

The TSF module also generates trigger signals for events that are specified as offsets from the TSF timer, such as uplink and downlink transmission times used in PSMP.

11.1.7 Network Allocation Vector (NAV)

The NAV timer module is responsible for maintaining the NAV information conveyed through the duration field of MAC frames. This ensures that the MAC complies with the protection mechanisms specified in the standard.

The hardware, under the control of the PSM, maintains the NAV timer and updates the timer appropriately based on received frames. This timing information is provided to the IFS module, which uses it as a virtual carrier-sense indication.

11.1.8 MAC-PHY Interface

The MAC-PHY interface consists of a data path interface to exchange RX/TX data from/to the PHY. In addition, there is an programming interface, which can be controlled either by the host or the PSM to configure and control the PHY. This block also captures two sets of TSF and AVB timers when an external trigger is detected. The trigger can be programmed to occur on any edge of either any GPIO or the TimeSyncSlowIn, TimeSyncFastIn, or selected coexistence inputs.

11.2 IEEE 802.11ac PHY

The CYW4373 WLAN Digital PHY is designed to comply with IEEE 802.11a/b/g/n/ac single-stream specifications to provide wireless LAN connectivity supporting data rates from 1 Mbps to 433.3 Mbps for low-power, high-performance handheld applications.

The PHY has been designed to work in the presence of interference, radio nonlinearity, and various other impairments. It incorporates optimized implementations of the filters, FFT, Viterbi decoder. Efficient algorithms have been designed to achieve maximum throughput and reliability, including algorithms for carrier sense/rejection, frequency/phase/timing acquisition and tracking, channel estimation and tracking. The PHY receiver also contains a robust IEEE 802.11b demodulator. The PHY carrier sense has been tuned to provide high throughput for IEEE 802.11g/11b hybrid networks with Bluetooth coexistence. It has also been designed for shared single antenna systems between WL and BT to support simultaneous RX-RX.

The key PHY features include:

- Programmable data rates from MCS0–MCS8 in 20 MHz and MCS0-MCS9 in 40/80 MHz channels, as specified in IEEE 802.11ac.
- Supports Optional Short GI and Green Field modes in TX and RX.
- All scrambling, encoding, forward error correction, and modulation in the transmit direction and inverse operations in the receive direction.
- Supports IEEE 802.11h/d for worldwide operation.
- Advanced algorithms for low power, enhanced sensitivity, range, and reliability.
- Algorithms to improve performance in presence of Bluetooth.
- Automatic gain control scheme for blocking and non blocking application scenario for cellular applications.
- Closed loop transmit power control.
- Digital RF chip calibration algorithms to handle CMOS RF chip non-idealities.
- On-the-fly channel frequency and transmit power selection.
- Supports per-packet RX antenna diversity.
- Available per-packet channel quality and signal strength measurements.
- Designed to meet FCC and other worldwide regulatory requirements.
- Narrow band (2.5, 5 & 10 MHz channel) WLAN mode for long range

Figure 30. WLAN PHY Block Diagram

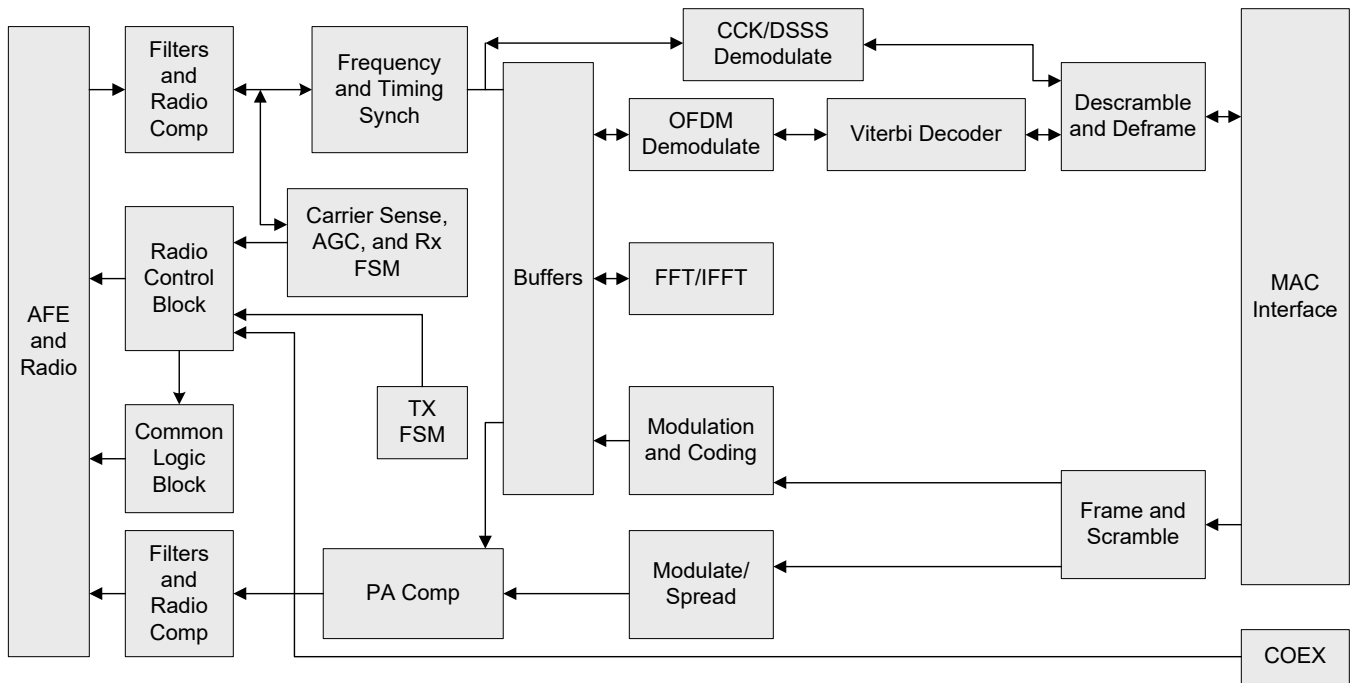

12. WLAN Radio Subsystem

The CYW4373 includes an integrated dual-band WLAN RF transceiver that has been optimized for use in 2.4 GHz and 5 GHz Wireless LAN systems. It has been designed to provide low-power, low-cost, and robust communications for applications operating in the globally available 2.4 GHz unlicensed ISM or 5 GHz U-NII bands. The transmit and receive sections include all on-chip filtering, mixing, and gain control functions.

Ten RF control signals are available to drive external RF switches and support optional external power amplifiers and low-noise amplifiers for each band. See the reference board schematics for further details.

A block diagram of the radio subsystem is shown in [Figure 31](#). Note that integrated on-chip baluns (not shown) convert the fully differential transmit and receive paths to single-ended signal pins.

12.1 Receiver Path

The CYW4373 has a wide dynamic range, direct conversion receiver that employs high order on-chip channel filtering to ensure reliable operation in the noisy 2.4 GHz ISM band or the entire 5 GHz U-NII band. An on-chip low-noise amplifier (LNA) in the 2.4 GHz path is shared between the Bluetooth and WLAN receivers, while the 5 GHz receive path has a dedicated on-chip LNA. Control signals are available that can support the use of optional LNAs for each band, which can increase the receive sensitivity by several dB.

12.2 Transmit Path

Baseband data is modulated and upconverted to the 2.4 GHz ISM or 5-GHz U-NII bands, respectively. Linear on-chip power amplifiers are included, which are capable of delivering high output powers while meeting IEEE 802.11a/b/g/n/ac specifications without the need for external PAs. When using the internal PAs, closed-loop output power control is completely integrated. As an option, external PAs can be used for even higher output power, in which case the closed-loop output power control is provided by means of a-band and g-band TSSI inputs from external power detectors.

12.3 Calibration

The CYW4373 features dynamic and automatic on-chip calibration to continually compensate for temperature and process variations across components. These calibration routines are performed periodically in the course of normal radio operation. Examples of some of the automatic calibration algorithms are baseband filter calibration for optimum transmit and receive performance, and LOFT calibration for carrier leakage reduction. In addition, I/Q Calibration, R Calibration, and VCO Calibration are performed on-chip. No per-board calibration is required in manufacturing test, which helps to minimize the test time and cost in large volume production.

Figure 31. Radio Functional Block Diagram

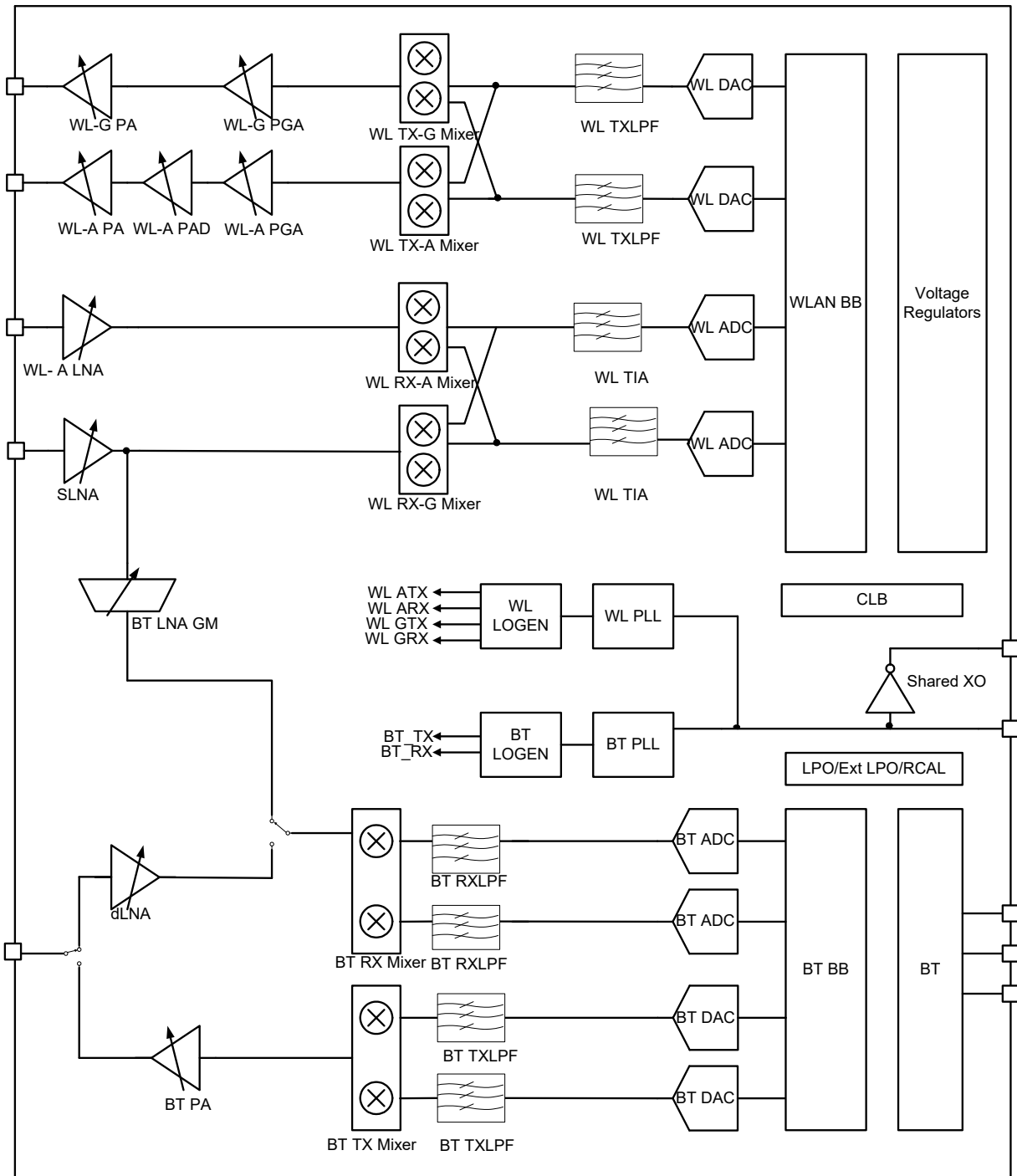

13. Ball Map and Pin Descriptions

13.1 Ball Map

Figure 32. CYW4373 Ball Map Package: 4.51mm x 5.43mm WLBGA 128 Balls, 0.4 mm Ball Pitch Package Bottom View (Balls Facing Up)

	11	10	9	8	7	6	5	4	3	2	1	
A		NC	NC	NC	NC	SDIO_C LK	LDO_VD DBAT5V	VOUT_3P3	LDO_VD D1P5	SR_VDD BAT5V	SR_PV SS	A
B	NC	VSSC	NC	SDIO_DATA 0	SDIO_D ATA 3	SDIO_D ATA 2	VOUT_BT LDO2P5	VOUT_LNL DO	VOUT_C LDO	VOUT_H LDO	SR_VLX	B
C	NC	VSSC	VSSC	VDDC	SDIO_D ATA 1	SDIO_C MD	VSSC	VOUT_ME MLPLDO	BT_REG ON	PMU_AV SS		C
D		RF_SW_CT RL 0	RF_SW_CT RL 1	NC	VSSC	VDDIO		WL_REG_ ON	GPIO_4	GPIO_3	GPIO_1	D
E	RF_SW_CT RL_6	AVSS_BBPL L	AVDD_BBP LL	RF_SW_CT RL_2	RF_SW_ CTRL_3		JTAG_SE L	GPIO_6	GPIO_5	VDDC	GPIO_2	E
F		RF_SW_CT RL 5	VSSC	VDDC	STRAP_ 0	STRAP_ 1	VSSC	VDDC_ME M	GPIO_0	USB2_M ONPLL	USB2_ DM	F
G	WRF_XTAL XON	WRF_XTAL GND1P2	RF_SW_CT RL 4	VDDIO_RF	STRAP_ 2			BT_VDDO	USB2_M ONCDR	USB2_A VSS	USB2_ DP	G
H	WRF_XTAL XOP	WRF_XTAL VDD1P35	WRF_XTAL VDD1P2	WRF_SYNT H VDD3P3			VSSC	BT_GPIO_ 3		USB2_A VDD33	USB2_ RREF	H
J	WRF_PMU_ VDD1P35	WRF_SYNT H VDD1P2	WRF_SYNT H GND	WRF_VCO_ GND	VDDC		VDDC	BT_VDDC	VSSC	LPO_IN	BT_PC M IN	J
K	WRF_RX5G GND	WRF_AFE_ VDD1P35	WRF_GENE RAL_GND	WRF_EXT_ TSSIA	VSSC		BT_GPIO 5	BT_GPIO_ 2	BT_PCM SYNC		BT_PC M CLK	K
L	WRF_RFIN_ 5G	WRF_GENE RAL2_GND	WRF_AFE_ GND	WRF_GPAI O_OUT	BT_VCO VDD1P2	BT_VC OVSS	BT_IFV S	CLK_REQ	BT_PCM _OUT	BT_DEV_ WAKE	BT_VD DC	L
M	WRF_PAOU T 5G	WRF_PA_G ND3P3	WRF_TXMI X VDD	WRF_RX2G GND	BT_LNA VDD1P2	BT_LNA VSS	BT_PLLV SS	BT_VDDC	BT_HOS T WAKE	BT_UAR T CTS_N	BT_UAR T TX P	M
N	WRF_PA_V DD3P3		WRF_PAOU T_2G	WRF_RFIN_ 2G	BT_RF	BT_PAV DD2P5	BT_PLLV DD1P2	BT_IFVDD 1P2	BT_UAR T_RTS_N	BT_UAR T_RXD	VSSC	N
	11	10	9	8	7	6	5	4	3	2	1	

13.2 Pin List by Pin Number

Table 17 lists CYW4373 pins by pin number. For a list of CYW4373 pins by pin name, see Table 19.

Table 17. WLBGA Pin List by Pin Number

Ball	Name
A1	SR_PVSS
A2	SR_VDDBAT5V
A3	LDO_VDD1P5
A4	VOUT_3P3
A5	LDO_VDDBAT5V
A6	SDIO_CLK
A7	NC
A8	NC
A9	NC
A10	NC
A11	–
B1	SR_VLX
B2	VOUT_HLDO
B3	VOUT_CLDO
B4	VOUT_LNLDO
B5	VOUT_BTLDO2P5
B6	SDIO_DATA_2
B7	SDIO_DATA_3
B8	SDIO_DATA_0
B9	NC
B10	VSSC
B11	NC
C1	–
C2	PMU_AVSS
C3	BT_REG_ON
C4	VOUT_MEMPLLDO
C5	VSSC
C6	SDIO_CMD
C7	SDIO_DATA_1
C8	VDDC
C9	VSSC
C10	VSSC
C11	NC
D1	GPIO_1
D2	GPIO_3
D3	GPIO_4
D4	WL_REG_ON

Table 17. WLBGA Pin List by Pin Number (Cont.)

Ball	Name
D5	–
D6	VDDIO
D7	VSSC
D8	NC
D9	RF_SW_CTRL_1
D10	RF_SW_CTRL_0
D11	–
E1	GPIO_2
E2	VDDC
E3	GPIO_5
E4	GPIO_6
E5	JTAG_SEL
E6	–
E7	RF_SW_CTRL_3
E8	RF_SW_CTRL_2
E9	AVDD_BBPLL
E10	AVSS_BBPLL
E11	RF_SW_CTRL_6
F1	USB2_DM
F2	USB2_MONPLL
F3	GPIO_0
F4	VDDC_MEM
F5	VSSC
F6	STRAP_1
F7	STRAP_0
F8	VDDC
F9	VSSC
F10	RF_SW_CTRL_5
F11	–
G1	USB2_DP
G2	USB2_AVSS
G3	USB2_MONCDR
G4	BT_VDDO
G5	–
G6	–
G7	STRAP_2
G8	VDDIO_RF
G9	RF_SW_CTRL_4

Table 17. WLBGA Pin List by Pin Number (Cont.)

Ball	Name
G10	WRF_XTAL_GND1P2
G11	WRF_XTAL_XON
H1	USB2_RREF
H2	USB2_AVDD33
H3	–
H4	BT_GPIO_3
H5	VSSC
H6	–
H7	–
H8	WRF_SYNTH_VDD3P3
H9	WRF_XTAL_VDD1P2
H10	WRF_XTAL_VDD1P35
H11	WRF_XTAL_XOP
J1	BT_PCM_IN
J2	LPO_IN
J3	VSSC
J4	BT_VDDC
J5	VDDC
J6	–
J7	VDDC
J8	WRF_VCO_GND
J9	WRF_SYNTH_GND
J10	WRF_SYNTH_VDD1P2
J11	WRF_PMU_VDD1P35
K1	BT_PCM_CLK
K2	–
K3	BT_PCM_SYN
K4	BT_GPIO_2
K5	BT_GPIO_5
K6	–
K7	VSCC
K8	WRF_EXT_TSSIA
K9	WRF_GENERAL_GND
K10	WRF_AFE_VDD1P35
K11	WRF_RX5G_GND
L1	BT_VDDC
L2	BT_DEV_WAKE
L3	BT_PCM_OUT
L4	CLK_REQ
L5	BT_IFVSS
L6	BT_VCOVSS

Table 17. WLBGA Pin List by Pin Number (Cont.)

Ball	Name
L7	BT_VCOVDD1P2
L8	WRF_GPAIO_OUT
L9	WRF_AFE_GND
L10	WRF_GENERAL2_GND
L11	WRF_RFIN_5G
M1	BT_UART_TXD
M2	BT_UART_CTS_N
M3	BT_HOST_WAKE
M4	BT_VDDC
M5	BT_PLLVSS
M6	BT_LNAVSS
M7	BT_LNAVDD1P2
M8	WRF_RX2G_GND
M9	WRF_TXMIX_VDD
M10	WRF_PA_GND3P3
M11	WRF_PAOUT_5G
N1	VSCC
N2	BT_UART_RXD
N3	BT_UART_RTS_N
N4	BT_IFVDD1P2
N5	BT_PLLVDD1P2
N6	BT_PAVDD2P5
N7	BT_RF
N8	WRF_RFIN_2G
N9	WRF_PAOUT_2G
N10	–
N11	WRF_PA_VDD3P3

13.3 Pin Descriptions

The signal name, type, and description of each pin in the CYW4373 is listed in [Table 18](#). The symbols shown under Type indicate pin directions (I/O = bidirectional, I = input, O = output) and the internal pull-up/pull-down characteristics (PU = weak internal pull-up resistor and PD = weak internal pull-down resistor), if any.

Note: The table below is intended to explain functionality and may not provide all the details necessary for designing a board using CYW4373 (for e.g. the decoupling capacitors necessary). Refer to Cypress's CYW94373WLSUSB reference design and consult Cypress technical support teams for design reviews.

Table 18. Signal Descriptions

Signal Name	WLBGA Ball	Type	Description
WLAN and Bluetooth Receive RF Signal Interface			
WRF_RFIN_2G	N8	I	2.4 GHz Bluetooth and WLAN receiver shared input.
WRF_RFIN_5G	L11	I	5 GHz WLAN receiver input.
WRF_PAOUT_2G	N9	O	2.4 GHz WLAN PA output.
WRF_PAOUT_5G	M11	O	5 GHz WLAN PA output.
WRF_EXT_TSSIA	K8	I	5 GHz TSSI input from an optional external power amplifier/power detector.
WRF_GPAIO_OUT	L8	I/O	GPIO or 2.4 GHz TSSI input from an optional external power amplifier/power detector.
RF Switch Control Lines			
RF_SW_CTRL_0	D10	O	Programmable RF switch control lines. The control lines are programmable via the driver and NVRAM file.
RF_SW_CTRL_1	D9	O	
RF_SW_CTRL_2	E8	O	
RF_SW_CTRL_3	E7	O	
RF_SW_CTRL_4	G9	O	
RF_SW_CTRL_5	F10	O	
RF_SW_CTRL_6	E11	O	
WLAN SDIO Bus Interface			
Note: These signals can also have alternate functionality depending on package and host interface mode.			
SDIO_CLK	A6	I	SDIO clock input.
SDIO_CMD	C6	I/O	SDIO command line.
SDIO_DATA_0	B8	I/O	SDIO data line 0.
SDIO_DATA_1	C7	I/O	SDIO data line 1.
SDIO_DATA_2	B6	I/O	SDIO data line 2.
SDIO_DATA_3	B7	I/O	SDIO data line 3.
WLAN GPIO Interface			
Note: The GPIO signals can be multiplexed via software and the JTAG_SEL pin to behave as various specific functions.			
GPIO_0	F3	I/O	Programmable GPIO pins: GPIO_2 is TCK/SWCLK if JTAG_SEL = 1 GPIO_3 is TMS/SWDIO if JTAG_SEL = 1 GPIO_4 is TDIO if JTAG_SEL = 1 GPIO_5 is TDO if JTAG_SEL = 1 GPIO_6 is TRST_L if JTAG_SEL = 1
GPIO_1	D1	I/O	
GPIO_2	E1	I/O	
GPIO_3	D2	I/O	
GPIO_4	D3	I/O	
GPIO_5	E3	I/O	
GPIO_6	E4	I/O	

Table 18. Signal Descriptions (Cont.)

Signal Name	WLBGA Ball	Type	Description
JTAG Interface			
JTAG_SEL	E5	I/O	JTAG select. This pin must be kept NO CONNECT if the JTAG interface is not used. It must be high to select SWD OR JTAG. When JTAG_SEL = 1: <ul style="list-style-type: none"> ■ GPIO_2 is TCK ■ GPIO_3 is TMS ■ GPIO_4 is TDIO ■ GPIO_5 is TDO ■ GPIO_6 is TRST_L
Clocks			
WRF_XTAL_XOP	H11	I	XTAL oscillator input.
WRF_XTAL_XON	G11	O	XTAL oscillator output.
LPO_IN	J2	I	External sleep clock input (32.768 kHz).
CLK_REQ	L4	O	Reference clock request (shared by BT and WLAN).
Bluetooth Transceiver			
BT_RF	N7	O	Bluetooth PA output and dLNA input.
Bluetooth PCM			
BT_PCM_CLK	K1	I/O	PCM clock; can be master (output) or slave (input).
BT_PCM_IN	J1	I	PCM data input.
BT_PCM_OUT	L3	O	PCM data output.
BT_PCM_SYNC	K3	I/O	PCM sync; can be master (output) or slave (input), or SLIMbus data.
Bluetooth UART			
BT_UART_CTS_N	M2	I	UART clear-to-send. Active-low clear-to-send signal for the HCI UART interface.
BT_UART_RTS_N	N3	O	UART request-to-send. Active-low request-to-send signal for the HCI UART interface. BT LED control pin.
BT_UART_RXD	N2	I	UART serial input. Serial data input for the HCI UART interface. BT RF disable pin 2.
BT_UART_TXD	M1	O	UART serial output. Serial data output for the HCI UART interface.
Bluetooth GPIO			
BT_GPIO_2	K4	I/O	Bluetooth GPIO.
BT_GPIO_3	H4	I/O	Bluetooth GPIO.
BT_GPIO_5	K5	I/O	Bluetooth GPIO.
Shared USB 2.0 Interface			
USB2_DP	G1	IO	Data plus of shared USB2.0 port.
USB2_DM	F1	IO	Data minus of shared USB2.0 port.
USB2_MONCDR	G3	O	CDR monitor for debug.
USB2_MONPLL	F2	O	PLL monitor for debug purpose.
USB2_RREF	H1	IO	Bandgap reference resistor; 4.8K ohm +/-5%.

Table 18. Signal Descriptions (Cont.)

Signal Name	WLBGA Ball	Type	Description
Miscellaneous			
WL_REG_ON	D4	I	Used by PMU to power-up or power down the internal CYW4373 regulators used by the WLAN section. Also, when deasserted, this pin holds the WLAN section in reset. This pin has an internal 200 kΩ pull-down resistor that is enabled by default. It can be disabled through programming.
BT_REG_ON	C3	I	Used by PMU to power-up or power down the internal CYW4373 regulators used by the Bluetooth section. Also, when deasserted, this pin holds the Bluetooth section in reset. This pin has an internal 200 kΩ pull-down resistor that is enabled by default. It can be disabled through programming.
BT_DEV_WAKE	L2	I/O	Bluetooth DEV_WAKE.
BT_HOST_WAKE	M3	I/O	Bluetooth HOST_WAKE.
Integrated Voltage Regulators			
SR_VDDBAT5V	A2	PWR	Supply to internal CBUCK regulator. Connect to V _{BAT} .
SR_VLX	B1	PWR	CBUCK switching regulator output. Refer to Table 42 for details of the inductor and capacitor required on this output.
LDO_VDD1P5	A3	PWR	LNLDO input. Connect to SR_VLX i.e. 1.35 V CBUCK switching regulator output.
LDO_VDDBAT5V	A5	PWR	Supply to internal BTLDO2P5 and LDO3P3 regulators. Connect to V _{BAT} .
WRF_XTAL_VDD1P35	H10	PWR	XTAL LDO input. Connect to SR_VLX i.e. 1.35V CBUCK switching regulator output.
WRF_XTAL_VDD1P2	H9	PWR	XTAL LDO output (1.2 V).
VOUT_LNLDO	B4	PWR	Output of LNLDO.
VOUT_CLDO	B3	PWR	Output of core LDO.
VOUT_BTLDO2P5	B5	PWR	Output of BT LDO.
VOUT_3P3	A4	PWR	LDO 3.3 V output.
VOUT_HLDO	B2	PWR	1.2 V output of the HLDO. Connect to the AVDD_BBPLL pad on the PCB to supply the baseband PLL
VOUT_MEMLPLDO	C4	PWR	0.9 V output of internal LDO
VDDC_MEM	F4	PWR	0.9 V rail for WLAN/BT SRAM etc. Connect to VOUT_MEMLPLDO pad on the PCB
Bluetooth Supplies			
BT_PAVDD2P5	N6	PWR	Bluetooth PA power supply. Connect to VOUT_BTLDO2P5 i.e. 2.5V output of BTLDO2P5.
BT_LNAVDD1P2	M7	PWR	Bluetooth LNA power supply. Connect to VOUT_LNLDO i.e. 1.2V output of LNLDO.
BT_IFVDD1P2	N4	PWR	Bluetooth IF block power supply. Connect to VOUT_LNLDO i.e. 1.2V output of LNLDO.
BT_PLLVDD1P2	N5	PWR	Bluetooth RF PLL power supply. Connect to VOUT_LNLDO i.e. 1.2V output of LNLDO.
WLAN Supplies			
WRF_SYNTN_VDD3P3	H8	PWR	Synthesizer supply. Connect to VOUT_3P3 i.e. 3.3 V output of LDO3P3.
WRF_PA_VDD3P3	N11	PWR	2.4 GHz and 5 GHz PA supply. Connect to VOUT_3P3 i.e. 3.3 V output of LDO3P3.
WRF_PMU_VDD1P35	J11	PWR	PMU supply. Connect to SR_VLX i.e. 1.35V CBUCK switching regulator output.
WRF_TXMIX_VDD	M9	PWR	Supply for the TX Mix. Connect to VOUT_3P3 i.e. 3.3 V output of LDO3P3.

Table 18. Signal Descriptions (Cont.)

Signal Name	WLBGA Ball	Type	Description
WRF_SYNTH_VDD1P2	J10	PWR	Supply for the synthesizer. Connect to WRF_XTAL_VDD1P2 i.e. 1.2V output of XTAL LDO.
WRF_AFE_VDD1P35	K10	PWR	Supply for the AFE. Connect to SR_VLX i.e. 1.35V CBUCK switching regulator output.
USB2_AVDD33	H2	PWR	Power Supply for shared USB2.0. When V_{BAT} is between 3.6V to 4.8V connect to VOUT_3P3 i.e. 3.3V output of LDO3P3. When V_{BAT} is 3.3V connect directly to V_{BAT} .
WLAN STRAPS			
GPIO_15 / STRAP_2	G7	I	USB_DISABLE
GPIO_14 / STRAP_1	F6	I	USBHUB_BYPASS
GPIO_13 / STRAP_0/ STRAP_XTAL_SEL_1	F7	I	SDIO_PADVDDIO sel, XTAL sel in USB mode
Miscellaneous Supplies			
VDDC	C8, E2, F8, J5, J7	PWR	1.2V core supply for the WLAN. This should be connected to VOUT_CLDO i.e. the 1.2V output of the internal CLDO.
VDDIO	D6	PWR	1.8V/3.3V supply for SDIO pads and WLAN. The same supply connected to this pin must be connected to the BT_VDDO pin also.
BT_VDDC	M4, J4, L1	PWR	1.2V core supply for BT. This should be connected to the VOUT_CLDO pin i.e. the 1.2V output of the internal CLDO.
BT_VDDO	G4	PWR	1.8V/3.3V supply for BT. The same supply connected to this pin must be connected to the VDDIO pin also.
VDDIO_RF	G8	PWR	IO supply for the RF switch control pads. This should be connected to the VOUT_3P3 pin i.e. the 3.3V output from the internal LDO3P3.
AVDD_BBPLL	E9	PWR	1.2V supply for the baseband PLL. This should be connected to the VOUT_HLDO pin i.e. the 1.2V output from the internal HLDO.
Ground			
WRF_VCO_GND	J8	GND	VCO/LOGEN ground.
WRF_AFE_GND	L9	GND	AFE ground.
WRF_XTAL_GND1P2	G10	GND	XTAL ground.
WRF_RX2G_GND	M8	GND	RX 2 GHz ground.
WRF_RX5G_GND	K11	GND	RX 5 GHz ground.
WRF_PA_GND3P3	M10	GND	PA ground.
WRF_GENERAL_GND	K9	GND	General ground.
WRF_GENERAL2_GND	L10	GND	General ground.
WRF_SYNTH_GND	J9	GND	Ground.
VSSC (Previously BT_GPIO_4)	H5	GND	Must be shorted to Ground on PCB. Usage of this GPIO will lead to higher current consumption due to leakage in lower power modes.
VSSC	C5, F5, F9, J3, K7	GND	Core ground for WLAN and BT.
SR_PVSS	A1	GND	Power ground.
PMU_AVSS	C2	GND	Quiet ground.
BT_LNAVSS	M6	GND	Bluetooth LNA ground.
BT_IFVSS	L5	GND	Bluetooth IF block ground.
BT_PLLVSS	M5	GND	Bluetooth PLL ground.
AVSS_BBPLL	E10	GND	Baseband PLL ground.

Table 18. Signal Descriptions (Cont.)

Signal Name	WLBGA Ball	Type	Description
VSSC	B10, C9, C10, D7	GND	General ground.
USB2_AVSS	G2	GND	Ground for shared USB2.0.
Depopulated Pins			
A11, C1, D5, D11, E6, F11, G5,G6, H3, H6, H7, J6, K2, K6, and N10	-	-	-

13.4 WLAN GPIO Signals and Strapping Options

This section describes WLAN GPIO signals and strapping options. The pins are sampled at POR to determine the various operating modes. Sampling occurs a few milliseconds (~3.5ms) after an internal POR or deassertion of the external POR. After the POR, each pin assumes the GPIO or alternative function specified in the signal descriptions table. Each strapping option pin has an internal pull-up (PU) or pull-down (PD) resistor that determines the default mode. To change the mode, connect an external PU resistor to VDDIO or a PD resistor to GND, using a 10 kΩ resistor or less.

Note: Refer to the reference board schematics for more information.

Table 19. Strap Pins

Pad/Ball	Default pull	Functionality
GPIO_15 / STRAP_2	1	USB_DISABLE
GPIO_14 / STRAP_1	1	USBHUB_BYPASS
GPIO_13 / STRAP_0/STRAP_XTAL_SEL_0	1	SDIO_PADVDDIO, sel, XTAL sel in USB mode

Notes:

- Strapping options are defined such a way that defaults are having internal PULL UPs, so that it is easy to configure the strap value in opposite manner on board (it is simple to short to GND on board ,there is no need for a pull down resistor).
- SDIO is mode is available by default in all the below combinations. . In "SDIO only" mode OTP for SDIO is available. OTP for SDIO CIS TUPLES will not be available in other modes. Need to use default CIS tuples for other modes.

Table 20. Strapping Options

USB_DISABLE STRAP_2 GPIO_15	USBHUB_BYPASS STRAP_1 GPIO_14	SDIO_PADVDDIO STRAP_0 GPIO_13	Mode Selected	SDIO OTP present
0	0	Refer XTAL selection table below	USB	0
1	1	0 = SDIO is 3.3V 1 = SDIO is 1.8V	Reserved for Future Usage	0
1	0		SDIO only	1

13.5 XTAL Selection Table for WLBGA in USB mode

Note: In USB mode, SDIO pads would come up in 3.3V mode only. There is no option for SDIO pads to powerup with 1.8V mode. In non-USB mode (SDIO), SDIO pads supports both 1.8v and 3.3v signaling.

Table 21. XTAL selection with WLBGA package

GPIO_13/STRAP_0/STRAP_XTAL_SEL0	XTAL value (MHz)
0	37.4

13.5.1 Multiplexed WLAN GPIO signals

Table 22. Multiplexed WLAN GPIO signals

Pin/Function Sel	HWDecided/PowerONDefault	SameAsPin Name	GPIO-0	FAST_UART/ GPIO_1	GCI-0	GCI-1	DBG_UART	SFLASH	SPRO M	MIM
GPIO_0	TRISTATE_IND	WL_HOST_WAKE/ GPIO_0	GPIO_8		GCI_GPIO_0	GCI_GPIO_11			8	9
GPIO_1	TRISTATE_IND	WL_DEV_WAKE/ GPIO_1	GPIO_9		GCI_GPIO_1	GCI_GPIO_12				RF_L_L_
GPIO_2	JTAG_SEL?TCK: TRISTATE_IND	GPIO_2	GPIO_10	FAST_UART_RX	GCI_GPIO_2	GCI_GPIO_13				TCK
GPIO_3	JTAG_SEL?TMS: TRISTATE_IND	GPIO_3	GPIO_11	FAST_UART_TX	GCI_GPIO_3	GCI_GPIO_14				TMS
GPIO_4	JTAG_SEL?TDI: TRISTATE_IND	GPIO_4	GPIO_12	FAST_UART_CT S_IN	GCI_GPIO_4	GCI_GPIO_15	UART_DBG_RX			TDI
GPIO_5	JTAG_SEL?TDO: TRISTATE_IND	GPIO_5	GPIO_13	FAST_UART_RT S_OUT	GCI_GPIO_0	GCI_GPIO_5	UART_DBG_TX			TDO
GPIO_6	JTAG_SEL?TRST L:TRISTATE_IN D	GPIO_6/ USB_VBUS	GPIO_14		GCI_GPIO_1	GCI_GPIO_6				TRS
GPIO_13	TRISTATE_IND	GPIO_13	GPIO_5		GCI_GPIO_3	GCI_GPIO_13				
GPIO_14	TRISTATE_IND	GPIO_14	GPIO_6		GCI_GPIO_4	GCI_GPIO_14				
GPIO_15	TRISTATE_IND	GPIO_15	GPIO_7			GCI_GPIO_15				
SDIO_CLK	TEST_MODE? TEST_SDIO_CLK	SDIO_CLK								SDIO_CLK
SDIO_CMD	TEST_MODE? TEST_SDIO_CMD	SDIO_CMD	GPIO_11		GCI_GPIO_0			SFLASH_CS#		SDIO_CMD
SDIO_DATA_0	TEST_MODE? TEST_SDIO_DATA_0	SDIO_D0	GPIO_12		GCI_GPIO_1			SFLASH_CLK		SDIO_D0

	HWDecided/ PowerONDefault	SameAsPin Name	GPIO-0	FAST_UART/ GPIO_1	GCI-0	GCI-1	DBG_UART	SFLASH	SPRO M	MI
SDIO_DATA _1	TEST_MODE? TEST_SDIO_DAT A_1: SDIO_EN?SDIO DATA_1:TRISTAT E_IND	SDIO_D1	GPIO_13		GCI_GPIO_2			SFLASH _MISO		SDIC D1
SDIO_DATA _2	TEST_MODE? TEST_SDIO_DAT A_2: SDIO_EN?SDIO DATA_2:TRISTAT E_IND	SDIO_D2	GPIO_14		GCI_GPIO_3					SDIC D2
SDIO_DATA _3	TEST_MODE? TEST_SDIO_DAT A_3: SDIO_EN?SDIO DATA_3:TRISTA TE_IND	SDIO_D3	GPIO_15		GCI_GPIO_4			SFLASH _MOSI		SDIC D3
RF_SW_CT RL_0	RF_SW_CTRL_0	RF_SW_CT RL_0								
RF_SW_CT RL_1	RF_SW_CTRL_1	RF_SW_CT RL_1								
RF_SW_CT RL_2	RF_SW_CTRL_2	RF_SW_CT RL_2								
RF_SW_CT RL_3	RF_SW_CTRL_3	RF_SW_CT RL_3	GPIO_8	GPIO_0		GCI_GPIO_8				PALD
RF_SW_CT RL_4	RF_SW_CTRL_4	RF_SW_CT RL_4	GPIO_9	GPIO_1		GCI_GPIO_9				PALD
RF_SW_CT RL_5	RF_SW_CTRL_5	RF_SW_CT RL_5	GPIO_10	GPIO_2		GCI_GPIO_10	UART_DBG_RX			
RF_SW_CT RL_6	RF_SW_CTRL_6	RF_SW_CT RL_6	GPIO_11	GPIO_3		GCI_GPIO_11	UART_DBG_TX			

13.6 I/O States

The following notations are used in Table 23.

- I: Input signal
- O: Output signal
- I/O: Input/Output signal
- PU = Pulled up (39.58kOhm resistance¹)
- PD = Pulled down (44.57kOhm resistance¹)
- NoPull = Neither pulled up nor pulled down

Table 23. I/O States

Name	I/O	Keeper ¹	Active Mode	Low Power State/ Sleep (All Power Present)	Power-down ² (BT_REG_ON and WL_REG_ON Held Low)	Out-of-Reset: Before SW Download (BT_REG_ON High; WL_REG_ON High)	(WL_REG_ON, BT_REG_ON, VDDIOs)
WL_REG_ON	I	N	Input; PD (pull-down can be disabled)	Input; PD (pull-down can be disabled)	Input; PD (of 200K)	Input; PD (of 200K)	Input; F
BT_REG_ON	I	N	Input; PD (pull down can be disabled)	Input; PD (pull down can be disabled)	Input; PD (of 200K)	Input; PD (of 200K)	Input; F
CLK_REQ	O	Y	Open drain or push-pull (programmable). Active high.	Open drain or push-pull (programmable). Active high	High-Z, NoPull	Open drain. Active high	PD
BT_HOST_WAKE	O	Y	Input/Output; PU, PD, NoPull (programmable)	Input/Output; PU, PD, NoPull (programmable)	High-Z, NoPull	Input, No Pull	High-Z
BT_DEV_WAKE	I	Y	Input/Output; PU, PD, NoPull (programmable)	Input; PU, PD, NoPull (programmable)	High-Z, NoPull	Input, PD	High-Z
BT_GPIO_2	I/O	Y	Input/Output; PU, PD, NoPull (programmable)	Input/Output; PU, PD, NoPull (programmable)	High-Z, NoPull	Input, PD	High-Z
BT_GPIO_3	I/O	Y	Input/Output; PU, PD, NoPull (programmable)	Input/Output; PU, PD, NoPull (programmable)	High-Z, NoPull	Input, PD	PD
BT_GPIO_4 (Do not Use) ⁵	I/O	Y	Input/Output; PU, PD, NoPull (programmable)	Input/Output; PU, PD, NoPull (programmable)	High-Z, NoPull	Input, PU ⁶	High-Z

1. Typical value from simulation data with VDDO=3.3V +/- 10%

Table 23. I/O States (Cont.)

Name	I/O	Keeper ₁	Active Mode	Low Power State/ Sleep (All Power Present)	Power-down ² (BT_REG_ON and WL_REG_ON Held Low)	Out-of-Reset: Before SW Download (BT_REG_ON High; WL_REG_ON High)	(WL_REG_ON BT_REG_ON High; VDDIOs)
BT_GPIO_5	I/O	Y	Input/Output; PU, PD, NoPull (programmable)	Input/Output; PU, PD, NoPull (programmable)	High-Z, NoPull	Input, PU	High-Z
BT_UART_CTS_N	I	Y	Input; NoPull	Input; NoPull	High-Z, NoPull	Input; PU	High-Z
BT_UART_RTS_N	O	Y	Output; NoPull	Output; NoPull	High-Z, NoPull	Input; PU	High-Z
BT_UART_RXD	I	Y	Input; PU	Input; NoPull	High-Z, NoPull	Input; PU	High-Z
BT_UART_TXD	O	Y	Output; NoPull	Output; NoPull	High-Z, NoPull	Input; PU	High-Z
SDIO_DATA[0:3]	I/O	N	Input/Output; PU (SDIO Mode)	Input; PU (SDIO Mode)	High-Z, NoPull	Input; PU (SDIO Mode)	Input; F
SDIO_CMD	I/O	N	Input/Output; PU (SDIO Mode)	Input; PU (SDIO Mode)	High-Z, NoPull	Input; PU (SDIO Mode)	Input; F
SDIO_CLK	I	N	Input; NoPull	Input; noPull	High-Z, NoPull	Input; noPull	High-Z
BT_PCM_CLK	I/O	Y	Input; NoPull ³	Input; NoPull ³	High-Z, NoPull	Input; PD	High-Z
BT_PCM_IN	I/O	Y	Input; NoPull ³	Input; NoPull ³	High-Z, NoPull	Input; PD	High-Z
BT_PCM_OUT	I/O	Y	Input; NoPull ³	Input; NoPull ³	High-Z, NoPull	Input; PD	PD
BT_PCM_SYNC	I/O	Y	Input; NoPull ³	Input; NoPull ³	High-Z, NoPull	Input; PD	Input; F
GPIO_0	I/O	Y	Input/Output; PU, PD, NoPull (programmable [Default: PD])	Input/Output; PU, PD, NoPull (programmable [Default: PD])	High-Z, NoPull	Input; PD	Input; F
GPIO_1	I/O	Y	Input/Output; PU, PD, NoPull (programmable [Default: NoPull])	Input/Output; PU, PD, NoPull (programmable [Default: NoPull])	High-Z, NoPull	Input; NoPull	Input; N
GPIO_2	I/O	Y	Input/Output; PU, PD, NoPull (programmable [Default: NoPull])	Input/Output; PU, PD, NoPull (programmable [Default: NoPull])	High-Z, NoPull	Input; NoPull	Input; N
GPIO_3	I/O	Y	Input/Output; PU, PD, NoPull (programmable [Default: PD])	Input/Output; PU, PD, NoPull (programmable [Default: PD])	High-Z, NoPull	Input; PD	Input; F

Table 23. I/O States (Cont.)

Name	I/O	Keeper ¹	Active Mode	Low Power State/ Sleep (All Power Present)	Power-down ² (BT_REG_ON and WL_REG_ON Held Low)	Out-of-Reset; Before SW Download (BT_REG_ON High; WL_REG_ON High)	(WL_REG_ON BT_REG_ON High; VDDIOs)
GPIO_4	I/O	Y	Input/Output; PU, PD, NoPull (programmable [Default: NoPull])	Input/Output; PU, PD, NoPull (programmable [Default: NoPull])	High-Z, NoPull	Input; NoPull	Input; NoPull
GPIO_5	I/O	Y	Input/Output; PU, PD, NoPull (programmable [Default: PD])	Input/Output; PU, PD, NoPull (programmable [Default: PD])	High-Z, NoPull	Input; PD	Input; F
GPIO_6	I/O	Y	Input/Output; PU, PD, NoPull (programmable [Default: NoPull])	Input/Output; PU, PD, NoPull (programmable [Default: NoPull])	High-Z, NoPull	Input; NoPull	Input; NoPull
STRAP_0	I/O	Y	Input/Output; PU, PD, NoPull (programmable [Default: NoPull])	Input/Output; PU, PD, NoPull (programmable [Default: NoPull])	High-Z, NoPull	Input; NoPull	Input; NoPull
STRAP_1	I/O	Y	Input/Output; PU, PD, NoPull (programmable [Default: PD]) ⁴	Input/Output; PU, PD, NoPull (programmable [Default: PD]) ⁴	High-Z, NoPull	Input; PD ⁴	Input; F
STRAP_2	I/O	Y	Input/Output; PU, PD, NoPull (programmable [Default: PD])	Input/Output; PU, PD, NoPull (programmable [Default: PD])	High-Z, NoPull	Input; PD	Input; F
RF_SW_CTRL[0:6]	I/O	Y	Output; NoPull	Output; NoPull	High-Z	Output; NoPull	Output;

1. Keeper column: N = pad has no keeper. Y = pad has a keeper. Keeper is always active except in power-down state. If there is no keeper, and it is an input and there is NoPull prevent leakage due to floating pad (SDIO_CLK, for example).
2. In the power-down state (xx_REG_ON=0): High-Z; NoPull => the pad is disabled because power is not supplied.
3. Depending on whether the PCM interface is enabled and the configuration of PCM is in master or slave mode, it can be either Output or input.
4. NoPull when in SDIO mode.
5. BT_GPIO_4 must not be used. This pad must be shorted to ground i.e. must be VSSC on the PCB
6. When BT_GPIO_4 is connected to ground (as recommended in this datasheet) there will be a small leakage current momentarily when the chip exits reset with BT_REG_ON pin pull up on this pin. This leakage stops post BT firmware download because the BT firmware disables the pull up and enables a pull down on BT_GPIO_4

14. DC Characteristics

Note: Values in this data sheet are design goals and are subject to change based on the results of device characterization.

14.1 Absolute Maximum Ratings

Caution! The absolute maximum ratings in [Table 24](#) indicate levels where permanent damage to the device can occur, even if these limits are exceeded for only a brief duration. Functional operation is not guaranteed under these conditions. Operation at absolute maximum conditions for extended periods can adversely affect long-term reliability of the device.

Table 24. Absolute Maximum Ratings

Rating	Symbol	Value	Unit
DC supply for the V _{BAT} supply	V _{BAT}	-0.5 to +5.5 ¹	V
DC supply voltage for digital I/O	VDDIO	-0.5 to 3.9	V
DC supply voltage for RF switch I/Os	VDDIO_RF	-0.5 to 3.9	V
DC input supply voltage for CLDO and LNLDO	-	-0.5 to 1.575	V
DC supply voltage for RF analog	VDDRF	-0.5 to 1.32	V
DC supply voltage for core	VDDC	-0.5 to 1.32	V
Maximum undershoot voltage for I/O ²	V _{undershoot}	-0.5	V
Maximum overshoot voltage for I/O ²	V _{overshoot}	VDDIO + 0.5	V
Maximum junction temperature	T _j	125	°C

1. Non-switching voltages of up to 5.5V can be tolerated for up to 10 seconds, cumulative duration over the lifetime of the device.
2. Duration not to exceed 25% of the duty cycle.

14.2 Environmental Ratings

The environmental ratings are shown in [Table 25](#).

Table 25. Environmental Ratings

Characteristic	Value	Unit	Conditions/Comments
Ambient Temperature (T _A)	-20 to +70	°C	Functional operation
Storage Temperature	-40 to +125	°C	-
Relative Humidity	Less than 60	%	Storage
	Less than 85	%	Operation

14.3 Electrostatic Discharge Specifications

Extreme caution must be exercised to prevent electrostatic discharge (ESD) damage. Proper use of wrist and heel grounding straps to discharge static electricity is required when handling these devices. Always store unused material in its antistatic packaging.

Table 26. ESD Specifications

Pin Type	Symbol	Condition	Minimum ESD Rating	Unit
ESD: Handling Reference: NQY00083, Section 3.4, Group D9, Table B	ESD_HAND_HBM	Human body model contact discharge per JEDEC EID/JESD22-A114	2	kV
CDM	ESD_HAND_CDM	Charged device model contact discharge per JEDEC EIA/JESD22-C101	450	V

14.4 Recommended Operating Conditions and DC Characteristics

Caution! Functional operation is not guaranteed outside of the limits shown in Table 27. Operation outside these limits for extended periods can adversely affect long-term reliability of the device.

Note: For DC absolute maximum rating (AMR), see Table 24.

Table 27. Recommended Operating Conditions and DC Characteristics

Parameter	Symbol	Value			Unit
		Min	Typ	Max	
DC supply voltage for V _{BAT}	V _{BAT}	3.2 ¹	3.6	4.8 ²	V
DC supply voltage for core	VDD	1.14	1.2	1.26	V
DC supply voltage for RF blocks in chip	VDDRF	1.14	1.2	1.26	V
DC supply voltage for digital I/O	VDDIO	1.62	1.8/3.3	3.63	V
DC supply voltage for RF switch I/Os	VDDIO_RF	3.13	3.3	3.46	V
External TSSI input	TSSI	0.15	–	0.95	V
Internal POR threshold	V _{th_POR}	0.4	–	0.7	V
Other Digital I/O Pins					
For VDDIO = 1.8V:					
Input high voltage	V _{IH}	0.65 × VDDIO	–	–	V
Input low voltage	V _{IL}	–	–	0.35 × VDDIO	V
Output high voltage @ 2 mA	V _{OH}	VDDIO – 0.45	–	–	V
Output low voltage @ 2 mA	V _{OL}	–	–	0.45	V
For VDDIO = 3.3V:					
Input high voltage	V _{IH}	2.00	–	–	V
Input low voltage	V _{IL}	–	–	0.80	V
Output high voltage @ 2 mA	V _{OH}	VDDIO – 0.4	–	–	V
Output low Voltage @ 2 mA	V _{OL}	–	–	0.40	V
RF Switch Control Output Pins³					
For VDDIO_RF = 3.3V:					
Output high voltage @ 2 mA	V _{OH}	VDDIO – 0.4	–	–	V
Output low voltage @ 2 mA	V _{OL}	–	–	0.40	V
Output capacitance	C _{OUT}	–	–	5	pF

1. The CYW4373 is functional across this range of voltages. Optimal RF performance specified in the data sheet, however, is guaranteed only for 3.6V < V_{BAT} < 4.8V.
2. The maximum continuous voltage is 4.8V.
3. Programmable 2 mA to 16 mA drive strength. Default is 10 mA.

15. Bluetooth RF Specifications

Note: Values in this data sheet are design goals and are subject to change based on device characterization results.

Unless otherwise stated, limit values apply for the conditions specified in [Table 25 “Environmental Ratings”](#) and [Table 27 “Recommended Operating Conditions and DC Characteristics”](#). Typical values apply for the following conditions:

- $V_{BAT} = 3.6V$
- Ambient temperature +25°C

Figure 33. Port Locations for Bluetooth Testing

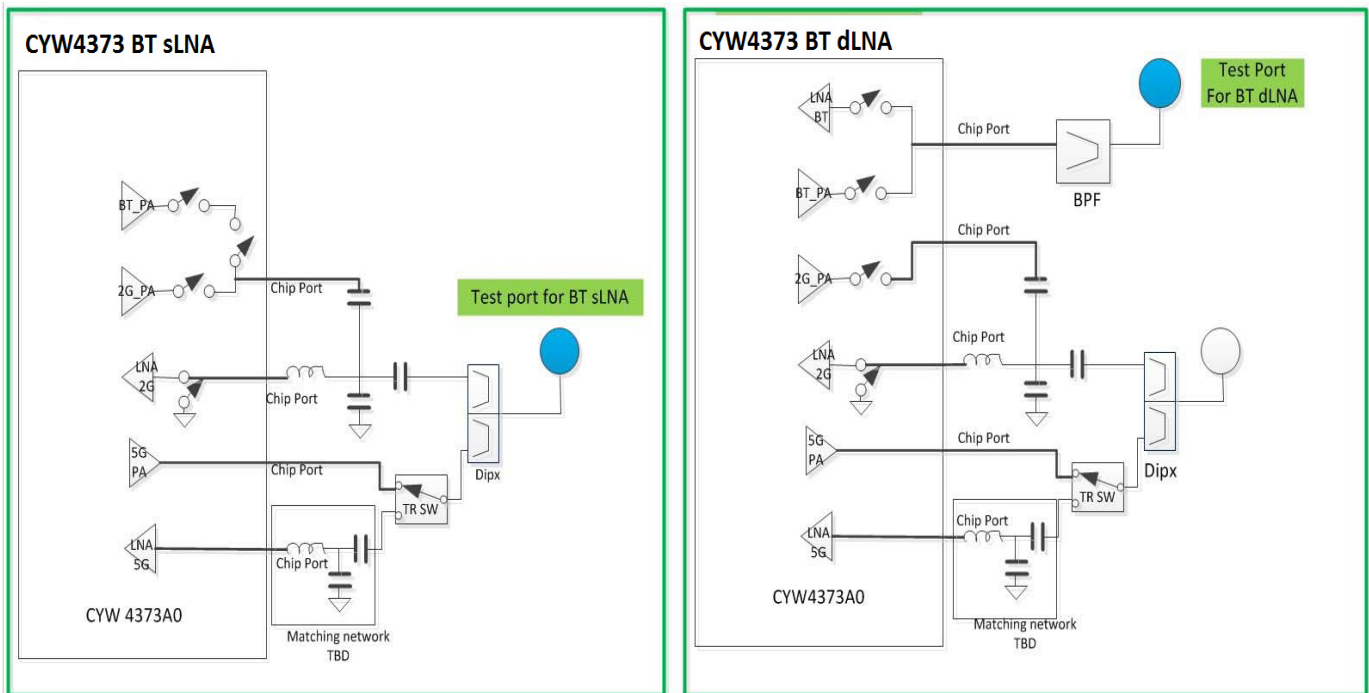

Notes:

- All Bluetooth specifications are measured at the chip port, unless otherwise defined.
- The specifications in [Table 28](#) are measured at the chip port input, unless otherwise defined.

Table 28. Bluetooth Receiver RF Specifications

Parameter	Conditions	Min	Typ	Max	Unit
General					
Frequency range	–	2402	–	2480	MHz
RX sensitivity ¹	GFSK, 0.1% BER, 1 Mbps	–	–93.2	–	dBm
	$\pi/4$ -DQPSK, 0.01% BER, 2 Mbps	–	–95.2	–	dBm
	8-DPSK, 0.01% BER, 3 Mbps	–	–89.2	–	dBm
Input IP3	–	–16	–	–	dBm
Maximum input at RF port	–	–	–	–20	dBm
RX LO Leakage					
2.4 GHz band	–	–	–	–90	dBm
Interference Performance²					
C/I co-channel	GFSK, 0.1% BER	–	–	11	dB
C/I 1 MHz adjacent channel	GFSK, 0.1% BER	–	–	0	dB
C/I 2 MHz adjacent channel	GFSK, 0.1% BER	–	–	–30	dB
C/I \geq 3 MHz adjacent channel	GFSK, 0.1% BER	–	–	–40	dB
C/I image channel	GFSK, 0.1% BER	–	–	–9	dB
C/I 1-MHz adjacent to image channel	GFSK, 0.1% BER	–	–	–20	dB
C/I co-channel	$\pi/4$ -DQPSK, 0.1% BER	–	–	13	dB
C/I 1 MHz adjacent channel	$\pi/4$ -DQPSK, 0.1% BER	–	–	0	dB
C/I 2 MHz adjacent channel	$\pi/4$ -DQPSK, 0.1% BER	–	–	–30	dB
C/I \geq 3 MHz adjacent channel	$\pi/4$ -DQPSK, 0.1% BER	–	–	–40	dB
C/I image channel	$\pi/4$ -DQPSK, 0.1% BER	–	–	–7	dB
C/I 1 MHz adjacent to image channel	$\pi/4$ -DQPSK, 0.1% BER	–	–	–20	dB
C/I co-channel	8-DPSK, 0.1% BER	–	–	21	dB
C/I 1 MHz adjacent channel	8-DPSK, 0.1% BER	–	–	5	dB
C/I 2 MHz adjacent channel	8-DPSK, 0.1% BER	–	–	–25	dB
C/I \geq 3 MHz adjacent channel	8-DPSK, 0.1% BER	–	–	–33	dB
C/I Image channel	8-DPSK, 0.1% BER	–	–	0	dB
C/I 1 MHz adjacent to image channel	8-DPSK, 0.1% BER	–	–	–13	dB
Out-of-Band Blocking Performance (CW)					
30–2000 MHz	0.1% BER	–	–10	–	dBm
2000–2399 MHz	0.1% BER	–	–27	–	dBm
2498–3000 MHz	0.1% BER	–	–27	–	dBm
3000 MHz–12.75 GHz	0.1% BER	–	–10	–	dBm
Out-of-Band Blocking Performance, Modulated Interferer					
GFSK (1 Mbps)³					
698–716 MHz	WCDMA	–	–14	–	dBm
776–849 MHz	WCDMA	–	–14	–	dBm
824–849 MHz	GSM850	–	–14	–	dBm
824–849 MHz	WCDMA	–	–14	–	dBm
880–915 MHz	E-GSM	–	–13	–	dBm

Table 28. Bluetooth Receiver RF Specifications (Cont.)

Parameter	Conditions	Min	Typ	Max	Unit
880–915 MHz	WCDMA	–	–13	–	dBm
1710–1785 MHz	GSM1800	–	–18	–	dBm
1710–1785 MHz	WCDMA	–	–17	–	dBm
1850–1910 MHz	GSM1900	–	–20	–	dBm
1850–1910 MHz	WCDMA	–	–19	–	dBm
1880–1920 MHz	TD-SCDMA	–	–20	–	dBm
1920–1980 MHz	WCDMA	–	–20	–	dBm
2010–2025 MHz	TD-SCDMA	–	–20	–	dBm
2500–2570 MHz	WCDMA	–	–23	–	dBm
2500–2570 MHz ⁴	Band 7	–	–25	–	dBm
2300–2400 MHz ⁵	Band 40	–	–35.2	–	dBm
2570–2620 MHz ⁶	Band 38	–	–21	–	dBm
2545–2575 MHz ⁷	XGP Band	–	–22	–	dBm
$\pi/4$-DPSK (2 Mbps)³					
698–716 MHz	WCDMA	–	–10	–	dBm
776–794 MHz	WCDMA	–	–10	–	dBm
824–849 MHz	GSM850	–	–11	–	dBm
824–849 MHz	WCDMA	–	–11	–	dBm
880–915 MHz	E-GSM	–	–10	–	dBm
880–915 MHz	WCDMA	–	–10	–	dBm
1710–1785 MHz	GSM1800	–	–16	–	dBm
1710–1785 MHz	WCDMA	–	–16	–	dBm
1850–1910 MHz	GSM1900	–	–17	–	dBm
1850–1910 MHz	WCDMA	–	–16	–	dBm
1880–1920 MHz	TD-SCDMA	–	–18	–	dBm
1920–1980 MHz	WCDMA	–	–17	–	dBm
2010–2025 MHz	TD-SCDMA	–	–19	–	dBm
2500–2570 MHz	WCDMA	–	–23	–	dBm
2500–2570 MHz ⁴	Band 7	–	–24.4	–	dBm
2300–2400 MHz ⁵	Band 40	–	–36.5	–	dBm
2570–2620 MHz ⁶	Band 38	–	–21	–	dBm
2545–2575 MHz ⁷	XGP Band	–	–22	–	dBm
8-DPSK (3 Mbps)³					
698-716 MHz	WCDMA	–	–13	–	dBm
776-794 MHz	WCDMA	–	–13	–	dBm
824-849 MHz	GSM850	–	–13	–	dBm
824-849 MHz	WCDMA	–	–14	–	dBm
880-915 MHz	E-GSM	–	–13	–	dBm
880-915 MHz	WCDMA	–	–13	–	dBm
1710-1785 MHz	GSM1800	–	–18	–	dBm

Table 28. Bluetooth Receiver RF Specifications (Cont.)

Parameter	Conditions	Min	Typ	Max	Unit
1710-1785 MHz	WCDMA	–	–17	–	dBm
1850-1910 MHz	GSM1900	–	–19	–	dBm
1850-1910 MHz	WCDMA	–	–19	–	dBm
1880-1920 MHz	TD-SCDMA	–	–19	–	dBm
1920-1980 MHz	WCDMA	–	–19	–	dBm
2010-2025 MHz	TD-SCDMA	–	–20	–	dBm
2500-2570 MHz	WCDMA	–	–23	–	dBm
2500–2570 MHz ⁴	Band 7	–	–24.7	–	dBm
2300–2400 MHz ⁵	Band 40	–	–36.7	–	dBm
2570–2620 MHz ⁶	Band 38	–	–21	–	dBm
2545–2575 MHz ⁷	XGP Band	–	–22	–	dBm
Spurious Emissions					
30 MHz–1 GHz		–	–95	–62	dBm
1–12.75 GHz		–	–70	–47	dBm
851–894 MHz		–	–147	–	dBm/Hz
925–960 MHz		–	–147	–	dBm/Hz
1805–1880 MHz		–	–147	–	dBm/Hz
1930–1990 MHz		–	–147	–	dBm/Hz
2110–2170 MHz		–	–147	–	dBm/Hz

1. Dirty TX is OFF.
2. The maximum value represents the actual Bluetooth specification required for Bluetooth qualification as defined in the v5.0 specification.
3. 3 dB receiver desense.
4. 2560 MHz performance is used.
5. 2360 MHz performance is used.
6. 2580 MHz performance is used.
7. 2555 MHz performance is used.

Table 29. Bluetooth Transmitter RF Specifications

Parameter	Conditions	Min	Typ	Max	Unit
Note: The specifications in this table are measured at the Bluetooth chip port output, unless otherwise defined.					
General					
Frequency range		2402	–	2480	MHz
dLNA Basic rate (GFSK) TX power		–	13	–	dBm
dLNA QPSK TX Power		–	10	–	dBm
dLNA 8PSK TX Power		–	10	–	dBm
sLNA Basic rate (GFSK) TX power		–	11	–	
sLNA QPSK TX Power		–	7	–	
sLNA 8PSK TX Power		–	7	–	
Power control step		2	4	8	dB
Note: Output power is with TCA and TSSI enabled.					
GFSK In-Band Spurious Emissions					
–20 dBc BW	–	–	0.93	1	MHz
EDR In-Band Spurious Emissions					
1.0 MHz < M – N < 1.5 MHz	M – N = the frequency range for which the spurious emission is measured relative to the transmit center frequency.	–	–	–26	dBc
1.5 MHz < M – N < 2.5 MHz		–	–	–20	dBm
M – N ≥ 2.5 MHz ¹		–	–	–40	dBm
Out-of-Band Spurious Emissions					
30 MHz to 1 GHz	–	–	–	–36 ^{2, 3}	dBm
1 GHz to 12.75 GHz	–	–	–	–26 ^{4, 5, 6}	dBm
1.8 GHz to 1.9 GHz	–	–	–	–47	dBm
5.15 GHz to 5.3 GHz	–	–	–	–47	dBm
GPS Band Spurious Emissions					
Spurious emissions	–	–	–103	–	dBm
Out-of-Band Noise Floor⁶					
776–794 MHz	CDMA2000	–	–146	–	dBm/Hz
869–960 MHz	cdmaOne, GSM850	–	–146	–	dBm/Hz
925–960 MHz	E-GSM	–	–146	–	dBm/Hz
1570–1580 MHz	GPS	–	–146	–	dBm/Hz
1805–1880 MHz	GSM1800	–	–144	–	dBm/Hz
1930–1990 MHz	GSM1900, cdmaOne, WCDMA	–	–143	–	dBm/Hz
2110–2170 MHz	WCDMA	–	–137	–	dBm/Hz
2500–2570 MHz	Band 7	–	–130	–	dBm/Hz
2300–2400 MHz	Band 40	–	–130	–	dBm/Hz
2570–2620 MHz	Band 38	–	–132	–	dBm/Hz
2545–2575 MHz	XGP Band	–	–135	–	dBm/Hz

1. The typical number is measured at ± 3 MHz offset.
2. The maximum value represents the value required for Bluetooth qualification as defined in the v5.0 specification.
3. The spurious emissions during Idle mode are the same as specified in [Table 29](#).
4. Specified at the Bluetooth Antenna port.

5. Meets this specification using a front-end band-pass filter.
6. Transmitted power in cellular bands at the antenna port. See [Figure 33](#) for location of the port.

Table 30. Local Oscillator Performance

Parameter	Min ¹	Typ ¹	Max ¹	Unit
LO Performance				
Lock time	–	72	–	μs
Initial carrier frequency tolerance	–	±25	±75	kHz
Frequency Drift				
DH1 packet	–	±10	±25	kHz
DH3 packet	–	±10	±40	kHz
DH5 packet	–	±10	±40	kHz
Drift rate	–	8	20	kHz/50 μs
Frequency Deviation				
00001111 sequence in payload ²	140	155	175	kHz
10101010 sequence in payload ³	115	135	–	kHz
Channel spacing	–	0.95	–	MHz

1. Min, Typical and Max numbers are tested at 2402, 2441 and 2480MHz channels respectively
2. This pattern represents an average deviation in payload.
3. Pattern represents the maximum deviation in payload for 99.9% of all frequency deviations.

Table 31. BLE RF Specifications

Parameter	Conditions	Min	Typ	Max	Unit
Frequency range	–	2402	–	2480	MHz
RX sense ¹	GFSK, 0.1% BER, 1 Mbps	–	–96.2	–	dBm
TX power ²	–	–	9.5	–	dBm
Mod Char: delta F1 average	–	225	255	275	kHz
Mod Char: delta F2 max. ³	–	185	225	–	kHz
Mod Char: ratio	–	0.8	0.95	–	

1. Dirty TX is Off.
2. The BLE TX power cannot exceed 10 dBm EIRP specification limit. The front-end losses and antenna gain/loss must be factored in so as not to exceed the limit.
3. At least 99.9% of all delta F2 max. frequency values recorded over 10 packets must be greater than 185 kHz.

16. WLAN RF Specifications

16.1 Introduction

The CYW4373 includes an integrated dual-band direct conversion radio that supports the 2.4 GHz and the 5 GHz bands. This section describes the RF characteristics of the 2.4 GHz and 5 GHz radio.

Note: Values in this section of the data sheet are design goals and are subject to change based on device characterization results.

Unless otherwise stated, limit values apply for the conditions specified in [Table 25 “Environmental Ratings”](#) and [Table 27 “Recommended Operating Conditions and DC Characteristics”](#). Typical values apply for the following conditions:

- $V_{BAT} = 3.6\text{ V}$
- Ambient temperature $+25^{\circ}\text{C}$

Figure 34. Port Locations for WLAN Testing

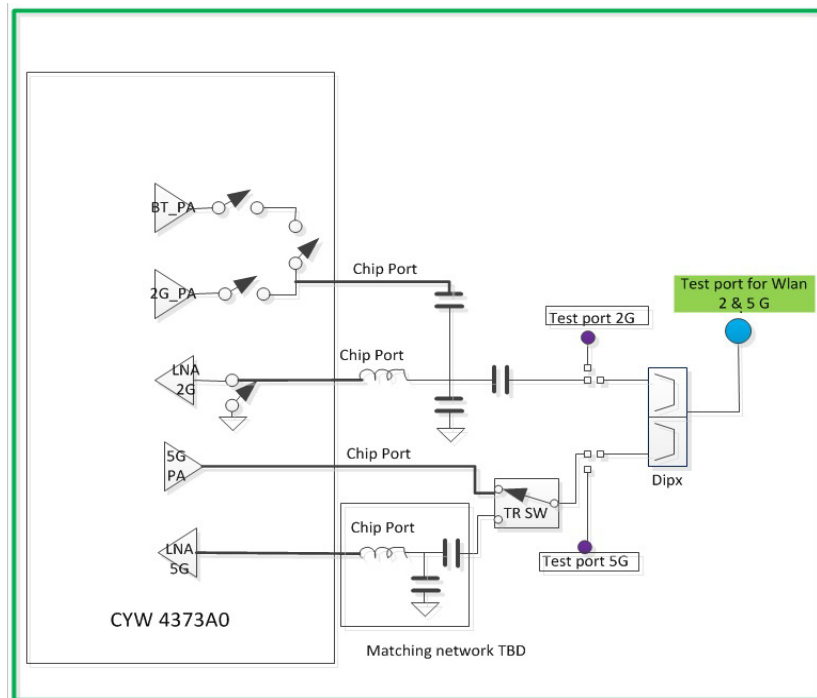

Note: Unless otherwise defined, all WLAN specifications are provided at the chip port.

16.2 WLAN 2.4 GHz Receiver Performance Specifications

Note: The specifications shown in the following table are provided at the chip port, unless otherwise defined.

Table 32. WLAN 2.4 GHz Receiver Performance Specifications

Parameter	Condition/Notes	Min	Typ	Max	Unit
Frequency range	–	2400	–	2500	MHz
RX sensitivity IEEE 802.11b (8% PER for 1024 octet PSDU)	1 Mbps DSSS	–94.2	–98.8	–	dBm
	2 Mbps DSSS	–	–96.6	–	dBm
	5.5 Mbps DSSS	–	–94.5	–	dBm
	11 Mbps DSSS	–88.5	–90.0	–	dBm
RX sensitivity IEEE 802.11g (10% PER for 1024 octet PSDU)	6 Mbps OFDM	–93.1	–94.5	–	dBm
	9 Mbps OFDM	–92.0	–93.0	–	dBm
	12 Mbps OFDM	–	–92.9	–	dBm
	18 Mbps OFDM	–89.0	–90.1	–	dBm
	24 Mbps OFDM	–	–87.2	–	dBm
	36 Mbps OFDM	–82.0	–83.2	–	dBm
	48 Mbps OFDM	–	–79.3	–	dBm
	54 Mbps OFDM	–76.1	–77.4	–	dBm
RX sensitivity IEEE 802.11n 20 MHz channel spacing (10% PER for 4096 octet PSDU) defined for default parameters: 800ns GI, and non-STBC ¹	20 MHz channel spacing for all MCS rates				
	MCS0	–93.2	–94.4	–	dBm
	MCS1	–	–93.5	–	dBm
	MCS2	–89.3	–90.7	–	dBm
	MCS3	–	–88.2	–	dBm
	MCS4	–83.1	–84.0	–	dBm
	MCS5	–	–80.3	–	dBm
	MCS6	–	–79.0	–	dBm
	MCS7	–75.2	–76.6	–	dBm
RX sensitivity IEEE 802.11n 40 MHz channel spacing (10% PER for 4096 octet PSDU) defined for default parameters: 800ns GI, and non-STBC ¹	40 MHz channel spacing for all MCS rates				
	MCS0	–90.6	–92.4	–	dBm
	MCS1	–	–91.1	–	dBm
	MCS2	–86.1	–88.2	–	dBm
	MCS3	–	–85.5	–	dBm
	MCS4	–80.6	–82.0	–	dBm
	MCS5	–	–77.9	–	dBm
	MCS6	–	–76.3	–	dBm
	MCS7	–73.1	–74.4	–	dBm

Table 32. WLAN 2.4 GHz Receiver Performance Specifications (Cont.)

Parameter	Condition/Notes	Min	Typ	Max	Unit
Blocking level for 3 dB RX sensitivity degradation (without external filtering) ²	776–794 MHz (CDMA2000):				
	Blocker frequency = 794 MHz	–	–19.2	–	dBm
	824–849 MHz³ (cdmaOne):				
	Blocker frequency = 849 MHz	–	–21.3	–	dBm
	824–849 MHz (GSM850):				
	Blocker frequency = 849 MHz	–	–17.3	–	dBm
	880–915 MHz (E-GSM):				
	Blocker frequency = 915 MHz	–	–18.5	–	dBm
	1710–1785 MHz (GSM1800):				
	Blocker frequency = 1785 MHz	–	–21.0	–	dBm
	1850–1910 MHz (GSM1900):				
	Blocker frequency = 1910 MHz	–	–20.7	–	dBm
	1850–1910 MHz (cdmaOne):				
	Blocker frequency = 1910 MHz	–	–21.3	–	dBm
	1850–1910 MHz (WCDMA):				
	Blocker frequency = 1910 MHz	–	–21.3	–	dBm
	1920–1980 MHz (WCDMA):				
	Blocker frequency = 1980 MHz	–	–22.1	–	dBm
	2300–2400 MHz (LTE band 40)				
	Blocker frequency = 2300 MHz	–	–27.8	–	dBm
Blocker frequency = 2365 MHz	–	–26.6	–	dBm	
2500–2570 MHz (LTE band 7):					
Blocker frequency = 2505 MHz	–	–25.4	–	dBm	
Blocker frequency = 2565 MHz	–	–27.6	–	dBm	
2570–2620 MHz (LTE band 38):					
Blocker frequency = 2575 MHz	–	–26.5	–	dBm	
2545–2575 MHz (XGP Band):					
Blocker frequency = 2550 MHz	–	–27.1	–	dBm	
In-band static CW jammer immunity (fc – 8 MHz < fcw < + 8 MHz)	RX PER < 1%, 54 Mbps OFDM, 1000 octet PSDU for: (RxSens + 23 dB < Rxlevel < max. input level)	–	–80	–	dBm
Input In-Band IP3	Maximum LNA gain	–	–9	–	dBm
	Minimum LNA gain	–	3	–	dBm
Maximum Receive Level @ 2.4 GHz	@ 1, 2 Mbps (8% PER, 1024 octets)	–3.5	–	–	dBm
	@ 5.5, 11 Mbps (8% PER, 1024 octets)	–9.5	–	–	dBm
	@ 6–54 Mbps (10% PER, 1024 octets)	–9.5	–	–	dBm
	@ MCS0–MCS7 rates (10% PER, 4096 octets)	–9.5	–	–	dBm

Table 32. WLAN 2.4 GHz Receiver Performance Specifications (Cont.)

Parameter	Condition/Notes	Min	Typ	Max	Unit
Adjacent channel rejection-DSSS (Difference between interfering and desired signal at 8% PER for 1024 octet PSDU with desired signal level as specified in Condition/Notes)	Desired and interfering signal 30 MHz apart				
	1 Mbps DSSS -74 dBm	35	>44	-	dB
	2 Mbps DSSS -74 dBm	35	-	-	dB
	Desired and interfering signal 25 MHz apart				
	5.5 Mbps DSSS -70 dBm	35	-	-	dB
	11 Mbps DSSS -70 dBm	35	>44	-	dB
Adjacent channel rejection-OFDM (Difference between interfering and desired signal (25 MHz apart) at 10% PER for 1024 octet PSDU with desired signal level as specified in Condition/Notes)	6 Mbps OFDM -79 dBm	16	38.0	-	dB
	9 Mbps OFDM -78 dBm	15	36.0	-	dB
	12 Mbps OFDM -76 dBm	13	-	-	dB
	18 Mbps OFDM -74 dBm	11	32.4	-	dB
	24 Mbps OFDM -71 dBm	8	-	-	dB
	36 Mbps OFDM -67 dBm	4	25.8	-	dB
	48 Mbps OFDM -63 dBm	0	-	-	dB
	54 Mbps OFDM -62 dBm	-1	20.4	-	dB
Adjacent channel rejection MCS0–MCS7 (Difference between interfering and desired signal (25 MHz apart) at 10% PER for 4096 octet PSDU with desired signal level as specified in Condition/Notes)	MCS0 -79 dBm	16	33.3	-	dB
	MCS1 -76 dBm	13	-	-	dB
	MCS2 -74 dBm	11	27.0	-	dB
	MCS3 -71 dBm	8	-	-	dB
	MCS4 -67 dBm	4	21.7	-	dB
	MCS5 -63 dBm	0	-	-	dB
	MCS6 -62 dBm	-1	-	-	dB
	MCS7 -61 dBm	-2	13.7	-	dB
Maximum receiver gain	-	66	70	72	dB
Gain control step	-	-	3.0	-	dB
RSSI accuracy ⁴	Range -90 dBm to -30 dBm	-5	-	5	dB
	Range above -30 dBm	-8	-	8	dB
Return loss	Z ₀ = 50Ω, across the dynamic range	-	8	-	dB
Receiver cascaded noise figure	At maximum gain	-	3.5	-	dB

1. Sensitivity degradations for alternate settings in MCS modes. SGI: 2 dB drop.
2. The cellular standard listed for each band indicates the type of modulation used to generate the interfering signal in that band for the purpose of this test. It is not intended to indicate any specific usage of each band in any specific country.
3. The blocking levels are valid for channels 1 to 11. (For higher channels, the performance may be lower due to third harmonic signals (3 × 824 MHz) falling within band.)
4. The minimum and maximum values shown have a 95% confidence level.

16.3 WLAN 2.4 GHz Transmitter Performance Specifications

Note: Unless otherwise noted, the values shown in the following table are provided at the WLAN chip port output.

Table 33. WLAN 2.4 GHz Transmitter Performance Specifications

Parameter	Condition/Notes	Min	Typ	Max	Unit	
Frequency range	–	2400	–	2500	MHz	
Transmitted power in cellular and bands (at +21 dBm, 100% duty cycle, 1 Mbps CCK) ¹	776-794 MHz (CDMA2000)	–	–164	–	dBm/Hz	
	869-960 MHz (cdmaOne, GSM850)	–	–163	–	dBm/Hz	
	1450-1495 (DAB)	–	–153.6	–	dBm/Hz	
	1570-1580 MHz (GPS)	–	–151.2	–	dBm/Hz	
	1592-1610 MHz (GLONASS)	–	–147.0	–	dBm/Hz	
	1710-1800 (DSC-1800-Uplink)	–	–145	–	dBm/Hz	
	1805-1880 MHz (GSM 1800)	–	–139	–	dBm/Hz	
	1850-1910 MHz (GSM 1900)	–	–139	–	dBm/Hz	
	1910-1930 MHz (TDSCDMA,LTE)	–	–140	–	dBm/Hz	
	1930-1990 MHz (GSM1900, cdmaOne, WCDMA)	–	–138	–	dBm/Hz	
	2010-2075 MHz (TDSCDMA)	–	–126	–	dBm/Hz	
	2110-2170 MHz (WCDMA)	–	–125	–	dBm/Hz	
	2305-2370 (LTE band 40)	–	–105	–	dBm/Hz	
	2370-2400 (LTE band 40)	–	–75	–	dBm/Hz	
	2496-2530 (LTE band 41)	–	–95	–	dBm/Hz	
	2530-2560 (LTE band 41)	–	–109	–	dBm/Hz	
2570-2690 (LTE band 41)	–	–112	–	dBm/Hz		
5000-5900 (WLAN 5G)	–	–	–155	–	dBm/Hz	
EVM Does Not Exceed						
TX power at the chip port for highest power level setting at 25°C and V _{BAT} = 3.6V with spectral mask and EVM compliance	DSSS	–9 dB	20.0	20.0	–	dBm
	BPSK	–5 dB	21.0	21.0	–	dBm
	16-QAM	–19 dB	21.0	21.0	–	dBm
	64-QAM	–25 dB	19.7	21.0	–	dBm
	64-QAM HT 20	–27 dB	18.6	20.0	–	dBm
	16-QAM HT 40	–19 dB	18.5	19.0	–	dBm
	64-QAM HT 40	–27 dB	17.5	18.0	–	dBm
Phase noise	37.4 MHz crystal, integrated from 10 kHz to 10 MHz	–	0.3	0.4	Degrees	
TX power control dynamic range	–	10	–	–	dB	
Closed-loop TX power variation at highest power level setting	Across full temperature and voltage range. Applies to 10 dBm to 20 dBm output power range.	–	±1.5	±2	dB	
Carrier suppression	–	30	–	–	dBc	
Gain control step	–	–	0.25	–	dB	
Return loss at Chip port TX	Z _o = 50Ω	–	3	–	dB	

1. The cellular standards listed indicate only typical usages of that band in some countries. Other standards may also be used within those bands.

16.4 WLAN 5 GHz Receiver Performance Specifications

Note: Unless otherwise noted, the values shown in the following table are provided at the chip port input.

Table 34. WLAN 5 GHz Receiver Performance Specifications

Parameter	Condition/Notes	Min	Typ	Max	Unit
Frequency range	–	4900	–	5845	MHz
RX sensitivity IEEE 802.11a (10% PER for 1000 octet PSDU)	6 Mbps OFDM	–92.0	–94.0	–	dBm
	9 Mbps OFDM	–91.1	–92.7	–	dBm
	12 Mbps OFDM	–	–92.0	–	dBm
	18 Mbps OFDM	–87.6	–89.0	–	dBm
	24 Mbps OFDM	–	–86.3	–	dBm
	36 Mbps OFDM	–80.9	–82.7	–	dBm
	48 Mbps OFDM	–	–78.3	–	dBm
	54 Mbps OFDM	–75.0	–76.9	–	dBm
RX sensitivity IEEE 802.11n (10% PER for 4096 octet PSDU) Defined for default parameters: 800 ns GI and non-STBC	20 MHz channel spacing for all MCS rates				
	MCS0	–92.3	–94.0	–	dBm
	MCS1	–	–92.5	–	dBm
	MCS2	–87.6	–90.0	–	dBm
	MCS3	–	–87.2	–	dBm
	MCS4	–81.5	–83.7	–	dBm
	MCS5	–	–79.4	–	dBm
	MCS6	–	–78.0	–	dBm
	MCS7	–74.0	–76.2	–	dBm
RX sensitivity IEEE 802.11n (10% PER for 4096 octet PSDU) Defined for default parameters: 800 ns GI and non-STBC.	40 MHz channel spacing for all MCS rates				
	MCS0	–89.3	–91.3	–	dBm
	MCS1	–	–90.1	–	dBm
	MCS2	–85.7	–87.4	–	dBm
	MCS3	–	–84.6	–	dBm
	MCS4	–79.6	–81.0	–	dBm
	MCS5	–	–76.7	–	dBm
	MCS6	–	–75.2	–	dBm
	MCS7	–72.0	–73.5	–	dBm
RX sensitivity IEEE 802.11ac (10% PER for 4096 octet PSDU) Defined for default parameters: 800 ns GI and non-STBC.	20 MHz channel spacing for all MCS rates				
	MCS0	–92.3	–93.9	–	dBm
	MCS1	–	–92.4	–	dBm
	MCS2	–88.0	–89.9	–	dBm
	MCS3	–	–87.3	–	dBm
	MCS4	–81.8	–83.7	–	dBm
	MCS5	–	–79.5	–	dBm
	MCS6	–	–77.9	–	dBm
	MCS7	–74.5	–76.2	–	dBm
MCS8	–69.8	–72.2	–	dBm	

Table 34. WLAN 5 GHz Receiver Performance Specifications (Cont.)

Parameter	Condition/Notes	Min	Typ	Max	Unit	
RX sensitivity IEEE 802.11ac (10% PER for 4096 octet PSDU) Defined for default parameters: 800 ns GI and non-STBC.	40 MHz channel spacing for all MCS rates					
	MCS0	-88.9	-91.3	-	dBm	
	MCS1	-	-90.2	-	dBm	
	MCS2	-85.6	-87.6	-	dBm	
	MCS3	-	-84.9	-	dBm	
	MCS4	-79.6	-81.0	-	dBm	
	MCS5	-	-77.0	-	dBm	
	MCS6	-	-75.5	-	dBm	
	MCS7	-72.3	-73.6	-	dBm	
	MCS8	-68.0	-69.5	-	dBm	
MCS9	-65.6	-67.5	-	dBm		
RX sensitivity IEEE 802.11ac (10% PER for 4096 octet PSDU) Defined for default parameters: 800 ns GI and non-STBC.	80 MHz channel spacing for all MCS rates					
	MCS0	-86.8	-88.7	-	dBm	
	MCS1	-	-86.9	-	dBm	
	MCS2	-82.6	-84.1	-	dBm	
	MCS3	-	-81.5	-	dBm	
	MCS4	-76.5	-77.7	-	dBm	
	MCS5	-	-73.7	-	dBm	
	MCS6	-	-72.3	-	dBm	
	MCS7	-68.7	-70.4	-	dBm	
	MCS8	-64.7	-66.4	-	dBm	
MCS9	-62.5	-64.4	-	dBm		
Input In-Band IP3	Maximum LNA gain	-	-9.4	-	dBm	
	Minimum LNA gain	-	12.5	-	dBm	
Maximum receive level @ 5.24 GHz	@ 6, 9, 12 Mbps	-9.5	-	-	dBm	
	@ 18, 24, 36, 48, 54 Mbps	-14.5	-	-	dBm	
Adjacent channel rejection (Difference between interfering and desired signal (20 MHz apart) at 10% PER for 1000 octet PSDU with desired signal level as specified in Condition/Notes)	6 Mbps OFDM	-79 dBm	16	29.2	-	dB
	9 Mbps OFDM	-78 dBm	15	25.4	-	dB
	12 Mbps OFDM	-76 dBm	13	-	-	dB
	18 Mbps OFDM	-74 dBm	11	22.2	-	dB
	24 Mbps OFDM	-71 dBm	8	-	-	dB
	36 Mbps OFDM	-67 dBm	4	16.5	-	dB
	48 Mbps OFDM	-63 dBm	0	-	-	dB
	54 Mbps OFDM	-62 dBm	-1	11.3	-	dB
	65 Mbps OFDM	-61 dBm	-2	-	-	dB

Table 34. WLAN 5 GHz Receiver Performance Specifications (Cont.)

Parameter	Condition/Notes	Min	Typ	Max	Unit	
Alternate adjacent channel rejection (Difference between interfering and desired signal (40 MHz apart) at 10% PER for 1000 ¹ octet PSDU with desired signal level as specified in Condition/Notes)	6 Mbps OFDM	-78.5 dBm	32	44.8	-	dB
	9 Mbps OFDM	-77.5 dBm	31	42.8	-	dB
	12 Mbps OFDM	-75.5 dBm	29	-	-	dB
	18 Mbps OFDM	-73.5 dBm	27	39.0	-	dB
	24 Mbps OFDM	-70.5 dBm	24	-	-	dB
	36 Mbps OFDM	-66.5 dBm	20	32.7	-	dB
	48 Mbps OFDM	-62.5 dBm	16	-	-	dB
	54 Mbps OFDM	-61.5 dBm	15	26.7	-	dB
	65 Mbps OFDM	-60.5 dBm	14	27.5	-	dB
Maximum receiver gain	-	67	70.5	74.5	dB	
Gain control step	-	-	3	-	dB	
RSSI accuracy ²	Range -90 dBm to -30 dBm	-5	-	5	dB	
	Range above -30 dBm	-8	-	8	dB	
Return loss	Z ₀ = 50Ω, across the dynamic range	-	12.5	-	dB	
Receiver cascaded noise figure	At maximum gain	-	5	-	dB	

- For 65 Mbps, the size is 4096.
- The minimum and maximum values shown have a 95% confidence level.

16.5 WLAN 5 GHz Transmitter Performance Specifications

Note: Unless otherwise noted, the values shown in the following table are provided at the WLAN chip port output

Table 35. WLAN 5 GHz Transmitter Performance Specifications

Parameter	Condition/Notes	Min	Typ	Max	Unit	
Frequency range	–	4900	–	5845	MHz	
Transmitted power in cellular and bands (at +18.5 dBm, 100% duty cycle, 6 Mbps OFDM) ¹	776–794 MHz (CDMA2000)	–	–170	–	dBm/Hz	
	869–960 MHz (cdmaOne, GSM850)	–	–170	–	dBm/Hz	
	1450–1495 (DAB)	–	–169	–	dBm/Hz	
	1570–1580 MHz (GPS)	–	–169	–	dBm/Hz	
	1592–1610 MHz (GLONASS)	–	–169	–	dBm/Hz	
	1710–1800(DSC-1800-Uplink)	–	–169	–	dBm/Hz	
	1805–1880 MHz (GSM 1800)	–	–169	–	dBm/Hz	
	1850–1910 MHz (GSM 1900)	–	–169	–	dBm/Hz	
	1910–1930 MHz (TDSCDMA, LTE)	–	–169	–	dBm/Hz	
	1930–1990 MHz (GSM1900, cdmaOne, WCDMA)	–	–165	–	dBm/Hz	
	2010–2075 MHz (TDSCDMA)	–	–164.5	–	dBm/Hz	
	2110–2170 MHz (WCDMA)	–	–163	–	dBm/Hz	
	2305–2370 (LTE band 40)	–	–158	–	dBm/Hz	
	2370–2400 (LTE band 40)	–	–162	–	dBm/Hz	
	2400–2500 (WLAN 2G)	–	–160	–	dBm/Hz	
	2496–2530 (LTE band 41)	–	–161.5	–	dBm/Hz	
2530–2560 (LTE band 41)	–	–161.5	–	dBm/Hz		
2570–2690 (LTE band 41)	–	–159	–	dBm/Hz		
EVM Does Not Exceed						
TX power at the chip port for highest power level setting at 25°C and V _{BAT} = 3.6V with spectral mask and EVM compliance	BPSK	–5 dB	18.0	21.0	–	dBm
	QPSK	–13 dB	18.0	21.0	–	dBm
	16-QAM	–19 dB	17.2	21.0	–	dBm
	64-QAM	–25 dB	16.6	20.0	–	dBm
	64-QAM HT20	–27 dB	16.0	19.0	–	dBm
	256-QAM VHT20 ²	–30 dB	12.5	18.0	–	dBm
	256-QAM VHT40 MCS8 NSS1 ²	–30 dB	13.7	17.0	–	dBm
	256-QAM VHT40 MCS8 NSS1 ²	–32 dB	12.2	16.5	–	dBm
	256-QAM VHT80 MCS8 NSS1 ²	–30 dB	13.0	17.5	–	dBm
	256-QAM VHT80 MCS8 NSS1 ²	–32 dB	10.9	15.5	–	dBm
Phase noise	37.4 MHz Crystal, Integrated from 10 kHz to 10 MHz	–	0.4	0.5	Degrees	
TX power control dynamic range	–	10	–	–	dB	
Closed loop TX power variation at highest power level setting	Across full-temperature and voltage range. Applies across 10 to 20 dBm output power range.	–	±1.5	±2.5	dB	
Carrier suppression	–	25	–	–	dBc	
Gain control step	–	–	0.25	–	dB	
Return loss	Z ₀ = 50Ω	–	5	–	dB	

1. The cellular standards listed indicate only typical usages of that band in some countries. Other standards may also be used within those bands.
 2. With Full channel estimation ON -improved by 1.5-2 dBm.

16.6 .General Spurious Emissions Specifications

This section provides the TX and RX spurious emissions specifications for both the WLAN 2.4 GHz and 5 GHz bands. The recommended spectrum analyzer settings for the spurious emissions specifications are provided in [Table 36](#).

Table 36. Recommended Spectrum Analyzer Settings

Parameter	Setting
Resolution Bandwidth	1 MHz
Video Bandwidth	10 MHz
Sweep	Auto
Span	Variable
Detector	Maximum Peak
Trace	Maximum Hold
Modulation	Orthogonal Frequency-division Multiplexing (OFDM)

16.6.1 2.4 GHz Band Spurious Emissions

20 MHz Channel Spacing

Table 37. 2.4 GHz Band, 20 MHz Channel Spacing TX Spurious Emissions Specifications

Emissions Frequency Range (MHz)	Channel Power (dBm)	Spurious Emission Level (2442 MHz) Typ (dBm)
1000 – 2000	21	-44
2000 - 2400	21	-40
2500 - 3000	21	-40
3000 - 4000	21	-40
4000 - 5000	21	-16
5000 - 6000	21	-47
6000 – 7000	21	-48
7000 – 8000	21	-15
8000 – 10000	21	-45
10000 – 12000	21	-50
12000 – 15000	21	-49
15000 – 20000	21	-48

16.6.2 5 GHz Band Spurious Emissions

20 MHz Channel Spacing

Table 38. 5 GHz Band, 20 MHz Channel Spacing TX Spurious Emissions Specifications

Emissions Frequency Range (MHz)	Channel Power (dBm)	Spurious Emission Level (Typical) (dBm)		
		CH5180	CH5500	CH5825
1000 – 2000	19	-48	-48	-48
2000 - 3000	19	-48	-47	-48
3000 - 4000	19	-43	-44	-43
4000 - 5000	19	-46	-46	-46
5000 - 6000	19	-43	-42	-40
6000 – 7000	19	-43	-48	-41
7000 – 8000	19	-48	-45	-48
8000 – 10000	19	-48	-48	-49
10000 – 12000	19	-11	-15	-16
12000 – 15000	19	-47	-46	-47
15000 – 20000	19	-20	-22	-22

40 MHz Channel Spacing

Table 39. 5 GHz Band, 40 MHz Channel Spacing TX Spurious Emissions Specifications

Emissions Frequency Range (MHz)	Channel Power (dBm)	Spurious Emission Level (Typical) (dBm)		
		CH5190m	CH5510m	CH5795m
1000 – 2000	19	-48	-48	-48
2000 - 3000	19	-48	-48	-48
3000 - 4000	19	-43	-43	-42
4000 - 5000	19	-45	-46	-47
5000 - 6000	19	-42	-42	-42
6000 – 7000	19	-44	-48	-46
7000 – 8000	19	-48	-46	-48
8000 – 10000	19	-48	-48	-48
10000 – 12000	19	-16	-18	-19
12000 – 15000	19	-46	-46	-46
15000 – 20000	19	-26	-27	-27

80 MHz Channel Spacing

Table 40. 5 GHz Band, 80 MHz Channel Spacing TX Spurious Emissions Specifications

Emissions Frequency Range (MHz)	Channel Power (dBm)	Spurious Emission Level (Typical) (dBm)		
		CH5210q	CH5530q	CH5775q
1000 – 2000	19	-48	-48	-48
2000 - 3000	19	-48	-48	-48
3000 - 4000	19	-41	-41	-41
4000 - 5000	19	-38	-47	-47
5000 - 6000	19	-40	-40	-40
6000 – 7000	19	-44	-48	-46
7000 – 8000	19	-48	-46	-48
8000 – 10000	19	-50	-50	-50
10000 – 12000	19	-19	-23	-23
12000 – 15000	19	-47	-47	-47
15000 – 20000	19	-27	-30	-31

16.6.3 Receiver Spurious Emissions Specifications

Table 41. 2G and 5G General Receiver Spurious Emissions

Band	Frequency Range	Emission (Typical)	Unit
2G	2.4 GHz < f < 2.5 GHz	-89	dBm
	3.6 GHz < f < 3.8 GHz	-62	dBm
5G	5.15 GHz < f < 5.85 GHz	-63	dBm
	3.45 GHz < f < 3.9 GHz	-53	dBm

17. Internal Regulator Electrical Specifications

17.1 Core Buck Switching Regulator

Note: Values in this data sheet are design goals and are subject to change based on device characterization results.

Note: Functional operation is not guaranteed outside of the specification limits provided in this section.

Table 42. Core Buck Switching Regulator (CBUCK) Specifications

Specification	Notes	Min	Typ	Max	Unit
Input supply voltage (DC)	DC voltage range inclusive of disturbances.	3.0	3.6	4.8 ¹	V
PWM mode switching frequency	CCM, Load > 100 mA $V_{BAT} = 3.6$ V	–	4	–	MHz
PWM output current	–	–	–	600	mA
Output current limit	–	–	1400	–	mA
Output voltage range	Programmable, 30 mV steps. Default = 1.35 V	1.2	1.35	1.5	V
PWM output voltage DC accuracy	Includes load and line regulation. Forced PWM mode.	–4	–	4	%
PWM ripple voltage, static	Measure with 20 MHz bandwidth limit. Static Load. Max. Ripple based on $V_{BAT} = 3.6$ V, $V_{out} = 1.35$ V, $F_{sw} = 4$ MHz, 2.2 μ H inductor L > 1.05 μ H, Cap + Board total-ESR < 20 m Ω , $C_{out} > 1.9$ μ F, ESL < 200 pH	–	7	20	mVpp
PWM mode peak efficiency	Peak Efficiency at 200 mA load with 0806 inductor (see external inductor row below)	78	86	–	%
	Peak Efficiency at 200 mA load with 0603 inductor (see external inductor row below)	78	84	–	%
PFM mode efficiency	10mA load current with 0603 inductor (see external inductor row below)	70	80	–	%
	10mA load current with 0806 inductor (see external inductor row below)	70	76	–	%
Start-up time from power down	VIO already ON and steady. Time from REG_ON rising edge to CLDO reaching 1.2V.	–	400	500	μ s
External inductor	0603 size, 2.2 μ H, DCR = 0.3 Ω , ACR = 1.34 Ω @ 4 MHz OR 0806 size, 2.2 μ H, DCR = 0.11 Ω , ACR = 1.18 Ω @ 4 MHz	–	2.2	–	μ H
External output capacitor	Ceramic, X5R, 0402, ESR < 30 m Ω at 4 MHz, 4.7 μ F \pm 20%, 6.3V	2.0	4.7	10 ²	μ F
External input capacitor	For SR_VDDBATP5V pin, ceramic, X5R, 0603, ESR < 30 m Ω at 4 MHz, \pm 4.7 μ F \pm 20%, 6.3 V	0.67 ²	4.7	–	μ F
Input supply voltage ramp-up time	0 to 4.3 V	40	–	–	μ s

1. The maximum continuous voltage is 4.8V. Voltages up to 5.5V for up to 10 seconds, cumulative duration, over the lifetime of the device are allowed.
2. Total capacitance includes those connected at the far end of the active load.

17.2 3.3V LDO (LDO3P3)

Table 43. LDO3P3 Specifications

Specification	Notes	Min	Typ	Max	Unit
Input supply voltage, V_{in}	Min. = $V_o + 0.2\text{ V} = 3.5\text{ V}$ dropout voltage requirement must be met under maximum load for performance specifications.	3.0	3.6	4.8 ¹	V
Output current	–	0.001	–	450	mA
Nominal output voltage, V_o	–	–	3.3	–	V
Dropout voltage	At max. load.	–	–	200	mV
Output voltage DC accuracy	Includes line/load regulation.	–5	–	+5	%
Quiescent current	No load	–	–	200	μA
Line regulation	V_{in} from ($V_o + 0.2\text{ V}$) to 5.25 V, max. load	–	–	3.5	mV/V
Load regulation	load from 1 mA to 450 mA	–	–	0.3	mV/mA
PSRR	$V_{in} \geq V_o + 0.2$, $V_o = 3.3\text{ V}$, $C_o = 4.7\text{ }\mu\text{F}$, Max. load, 100 Hz to 100 kHz	20	–	–	dB
LDO turn-on time	Chip already powered up.	–	160	250	μs
External output capacitor, C_o	Ceramic, X5R, 0402, (ESR: 5 m Ω –240 m Ω), $\pm 10\%$, 10V	1.0 ²	4.7	10	μF
External input capacitor	For SR_VDDBATA5V pin (shared with Bandgap) Ceramic, X5R, 0402, (ESR: 30m-200 m Ω), $\pm 10\%$, 10V. Not needed if sharing V_{BAT} capacitor 4.7 μF with SR_VDDBATP5V.	–	4.7	–	μF

1. The maximum continuous voltage is 4.8V. Voltages up to 5.5V for up to 10 seconds, cumulative duration, over the lifetime of the device are allowed.
2. Minimum capacitor value refers to the residual capacitor value after taking into account the part-to-part tolerance, DC-bias, temperature, and aging.

17.3 2.5V LDO (BTLDO2P5)

Table 44. BTLDO2P5 Specifications

Specification	Notes	Min	Typ	Max	Unit
Input supply voltage	Min. = 2.5 V + 0.2 V = 2.7 V. Dropout voltage requirement must be met under maximum load for performance specifications.	3.0	3.6	4.8 ¹	V
Nominal output voltage	–	–	2.8	–	V
Output voltage programmability	Range	2.2	2.5	2.8	V
	Accuracy at any step (including line/load regulation), load > 0.1 mA.	–5	–	5	%
Dropout voltage	At maximum load.	–	–	200	mV
Output current	–	0.1	–	70	mA
Quiescent current	No load.	–	57	100	µA
	Maximum load at 70 mA.	–	704	1000	µA
Leakage current	Power-down mode.	–	1.5	5	µA
Line regulation	V _{in} from (V _o + 0.2 V) to 5.25 V, maximum load.	–	–	3.5	mV/V
Load regulation	Load from 1 mA to 70 mA, V _{in} = 3.6V.	–	–	0.3	mV/mA
PSRR	V _{in} ≥ V _o + 0.2 V, V _o = 2.5 V, C _o = 2.2 µF, maximum load, 100 Hz to 100 kHz.	20	–	–	dB
LDO turn-on time	Chip already powered up.	–	–	150	µs
In-rush current	V _{in} = V _o + 0.15 V to 5.25 V, C _o = 2.2 µF, No load.	–	–	250	mA
External output capacitor, C _o	Ceramic, X5R, 0402, (ESR: 5m–240 mΩ), ±10%, 10 V	0.7 ²	2.2	2.64	µF
External input capacitor	For SR_VDDBATA5V pin (shared with Bandgap) ceramic, X5R, 0402, (ESR: 30–200 mΩ), ±10%, 10 V. Not needed if sharing V _{BAT} 4.7 µF capacitor with SR_VDDBATP5V.	–	4.7	–	µF

1. The maximum continuous voltage is 4.8V. Voltages up to 5.5V for up to 10 seconds, cumulative duration, over the lifetime of the device are allowed.
2. The minimum value refers to the residual capacitor value after taking into account part-to-part tolerance, DC-bias, temperature, and aging.

17.4 CLDO
Table 45. CLDO Specifications

Specification	Notes	Min	Typ	Max	Unit
Input supply voltage, V_{in}	Min. = $1.2 + 0.15 \text{ V} = 1.35\text{V}$ dropout voltage requirement must be met under maximum load.	1.3	1.35	1.5	V
Output current	–	0.2	–	200	mA
Output voltage, V_o	Programmable in 10 mV steps. Default = 1.2 V	0.95	1.2	1.26	V
Dropout voltage	At max. load	–	–	150	mV
Output voltage DC accuracy	Includes line/load regulation	–4	–	+4	%
Quiescent current	No load	–	22	–	μA
	200 mA load	–	2.24	–	mA
Line Regulation	V_{in} from ($V_o + 0.15 \text{ V}$) to 1.5 V, maximum load	–	–	5	mV/V
Load Regulation	Load from 1 mA to 200 mA	–	0.02	0.05	mV/mA
Leakage Current	Power down	–	5	20	μA
	Bypass mode	–	1	3	μA
PSRR	@1 kHz, $V_{in} \geq 1.35 \text{ V}$, $C_o = 4.7 \mu\text{F}$	20	–	–	dB
Start-up Time of PMU	VIO up and steady. Time from the REG_ON rising edge to the CLDO reaching 1.2 V.	–	–	700	μs
LDO Turn-on Time	LDO turn-on time when rest of the chip is up	–	140	180	μs
External Output Capacitor, C_o	Total ESR: 5 m Ω –240 m Ω	1.1 ¹	2.2	–	μF
External Input Capacitor	Only use an external input capacitor at the VDD_LDO pin if it is not supplied from CBUCK output.	–	1	2.2	μF

1. Minimum capacitor value refers to the residual capacitor value after taking into account the part-to-part tolerance, DC-bias, temperature, and aging.

17.5 LNLDO

Table 46. LNLDO Specifications

Specification	Notes	Min	Typ	Max	Unit
Input supply voltage, V_{in}	Min. $V_{IN} = V_o + 0.15 V = 1.35 V$ (where $V_o = 1.2 V$) dropout voltage requirement must be met under maximum load.	1.3	1.35	1.5	V
Output Current	–	0.1	–	150	mA
Output Voltage, V_o	Programmable in 25 mV steps. Default = 1.2 V	1.1	1.2	1.275	V
Dropout Voltage	At maximum load	–	–	150	mV
Output Voltage DC Accuracy	Includes line/load regulation	–4	–	+4	%
Quiescent current	No load	–	67	–	μA
	Max. load	–	930	1800	μA
Line Regulation	V_{in} from ($V_o + 0.1 V$) to 1.5 V, 150 mA load	–	–	5	mV/V
Load Regulation	Load from 1 mA to 150 mA	–	0.02	0.05	mV/mA
Leakage Current	Power-down	–	–	10	μA
Output Noise	@30 kHz, 60–150 mA load $C_o = 2.2 \mu F$	–	–	60	nV/rt Hz
	@100 kHz, 60–150 mA load $C_o = 2.2 \mu F$	–	–	35	nV/rt Hz
PSRR	@ 1kHz, Input > 1.35 V, $C_o = 2.2 \mu F$, $V_o = 1.2 V$	20	–	–	dB
LDO Turn-on Time	LDO turn-on time when rest of chip is up	–	140	180	μs
External Output Capacitor, C_o	Total ESR (trace/capacitor): 5 m Ω –240 m Ω	0.5 ¹	2.2	4.7	μF
External Input Capacitor	Only use an external input capacitor at the VDD_LDO pin if it is not supplied from CBUCK output. Total ESR (trace/capacitor): 30 m Ω –200 m Ω	–	1	2.2	μF

1. Minimum capacitor value refers to the residual capacitor value after taking into account the part-to-part tolerance, DC-bias, temperature, and aging.

17.6 HLDO

Table 47. HLDO Specifications

Parameter	Conditions	Min	Typ	Max	Unit
Input Supply Voltage, V_{in}	Min $V_{in} = V_o + 0.15 \text{ V} = 1.35 \text{ V}$ (for $V_o = 1.2 \text{ V}$)	1.3	1.35	1.5	V
	dropout voltage requirement need to be met under max load				
Output Current	Peak load= 55mA, average = 35mA	0.1	–	55	mA
Output Voltage Programmability	Range	1.1	1.2	1.275	V
	Step Size	–	25	–	mV
	Accuracy at any Step (including line/load regulation)	-4	–	4	%
Dropout Voltage	at max load	–	–	150	mV
Output Current	Peak load = 55mA, average = 35mA	0.1		55	mA
Quiescent Current	No-load	–	40	100	uA
	55mA load	–	613	1000	uA
Line Regulation	V_{in} from ($V_o + 0.15 \text{ V}$) to 1.5 V; 55mA load	–	5	–	mV/V
Load Regulation	load from 1mA to 55mA; $V_{in} \geq (V_o + 0.15 \text{ V})$	–	0.045	0.05	mV/mA
Leakage Current	Power-down. Junction Temp 85C	–	1	6	uA
	Bypass mode	–	0.4	1.7	uA
PSRR	@1-kHz, $V_{in} \geq V_o + 0.15 \text{ V}$, $C_o = 0.47\mu\text{F}$	20			dB
Start-up Time of PMU	VIO up & steady. Time from REG_ON rise edge to LDO reaching 99% of V_o .	–	530	700	us
LDO Turn-on Time	LDO turn-on time when rest of chip is up	–	140	180	us
External Output Capacitor, C_o	0201 size cap	0.27	1	–	uF
	$C = 0.47\mu\text{F}$, Tol = 20%, Voltage Rating = 6.3, Temp Rating = X5R				
External Input Capacitor	Only use an external input cap at VDD_LDO pin if it is not supplied from CBUCK output.	–	1	–	uF

18. System Power Consumption

Note: Values in this data sheet are design goals and are subject to change based on the results of device characterization.

Note: Unless otherwise stated, these values apply for the conditions specified in Table 27 “Recommended Operating Conditions and DC Characteristics”.

18.1 WLAN Current Consumption

The tables in this subsection show the typical, total current consumed by the CYW4373. All values shown are with the Bluetooth core in reset mode with Bluetooth off.

18.1.1 2.4 GHz Mode

Table 48. 2.4 GHz Mode WLAN Power Consumption

Mode	$V_{BAT} = 3.6V, V_{DDIO} = 1.8V, T_A = 25^\circ C$	
	V_{BAT}, mA	$V_{IO}, \mu A^1$
Sleep Modes (SDIO Interface)		
OFF ²	0.003	0.15
Sleep ³	0.03	200
IEEE Power Save: DTIM = 1, single RX ⁴	1.6	200
IEEE Power Save: DTIM = 3, single RX	0.57	200
Sleep Modes (USB Interface)		
OFF ²	0.003	0.057
Sleep ³	0.49	230
IEEE Power Save: DTIM = 1, single RX ⁴	2.354	230
IEEE Power Save: DTIM = 3, single RX	1.31	230
Active RX Modes		
Continuous RX mode: MCS7, HT20, 1SS ^{5, 6}	56	60
Continuous RX mode: MCS7, HT40, 1SS ^{5, 6}	70	60
CRS: HT20 ⁷	51	60
CRS: HT40 ⁷	61	60
Active TX Modes – Internal PA		
Continuous TX mode: 1 Mbps @ 19 dBm ⁸	320	60
Continuous TX mode: MCS7, HT20, 1SS, 1 TX @ 17.5 dBm ⁸	300	60
Continuous TX mode: MCS7, HT40, 1SS, 1 TX @ 15.5 dBm ⁸	310	60
Peak PHY Calibration Current		
Unassociated	768	510
Associated	748	560

1. VIO is specified with all pins idle (not switching) and not driving any loads.
2. WL_REG_ON and BT_REG_ON are both low. All supplies are present.
3. Idle, not associated, or inter-beacon.
4. Beacon Interval = 102.4 ms. Beacon duration = 1 ms @ 1 Mbps. Average current over 3x DTIM intervals.
5. Duty cycle is 100%. Carrier sense (CS) detect/packet receive.
6. Measured using packet engine test mode.

- 7. Carrier sense (CCA) when no carrier present.
- 8. Duty cycle is 100%.

18.1.2 5 GHz Mode

Table 49. 5 GHz Mode WLAN Power Consumption

Mode	$V_{BAT} = 3.6V, V_{DDIO} = 1.8V, T_A = 25^{\circ}C$	
	V_{BAT}, mA	$V_{IO}, \mu A^1$
Sleep Modes (SDIO Interface)		
OFF ²	0.003	0.15
Sleep ³	0.03	200
IEEE Power Save: DTIM = 1, single RX ⁴	1.1	200
IEEE Power Save: DTIM = 3, single RX ⁴	0.4	200
Sleep Modes (USB Interface)		
OFF ²	0.003	0.057
Sleep ³	0.49	230
IEEE Power Save: DTIM = 1, single RX ⁴	1.746	230
IEEE Power Save: DTIM = 3, single RX ⁴	1.17	230
Active RX Modes		
Continuous RX mode: MCS7, HT20, 1SS ^{5, 6}	75	60
Continuous RX mode: MCS8, VHT20, 1SS ^{5, 6}	76	60
Continuous RX mode: MCS9, VHT40, 1SS ^{5, 6}	89	60
Continuous RX mode: MCS9, VHT80, 1SS ^{5, 6}	126	60
CRS: HT20 ⁷	68	60
CRS: HT40 ⁷	78	60
CRS: HT80 ⁷	100	60
Active TX Modes – Internal PA		
Continuous TX mode: MCS7, HT20, 1SS, 1 TX @ 17 dBm ⁸	340	60
Continuous TX mode: MCS8, VHT20, 1SS, 1 TX @ 16 dBm ⁸	330	60
Continuous TX mode: MCS9, VHT40, 1SS, 1 TX @ 15 dBm ⁸	327	60
Continuous TX mode: MCS9, VHT80, 1SS, 1 TX @ 14.5 dBm ⁸	353	60
Peak PHY Calibration Current		
Unassociated	666	410
Associated	664	390

- 1. V_{IO} is specified with all pins idle (not switching) and not driving any loads.
- 2. WL_REG_ON and BT_REG_ON are both low. All supplies present.
- 3. Idle, not associated, or inter-beacon.
- 4. Beacon Interval = 102.4 ms. Beacon duration = 1ms @ 1Mbps. Average current over 3x DTIM intervals.
- 5. Duty cycle is 100%. Carrier sense (CS) detect/packet receive.
- 6. Measured using packet engine test mode.
- 7. Carrier sense (CCA) when no carrier present.
- 8. Duty cycle is 100%.

18.2 Bluetooth Current Consumption

The Bluetooth and BLE current consumption measurements are shown in [Table 50](#).

Note: The WLAN core is in reset (WLAN_REG_ON = low) for all measurements provided in [Table 50](#).

Note: The BT current consumption numbers are measured based on GFSK TX output power = 10 dBm.

Table 50. Bluetooth and BLE Current Consumption

Operating Mode	V _{BAT}	VDDIO	Unit
Sleep	3.9 ¹	300.0	μA
Standard 1.28s Inquiry Scan	169.9	300.0	μA
500 ms Sniff Master	153	300.0	μA
DM1/DH1 Master TX RX	28.68	0.094	mA
DM3/DH3 Master TX RX	35.43	0.122	mA
DM5/DH5 Master TX RX	36.24	0.129	mA
3DH5 RX 3DH1 TX Master	30.21	0.272	mA
HV3 Master	10.198	0.064	mA
Passive Scan 1.28s ²	172.2	300.0	μA
Adv—Unconnectable 1.00 sec	94.9	300.0	μA
Connected 1.00 sec interval Master	82.2	300.0	μA

1. This sleep current consumption number and other average current consumption numbers in this table assume the UART interface for BT. Sleep current when using the USB interface is ~800μA. Average current consumption numbers are therefore also expected to be higher when using the USB interface for BT.
2. No devices present. 1.28 second interval with a scan window of 11.25 ms

19. Interface Timing and AC Characteristics

19.1 SDIO Timing

19.1.1 SDIO Default Mode Timing

SDIO default mode timing is shown by the combination of Figure 35 and Table 51.

Figure 35. SDIO Bus Timing (Default Mode)

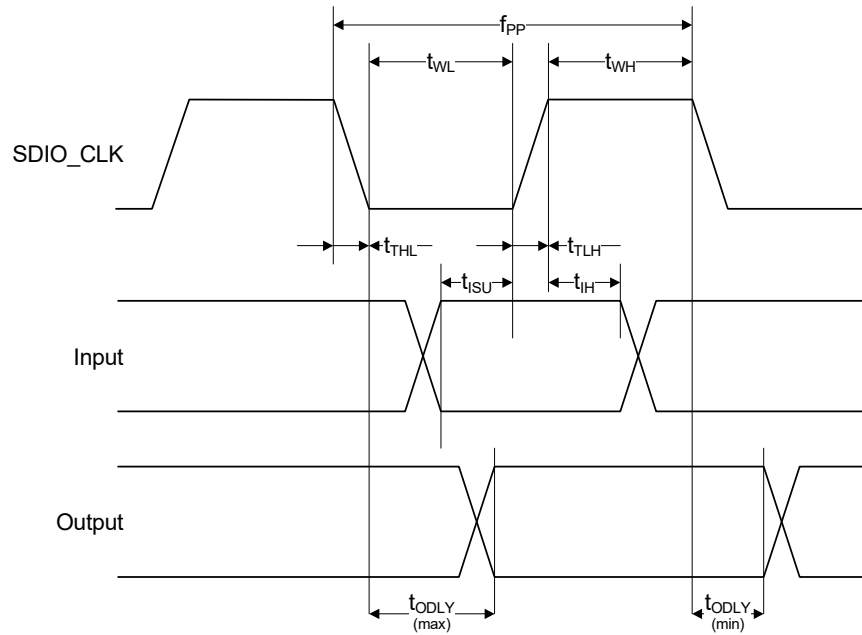

Table 51. SDIO Bus Timing¹ Parameters (Default Mode)

Parameter	Symbol	Min	Typ	Max	Unit
SDIO CLK (All values are referred to minimum V_{IH} and maximum V_{IL}^2)					
Frequency – Data Transfer mode	f_{PP}	0	–	25	MHz
Frequency – Identification mode	f_{OD}	0	–	400	kHz
Clock low time	t_{WL}	10	–	–	ns
Clock high time	t_{WH}	10	–	–	ns
Clock rise time	t_{TLH}	–	–	10	ns
Clock low time	t_{THL}	–	–	10	ns
Inputs: CMD, DAT (referenced to CLK)					
Input setup time	t_{ISU}	5	–	–	ns
Input hold time	t_{IH}	5	–	–	ns
Outputs: CMD, DAT (referenced to CLK)					
Output delay time – Data Transfer mode	t_{ODLY}	0	–	14	ns
Output delay time – Identification mode	t_{ODLY}	0	–	50	ns

1. Timing is based on $CL \leq 40$ pF load on CMD and Data.
 2. Min (V_{IH}) = $0.7 \times V_{DDIO}$ and max (V_{IL}) = $0.2 \times V_{DDIO}$.

19.1.2 SDIO High-Speed Mode Timing

SDIO high-speed mode timing is shown by the combination of Figure 36 and Table 52.

Figure 36. SDIO Bus Timing (High-Speed Mode)

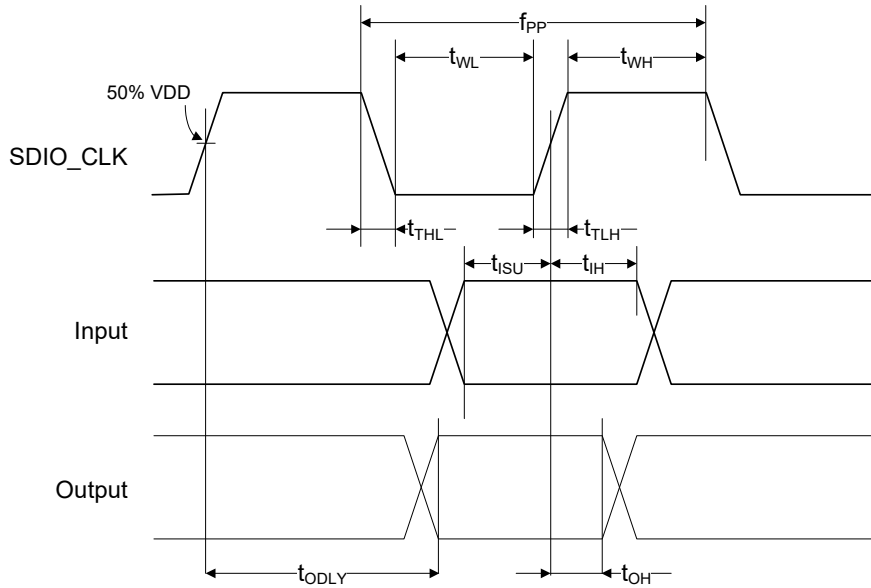

Table 52. SDIO Bus Timing¹ Parameters (High-Speed Mode)

Parameter	Symbol	Min	Typ	Max	Unit
SDIO CLK (all values are referred to minimum VIH and maximum VIL²)					
Frequency – Data Transfer Mode	f _{PP}	0	–	50	MHz
Frequency – Identification Mode	f _{OD}	0	–	400	kHz
Clock low time	t _{WL}	7	–	–	ns
Clock high time	t _{WH}	7	–	–	ns
Clock rise time	t _{TLH}	–	–	3	ns
Clock low time	t _{TLH-}	–	–	3	ns
Inputs: CMD, DAT (referenced to CLK)					
Input setup Time	t _{ISU}	6	–	–	ns
Input hold Time	t _{IH}	2	–	–	ns
Outputs: CMD, DAT (referenced to CLK)					
Output delay time – Data Transfer Mode	t _{ODLY}	–	–	14	ns
Output hold time	t _{OH}	2.5	–	–	ns
Total system capacitance (each line)	CL	–	–	40	pF

1. Timing is based on CL ≤ 40 pF load on CMD and Data.
 2. Min (VIH) = 0.7 × VDDIO and max (VIL) = 0.2 × VDDIO.

19.1.3 SDIO Bus Timing Specifications in SDR Modes

Clock Timing

Figure 37. SDIO Clock Timing (SDR Modes)

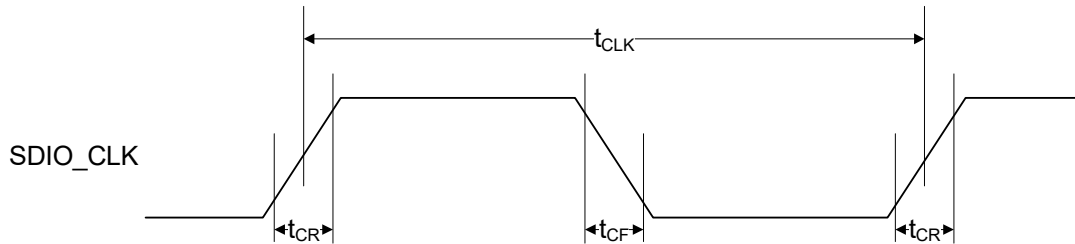

Table 53. SDIO Bus Clock Timing Parameters (SDR Modes)

Parameter	Symbol	Min	Max	Unit	Comments
–	t_{CLK}	40	–	ns	SDR12 mode
		20	–	ns	SDR25 mode
		10	–	ns	SDR50 mode
		4.8	–	ns	SDR104 mode
–	t_{CR}, t_{CF}	–	$0.2 \times t_{CLK}$	ns	$t_{CR}, t_{CF} < 2.00$ ns (max) @ 100 MHz, $C_{CARD} = 10$ pF $t_{CR}, t_{CF} < 0.96$ ns (max) @ 208 MHz, $C_{CARD} = 10$ pF
Clock duty cycle	–	30	70	%	–

Card Input Timing

Figure 38. SDIO Bus Input Timing (SDR Modes)

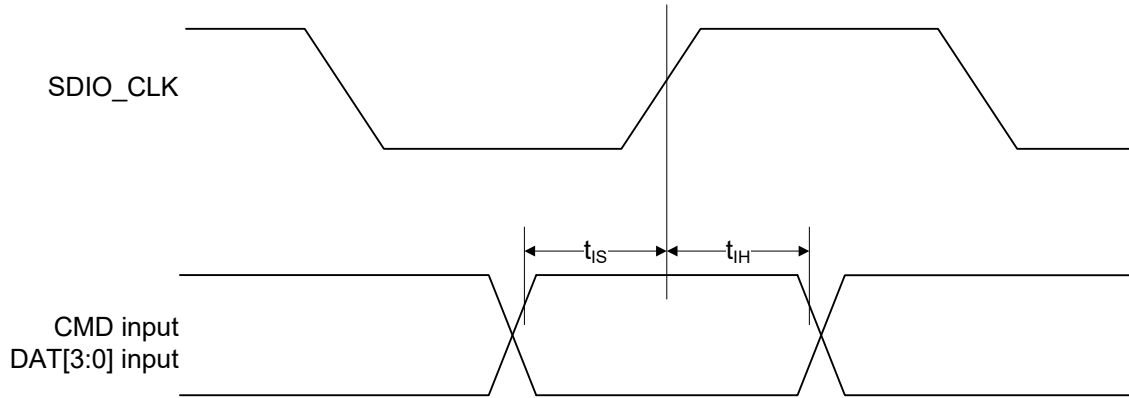

Table 54. SDIO Bus Input Timing Parameters (SDR Modes)

Symbol	Min	Max	Unit	Comments
SDR104 Mode				
t_{IS}	1.4	–	ns	$C_{CARD} = 10 \text{ pF}$, $V_{CT} = 0.975\text{V}$
t_{IH}	0.8	–	ns	$C_{CARD} = 5 \text{ pF}$, $V_{CT} = 0.975\text{V}$
SDR50 Mode				
t_{IS}	3.00	–	ns	$C_{CARD} = 10 \text{ pF}$, $V_{CT} = 0.975\text{V}$
t_{IH}	0.8	–	ns	$C_{CARD} = 5 \text{ pF}$, $V_{CT} = 0.975\text{V}$

Card Output Timing

Figure 39. SDIO Bus Output Timing (SDR Modes up to 100 MHz)

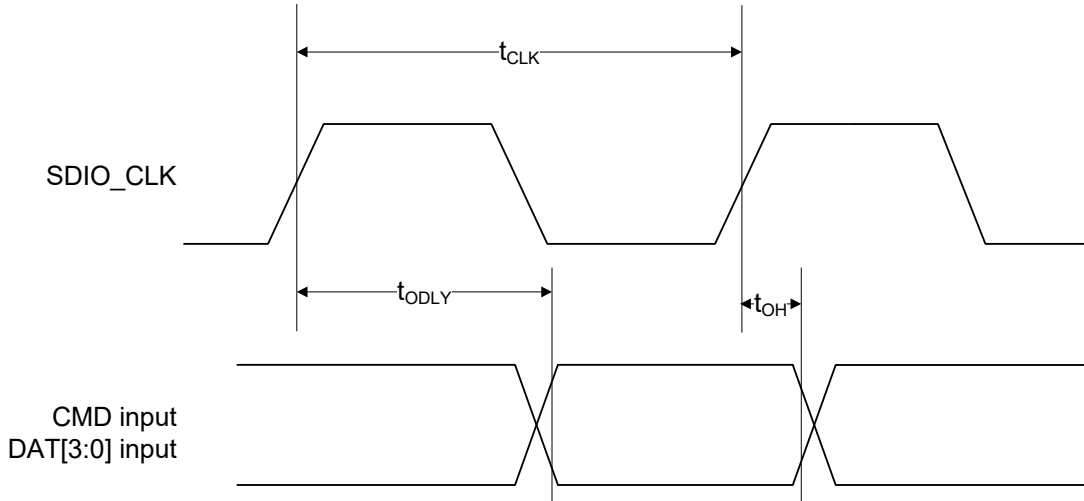

Table 55. SDIO Bus Output Timing Parameters (SDR Modes up to 100 MHz)

Symbol	Min	Max	Unit	Comments
t_{ODLY}	–	7.5	ns	$t_{CLK} \geq 10$ ns $C_L = 30$ pF using driver type B for SDR50
t_{ODLY}	–	14.0	ns	$t_{CLK} \geq 20$ ns $C_L = 40$ pF using for SDR12, SDR25
t_{OH}	1.5	–	ns	Hold time at the t_{ODLY} (min) $C_L = 15$ pF

Figure 40. SDIO Bus Output Timing (SDR Modes 100 MHz to 208 MHz)

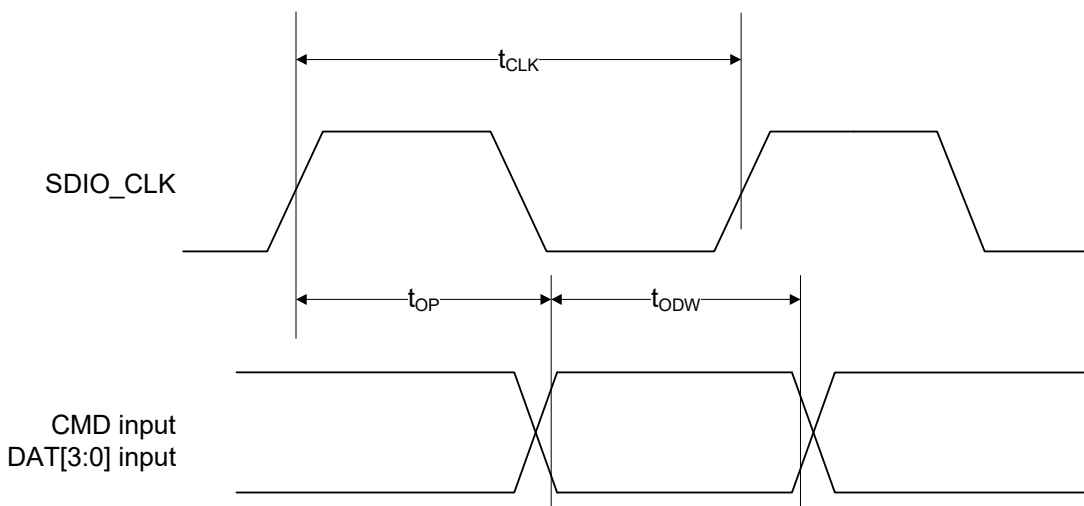
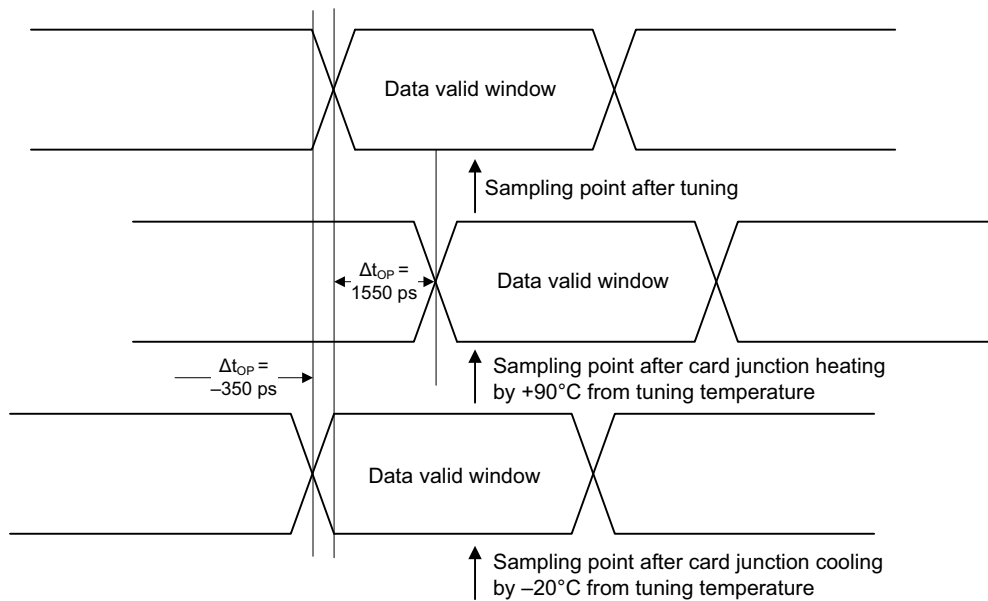

Table 56. SDIO Bus Output Timing Parameters (SDR Modes 100 MHz to 208 MHz)

Symbol	Min	Max	Unit	Comments
t_{OP}	0	2	UI	Card output phase
Δt_{OP}	-350	+1550	ps	Delay variation due to temp change after tuning
t_{ODW}	0.60	-	UI	$t_{ODW} = 2.88 \text{ ns @ 208 MHz}$

- $\Delta t_{OP} = +1550 \text{ ps}$ for junction temperature of $\Delta t_{OP} = 90^\circ\text{C}$ during operation.
- $\Delta t_{OP} = -350 \text{ ps}$ for junction temperature of $\Delta t_{OP} = -20^\circ\text{C}$ during operation.
- $\Delta t_{OP} = +2600 \text{ ps}$ for junction temperature of $\Delta t_{OP} = -20^\circ\text{C}$ to $+125^\circ\text{C}$ during operation.

Figure 41. Δt_{OP} Consideration for Variable Data Window (SDR 104 Mode)



19.1.4 SDIO Bus Timing Specifications in DDR50 Mode

Figure 42. SDIO Clock Timing (DDR50 Mode)

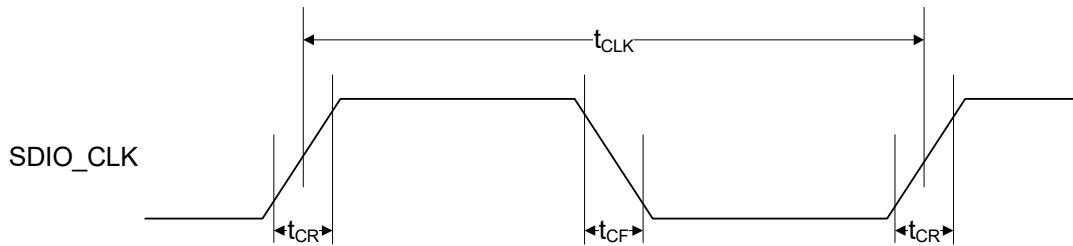

Table 57. SDIO Bus Clock Timing Parameters (DDR50 Mode)

Parameter	Symbol	Min	Max	Unit	Comments
–	t_{CLK}	20	–	ns	DDR50 mode
–	t_{CR}, t_{CF}	–	$0.2 \times t_{CLK}$	ns	$t_{CR}, t_{CF} < 4.00$ ns (max) @50 MHz, $C_{CARD} = 10$ pF
Clock duty cycle	–	45	55	%	–

Data Timing

Figure 43. SDIO Data Timing (DDR50 Mode)

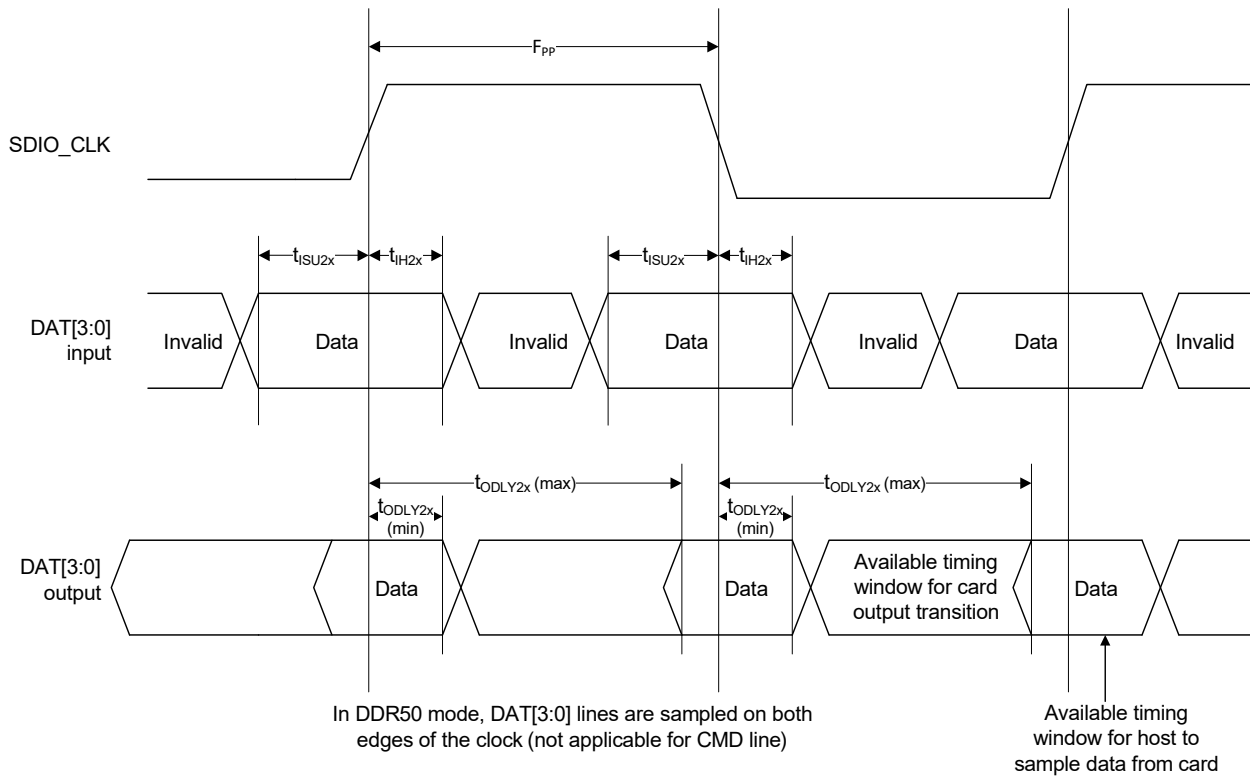

Table 58. SDIO Bus Timing Parameters (DDR50 Mode)

Parameter	Symbol	Min	Max	Unit	Comments
Input CMD					
Input setup time	t_{ISU}	6	–	ns	$C_{CARD} < 10 \text{ pF}$ (1 Card)
Input hold time	t_{IH}	0.8	–	ns	$C_{CARD} < 10 \text{ pF}$ (1 Card)
Output CMD					
Output delay time	t_{ODLY}	–	13.7	ns	$C_{CARD} < 30 \text{ pF}$ (1 Card)
Output hold time	t_{OH}	1.5	–	ns	$C_{CARD} < 15 \text{ pF}$ (1 Card)
Input DAT					
Input setup time	t_{ISU2x}	3	–	ns	$C_{CARD} < 10 \text{ pF}$ (1 Card)
Input hold time	t_{IH2x}	0.8	–	ns	$C_{CARD} < 10 \text{ pF}$ (1 Card)
Output DAT					
Output delay time	t_{ODLY2x}	–	7.5	ns	$C_{CARD} < 25 \text{ pF}$ (1 Card)
Output hold time	t_{ODLY2x}	1.5	–	ns	$C_{CARD} < 15 \text{ pF}$ (1 Card)

19.2 JTAG Timing

Table 59. JTAG Timing Characteristics

Signal Name	Period	Output Maximum	Output Minimum	Setup	Hold
TCK	125 ns	–	–	–	–
TDI	–	–	–	20 ns	0 ns
TMS	–	–	–	20 ns	0 ns
TDO	–	100 ns	0 ns	–	–
JTAG_TRST	250 ns	–	–	–	–

20. Power-Up Sequence and Timing

20.1 Sequencing of Reset and Regulator Control Signals

The CYW4373 has two signals that allow the host to control power consumption by enabling or disabling the Bluetooth, WLAN, and internal regulator blocks. These signals are described below. Additionally, diagrams are provided to indicate proper sequencing of the signals for various operational states (see [Figure 44](#), [Figure 45](#), and [Figure 46](#) and [Figure 47](#)). The timing values indicated are minimum required values; longer delays are also acceptable.

20.1.1 Description of Control Signals

- **WL_REG_ON:** Used by the PMU to power-up the WLAN section. It is also OR-gated with the BT_REG_ON input to control the internal CYW4373 regulators. When this pin is high, the regulators are enabled and the WLAN section is out of reset. When this pin is low the WLAN section is in reset. If both the BT_REG_ON and WL_REG_ON pins are low, the regulators are disabled.
- **BT_REG_ON:** Used by the PMU (OR-gated with WL_REG_ON) to power-up the internal CYW4373 regulators. If both the BT_REG_ON and WL_REG_ON pins are low, the regulators are disabled. When this pin is low and WL_REG_ON is high, the BT section is in reset.

Note: For both the WL_REG_ON and BT_REG_ON pins, there should be at least a 10 ms time delay between consecutive toggles (where both signals have been driven low). This is to allow time for the CBUCK regulator to discharge. If this delay is not followed, then there may be a VDDIO in-rush current on the order of 36 mA during the next PMU cold start.

Note: The CYW4373 has an internal POR circuit. The device will be held in reset for a maximum of 110 ms after VDDC and VDDIO have both passed the POR threshold. Wait at least 150 ms after VDDC and VDDIO are available before initiating SDIO accesses.

Note: V_{BAT} should not rise 10%–90% faster than 40 microseconds. V_{BAT} should be up before or at the same time as VDDIO. VDDIO should NOT be present first or be held high before V_{BAT} is HIGH.

20.1.2 Control Signal Timing Diagrams

Figure 44. WLAN = ON, Bluetooth = ON

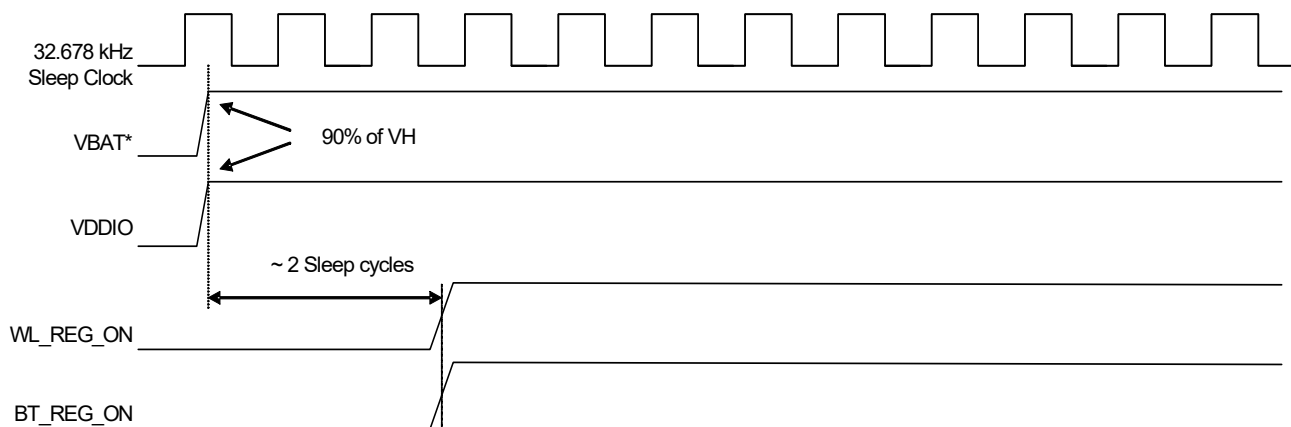

***Notes:**

1. VBAT should not rise 10%–90% faster than 40 microseconds.
2. VBAT should be up before or at the same time as VDDIO. VDDIO should NOT be present first or be held high before VBAT is high.

Figure 45. WLAN = OFF, Bluetooth = OFF

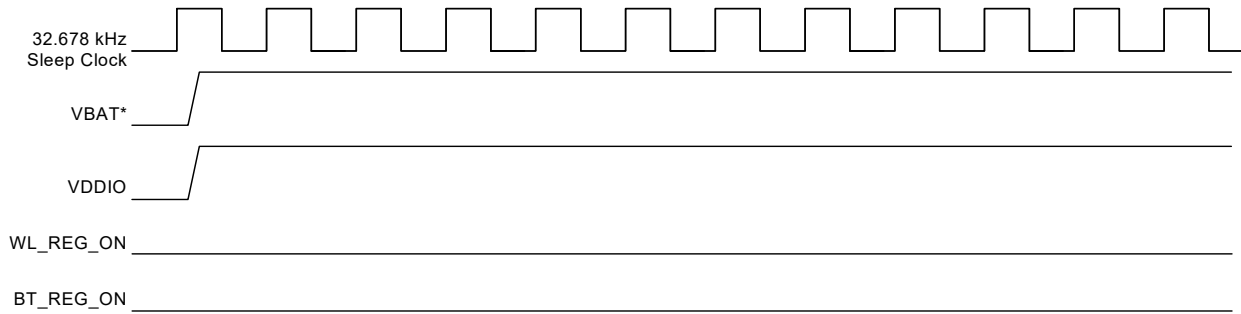

***Notes:**

1. VBAT should not rise 10%–90% faster than 40 microseconds.
2. VBAT should be up before or at the same time as VDDIO. VDDIO should NOT be present first or be held high before VBAT is high.

Figure 46. WLAN = ON, Bluetooth = OFF

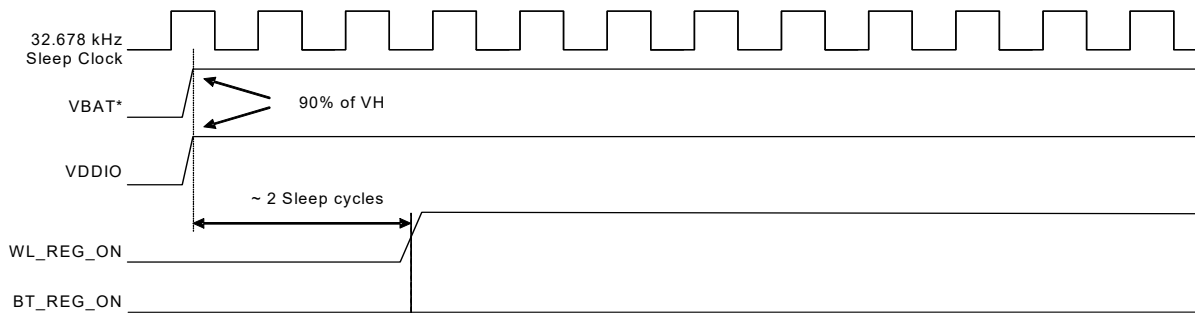

***Notes:**

1. VBAT should not rise 10%–90% faster than 40 microseconds.
2. VBAT should be up before or at the same time as VDDIO. VDDIO should NOT be present first or be held high before VBAT is high.

Figure 47. WLAN = OFF, Bluetooth = ON

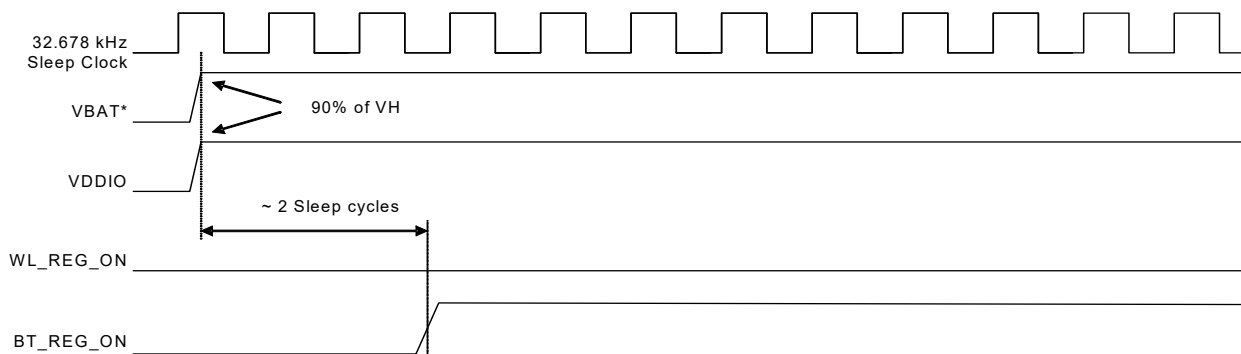

***Notes:**

1. VBAT should not rise 10%–90% faster than 40 microseconds.
2. VBAT should be up before or at the same time as VDDIO. VDDIO should NOT be present first or be held high before VBAT is high.

21. Package Information

This document provides simulated thermal data in JEDEC tests for CYW4373 in 128-WLBGA 4.51x5.43 package.

21.1 Package Thermal Characteristics

The information in Table 63 is based on the following conditions:

- No heat sink, TA = 70°C. This is an estimate, based on a 4-layer PCB that conforms to EIA/JESD51–7 (101.6 mm × 101.6 mm × 1.6 mm) and P = 0.96W continuous dissipation.
- Absolute junction temperature limits are maintained through active thermal monitoring or turning off one of the TX chains, or both.

Table 60. WLBGA Package Thermal Characteristics

Characteristic	WLBGA
θ_{JA} (°C/W) (value in still air)	37.75
θ_{JB} (°C/W)	5.90
θ_{JC} (°C/W)	4.48
Ψ_{JT} (°C/W)	11.50
Ψ_{JB} (°C/W)	22.50
Maximum Junction Temperature T _j (°C)	139.3
Maximum Power Dissipation (W)	1.84

21.2 Junction Temperature Estimation and Ψ_{JT} Versus θ_{JC}

Package thermal characterization parameter Ψ_{JT} yields a better estimation of actual junction temperature (T_j) versus using the junction-to-case thermal resistance parameter θ_{JC} . The reason for this is that θ_{JC} assumes that all the power is dissipated through the top surface of the package case. In actual applications, some of the power is dissipated through the bottom and sides of the package. Ψ_{JT} takes into account power dissipated through the top, bottom, and sides of the package. The equation for calculating the device junction temperature is:

$$T_J = T_T + P \times \Psi_{JT}$$

Where:

- T_j = Junction temperature at steady-state condition (°C)
- T_T = Package case top center temperature at steady-state condition (°C)
- P = Device power dissipation (Watts)
- Ψ_{JT} = Package thermal characteristics; no airflow (°C/W)

21.3 Environmental Characteristics

For environmental characteristics data, see [Table 25 “Environmental Ratings”](#).

22. Mechanical Information

Figure 48. 128-Ball WLBGA Package Mechanical Information

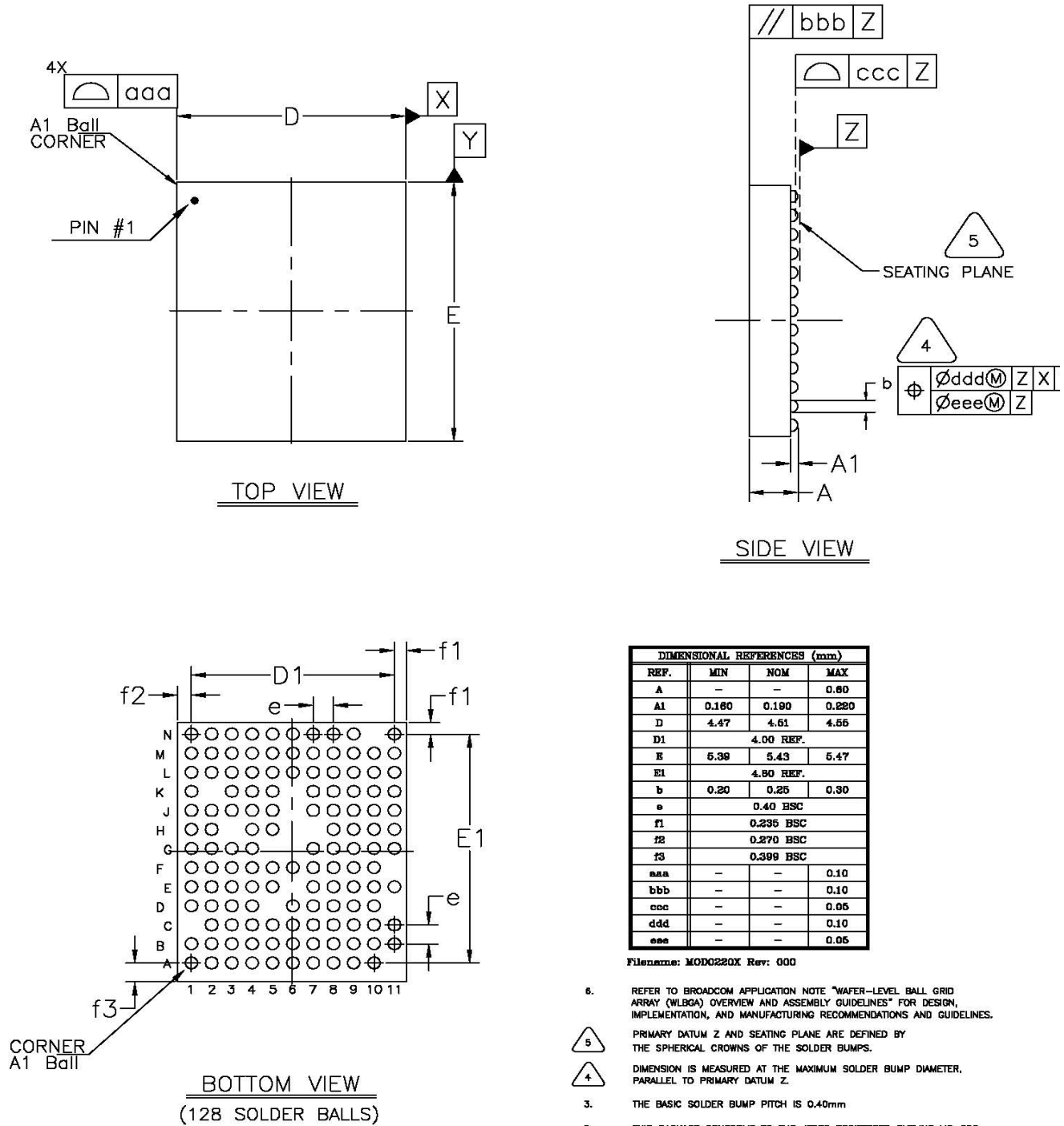
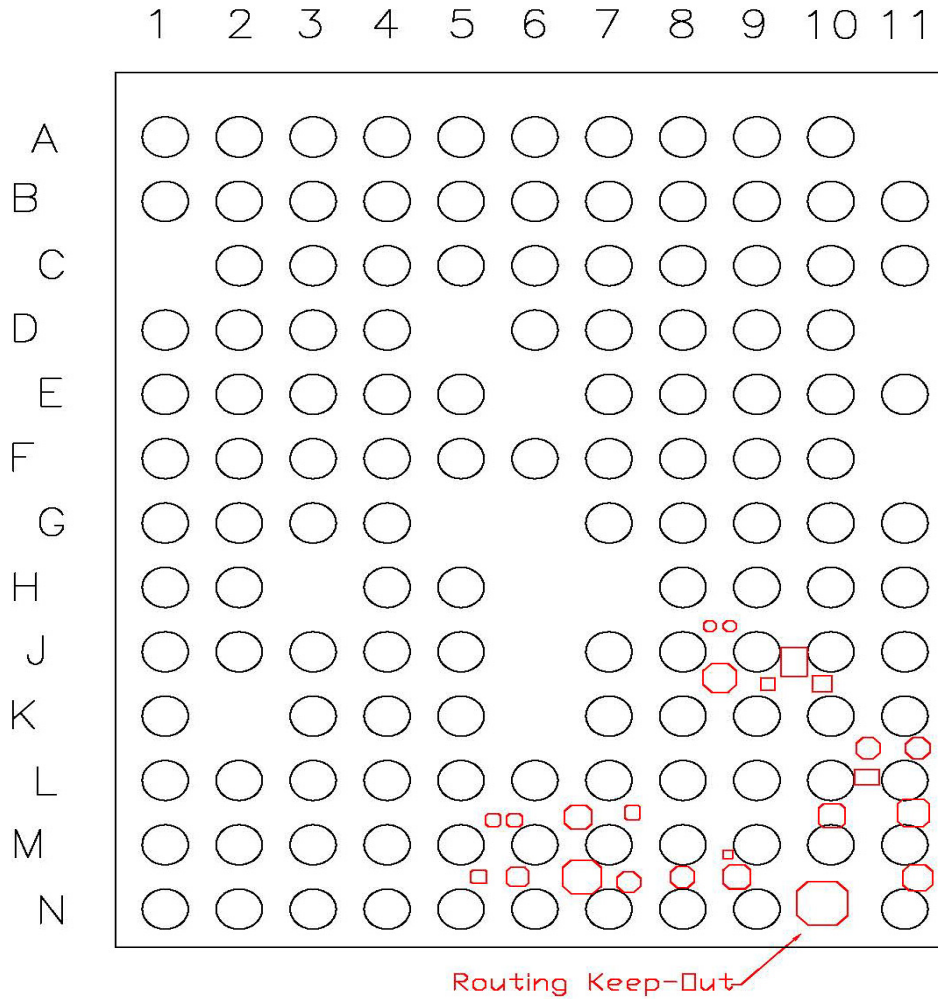

Figure 49. 128-Balls WLBGA Keep-out Areas for PCB Layout—Top View with Balls Facing Down



Note: No top-layer metal is allowed in keep-out areas.

Note: A DXF file for the WLBGA keep-out area is available for importation into a layout program. Contact your Cypress FAE for more information.

23. Ordering Information

Table 61. Part Ordering Information

Part Number	Package	Description	Operating Ambient Temperature
CYW4373IUBGT	128-ball WLBGA (4.51 mm × 5.43 mm, 0.4 mm pitch)	Dual-band 2.4 GHz and 5 GHz WLAN + BT 5.0 (with shared BT and Wi-Fi 2.4 GHz antenna)	–20°C to +70°C
CYW43732XKUBGT	128-ball WLBGA (4.51 mm × 5.43 mm, 0.4 mm pitch)	Dual-band 2.4 GHz and 5 GHz WLAN + BT 5.0 (with dedicated separate BT antenna)	–20°C to +70°C

Note: "T" at the end of part number implies Tape and Reel.

24. Additional Information

24.1 Acronyms and Abbreviations

In most cases, acronyms and abbreviations are defined upon first use. For a more complete list of acronyms and other terms used in Cypress documents, go to: <http://www.cypress.com/glossary>.

Term	Description
AES	Advanced Encryption Standard
AES-CTR	Advanced Encryption Standard-Counter Mode
ALU	Arithmetic logic unit
APB	advanced peripheral bus
APU	audio processing unit
CBC-MAC	Cipher Block Chaining Message Authentication Code
CCK	Complementary Code Keying
CCM	Counter with Cipher block chaining Message authentication code
CSC	Cypress Serial Control
CTS	Clear to Send
DMA	direct memory access
DSSS	Direct Sequence Spread Spectrum
EIR	Extended inquiry response
EPR	Encryption pause resume
eSCO	Extended synchronous connections
HCI	Host Control Interface
IRQ	interrupt request
JTAG	Joint Test Action Group
LCU	link control unit

Term	Description
LDO	low drop-out
LST	Link supervision timeout
MIB	Management Information Base
OFDM	Orthogonal Frequency Division Multiplexing
PDM	pulse density modulation
PLL	phase locked loop
POR	power-on reset
RTS	Request to Send
RX/TX	receive, transmit
SDIO	Secure Digital Input Output
SPI	serial peripheral interface
SSP	Secure simple pairing
SSR	Sniff subrating
SWD	serial wire debug
TXOP	Transmit Opportunity
UART	universal asynchronous receiver/transmitter
WD	watchdog
WEP	wired equivalent privacy
QoS	Quality of Service

24.2 References

The references in this section may be used in conjunction with this document.

Note: Cypress provides customer access to technical documentation and software through its Customer Support Portal (CSP) and Downloads & Support site (see [IoT Resources](#)).

	Document (or Item) Name	Number	Source
[1]	Bluetooth MWS Coexistence 2-wire Transport Interface Specification	–	Wiced-bluetooth

24.3 IoT Resources

Cypress provides a wealth of data at <http://www.cypress.com/internet-things-iot> to help you to select the right IoT device for your design, and quickly and effectively integrate the device into your design. Cypress provides customer access to a wide range of information, including technical documentation, schematic diagrams, product bill of materials, PCB layout information, and software updates. Customers can acquire technical documentation and software from the Cypress Support Community website (<https://community.cypress.com/>)

24.4 Errata

- From Rev *D onwards BT_GPIO_4 (Pad H5 on the 128 ball WLPGA package) has been designated as a VSSC i.e. must be shorted to Ground on the PCB. This is to reduce leakage current and meet the current specifications in the datasheet. Cypress does not guarantee datasheet specifications when using CYW4373 without this pad being shorted to ground. When BT_GPIO_4 is connected to ground there will be a small leakage current momentarily when the chip exits reset with BT_REG_ON pulled high due to the default internal pull up on this pin. This leakage stops post BT firmware download because the BT firmware disables the pull up and enables a pull down on BT_GPIO_4.
- From Rev *D onwards the section describing SPI interface for Bluetooth has been removed from the datasheet. The CYW4373 does not support SPI as a Bluetooth HCI transport interface. The SPI sections in the datasheet were a carryover from legacy documents and incorrectly included. UART and USB are the Bluetooth HCI transport interfaces supported by CYW4373.

Document History

Document Title: CYW4373 Single-Chip Dual Band WiFi IEEE 802.11 a/b/g/n/ac MAC/Baseband/Radio with Integrated Bluetooth 5.0			
Document Number: 002-18123			
Revision	ECN	Submission Date	Description of Change
**	5553562	12/15/2016	New datasheet
*A	5632270	02/16/2017	<p>Removed Package Thermal Characteristics table from section 21.1</p> <p>Updated the package diagram Figure 49 and Figure 50 with latest information</p> <p>Added "Absolute Junction Temperature limits are maintained through active thermal monitoring and driver-based techniques that may include duty-cycle limiting or turning off one of the TX chains, or both" in the Section 22. Thermal Specification under the 22.1.1 Summary on page 113.</p> <p>Figure 31: Swapped USB2_DP and USB2_DM</p> <p>Replaced the following in Table 16 on page 55:</p> <p>B9: Changed PCIE_LCKREQ_L with PCIE_CLKREQ_L</p> <p>F1/G1: Swapped USB2_DP with USB2_DM</p> <p>L2: replaced VSSC with BT_DEV_WAKE</p> <p>L3: replace BT_HOST_WAKE with BT_PCM_OUT</p> <p>Updated Table 25: "Ambient Temperature" value- "-20 to +70".</p> <p>Updated "Minimum ESD Rating" values in Table 26.</p> <p>Clarified Table 29 general parameter description</p> <p>Removed unit for parameter "Mod Char: ratio" in Table 30</p> <p>Updated Table 38, Table 39, Table 40, Table 41 and Table 42 based on latest data.</p> <p>Removed notes above/below these tables.</p> <p>Updated Table 71 "Operating Ambient Temperature" to -20°C to 70°C.</p>
*B	5711109	04/28/2017	<p>Updated Table 2, Table 48 and Table 49.</p> <p>Changed "2G_WL_TX" to "2G_WL_RX" in Figure 1</p> <p>Removed MCS8, MCS9 from Table 32, Table 33.</p> <p>Removed 3.3 Frequency Selection.</p> <p>Changed the entire row MCS to MCS NSS1 in Table 34.</p> <p>Removed the Section 22. Thermal Specification</p> <p>Removed PCIe from Figure 1, Figure 2 and Figure 3</p> <p>Removed 9.1 PCI Express Interface and 19.2 PCI Express Interface Parameters.</p> <p>Replaced Ball Map -Figure 32.</p>

Document Title: CYW4373 Single-Chip Dual Band WiFi IEEE 802.11 a/b/g/n/ac MAC/Baseband/Radio with Integrated Bluetooth 5.0 Document Number: 002-18123			
*C	5846244	08/16/2017	<p>Updated 8.4.1 LTE Coexistence Interface on page 41 and added the Note:</p> <p>a. GPIO_2, GPIO_3, GPIO_4, GPIO_5 and GPIO_6 are multiplexed with the JTAG interface using the JTAG_SEL pin.</p> <p>b. The 2- and 3-wire coexistence interfaces are not supported by default on the CYW94373WLSUSB reference design. Please contact the Cypress support team to understand how to use these interfaces.</p> <p>Replaced the Figure 32 on page 54 with "Pinout mod for PCIe_v3.pdf".</p> <p>Updated Table 17 on page 55.</p> <p>Replaced A7, A8, A9, A10, B9, B11, C11 and D8 with NC.</p> <p>Changed the title to "Single-Chip Dual Band WiFi IEEE 802.11 a/b/g/n/ac MAC/Baseband/Radio with Integrated Bluetooth 5.0"</p> <p>Changed "Handheld devices" to "IoT and embedded device" throughout the document.</p> <p>Updated Figure 3 on page 8: Removed Core0.</p> <p>Added Section 7.3 I²S Interface on page 36.</p> <p>Updated Figure 30, Table 27, Table 30, Table 32, Table 34, Table 35, Table 40, Table 41, Table 48, Table 49.</p>
*D	5985593	12/06/2017	<p>Updated Figure 1 on page 2.</p> <p>Replaced BT_GPIO 4 to VSSC throughout the datasheet.</p> <p>Updated Table 19 on page 61 and Table 50 on page 95</p> <p>Replaced Figure 33.</p> <p>Updated Typical value in Table 33 on page 79</p> <p>Replaced 5.25 Max value to 4.8 in Table 43, Table 44 and Table 45.</p> <p>Added HLDO and Errata sections.</p> <p>Updated the contents in the Table 32, Table 33, Table 34, Table 35.</p> <p>Upgraded Bluetooth 4.2 to Bluetooth 5.0 throughout the datasheet.</p> <p>Updated "PMU_VDDIO" to "PMU BT_VDDIO" in Figure 3: "Typical Power Topology (Page 1 of 2)," on page 8.</p> <p>Added 5.1 Bluetooth 5.0 Features on page 19.</p> <p>Added NOTE: The table below is intended to explain functionality and may not provide all the details necessary for designing a board using CYW4373 (for e.g. the decoupling capacitors necessary). Refer to Cypress's CYW94373WLSUSB reference design and consult Cypress technical support teams for design reviews" above Table 18 on page 57 and updated the table contents.</p> <p>Updated Table 24 on page 67.</p> <p>Updated 23. Ordering Information on page 110.</p> <p>Updated Table 18: Integrated Voltage Regulators - Type column data to "PWR".</p> <p>Added "T" to the Part Numbers in the 23. Ordering Information on page 110.</p>
*E	6114282	03/29/2018	<p>Updated Overview section.</p> <p>Updated Figure 2.</p> <p>Updated the Max, Typ and Min values in Table 26, Table 29, Table 32, Table 33, Table 34, Table 37, Table 38, Table 39, Table 40, Table 41, Table 48, and Table 49.</p> <p>Updated Conditions/ Notes and added footnote "With Full channel estimation ON -improved by 1.5-2dBm" in Table 35.</p> <p>Deleted the section SWD Timing.</p>

Document Title: CYW4373 Single-Chip Dual Band WiFi IEEE 802.11 a/b/g/n/ac MAC/Baseband/Radio with Integrated Bluetooth 5.0			
Document Number: 002-18123			
*F	6222890	07/12/2018	Removed "256-QAM" from Table 33 . Table 33 and Table 35 : Updated "Carrier Suppression". Table 48 and Table 49 : Added a row "Peak PHY Calibration Current". Updated "Quiescent current" values in Table 43 , Table 44 , Table 45 , Table 46 and Table 47 . Added Acronyms and Abbreviations table.
*G	7108629	03/22/2021	Updated Features and IEEE 802.11ac PHY section. Updated Table 32 and Table 34 .

Sales, Solutions, and Legal Information

Worldwide Sales and Design Support

Cypress maintains a worldwide network of offices, solution centers, manufacturer's representatives, and distributors. To find the office closest to you, visit us at [Cypress Locations](#).

Products

Arm [®] Cortex [®] Microcontrollers	cypress.com/arm
Automotive	cypress.com/automotive
Clocks & Buffers	cypress.com/clocks
Interface	cypress.com/interface
Internet of Things	cypress.com/iot
Memory	cypress.com/memory
Microcontrollers	cypress.com/mcu
PSoC	cypress.com/psoc
Power Management ICs	cypress.com/pmic
Touch Sensing	cypress.com/touch
USB Controllers	cypress.com/usb
Wireless Connectivity	cypress.com/wireless

PSoC[®] Solutions

[PSoC 1](#) | [PSoC 3](#) | [PSoC 4](#) | [PSoC 5LP](#) | [PSoC 6 MCU](#)

Cypress Developer Community

[Community](#) | [Projects](#) | [Video](#) | [Blogs](#) | [Training](#) | [Components](#)

Technical Support

cypress.com/support

© Cypress Semiconductor Corporation, 2016-2021. This document is the property of Cypress Semiconductor Corporation, and Infineon Technologies company, and its affiliates ("Cypress"). This document, including any software or firmware included or referenced in this document ("Software"), is owned by Cypress under the intellectual property laws and treaties of the United States and other countries worldwide. Cypress reserves all rights under such laws and treaties and does not, except as specifically stated in this paragraph, grant any license under its patents, copyrights, trademarks, or other intellectual property rights. If the Software is not accompanied by a license agreement and you do not otherwise have a written agreement with Cypress governing the use of the Software, then Cypress hereby grants you a personal, non-exclusive, nontransferable license (without the right to sublicense) (1) under its copyright rights in the Software (a) for Software provided in source code form, to modify and reproduce the Software solely for use with Cypress hardware products, only internally within your organization, and (b) to distribute the Software in binary code form externally to end users (either directly or indirectly through resellers and distributors), solely for use on Cypress hardware product units, and (2) under those claims of Cypress's patents that are infringed by the Software (as provided by Cypress, unmodified) to make, use, distribute, and import the Software solely for use with Cypress hardware products. Any other use, reproduction, modification, translation, or compilation of the Software is prohibited.

TO THE EXTENT PERMITTED BY APPLICABLE LAW, CYPRESS MAKES NO WARRANTY OF ANY KIND, EXPRESS OR IMPLIED, WITH REGARD TO THIS DOCUMENT OR ANY SOFTWARE OR ACCOMPANYING HARDWARE, INCLUDING, BUT NOT LIMITED TO, THE IMPLIED WARRANTIES OF MERCHANTABILITY AND FITNESS FOR A PARTICULAR PURPOSE. No computing device can be absolutely secure. Therefore, despite security measures implemented in Cypress hardware or software products, Cypress shall have no liability arising out of any security breach, such as unauthorized access to or use of a Cypress product. CYPRESS DOES NOT REPRESENT, WARRANT, OR GUARANTEE THAT CYPRESS PRODUCTS, OR SYSTEMS CREATED USING CYPRESS PRODUCTS, WILL BE FREE FROM CORRUPTION, ATTACK, VIRUSES, INTERFERENCE, HACKING, DATA LOSS OR THEFT, OR OTHER SECURITY INTRUSION (collectively, "Security Breach"). Cypress disclaims any liability relating to any Security Breach, and you shall and hereby do release Cypress from any claim, damage, or other liability arising from any Security Breach. In addition, the products described in these materials may contain design defects or errors known as errata which may cause the product to deviate from published specifications. To the extent permitted by applicable law, Cypress reserves the right to make changes to this document without further notice. Cypress does not assume any liability arising out of the application or use of any product or circuit described in this document. Any information provided in this document, including any sample design information or programming code, is provided only for reference purposes. It is the responsibility of the user of this document to properly design, program, and test the functionality and safety of any application made of this information and any resulting product. "High-Risk Device" means any device or system whose failure could cause personal injury, death, or property damage. Examples of High-Risk Devices are weapons, nuclear installations, surgical implants, and other medical devices. "Critical Component" means any component of a High-Risk Device whose failure to perform can be reasonably expected to cause, directly or indirectly, the failure of the High-Risk Device, or to affect its safety or effectiveness. Cypress is not liable, in whole or in part, and you shall and hereby do release Cypress from any claim, damage, or other liability arising from any use of a Cypress product as a Critical Component in a High-Risk Device. You shall indemnify and hold Cypress, including its affiliates, and its directors, officers, employees, agents, distributors, and assigns harmless from and against all claims, costs, damages, and expenses, arising out of any claim, including claims for product liability, personal injury or death, or property damage arising from any use of a Cypress product as a Critical Component in a High-Risk Device. Cypress products are not intended or authorized for use as a Critical Component in any High-Risk Device except to the limited extent that (i) Cypress's published data sheet for the product explicitly states Cypress has qualified the product for use in a specific High-Risk Device, or (ii) Cypress has given you advance written authorization to use the product as a Critical Component in the specific High-Risk Device and you have signed a separate indemnification agreement.

Cypress, the Cypress logo, and combinations thereof, WICED, ModusToolBox, PSoC, CapSense, EZ-USB, F-RAM, and Traveo are trademarks or registered trademarks of Cypress or a subsidiary of Cypress in the United States or in other countries. For a more complete list of Cypress trademarks, visit cypress.com. Other names and brands may be claimed as property of their respective owners.

Looking for pricing, stock, or lifecycle information?

Click below to explore more details on WIN SOURCE:

 [View CYW4373EUBGT on WIN SOURCE](#)

 [Infineon Technologies](#) Information

Optimize Your Supply Chain with WIN SOURCE Solutions

-  Global Sourcing Solution
-  Obsolete Management
-  Cost Control Management
-  Shortage Management
-  Alternative Solution
-  Excess Inventory Management