

BQ77207 Voltage and Temperature Protection for 3-Series to 7-Series Cell Li-Ion Batteries with Internal Delay Timer

1 Features

- 3-series cell to 7-series cell protection
- High-accuracy overvoltage protection
 - ± 10 mV at 25°C
 - ± 20 mV from 0°C to 60°C
- Overvoltage protection options from 3.55 V to 5.1 V
- Undervoltage protection with options from 1.0 V to 3.5 V
- Open-wire connection detection
- Overtemperature protection using NTC or PTC
- Random cell connection
- Functional safety-capable
- Fixed internal delay timers
- Fixed detections thresholds
- Fixed output drive type for each of COUT and DOUT
 - Active high or active low
 - Active high drive to 6 V
 - Open drain with ability to be pulled up externally to VDD
- Low power consumption $I_{CC} \approx 1 \mu\text{A}$ ($V_{\text{CELL(ALL)}} < V_{\text{OV}}$)
- Low leakage current per cell input < 100 nA with open-wire detection disabled
- Package footprint option
 - 12-pin WSON with 0.5-mm lead pitch

2 Applications

- Protection for Li-ion battery packs used in:
 - [Handheld garden tools](#)
 - [Handheld power tools](#)
 - [Cordless vacuum cleaners](#)
 - [UPS battery backup](#)
 - [Light electric vehicles \(eBike, eScooter, pedal assist bicycles\)](#)

3 Description

The BQ77207 family of products provides a range of voltage and temperature monitoring including overvoltage (OVP), undervoltage (UVP), open wire (OW), and overtemperature (OT) protection for Li-ion battery pack systems. Each cell is monitored independently for overvoltage, undervoltage, and open-wire conditions. With the addition of an external NTC or PTC thermistor, the device can detect overtemperature conditions.

In the BQ77207 device, an internal delay timer is initiated upon detection of an overvoltage, undervoltage, open-wire, or overtemperature condition. Upon expiration of the delay timer, the respective output is triggered into its active state (either high or low, depending on the configuration).

Device Information Table

| PART NUMBER | PACKAGE ⁽¹⁾ | BODY SIZE (NOM) |
|-------------|------------------------|-----------------|
| BQ7720700 | WSON (12) | 3.0 mm × 2.0 mm |

- (1) For available catalog packages, see the orderable addendum at the end of the data sheet and the [Device Comparison Table](#).

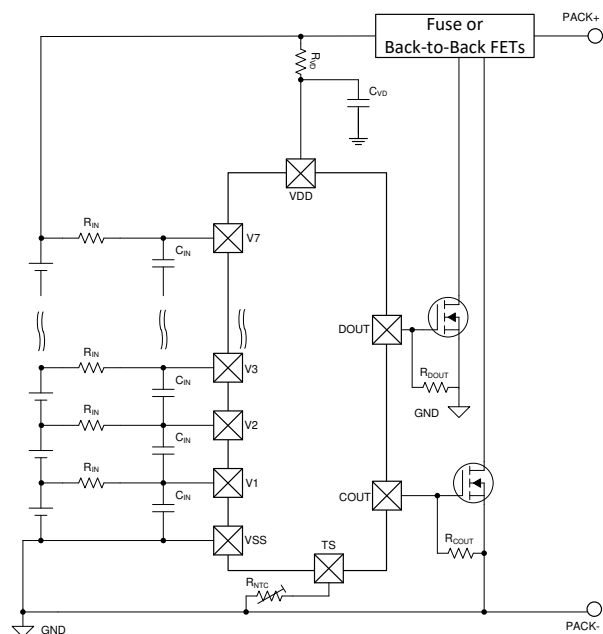

Simplified Schematic



Table of Contents

| | | | |
|--|---|--|----|
| 1 Features | 1 | 9.4 Device Functional Modes..... | 10 |
| 2 Applications | 1 | 10 Application and Implementation | 12 |
| 3 Description | 1 | 10.1 Application Information..... | 12 |
| 4 Revision History | 2 | 10.2 Systems Example..... | 14 |
| 5 Description (continued) | 3 | 11 Power Supply Recommendations | 15 |
| 6 Device Comparison Table | 3 | 12 Layout | 16 |
| 7 Pin Configuration and Functions | 3 | 12.1 Layout Guidelines..... | 16 |
| 8 Specifications | 4 | 12.2 Layout Example..... | 16 |
| 8.1 Absolute Maximum Ratings..... | 4 | 13 Device and Documentation Support | 17 |
| 8.2 ESD Ratings..... | 4 | 13.1 Third-Party Products Disclaimer..... | 17 |
| 8.3 Recommended Operating Conditions..... | 4 | 13.2 Receiving Notification of Documentation Updates.. | 17 |
| 8.4 Thermal Information..... | 4 | 13.3 Support Resources..... | 17 |
| 8.5 DC Characteristics..... | 5 | 13.4 Trademarks..... | 17 |
| 8.6 Timing Requirements..... | 7 | 13.5 Electrostatic Discharge Caution..... | 17 |
| 9 Detailed Description | 8 | 13.6 Glossary..... | 17 |
| 9.1 Overview..... | 8 | 14 Mechanical, Packaging, and Orderable Information | 17 |
| 9.2 Functional Block Diagram..... | 8 | | |
| 9.3 Feature Description..... | 8 | | |

4 Revision History

NOTE: Page numbers for previous revisions may differ from page numbers in the current version.

| Changes from Revision * (December 2021) to Revision A (June 2022) | Page |
|---|-------------|
| • Added the BQ7720701 and BQ7720702 devices to Section 6 ; added the OVP and UVP output delays..... | 3 |

5 Description (continued)

The overvoltage triggers the COUT pin if a fault is detected, and undervoltage triggers the DOUT pin if a fault is detected. If an overtemperature or open-wire fault is detected, then both the DOUT and COUT will be triggered. For quicker production-line testing, the BQ77207 device provides a Customer Test Mode (CTM) with greatly reduced delay time.

6 Device Comparison Table

| PART NUMBER ⁽¹⁾ | T _A | PACKAGE | PACKAGE DESIGNATOR | OVP (V) | OV HYSTERESIS (V) | OVP OUTPUT DELAY | UVP (V) |
|----------------------------|----------------|-------------|--------------------|---------|-------------------|------------------|---------|
| BQ7720700 | –40°C to 110°C | 12-Pin WSON | DSS | 4.325 | 0.100 | 1 s | 2.25 |
| BQ7720701 | –40°C to 110°C | 12-Pin WSON | DSS | 4.275 | 0.100 | 1 s | 2 |
| BQ7720702 | –40°C to 110°C | 12-Pin WSON | DSS | 4.275 | 0.100 | 4 s | 2 |

| PART NUMBER (CONT.) ⁽¹⁾ | UV HYSTERESIS (V) | UVP OUTPUT DELAY | OT (°C) | OW | LATCH | OUTPUT DRIVE | TAPE AND REEL |
|------------------------------------|-------------------|------------------|---------|---------|----------|-----------------|---------------|
| BQ7720700 | 0.100 | 1 s | 70 | Enabled | Disabled | Active High 6 V | BQ7720700DSSR |
| BQ7720701 | 0.100 | 1 s | 80 | Enabled | Disabled | Active High 6 V | BQ7720701DSSR |
| BQ7720702 | 0.100 | 2 s | 80 | Enabled | Disabled | Active High 6 V | BQ7720702DSSR |

(1) For future options, contact TI for more information.

7 Pin Configuration and Functions

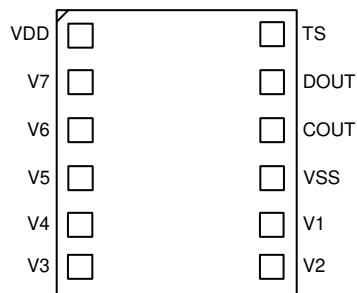

Figure 7-1. BQ77207 Pin Diagram

12-Pin Functions

| NO. | NAME | TYPE ⁽¹⁾ | DESCRIPTION |
|-----|------|---------------------|---|
| 1 | VDD | P | Power supply |
| 2 | V7 | I | Sense input for positive voltage of the seventh cell from the bottom of the stack |
| 3 | V6 | I | Sense input for positive voltage of the sixth cell from the bottom of the stack |
| 4 | V5 | I | Sense input for positive voltage of the fifth cell from the bottom of the stack |
| 5 | V4 | I | Sense input for positive voltage of the fourth cell from the bottom of the stack |
| 6 | V3 | I | Sense input for positive voltage of the third cell from the bottom of the stack |
| 7 | V2 | I | Sense input for positive voltage of the second cell from the bottom of the stack |
| 8 | V1 | I | Sense input for positive voltage of the first cell from the bottom of the stack |
| 9 | VSS | P | Electrically connected to IC ground and negative terminal of the lowest cell in the stack |
| 10 | COUT | O | Output drive for overvoltage, open wire, and overtemperature. It can be left floating if not used. |
| 11 | DOUT | O | Output drive for undervoltage, open wire, and overtemperature. It can be left floating if not used. |
| 12 | TS | I | Temperature sensor input. If not used, leave it NC. |

(1) I = Input, O = Output, P = Power Connection

8 Specifications

8.1 Absolute Maximum Ratings

over operating free-air temperature range (unless otherwise noted)⁽¹⁾

| | | MIN | MAX | UNIT |
|---|---------------------------|------|-----|------|
| Supply voltage range | VDD - VSS ⁽²⁾ | -0.3 | 45 | V |
| Input voltage range | Vn - VSS where n = 1 to 7 | -0.3 | 45 | V |
| | TS | -0.3 | 1.5 | V |
| Output voltage range | COUT - VSS, DOUT - VSS | -0.3 | 45 | V |
| Functional temperature, T _{FUNC} | | -40 | 110 | °C |
| Storage temperature, T _{STG} | | -65 | 150 | °C |

- (1) Operation outside the Absolute Maximum Ratings may cause permanent device damage. Absolute Maximum Ratings do not imply functional operation of the device at these or any other conditions beyond those listed under Recommended Operating Conditions. If outside the Recommended Operating Conditions but within the Absolute Maximum Ratings, the device may not be fully functional, and this may affect device reliability, functionality, performance, and shorten the device lifetime.
- (2) DC Voltage applied on this pin should be limited to a maximum of 40 V. Stresses to this pin at voltages beyond this level, up to the 45-V specified maximum level, should be limited to short transients.

8.2 ESD Ratings

| | | | VALUE | UNIT |
|--------------------|-------------------------|--|-------|------|
| V _(ESD) | Electrostatic discharge | Human body model (HBM), per ANSI/ESDA/ JEDEC JS-001, all pins ⁽¹⁾ | ±2000 | V |
| | | Charged device model (CDM), per ANSI/ESDA/ JEDEC JS-002, all pins, all pins ⁽²⁾ | ±500 | |

- (1) JEDEC document JEP155 states that 500-V HBM allows safe manufacturing with a standard ESD control process.
- (2) JEDEC document JEP157 states that 250-V CDM allows safe manufacturing with a standard ESD control process.

8.3 Recommended Operating Conditions

over operating free-air temperature range (unless otherwise noted)

| | | MIN | NOM | MAX | UNIT |
|------------------|--|-----|-----|------|------|
| V _{DD} | Supply voltage ⁽¹⁾ | 5 | | 38.5 | V |
| V _{IN} | Input voltage range of Vn - Vn-1 where n = 2 to 7 and V1 - VSS | 0 | | 5 | V |
| | TS | 0 | | 1.5 | V |
| V _{CTM} | Customer Test Mode Entry V _{DD} > V7 + V _{CTM} | 12 | | 13 | V |
| C _{TS} | Total capacitance on the TS Pin | | | 200 | pF |
| T _A | Ambient temperature | -40 | | 85 | °C |
| T _J | Junction temperature | -65 | | 150 | °C |

- (1) V_{DD} is equal to top of stack voltage.

8.4 Thermal Information

| THERMAL METRIC ⁽¹⁾ | | DEVICE | UNIT |
|-------------------------------|--|---------|------|
| | | DSS | |
| | | 12 PINS | |
| R _{θJA} | Junction-to-ambient thermal resistance | 67.3 | °C/W |
| R _{θJC(top)} | Junction-to-case (top) thermal resistance | 68.6 | °C/W |
| R _{θJB} | Junction-to-board thermal resistance | 35.9 | °C/W |
| Ψ _{JT} | Junction-to-top characterization parameter | 2.9 | °C/W |
| Ψ _{JB} | Junction-to-board characterization parameter | 35.9 | °C/W |

8.4 Thermal Information (continued)

| THERMAL METRIC ⁽¹⁾ | | DEVICE | UNIT |
|-------------------------------|--|---------|------|
| | | DSS | |
| | | 12 PINS | |
| R _{θJC(bot)} | Junction-to-case (bottom) thermal resistance | 14 | °C/W |

(1) For more information about traditional and new thermal metrics, see the [Semiconductor and IC Package Thermal Metrics](#) application report.

8.5 DC Characteristics

Typical values stated where T_A = 25°C and VDD = 25 V, MIN/MAX values stated where T_A = –40°C to 85°C and VDD = 5 V to 38.5 V (unless otherwise noted).

| PARAMETER | | TEST CONDITIONS | MIN | TYP | MAX | UNIT |
|---|--------------------------------------|--|-----------------------|--------|------|------|
| OVER VOLTAGE PROTECTION (OV) | | | | | | |
| V _{OV} | OV Detection Range | | 3.55 | | 5.1 | V |
| V _{OV_STEP} | OV Detection Steps | | | 25 | | mV |
| V _{OV_HYS} | OV Detection Hysteresis | Selected OV Hysteresis depends on part number. See device selection table for details. | V _{OV} – 50 | | | mV |
| | | Selected OV Hysteresis depends on part number. See device selection table for details. | V _{OV} – 100 | | | mV |
| V _{OV_ACC} | OV Detection Accuracy | T _A = 25°C | –10 | | 10 | mV |
| | OV Detection Accuracy | 0°C ≤ T _A ≤ 60°C | –20 | | 20 | mV |
| | OV Detection Accuracy | –40°C ≤ T _A ≤ 110°C | –50 | | 50 | mV |
| UNDER VOLTAGE PROTECTION (UV) | | | | | | |
| V _{UV} | UV Detection Range | | 1.0 | | 3.5 | V |
| V _{UV_STEP} | UV Detection Steps | | | 50 | | mV |
| V _{UV_HYS} | UV Detection Hysteresis | Selected UV Hysteresis depends on part number. See device selection table for details. | V _{UV} + 50 | | | mV |
| | | Selected UV Hysteresis depends on part number. See device selection table for details. | V _{UV} + 100 | | | mV |
| V _{UV_ACC} | UV Detection Accuracy | T _A = 25°C | –30 | | 30 | mV |
| | UV Detection Accuracy | –40 ≤ T _A ≤ 110°C | –50 | | 50 | mV |
| V _{UV_MIN} | UV Detection Disabled Threshold | V _n - V _{n-1} where n = 2 to 7 and V1 - VSS | 450 | 500 | 550 | mV |
| OVER TEMPERATURE PROTECTION (OT) | | | | | | |
| T _{OT} | OT Detection Range | Available options: 62°C, 65°C, 70°C, 75°C, 80°C, 83°C | 62.0 | | 83.0 | °C |
| R _{OT_EXT_NTC} | NTC OT Detection External Resistance | | | 2850 | | Ω |
| | | | | 2570 | | |
| | | | | 2195 | | |
| | | | | 1915 | | |
| | | | | 1651 | | |
| | | | | 1525 | | |
| R _{OT_EXT_PTC} | PTC OT Detection External Resistance | | | 111100 | | Ω |

8.5 DC Characteristics (continued)

Typical values stated where $T_A = 25^\circ\text{C}$ and $V_{DD} = 25\text{ V}$, MIN/MAX values stated where $T_A = -40^\circ\text{C}$ to 85°C and $V_{DD} = 5\text{ V}$ to 38.5 V (unless otherwise noted).

| PARAMETER | | TEST CONDITIONS | MIN | TYP | MAX | UNIT |
|--|--|---|-------|----------------|------|------------------|
| $T_{OT_ACC}^{(1)}$ | OT Detection Accuracy (NTC) | | -5 | | 5 | $^\circ\text{C}$ |
| $T_{OT_HYS}^{(2)}$ | OT Detection Hysteresis (NTC) | | | -10 | | $^\circ\text{C}$ |
| | | | | 4186 | | Ω |
| | | | | 3530 | | Ω |
| R_{TC} | Internal Pull Up Resistor | After TI Factory Trim | 19.4 | 20 | 20.6 | k Ω |
| UNDER TEMPERATURE PROTECTION (UT) | | | | | | |
| T_{UT} | UT Detection Threshold | | -30.0 | | 0.0 | $^\circ\text{C}$ |
| $R_{UT_EXT_NTC}$ | NTC UT Detection External Resistance | | | 111100 | | Ω |
| | | | | 68900 | | |
| | | | | 42200 | | |
| | | | | 26700 | | |
| R_{UT_ACC} | UT Detection External Resistance Accuracy | | -2% | | 2% | |
| T_{UT_HYS} | UT Detection Hysteresis (NTC) | | | 10 | | $^\circ\text{C}$ |
| | | | | 17800 | | Ω |
| $T_{UT_ACC}^{(1)}$ | UT Detection Accuracy (NTC) | | -5 | | 5 | $^\circ\text{C}$ |
| OPEN WIRE PROTECTION (OW) | | | | | | |
| V_{OW} | OW Detection Threshold | $V_n < V_{n-1}$ where $n = 2$ to 7 | | -200 | | mV |
| | | $V_1 - V_{SS}$ | | 500 | | mV |
| V_{OW_HYS} | OW Detection Hysteresis | $V_n < V_{n-1}$ where $n = 1$ to 7 | | $V_{OW} + 100$ | | mV |
| V_{OW_ACC} | OW Detection Accuracy | $-40^\circ\text{C} \leq T_A \leq 110^\circ\text{C}$ | -25 | | 25 | mV |
| SUPPLY AND LEAKAGE CURRENT | | | | | | |
| I_{CC} | Supply Current | No fault detected. | | 2 | 3.5 | μA |
| I_{CC_FAULT} | Supply Current | Fault detected, COUT active High 6V output, DOUT active low. Other faults | | 20 | 25 | μA |
| I_{CC_FAULT} | Supply Current | Fault detected, COUT active High 6V output, DOUT active low. UV fault only | | 3 | 5 | μA |
| $I_{IN}^{(2)}$ | Input Current at V_x Pins | $V_n - V_{n-1}$ and $V_1 - V_{SS} = 4\text{V}$, where $n = 2$ to 7 , Open Wire Enabled | -0.3 | | 0.3 | μA |
| | | $V_n - V_{n-1}$ and $V_1 - V_{SS} = 4\text{V}$, where $n = 2$ to 7 , Open Wire Disabled | -0.1 | | 0.1 | μA |
| OUTPUT DRIVE, COUT and DOUT, CMOS ACTIVE HIGH VERSIONS ONLY | | | | | | |
| V_{OUT_AH} | Output Drive Voltage for COUT and DOUT, Active High 6V | $V_n - V_{n-1}$ or $V_1 - V_{SS} > V_{OV}$, where $n = 2$ to 7 , $V_{DD} = 25\text{V}$, $I_{OH} = 100\ \mu\text{A}$ measured out of COUT, DOUT pin. | 6 | | | V |
| | Output Drive Voltage for COUT and DOUT, Active High VDD | $V_{DD} - V_{COUT}$ or V_{DOUT} , $V_n - V_{n-1}$ or $V_1 - V_{SS} > V_{OV}$, where $n = 2$ to 7 , $I_{OH} = 10\ \mu\text{A}$ measured out of COUT, DOUT pin. | 0 | 1 | 1.5 | V |
| | Output Drive Voltage for COUT and DOUT, Active High 6V | $V_{DD} - V_{COUT}$ or V_{DOUT} . If 6 of 7 cells are short circuited and only one cell remains powered and $> V_{OV}$, $V_{DD} = V_x$ (cell voltage), $I_{OH} = 100\ \mu\text{A}$. | 0 | 1 | 1.5 | V |
| | Output Drive Voltage for COUT and DOUT, Active High 6V and VDD | $V_n - V_{n-1}$ and $V_1 - V_{SS} < V_{OV}$, where $n = 2$ to 7 , $V_{DD} = 25\text{ V}$, $I_{OH} = 100\ \mu\text{A}$ measured into pin | | 250 | 400 | mV |
| R_{OUT_AH} | Internal Pull Up Resistor | | 80 | 100 | 120 | k Ω |

8.5 DC Characteristics (continued)

Typical values stated where $T_A = 25^\circ\text{C}$ and $V_{DD} = 25\text{ V}$, MIN/MAX values stated where $T_A = -40^\circ\text{C}$ to 85°C and $V_{DD} = 5\text{ V}$ to 38.5 V (unless otherwise noted).

| PARAMETER | | TEST CONDITIONS | MIN | TYP | MAX | UNIT |
|---|--|--|-----|-----|-----|------|
| $I_{\text{OUT_AH_H}}$ | OUT Source Current (during OV) | $V_n - V_{n-1}$ or $V_1 - V_{SS} > V_{\text{OV}}$, where $n = 2$ to 7 , $V_{DD} = 25\text{ V}$, $\text{OUT} = 0\text{V}$. Measured out of COUT, DOUT pin | | | 6.5 | mA |
| $I_{\text{OUT_AH_L}}$ | OUT Sink Current (no OV) | $V_n - V_{n-1}$ and $V_1 - V_{SS} < V_{\text{OV}}$, where $n = 2$ to 7 , $V_{DD} = 25\text{ V}$, $\text{OUT} = V_{DD}$. Measured into COUT, DOUT pin | 0.3 | | 3 | mA |
| OUTPUT DRIVE, COUT and DOUT, NCH OPEN DRAIN ACTIVE LOW VERSIONS ONLY | | | | | | |
| $V_{\text{OUT_AL}}$ | Output Drive Voltage for COUT and DOUT, Active Low | $V_n - V_{n-1}$ or $V_1 - V_{SS} > V_{\text{OV}}$, where $n = 2$ to 7 , $V_{DD} = 25\text{ V}$, $I_{\text{OH}} = 100\ \mu\text{A}$ measured into COUT, DOUT pin. | | 250 | 400 | mV |
| $I_{\text{OUT_AL_L}}$ | OUT Source Current (during OV) | $V_n - V_{n-1}$ or $V_1 - V_{SS} > V_{\text{OV}}$, where $n = 2$ to 7 , $V_{DD} = 25\text{ V}$, $\text{OUT} = V_{DD}$. Measured into COUT, DOUT pin. | 0.3 | | 3 | mA |
| $I_{\text{OUT_AL_H}}$ | OUT Sink Current (no OV) | $V_n - V_{n-1}$ and $V_1 - V_{SS} < V_{\text{OV}}$, where $n = 2$ to 7 , $V_{DD} = 25\text{ V}$, $\text{OUT} = V_{DD}$. Measured out of COUT, DOUT pin. | | | 100 | nA |

- (1) Assured by design. This accuracy assumes the external resistance is within $\pm 2\%$ of the $R_{\text{OT_EXT}}$ values for the corresponding temperature threshold.
- (2) Assured by design

8.6 Timing Requirements

Typical values stated where $T_A = 25^\circ\text{C}$ and $V_{DD} = 25\text{ V}$, MIN/MAX values stated where $T_A = -40^\circ\text{C}$ to 85°C and $V_{DD} = 5\text{ V}$ to 38.5 V (unless otherwise noted).

| PARAMETER | | TEST CONDITIONS | MIN | TYP | MAX | UNIT |
|-------------------------|--|--|------|------|-----|------|
| $t_{\text{OV_DELAY}}$ | OV Delay Time | | | 0.25 | | s |
| | | | | 0.5 | | s |
| | | | | 1 | | s |
| | | | | 2 | | s |
| | | | | 4 | | s |
| $t_{\text{UV_DELAY}}$ | UV Delay Time | | | 0.25 | | s |
| | | | | 0.5 | | s |
| | | | | 1 | | s |
| | | | | 2 | | s |
| $t_{\text{OT_DELAY}}$ | OT Delay Time | | | 4 | | s |
| $t_{\text{OW_DELAY}}$ | OW Delay Time | | | 4 | | s |
| $t_{\text{DELAY_ACC}}$ | Delay Time Accuracy | For 0.25s, 0.5s delays | -128 | | 128 | ms |
| $t_{\text{DELAY_ACC}}$ | Delay Time Accuracy | For 1s delays | -150 | | 150 | ms |
| $t_{\text{DELAY_DR}}$ | Delay time drift across operating temp | For all delays other than 0.25s, 0.5s, 1s delays | -10% | | 10% | |
| $t_{\text{CTM_DELAY}}$ | Fault Detection Delay Time during Customer Test Mode | See Customer Test Mode. | | 50 | | ms |

9 Detailed Description

9.1 Overview

The BQ77207 family of devices provides a range of voltage and temperature monitoring including overvoltage (OVP), undervoltage (UVP), open wire (OW), and overtemperature (OT) protection for Li-ion battery pack systems. Each cell is monitored independently for overvoltage, undervoltage, and open-wire conditions. With the addition of an external NTC thermistor, the device can detect overtemperature conditions. An internal delay timer is initiated upon detection of an overvoltage, undervoltage, open-wire, or overtemperature condition. Upon expiration of the delay timer, the respective output is triggered into its active state (either high or low depending on the configuration). The overvoltage triggers the COUT pin if a fault is detected, and undervoltage triggers the DOUT pin if a fault is detected. If an undertemperature, overtemperature, or open-wire fault is detected, then both the DOUT and COUT are triggered.

For quicker production-line testing, the BQ77207 device provides a Customer Test Mode (CTM) with greatly reduced delay time.

9.2 Functional Block Diagram

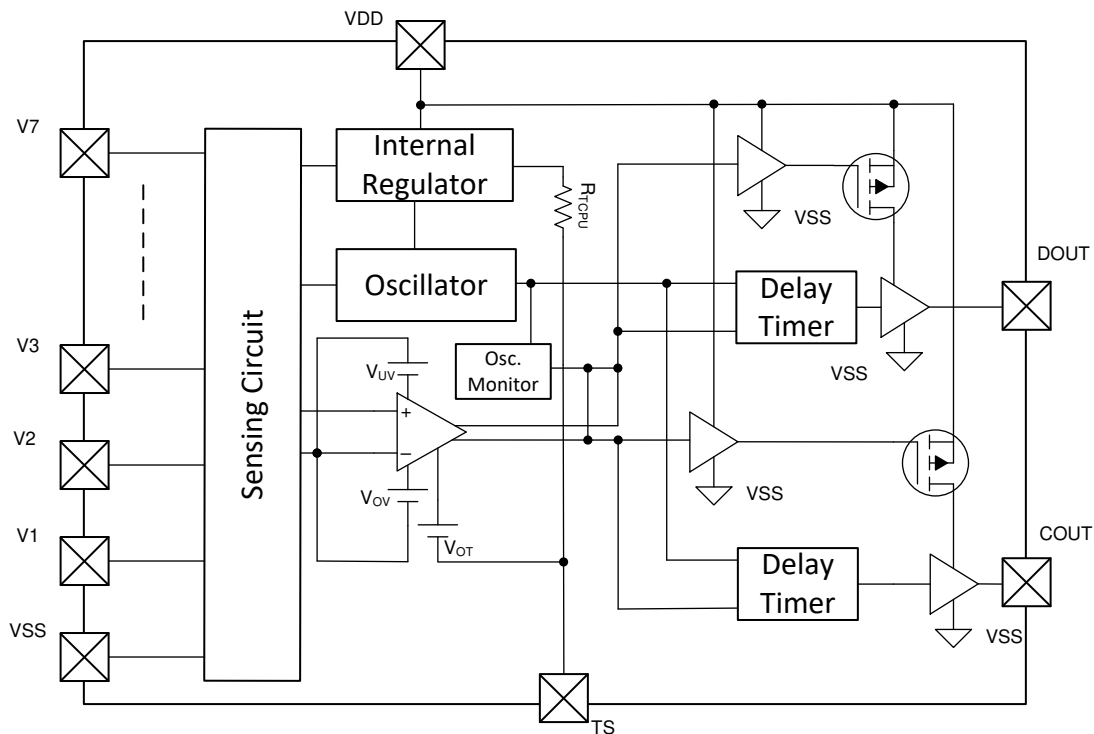

9.3 Feature Description

9.3.1 Voltage Fault Detection

In the BQ77207 device, each cell is monitored independently. Overvoltage is detected by comparing the actual cell voltage to a protection voltage reference, V_{OV} . If any cell voltage exceeds the programmed OV value, a timer circuit is activated. When the timer expires, the COUT pin goes from inactive to active state. The timer is reset if the cell voltage falls below the recovery threshold ($V_{OV} - V_{OV_HYS}$). Undervoltage is detected by comparing the actual cell voltage to a protection voltage reference, V_{UV} . If any cell voltage falls below the programmed UV value, a timer circuit is activated. When the timer expires, the DOUT pin goes from inactive to active state. The timer is reset if the cell voltage rises below the recovery threshold ($V_{UV} + V_{UV_HYS}$).

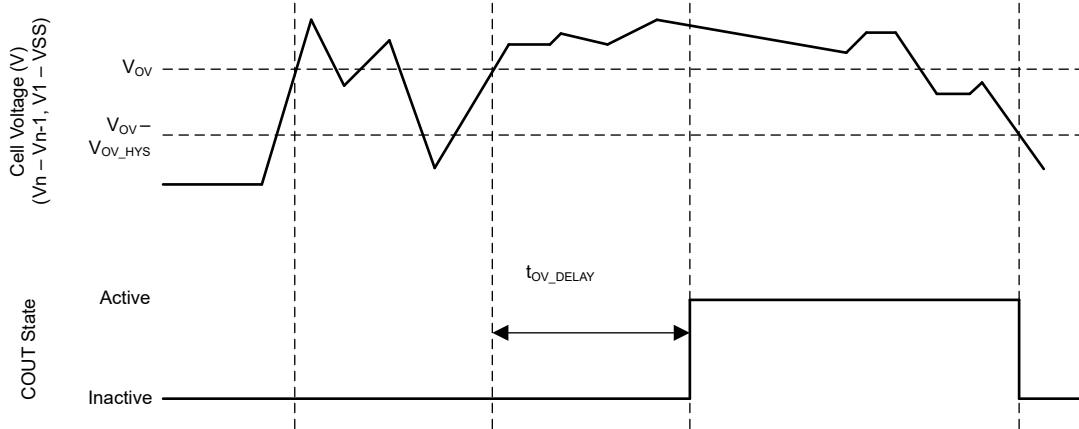

Figure 9-1. Timing for Overvoltage Sensing

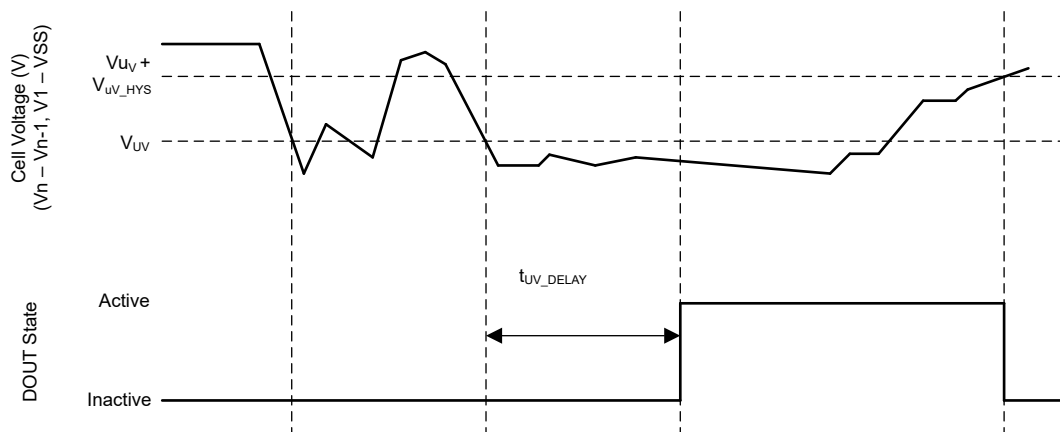

Figure 9-2. Timing for Undervoltage Sensing

9.3.2 Open Wire Fault Detection

In the BQ77207 device, each cell input is monitored independently to determine if the input is connected to a cell or not by applying a 50- μ A pull down current to ground that is activated for 128 μ s every 128 ms. If the device detects that $V_n < V_{n-1} - V_{OW}$ V, then a timer is activated. When the timer expires, the COUT and DOUT pins go from an inactive to active state. The timer is reset if the cell input rises above the recovery threshold ($V_{OW} + V_{OW_HYS}$). To recover both the COUT and DOUT output from active to inactive state, the open wire fault must be cleared (such as the broken connection from the device to the battery needs to be restored), and any other remaining faults (such as existing OVP or UVP faults) need to be cleared as well.

9.3.3 Temperature Fault Detection

In the BQ77207 device, the TS pin is ratiometrically monitored with an internal pull up resistance R_{NTC} . Overtemperature is detected by evaluating the TS input voltage to determine the external resistance falls below a protection resistance, R_{OT_EXT} . If the resistance falls below the programmed OT value, a timer circuit is activated. When the timer expires, the COUT and DOUT pins go from inactive to active state. The timer is reset if the resistance rises above the recovery threshold ($R_{OT} + R_{OT_HYS}$). If external capacitance is added to the TS pin, it needs to be within the spec limit shown in recommended operating conditions.

Note

Texas Instruments does not recommend adding an external capacitor to the TS pin. The capacitance on this pin will affect the TS measurement accuracy if greater than C_{TS} .

9.3.4 Oscillator Health Check

The device can detect if the internal oscillator slows down below the f_{OSC_FAULT} threshold. When this occurs then the COUT and DOUT go from inactive to active state. If the oscillator returns to normal then the fault recovers.

9.3.5 Sense Positive Input for Vx

This is an input to sense each single battery cell voltage. A series resistor and a capacitor across the cell for each input is required for noise filtering and stable voltage monitoring.

9.3.6 Output Drive, COUT and DOUT

These pins serve as the fault signal outputs, and may be ordered in either active HIGH with drive to 6V or active LOW options configured through internal OTP.

The COUT and DOUT will respond per the following table when a fault is detected, if the specific fault is enabled.

Table 9-1. Fault Detection vs COUT and DOUT Action

| FAULT Detected | COUT | DOUT |
|-------------------|----------|----------|
| Overvoltage | Active | Inactive |
| Undervoltage | Inactive | Active |
| Open Wire | Active | Active |
| Over Temperature | Active | Active |
| Oscillator Health | Active | Active |

9.3.7 The LATCH Function

The device can be enabled to latch the fault signal, which effectively disables the recovery functions of all fault detections. The only way to recover from a fault state when the latch is enabled is a POR of the device.

9.3.8 Supply Input, VDD

This pin is the unregulated input power source for the IC. A series resistor is connected to limit the current, and a capacitor is connected to ground for noise filtering.

9.4 Device Functional Modes

9.4.1 NORMAL Mode

When COUT and DOUT are inactive (no fault detected) the device operates in NORMAL mode and device is monitoring for voltage, open wire and temperature faults.

The COUT and DOUT pins are inactive and if configured:

- Active high is low.
- Active low is being externally pulled up and is an open drain.

9.4.2 FAULT Mode

FAULT mode is entered if the COUT or DOUT pins are activated. The OUT pin will either pull high internally, if configured as active high, or will be pulled low internally, if configured as active low. When COUT and DOUT are deactivated the device returns to NORMAL mode.

9.4.3 Customer Test Mode

Customer Test Mode (CTM) helps to reduce test time for checking the delay timer parameter once the circuit is implemented in the battery pack. To enter CTM, VDD should be set to at least V_{CTM} higher than V_7 (see [Figure 9-3](#)). The delay timer is greater than 10 ms, but considerably shorter than the timer delay in normal operation. To exit Customer Test Mode, remove the VDD to a V_7 voltage differential of 10 V so that the decrease in this value automatically causes an exit.

CAUTION

Avoid exceeding any Absolute Maximum Voltages on any pins when placing the part into Customer Test Mode. Also avoid exceeding Absolute Maximum Voltages for the individual cell voltages ($V_{Cn}-V_{Cn-1}$) and ($V1-VSS$). Stressing the pins beyond the rated limits may cause permanent damage to the device.

Figure 9-3 shows the timing for the Customer Test Mode.

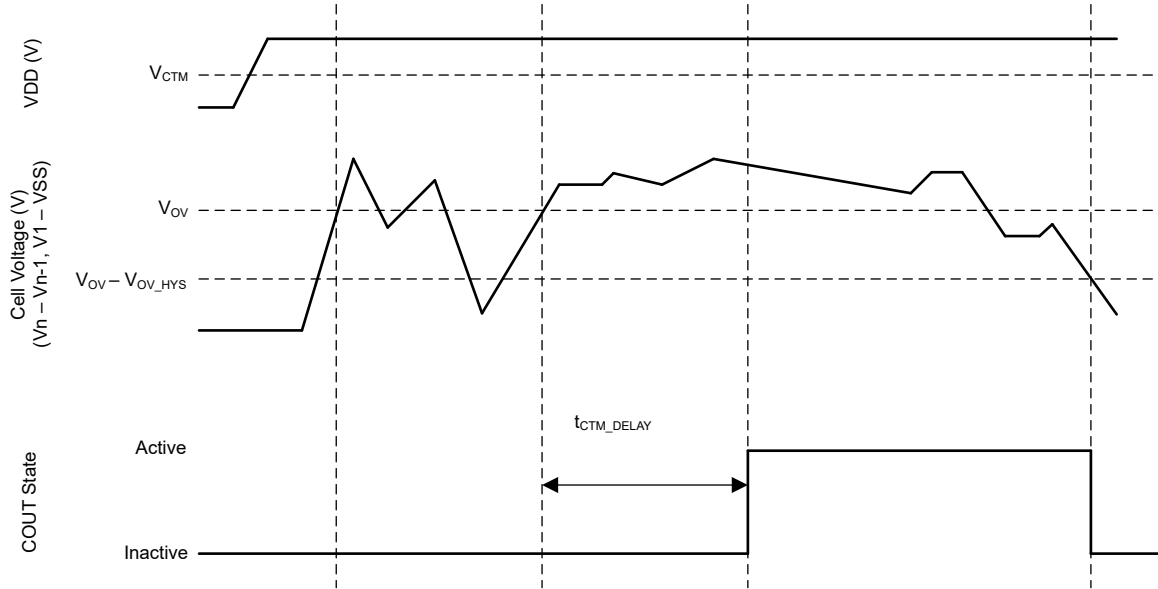

Figure 9-3. Timing for Customer Test Mode

10 Application and Implementation

Note

Information in the following applications sections is not part of the TI component specification, and TI does not warrant its accuracy or completeness. TI's customers are responsible for determining suitability of components for their purposes, as well as validating and testing their design implementation to confirm system functionality.

10.1 Application Information

Changes to the ranges stated in [Table 10-1](#) will impact the accuracy of the cell measurements.

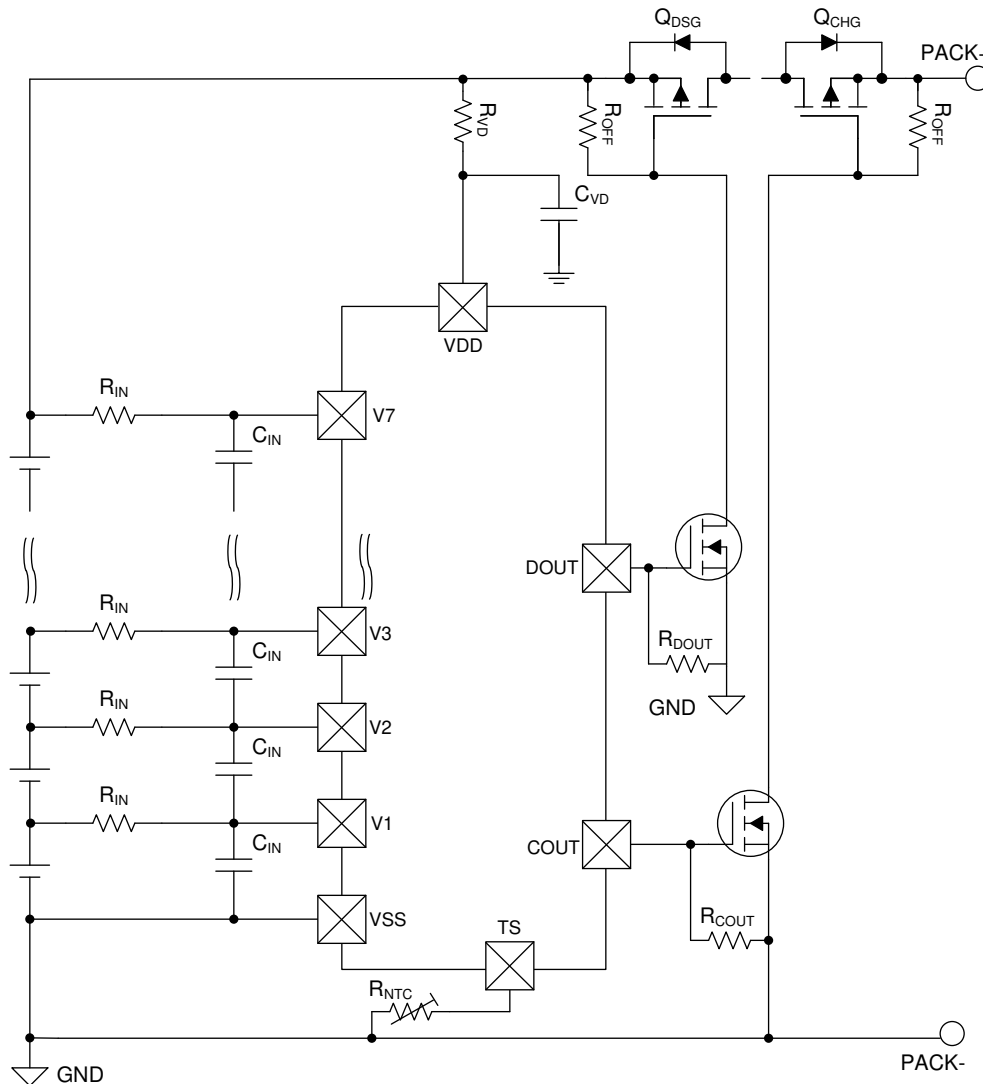

Figure 10-1. Application Configuration

10.1.1 Design Requirements

Changes to the ranges stated in [Table 10-1](#) will impact the accuracy of the cell measurements. [Figure 10-1](#) shows each external component.

Table 10-1. Parameters

| PARAMETER | EXTERNAL COMPONENT | MIN | NOM | MAX | UNIT |
|-----------------------------------|--------------------|-----|------|------|----------|
| Voltage monitor filter resistance | R_{IN} | 900 | 1000 | 1100 | Ω |

Table 10-1. Parameters (continued)

| PARAMETER | EXTERNAL COMPONENT | MIN | NOM | MAX | UNIT |
|------------------------------------|--------------------|------|-----|-----|---------------|
| Voltage monitor filter capacitance | C_{IN} | 0.01 | | 0.1 | μF |
| Supply voltage filter resistance | R_{VD} | 100 | 300 | 1K | Ω |
| Supply voltage filter capacitance | C_{VD} | 0.05 | 0.1 | 1 | μF |

Note

The device is calibrated using an R_{IN} value = 1 k Ω . Using a value other than this recommended value changes the accuracy of the cell voltage measurements and V_{OV} trigger level.

10.1.2 Detailed Design Procedure

Figure 10-2 shows the measurement for current consumption for the product for both VDD and V_x .

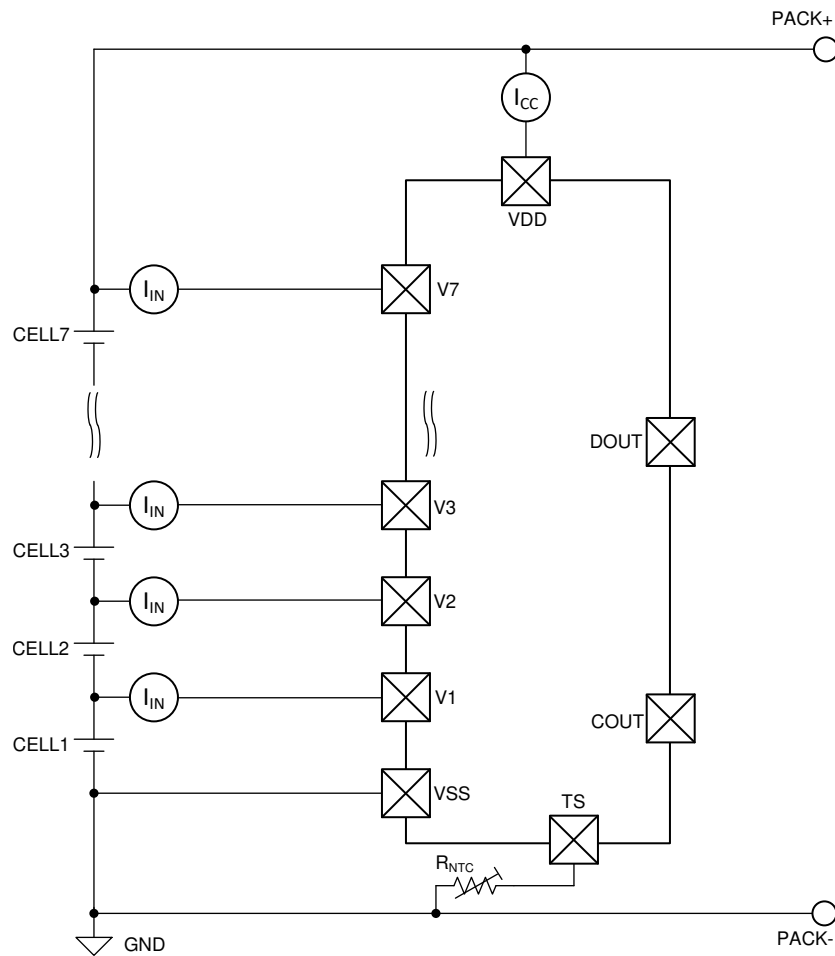

Figure 10-2. Configuration for IC Current Consumption Test

10.1.2.1 Cell Connection Sequence

The BQ77207 device can be connected to the array of cells in any order without damaging the device.

During cell attachment, the device could detect a fault if the cells are not connected within a fault detection delay period. If this occurs, then COUT and/or DOUT could transition from inactive to active. Both COUT and DOUT can be tied to VSS or VDD to prevent any change in output state during cell attach.

10.2 Systems Example

In this application example, the choice of a FUSE or FETs is required on the COUT and DOUT pins—configured as an active high drive to 6-V outputs.

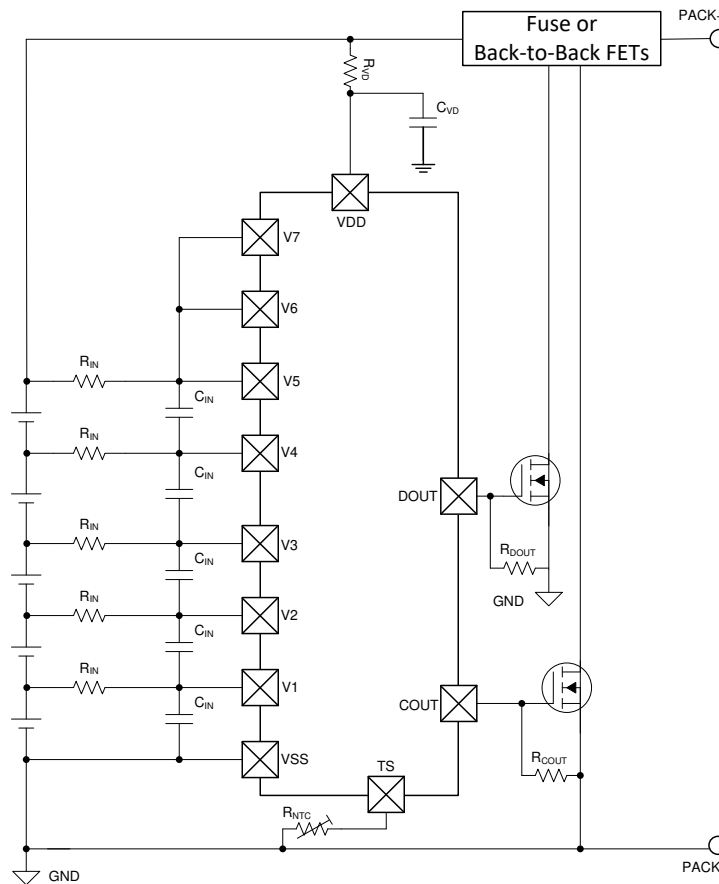

Figure 10-3. 5-Series Cell Configuration with Active High 6-V Option

When pairing with the BQ769x2 or BQ76940 devices, the top cell must be used. For the BQ77207 device to drive the CHG and DSG FETs, the active high 6-V option is preferred. Its COUT and DOUT are controlling two N-CH FETs to jointly control the CHG and DSG FETs with the monitoring device. For such joint architecture, the open-wire feature of the BQ77207 device may be affected if the primary protector or monitor device is actively measuring the cells. Care is needed to ensure the V_{OW} spec of the BQ77207 device is met or to choose a version of the BQ77207 device with open wire disabled. When working with a BQ769x2 device, the LOOPSLOW setting of the BQ769x2 device should be set to 0x11 to ensure the BQ77207 V_{OW} spec is met.

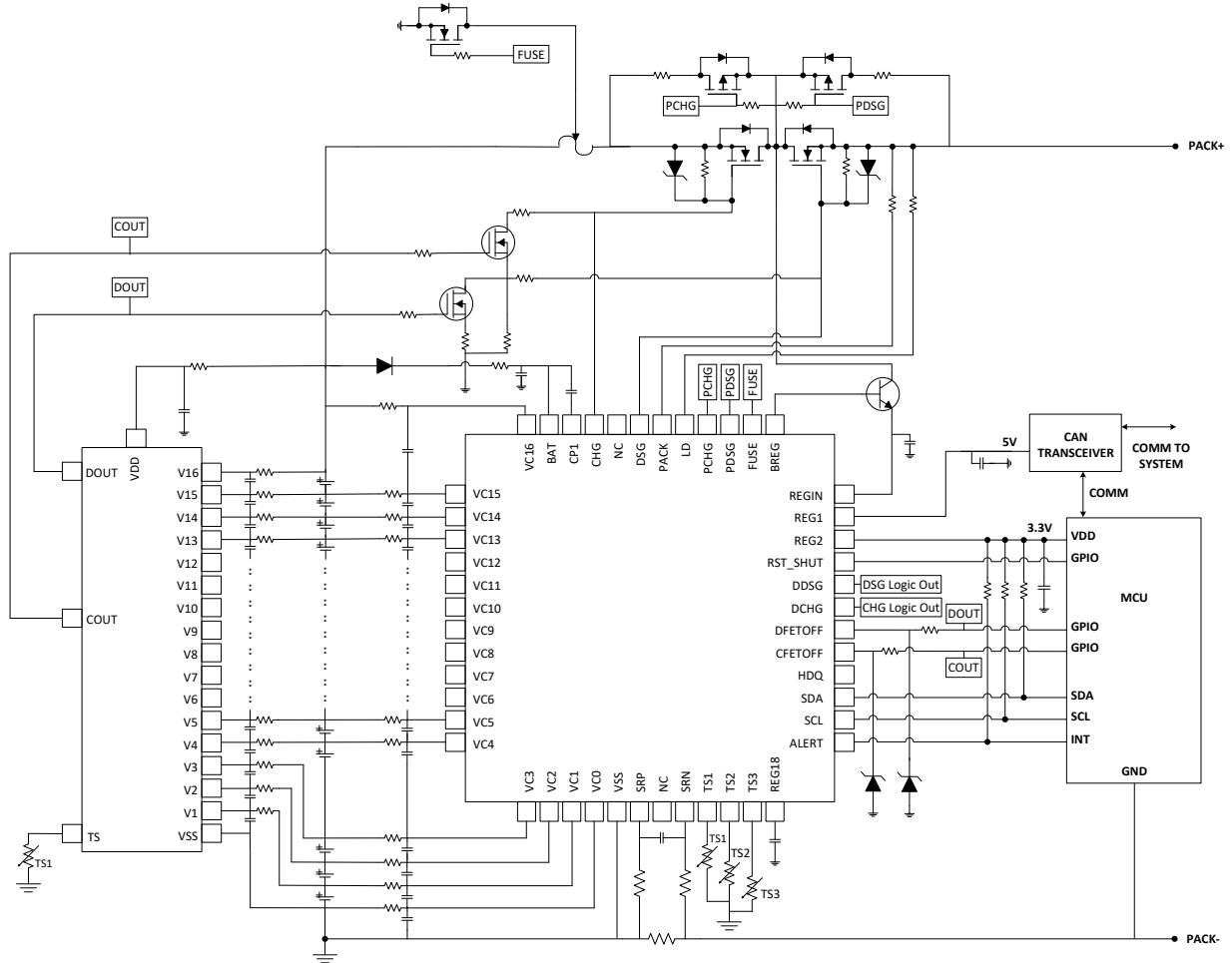

Figure 10-4. BQ77207 with BQ6952

11 Power Supply Recommendations

The maximum power supply of this device is 38.5 V on VDD.

12 Layout

12.1 Layout Guidelines

- Ensure the RC filters for the Vn and VDD pins are placed as close as possible to the target terminal.
- The VSS pin should be routed to the CELL– terminal.

12.2 Layout Example

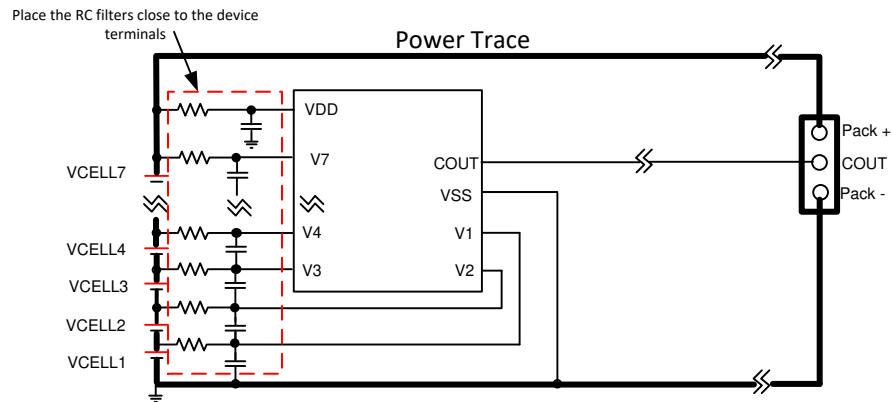

Figure 12-1. Example Layout

13 Device and Documentation Support

13.1 Third-Party Products Disclaimer

TI'S PUBLICATION OF INFORMATION REGARDING THIRD-PARTY PRODUCTS OR SERVICES DOES NOT CONSTITUTE AN ENDORSEMENT REGARDING THE SUITABILITY OF SUCH PRODUCTS OR SERVICES OR A WARRANTY, REPRESENTATION OR ENDORSEMENT OF SUCH PRODUCTS OR SERVICES, EITHER ALONE OR IN COMBINATION WITH ANY TI PRODUCT OR SERVICE.

13.2 Receiving Notification of Documentation Updates

To receive notification of documentation updates, navigate to the device product folder on [ti.com](https://www.ti.com). Click on *Subscribe to updates* to register and receive a weekly digest of any product information that has changed. For change details, review the revision history included in any revised document.

13.3 Support Resources

[TI E2E™ support forums](#) are an engineer's go-to source for fast, verified answers and design help — straight from the experts. Search existing answers or ask your own question to get the quick design help you need.

Linked content is provided "AS IS" by the respective contributors. They do not constitute TI specifications and do not necessarily reflect TI's views; see TI's [Terms of Use](#).

13.4 Trademarks

TI E2E™ is a trademark of Texas Instruments.
All trademarks are the property of their respective owners.

13.5 Electrostatic Discharge Caution



This integrated circuit can be damaged by ESD. Texas Instruments recommends that all integrated circuits be handled with appropriate precautions. Failure to observe proper handling and installation procedures can cause damage.

ESD damage can range from subtle performance degradation to complete device failure. Precision integrated circuits may be more susceptible to damage because very small parametric changes could cause the device not to meet its published specifications.

13.6 Glossary

[TI Glossary](#) This glossary lists and explains terms, acronyms, and definitions.

14 Mechanical, Packaging, and Orderable Information

The following pages include mechanical, packaging, and orderable information. This information is the most current data available for the designated devices. This data is subject to change without notice and revision of this document. For browser-based versions of this data sheet, refer to the left-hand navigation.

PACKAGING INFORMATION

| Orderable Device | Status (1) | Package Type | Package Drawing | Pins | Package Qty | Eco Plan (2) | Lead finish/ Ball material (6) | MSL Peak Temp (3) | Op Temp (°C) | Device Marking (4/5) | Samples |
|------------------|---------------|--------------|-----------------|------|-------------|-----------------|--------------------------------------|----------------------|--------------|-------------------------|-------------------------|
| BQ7720700DSSR | ACTIVE | WSON | DSS | 12 | 3000 | RoHS & Green | NIPDAU | Level-1-260C-UNLIM | -40 to 110 | 720700 | Samples |
| BQ7720701DSSR | ACTIVE | WSON | DSS | 12 | 3000 | RoHS & Green | NIPDAU | Level-1-260C-UNLIM | -40 to 110 | 720701 | Samples |
| BQ7720702DSSR | ACTIVE | WSON | DSS | 12 | 3000 | RoHS & Green | NIPDAU | Level-1-260C-UNLIM | -40 to 110 | 720702 | Samples |

(1) The marketing status values are defined as follows:

ACTIVE: Product device recommended for new designs.

LIFEBUY: TI has announced that the device will be discontinued, and a lifetime-buy period is in effect.

NRND: Not recommended for new designs. Device is in production to support existing customers, but TI does not recommend using this part in a new design.

PREVIEW: Device has been announced but is not in production. Samples may or may not be available.

OBSOLETE: TI has discontinued the production of the device.

(2) **RoHS:** TI defines "RoHS" to mean semiconductor products that are compliant with the current EU RoHS requirements for all 10 RoHS substances, including the requirement that RoHS substance do not exceed 0.1% by weight in homogeneous materials. Where designed to be soldered at high temperatures, "RoHS" products are suitable for use in specified lead-free processes. TI may reference these types of products as "Pb-Free".

RoHS Exempt: TI defines "RoHS Exempt" to mean products that contain lead but are compliant with EU RoHS pursuant to a specific EU RoHS exemption.

Green: TI defines "Green" to mean the content of Chlorine (Cl) and Bromine (Br) based flame retardants meet JS709B low halogen requirements of <=1000ppm threshold. Antimony trioxide based flame retardants must also meet the <=1000ppm threshold requirement.

(3) MSL, Peak Temp. - The Moisture Sensitivity Level rating according to the JEDEC industry standard classifications, and peak solder temperature.

(4) There may be additional marking, which relates to the logo, the lot trace code information, or the environmental category on the device.

(5) Multiple Device Markings will be inside parentheses. Only one Device Marking contained in parentheses and separated by a "~" will appear on a device. If a line is indented then it is a continuation of the previous line and the two combined represent the entire Device Marking for that device.

(6) Lead finish/Ball material - Orderable Devices may have multiple material finish options. Finish options are separated by a vertical ruled line. Lead finish/Ball material values may wrap to two lines if the finish value exceeds the maximum column width.

Important Information and Disclaimer:The information provided on this page represents TI's knowledge and belief as of the date that it is provided. TI bases its knowledge and belief on information provided by third parties, and makes no representation or warranty as to the accuracy of such information. Efforts are underway to better integrate information from third parties. TI has taken and continues to take reasonable steps to provide representative and accurate information but may not have conducted destructive testing or chemical analysis on incoming materials and chemicals. TI and TI suppliers consider certain information to be proprietary, and thus CAS numbers and other limited information may not be available for release.

In no event shall TI's liability arising out of such information exceed the total purchase price of the TI part(s) at issue in this document sold by TI to Customer on an annual basis.

TAPE AND REEL INFORMATION

QUADRANT ASSIGNMENTS FOR PIN 1 ORIENTATION IN TAPE

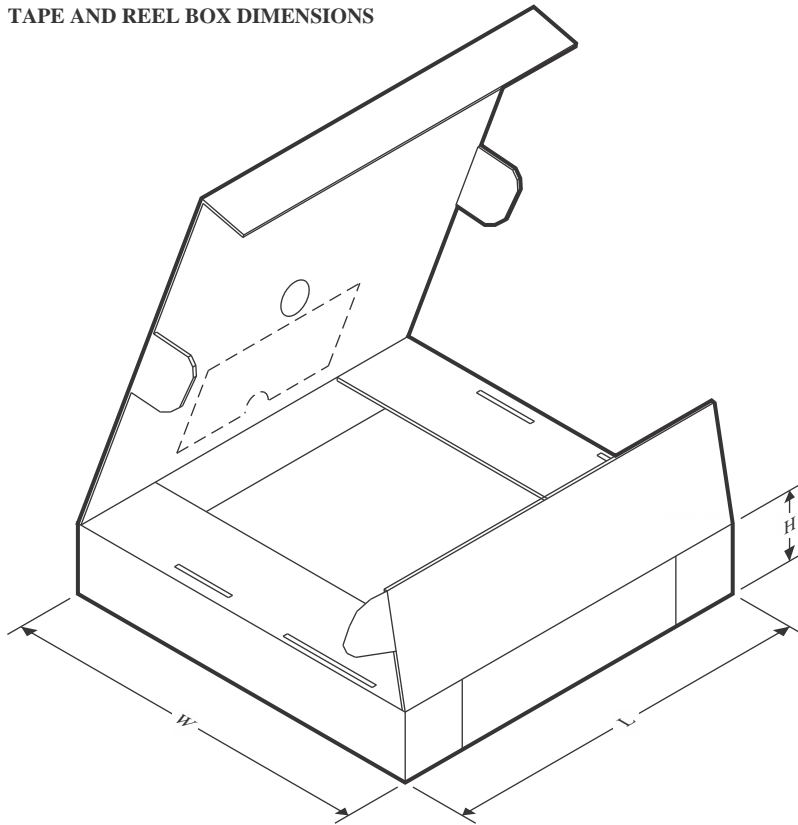

*All dimensions are nominal

| Device | Package Type | Package Drawing | Pins | SPQ | Reel Diameter (mm) | Reel Width W1 (mm) | A0 (mm) | B0 (mm) | K0 (mm) | P1 (mm) | W (mm) | Pin1 Quadrant |
|---------------|--------------|-----------------|------|------|--------------------|--------------------|---------|---------|---------|---------|--------|---------------|
| BQ7720700DSSR | WSON | DSS | 12 | 3000 | 180.0 | 8.4 | 2.25 | 3.25 | 1.05 | 4.0 | 8.0 | Q1 |
| BQ7720701DSSR | WSON | DSS | 12 | 3000 | 180.0 | 8.4 | 2.25 | 3.25 | 1.05 | 4.0 | 8.0 | Q1 |
| BQ7720702DSSR | WSON | DSS | 12 | 3000 | 180.0 | 8.4 | 2.25 | 3.25 | 1.05 | 4.0 | 8.0 | Q1 |

TAPE AND REEL BOX DIMENSIONS

*All dimensions are nominal

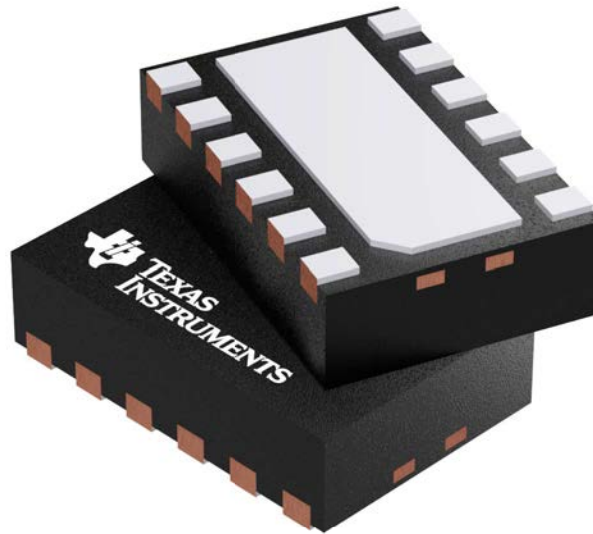
| Device | Package Type | Package Drawing | Pins | SPQ | Length (mm) | Width (mm) | Height (mm) |
|---------------|--------------|-----------------|------|------|-------------|------------|-------------|
| BQ7720700DSSR | WSON | DSS | 12 | 3000 | 210.0 | 185.0 | 35.0 |
| BQ7720701DSSR | WSON | DSS | 12 | 3000 | 210.0 | 185.0 | 35.0 |
| BQ7720702DSSR | WSON | DSS | 12 | 3000 | 210.0 | 185.0 | 35.0 |



Images above are just a representation of the package family, actual package may vary.
Refer to the product data sheet for package details.

DSS0012B



PACKAGE OUTLINE

WSON - 0.8 mm max height

PLASTIC SMALL OUTLINE - NO LEAD

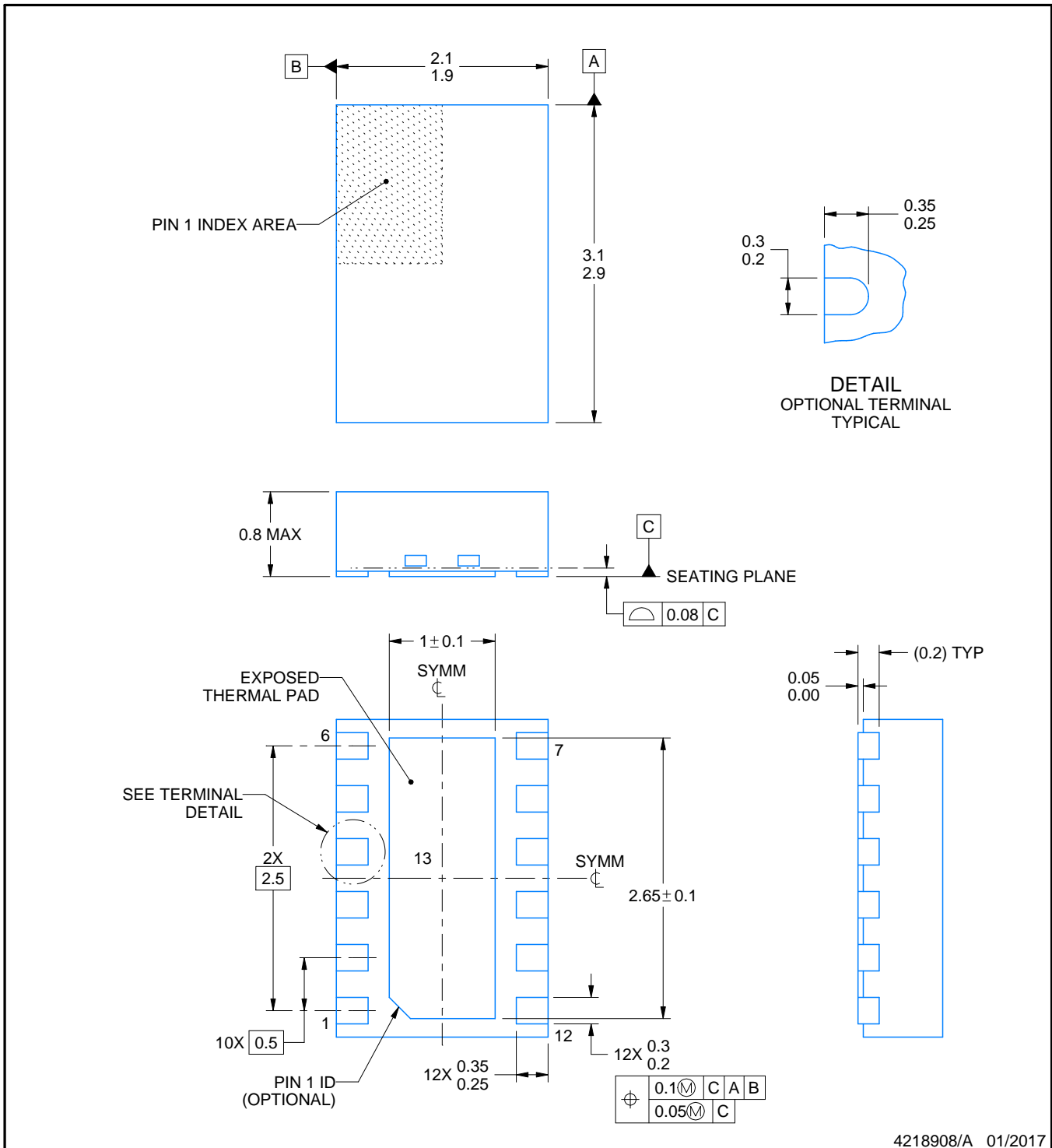

4218908/A 01/2017

NOTES:

1. All linear dimensions are in millimeters. Any dimensions in parenthesis are for reference only. Dimensioning and tolerancing per ASME Y14.5M.
2. This drawing is subject to change without notice.
3. The package thermal pad must be soldered to the printed circuit board for optimal thermal and mechanical performance.

EXAMPLE BOARD LAYOUT

DSS0012B

WSON - 0.8 mm max height

PLASTIC SMALL OUTLINE - NO LEAD

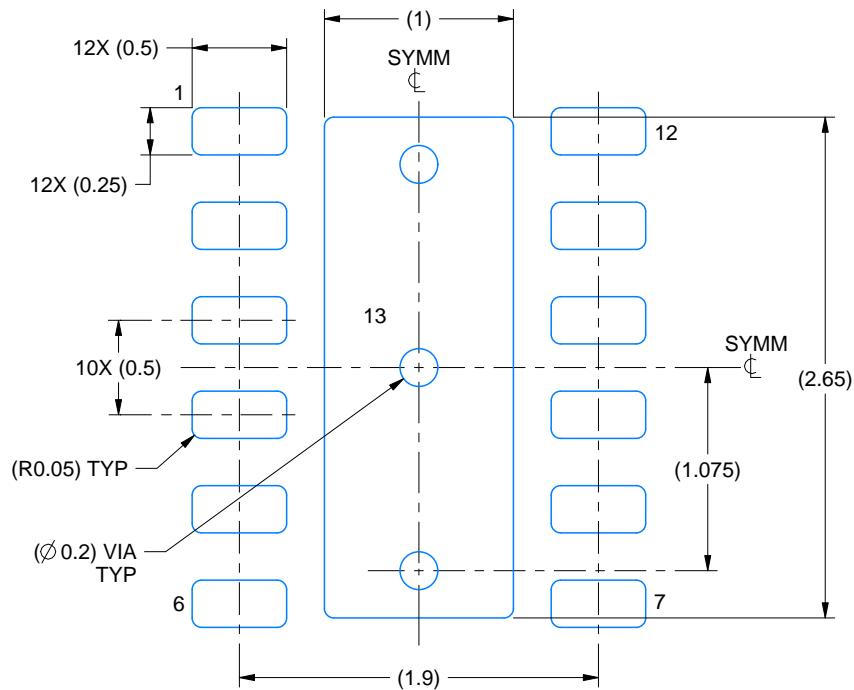

LAND PATTERN EXAMPLE
EXPOSED METAL SHOWN
SCALE:25X

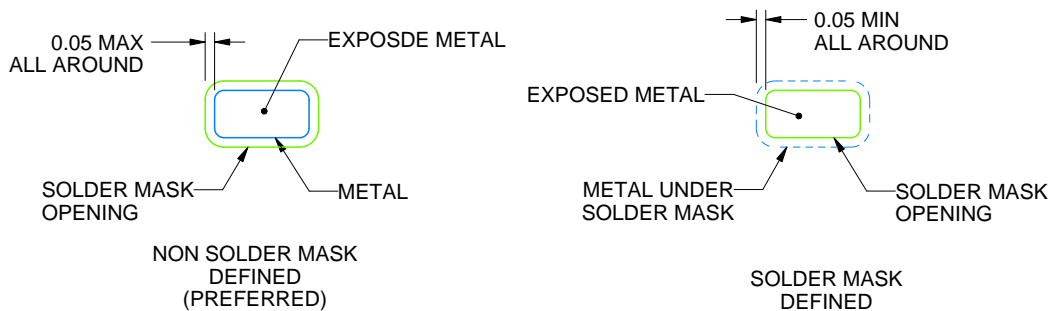

SOLDER MASK DETAILS

4218908/A 01/2017

NOTES: (continued)

4. This package is designed to be soldered to a thermal pad on the board. For more information, see Texas Instruments literature number SLUA271 (www.ti.com/lit/sluea271).
5. Vias are optional depending on application, refer to device data sheet. If any vias are implemented, refer to their locations shown on this view. It is recommended that vias under paste be filled, plugged or tented.

EXAMPLE STENCIL DESIGN

DSS0012B

WSON - 0.8 mm max height

PLASTIC SMALL OUTLINE - NO LEAD

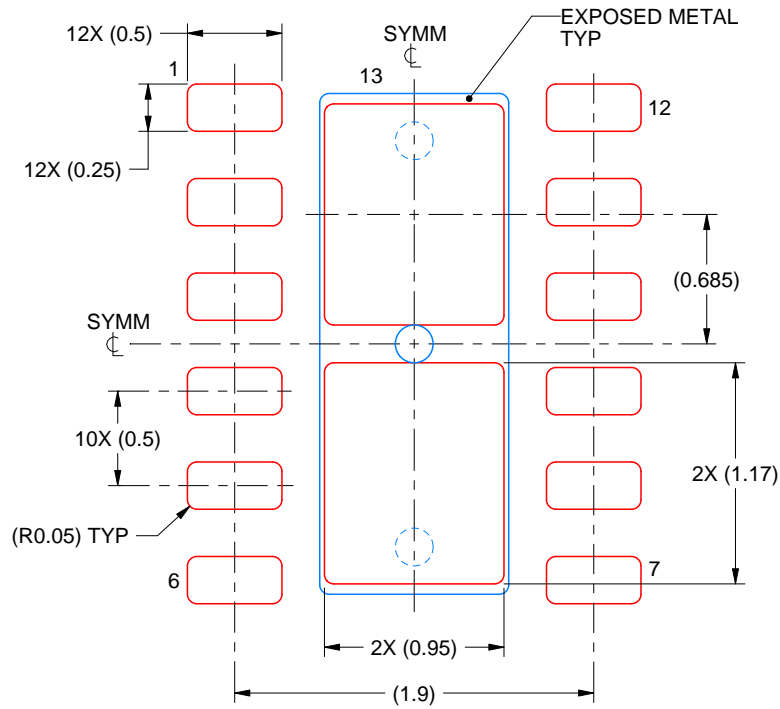

SOLDER PASTE EXAMPLE
BASED ON 0.125 mm THICK STENCIL

EXPOSED PAD 13:
83% PRINTED SOLDER COVERAGE BY AREA UNDER PACKAGE
SCALE:25X

4218908/A 01/2017

NOTES: (continued)

6. Laser cutting apertures with trapezoidal walls and rounded corners may offer better paste release. IPC-7525 may have alternate design recommendations.

IMPORTANT NOTICE AND DISCLAIMER

TI PROVIDES TECHNICAL AND RELIABILITY DATA (INCLUDING DATA SHEETS), DESIGN RESOURCES (INCLUDING REFERENCE DESIGNS), APPLICATION OR OTHER DESIGN ADVICE, WEB TOOLS, SAFETY INFORMATION, AND OTHER RESOURCES "AS IS" AND WITH ALL FAULTS, AND DISCLAIMS ALL WARRANTIES, EXPRESS AND IMPLIED, INCLUDING WITHOUT LIMITATION ANY IMPLIED WARRANTIES OF MERCHANTABILITY, FITNESS FOR A PARTICULAR PURPOSE OR NON-INFRINGEMENT OF THIRD PARTY INTELLECTUAL PROPERTY RIGHTS.

These resources are intended for skilled developers designing with TI products. You are solely responsible for (1) selecting the appropriate TI products for your application, (2) designing, validating and testing your application, and (3) ensuring your application meets applicable standards, and any other safety, security, regulatory or other requirements.

These resources are subject to change without notice. TI grants you permission to use these resources only for development of an application that uses the TI products described in the resource. Other reproduction and display of these resources is prohibited. No license is granted to any other TI intellectual property right or to any third party intellectual property right. TI disclaims responsibility for, and you will fully indemnify TI and its representatives against, any claims, damages, costs, losses, and liabilities arising out of your use of these resources.

TI's products are provided subject to [TI's Terms of Sale](#) or other applicable terms available either on [ti.com](https://www.ti.com) or provided in conjunction with such TI products. TI's provision of these resources does not expand or otherwise alter TI's applicable warranties or warranty disclaimers for TI products.

TI objects to and rejects any additional or different terms you may have proposed.

Mailing Address: Texas Instruments, Post Office Box 655303, Dallas, Texas 75265
Copyright © 2023, Texas Instruments Incorporated

Looking for pricing, stock, or lifecycle information?

Click below to explore more details on WIN SOURCE:

 [View BQ7720704DSSR](#) on WIN SOURCE

 [Texas Instruments](#) Information

Optimize Your Supply Chain with WIN SOURCE Solutions

-  Global Sourcing Solution
-  Obsolete Management
-  Cost Control Management
-  Shortage Management
-  Alternative Solution
-  Excess Inventory Management