

EFR32ZG14 Z-Wave 700 Modem SoC Data Sheet



The Silicon Labs Z-Wave 700 Modem SoC, EFR32ZG14, is an ideal solution for gateways and controllers in smart home applications such as smart home gateways, smart speakers, set top boxes, USB sticks and more.

The single-die solution provides industry-leading low-power Gecko technology. The EFR32ZG14 features excellent radio sensitivity, improving the range of the Z-Wave mesh network.

EFR32ZG14 applications include Z-Wave controllers and gateways for:

- Smart Home
- Security
- Lighting
- Health and Wellness
- Metering
- Building Automation

This modem SoC part is suitable for Z-Wave controllers and gateways only, and cannot be used for end-devices.

KEY FEATURES
• TX power up to 14 dBm
• RX sensitivity @ 100 kbps: -106 dBm
• 32-bit ARM® Cortex®-M4 core at 39 MHz
• Z-Wave Long Range

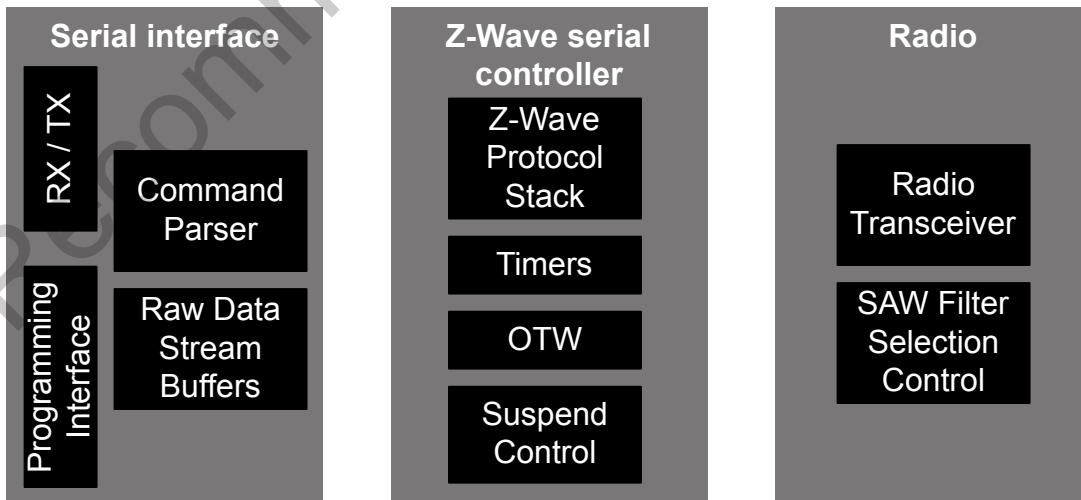

1. Feature List

The EFR32ZG14 highlighted features are listed below.

- **Low Power Wireless System-on-Chip.**
 - High Performance 32-bit 39 MHz ARM Cortex[®]-M4 with DSP instruction and floating-point unit for efficient signal processing
 - Sub-GHz radio operation
 - Transmit power: Up to 14 dBm
- **Low Energy Consumption**
 - 10.2 mA active radio RX current
 - 10.1 mA idle / listening radio RX current
 - 43.8 mA active radio TX current at 14 dBm output power
 - 38.8 mA active radio TX current at 13 dBm output power
 - 12.9 mA active radio TX current at 0 dBm output power
 - USB-compliant in low-power suspend mode
- **High Receiver Performance**
 - -98.6 dBm sensitivity at 100 kbit/s GFSK, 868 MHz
 - -98.8 dBm sensitivity at 100 kbit/s GFSK, 915 MHz
 - -106 dBm sensitivity at 100 kbit/s DSSS O-QPSK, 912 MHz
- **Supported Modulation Formats**
 - 2 (G)FSK with fully configurable shaping
 - DSSS O-QPSK
- **Supported Protocols:**
 - Z-Wave
 - Z-Wave Long Range
- **Selection of MCU peripherals**
 - 9 Dedicated GPIO's for : UART communication, suspend mode operation, PTI interface, Serial Wire Debug, and optional SAW filter selection
 - Built-in supply monitor
 - UART serial interface
 - PTI interface
- **Wide Operating Range**
 - 1.8 to 3.8 V single power supply with integrated DC-DC
 - -40 °C to 85 °C
- **QFN32 5x5 mm Package**

2. Ordering Information

Table 2.1. Ordering Information

Ordering Code	Protocol Stack	Frequency Band @ Max TX Power	Flash (kB)	RAM (kB)	GPIO	Package
EFR32ZG14P231F256GM32-B	Z-Wave	Sub-GHz @ 14 dBm	256	32	9	QFN32

Not Recommended for New Designs

Table of Contents

1. Feature List	2
2. Ordering Information	3
3. System Overview	5
3.1 Introduction	5
3.2 Power Configuration	5
3.2.1 Power Modes	5
3.3 Radio Interface	6
3.4 Embedded Interface	7
3.5 Device Software	7
4. Electrical Specifications	8
4.1 Electrical Characteristics	8
4.1.1 Absolute Maximum Ratings	8
4.1.2 Operating Conditions	9
4.1.3 Thermal Characteristics	10
4.1.4 DC-DC Converter	10
4.1.5 Current Consumption	11
4.1.6 Brown Out Detector (BOD)	12
4.1.7 Sub-GHz RF Transceiver Characteristics	13
4.1.8 High-Frequency Crystal Oscillator (HFXO)	20
4.1.9 I/O Characteristics	21
4.2 Typical Performance Curves	21
4.2.1 Supply Current	22
4.2.2 Z-Wave Radio	24
5. Typical Connection Diagrams	25
5.1 Z-Wave	25
5.2 Z-Wave Long Range	26
6. EFR32ZG14 Device Pinout	27
7. QFN32 Package Specifications	29
7.1 QFN32 Package Dimensions	29
7.2 QFN32 PCB Land Pattern	31
7.3 QFN32 Package Marking	33
8. Revision History	34

3. System Overview

3.1 Introduction

The Z-Wave 700 EFR32ZG14 is a serial modem device which takes advantage of Silicon Labs EFR32 SoC technology to provide a low-power, high-performance Z-Wave gateway. The EFR32ZG14 consists of a simple serial port to communicate with the host controller, and a sub-GHz radio for RF communications to Z-Wave end devices. The Z-Wave protocol stack is fully implemented on chip, and a simple serial API is used for data and control.

3.2 Power Configuration

The EFR32ZG14 is powered from a single external supply voltage. An on-chip DC-DC converter provides energy efficiency for the radio and digital subsystems. On-chip supply monitors safely manage power-up, power-down, and brown-out conditions.

Typical power supply circuitry for the EFR32ZG14 is shown below. The main system supply should be attached to VREGVDD, AVDD and IOVDD, while the DC-DC regulates the digital (DVDD) and radio (RFVDD) supplies.

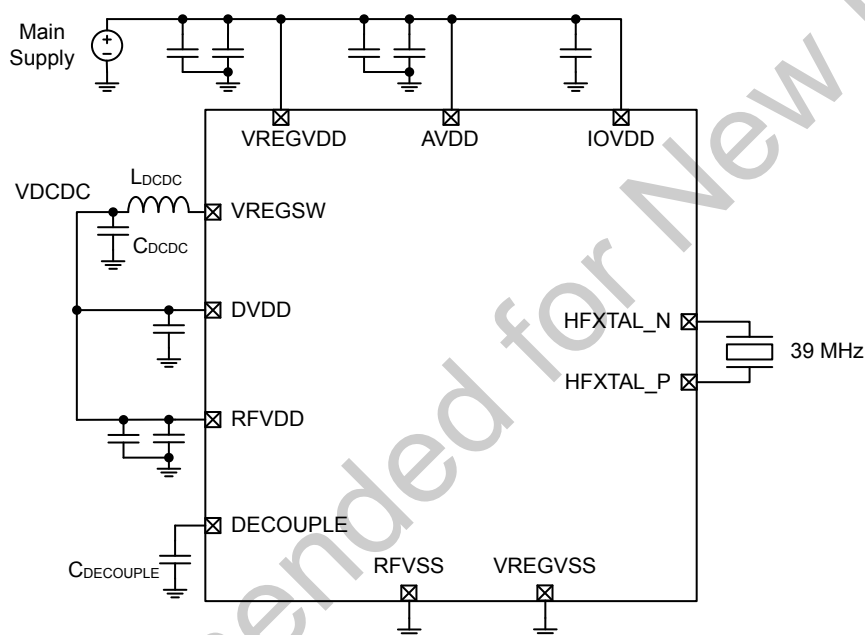

Figure 3.1. Power Supply Connections

3.2.1 Power Modes

The EFR32ZG14 uses different power modes during operation to minimize the energy consumed by the system. When the radio is active, either listening, receiving, or transmitting, the EFR32ZG14 manages these power modes automatically, without requiring instruction from the host controller.

The host can also place the device into a low power standby state using the SUSPENDn pin. When standby is active, the radio and serial interfaces are shut down and any RF connections are terminated. The system will re-establish communication when standby is released.

3.3 Radio Interface

The EFR32ZG14 includes a sub-GHz radio capable of implementing Z-Wave protocol. The differential radio interface connects to an external IPD circuit and antenna, as shown in [Figure 3.2 Radio Interface with IPD on page 6](#).

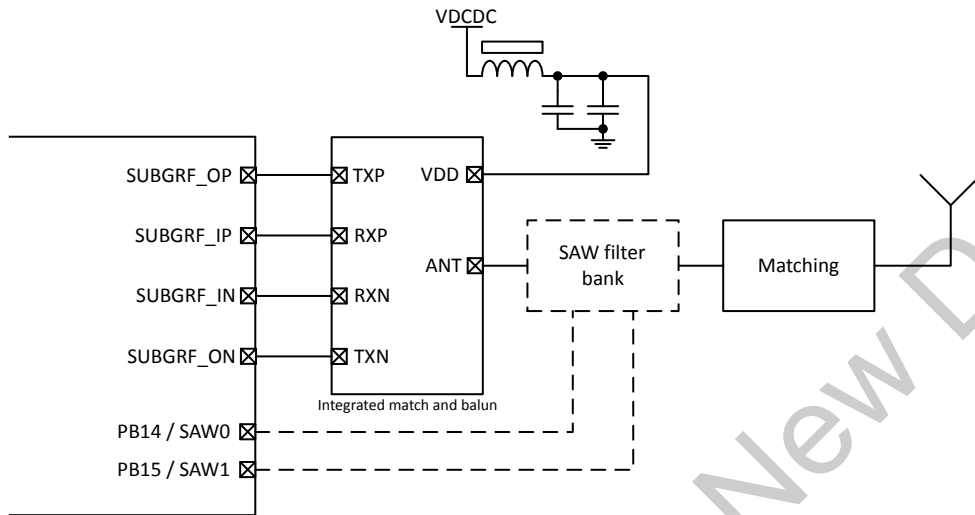

Figure 3.2. Radio Interface with IPD

To implement Z-Wave Long Range, the differential radio interface needs to connect to a circuit with a balun, discrete components and antenna, as shown in [Figure 3.3 Radio Interface with Balun for Z-Wave Long Range on page 6](#)

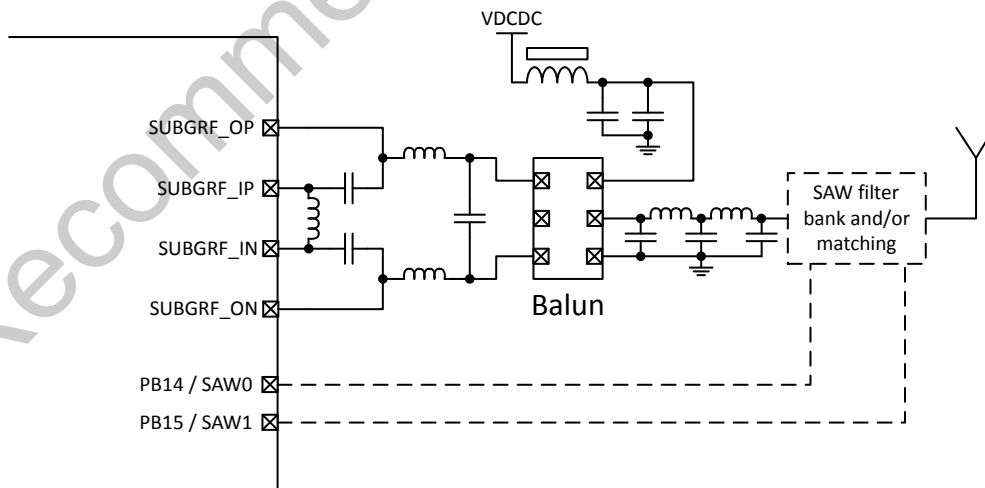

Figure 3.3. Radio Interface with Balun for Z-Wave Long Range

For Z-Wave gateways outside EU frequency and with LTE embedded, it is recommended to analyze the specific need for a SAW filter in depth.

Optionally, a SAW filter bank can be added and controlled via the SAW0 and SAW1 output pins for operation in different regions. [Table 3.1 SAW Filter Selection on page 7](#) details the logic output levels for different SAW filters.

Table 3.1. SAW Filter Selection

SAW1 / PB15	SAW0 / PB14	Saw Filter
0	0	H SAW Filter Selected
0	1	E SAW Filter Selected
1	0	U SAW Filter Selected

Note: The state 1, 1 for SAW1, SAW0 is undefined.

Consult with Z-Wave Global Regions frequency list to identify country specific frequency and corresponding SAW filter.

In systems where switchable filtering is not required, SAW0 and SAW1 should be left unconnected, and the appropriate RF filtering should be used.

3.4 Embedded Interface

A host controller communicates with the EFR32ZG14 using a serial API over a standard 115,200 baud UART serial interface, shown in [Figure 3.4 Host Interface Connections on page 7](#). The RESETn signal is an active-low reset which brings the EFR32ZG14 back to its initial power-on state. An optional active-low SUSPENDn signal may also be used to place the EFR32ZG14 modem in a low power mode when radio functions are not required. PTI_SYNC and PTI_DATA are for packet trace interface. PTI_SYNC and SUSPENDn share the same pin (PB13), and both PTI function and SUSPEND function are disabled by default. Either one of them can be enabled using serial API at runtime. The host may also supply a programming interface to update EFR32ZG14 firmware.

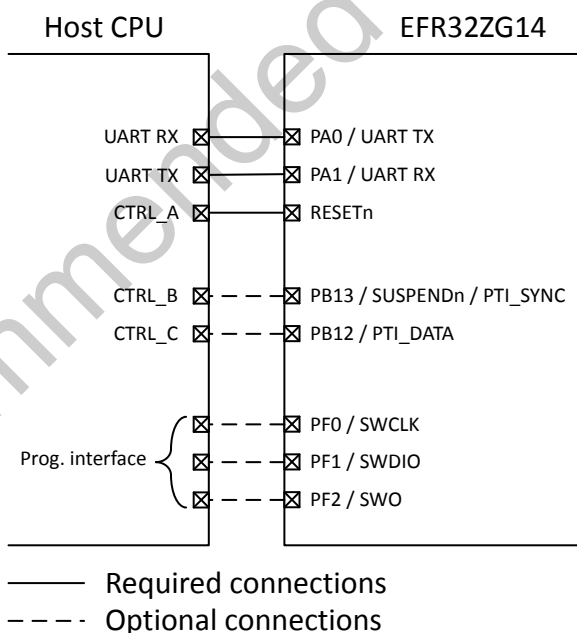

Figure 3.4. Host Interface Connections

More details of the serial API are found in INS12350 “Serial API Host Appl. Prg. Guide”.

3.5 Device Software

The EFR32ZG14 is based on a re-programmable system-on-chip MCU + radio solution. Software is provided as a pre-compiled binary image that may be installed through a standard ARM SWD interface. The binary is available for download at <https://www.silabs.com>.

4. Electrical Specifications

4.1 Electrical Characteristics

All electrical parameters in all tables are specified under the following conditions, unless stated otherwise:

- Typical values are based on $T_{AMB}=25\text{ }^{\circ}\text{C}$ and $V_{DD}=3.3\text{ V}$, by production test and/or technology characterization.
- Radio performance numbers are measured in conducted mode, based on Silicon Laboratories reference designs using output power-specific external RF impedance-matching networks for interfacing to a $50\ \Omega$ source or load.
- Minimum and maximum values represent the worst conditions across supply voltage, process variation, and operating temperature, unless stated otherwise.

Refer to for more details about operational supply and temperature limits.

4.1.1 Absolute Maximum Ratings

Stresses above those listed below may cause permanent damage to the device. This is a stress rating only and functional operation of the devices at those or any other conditions above those indicated in the operation listings of this specification is not implied. Exposure to maximum rating conditions for extended periods may affect device reliability. For more information on the available quality and reliability data, see the Quality and Reliability Monitor Report at <http://www.silabs.com/support/quality/pages/default.aspx>.

Table 4.1. Absolute Maximum Ratings

Parameter	Symbol	Test Condition	Min	Typ	Max	Unit
Storage temperature range	T_{STG}		-50	—	150	$^{\circ}\text{C}$
Voltage on any supply pin	V_{DDMAX}		-0.3	—	3.8	V
Voltage ramp rate on any supply pin	$V_{DDRAMPMAX}$		—	—	1	V / μs
DC voltage on I/O pins	V_{DIGPIN}		-0.3	—	$IOVDD+0.3$	V
Voltage on HFXTAL_N and HFXTAL_P pins	V_{HFXTAL}		-0.3	—	1.4	V
Absolute voltage on Sub-GHz RF pins	$V_{MAXSUBG}$	Pins SUBGRF_OP and SUBGRF_ON	-0.3	—	3.8	V
		Pins SUBGRF_IP and SUBGRF_IN,	-0.3	—	0.3	V
Total current into VDD power lines	I_{VDDMAX}	Source	—	—	200	mA
Total current into VSS ground lines	I_{VSSMAX}	Sink	—	—	200	mA
Current per I/O pin	I_{IOMAX}	Sink	—	—	50	mA
		Source	—	—	50	mA
Current for all I/O pins	$I_{IOALLMAX}$	Sink	—	—	200	mA
		Source	—	—	200	mA
Junction temperature	T_J	-G grade devices	-40	—	105	$^{\circ}\text{C}$

4.1.2 Operating Conditions

When assigning supply sources, the following requirements must be observed:

- VREGVDD must be greater than or equal to AVDD, DVDD, RFVDD and all IOVDD supplies.
- VREGVDD = AVDD
- DVDD ≤ AVDD
- IOVDD ≤ AVDD
- RFVDD ≤ AVDD

4.1.2.1 General Operating Conditions

Table 4.2. General Operating Conditions

Parameter	Symbol	Test Condition	Min	Typ	Max	Unit
Operating ambient temperature range ¹	T _A	-G temperature grade	-40	25	85	°C
AVDD supply voltage ²	V _{AVDD}		1.8	3.3	3.8	V
VREGVDD operating supply voltage ^{2 3}	V _{VREGVDD}	DCDC in regulation	2.4	3.3	3.8	V
		DCDC in bypass, 50mA load	1.8	3.3	3.8	V
RFVDD operating supply voltage	V _{RFVDD}		1.62	—	V _{VREGVDD}	V
DVDD operating supply voltage	V _{DVDD}		1.62	—	V _{VREGVDD}	V
IOVDD operating supply voltage	V _{IOVDD}	All IOVDD pins	1.62	—	V _{VREGVDD}	V
DECOUPLE output capacitor ^{4 5}	C _{DECOUPLE}		0.75	1.0	2.75	μF
Difference between AVDD and VREGVDD, ABS(AVDD-VREGVDD) ²	dV _{DD}		—	—	0.1	V

Note:

1. The maximum limit on T_A may be lower due to device self-heating, which depends on the power dissipation of the specific application. T_A (max) = T_J (max) - (THETA_{JA} × PowerDissipation). Refer to the Absolute Maximum Ratings table and the Thermal Characteristics table for T_J and THETA_{JA}.
2. VREGVDD must be tied to AVDD. Both VREGVDD and AVDD minimum voltages must be satisfied for the part to operate.
3. The minimum voltage required in bypass mode is calculated using R_{BYP} from the DCDC specification table. Requirements for other loads can be calculated as V_{DVDD_min} + I_{LOAD} * R_{BYP_max}.
4. The system designer should consult the characteristic specs of the capacitor used on DECOUPLE to ensure its capacitance value stays within the specified bounds across temperature and DC bias.
5. VSCALE0 to VSCALE2 voltage change transitions occur at a rate of 10 mV / usec for approximately 20 usec. During this transition, peak currents will be dependent on the value of the DECOUPLE output capacitor, from 35 mA (with a 1 μF capacitor) to 70 mA (with a 2.7 μF capacitor).

4.1.3 Thermal Characteristics

Table 4.3. Thermal Characteristics

Parameter	Symbol	Test Condition	Min	Typ	Max	Unit
Thermal resistance, QFN32 Package	THETA _{JA_QFN32}	2-Layer PCB, Air velocity = 0 m/s	—	82.1	—	°C/W
		2-Layer PCB, Air velocity = 1 m/s	—	64.7	—	°C/W
		2-Layer PCB, Air velocity = 2 m/s	—	56.3	—	°C/W
		4-Layer PCB, Air velocity = 0 m/s	—	36.8	—	°C/W
		4-Layer PCB, Air velocity = 1 m/s	—	32	—	°C/W
		4-Layer PCB, Air velocity = 2 m/s	—	30.6	—	°C/W

4.1.4 DC-DC Converter

Table 4.4. DC-DC Converter

Parameter	Symbol	Test Condition	Min	Typ	Max	Unit
DCDC nominal output capacitor ¹	C _{DCDC}	25% tolerance	4.7	4.7	4.7	μF
DCDC nominal output inductor ¹	L _{DCDC}	20% tolerance	4.7	4.7	4.7	μH

Note:

1. Refer to the Z-Wave Hardware Implementation Guidelines for component selection to achieve optimal performance.

4.1.5 Current Consumption

Unless otherwise indicated, typical conditions are: VREGVDD = AVDD = IOVDD = 3.3 V, DVDD = RFVDD = 1.8 V. T = 25 °C. Minimum and maximum values in this table represent the worst conditions across process variation at T = 25 °C.

Table 4.5. Current Consumption

Parameter	Symbol	Test Condition	Min	Typ	Max	Unit
Current During Active Radio Reception, O-QPSK	I _{ACTIVE_RX_OQPSK}	100 kbit/s, O-QPSK, F=912 MHz	—	10.2	—	mA
Current During Active Radio Reception	I _{ACTIVE_RX}		—	10.5	—	mA
Current With Radio Listening, No Active Reception, O-QPSK	I _{LISTEN_RX_OQPSK}	100 kbit/s, O-QPSK, F=912 MHz	—	10.1	—	mA
Current With Radio Listening, No Active Reception	I _{LISTEN_RX}		—	10.5	—	mA
Current During Active Radio Transmission	I _{ACTIVE_TX}	Radio transmitter output power at 14 dBm	—	43.8	—	mA
		Radio transmitter output power at 13 dBm	—	38.8	—	mA
		Radio transmitter output power at 4 dBm	—	17.2	—	mA
		Radio transmitter output power at 0 dBm	—	12.9	—	mA
CPU-Only Current	I _{CPU_ONLY}	CPU active without radio active	—	3.1	—	mA

4.1.6 Brown Out Detector (BOD)

Table 4.6. Brown Out Detector (BOD)

Parameter	Symbol	Test Condition	Min	Typ	Max	Unit
DVDD BOD threshold	V _{DVddbod}	DVDD rising	—	—	1.62	V
		DVDD falling (EM0/EM1)	1.35	—	—	V
		DVDD falling (EM2/EM3)	1.3	—	—	V
DVDD BOD hysteresis	V _{DVddbod_hyst}		—	18	—	mV
DVDD BOD response time	t _{DVddbod_delay}	Supply drops at 0.1V/μs rate	—	2.4	—	μs
AVDD BOD threshold	V _{AVddbod}	AVDD rising	—	—	1.8	V
		AVDD falling (EM0/EM1)	1.62	—	—	V
		AVDD falling (EM2/EM3)	1.53	—	—	V
AVDD BOD hysteresis	V _{AVddbod_hyst}		—	20	—	mV
AVDD BOD response time	t _{AVddbod_delay}	Supply drops at 0.1V/μs rate	—	2.4	—	μs
EM4 BOD threshold	V _{EM4bod}	AVDD rising	—	—	1.7	V
		AVDD falling	1.45	—	—	V
EM4 BOD hysteresis	V _{EM4bod_hyst}		—	25	—	mV
EM4 BOD response time	t _{EM4bod_delay}	Supply drops at 0.1V/μs rate	—	300	—	μs

4.1.7 Sub-GHz RF Transceiver Characteristics

4.1.7.1 Sub-GHz RF Transmitter characteristics for 915 MHz Band

Unless otherwise indicated, typical conditions are: T = 25 °C, VREGVDD = AVDD = IOVDD = 3.3 V, DVDD = RFVDD = External RF Supply. RFVDD and RF supply paths are filtered using ferrites. Crystal frequency = 39 MHz. RF frequency band 915 MHz. Measured using the Radio Interface with IPD.

Table 4.7. Sub-GHz RF Transmitter characteristics for 915 MHz Band

Parameter	Symbol	Test Condition	Min	Typ	Max	Unit
RF tuning frequency range	F _{RANGE}		902	—	930	MHz
Maximum TX Power ¹	POUT _{MAX}	4 dBm output power setting	—	4	—	dBm
Minimum active TX Power	POUT _{MIN}		—	-30	—	dBm
Output power step size	POUT _{STEP}	output power > 0 dBm	—	0.5	—	dB
Output power variation vs supply at POUT _{MAX}	POUT _{VAR_V}	1.8 V < V _{VREGVDD} < 3.3 V, T = 25 °C	—	1.9	—	dB
Output power variation vs temperature, peak to peak	POUT _{VAR_T}	-40 to +85 °C	—	1.3	—	dB
Output power variation vs RF frequency	POUT _{VAR_F}	T = 25 °C, Over specified RF tuning frequency range	—	0.5	—	dB
Spurious emissions of harmonics at 3 dBm output power, Conducted measurement, 3dBm match, Test Frequency = 908.4 MHz	SPUR _{HARM_FCC_4}	In restricted bands, per FCC Part 15.205 / 15.209	—	-60.0	-42	dBm
		In non-restricted bands, per FCC Part 15.249	—	-58.0	-20	dBc
Spurious emissions out-of-band at 3 dBm output power, Conducted measurement, 3dBm match, Test Frequency = 908.4 MHz	SPUR _{OOB_FCC_4}	In non-restricted bands, per FCC Part 15.249	—	-74.0	-20	dBc
		In restricted bands (30-88 MHz), per FCC Part 15.205 / 15.209	—	-59.2	-46	dBm
		In restricted bands (88-216 MHz), per FCC Part 15.205 / 15.209	—	-72.6	-56	dBm
		In restricted bands (216-960 MHz), per FCC Part 15.205 / 15.209	—	-72.1	-52	dBm
		In restricted bands (>960 MHz), per FCC Part 15.205 / 15.209	—	-66.1	-42	dBm
Power spectral density limit	PSD ₄	PSD per FCC Part 15.249, 9.6Kbps	—	-0.7	—	dBm/3kHz
		PSD per FCC Part 15.249, 40Kbps	—	2.2	—	dBm/3kHz
		PSD per FCC Part 15.249, 100Kbps	—	-4.2	—	dBm/3kHz

Note:

1. If a SAW filter is used, the output power is 2 - 3 dBm lower due to insertion loss. Always adjust the output power to match the limits set by the RF regulatory authorities for the region in which the device is used.

4.1.7.2 Sub-GHz RF Transmitter characteristics for 915 MHz Band, +14 dBm

This table is for the O-QPSK PHY only at +14 dBm. Unless otherwise indicated, typical conditions are: T = 25 °C, VREGVDD = AVDD = IOVDD = 3.3 V, DVDD = RFVDD = External RF Supply. RFVDD and RF supply paths are filtered using ferrites. Crystal frequency = 39 MHz. RF center frequency 912 MHz. Measured using the Radio Interface with Balun for Z-Wave Long Range.

Table 4.8. Sub-GHz RF Transmitter characteristics for 915 MHz Band, +14 dBm

Parameter	Symbol	Test Condition	Min	Typ	Max	Unit
RF tuning frequency range	F _{RANGE}		902	—	930	MHz
Maximum TX Power	POUT _{MAX}	14 dBm output power setting ^{1 2}	—	14.2	—	dBm
Minimum active TX Power	POUT _{MIN}		—	-30	—	dBm
Output power step size	POUT _{STEP}	output power > 0 dBm	—	0.5	—	dB
Output power variation vs supply at POUT _{MAX}	POUT _{VAR_V}	1.8 V < V _{VREGVDD} < 3.3 V, T = 25 °C	—	1.9	—	dB
Output power variation vs temperature, peak to peak	POUT _{VAR_T}	-40 to +85 °C	—	0.7	1.4	dB
Spurious emissions out-of-band at +14 dBm output power, Conducted measurement, +14 dBm match, Test Frequency = 912 MHz	SPUR _{OOB_FCC_14}	In restricted bands (>960 MHz), per FCC 47 CFR §15.205 & §15.209 ^{3 4}	—	-45	-42	dBm
		In non-restricted bands, per FCC 47 CFR §15.247 ⁵	—	-26	-20	dBc
		In restricted bands (30-88 MHz), per FCC 47 CFR §15.205 & §15.209 ^{3 4}	—	-62	-46	dBm
		In restricted bands (88-216 MHz), per FCC 47 CFR §15.205 & §15.209 ^{3 4}	—	-61	-56	dBm
		In restricted bands (216-960 MHz), per FCC 47 CFR §15.205 & §15.209 ^{3 4}	—	-58	-52	dBm
Spurious emissions of harmonics at +14 dBm output power, Conducted measurement, +14 dBm match, Test Frequency = 912 MHz	SPUR _{HARM_FCC_14}	In non-restricted bands, per FCC 47 CFR §15.247 ⁵	—	-26	-20	dBc
		In restricted bands, per FCC 47 CFR §15.205 & §15.209 ^{3 4}	—	-47	-42	dBm
Output power variation vs RF frequency	POUT _{VAR_F}	T = 25 °C, Over Specified RF Tuning Frequency Range	—	0.3	0.6	dB
Error Vector Magnitude, per 802.15.4-2006	EVM	Signal is 100 kbps DSSS-OQPSK reference packet. Modulated according to 802.15.4-2006 OQPSK-BPSK in the 915 MHz band, with pseudo-random packet data content. POUT = +14 dBm.	—	4.9	—	%
Power spectral density limit	PSD ₁₄	PSD per FCC Part 15.247, 100 kbps O-QPSK	—	-0.5	—	dBm/3kHz

Parameter	Symbol	Test Condition	Min	Typ	Max	Unit
Note:						
<ol style="list-style-type: none"> 1. Supported transmit power levels are determined by the ordering part number (OPN). Transmit power ratings for all devices covered in this datasheet can be found in the Max TX Power column of the Ordering Information Table. 2. The 14 dBm match is optimized for best efficiency at 14 dBm. The maximum output power can go up to the maximum rating. Emissions are tested with the output power set to 14 dBm. 3. FCC Title 47 CFR Part 15 Section 15.205 Restricted bands of operation. 4. FCC Title 47 CFR Part 15 Section 15.209 Radiated emission limits; general requirements 5. FCC Title 47 CFR Part 15 Section 15.247 Operation within the bands 902-928 MHz, 2400-2483.5 MHz, and 5725-5850 MHz. 						

Not Recommended for New Designs

4.1.7.3 Sub-GHz RF Receiver Characteristics for 915 MHz Band

Unless otherwise indicated, typical conditions are: T = 25 °C, VREGVDD = AVDD = IOVDD = 3.3 V, DVDD = RFVDD = External RF Supply. RFVDD and RF supply paths are filtered using ferrites. Crystal frequency = 39 MHz. RF frequency band 915 MHz. Measured using the Radio Interface with IPD.

Table 4.9. Sub-GHz RF Receiver Characteristics for 915 MHz Band

Parameter	Symbol	Test Condition	Min	Typ	Max	Unit
Tuning frequency range	F _{RANGE}		902	—	930	MHz
Max usable input level, 1% FER	SAT _{100K}	Desired is reference 100 kbps GFSK signal ¹	—	10	—	dBm
Sensitivity ^{2 3}	SENS	Desired is reference 100 kbps GFSK signal ¹ , 1% FER, frequency = 916 MHz, T ≤ 85 °C	—	-98.8	—	dBm
		Desired is reference 40 kbps 2FSK signal ⁴ , 1% FER, frequency = 908.4 MHz, T ≤ 85 °C	—	-102.8	—	dBm
		Desired is reference 100 kbps O-QPSK signal ⁵ , 1% FER, frequency = 912 MHz, T ≤ 85 °C ⁶	—	-106	—	dBm
		Desired is reference 9.6 kbps 2FSK signal ⁷ , 1% FER, frequency = 908.42 MHz, T ≤ 85 °C	—	-103.9	—	dBm
Image rejection, Interferer is CW at image frequency	C/I _{IMAGE}	Desired is 100 kbps GFSK signal ¹ at 3dB above sensitivity level, 1% FER, frequency = 916 MHz	—	33	—	dB
		Desired is reference 40 kbps 2FSK signal ⁴ at 3dB above sensitivity level, 1% FER, frequency = 908.4 MHz	—	34.3	—	dB
		Desired is reference 100 kbps O-QPSK signal ⁵ , 1% FER, frequency = 912 MHz ⁶	—	45.3	—	dB
		Desired is reference 9.6 kbps 2FSK signal ⁷ at 3dB above sensitivity level, 1% FER, frequency = 908.42 MHz	—	34.7	—	dB
Blocking selectivity, 1% FER. Desired is 100 kbps GFSK signal ¹ at 3dB above sensitivity level, frequency = 916 MHz	C/I _{BLOCKER_100}	Interferer CW at Desired ± 1 MHz	—	47.1	—	dB
		Interferer CW at Desired ± 2 MHz	—	52.7	—	dB
		Interferer CW at Desired ± 5 MHz	—	61.3	—	dB
		Interferer CW at Desired ± 10 MHz ⁸	—	65.7	—	dB
		Interferer CW at Desired ± 100 MHz ⁸	—	78.0	—	dB

Parameter	Symbol	Test Condition	Min	Typ	Max	Unit
Blocking selectivity, 1% FER. Desired is 40 kbps 2FSK signal ⁴ at 3dB above sensitivity level, frequency = 908.4 MHz	C/I _{BLOCKER_40}	Interferer CW at Desired ± 1 MHz	—	53.1	—	dB
		Interferer CW at Desired ± 2 MHz	—	59.3	—	dB
		Interferer CW at Desired ± 5 MHz	—	71.6	—	dB
		Interferer CW at Desired ± 10 MHz ⁸	—	79.3	—	dB
		Interferer CW at Desired ± 100 MHz ⁸	—	82.2	—	dB
Blocking selectivity, 1% FER. Desired is 9.6 kbps 2FSK signal ⁷ at 3dB above sensitivity level, frequency = 908.42 MHz	C/I _{BLOCKER_9p6}	Interferer CW at Desired ± 1 MHz	—	54.3	—	dB
		Interferer CW at Desired ± 2 MHz	—	60.4	—	dB
		Interferer CW at Desired ± 5 MHz	—	72.7	—	dB
		Interferer CW at Desired ± 10 MHz ⁸	—	80.1	—	dB
		Interferer CW at Desired ± 100 MHz ⁸	—	83.5	—	dB
Blocking selectivity, 1% FER. Desired is reference 100 kbps O-QPSK signal ⁵ at -89 dBm level, 1% FER, frequency = 912 MHz ⁶	C/I _{BLOCKER_OQPSK}	Interferer CW at Desired ± 2 MHz	—	54.8	—	dB
		Interferer CW at Desired ± 5 MHz	—	60	—	dB
		Interferer CW at Desired ± 10 MHz	—	69.3	—	dB
		Interferer CW at Desired ± 100 MHz	—	88.1	—	dB
Intermod selectivity, 1% FER. CW interferers at 400 kHz and 800 kHz offsets	C/I _{IM}	Desired is 100 kbps GFSK signal ¹ at 3dB above sensitivity level, frequency = 916 MHz	—	31.0	—	dB
Upper limit of input power range over which RSSI resolution is maintained	RSSI _{MAX}		—	—	5	dBm
Lower limit of input power range over which RSSI resolution is maintained	RSSI _{MIN}		-98	—	—	dBm
RSSI resolution	RSSI _{RES}	Over RSSI _{MIN} to RSSI _{MAX} range	—	0.25	—	dBm
Max spurious emissions during active receive mode, per FCC Part 15.109(a)	SPUR _{RX_FCC}	216-960 MHz	—	-59.9	-49.2	dBm
		Above 960 MHz	—	-55.7	-41.2	dBm
Max spurious emissions during active receive mode, per ARIB STD-T108 Section 3.3	SPUR _{RX_ARIB}	Below 710 MHz, RBW=100kHz	—	-66.3	-54	dBm
		710-900 MHz, RBW=1MHz	—	-70.8	-55	dBm
		900-915 MHz, RBW=100kHz	—	-70.4	-55	dBm
		915-930 MHz, RBW=100kHz	—	-70.7	-55	dBm
		930-1000 MHz, RBW=100kHz	—	-70.8	-55	dBm
		Above 1000 MHz, RBW=1MHz	—	-69.3	-47	dBm

Parameter	Symbol	Test Condition	Min	Typ	Max	Unit
Note:						
1. Definition of reference signal is 100 kbps 2GFSK, BT=0.6, $\Delta f = 58$ kHz, NRZ, '0' = $F_{center} + \Delta f/2$, '1' = $F_{center} - \Delta f/2$						
2. Minimum Packet Error Rate floor will be ~0.5% for desired input signal levels between specified datasheet sensitivity level and -10dBm.						
3. Minimum Packet Error Rate floor will be ~ 1% for desired input signal levels > -10dBm.						
4. Definition of reference signal is 40 kbps 2FSK, $\Delta f = 40$ kHz, NRZ, '0' = $F_{center} + \Delta f/2$, '1' = $F_{center} - \Delta f/2$						
5. Definition of reference signals is 100 kbps O-QPSK, 800 kcps chip rate, 8x spreading factor, 32 bit chip length, 4 bits per symbol						
6. Measured using the Radio Interface with Balun for Z-Wave Long Range						
7. Definition of reference signal is 9.6 kbps 2FSK, $\Delta f = 40$ kHz, Manchester, '0' = Transition from ($F_{center} + 20k + \Delta f/2$), '1' = Transition from ($F_{center} + 20k - \Delta f/2$)						
8. Minimum Packet Error Rate floor for signals in presence of blocker will increase above 1% for blocker levels above -30dBm.						

4.1.7.4 Sub-GHz RF Transmitter characteristics for 868 MHz Band

Unless otherwise indicated, typical conditions are: T = 25 °C, VREGVDD = AVDD = IOVDD = 3.3 V, DVDD = RFVDD = External RF Supply. RFVDD and RF supply paths are filtered using ferrites. Crystal frequency = 39 MHz. RF frequency band 868 MHz.

Table 4.10. Sub-GHz RF Transmitter characteristics for 868 MHz Band

Parameter	Symbol	Test Condition	Min	Typ	Max	Unit
RF tuning frequency range	F_{RANGE}		863	—	876	MHz
Maximum TX Power ¹	$POUT_{MAX}$	13 dBm output power setting	—	14	—	dBm
Minimum active TX Power	$POUT_{MIN}$		—	-30	—	dBm
Output power step size	$POUT_{STEP}$	output power > 0 dBm	—	0.5	—	dB
Output power variation vs supply at $POUT_{MAX}$	$POUT_{VAR_V}$	1.8 V < $V_{VREGVDD}$ < 3.3 V, T = 25 °C	—	2.4	—	dB
Output power variation vs temperature, peak to peak	$POUT_{VAR_T}$	-40 to +85 °C	—	1.3	—	dB
Output power variation vs RF frequency	$POUT_{VAR_F}$	T = 25 °C, Over specified RF tuning frequency range	—	0.4	—	dB
Spurious emissions of harmonics, Conducted measurement, Test Frequency = 868.4 MHz	$SPUR_{HARM_ETSI}$	Per ETSI EN 300-220, Section 7.8.2.1	—	-39	-30	dBm
Spurious emissions out-of-band, Conducted measurement, Test Frequency = 868.4 MHz	$SPUR_{OOB_ETSI}$	Per ETSI EN 300-220, Section 7.8.2.1 (47-74 MHz, 87.5-118 MHz, 174-230 MHz, and 470-862 MHz)	—	-69.6	-54	dBm
		Per ETSI EN 300-220, Section 7.8.2.1 (other frequencies below 1 GHz)	—	-69.8	-36	dBm
		Per ETSI EN 300-220, Section 7.8.2.1 (frequencies above 1 GHz)	—	-64.9	-30	dBm

Note:

1. If a SAW filter is used, the output power is 2 - 3 dBm lower due to insertion loss. Always adjust the output power to match the limits set by the RF regulatory authorities for the region in which the device is used.

4.1.7.5 Sub-GHz RF Receiver Characteristics for 868 MHz Band

Unless otherwise indicated, typical conditions are: T = 25 °C, VREGVDD = AVDD = IOVDD = 3.3 V, DVDD = RFVDD = External RF Supply. RFVDD and RF supply paths are filtered using ferrites. Crystal frequency = 39 MHz. RF frequency band 868 MHz. Measured using the Radio Interface with IPD.

Table 4.11. Sub-GHz RF Receiver Characteristics for 868 MHz Band

Parameter	Symbol	Test Condition	Min	Typ	Max	Unit
Tuning frequency range	F _{RANGE}		863	—	876	MHz
Max usable input level, 1% FER	SAT _{100k}	Desired is reference 100 kbps GFSK signal ¹	—	10	—	dBm
Sensitivity ^{2 3}	SENS	Desired is reference 100 kbps GFSK signal ¹ , 1% FER, frequency = 869.85 MHz, T ≤ 85 °C	—	-98.6	—	dBm
		Desired is reference 40 kbps 2FSK signal ⁴ , 1% FER, frequency = 868.4 MHz, T ≤ 85 °C	—	-102.3	—	dBm
		Desired is reference 9.6 kbps 2FSK signal ⁵ , 1% FER, frequency = 868.42 MHz, T ≤ 85 °C	—	-103.3	—	dBm
Image rejection, Interferer is CW at image frequency	C/I _{IMAGE}	Desired is 100kbps GFSK signal ¹ at 3dB above sensitivity level, 1% FER, frequency = 869.85 MHz	—	33.6	—	dB
		Desired is reference 40 kbps 2FSK signal ⁴ at 3dB above sensitivity level, 1% FER, frequency = 868.4 MHz	—	35.4	—	dB
		Desired is reference 9.6 kbps 2FSK signal ⁵ at 3dB above sensitivity level, 1% FER, frequency = 868.42 MHz	—	35.5	—	dB
Blocking selectivity, 1% FER. Desired is 100 kbps GFSK signal ¹ at 3 dB above sensitivity level, frequency = 869.85 MHz	C/I _{BLOCKER_100}	Interferer CW at Desired ± 1 MHz	—	49.2	—	dB
		Interferer CW at Desired ± 2 MHz	—	55.6	—	dB
		Interferer CW at Desired ± 5 MHz	—	67.3	—	dB
		Interferer CW at Desired ± 10 MHz ⁶	—	74.3	—	dB
		Interferer CW at Desired ± 100 MHz ⁶	—	79.0	—	dB
Blocking selectivity, 1% FER. Desired is 40 kbps 2FSK signal ⁴ at 3 dB above sensitivity level, frequency = 868.4 MHz	C/I _{BLOCKER_40}	Interferer CW at Desired ± 1 MHz	—	53.4	—	dB
		Interferer CW at Desired ± 2 MHz	—	59.4	—	dB
		Interferer CW at Desired ± 5 MHz	—	71.9	—	dB
		Interferer CW at Desired ± 10 MHz ⁶	—	79.4	—	dB
		Interferer CW at Desired ± 100 MHz ⁶	—	83.2	—	dB

Parameter	Symbol	Test Condition	Min	Typ	Max	Unit
Blocking selectivity, 1% FER. Desired is 9.6 kbps 2FSK signal ⁵ at 3 dB above sensitivity level, frequency = 868.42 MHz	C/I _{BLOCKER_9p6}	Interferer CW at Desired ± 1 MHz	—	54.5	—	dB
		Interferer CW at Desired ± 2 MHz	—	60.4	—	dB
		Interferer CW at Desired ± 5 MHz	—	73.0	—	dB
		Interferer CW at Desired ± 10 MHz ⁶	—	80.0	—	dB
		Interferer CW at Desired ± 100 MHz ⁶	—	84.3	—	dB
Upper limit of input power range over which RSSI resolution is maintained	RSSI _{MAX}		—	—	5	dBm
Lower limit of input power range over which RSSI resolution is maintained	RSSI _{MIN}		-98	—	—	dBm
RSSI resolution	RSSI _{RES}	Over RSSI _{MIN} to RSSI _{MAX} range	—	0.25	—	dBm
Max spurious emissions during active receive mode	SPUR _{RX}	30 MHz to 1 GHz	—	-54.4	—	dBm
		1 GHz to 12 GHz	—	-63.8	—	dBm

Note:

1. Definition of reference signal is 100 kbps 2GFSK, BT=0.6, Δf = 58 kHz, NRZ, '0' = F_{center} + Δf/2, '1' = F_{center} - Δf/2
2. Minimum Packet Error Rate floor will be ~0.5% for desired input signal levels between specified datasheet sensitivity level and -10dBm.
3. Minimum Packet Error Rate floor will be ~ 1% for desired input signal levels > -10dBm.
4. Definition of reference signal is 40 kbps 2FSK, Δf = 40 kHz, NRZ, '0' = F_{center} + Δf/2, '1' = F_{center} - Δf/2
5. Definition of reference signal is 9.6 kbps 2FSK, Δf = 40 kHz, Manchester, '0' = Transition from (F_{center} + 20k + Δf/2), '1' = Transition from (F_{center} + 20k - Δf/2)
6. Minimum Packet Error Rate floor for signals in presence of blocker will increase above 1% for blocker levels above -30dBm.

4.1.8 High-Frequency Crystal Oscillator (HFXO)

Table 4.12. High-Frequency Crystal Oscillator (HFXO)

Parameter	Symbol	Test Condition	Min	Typ	Max	Unit
Crystal frequency ¹	f _{HFXO}		39	39	39	MHz
Frequency tolerance for the crystal	FT _{HFXO}	-40 to 85 °C, 5 years of aging	-25	—	25	ppm

Note:

1. Refer to the Z-Wave Hardware Implementation Guidelines for recommended crystals.

4.1.9 I/O Characteristics

Table 4.13. I/O Characteristics

Parameter	Symbol	Test Condition	Min	Typ	Max	Unit
Input low voltage	V_{IL}	All inputs	—	—	$IOVDD*0.3$	V
		RESETn	—	—	$AVDD*0.3$	V
Input high voltage	V_{IH}	All inputs	$IOVDD*0.7$	—	—	V
		RESETn	$AVDD*0.7$	—	—	V
Output high voltage relative to IOVDD	V_{OH}	Sourcing 20 mA, $IOVDD \geq 3$ V	$IOVDD*0.8$	—	—	V
		Sourcing 8 mA, $IOVDD \geq 1.62$ V	$IOVDD*0.6$	—	—	V
Output low voltage relative to IOVDD	V_{OL}	Sinking 20 mA, $IOVDD \geq 3$ V	—	—	$IOVDD*0.2$	V
		Sinking 8 mA, $IOVDD \geq 1.62$ V	—	—	$IOVDD*0.4$	V
Input leakage current	I_{IOLEAK}	Input pin voltage $\leq IOVDD$, $T \leq 85$ °C	—	0.1	30	nA
I/O pin pull-up/pull-down resistor ¹	R_{PUD}		30	40	65	k Ω
Pulse width of pulses removed by the glitch suppression filter	$t_{IOGLITCH}$		15	25	45	ns
Output fall time, From 70% to 30% of V_{IOVDD}	t_{IOOF}	All outputs, $C_L = 50$ pF	—	1.8	—	ns
Output rise time, From 30% to 70% of V_{IOVDD}	t_{IOOR}	All outputs, $C_L = 50$ pF	—	2.2	—	ns
RESETn low time to ensure pin reset	T_{RESET}		100	—	—	ns
Note:						
1. GPIO pull-ups are referenced to the IOVDD supply, except for RESETn, which connects to AVDD.						

4.2 Typical Performance Curves

Typical performance curves indicate typical characterized performance under the stated conditions.

4.2.1 Supply Current

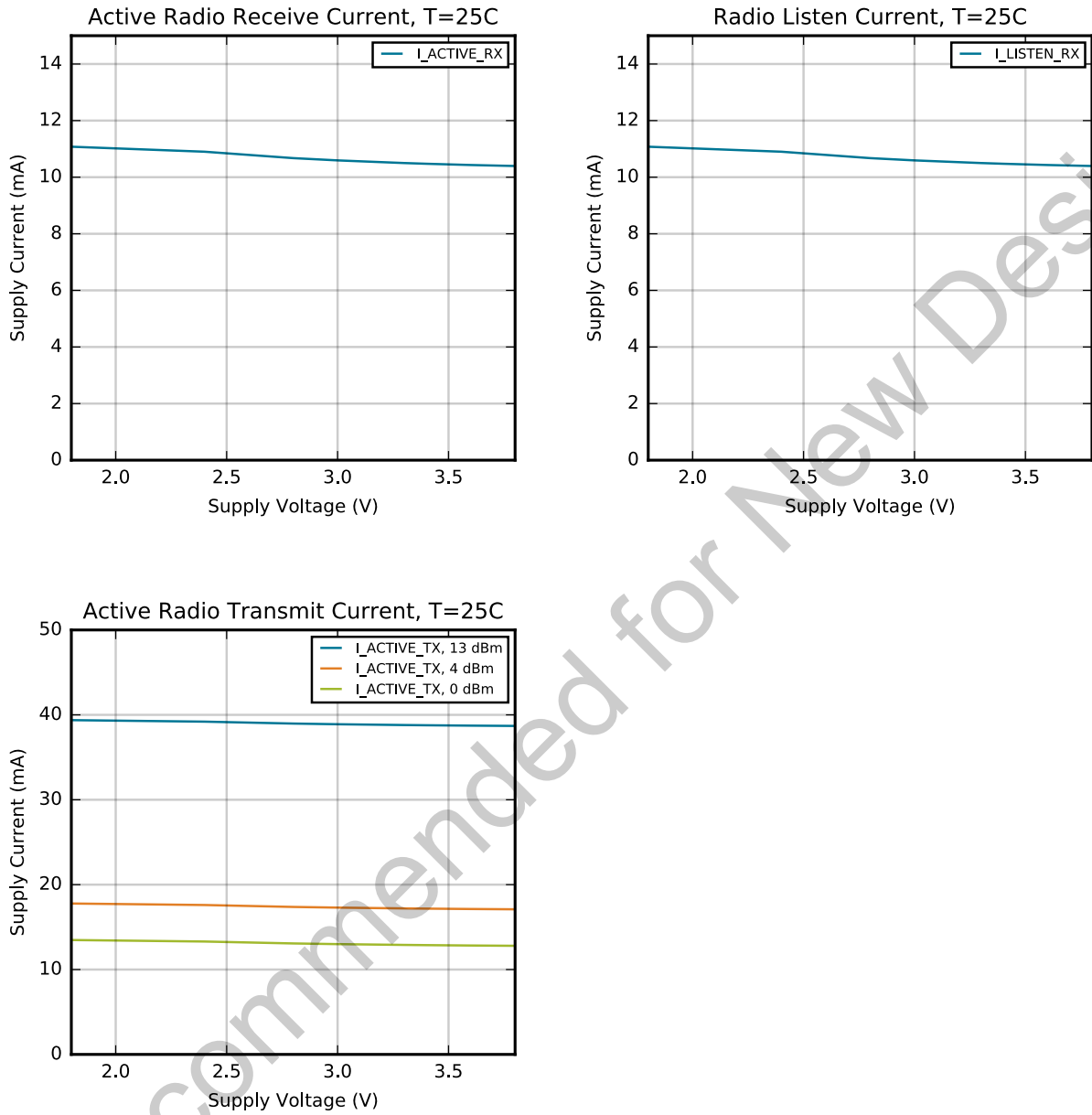

Figure 4.1. Supply Current vs. Supply Voltage

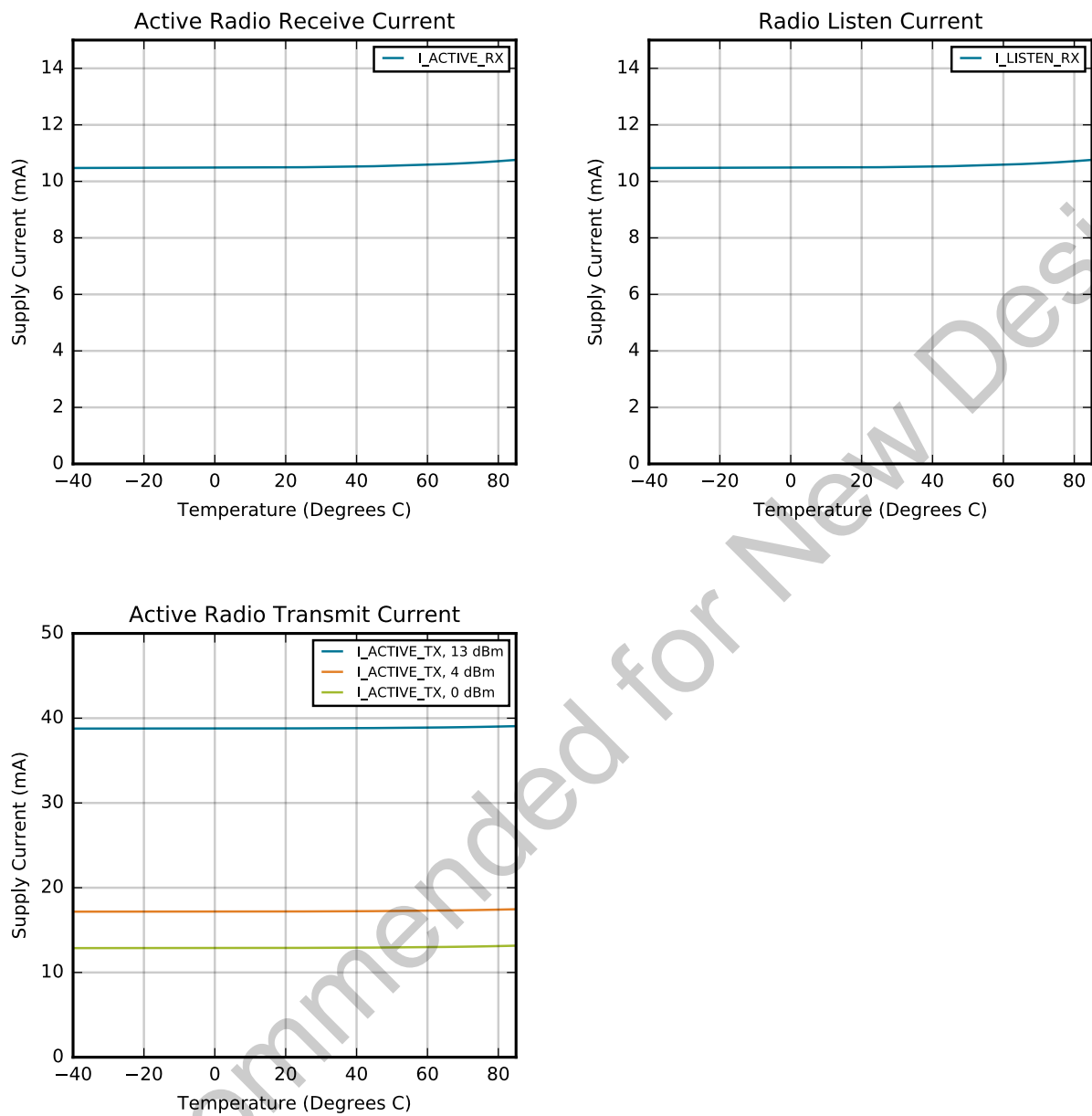

Figure 4.2. Supply Current vs. Temperature

4.2.2 Z-Wave Radio

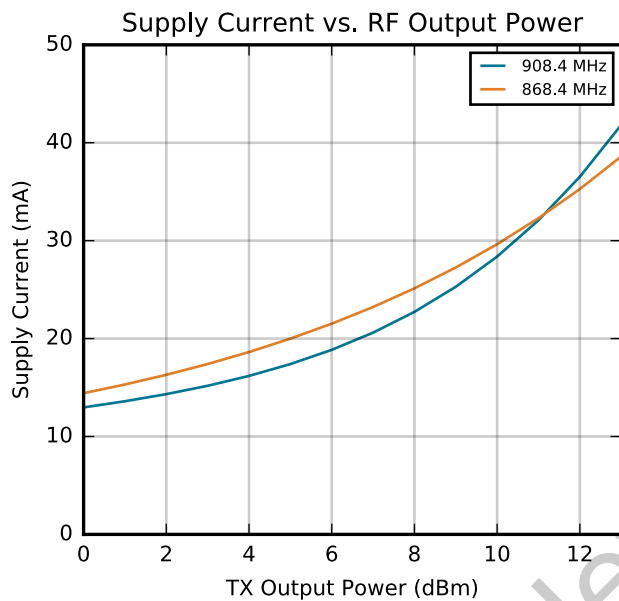

Figure 4.3. RF Transmitter Output Power

Not Recommended for New Designs

5. Typical Connection Diagrams

5.1 Z-Wave

Typical connections for implementing Z-Wave on EFR32ZG14 are shown in [Figure 5.1 Typical System Connections for Z-Wave with IPD on page 25](#). Refer to the design files for BRD4201 for more specific details on component choice.

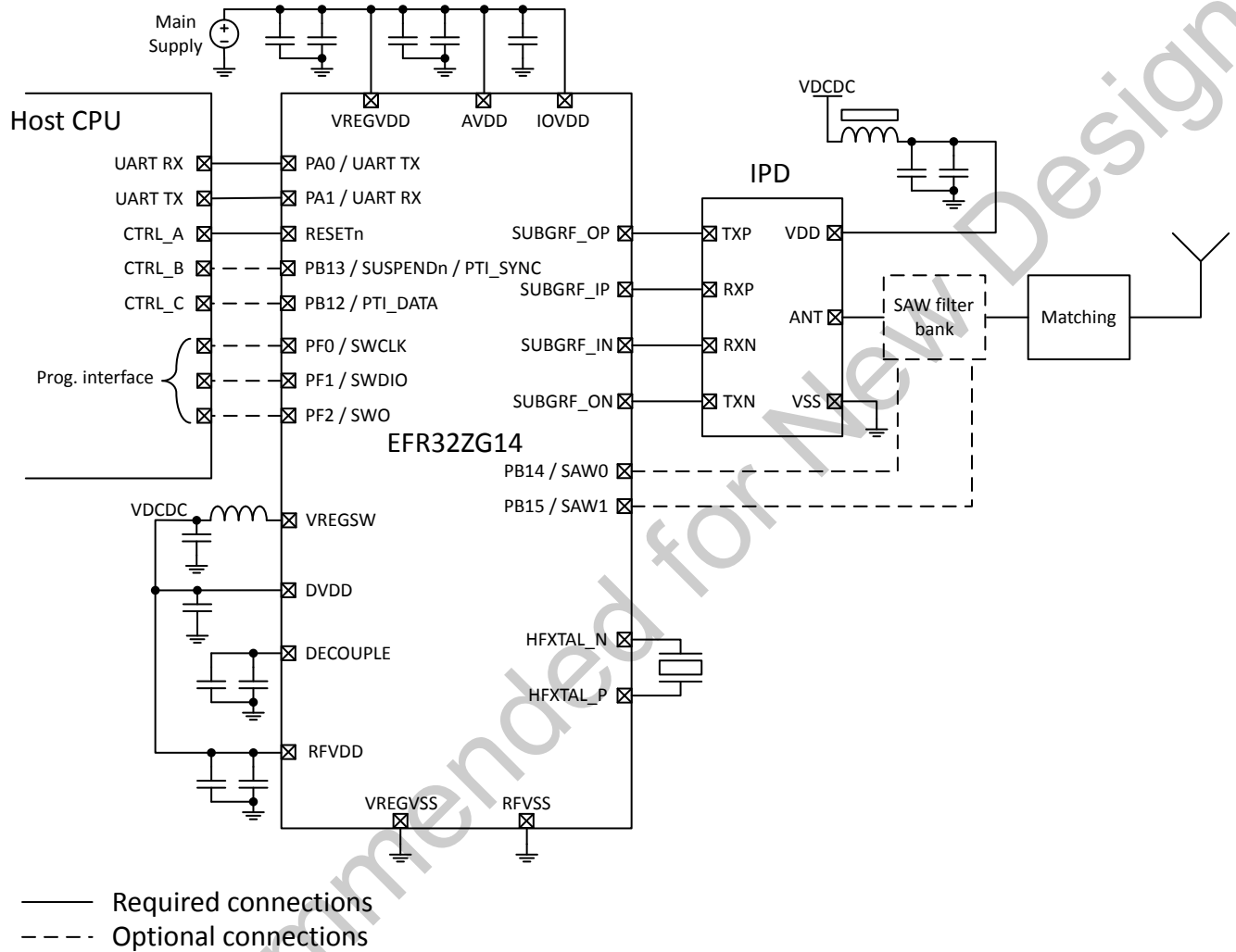

Figure 5.1. Typical System Connections for Z-Wave with IPD

5.2 Z-Wave Long Range

Typical connections for implementing Z-Wave Long Range on EFR32ZG14 are shown in Figure 5.2 Typical System Connections for Z-Wave Long Range on page 26. Refer to the design files for BRD4206 for more specific details on component choice.

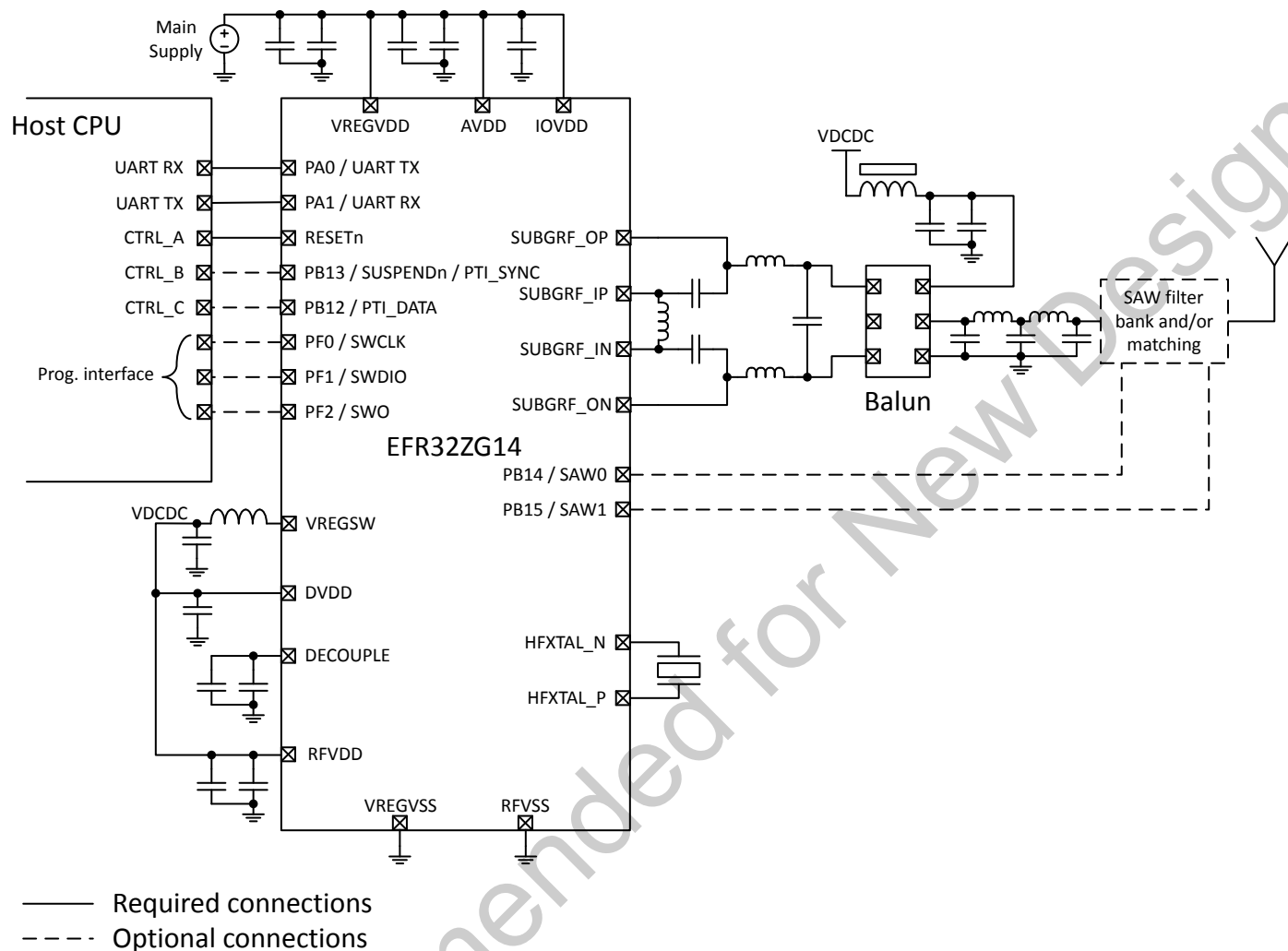

Figure 5.2. Typical System Connections for Z-Wave Long Range

6. EFR32ZG14 Device Pinout

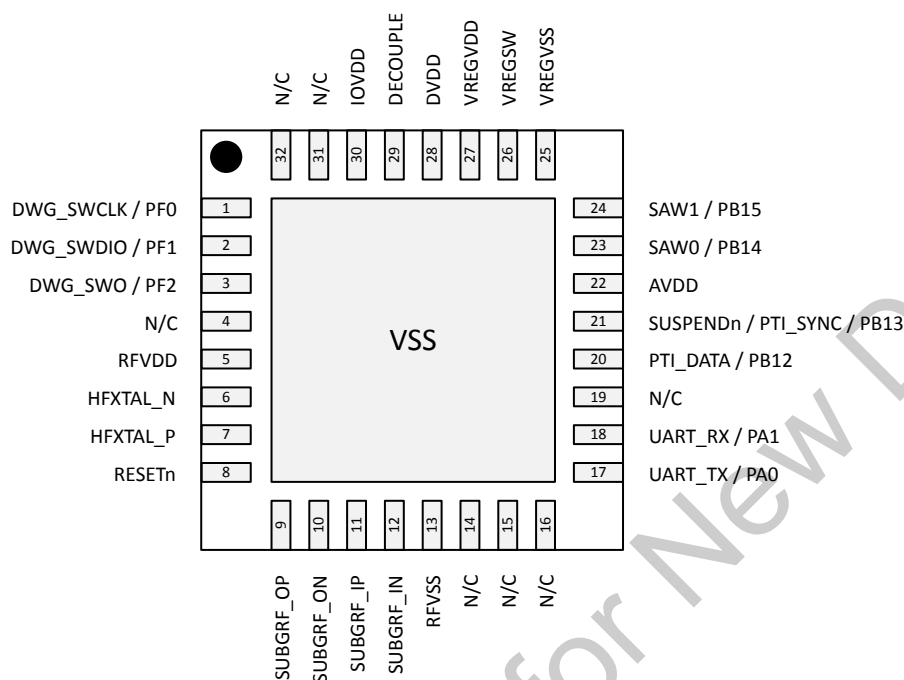

Figure 6.1. EFR32ZG14 Device Pinout

Table 6.1. EFR32ZG14 Device Pinout

Pin Name	Pin(s)	Description	Pin Name	Pin(s)	Description
VSS	0	Ground	PF0	1	DBG_SWCLK - Serial Wire Debug Clock
PF1	2	DBG_SWDIO - Serial Wire Debug Data I/O	PF2	3	DBG_SWO - Serial Wire Viewer Output
N/C	4, 14, 15, 16, 19, 31, 32	No Connect	RFVDD	5	Radio power supply
HFXTAL_N	6	High Frequency Crystal input pin.	HFXTAL_P	7	High Frequency Crystal output pin.
RESETn	8	Reset input, active low. To apply an external reset source to this pin, it is required to only drive this pin low during reset, and let the internal pull-up ensure that reset is released.	SUBGRF_OP	9	Sub GHz Differential RF output, positive path.
SUBGRF_ON	10	Sub GHz Differential RF output, negative path.	SUBGRF_IP	11	Sub GHz Differential RF input, positive path.

Pin Name	Pin(s)	Description	Pin Name	Pin(s)	Description
SUBGRF_IN	12	Sub GHz Differential RF input, negative path.	RFVSS	13	Radio Ground
PA0	17	UART_TX - UART Serial Data Output	PA1	18	UART_RX - UART Serial Data Input
PB12	20	PTI_DATA - Packet Trace Data	PB13	21	SUSPENDn / PTI_SYNC - Suspend Input, active low / Packet Trace Sync
AVDD	22	Analog power supply.	PB14	23	SAW0 - Saw Filter Select 0 Output
PB15	24	SAW1 - Saw Filter Select 1 Output	VREGVSS	25	Voltage regulator VSS
VREGSW	26	DCDC regulator switching node	VREGVDD	27	Voltage regulator VDD input
DVDD	28	Digital power supply.	DECOUPLE	29	Decouple output for on-chip voltage regulator. An external decoupling capacitor is required at this pin.
IOVDD	30	Digital IO power supply.			

Not Recommended for New Designs

7. QFN32 Package Specifications

7.1 QFN32 Package Dimensions

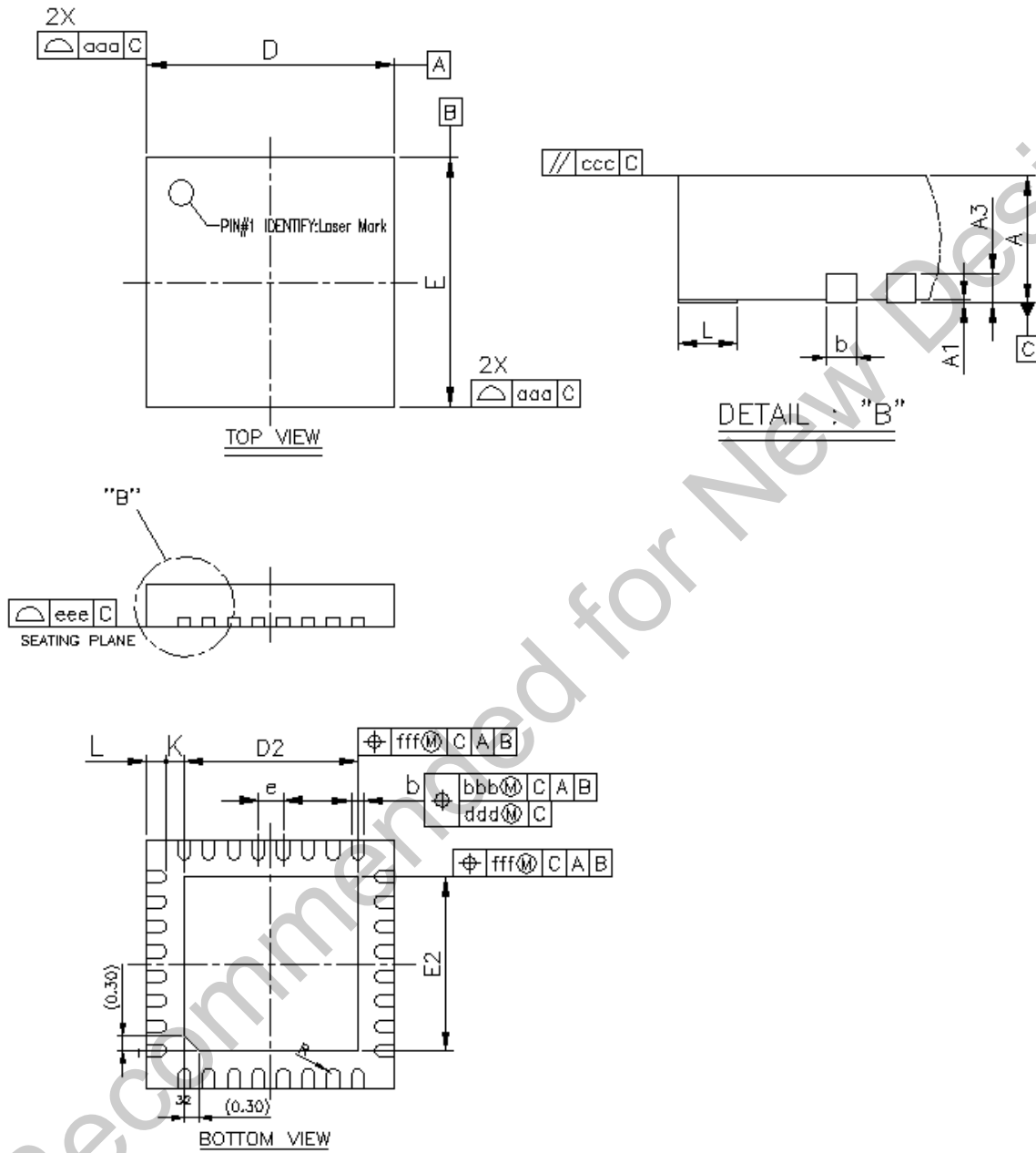

Figure 7.1. QFN32 Package Drawing

Table 7.1. QFN32 Package Dimensions

Dimension	Min	Typ	Max
A	0.80	0.85	0.90
A1	0.00	0.02	0.05
A3	0.20 REF		
b	0.18	0.25	0.30
D/E	4.90	5.00	5.10
D2/E2	3.40	3.50	3.60
E	0.50 BSC		
L	0.30	0.40	0.50
K	0.20	—	—
R	0.09	—	0.14
aaa	0.15		
bbb	0.10		
ccc	0.10		
ddd	0.05		
eee	0.08		
fff	0.10		

Note:

1. All dimensions shown are in millimeters (mm) unless otherwise noted.
2. Dimensioning and Tolerancing per ANSI Y14.5M-1994.
3. This drawing conforms to the JEDEC Solid State Outline MO-220, Variation VKKD-4.
4. Recommended card reflow profile is per the JEDEC/IPC J-STD-020 specification for Small Body Components.

7.2 QFN32 PCB Land Pattern

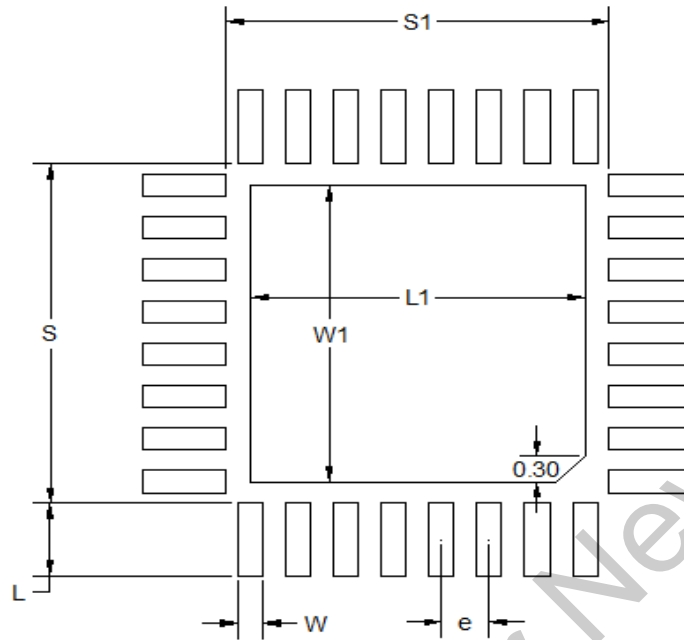

Figure 7.2. QFN32 PCB Land Pattern Drawing

Table 7.2. QFN32 PCB Land Pattern Dimensions

Dimension	Typ
S1	4.01
S	4.01
L1	3.50
W1	3.50
e	0.50
W	0.26
L	0.86

Note:

1. All dimensions shown are in millimeters (mm) unless otherwise noted.
2. This Land Pattern Design is based on the IPC-7351 guidelines.
3. All metal pads are to be non-solder mask defined (NSMD). Clearance between the solder mask and the metal pad is to be 60 µm minimum, all the way around the pad.
4. A stainless steel, laser-cut and electro-polished stencil with trapezoidal walls should be used to assure good solder paste release.
5. The stencil thickness should be 0.125 mm (5 mils).
6. The ratio of stencil aperture to land pad size can be 1:1 for all perimeter pads.
7. A 3x3 array of 0.85 mm square openings on a 1.00 mm pitch can be used for the center ground pad.
8. A No-Clean, Type-3 solder paste is recommended.
9. The recommended card reflow profile is per the JEDEC/IPC J-STD-020 specification for Small Body Components.

Note: Above notes and stencil design are shared as recommendations only. A customer or user may find it necessary to use different parameters and fine tune their SMT process as required for their application and tooling.

8. Revision History

Revision 1.2

June, 2022

- Updated [4.1.1 Absolute Maximum Ratings](#) absolute voltage of sub-GHz RF pins..
- Added timing specifications for RESETn low time and clarified V_{IL} and V_{IH} logic levels for RESETn pins in [Table 4.13 I/O Characteristics on page 21](#).
- Added a note to [Table 7.2 QFN32 PCB Land Pattern Dimensions on page 32](#).
- Removed all references to RFSENSE.

Revision 1.1

December 2020

- In [1. Feature List](#), updated MCU peripherals and GPIO
- In [2. Ordering Information](#), updated GPIO
- Updated maximum TX power to 14 dBm.
- Updated list of modulation formats. Removed 4 (G)FSK, added DSSS O-QPSK.
- In [3.3 Radio Interface](#) updated figure [Figure 3.2 Radio Interface with IPD on page 6](#) and added figure [Figure 3.3 Radio Interface with Balun for Z-Wave Long Range on page 6](#).
- In [3.4 Embedded Interface](#) updated active-low SUSPENDn signal and PTI interface signals, updated figure [Figure 3.4 Host Interface Connections on page 7](#).
- In [4.1.5 Current Consumption](#) updated current consumptions for 912 MHz O-QPSK
- In [4.1.7.1 Sub-GHz RF Transmitter characteristics for 915 MHz Band](#):
 - Corrected FCC reference for non-restricted bands in:
 - $SPUR_{HARM_FCC_14}$
 - $SPUR_{OOB_FCC_14}$
 - Corrected FCC reference for PSD
 - Added table for [4.1.7.2 Sub-GHz RF Transmitter characteristics for 915 MHz Band, +14 dBm](#)
- In [4.1.7.3 Sub-GHz RF Receiver Characteristics for 915 MHz Band](#), updated the maximum specification for $SPUR_{RX_ARIB}$, 930-1000 MHz, RBW=100 kHz. Added sensitivity, image rejection and blocking sensitivity for 912 MHz OQPSK PHY.
- In [5. Typical Connection Diagrams](#), updated figure and added another connection diagram for Z-Wave Long Range.
- In [6. EFR32ZG14 Device Pinout](#) updated figure and table [Table 6.1 EFR32ZG14 Device Pinout on page 27](#) for pin 20 and pin 21.

Revision 1.0

January 2019

- Updated electrical characteristics with latest characterization results.

Revision 0.2

December 2018

- Required crystal frequency changed to 39 MHz.
- Updated electrical characteristics with latest characterization estimates.
- [Table 4.7 Sub-GHz RF Transmitter characteristics for 915 MHz Band on page 13](#): PSD conditions updated to specify PSD at each data rate.

Revision 0.1

September, 2018

Initial release.

Simplicity Studio

One-click access to MCU and wireless tools, documentation, software, source code libraries & more. Available for Windows, Mac and Linux!



IoT Portfolio
www.silabs.com/IoT



SW/HW
www.silabs.com/simplicity



Quality
www.silabs.com/quality



Support & Community
www.silabs.com/community

Disclaimer

Silicon Labs intends to provide customers with the latest, accurate, and in-depth documentation of all peripherals and modules available for system and software implementers using or intending to use the Silicon Labs products. Characterization data, available modules and peripherals, memory sizes and memory addresses refer to each specific device, and "Typical" parameters provided can and do vary in different applications. Application examples described herein are for illustrative purposes only. Silicon Labs reserves the right to make changes without further notice to the product information, specifications, and descriptions herein, and does not give warranties as to the accuracy or completeness of the included information. Without prior notification, Silicon Labs may update product firmware during the manufacturing process for security or reliability reasons. Such changes will not alter the specifications or the performance of the product. Silicon Labs shall have no liability for the consequences of use of the information supplied in this document. This document does not imply or expressly grant any license to design or fabricate any integrated circuits. The products are not designed or authorized to be used within any FDA Class III devices, applications for which FDA premarket approval is required or Life Support Systems without the specific written consent of Silicon Labs. A "Life Support System" is any product or system intended to support or sustain life and/or health, which, if it fails, can be reasonably expected to result in significant personal injury or death. Silicon Labs products are not designed or authorized for military applications. Silicon Labs products shall under no circumstances be used in weapons of mass destruction including (but not limited to) nuclear, biological or chemical weapons, or missiles capable of delivering such weapons. Silicon Labs disclaims all express and implied warranties and shall not be responsible or liable for any injuries or damages related to use of a Silicon Labs product in such unauthorized applications.

Note: This content may contain offensive terminology that is now obsolete. Silicon Labs is replacing these terms with inclusive language wherever possible. For more information, visit www.silabs.com/about-us/inclusive-lexicon-project

Trademark Information

Silicon Laboratories Inc., Silicon Laboratories®, Silicon Labs®, SiLabs® and the Silicon Labs logo®, Bluegiga®, Bluegiga Logo®, EFM®, EFM32®, EFR, Ember®, Energy Micro, Energy Micro logo and combinations thereof, "the world's most energy friendly microcontrollers", Redpine Signals®, WiSeConnect, n-Link, ThreadArch®, EZLink®, EZRadio®, EZRadioPRO®, Gecko®, Gecko OS, Gecko OS Studio, Precision32®, Simplicity Studio®, Telegesis, the Telegesis Logo®, USBXpress®, Zentri, the Zentri logo and Zentri DMS, Z-Wave®, and others are trademarks or registered trademarks of Silicon Labs. ARM, CORTEX, Cortex-M3 and THUMB are trademarks or registered trademarks of ARM Holdings. Keil is a registered trademark of ARM Limited. Wi-Fi is a registered trademark of the Wi-Fi Alliance. All other products or brand names mentioned herein are trademarks of their respective holders.





Silicon Laboratories Inc.
400 West Cesar Chavez
Austin, TX 78701
USA

www.silabs.com

Looking for pricing, stock, or lifecycle information?

Click below to explore more details on WIN SOURCE:

-  [View EFR32ZG14P231F256GM32-B on WIN SOURCE](#)
-  [Silicon Labs Information](#)

Optimize Your Supply Chain with WIN SOURCE Solutions

-  Global Sourcing Solution
-  Obsolete Management
-  Cost Control Management
-  Shortage Management
-  Alternative Solution
-  Excess Inventory Management