

# CC2340R5-Q1 SimpleLink™ Bluetooth® Low Energy Wireless MCU

## 1 Features

### Wireless microcontroller

- AEC-Q100 Grade 2 qualified for automotive applications
- Optimized 48MHz Arm® Cortex®-M0+ processor
- 512KB of in-system programmable flash
- 12KB of ROM for bootloader and drivers
- 2.4GHz RF transceiver compatible with Bluetooth® 5.4 Low Energy
- Up to 64KB of ultra-low leakage SRAM. Full RAM retention in standby mode
- Integrated balun
- Supports over-the-air upgrade (OTA)
- Serial wire debug (SWD)

### Low power consumption

- MCU consumption:
  - 2.6mA active mode, CoreMark®
  - 53µA/MHz running CoreMark®
  - < 710nA standby mode, RTC, 64KB RAM
  - 165nA shutdown mode, wake-up on pin
- Radio consumption:
  - 5.3mA RX
  - 5.1mA TX at 0dBm
  - < 11.0mA TX at +8dBm

### Wireless protocol support

- [Bluetooth® 5.4 Low Energy](#)

### High-performance radio

- –102dBm for Bluetooth® Low Energy 125kbps
- –96.5dBm for Bluetooth® Low Energy 1Mbps
- Output power up to +8dBm with temperature compensation

### Regulatory compliance

- Suitable for systems targeting compliance with these standards:
  - EN 300 328 (Europe)
  - FCC CFR47 Part 15
  - ARIB STD-T66 (Japan)

### MCU peripherals

- 19 I/O Pads
  - 2 IO pads SWD, muxed with GPIOs
  - 2 IO pads LFXT, muxed with GPIOs
  - 15 DIOs (analog or digital IOs)
- 3 × 16-bit and 1 × 24-bit general-purpose timers, quadrature decode mode support

- 12-bit ADC, 1.2MSPS with external reference, 267kSPS with internal reference, eight external ADC inputs
- 1 × low-power comparator
- 1 × UART
- 1 × SPI
- 1 × I<sup>2</sup>C
- Real-time clock (RTC)
- Integrated temperature and battery monitor
- Watchdog timer

### Security enablers

- AES 128-bit cryptographic accelerator
- Random number generator from on-chip analog noise

### Product Cybersecurity Compliance

- ISO 21434 compliant (Cybersecurity Assurance Level 2)
- Developed for cybersecurity-relevant applications
- Documentation available to aid cybersecurity system design

### Development tools and software

- [LP-EM-CC2340R5 LaunchPad Development Kit](#)
- [SimpleLink™ CC23xx Software Development Kit \(SDK\)](#)
- [SmartRF™ Studio](#) for simple radio configuration
- [SysConfig](#) system configuration tool

### Operating range

- On-chip buck DC/DC converter
- 1.71V to 3.8V single supply voltage
- T<sub>j</sub>: –40 to +125°C
- HBM ESD Classification Level 2 (ESD CDM level 1C on RF pin, per AEC-Q100 Rev. J)
- CDM ESD Classification Level 2A (ESD CDM level C1 on RF pin, per AEC-Q100 Rev. J)

### RoHS-compliant package

- 5mm × 5mm RHB QFN32 with wettable flanks (19 GPIOs)



## 2 Applications

- [Automotive](#)
  - [Car access and security systems](#)

- [Passive entry passive start \(PEPS\)](#)
- [Remote keyless entry \(RKE\)](#)
  - [Advanced driver assistance systems \(ADAS\)](#)
  - [Tire pressure monitoring systems \(TPMS\)](#)

## 3 Description

The SimpleLink™ CC2340R5-Q1 device is an AEC-Q100 compliant wireless microcontroller (MCU) targeting [Bluetooth 5 Low Energy](#) automotive applications. The device is optimized for low-power wireless communication in applications such as tire pressure monitoring systems (TPMS), car access, including key fobs used in [passive entry passive start \(PEPS\)](#) and [remote keyless entry \(RKE\)](#), cable replacement, and smartphone connectivity. The highlighted features of this device include:

- Support for Bluetooth 5 features: high-speed mode (2Mbps PHY), long-range (LE Coded 125kbps and 500kbps PHYs), privacy 1.2.1 and channel selection algorithm #2, as well as backward compatibility and support for key features from the Bluetooth 4.2 and earlier Low Energy specifications.
- Fully qualified Bluetooth 5.4 software protocol stack included with the [SimpleLink™ CC23xx Software Development Kit \(SDK\)](#)
- Ultra-low standby current less than 0.71µA with RTC operational and full RAM retention that enables significant battery life extension, especially for applications with longer sleep intervals.
- Integrated balun for reduced bill-of-material (BOM) board layout
- Excellent radio sensitivity and robustness (selectivity and blocking) performance for Bluetooth Low Energy (–102dBm for 125kbps LE Coded PHY, with integrated balun)

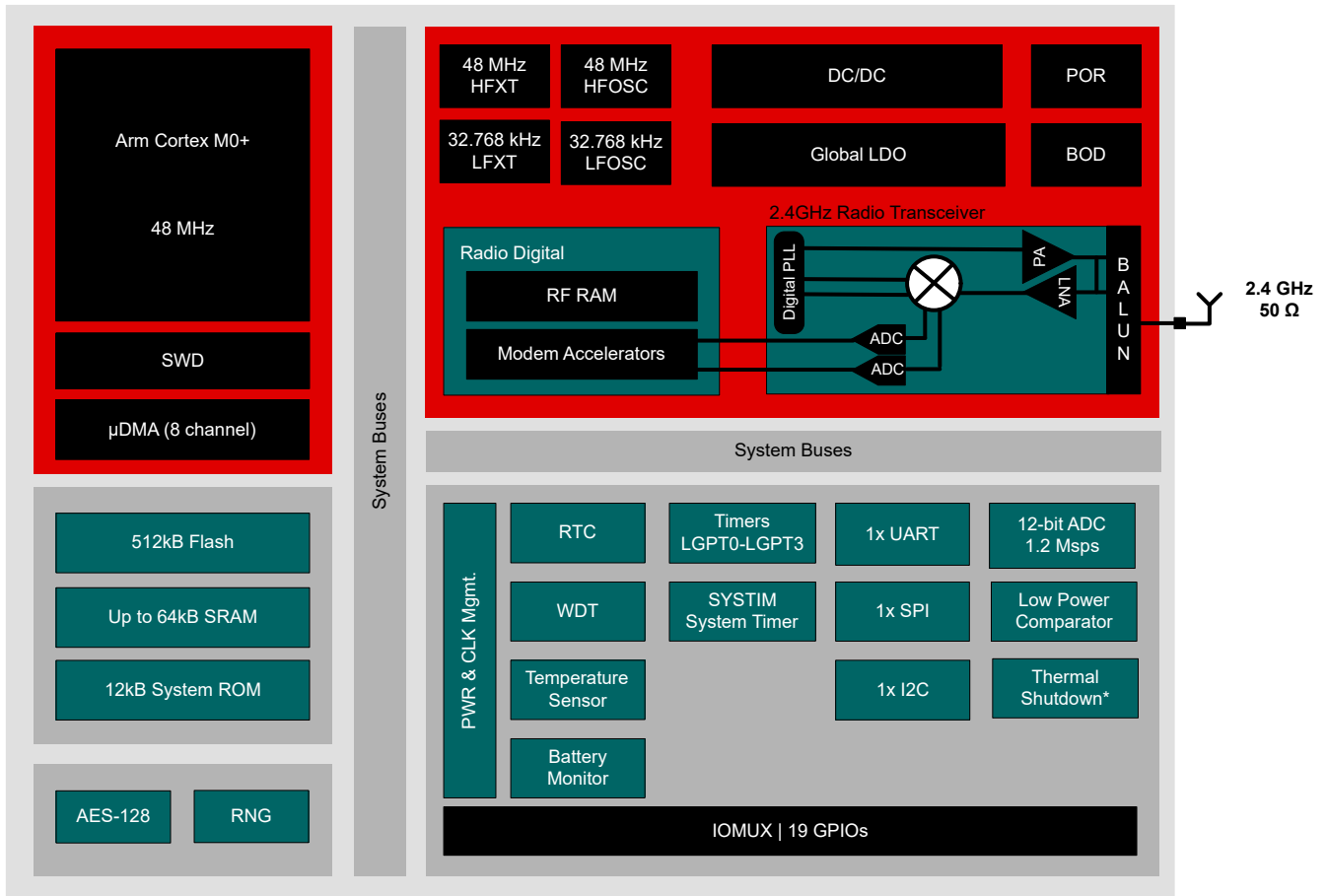
The CC2340R5-Q1 device is part of the SimpleLink™ MCU platform, which consists of Wi-Fi, Bluetooth Low Energy, Thread, Zigbee, Sub1GHz MCUs, and host MCUs that all share a common, easy-to-use development environment with a single core software development kit (SDK) and rich tool set. A one-time integration of the SimpleLink™ platform enables you to add any combination of the portfolio's devices into your design, allowing 100 percent code reuse when your design requirements change. For more information, visit [SimpleLink™ MCU platform](#).

### Device Information

PART NUMBER <sup>(1)</sup>	FLASH	RAM	TEMPERATURE RANGE	PACKAGE	PACKAGE SIZE
CC2340R52E0WRHBRQ1	512KB	36KB	–40°C–125°C	QFN32	5.00mm × 5.00mm
CC2340R53E0WRHBRQ1	512KB	64KB	–40°C–125°C	QFN32	5.00mm × 5.00mm

(1) For more information, see [Section 12](#).

## 4 Functional Block Diagram



- \* Refer to the [Device Comparison](#) table for availability of the thermal shutdown feature.

**Figure 4-1. CC2340R5-Q1 Block Diagram**

## Table of Contents

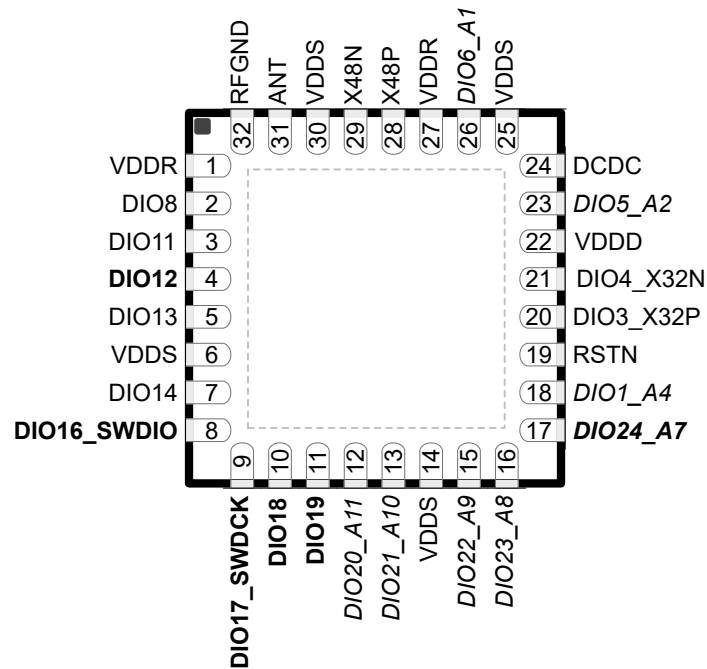
<b>1 Features</b> .....	1	7.19 Peripheral Characteristics.....	26
<b>2 Applications</b> .....	2	7.20 Typical Characteristics.....	33
<b>3 Description</b> .....	2	<b>8 Detailed Description</b> .....	41
<b>4 Functional Block Diagram</b> .....	3	8.1 Overview.....	41
<b>5 Device Comparison</b> .....	5	8.2 System CPU.....	41
<b>6 Pin Configuration and Functions</b> .....	6	8.3 Radio (RF Core).....	42
6.1 Pin Diagram—RHB Package (Top View).....	6	8.4 Memory.....	42
6.2 Signal Descriptions—RHB Package.....	7	8.5 Cryptography.....	43
6.3 Connections for Unused Pins and Modules— RHB Package.....	8	8.6 Timers.....	43
6.4 RHB Peripheral Pin Mapping.....	8	8.7 Serial Peripherals and I/O.....	44
6.5 RHB Peripheral Signal Descriptions.....	12	8.8 Battery and Temperature Monitor.....	45
<b>7 Specifications</b> .....	17	8.9 $\mu$ DMA.....	45
7.1 Absolute Maximum Ratings.....	17	8.10 Debug.....	45
7.2 ESD Ratings.....	17	8.11 Power Management.....	46
7.3 Recommended Operating Conditions.....	17	8.12 Clock Systems.....	47
7.4 DCDC.....	17	8.13 Network Processor.....	47
7.5 Global LDO (GLDO).....	18	<b>9 Application, Implementation, and Layout</b> .....	48
7.6 Power Supply and Modules.....	18	9.1 Reference Designs.....	48
7.7 Battery Monitor.....	18	9.2 Junction Temperature Calculation.....	49
7.8 Temperature Sensor.....	18	<b>10 Device and Documentation Support</b> .....	50
7.9 Power Consumption—Power Modes.....	19	10.1 Device Nomenclature.....	50
7.10 Power Consumption—Radio Modes.....	20	10.2 Tools and Software.....	50
7.11 Nonvolatile (Flash) Memory Characteristics.....	20	10.3 Documentation Support.....	52
7.12 Thermal Resistance Characteristics.....	20	10.4 Support Resources.....	52
7.13 Thermal Shutdown.....	21	10.5 Trademarks.....	52
7.14 RF Frequency Bands.....	21	10.6 Electrostatic Discharge Caution.....	53
7.15 Bluetooth Low Energy—Receive (RX).....	21	10.7 Glossary.....	53
7.16 Bluetooth Low Energy—Transmit (TX).....	24	<b>11 Revision History</b> .....	53
7.17 2.4GHz RX/TX CW.....	24	<b>12 Mechanical, Packaging, and Orderable Information</b> .....	54
7.18 Timing and Switching Characteristics.....	24		

## 5 Device Comparison

Device	RADIO SUPPORT		FLASH (KB)	RAM + Cache (KB)	GPIO	Thermal Shutdown	PACKAGE SIZE
	Bluetooth® LE	+20dBm PA					5mm x 5mm VQFN (32)
CC2340R52-Q1	X		512	36	19	X	X
CC2340R53-Q1	X		512	64	19		X

## 6 Pin Configuration and Functions

### 6.1 Pin Diagram—RHB Package (Top View)



**Figure 6-1. RHB (5mm × 5mm) Pinout, 0.5mm Pitch (Top View)**

The following I/O pins marked in [Figure 6-1](#) in **bold** have high-drive capabilities:

- Pin 4, **DIO12**
- Pin 8, **DIO16\_SWDIO**
- Pin 9, **DIO17\_SWDCK**
- Pin 10, **DIO18**
- Pin 11, **DIO19**
- Pin 17, **DIO24\_A7**

The following I/O pins marked in [Figure 6-1](#) in *italics* have analog capabilities:

- Pin 12, *DIO20\_A11*
- Pin 13, *DIO21\_A10*
- Pin 15, *DIO22\_A9*
- Pin 16, *DIO23\_A8*
- Pin 17, *DIO24\_A7*
- Pin 18, *DIO1\_A4*
- Pin 23, *DIO5\_A2*
- Pin 26, *DIO6\_A1*

## 6.2 Signal Descriptions—RHB Package

**Table 6-1. Signal Descriptions—RHB Package**

PIN		I/O	TYPE	DESCRIPTION
NAME	NO.			
EGP	—	—	GND	Ground—exposed ground pad <sup>(1)</sup>
VDDR	1	—	Power	Internal 1.5V supply, must be powered from the internal DC/DC converter or the internal LDO <sup>(2) (3) (4)</sup>
DIO8	2	I/O	Digital	GPIO
DIO11	3	I/O	Digital	GPIO
DIO12	4	I/O	Digital	GPIO, high-drive capability
DIO13	5	I/O	Digital	GPIO
VDDS	6	—	Power	1.71V to 3.8V DIO supply <sup>(5)</sup>
DIO14	7	I/O	Digital	GPIO
DIO16_SWDIO	8	I/O	Digital	GPIO, SWD interface: mode select or SWDIO, high-drive capability
DIO17_SWDCK	9	I/O	Digital	GPIO, SWD interface: clock, high-drive capability
DIO18	10	I/O	Digital	GPIO, high-drive capability
DIO19	11	I/O	Digital	GPIO, high-drive capability
DIO20_A11	12	I/O	Digital or Analog	GPIO, analog capability
DIO21_A10	13	I/O	Digital or Analog	GPIO, analog capability
VDDS	14	—	Power	1.71V to 3.8V DIO supply <sup>(5)</sup>
DIO22_A9	15	I/O	Digital or Analog	GPIO, analog capability
DIO23_A8	16	I/O	Digital or Analog	GPIO, analog capability
DIO24_A7	17	I/O	Digital or Analog	GPIO, analog capability, high-drive capability
DIO1_A4	18	I/O	Digital or Analog	GPIO, analog capability
RSTN	19	I	Digital	Reset, active low. No internal pullup resistor
DIO3_X32P	20	I/O	Digital or Analog	GPIO, 32kHz crystal oscillator pin 1, Optional TCXO input
DIO4_X32N	21	I/O	Digital or Analog	GPIO, 32kHz crystal oscillator pin 2
VDDD	22	—	Power	For decoupling of internal 1.28V regulated core-supply. Connect an external 1μF decoupling capacitor. <sup>(2)</sup>
DIO5_A2	23	I/O	Digital or Analog	GPIO, analog capability
DCDC	24	—	Power	Switching node of internal DC/DC converter <sup>(5)</sup>
VDDS	25	—	Power	1.71V to 3.8V analog supply <sup>(5)</sup>
DIO6_A1	26	I/O	Digital or Analog	GPIO, analog capability
VDDR	27	—	Power	Internal 1.5V supply, must be powered from the internal DC/DC converter or the internal LDO. Connect an external 10μF decoupling capacitor. <sup>(2) (3) (4)</sup>
X48P	28	—	Analog	48MHz crystal oscillator pin 1
X48N	29	—	Analog	48MHz crystal oscillator pin 2
VDDS	30	—	Power	1.71V to 3.8V analog supply <sup>(5)</sup>
ANT	31	I/O	RF	2.4GHz TX, RX
RFGND	32	—	RFGND	RF Ground

- (1) EPG is the only non-RF ground connection for the device. A good electrical connection to the device ground on a printed circuit board (PCB) is imperative for proper device operation.
- (2) Do not supply external circuitry from this pin.
- (3) VDDR pins 1 and 27 must be tied together on the PCB.
- (4) Output from internal DC/DC and LDO is trimmed to 1.5V.
- (5) For more details, see the technical reference manual listed in [Section 10.3](#).

### 6.3 Connections for Unused Pins and Modules—RHB Package

**Table 6-2. Connections for Unused Pins—RHB Package**

FUNCTION	SIGNAL NAME	PIN NUMBER	ACCEPTABLE PRACTICE <sup>(1)</sup>	PREFERRED PRACTICE <sup>(1)</sup>
GPIO (digital)	DIO <sub>n</sub>	2–5 7 10–11	NC, GND, or VDD5	NC
SWD	DIO16_SWDIO	8	NC, GND, or VDD5	GND or VDD5
	DIO17_SWDCCK	9	NC, GND, or VDD5	GND or VDD5
GPIO (digital or analog)	DIO <sub>n</sub> _Am	12–13 15–18 23 26	NC, GND, or VDD5	NC
32.768kHz crystal	DIO3_X32P	20	NC or GND	NC
	DIO4_X32N	21		
DC/DC converter <sup>(2)</sup>	DCDC	24	NC	NC
	VDD5	6, 14, 25, 30	VDD5	VDD5

(1) NC = No connect

(2) When the DC/DC converter is not used, the inductor between DCDC and VDDR can be removed. VDDR must still be connected, and the 10µF DCDC capacitor must be kept on the VDDR net.

### 6.4 RHB Peripheral Pin Mapping

**Table 6-3. RHB (QFN32) Peripheral Pin Mapping**

PIN NO. QFN32	PIN NAME	SIGNAL NAME	SIGNAL TYPE	PIN MUX ENCODING	SIGNAL DIRECTION
1	VDDR	VDDR	—	N/A	N/A
2	DIO8	GPIO8	I/O	0	I/O
		SPI0SCLK		1	I/O
		UART0RTS		2	O
		T1C0N		3	O
		I2C0SDA		4	I/O
		T0C0N		5	O
		DTB3		7	O
3	DIO11	GPIO11	I/O	0	I/O
		SPI0CSN		1	I/O
		T1C2N		2	O
		T0C0		3	O
		LRFD0		4	O
		SPI0POCI		5	I/O
		DTB9		7	O
4	DIO12	GPIO12	I/O	0	I/O
		SPI0POCI		1	I/O
		SPI0PICO		2	I/O
		UART0RXD		3	I
		T1C1		4	O
		I2C0SDA		5	I/O
		DTB13		7	O

**Table 6-3. RHB (QFN32) Peripheral Pin Mapping (continued)**

PIN NO. QFN32	PIN NAME	SIGNAL NAME	SIGNAL TYPE	PIN MUX ENCODING	SIGNAL DIRECTION
5	DIO13	GPIO13	I/O	0	I/O
		SPI0POCI		1	I/O
		SPI0PICO		2	I/O
		UART0TXD		3	O
		T0C0N		4	O
		T1F		5	O
		DTB4		7	O
6	VDDS	VDDS	—	N/A	N/A
7	DIO14	DIO14	I/O	0	N/A
		T3C2		1	O
		T1C2N		2	O
		LRFD5		3	O
		T1F		4	O
8	DIO16_SWDI O	GPIO16	I/O	0	I/O
		SPI0PICO		1	I/O
		UART0RXD		2	I
		I2C0SDA		3	I/O
		T1C2		4	O
		T1C0N		5	O
		DTB10		7	O
9	DIO17_SWDC K	GPIO17	I/O	0	I/O
		SPI0SCLK		1	I/O
		UART0TXD		2	O
		I2C0SCL		3	I/O
		T1C1N		4	O
		T0C2		5	O
		DTB11		7	O
10	DIO18	GPIO18	I/O	0	I/O
		T3C0		1	O
		LPCO		2	O
		UART0TXD		3	O
		SPI0SCLK		4	I/O
		DTB12		7	O
11	DIO19	GPIO19	I/O	0	I/O
		T3C1		1	O
		T2PE		2	O
		SPI0PICO		4	I/O
		DTB0		7	O

**Table 6-3. RHB (QFN32) Peripheral Pin Mapping (continued)**

PIN NO. QFN32	PIN NAME	SIGNAL NAME	SIGNAL TYPE	PIN MUX ENCODING	SIGNAL DIRECTION
12	DIO20_A11	GPIO20	I/O	0	I/O
		LPCO		1	O
		UART0TXD		2	O
		UART0RXD		3	I
		T1C0		4	O
		SPI0POCI		5	I/O
		ADC11		6	I
		DTB14		7	O
13	DIO21_A10	GPIO21	I/O	0	I/O
		UART0CTS		1	I
		T1C1N		2	O
		T0C1		3	O
		SPI0POCI		4	I/O
		LRFD1		5	O
		ADC10/LPC+		6	I
		DTB15		7	O
14	VDDS	VDDS	—	N/A	N/A
15	DIO22_A9	GPIO22	I/O	0	I/O
		T2C0		1	O
		UART0RXD		2	I
		T3C1N		3	O
		ADC9		6	I
		DTB1		7	O
16	DIO23_A8	GPIO23	I/O	0	I/O
		T2C1		1	O
		T3C2N		3	O
		ADC8/LPC+/LPC-		6	I
17	DIO24_A7	GPIO24	I/O	0	I/O
		SPI0SCLK		1	I/O
		T1C0		2	O
		T3C0		3	O
		T0PE		4	O
		I2C0SCL		5	I/O
		ADC7/LPC+/LPC-		6	I
		DTB5		7	O
18	DIO1_A4	GPIO1	I/O	0	I/O
		T3C1		1	O
		LRFD7		2	O
		T1F		3	O
		UART0RTS		4	O
		ADC4		5	I
		DTB2		6	O
19	RTSN	RSTN	—	N/A	N/A

**Table 6-3. RHB (QFN32) Peripheral Pin Mapping (continued)**

PIN NO. QFN32	PIN NAME	SIGNAL NAME	SIGNAL TYPE	PIN MUX ENCODING	SIGNAL DIRECTION
20	DIO3_X32P	GPIO3	I/O	0	I/O
		LFCI		1	I
		T0C1N		2	O
		LRFD0		3	O
		T3C1		4	O
		T1C2		5	O
		LFXT_P		6	I
		DTB7		7	O
21	DIO4_X32N	GPIO4		0	I/O
		T0C2N		1	O
		UART0TXD		2	O
		LRFD1		3	O
		SPI0PICO		4	I/O
		T0C2		5	O
		LFXT_N		6	I
		DTB8		7	O
22	VDDD	VDDD	—	N/A	N/A
23	DIO5_A2	GPIO5	I/O	1	I/O
		T2C2		2	O
		LRFD6		3	O
		ADC2		6	I
24	DCDC	DCDC	—	N/A	N/A
25	VDDS	VDDS	—	N/A	N/A
26	DIO6_A1	GPIO6	I/O	0	I/O
		SPI0CSN		1	I/O
		I2C0SCL		2	I/O
		T1C2		3	O
		LRFD2		4	O
		UART0TXD		5	O
		ADC1/AREF+		6	I
		DTB6		7	O
27	VDDR	VDDR	—	N/A	N/A
28	X48P	X48P	—	N/A	N/A
29	X48N	X48N	—	N/A	N/A
30	VDDS	VDDS	—	N/A	N/A
31	ANT	ANT	—	N/A	N/A
32	RFGND	RFGND	—	N/A	N/A
		GND_TAB	—	N/A	N/A

## 6.5 RHB Peripheral Signal Descriptions

**Table 6-4. RHB (QFN32) Peripheral Signal Descriptions**

FUNCTION	SIGNAL NAME	Pin No.	PIN TYPE	SIGNAL DIRECTION	DESCRIPTION
		QFN32			
ADC	ADC11	12	I/O	I	HP ADC channel 11 input
	ADC10	13			HP ADC channel 10 input
	ADC9	15			HP ADC channel 9 input
	ADC8	16			HP ADC channel 8 input
	ADC7	17			HP ADC channel 7 input
	ADC6	—			ADC channel 6 input
	ADC5	—			ADC channel 5 input
	ADC4	18			ADC channel 4 input
	ADC3	—			ADC channel 3 input
	ADC2	23			ADC channel 2 input
	ADC1	26			HP ADC channel 1 input
	ADC0	—			HP ADC channel 0 input
	ADC Reference	AREF+			26
AREF-		0	ADC external voltage reference, negative terminal		
Analog Test Bus	ATEST0	12	I/O	O	Analog test bus output 0
	ATEST1	13			Analog test bus output 1
	FLTP3	13	I/O	O	Flash testpad output 3
	FLTP1	19			Flash testpad output 1
Clock	X32P	20	I/O	I	32kHz crystal oscillator pin 1, Optional TCXO input
	X32N	21	I/O	I	32kHz crystal oscillator pin 2
	X48P	28	—	I	48MHz crystal oscillator pin 1
	X48N	29	—	I	48MHz crystal oscillator pin 2
	CLKMIN	—	I/O	I	TDC or HFOSC tracking loop reference clock input
	LFCI	20	I/O	I	Low frequency clock input (LFXT bypass clock from pin)
Comparator	LPC0	—	I/O	O	Low power comparator output
		10			
		12			
Comparator Input	LPC+	13	I/O	I	Low power comparator positive input terminal
		16			
		17			
	LPC-	16			Lower power comparator negative input terminal
		17			

**Table 6-4. RHB (QFN32) Peripheral Signal Descriptions (continued)**

FUNCTION	SIGNAL NAME	Pin No.	PIN TYPE	SIGNAL DIRECTION	DESCRIPTION
		QFN32			
Digital Test Bus	DTB3	2	I/O	O	Digital test bus output 3
	DTB9	3			Digital test bus output 9
	DTB0	11			Digital test bus output 0
	DTB4	5			Digital test bus output 4
	DTB10	8			Digital test bus output 10
	DTB11	9			Digital test bus output 11
	DTB12	10			Digital test bus output 12
	DTB13	4			Digital test bus output 13
	DTB1	15			Digital test bus output 1
	DTB2	18			Digital test bus output 2
	DTB14	12			Digital test bus output 14
	DTB5	17			Digital test bus output 5
	DTB15	13			Digital test bus output 15
	DTB7	20			Digital test bus output 7
	DTB8	21			Digital test bus output 8
	DTB6	26			Digital test bus output 6
GPIO	GPIO8	2	I/O	I/O	General-purpose input or output
	GPIO9	—			
	GPIO10	—			
	GPIO11	3			
	GPIO12	4			
	GPIO13	5			
	GPIO14	7			
	GPIO15	—			
	GPIO16	8			
	GPIO27	9			
	GPIO18	10			
	GPIO19	11			
	GPIO20	12			
	GPIO21	13			
	GPIO22	15			
	GPIO23	16			
	GPIO24	17			
	GPIO25	—			
	GPIO0	—			
	GPIO1	18			
	GPIO2	—			
GPIO3	20				
GPIO4	21				
GPIO5	23				
GPIO6	26				
GPIO7	—				

**Table 6-4. RHB (QFN32) Peripheral Signal Descriptions (continued)**

FUNCTION	SIGNAL NAME	Pin No.	PIN TYPE	SIGNAL DIRECTION	DESCRIPTION
		QFN32			
I <sup>2</sup> C	I2C0_SCL	9	I/O	I/O	I <sup>2</sup> C clock data
		17			
		—			
		26			
	I2C0_SDA	2	I/O	I/O	I <sup>2</sup> C data
		4			
8					
—					
LRF Digital Output	LRFD3	—	I/O	O	LRF digital output 3
	LRFD0	3			LRF digital output 0
	LRFD5	20			LRF digital output 5
	LRFD1	7			LRF digital output 1
	LRFD7	13			LRF digital output 7
	LRFD6	21			LRF digital output 6
	LRFD2	18			LRF digital output 2
	LRFD4	23			LRF digital output 4
Power	VDDR	1	—	—	Internal supply
		27			
	VDDS	6	—	—	1.71V to 3.8V DIO supply
		14			
		25			
		30			
VDDD	22	—	—	For decoupling of internal 1.28V regulated core-supply.	
DCDC	24	—	—	Switching node of internal DC/DC converter	
Reset	RSTN	19	—	—	Global main device reset (active low)
RF	ANT	31	—	—	50 Ω RF port
RF Gound	RFGND	32	—	—	RF Ground reference

**Table 6-4. RHB (QFN32) Peripheral Signal Descriptions (continued)**

FUNCTION	SIGNAL NAME	Pin No.	PIN TYPE	SIGNAL DIRECTION	DESCRIPTION		
		QFN32					
SPI	SPI0SCLK	2	I/O	I/O	General SPI clock		
		9					
		10					
		17					
	SPI0POCI	3	I/O	I/O	SPI POCI		
		4					
		5					
		12					
		13					
	SPI0CSN	3	I/O	I/O	SPI chip select		
		—					
		26					
	SPI0PICO	4	I/O	I/O	SPI PICO		
		5					
		8					
		11					
21							
SWD	SWDIO	8	I/O	I/O	SWD IO		
	SWDCK	9	I/O	I	SWD Clock		
Timers - Capture/Compare	T0C0	3	I/O	I/O	Capture/compare Output-0 from Timer-0		
	T0C1	13			Capture/compare Output-1 from Timer-0		
	T0C2	9			Capture/compare Output-2 from Timer-0		
	T1C0	12	I/O	I/O	Capture/compare Output-0 from Timer-1		
		17					
	T1C1	4			Capture/compare Output-1 from Timer-1		
	T1C2	8			I/O	I/O	Capture/compare Output-2 from Timer-1
		20					
		26					
	T2C0	15	I/O	I/O	Capture/compare Output-0 from Timer-2		
	T2C1	16			Capture/compare Output-1 from Timer-2		
	T2C2	23			Capture/compare Output-2 from Timer-2		
	T3C0	—	I/O	I/O	Capture/compare Output-0 from Timer-3		
		10					
	T3C1	17			I/O	I/O	Capture/compare Output-1 from Timer-3
		11					
		18					
	T3C2	20			I/O	I/O	Capture/compare Output-2 from Timer-3
—							
7							
		—					

**Table 6-4. RHB (QFN32) Peripheral Signal Descriptions (continued)**

FUNCTION	SIGNAL NAME	Pin No.	PIN TYPE	SIGNAL DIRECTION	DESCRIPTION
		QFN32			
Timers - Complementary Capture/ Compare	T0C0N	2	I/O	O	Complementary compare/PWM Output-0 from Timer-0
		5			
		20			
	T0C1N	20			Complementary compare/PWM Output-1 from Timer-0
	T0C2N	21			Complementary compare/PWM Output-2 from Timer-0
	T1C0N	2	I/O	O	Complementary compare/PWM Output-0 from Timer-1
		8			
		9			
	T1C1N	13			Complementary compare/PWM Output-1 from Timer-1
	T1C2N	3			Complementary compare/PWM Output-2 from Timer-1
		7			
	T2C0N	—	I/O	O	Complementary compare/PWM Output-0 from Timer-2
	T2C1N	—			Complementary compare/PWM Output-1 from Timer-2
	T2C2N	—			Complementary compare/PWM Output-2 from Timer-2
	T3C0N	—	I/O	O	Complementary compare/PWM Output-0 from Timer-3
T3C1N	15	Complementary compare/PWM Output-1 from Timer-3			
T3C2N	16	Complementary compare/PWM Output-2 from Timer-3			
Timers - Fault input	T1F	5	I/O	I	Fault input for Timer-1
		7			
		18			
Timers - Prescaler Event	T2PE	—	I/O	O	Prescaler event output from Timer-2
		11			
	T0PE	17	I/O	O	Prescaler eveny output from Timer-0
UART	UART0TXD	5	I/O	O	UART0 TX data
		9			
		10			
		12			
		21			
		26			
	UART0RXD	4	I/O	I	UART0 RX data
		—			
		8			
		12			
	UART0CTS	13	I/O	I	UART0 clear-to-send input (active low)
		—			
	UART0RTS	2	I/O	O	UART0 request-to-send (active low)
		18			

## 7 Specifications

### 7.1 Absolute Maximum Ratings

over operating free-air temperature range (unless otherwise noted)<sup>(1) (2)</sup>

		MIN	MAX	UNIT
V <sub>DDS</sub>	Supply voltage	-0.3	4.1	V
	Voltage on any digital pin <sup>(3)</sup>	-0.3	V <sub>DDS</sub> + 0.3, max 4.1	V
	Voltage on crystal oscillator pins X48P and X48N	-0.3	1.24	V
V <sub>in_adc</sub>	Voltage on ADC input	0	V <sub>DDS</sub>	V
	Input level, RF pins		5	dBm
P <sub>max</sub>	Environmental Pressure		1400	kPa
A <sub>max</sub>	Static Acceleration		2000	g
T <sub>stg</sub>	Storage temperature	-40	150	°C

- Operation outside the Absolute Maximum Ratings may cause permanent device damage. Absolute Maximum Ratings do not imply functional operation of the device at these or any other conditions beyond those listed under Recommended Operating Conditions. If outside the Recommended Operating Conditions but within the Absolute Maximum Ratings, the device may not be fully functional, and this may affect device reliability, functionality, performance, and shorten the device lifetime.
- All voltage values are with respect to ground, unless otherwise noted.
- Including analog-capable DIOs

### 7.2 ESD Ratings

			VALUE	UNIT	
V <sub>ESD</sub>	Electrostatic discharge	Human body model (HBM), per AEC Q100-002 <sup>(1) (3) (4)</sup>	All pins except ANT pin	±2000	V
			ANT pin	±1000	V
		Charged device model (CDM), per AEC Q100-011 <sup>(2) (4)</sup>	All pins except ANT pin	±500	V
			ANT pin	±250	V

- JEDEC document JEP155 states that 500V HBM allows safe manufacturing with a standard ESD control process.
- JEDEC document JEP157 states that 250V CDM allows safe manufacturing with a standard ESD control process.
- AEC Q100-002 indicates HBM stressing is done in accordance with the ANSI/ESDA/JEDEC JS-001 specification.
- The ANT pin is an RF type pin, per the Absolute Maximum Ratings, and complies with the recommended ESD limits per JEP and AEC specifications listed above.

### 7.3 Recommended Operating Conditions

over operating free-air temperature range (unless otherwise noted)

		MIN	MAX	UNIT
CC2340xxxExxxxx devices (125°C parts)	Operating ambient temperature <sup>(1) (2)</sup>	-40	125	°C
	Operating junction temperature <sup>(1) (2)</sup>	-40	125	°C
Operating supply voltage (V <sub>DDS</sub> )		1.71	3.8	V
Rising supply voltage slew rate		0	100	mV/μs
Falling supply voltage slew rate <sup>(3)</sup>		0	1	mV/μs

- Operation at or near maximum operating temperature for extended durations will result in a reduction in lifetime.
- For thermal resistance details, refer to *Thermal Resistance Characteristics* table in this document.
- For small coin-cell batteries, with high worst-case end-of-life equivalent source resistance, a 10μF V<sub>DDS</sub> input capacitor must be used to ensure compliance with this slew rate.

### 7.4 DCDC

When measured on the CC2340R5 reference design with T<sub>c</sub> = 25°C and DCDC enabled unless otherwise noted.

PARAMETER	TEST CONDITIONS	MIN	TYP	MAX	UNIT
V <sub>DDS</sub> supply voltage for DCDC operation <sup>(1) (2)</sup>		2.2	3.0	3.8	V

- When the supply voltage drops below the DCDC operation min voltage, the device automatically transitions to use GLDO regulator on-chip.

(2) A 10 $\mu$ H and 10 $\mu$ F load capacitor are required on the VDDR voltage rail. They should be placed close to the DCDC output pin.

## 7.5 Global LDO (GLDO)

When measured on the CC2340R5 reference design with  $T_c = 25^\circ\text{C}$ .

PARAMETER	TEST CONDITIONS	MIN	TYP	MAX	UNIT
VDDS supply voltage for GLDO operation <sup>(1)</sup>		1.71	3.0	3.8	V

(1) A 10 $\mu$ F capacitor is recommended at the VDDR pin.

## 7.6 Power Supply and Modules

over operating free-air temperature range (unless otherwise noted)

PARAMETER	TEST CONDITIONS	MIN	TYP	MAX	UNIT
<b>VDDS_BOD</b>					
Brownout rising threshold <sup>(1)</sup>			1.68		V
Brownout falling threshold <sup>(1)</sup>			1.67		V
<b>POR</b>					
power-on reset power-up level			1.5		V
power-on reset power-down level			1.45		V

(1) The brown-out detector is trimmed at initial boot, value is kept until device is reset by a POR reset or the RSTN pin.

## 7.7 Battery Monitor

Measured on the CC2340R5 reference design with  $T_c = 25^\circ\text{C}$ , unless otherwise noted.

PARAMETER	TEST CONDITIONS	MIN	TYP	MAX	UNIT
Resolution			22		mV
Range		1.7		3.8	V
Accuracy	VDDS = 3.0V		30		mV

## 7.8 Temperature Sensor

Measured on the CC2340R5 reference design with  $T_c = 25^\circ\text{C}$ ,  $V_{\text{DDS}} = 3.0\text{V}$ , unless otherwise noted.

PARAMETER	TEST CONDITIONS	MIN	TYP	MAX	UNIT
Accuracy	$-40^\circ\text{C}$ to $125^\circ\text{C}$		$-15/+9^{(1)}$		$^\circ\text{C}$

(1) Raw output from PMUD register

## 7.9 Power Consumption—Power Modes

When measured on the CC2340R5 reference design with  $T_c = 25^\circ\text{C}$ ,  $V_{\text{DD5}} = 3.0\text{V}$ , DCDC enabled, GLDO disabled, unless otherwise noted.

PARAMETER	TEST CONDITIONS		MIN	TYP	MAX	UNIT
<b>Core Current Consumption with DCDC</b>						
$I_{\text{core}}$	Active	MCU running CoreMark from Flash at 48MHz		2.6		mA
$I_{\text{core}}$	Active	MCU running CoreMark from Flash at 48MHz		53		$\mu\text{A} / \text{MHz}$
$I_{\text{core}}$	Idle	Supply Systems and RAM powered, flash disabled, DMA disabled		0.8		mA
$I_{\text{core}}$	Idle	Supply Systems and RAM powered, flash disabled, DMA enabled		0.8		mA
$I_{\text{core}}$	Idle	Supply Systems and RAM powered, flash enabled, DMA disabled		1.1		mA
$I_{\text{core}}$	Idle	Supply Systems and RAM powered, flash enabled, DMA enabled		1.2		mA
$I_{\text{core}}$	Standby	RTC running, full RAM retention LFOSC, DCDC recharge current setting (ipeak = 1)		0.71		$\mu\text{A}$
$I_{\text{core}}$	Standby	RTC running, full RAM retention LFXT, DCDC recharge current setting (ipeak = 1)		0.74		$\mu\text{A}$
<b>Core Current consumption with GLDO</b>						
$I_{\text{core}}$	Active	MCU running CoreMark from Flash at 48MHz		4.1		mA
$I_{\text{core}}$	Idle	Supply Systems and RAM powered, flash disabled, DMA disabled		1.2		mA
$I_{\text{core}}$	Idle	Supply Systems and RAM powered, flash disabled, DMA enabled		1.3		mA
$I_{\text{core}}$	Idle	Supply Systems and RAM powered, flash enabled, DMA disabled		1.5		mA
$I_{\text{core}}$	Idle	Supply Systems and RAM powered, flash enabled, DMA enabled		1.7		mA
$I_{\text{core}}$	Standby	RTC running, full RAM retention LFOSC, default GLDO recharge current setting		1.1		$\mu\text{A}$
$I_{\text{core}}$	Standby	RTC running, full RAM retention LFXT default GLDO recharge current setting		1.15		$\mu\text{A}$
<b>Reset, Shutdown Current Consumption</b>						
$I_{\text{core}}$	Reset	Reset. RSTN pin asserted or VDD5 below power-on-reset threshold		165		nA
$I_{\text{core}}$	Shutdown	Shutdown measured in steady state. No clocks running, no retention, IO wakeup enabled		165		nA
<b>Peripheral Current Consumption</b>						
$I_{\text{peri}}$	RF	Delta current, clock enabled, RF subsystem idle		40		$\mu\text{A}$
$I_{\text{peri}}$	Timers	Delta current with clock enabled, module is idle, one LGPT timer		2.4		$\mu\text{A}$
$I_{\text{peri}}$	I2C	Delta current with clock enabled, module is idle		10.6		$\mu\text{A}$
$I_{\text{peri}}$	SPI	Delta current with clock enabled, module is idle		3.4		$\mu\text{A}$
$I_{\text{peri}}$	UART	Delta current with clock enabled, module is idle		24.5		$\mu\text{A}$
$I_{\text{peri}}$	CRYPTO (AES)	Delta current with clock enabled, module is idle		3.8		$\mu\text{A}$

## 7.10 Power Consumption—Radio Modes

When measured on the CC2340R5 reference design with  $T_c = 25^\circ\text{C}$ ,  $V_{\text{DDS}} = 3.0\text{V}$  with DCDC enabled unless otherwise noted.

PARAMETER		TEST CONDITIONS	MIN	TYP	MAX	UNIT
$I_{\text{RX}}$	Radio receive current	2440MHz, 1Mbps, GFSK, system bus off <sup>(1)</sup>		5.3		mA
$I_{\text{RX}}$	Radio receive current	2440MHz, 1Mbps, GFSK, DCDC OFF, system bus off <sup>(1)</sup>		9		mA
$I_{\text{TX}}$	Radio transmit current	-8dBm output power setting 2440MHz system bus off <sup>(1)</sup>		4.5		mA
$I_{\text{TX}}$	Radio transmit current	0dBm output power setting 2440MHz system bus off <sup>(1)</sup>		5.1		mA
$I_{\text{TX}}$	Radio transmit current	0dBm output power setting 2440MHz DCDC OFF, system bus off <sup>(1)</sup>		9.0		mA
$I_{\text{TX}}$	Radio transmit current	+4dBm output power setting 2440MHz system bus off <sup>(1)</sup>		7.9		mA
$I_{\text{TX}}$	Radio transmit current	+6dBm output power setting 2440MHz system bus off <sup>(1)</sup>		8.9		mA
$I_{\text{TX}}$	Radio transmit current	+8dBm output power setting 2440MHz system bus off <sup>(1)</sup>		10.7		mA
$I_{\text{TX}}$	Radio transmit current	+8dBm output power setting 2440MHz DCDC OFF, system bus off <sup>(1)</sup>		19		mA

(1) System bus off refers to device idle mode, DMA disabled, flash disabled

## 7.11 Nonvolatile (Flash) Memory Characteristics

Over operating free-air temperature range and  $V_{\text{DDS}} = 3.0\text{V}$  (unless otherwise noted)

PARAMETER	TEST CONDITIONS	MIN	TYP	MAX	UNIT
Flash sector size			2		KB
Supported flash erase cycles before failure, full bank <sup>(1) (2)</sup>		30			k Cycles
Supported flash erase cycles before failure, single sector <sup>(3)</sup>		60			k Cycles
Maximum number of write operations per row before sector erase <sup>(4)</sup>				83	Write Operations
Flash retention	105 °C	11.4			Years
Flash retention	125°C	10			Years
Flash sector erase current	Average delta current		1.2		mA
Flash sector erase time <sup>(5)</sup>	0 erase cycles		2.2		ms
Flash write current	Average delta current, full sector at a time		1.7		mA
Flash write time <sup>(5)</sup>	full sector (2kB) at a time, 0 erase cycles		8.3		ms

- (1) A full bank erase is counted as a single erase cycle on each sector
- (2) Aborting flash during erase or program modes is not a safe operation.
- (3) Up to 16 customer-designated sectors can be individually erased an additional 30k times beyond the baseline bank limitation of 30k cycles
- (4) Each wordline is 2048 bits (or 256 bytes) wide. This limitation corresponds to sequential memory writes of 4 (3.1) bytes minimum per write over a whole wordline. If additional writes to the same wordline are required, a sector erase is required once the maximum number of write operations per row is reached.
- (5) This number is dependent on Flash aging and increases over time and erase cycles

## 7.12 Thermal Resistance Characteristics

THERMAL METRIC	THERMAL METRIC	PACKAGE	UNIT
		RHB (VQFN)	
		32 PINS	
$R_{\theta\text{JA}}$	Junction-to-ambient thermal resistance	32.6	$^\circ\text{C/W}$ <sup>(1)</sup>
$R_{\theta\text{JC(top)}}$	Junction-to-case (top) thermal resistance	22.8	$^\circ\text{C/W}$ <sup>(1)</sup>
$R_{\theta\text{JB}}$	Junction-to-board thermal resistance	12.7	$^\circ\text{C/W}$ <sup>(1)</sup>
$\Psi_{\text{JT}}$	Junction-to-top characterization parameter	0.3	$^\circ\text{C/W}$ <sup>(1)</sup>

## 7.12 Thermal Resistance Characteristics (continued)

THERMAL METRIC	THERMAL METRIC	PACKAGE		UNIT
		RHB (VQFN)		
		32 PINS		
$\Psi_{JB}$	Junction-to-board characterization parameter	12.6		$^{\circ}\text{C}/\text{W}$ <sup>(1)</sup>
$R_{\theta JC(\text{bot})}$	Junction-to-case (bottom) thermal resistance	3.3		$^{\circ}\text{C}/\text{W}$ <sup>(1)</sup>

(1)  $^{\circ}\text{C}/\text{W}$  = degrees Celsius per watt.

## 7.13 Thermal Shutdown

over operating free-air temperature range (unless otherwise noted)

PARAMETER		TEST CONDITIONS	MIN	TYP	MAX	UNIT
$V_{OP}$	Operating supply voltage		1.71		3.8	V
$T_{Jun}$	Operating junction temperature		96		150	$^{\circ}\text{C}$
$T_{rstrel}$	Reset release temperature		101.8		114	$^{\circ}\text{C}$
$I_{core\_TSD}$	Current consumption in thermal shutdown mode (up to 150C)				100	$\mu\text{A}$

## 7.14 RF Frequency Bands

Over operating free-air temperature range (unless otherwise noted).

PARAMETER	MIN	TYP	MAX	UNIT
Frequency bands	2360		2510	MHz

## 7.15 Bluetooth Low Energy—Receive (RX)

When measured on the CC2340R5 reference design with  $T_c = 25^{\circ}\text{C}$ ,  $V_{DD5} = 3.0\text{V}$ ,  $f_{RF} = 2440\text{MHz}$  with DCDC enabled unless otherwise noted. All measurements are performed at the antenna input with a combined RX and TX path. All measurements are performed conducted.

PARAMETER	TEST CONDITIONS	MIN	TYP	MAX	UNIT
<b>125kbps (LE Coded)</b>					
Receiver sensitivity	$\text{BER} = 10^{-3}$		-102		dBm
Receiver saturation	$\text{BER} = 10^{-3}$		5		dBm
Frequency error tolerance	Difference between the incoming carrier frequency and the internally generated carrier frequency		> (-250 / 250) <sup>(1)</sup>		kHz
Data rate error tolerance	Difference between incoming data rate and the internally generated data rate (37-byte packets)		> (-90 / 90) <sup>(1)</sup>		ppm
Data rate error tolerance	Difference between incoming data rate and the internally generated data rate (255-byte packets)		> (-90 / 90) <sup>(1)</sup>		ppm
Co-channel rejection <sup>(2)</sup>	Wanted signal at -79dBm, modulated interferer in channel, $\text{BER} = 10^{-3}$		-6		dB
Selectivity, $\pm 1\text{MHz}$ <sup>(2)</sup>	Wanted signal at -79dBm, modulated interferer at $\pm 1\text{MHz}$ , $\text{BER} = 10^{-3}$		9 / 5 <sup>(3)</sup>		dB
Selectivity, $\pm 2\text{MHz}$ <sup>(2)</sup>	Wanted signal at -79dBm, modulated interferer at $\pm 2\text{MHz}$ , $\text{BER} = 10^{-3}$		44 / 31 <sup>(3)</sup>		dB
Selectivity, $\pm 3\text{MHz}$ <sup>(2)</sup>	Wanted signal at -79dBm, modulated interferer at $\pm 3\text{MHz}$ , $\text{BER} = 10^{-3}$		47 / 42 <sup>(3)</sup>		dB
Selectivity, $\pm 4\text{MHz}$ <sup>(2)</sup>	Wanted signal at -79dBm, modulated interferer at $\pm 4\text{MHz}$ , $\text{BER} = 10^{-3}$		49 / 45 <sup>(3)</sup>		dB
Selectivity, $\pm 6\text{MHz}$ <sup>(2)</sup>	Wanted signal at -79dBm, modulated interferer at $\geq \pm 6\text{MHz}$ , $\text{BER} = 10^{-3}$		52 / 48 <sup>(3)</sup>		dB
Selectivity, $\pm 7\text{MHz}$	Wanted signal at -79dBm, modulated interferer at $\geq \pm 7\text{MHz}$ , $\text{BER} = 10^{-3}$		54 / 49 <sup>(3)</sup>		dB
Selectivity, Image frequency <sup>(2)</sup>	Wanted signal at -79dBm, modulated interferer at image frequency, $\text{BER} = 10^{-3}$		31		dB

## 7.15 Bluetooth Low Energy—Receive (RX) (continued)

When measured on the CC2340R5 reference design with  $T_c = 25^\circ\text{C}$ ,  $V_{\text{DDS}} = 3.0\text{V}$ ,  $f_{\text{RF}} = 2440\text{MHz}$  with DCDC enabled unless otherwise noted. All measurements are performed at the antenna input with a combined RX and TX path. All measurements are performed conducted.

PARAMETER	TEST CONDITIONS	MIN	TYP	MAX	UNIT
Selectivity, Image frequency $\pm 1\text{MHz}^{(2)}$	Note that Image frequency + 1MHz is the Co- channel –1MHz. Wanted signal at –79dBm, modulated interferer at $\pm 1\text{MHz}$ from image frequency, BER = $10^{-3}$		5 / 42 <sup>(3)</sup>		dB
<b>500kbps (LE Coded)</b>					
Receiver sensitivity	BER = $10^{-3}$		–99		dBm
Receiver saturation	BER = $10^{-3}$		5		dBm
Frequency error tolerance	Difference between the incoming carrier frequency and the internally generated carrier frequency		> (–250 / 250) <sup>(1)</sup>		kHz
Data rate error tolerance	Difference between incoming data rate and the internally generated data rate (37-byte packets)		> (–90 / 90) <sup>(1)</sup>		ppm
Data rate error tolerance	Difference between incoming data rate and the internally generated data rate (255-byte packets)		> (–90 / 90) <sup>(1)</sup>		ppm
Co-channel rejection <sup>(2)</sup>	Wanted signal at –72dBm, modulated interferer in channel, BER = $10^{-3}$		–4.5		dB
Selectivity, $\pm 1\text{MHz}^{(2)}$	Wanted signal at –72dBm, modulated interferer at $\pm 1\text{MHz}$ , BER = $10^{-3}$		9 / 5 <sup>(3)</sup>		dB
Selectivity, $\pm 2\text{MHz}^{(2)}$	Wanted signal at –72dBm, modulated interferer at $\pm 2\text{MHz}$ , BER = $10^{-3}$		42 / 31 <sup>(3)</sup>		dB
Selectivity, $\pm 3\text{MHz}^{(2)}$	Wanted signal at –72dBm, modulated interferer at $\pm 3\text{MHz}$ , BER = $10^{-3}$		45 / 41 <sup>(3)</sup>		dB
Selectivity, $\pm 4\text{MHz}^{(2)}$	Wanted signal at –72dBm, modulated interferer at $\pm 4\text{MHz}$ , BER = $10^{-3}$		46 / 42 <sup>(3)</sup>		dB
Selectivity, $\pm 6\text{MHz}^{(2)}$	Wanted signal at –72dBm, modulated interferer at $\geq \pm 6\text{MHz}$ , BER = $10^{-3}$		50 / 45 <sup>(3)</sup>		dB
Selectivity, $\pm 7\text{MHz}$	Wanted signal at –72dBm, modulated interferer at $\geq \pm 7\text{MHz}$ , BER = $10^{-3}$		51 / 46 <sup>(3)</sup>		dB
Selectivity, Image frequency <sup>(2)</sup>	Wanted signal at –72dBm, modulated interferer at image frequency, BER = $10^{-3}$		31		dB
Selectivity, Image frequency $\pm 1\text{MHz}^{(2)}$	Note that Image frequency + 1MHz is the Co- channel –1MHz. Wanted signal at –72dBm, modulated interferer at $\pm 1\text{MHz}$ from image frequency, BER = $10^{-3}$		5 / 41 <sup>(3)</sup>		dB
<b>1Mbps (LE 1M)</b>					
Receiver sensitivity	BER = $10^{-3}$		–96.5		dBm
Receiver saturation	BER = $10^{-3}$		5		dBm
Frequency error tolerance	Difference between the incoming carrier frequency and the internally generated carrier frequency		> (–250/250) <sup>(1)</sup>		kHz
Data rate error tolerance	Difference between incoming data rate and the internally generated data rate (37-byte packets)		> (–90 / 90) <sup>(1)</sup>		ppm
Co-channel rejection <sup>(2)</sup>	Wanted signal at –67dBm, modulated interferer in channel, BER = $10^{-3}$		–6		dB
Selectivity, $\pm 1\text{MHz}^{(2)}$	Wanted signal at –67dBm, modulated interferer at $\pm 1\text{MHz}$ , BER = $10^{-3}$		7 / 5 <sup>(3)</sup>		dB
Selectivity, $\pm 2\text{MHz}^{(2)}$	Wanted signal at –67dBm, modulated interferer at $\pm 2\text{MHz}$ , BER = $10^{-3}$		39 / 28 <sup>(3)</sup>		dB
Selectivity, $\pm 3\text{MHz}^{(2)}$	Wanted signal at –67dBm, modulated interferer at $\pm 3\text{MHz}$ , BER = $10^{-3}$		38 / 38 <sup>(3)</sup>		dB
Selectivity, $\pm 4\text{MHz}^{(2)}$	Wanted signal at –67dBm, modulated interferer at $\pm 4\text{MHz}$ , BER = $10^{-3}$		47 / 35 <sup>(3)</sup>		dB
Selectivity, $\pm 5\text{MHz}$ or more <sup>(2)</sup>	Wanted signal at –67dBm, modulated interferer at $\geq \pm 5\text{MHz}$ , BER = $10^{-3}$		40		dB
Selectivity, image frequency <sup>(2)</sup>	Wanted signal at –67dBm, modulated interferer at image frequency, BER = $10^{-3}$		28		dB
Selectivity, image frequency $\pm 1\text{MHz}^{(2)}$	Note that Image frequency + 1MHz is the Co- channel –1MHz. Wanted signal at –67dBm, modulated interferer at $\pm 1\text{MHz}$ from image frequency, BER = $10^{-3}$		5 / 38 <sup>(3)</sup>		dB

## 7.15 Bluetooth Low Energy—Receive (RX) (continued)

When measured on the CC2340R5 reference design with  $T_c = 25^\circ\text{C}$ ,  $V_{\text{DDS}} = 3.0\text{V}$ ,  $f_{\text{RF}} = 2440\text{MHz}$  with DCDC enabled unless otherwise noted. All measurements are performed at the antenna input with a combined RX and TX path. All measurements are performed conducted.

PARAMETER	TEST CONDITIONS	MIN	TYP	MAX	UNIT
Out-of-band blocking <sup>(4)</sup>	30MHz to 2000MHz		-10		dBm
Out-of-band blocking	2003MHz to 2399MHz		-10		dBm
Out-of-band blocking	2484MHz to 2997MHz		-10		dBm
Out-of-band blocking	3000MHz to 12.75 GHz (excluding VCO frequency)		-2		dBm
Intermodulation	Wanted signal at 2402MHz, -64dBm. Two interferers at 2405 and 2408MHz respectively, at the given power level		-37		dBm
Spurious emissions, 30 to 1000MHz <sup>(5)</sup>	Measurement in a 50Ω single-ended load.		< -59		dBm
Spurious emissions, 1 to 12.75 GHz <sup>(5)</sup>	Measurement in a 50Ω single-ended load.		< -47		dBm
RSSI dynamic range <sup>(6)</sup>			70		dB
RSSI accuracy			±4		dB
RSSI resolution			1		dB
<b>2Mbps (LE 2M)</b>					
Receiver sensitivity	Measured at SMA connector, BER = $10^{-3}$		-92		dBm
Receiver saturation	Measured at SMA connector, BER = $10^{-3}$		2		dBm
Frequency error tolerance	Difference between the incoming carrier frequency and the internally generated carrier frequency		> (-250 / 250) <sup>(1)</sup>		kHz
Data rate error tolerance	Difference between incoming data rate and the internally generated data rate (37-byte packets)		> (-90/ 90) <sup>(1)</sup>		ppm
Co-channel rejection <sup>(2)</sup>	Wanted signal at -67dBm, modulated interferer in channel, BER = $10^{-3}$		-8		dB
Selectivity, ±2MHz <sup>(2)</sup>	Wanted signal at -67dBm, modulated interferer at ±2MHz, Image frequency is at -2MHz, BER = $10^{-3}$		9 / 5 <sup>(3)</sup>		dB
Selectivity, ±4MHz <sup>(2)</sup>	Wanted signal at -67dBm, modulated interferer at ±4MHz, BER = $10^{-3}$		40 / 32 <sup>(3)</sup>		dB
Selectivity, ±6MHz <sup>(2)</sup>	Wanted signal at -67dBm, modulated interferer at ±6MHz, BER = $10^{-3}$		46 / 40 <sup>(3)</sup>		dB
Selectivity, image frequency <sup>(2)</sup>	Wanted signal at -67dBm, modulated interferer at image frequency, BER = $10^{-3}$		5		dB
Selectivity, image frequency ±2MHz <sup>(2)</sup>	Note that Image frequency + 2MHz is the Co-channel. Wanted signal at -67dBm, modulated interferer at ±2MHz from image frequency, BER = $10^{-3}$		-8 / 32 <sup>(3)</sup>		dB
Out-of-band blocking <sup>(4)</sup>	30MHz to 2000MHz		-10		dBm
Out-of-band blocking	2003MHz to 2399MHz		-10		dBm
Out-of-band blocking	2484MHz to 2997MHz		-12		dBm
Out-of-band blocking	3000MHz to 12.75 GHz (excluding VCO frequency)		-10		dBm
Intermodulation	Wanted signal at 2402MHz, -64dBm. Two interferers at 2408 and 2414MHz respectively, at the given power level		-38		dBm

(1) Actual performance exceeding Bluetooth specification

(2) Numbers given as I/CdB

(3) X / Y, where X is +NMHz and Y is -NMHz

(4) Excluding one exception at  $F_{\text{wanted}} / 2$ , per Bluetooth Specification

(5) Suitable for systems targeting compliance with worldwide radio-frequency regulations ETSI EN 300 328 and EN 300 440 Class 2 (Europe), FCC CFR47 Part 15 (US), and ARIB STD-T66 (Japan)

(6) The RSSI measurement will saturate at -30dBm

## 7.16 Bluetooth Low Energy—Transmit (TX)

When measured on the CC2340R5 reference design with  $T_c = 25^\circ\text{C}$ ,  $V_{\text{DDS}} = 3.0\text{V}$ ,  $f_{\text{RF}} = 2440\text{MHz}$  with DCDC enabled unless otherwise noted. All measurements are performed at the antenna input with a combined RX and TX path. All measurements are performed conducted.

PARAMETER	TEST CONDITIONS	MIN	TYP	MAX	UNIT
<b>General Parameters</b>					
Max output power	Delivered to a single-ended 50Ω load through integrated balun		8		dBm
Output power programmable range	Delivered to a single-ended 50Ω load through integrated balun		28		dB

## 7.17 2.4GHz RX/TX CW

When measured on the CC2340R5 reference design with  $T_c = 25^\circ\text{C}$ ,  $V_{\text{DDS}} = 3.0\text{V}$ ,  $f_{\text{RF}} = 2440\text{MHz}$  with DCDC enabled unless otherwise noted. All measurements are performed at the antenna input with a combined RX and TX path. All measurements are performed conducted.

PARAMETER	TEST CONDITIONS	MIN	TYP	MAX	UNIT
<b>Spurious emissions and harmonics</b>					
Spurious emissions <sup>(1)</sup>	f < 1 GHz, outside restricted bands		< -36		dBm
	f < 1 GHz, restricted bands ETSI		< -54		dBm
	f < 1 GHz, restricted bands FCC		< -55		dBm
	f > 1 GHz, including harmonics (ETSI)	+8dBm setting	< -30		dBm
Harmonics <sup>(1)</sup>	Second harmonic		< -42		dBm
	Third harmonic		< -42		dBm

(1) Suitable for systems targeting compliance with worldwide radio-frequency regulations ETSI EN 300 328 and EN 300 440 Class 2 (Europe), FCC CFR47 Part 15 (US), and ARIB STD-T66 (Japan).

## 7.18 Timing and Switching Characteristics

### 7.18.1 Reset Timing

PARAMETER	MIN	TYP	MAX	UNIT
RSTN low duration	1			μs

### 7.18.2 Wakeup Timing

Measured over operating free-air temperature with  $V_{\text{DDS}} = 3.0\text{V}$  (unless otherwise noted). The times listed here do not include any software overhead (unless otherwise noted).

PARAMETER	TEST CONDITIONS	MIN	TYP	MAX	UNIT
MCU, Reset/Shutdown to Active <sup>(1)</sup>	GLDO default charge current setting, VDDR capacitor fully charged <sup>(2)</sup>		350-450		μs
MCU, Standby to Active	MCU, Standby to Active (ready to execute code from flash). DCDC ON, default recharge current configuration		33-43 <sup>(3)</sup>		μs
MCU, Standby to Active	MCU, Standby to Active (ready to execute code from flash). GLDO ON, default recharge current configuration		33-50 <sup>(3)</sup>		μs
MCU, Idle to Active	Flash enabled in idle mode		3		μs
MCU, Idle to Active	Flash disabled in idle mode		14		μs

- (1) Wakeup time includes device ROM bootcode execution time. The wakeup time is dependent on remaining charge on VDDR capacitor when starting the device, and thus how long the device has been in Reset or Shutdown before starting up again.
- (2) This is the best case reset/shutdown to active time (including ROM bootcode operation), for the specified GLDO charge current setting considering the VDDR capacitor is fully charged and is not discharged during the reset and shutdown events; that is, when the device is in reset / shutdown modes for only a very short period of time
- (3) Depending on VDDR capacitor voltage level.

### 7.18.3 Clock Specifications

#### 7.18.3.1 48MHz Crystal Oscillator (HFXT)

Measured on the CC2340R5 reference design with  $T_c = 25^\circ\text{C}$ ,  $V_{\text{DDS}} = 3.0\text{V}$ , unless otherwise noted.<sup>(4)</sup>

	PARAMETER	MIN	TYP	MAX	UNIT
	Crystal frequency		48		MHz
ESR	Equivalent series resistance <sup>(5) (6)</sup> $C_L = 9\text{pF}$			35	$\Omega$
	Equivalent series resistance <sup>(5) (6)</sup> $C_L = 8\text{pF}$			50	$\Omega$
	Equivalent series resistance <sup>(5) (6)</sup> $C_L = 7\text{pF}$			60	$\Omega$
	Equivalent series resistance <sup>(5) (6)</sup> $5\text{pF} \leq C_L \leq 6\text{pF}$			80	$\Omega$
$C_L$	Crystal load capacitance <sup>(1)</sup>	5	7 <sup>(2)</sup>	9	pF
Start-up time <sup>(3)</sup>	Until clock is qualified		200		$\mu\text{s}$

- (1) Adjustable load capacitance is integrated into the device. External load capacitors are required for systems targeting compliance with certain regulations.
- (2) On-chip default connected capacitance including reference design parasitic capacitance. Connected internal capacitance is changed through software in the SysConfig.
- (3) Start-up time using the TI-provided power driver. Start-up time may increase if driver is not used.
- (4) Tai-Saw TZ3908AAAO43 has been validated for CC2340R5 design.
- (5) The max ESR value will be reduced if the crystal has a shunt capacitance of  $C_0 > 1\text{pF}$
- (6) Startup margin  $\geq 10$

#### 7.18.3.2 48MHz RC Oscillator (HFOSC)

Measured on the CC2340R5 reference design with  $T_c = 25^\circ\text{C}$ ,  $V_{\text{DDS}} = 3.0\text{V}$ , unless otherwise noted.

	MIN	TYP	MAX	UNIT
Frequency		48		MHz
Uncalibrated frequency accuracy		$\pm 3$		%
Calibrated frequency accuracy <sup>(1)</sup>		$\pm 0.25$		%

- (1) Accuracy relative to the calibration source (HFXT)

#### 7.18.3.3 32kHz Crystal Oscillator (LFXT)

Measured on the CC2340R5 reference design with  $T_c = 25^\circ\text{C}$ ,  $V_{\text{DDS}} = 3.0\text{V}$ , unless otherwise noted.

	MIN	TYP	MAX	UNIT
Crystal frequency		32.768		kHz
Supported crystal load capacitance	6		12	pF
ESR		30	100	k $\Omega$

#### 7.18.3.4 32kHz RC Oscillator (LFOSC)

Measured on the CC2340R5 reference design with  $T_c = 25^\circ\text{C}$ ,  $V_{\text{DDS}} = 3.0\text{V}$ , unless otherwise noted.

	MIN	TYP	MAX	UNIT
Calibrated frequency		32.768		kHz

## 7.19 Peripheral Characteristics

### 7.19.1 UART

#### 7.19.1.1 UART Characteristics

over operating free-air temperature range (unless otherwise noted)

PARAMETER	MIN	TYP	MAX	UNIT
UART rate			3	MBaud

### 7.19.2 SPI

#### 7.19.2.1 SPI Characteristics

Using TI SPI driver, over operating free-air temperature range (unless otherwise noted).

PARAMETERS		TEST CONDITIONS	MIN	TYP	MAX	UNIT
fSCLK 1/tsclk	SPI clock frequency	Controller Mode and Peripheral Mode <sup>(1)</sup> 2.7V ≤ VDD5 < 3.8V			12	MHz
		Controller Mode and Peripheral Mode <sup>(1)</sup> VDD5 < 2.7V			8	MHz
DC <sub>SCK</sub>	SCK Duty Cycle		45	50	55	%

(1) Assume interfacing with ideal SPI controller and SPI peripheral devices

#### 7.19.2.2 SPI Controller Mode

Using TI SPI driver, over operating free-air temperature range (unless otherwise noted)

PARAMETERS		TEST CONDITIONS	MIN	TYP	MAX	UNIT
t <sub>SCLK_H/L</sub>	SCLK High or Low time		(t <sub>SP/2</sub> ) - 1	t <sub>SP/2</sub>	(t <sub>SP/2</sub> ) + 1	ns
t <sub>CS.LEAD</sub>	CS lead-time, CS active to clock		1/2			SCLK
t <sub>CS.LAG</sub>	CS lag time, Last clock to CS inactive		1/2			SCLK
t <sub>CS.ACC</sub>	CS access time, CS active to PICO data out				1	SCLK
t <sub>CS.DIS</sub>	CS disable time, CS inactive to PICO high impedance				1	SCLK
t <sub>VALID.CO</sub>	PICO output data valid time <sup>(1)</sup>	SCLK edge to PICO valid, C <sub>L</sub> = 20pF			13	ns
t <sub>HD.CO</sub>	PICO output data hold time <sup>(2)</sup>	C <sub>L</sub> = 20pF	0			ns

(1) Specifies the time to drive the next valid data to the output after the output changing SCLK clock edge

(2) Specifies how long data on the output is valid after the output changing SCLK clock edge

### 7.19.2.3 SPI Timing Diagrams—Controller Mode

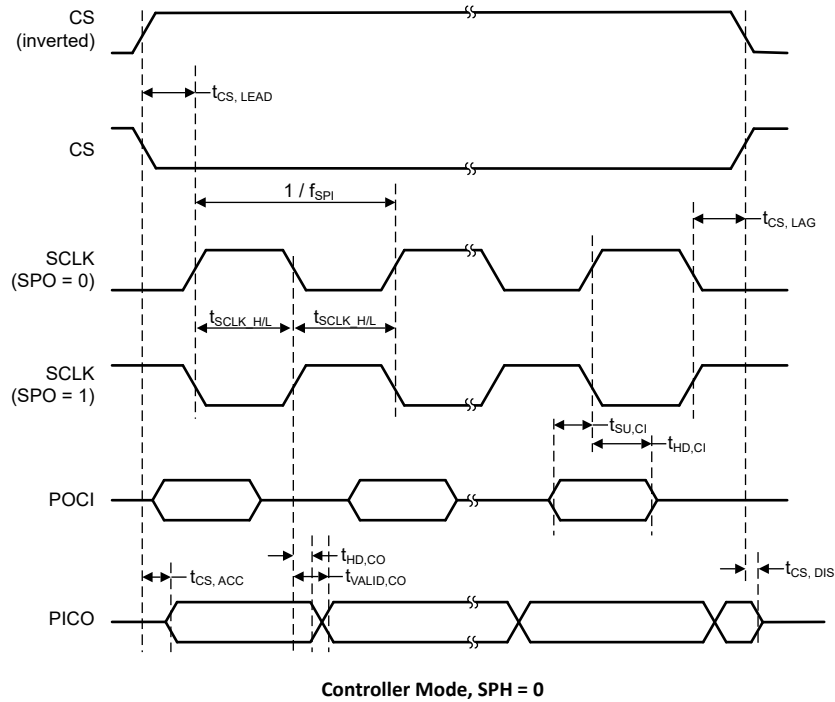


Figure 7-1. SPI Timing Diagram—Controller Mode, SPH = 0

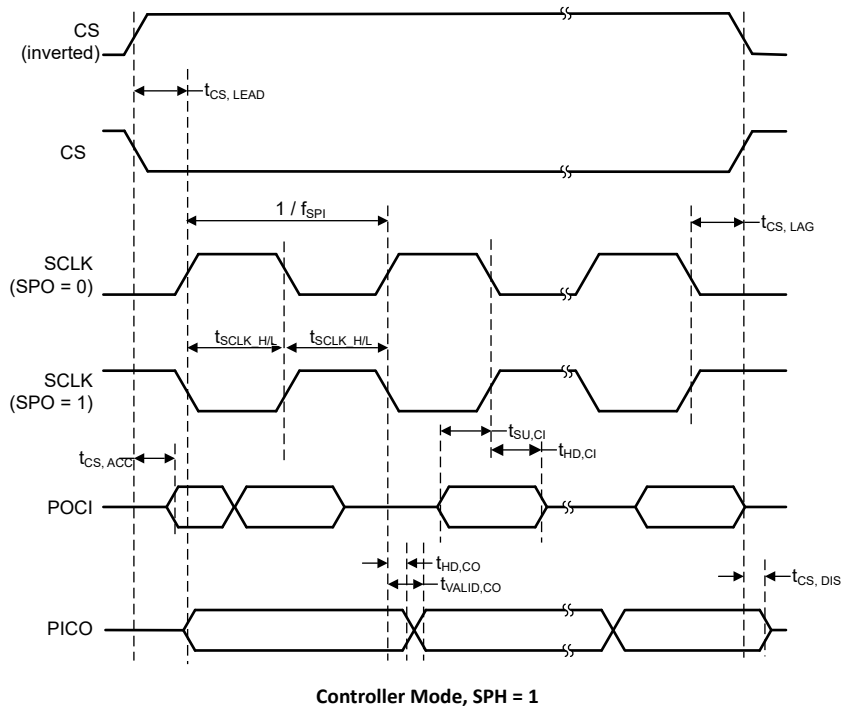


Figure 7-2. SPI Timing Diagram—Controller Mode, SPH = 1

### 7.19.2.4 SPI Peripheral Mode

Using TI SPI driver, over operating free-air temperature range (unless otherwise noted),

PARAMETERS		TEST CONDITIONS	MIN	TYP	MAX	UNIT
$t_{CS, LEAD}$	CS lead-time, CS active to clock		1/2			SCLK

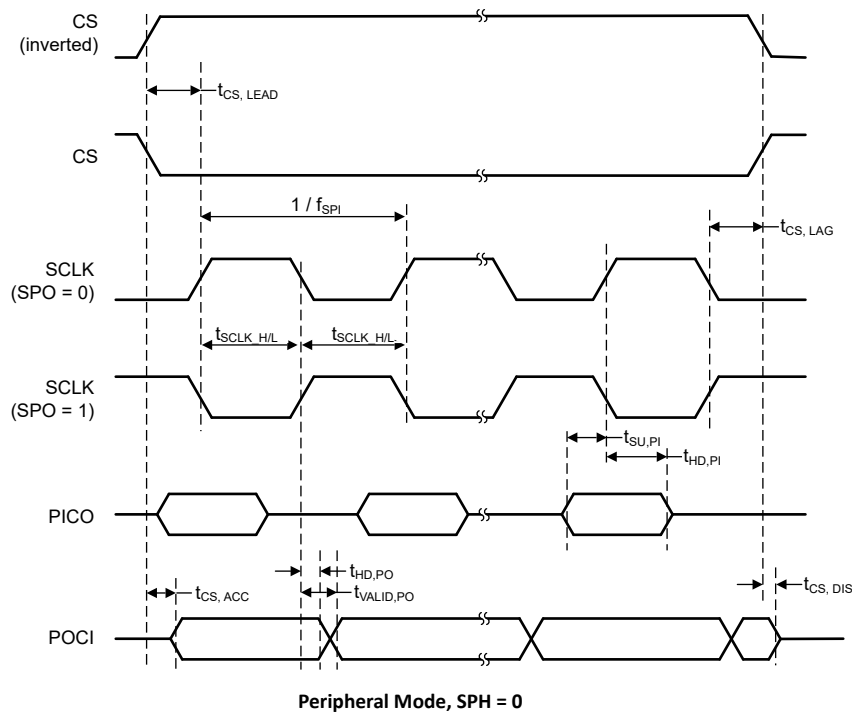
**7.19.2.4 SPI Peripheral Mode (continued)**

Using TI SPI driver, over operating free-air temperature range (unless otherwise noted),

PARAMETERS		TEST CONDITIONS	MIN	TYP	MAX	UNIT
t <sub>CS,LAG</sub>	CS lag time, Last clock to CS inactive		1/2			SCLK
t <sub>CS,ACC</sub>	CS access time, CS active to POCI data out	V <sub>DD5</sub> = 3.3V			35	ns
t <sub>CS,ACC</sub>	CS access time, CS active to POCI data out	V <sub>DD5</sub> = 1.8V			50	ns
t <sub>CS,DIS</sub>	CS disable time, CS inactive to POCI high impedance	V <sub>DD5</sub> = 3.3V			35	ns
t <sub>CS,DIS</sub>	CS disable time, CS inactive to POCI high impedance	V <sub>DD5</sub> = 1.8V			50	ns
t <sub>SU,PI</sub>	PICO input data setup time		13			ns
t <sub>HD,PI</sub>	PICO input data hold time		0			ns
t <sub>VALID,PO</sub>	POCI output data valid time <sup>(1)</sup>	SCLK edge to POCI valid, C <sub>L</sub> = 20pF, 3.3V			35	ns
t <sub>VALID,PO</sub>	POCI output data valid time <sup>(1)</sup>	SCLK edge to POCI valid, C <sub>L</sub> = 20pF, 1.8V			50	ns
t <sub>HD,PO</sub>	POCI output data hold time <sup>(2)</sup>	C <sub>L</sub> = 20pF	0			ns

- (1) Specifies the time to drive the next valid data to the output after the output changing SCLK clock edge
- (2) Specifies how long data on the output is valid after the output changing SCLK clock edge

**7.19.2.5 SPI Timing Diagrams—Peripheral Mode**



**Figure 7-3. SPI Timing Diagram—Peripheral Mode, SPH = 0**

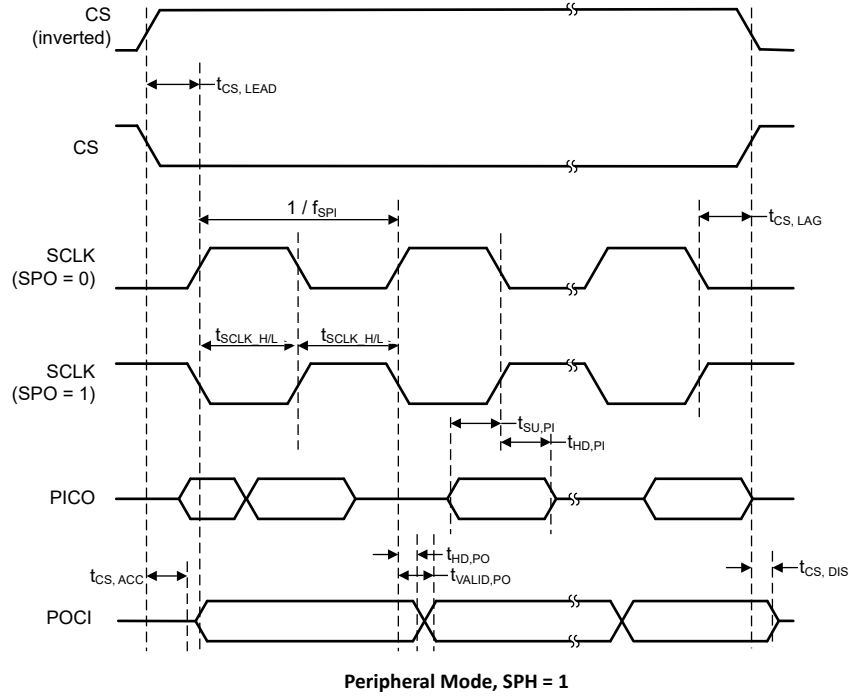


Figure 7-4. SPI Timing Diagram—Peripheral Mode, SPH = 1

### 7.19.3 I<sup>2</sup>C

#### 7.19.3.1 I2C

Over operating free-air temperature range (unless otherwise noted)

PARAMETERS		TEST CONDITIONS	MIN	TYP	MAX	UNIT
f <sub>SCL</sub>	SCL clock frequency		0	400		kHz
t <sub>HD,STA</sub>	Hold time (repeated) START	f <sub>SCL</sub> = 100kHz	4.0			μs
t <sub>HD,STA</sub>	Hold time (repeated) START	f <sub>SCL</sub> > 100kHz	0.6			μs
t <sub>SU,STA</sub>	Setup time for a repeated START	f <sub>SCL</sub> = 100kHz	4.7			μs
t <sub>SU,STA</sub>	Setup time for a repeated START	f <sub>SCL</sub> > 100kHz	0.6			μs
t <sub>HD,DAT</sub>	Data hold time		0			μs
t <sub>SU,DAT</sub>	Data setup time	f <sub>SCL</sub> = 100kHz	250			ns
t <sub>SU,DAT</sub>	Data setup time	f <sub>SCL</sub> > 100kHz	100			ns
t <sub>SU,STO</sub>	Setup time for STOP	f <sub>SCL</sub> = 100kHz	4.0			μs
t <sub>SU,STO</sub>	Setup time for STOP	f <sub>SCL</sub> > 100kHz	0.6			μs
t <sub>BUF</sub>	Bus free time between STOP and START conditions	f <sub>SCL</sub> = 100kHz	4.7			μs
t <sub>BUF</sub>	Bus free time between STOP and START conditions	f <sub>SCL</sub> > 100kHz	1.3			μs
t <sub>SP</sub>	Pulse duration of spikes suppressed by input deglitch filter		50			ns

### 7.19.3.2 I<sup>2</sup>C Timing Diagram

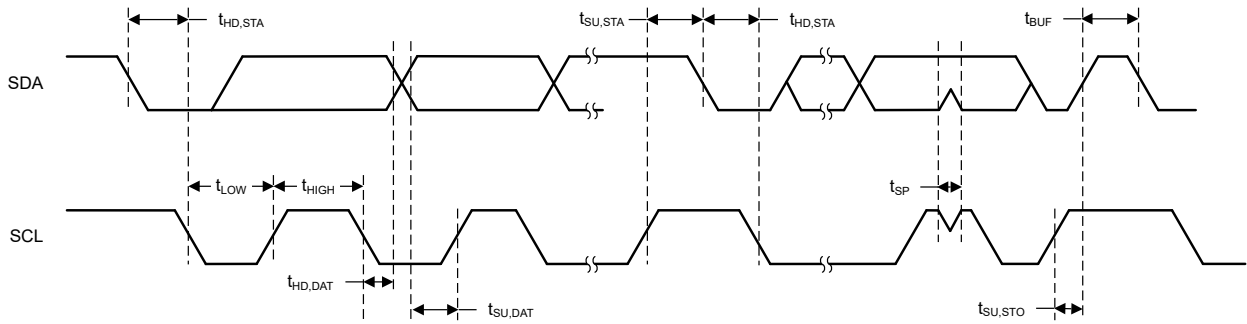


Figure 7-5. I<sup>2</sup>C Timing Diagram

## 7.19.4 GPIO

### 7.19.4.1 GPIO DC Characteristics

PARAMETER	TEST CONDITIONS	MIN	TYP	MAX	UNIT
<b>T<sub>A</sub> = 25°C, V<sub>DD5</sub> = 1.8V</b>					
GPIO VOH at 10 mA load	high-drive GPIOs only, max drive setting	1.15	1.54		V
GPIO VOL at 10 mA load	high-drive GPIOs only, max drive setting		0.25	0.50	V
GPIO VOH at 2 mA load	standard drive GPIOs	1.27	1.60		V
GPIO VOL at 2 mA load	standard drive GPIOs		0.19	0.35	V
GPIO pullup current	Input mode, pullup enabled, Vpad = 0V	39	66	109	μA
GPIO pulldown current	Input mode, pulldown enabled, Vpad = VDD5	10	21	40	μA
GPIO low-to-high input transition, with hysteresis	IH = 1, transition voltage for input read as 0 → 1	0.91	1.11	1.27	V
GPIO high-to-low input transition, with hysteresis	IH = 1, transition voltage for input read as 1 → 0	0.59	0.75	0.91	V
GPIO input hysteresis	IH = 1, difference between 0 → 1 and 1 → 0 points	0.26	0.35	0.44	V
<b>T<sub>A</sub> = 25°C, V<sub>DD5</sub> = 3.0V</b>					
GPIO VOH at 10 mA load	high-drive GPIOs only, max drive setting	2.47			V
GPIO VOL at 10 mA load	high-drive GPIOs only, max drive setting			0.25	V
GPIO VOH at 2 mA load	standard drive GPIOs	2.52			V
GPIO VOL at 2 mA load	standard drive GPIOs			0.20	V
<b>T<sub>A</sub> = 25°C, V<sub>DD5</sub> = 3.8V</b>					
GPIO pullup current	Input mode, pullup enabled, Vpad = 0V	170	262	393	μA
GPIO pulldown current	Input mode, pulldown enabled, Vpad = VDD5	60	110	172	μA
GPIO low-to-high input transition, with hysteresis	IH = 1, transition voltage for input read as 0 → 1	1.76	1.98	2.27	V
GPIO high-to-low input transition, with hysteresis	IH = 1, transition voltage for input read as 1 → 0	1.26	1.52	1.79	V
GPIO input hysteresis	IH = 1, difference between 0 → 1 and 1 → 0 points	0.40	0.47	0.54	V
<b>T<sub>A</sub> = 25°C</b>					
VIH	Lowest GPIO input voltage reliably interpreted as a <i>High</i>	0.8*V <sub>DD5</sub>			V
VIL	Highest GPIO input voltage reliably interpreted as a <i>Low</i>	0.2*V <sub>DD5</sub>			V

## 7.19.5 ADC

### 7.19.5.1 Analog-to-Digital Converter (ADC) Characteristics

$T_C = 25^\circ\text{C}$ ,  $V_{DD5} = 3.0\text{V}$ , unless otherwise noted.<sup>(2)</sup>

Performance numbers require use of offset and gain adjustments in software by TI-provided ADC drivers.

PARAMETER		TEST CONDITIONS	MIN	TYP	MAX	UNIT
<b>ADC Power Supply and Input Range Conditions</b>						
$V_{(Ax)}$	Analog input voltage range	All ADC analog input pins Ax	0		VDDS	V
$I_{(ADC)}$ single-ended mode	Operating supply current into VDDS terminal	RES = 0x0 (12Bit mode), $F_s = 1.2\text{MSPS}$ , Internal reference OFF (ADCREF_EN = 0), $V_{eREF+} = V_{DD5}$		480		$\mu\text{A}$
		RES = 0x0 (12Bit mode), $F_s = 266\text{ksps}$ , Internal reference ON (ADCREF_EN = 0), ADCREF = 2.5V		365		
$C_{I\text{GPIO}}$	Input capacitance into a single terminal			5	7	pF
$R_{I\text{GPIO}}$	Input MUX ON-resistance			0.5	1	k $\Omega$
<b>ADC Switching Characteristics</b>						
$F_S$ ADCREF	ADC sampling frequency when using the internal ADC reference voltage	ADCREF_EN = 1, RES = 0x0 (12-bit), VDDS = 1.71V to VDD5max			267 <sup>(1)</sup>	ksps
$F_S$ ADCREF	ADC sampling frequency when using the internal ADC reference voltage	ADCREF_EN = 1, RES = 0x1 (10-bit), VDDS = 1.71V to VDD5max			308 <sup>(1)</sup>	ksps
$F_S$ ADCREF	ADC sampling frequency when using the internal ADC reference voltage	ADCREF_EN = 1, RES = 0x2 (8-bit), VDDS = 1.71V to VDD5max			400 <sup>(1)</sup>	ksps
$F_S$ EXTREF	ADC sampling frequency when using the external ADC reference voltage	ADCREF_EN = 0, $V_{eREF+} = V_{DD5}$ , RES = 0x0 (12-bit), VDDS = 1.71V to VDD5max			1.2 <sup>(1)</sup>	MspS
$F_S$ EXTREF	ADC sampling frequency when using the external ADC reference voltage	ADCREF_EN = 0, $V_{eREF+} = V_{DD5}$ , RES = 0x1 (10-bit), VDDS = 1.71V to VDD5max			1.33 <sup>(1)</sup>	MspS
$F_S$ EXTREF	ADC sampling frequency when using the external ADC reference voltage	ADCREF_EN = 0, $V_{eREF+} = V_{DD5}$ , RES = 0x2 (8-bit), VDDS = 1.71V to VDD5max			1.6 <sup>(1)</sup>	MspS
$N_{\text{CONVERT}}$	Clock cycles for conversion	RES = 0x0 (12-bit)		14		cycles
$N_{\text{CONVERT}}$	Clock cycles for conversion	RES = 0x1 (10-bit)		12		cycles
$N_{\text{CONVERT}}$	Clock cycles for conversion	RES = 0x2 (8-bit)		9		cycles
$t_{\text{sample}}$	Sampling time	RES = 0x0 (12-bit), $R_S = 25\Omega$ , $C_{\text{pext}} = 10\text{pF} \pm 0.5$ LSB settling	250			ns
$t_{V_{\text{SUPPLY}}/3(\text{sample})}$	Sample time required when $V_{\text{supply}}/3$ channel is selected		20			$\mu\text{s}$
<b>ADC Linearity Parameters</b>						
$E_I$	Integral linearity error (INL) for single-ended inputs	12-bit Mode, $V_{R+} = V_{eREF+} = V_{DD5}$ , VDDS=1.71-->3.8		+/- 2		LSB
$E_D$	Differential linearity error (DNL)	12-bit Mode, $V_{R+} = V_{eREF+} = V_{DD5}$ , VDDS=1.71-->3.8		+/- 1		LSB
$E_O$	Offset error	12-bit Mode, External reference, $V_{R+} = V_{eREF+} = V_{DD5}$ , VDDS=1.71-->3.8		1.98		LSB
$E_O$	Offset error	12-bit Mode, Internal reference, $V_{R+} = \text{ADCREF} = 2.5\text{V}$		1.02		LSB
$E_G$	Gain error	External Reference, $V_{R+} = V_{eREF+} = V_{DD5}$ , VDD= 1.71-->3.8		+/- 2		LSB
$E_G$	Gain error	Internal reference, $V_{R+} = \text{ADCREF} = 2.5\text{V}$		+/- 40		LSB
<b>ADC Dynamic Parameters</b>						
ENOB	Effective number of bits	ADCREF_EN = 0, $V_{eREF+} = V_{DD5} = 3.3\text{V}$ , $V_{eREF-} = 0\text{V}$ , RES = 0x2 (8-bit)		8		bit
ENOB	Effective number of bits	ADCREF_EN = 0, $V_{eREF+} = V_{DD5} = 3.3\text{V}$ , $V_{eREF-} = 0\text{V}$ , RES = 0x1 (10-bit)		9.9		bit

### 7.19.5.1 Analog-to-Digital Converter (ADC) Characteristics (continued)

$T_c = 25^\circ\text{C}$ ,  $V_{\text{DD5}} = 3.0\text{V}$ , unless otherwise noted.<sup>(2)</sup>

Performance numbers require use of offset and gain adjustments in software by TI-provided ADC drivers.

PARAMETER		TEST CONDITIONS	MIN	TYP	MAX	UNIT
ENOB	Effective number of bits	ADCREP_EN = 0, VeREF+ = VDD5 = 3.3V, VeREF- = 0V, RES = 0x0 (12-bit)		11.2		bit
ENOB	Effective number of bits	ADCREP_EN = 1, ADCREF_VSEL = {2.5V, 1.4V}, RES = 0x2 (8-bit)		8		bit
ENOB	Effective number of bits	ADCREP_EN = 1, ADCREF_VSEL = {2.5V, 1.4V}, RES = 0x1 (10-bit)		9.6		bit
ENOB	Effective number of bits	ADCREP_EN = 1, ADCREF_VSEL = {2.5V, 1.4V}, RES = 0x0 (12-bit)		10.4		bit
ENOB	Effective number of bits	VDD5 reference, RES = 0x0 (12-bit)		11.2		bit
SINAD	Signal-to-noise and distortion ratio	ADCREP_EN = 0, VeREF+ = VDD5 = 3.3V, VeREF- = 0V, RES = 0x0 (12-bit)		69.18		dB
SINAD	Signal-to-noise and distortion ratio	ADCREP_EN = 1, ADCREF_VSEL = {2.5V, 1.4V}, RES = 0x0 (12-bit)		64.37		dB
SINAD	Signal-to-noise and distortion ratio	VDD5 reference, RES = 0x0 (12-bit)		69.18		dB
<b>ADC External Reference</b>						
EXTREF	Positive external reference voltage input	ADCREP_EN=0, ADC reference sourced from external reference pin (VeREF+)	1.4		VDD5	V
EXTREF	Negative external reference voltage input	ADCREP_EN=0, ADC reference sourced from external reference pin (VeREF-)			0	V
<b>ADC Temperature Diode, Supply Monitor</b>						
Temp_diode Accuracy	Temperature Error	ADC input channel: Temp diode voltage, Error calculated in temperature range: -30C to +40C, with single point calibration <sup>(2)</sup>		+/- 3		C
ADC Internal Input: V <sub>SUPPLY</sub> / 3 Accuracy	V <sub>supply</sub> voltage divider accuracy for supply monitoring	ADC input channel: Vsupply monitor		+/- 1		%
ADC Internal Input: I <sub>Vsupply</sub> / 3	V <sub>supply</sub> voltage divider current consumption	ADC input channel Vsupply monitor. V <sub>supply</sub> =VDD5=3.3V		10		μA
<b>ADC Internal and VDD5 Reference</b>						
VDD5REF	Positive ADC reference voltage	ADC reference sourced from VDD5		VDD5		V
ADCREP	Internal ADC Reference Voltage	ADCREP_EN = 1, ADCREF_VSEL = 0, VDD5 = 1.71V - VDD5max		1.4		V
		ADCREP_EN = 1, ADCREF_VSEL = 1, VDD5 = 2.7V - VDD5max		2.5		V
I <sub>ADCREP</sub>	Operating supply current into VDDA terminal with internal reference ON	ADCREP_EN = 1, VDDA = 1.7V to VDDAmax, ADCREF_VSEL = {0,1}		80		μA
t <sub>ON</sub>	Internal ADC Reference Voltage power on-time	ADCREP_EN = 1		2		μs

(1) Measured with 48MHz HFOSC

(2) Using IEEE Std 1241-2010 for terminology and test methods

## 7.19.6 Comparators

### 7.19.6.1 Ultra-Low Power Comparator

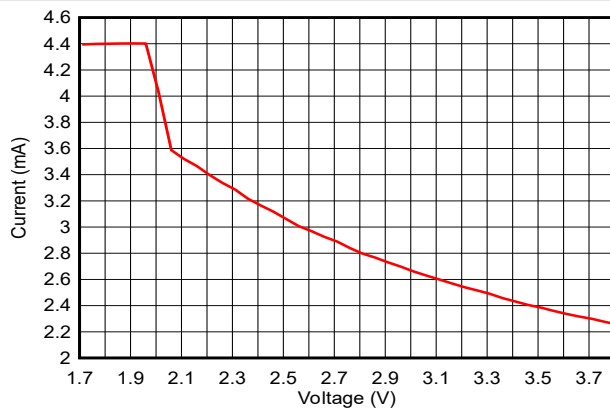
$T_c = 25^\circ\text{C}$ ,  $V_{\text{DDS}} = 3.0\text{V}$ , unless otherwise noted.

PARAMETER	TEST CONDITIONS	MIN	TYP	MAX	UNIT
Input voltage range		0		$V_{\text{DDS}}$	V
Clock frequency			32		KHz
Voltage Divider Accuracy	Input voltage range is between $V_{\text{DDS}}/4$ and $V_{\text{DDS}}$		98		%
Offset	Measured at $V_{\text{DDS}} / 2$ (Errors seen when using two external inputs )		+/- 27.3		mV
Decision time	Step from $-50\text{mV}$ to $50\text{mV}$		1	3	Clock Cycle
Comparator enable time	COMP_LP disable → enable, VIN+, VIN- from pins, Overdrive $\geq 20\text{mV}$		70		$\mu\text{s}$
Current consumption	Including using $V_{\text{DDS}}/2$ as internal reference at VIN- comparator terminal		370		nA

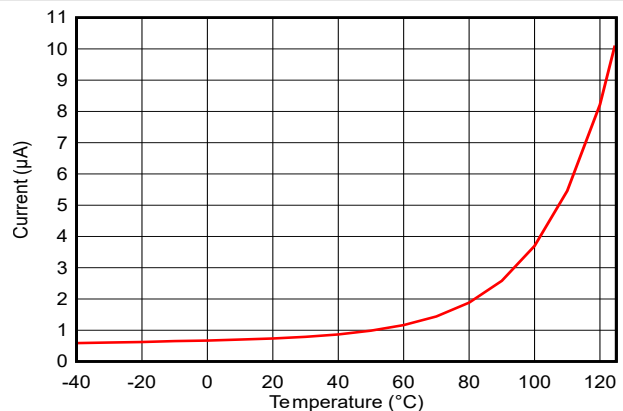
## 7.20 Typical Characteristics

All measurements in this section are done with  $T_c = 25^\circ\text{C}$  and  $V_{\text{DDS}} = 3.0\text{V}$ , unless otherwise noted. See *Recommended Operating Conditions* for device limits. Values exceeding these limits are for reference only.

### 7.20.1 MCU Current

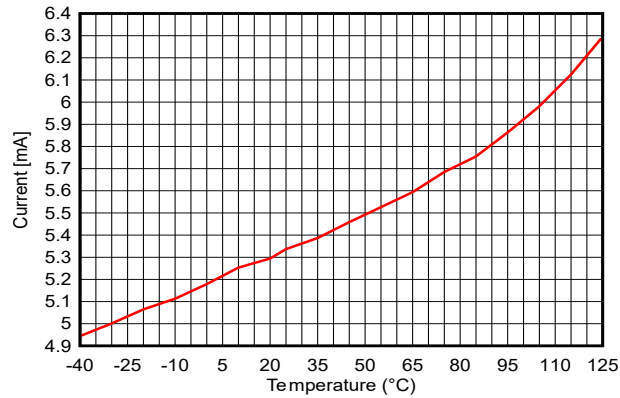


**Figure 7-6. Active Mode (MCU) Current vs Supply Voltage ( $V_{\text{DDS}}$ ) (Running CoreMark)**

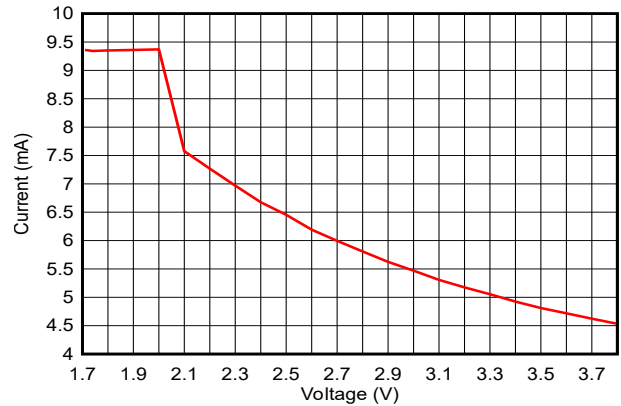


**Figure 7-7. Standby Mode (MCU) Current vs Temperature (RAM and Partial Register Retention, RTC)**

**7.20.2 RX Current**

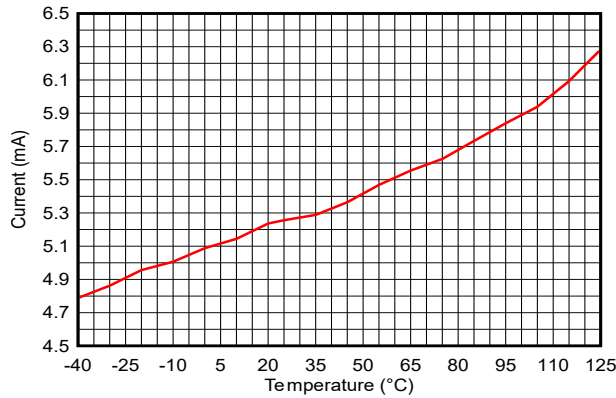


**Figure 7-8. RX Current vs Temperature (BLE 1Mbps, 2.44GHz)**

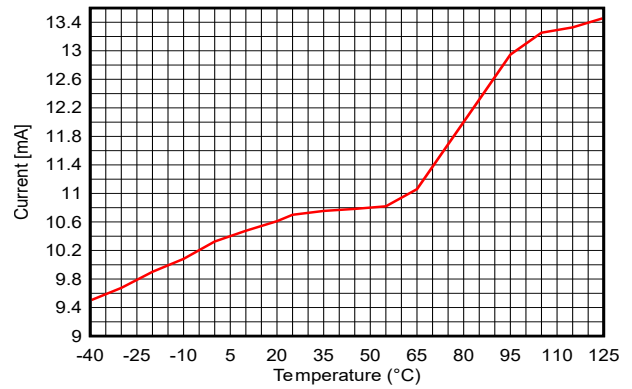


**Figure 7-9. RX Current vs Supply Voltage (VDD5) (BLE 1Mbps, 2.44GHz)**

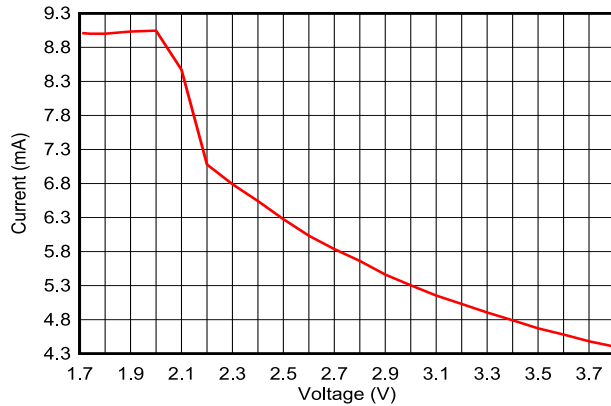
### 7.20.3 TX Current



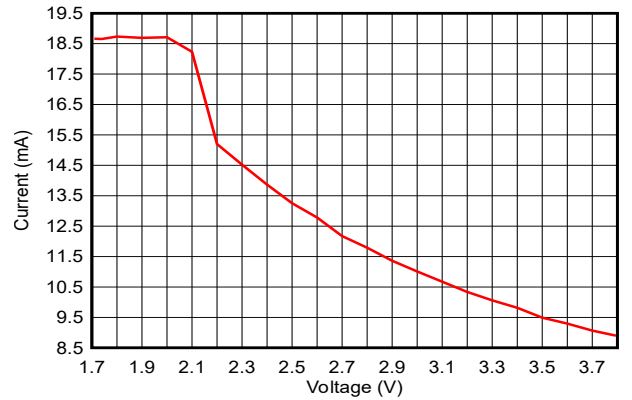
**Figure 7-10. TX Current vs Temperature (BLE 1Mbps, 2.44GHz, 0dBm)**



**Figure 7-11. TX Current vs Temperature (BLE 1Mbps, 2.44GHz, +8dBm)**



**Figure 7-12. TX Current vs Supply Voltage, VDD5 (BLE 1Mbps, 2.44GHz, 0dBm)**



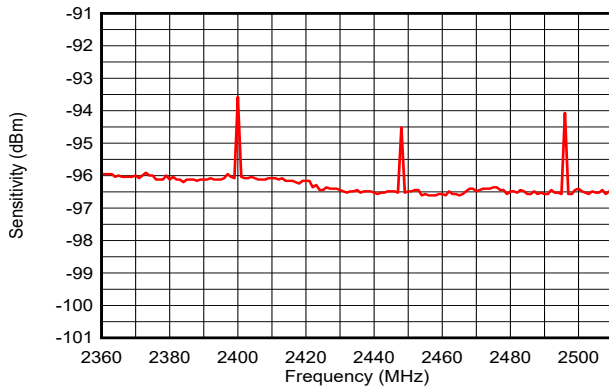
**Figure 7-13. TX Current vs Supply Voltage, VDD5 (BLE 1Mbps, 2.44GHz, +8dBm)**

Table 7-1 shows typical TX current and output power for different output power settings.

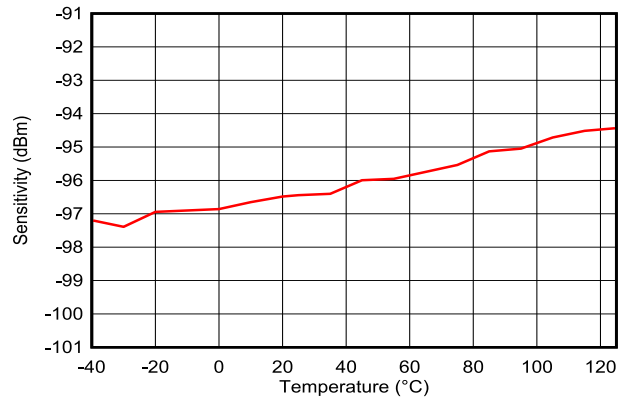
**Table 7-1. Typical TX Current and Output Power**

2.4GHz, VDDS = 3.0V, DCDC=On, Temperature = 25°C (Measured on LP-EM-CC2340R5)			
txPowerTable Index	TX Power Setting [dBm] (SmartRF Studio)	Typical Output Power [dBm]	Typical Current Consumption [mA]
13	8	7.7	10.7
12	7	7.1	9.5
11	6	6.3	8.9
10	5	5.5	8.3
9	4	4.5	7.9
8	3	3.7	7.5
7	2	2.4	7.1
6	1	1.0	5.4
5	0	0.4	5.1
4	-4	-3.1	4.8
3	-8	-7.3	4.5
2	-12	-10.9	4.2
1	-16	-15.1	4.0
0	-20	-19.0	3.8

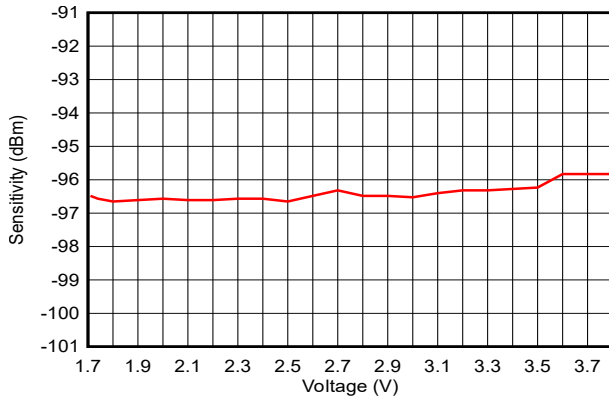
### 7.20.4 RX Performance



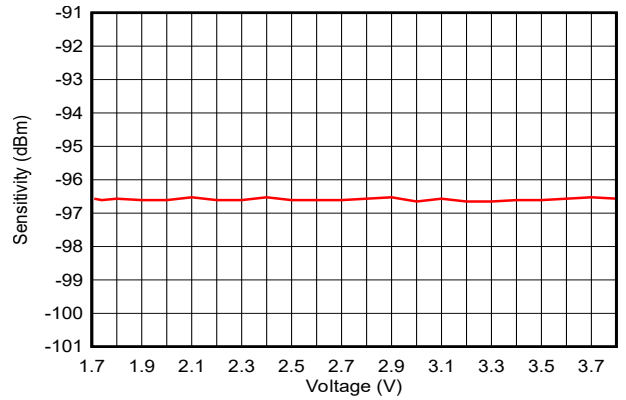
**Figure 7-14. Sensitivity vs Frequency (BLE 1Mbps)**



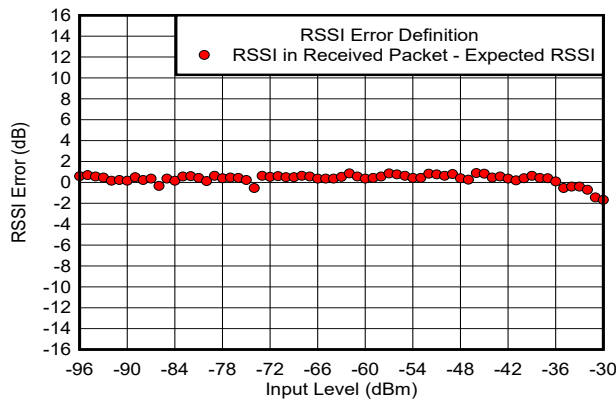
**Figure 7-15. Sensitivity vs Temperature (BLE 1Mbps, 2.44GHz)**



**Figure 7-16. Sensitivity vs Supply Voltage (VDD5) (BLE 1Mbps, 2.44GHz)**

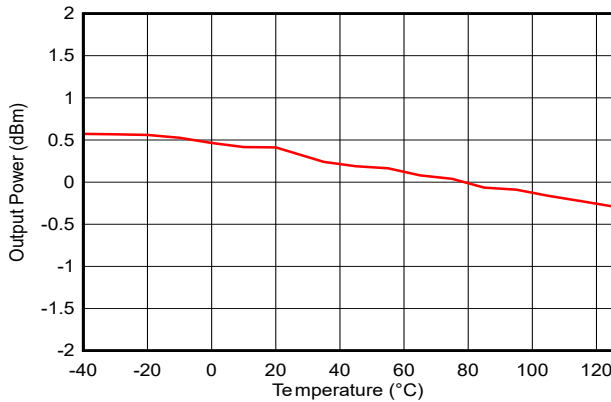


**Figure 7-17. Sensitivity vs Supply Voltage (VDD5) (BLE 1Mbps, 2.44GHz, DCDC Off)**

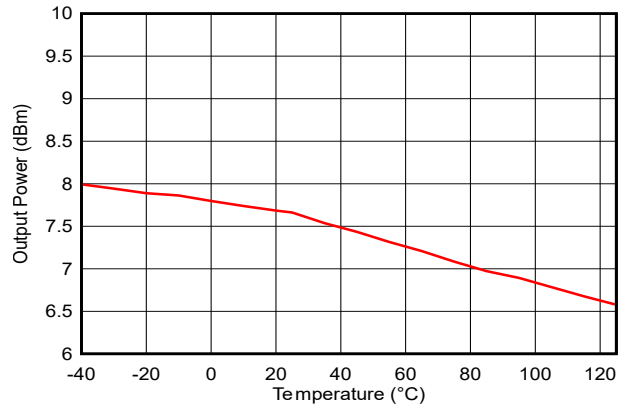


**Figure 7-18. RSSI Error vs Input Level (dBm)**

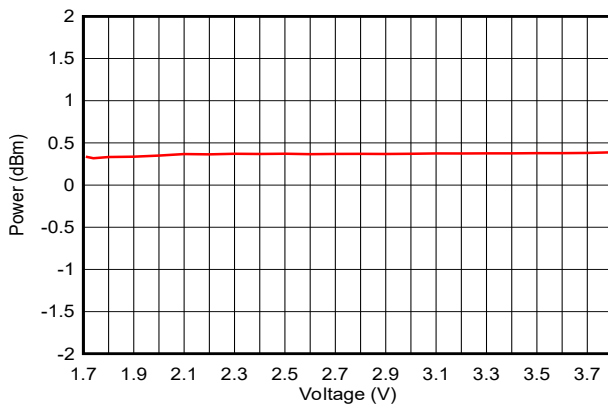
**7.20.5 TX Performance**



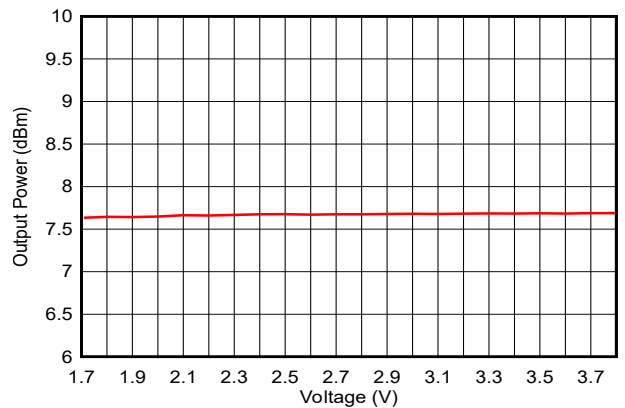
**Figure 7-19. Output Power vs Temperature (BLE 1Mbps, 2.44GHz, 0dBm)**



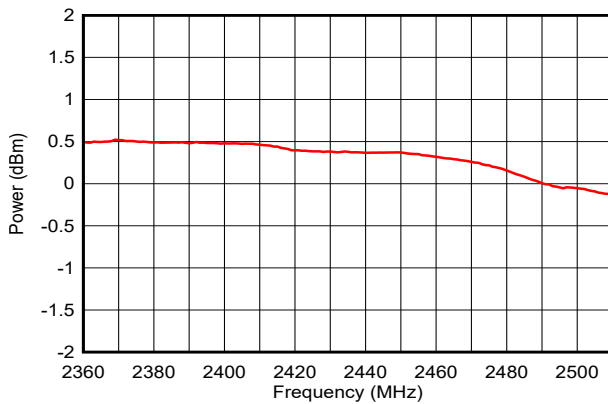
**Figure 7-20. Output Power vs Temperature (BLE 1Mbps, 2.44GHz, +8dBm)**



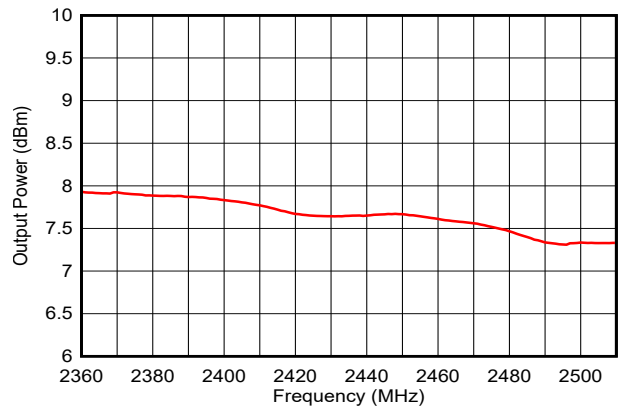
**Figure 7-21. Output Power vs Supply Voltage (VDD5) (BLE 1Mbps, 2.44GHz, 0dBm)**



**Figure 7-22. Output Power vs Supply Voltage (VDD5) (BLE 1Mbps, 2.44GHz, +8dBm)**



**Figure 7-23. Output Power vs Frequency (BLE 1Mbps, 0dBm)**



**Figure 7-24. Output Power vs Frequency (BLE 1Mbps, +8dBm)**

### 7.20.6 ADC Performance

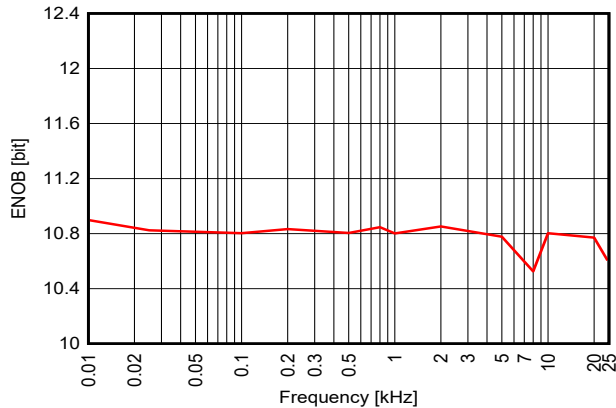


Figure 7-25. ENOB vs Input Frequency (Internal Reference)

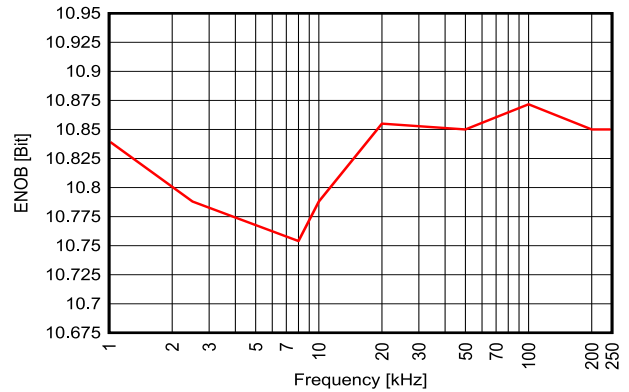


Figure 7-26. ENOB vs Sampling Frequency ( $V_{in} = 3V$  Sine Wave, Internal Reference,  $F_{in} = F_s/10$ )

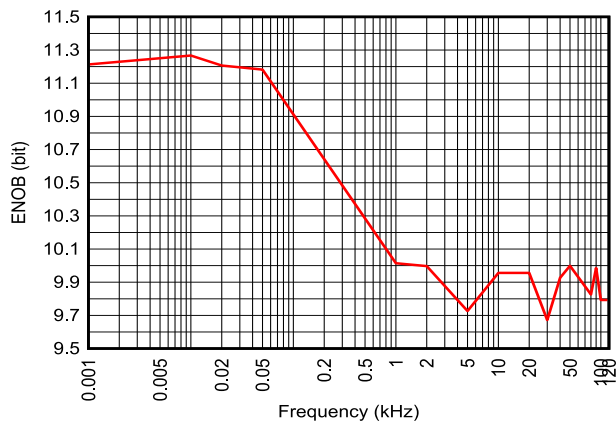


Figure 7-27. ENOB vs Input Frequency (External Reference = 3.0V)

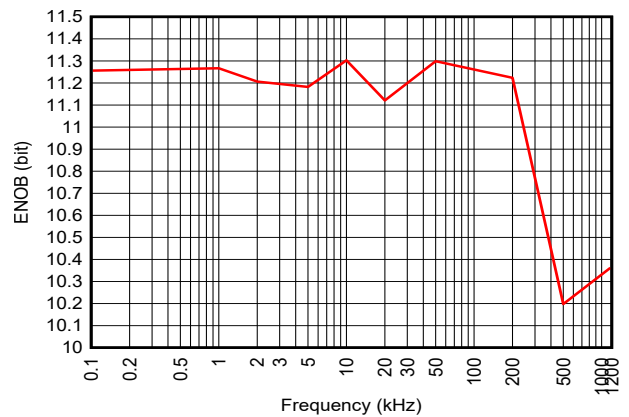


Figure 7-28. ENOB vs Sampling Frequency ( $V_{in} = 3V$  Sine Wave, External Reference = 3.0V,  $F_{in} = F_s/10$ )

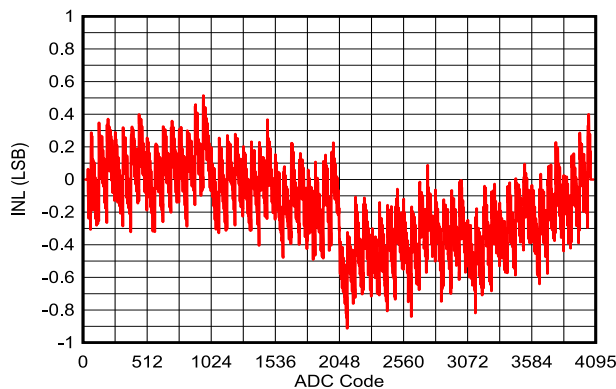


Figure 7-29. INL vs ADC Code ( $V_{in} = 3V$  Sine Wave, Internal Reference, 200ksps)

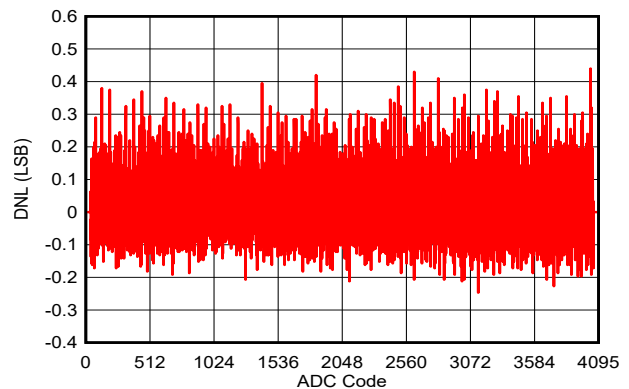
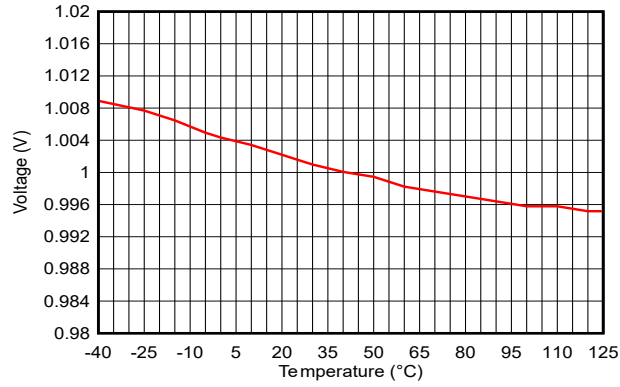
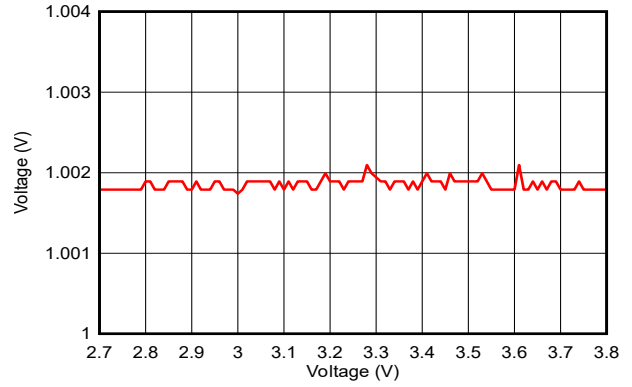


Figure 7-30. DNL vs ADC Code ( $V_{in} = 3V$  Sine Wave, Internal Reference, 200ksps)



**Figure 7-31. ADC Accuracy vs Temperature ( $V_{in}=1V$ , Internal Reference, 200ksps)**



**Figure 7-32. ADC Accuracy vs Supply Voltage ( $V_{in}=1V$ , Internal Reference, 200ksps)**

## 8 Detailed Description

### 8.1 Overview

[Section 4](#) shows the core modules of the CC2340R5-Q1 device.

### 8.2 System CPU

The CC2340R5-Q1 SimpleLink™ Wireless MCU contains an Arm® Cortex®-M0+ system CPU, which runs the application, the protocol stacks, and the radio. The Cortex-M0+ processor is built on a highly area and power-optimized 32-bit processor core, with a 2-stage pipeline Von Neumann architecture. The processor delivers exceptional energy efficiency through a small but powerful instruction set and extensively optimized design, providing high-end processing hardware, including a single-cycle multiplier. The Cortex-M0+ processor offers multiple benefits to developers, including:

- Ultra-low power, energy-efficient operation
- Deterministic, high-performance interrupt handling for time-critical applications
- Upward compatibility with the Cortex-M processor family

The Cortex-M0+ processor provides the excellent performance expected of a modern 32-bit architecture core, with higher code density than other 8-bit and 16-bit microcontrollers. Its features include the following:

- ARMv6-M architecture optimized for small-footprint embedded applications
- A subset of Arm Thumb/Thumb-2 mixed 16- and 32-bit instructions delivers the high performance expected of a 32-bit Arm
- Single-cycle multiply instruction
- VTOR supporting offset of the vector table base address
- Serial Wire debug with HW break-point comparators
- Ultra-low-power consumption with integrated sleep modes
- SysTick timer
- 48MHz operation
- 0.99DMIPS/MHz

Additionally, the CC2340Rx devices are compatible with all ARM tools and software.

## 8.3 Radio (RF Core)

The low-power RF Core (LRF) implements a high-performance and highly flexible RF subsystem containing RF and baseband circuitry in addition to a software-defined digital radio (LRFD). LRFD provides a high-level, command-based API to the main CPU and handles all of the timing critical and low-level details of many different radio PHYs. Several signals are also available to control external circuitry, such as RF switches or range extenders, autonomously.

The software-defined modem is not programmable by customers but is instead loaded with pre-compiled images provided in the radio driver in the SimpleLink™ Low Power F3 software development kit (SDK) for the CC23xx devices. This mechanism allows the radio platform to be updated for support of future versions of standards with over-the-air (OTA) updates while still using the same silicon. LRFD stores the code images in the RF SRAM and does not make use of any ROM memory, thus, image loading from NV memory only occurs once after boot, and no patching is required when exiting power modes.

### 8.3.1 Bluetooth 5.4 Low Energy

The RF Core offers full support for Bluetooth 5.4 Low Energy, including the high-speed 2Mbps physical layer and the 500kbps and 125kbps long-range PHYs (Coded PHY) through the TI-provided Bluetooth 5.4 stack or through a high-level Bluetooth API.

The new high-speed mode allows data transfers up to 2Mbps, twice the speed of Bluetooth 4.2 and five times the speed of Bluetooth 4.0, without increasing power consumption. In addition to faster speeds, this mode offers significant improvements for energy efficiency and wireless coexistence with reduced radio communication time.

Bluetooth 5.4 also enables unparalleled flexibility for adjustment of speed and range based on application needs, which capitalizes on the high-speed or long-range modes, respectively. Data transfers are now possible at 2Mbps, enabling the development of applications using voice, audio, imaging, and data logging that were not previously an option using Bluetooth low energy. With high-speed mode, existing applications deliver faster responses, richer engagement, and longer battery life. Bluetooth 5.4 enables fast, reliable firmware updates.

## 8.4 Memory

The 512KB nonvolatile (Flash) memory provides storage for code and data. The flash memory is in-system programmable and erasable. A special flash memory sector must contain a Customer Configuration section (CCFG) that is used by the boot ROM and TI-provided drivers to configure the device. This configuration is done through the `ccfg.c` source file that is included in all TI-provided examples.

Up to 64KB ultra-low leakage system static RAM (SRAM) can be used for both storage of data and execution of code. Retention of SRAM contents in Standby power mode is enabled by default and included in Standby mode power consumption numbers. System SRAM is always initialized to zeroes upon code execution during boot.

The ROM includes device bootcode firmware handling initial device trimming operations, security configurations, and device lifecycle management. The ROM also contains a serial (SPI and UART) bootloader that can be used for the initial programming of the device.

## 8.5 Cryptography

The CC2340R5-Q1 device comes with an AES-128 cryptography hardware accelerator, reducing code footprint and execution time for cryptographic operations. It also has the benefit of being lower power and improves the availability and responsiveness of the system because the cryptography operations run in a background hardware thread. The AES hardware accelerators support the following block cipher modes and message authentication codes:

- AES ECB encrypt
- AES CBC encrypt
- AES CTR encrypt/decrypt
- AES CBC-MAC
- AES GCM
- AEC CCM (uses a combination of CTR + CBC-MAC hardware via software drivers)

The AES hardware accelerator can be fed with plaintext/ciphertext from either the CPU or using DMA. Sustained throughput of one 16-byte ECB block per 23 cycles is possible, corresponding to > 30Mbps.

The CC2340R5-Q1 device supports Random Number Generation (RNG) using on-chip analog noise as the non-deterministic noise source for the purpose of generating a seed for a cryptographically secure counter deterministic random bit generator (CTR-DRBG) that in turn is used to generate random numbers for keys, initialization vectors (IVs), and other random number requirements. Hardware acceleration of AES CTR-DRBG is supported.

The CC2340R5-Q1 device includes a complete SHA-256 library in ROM, reducing the code footprint of the application. Use cases may include generating digests for use in digital signature algorithms, data integrity checks, and password storage.

Together with a large selection of open-source cryptography libraries provided with the Software Development Kit (SDK), this allows for secure and future-proof IoT applications to be easily built on top of the platform.

## 8.6 Timers

A large selection of timers is available as part of the CC2340R5-Q1 device. These timers are:

- **Real-Time Clock (RTC)**

The RTC is a 67-bit, 2-channel timer running on the LFCLK system clock. The RTC is active in STANDBY and ACTIVE power states. When the device enters the RESET or SHUTDOWN state, the RTC is reset.

The RTC accumulates the time elapsed since reset on each LFCLK. The RTC counter is incremented by LFINC at a rate of 32.768kHz. LFINC indicates the period of LFCLK in  $\mu$ s, with an additional granularity of 16 fractional bits.

The counter can be read from two 32-bit registers. RTC.TIME8U has a range of approximately 9.5 hours with an LSB representing 8 microseconds. RTC.TIME524M has a range of approximately 71.4 years with an LSB representing 524 milliseconds.

There is hardware synchronization between the system timer (SYSTIM) and the RTC so that the multichannel and higher resolution SYSTIM remains in synchronization with the RTC's time base.

The RTC has two channels: one compare channel and one capture channel, and is capable of waking the device out of the standby power state. The RTC compare channel is typically used only by system software and only during the standby power state.

- **System Timer (SYSTIM)**

The SYSTIM is a 34-bit, 5-channel wrap-around timer with a per-channel selectable 32b slice with either a 1 $\mu$ s resolution and 1h11m35s range or 250ns resolution and 17m54s range. All channels support both capture and single-shot compare (posting an event) operations. One channel is reserved for system software, three channels are reserved for radio software, and one channel is freely available to user applications.

For software convenience, a hardware synchronization mechanism automatically ensures that the RTC and SYSTIM share a common time base (albeit with different resolutions/spans). Another software convenience feature is that SYSTIM qualifies any submitted compare values so that the timer channel will immediately trigger if the submitted event is in the immediate past (4.294s with 1 $\mu$ s resolution and 1.049s with 250ns resolution).

- **General Purpose Timers (LGPT)**

The CC2340R5-Q1 device provides four LGPTs with 3  $\times$  16 bit timers and 1  $\times$  24-bit timer, all running up to 48MHz. The LGPTs support a wide range of features such as:

- Three capture/compare channels
- One-shot or periodic counting
- Pulse width modulation (PWM)
- Time counting between edges and edge counting
- Input filter implemented on each of the channels for all timers
- IR generation feature available on Timer-0 and Timer-1
- Deadband feature available on Timer-1

The timer capture/compare and PWM signals are connected to IOs through the IO controller module (IOC), and the internal timer event connections to CPU, DMA, and other peripherals are through the event fabric, which allows the timers to interact with signals such as GPIO inputs, other timers, DMA, and ADC. Two LGPTs (2  $\times$  16-bit timers) support quadrature decoder mode to enable buffered decoding of quadrature-encoded sensor signals. The LGPTs are available in device Active and Idle power modes.

**Table 8-1. Timer Comparison**

Feature	Timer 0	Timer 1	Timer 2	Timer 3
Counter Width	16-bit	16-bit	16-bit	24-bit
Quadrature Decoder	Yes	No	Yes	No
Park Mode on Fault	No	Yes	No	No
Programmable Dead-Band Insertion	No	Yes	No	No

- **Watchdog timer**

The watchdog timer is used to regain control if the system operates incorrectly due to software errors. Upon counter expiry, the watchdog timer resets the device when periodic monitoring of the system components and tasks fails to verify proper functionality. The watchdog timer runs on a 32kHz clock rate and operates in device active, idle, and standby modes, and cannot be stopped once enabled.

## 8.7 Serial Peripherals and I/O

The CC2340R5-Q1 device provides 1xUART, 1xSPI, and 1xI2C serial peripherals

The SPI module supports both SPI controller and peripheral up to 12MHz with configurable phase and polarity.

The UART module implements universal asynchronous receiver and transmitter functions. They support flexible baud-rate generation up to a maximum of 3Mbps and IRDA SIR mode of operation.

The I<sup>2</sup>C module is used to communicate with devices compatible with the I<sup>2</sup>C standard. The I<sup>2</sup>C interface can handle 100kHz and 400kHz operation and can serve as both controller and target.

The I/O controller (IOC) controls the digital I/O pins and contains multiplexer circuitry to allow a set of peripherals to be assigned to I/O pins in a fixed manner over DIOs. All digital I/Os are interrupt and wake-up capable, have a programmable pullup and pulldown function, and can generate an interrupt on a negative or positive edge (configurable). When configured as an output, pins can function as either push-pull, open-drain, or open-source. Some GPIOs have high-drive capabilities, which are marked in **bold** in [Section 6](#).

For more information, see the [CC23xx SimpleLink™ Wireless MCU Technical Reference Manual](#).

## 8.8 Battery and Temperature Monitor

A combined temperature and battery voltage monitor is available in the CC2340R5-Q1 device. The battery and temperature monitor allows an application to continuously monitor on-chip temperature and supply voltage and respond to changes in environmental conditions as needed. The module contains window comparators to interrupt the system CPU when the temperature or supply voltage goes outside defined windows. These events can also be used to wake up the device from Standby mode through the Always-On (AON) event fabric.

## 8.9 $\mu$ DMA

The device includes a direct memory access ( $\mu$ DMA) controller. The  $\mu$ DMA controller provides a way to offload data-transfer tasks from the system CPU, thus allowing for more efficient use of the processor and the available bus bandwidth. The  $\mu$ DMA controller can perform a transfer between memory and peripherals. The  $\mu$ DMA controller has dedicated channels for each supported on-chip module and can be programmed to automatically perform transfers between peripherals and memory when the peripheral is ready to transfer more data.

Some features of the  $\mu$ DMA controller include the following (this is not an exhaustive list):

- Channel operation of up to 8 channels, with 6 channels having a dedicated peripheral interface and 2 channels having the ability to be triggered through configurable events.
- Transfer modes: memory-to-memory, memory-to-peripheral, peripheral-to-memory, and peripheral-to-peripheral
- Data sizes of 8, 16, and 32 bits
- Ping-pong mode for continuous streaming of data

## 8.10 Debug

On-chip debug is supported through the serial wire debug (SWD) interface, which is an ARM bidirectional 2-wire protocol that communicates with the JTAG Test Access Port (TAP) controller and allows for complete debug functionality. SWD is fully compatible with Texas Instruments' XDS family of debug probes.

## 8.11 Power Management

To minimize power consumption, the CC2340R5-Q1 supports a number of power modes and power management features (see [Table 8-2](#)).

**Table 8-2. Power Modes**

MODE	SOFTWARE CONFIGURABLE POWER MODES <sup>(1)</sup>				RESET PIN HELD
	ACTIVE	IDLE	STANDBY	SHUTDOWN	
CPU	Active	Off	Off	Off	Off
Flash	On	Available	Off	Off	Off
SRAM	On	On	Retention	Off	Off
Radio	Available	Available	Off	Off	Off
Supply System	On	On	Duty Cycled	Off	Off
CPU register retention	Full	Full	Full <sup>(2)</sup>	No	No
SRAM retention	Full	Full	Full	Off	Off
48MHz high-speed clock (HFCLK)	HFOSC (tracks HFXT)	HFOSC (tracks HFXT)	Off	Off	Off
32kHz low-speed clock (LFCLK)	LFXT or LFOSC	LFXT or LFOSC	LFXT or LFOSC	Off	Off
Peripherals	Available	Available	IOC, BATMON, RTC, LPCOMP	Off	Off
Wake-up on RTC	N/A	Available	Available	Off	Off
Wake-up on pin edge	N/A	Available	Available	Available	Off
Wake-up on reset pin	On	On	On	On	On
Brownout detector (BOD)	On	On	Duty Cycled	Off	Off
Power-on reset (POR)	On	On	On	On	On
Watchdog timer (WDT)	Available	Available	Available	Off	Off

(1) "Available" indicates that the specific IP or feature can be enabled by a user application in the corresponding device operating modes. "On" indicates that the specific IP or feature is turned on, irrespective of the user application configuration of the device in the corresponding device operating mode. "Off" indicates that the specific IP or feature is turned off and not available for the user application in the corresponding device operating mode.

(2) Software-based retention of CPU registers with context save and restore when entering and exiting standby power mode

In the **Active** mode, both of MCU and AON power domains are powered. Clock gating is used to minimize power consumption. Clock gating to peripherals/subsystems is controlled manually by the CPU.

In **Idle** mode, the CPU is in sleep, but selected peripherals and subsystems (such as the radio) can be active. Infrastructure (Flash, ROM, SRAM, bus) clock gating is possible depending on the state of the DMA and debug subsystem.

In **Standby** mode, only the always-on (AON) domain is active. An external wake-up event, RTC event, or comparator event (LP-COMP) is required to bring the device back to active mode. Pin Reset will also drive the device from Standby to Active. MCU peripherals with retention do not need to be reconfigured when waking up again, and the CPU continues execution from where it went into standby mode. All GPIOs are latched in standby mode.

In **Shutdown** mode, the device is entirely turned off (including the AON domain), and the I/Os are latched with the value they had before entering shutdown mode. A change of state on any I/O pin defined as a *wake from shutdown pin* wakes up the device and functions as a reset trigger. The CPU can differentiate between reset in this way and reset-by-reset pin or power-on reset, or thermal shutdown reset, by reading the reset status register. The only states retained in this mode are the latched I/O state, 3V register bank, and the flash memory contents.

---

### Note

The power, RF, and clock management for the CC2340R5-Q1 device require specific configuration and handling by software for optimized performance. This configuration and handling are implemented in the TI-provided drivers that are part of the CC2340R5-Q1 software development kit (SDK). Therefore, TI highly recommends using this software framework for all application development on the device. The complete [SDK](#) with FreeRTOS, device drivers, and examples are offered free of charge in source code.

---

## 8.12 Clock Systems

The CC2340R5-Q1 device has the following internal system clocks.

The 48MHz HFCLK is used as the main system (MCU and peripherals) clock. This is driven by the internal 48MHz RC Oscillator (HFOSC), which can track its accuracy against an external 48MHz crystal (HFXT). Radio operation requires an external 48MHz crystal.

The 32.768kHz LFCLK is used as the internal low-frequency system clock. It is used for the RTC, the watchdog timer (if enabled in standby power mode), and to synchronize the radio timer before or after Standby power mode. LFCLK can be driven by the internal 32.8kHz RC Oscillator (LFOSC), a 32.768kHz watch-type crystal, or clock input in LFXT bypass mode. When using a crystal or the internal RC oscillator, the device can output the 32kHz LFCLK signal to other devices, thereby reducing the overall system cost.

## 8.13 Network Processor

Depending on the product configuration, the CC2340R5-Q1 device can function as a wireless network processor (WNP), a device running the wireless protocol stack with the application running on a separate host MCU, or as a system-on-chip (SoC), with the application and protocol stack running on the system CPU inside the device.

In the first case, the external host MCU communicates with the device using SPI or UART. In the second case, the application must be written according to the application framework supplied with the wireless protocol stack.

## 9 Application, Implementation, and Layout

---

### Note

Information in the following applications sections is not part of the TI component specification, and TI does not warrant its accuracy or completeness. TI's customers are responsible for determining suitability of components for their purposes, as well as validating and testing their design implementation to confirm system functionality.

---

### 9.1 Reference Designs

The following reference designs should be followed closely when implementing designs using the CC2340R5-Q1 device.

Special attention must be paid to RF component placement, decoupling capacitors and DCDC regulator components, as well as ground connections for all of these.

#### [LP-EM-CC2340R5 Design Files](#)

The CC2340R5 LaunchPad Design Files contain detailed schematics and layouts to build application-specific boards using the CC2340R5-Q1 device.

#### [Sub-1 GHz and 2.4 GHz Antenna Kit for LaunchPad™ Development Kit and SensorTag](#)

The antenna kit allows real-life testing to identify the optimal antenna for your application. The antenna kit includes 16 antennas for frequencies from 169MHz to 2.4GHz, including:

- PCB antennas
- Helical antennas
- Chip antennas
- Dual-band antennas for 868MHz and 915MHz combined with 2.4GHz

The antenna kit includes a JSC cable to connect to the Wireless MCU LaunchPad Development Kits and SensorTags.

## 9.2 Junction Temperature Calculation

This section shows the different techniques for calculating the junction temperature under various operating conditions. For more details, see [Semiconductor and IC Package Thermal Metrics](#).

There are two recommended ways to derive the junction temperature from other measured temperatures:

1. From package temperature:

$$T_J = \psi_{JT} \times P + T_{\text{case}} \quad (1)$$

2. From board temperature:

$$T_J = \psi_{JB} \times P + T_{\text{board}} \quad (2)$$

P is the power dissipated from the device and can be calculated by multiplying the current consumption with the supply voltage. Thermal resistance coefficients are found in *Thermal Resistance Characteristics*.

### Example:

In this example, we assume a simple use case where the radio is transmitting continuously at 0dBm output power. Let us assume we want to maintain a junction temperature equal or less than 85°C and the supply voltage is 3V. Using Equation 1, the temperature difference between the top of the case and the junction temperature is calculated. To calculate P, look up the current consumption for Tx at 85°C. At 85°C, the current consumption is approximately 5.5mA. This means that P is 5.5mA × 3V = 16.5mW.

The maximum case temperature to maintain and the junction temperature of 85°C are then calculated as:

$$T_{\text{case}} < T_J - 0.4^{\circ}\text{C}/\text{W} \times 16.5\text{mW} = 84.99^{\circ}\text{C} \quad (3)$$

For various application use cases, current consumption for other modules may have to be added to calculate the appropriate power dissipation. For example, the MCU may run simultaneously as the radio, peripheral modules may be enabled, and so on. Typically, the easiest way to find the peak current consumption, and thus the peak power dissipation in the device, is to measure as described in the [Measuring CC13xx and CC26xx Current Consumption](#) application report.

## 10 Device and Documentation Support

TI offers an extensive line of development tools. Tools and software to evaluate the performance of the device, generate code, and develop solutions are listed as follows.

### 10.1 Device Nomenclature

To designate the stages in the product development cycle, TI assigns prefixes to all part numbers and/or date-code. Each device has one of three prefixes/identifications: X, P, or null (no prefix) (for example, X is in preview; therefore, an X prefix/identification is assigned).

Device development evolutionary flow:

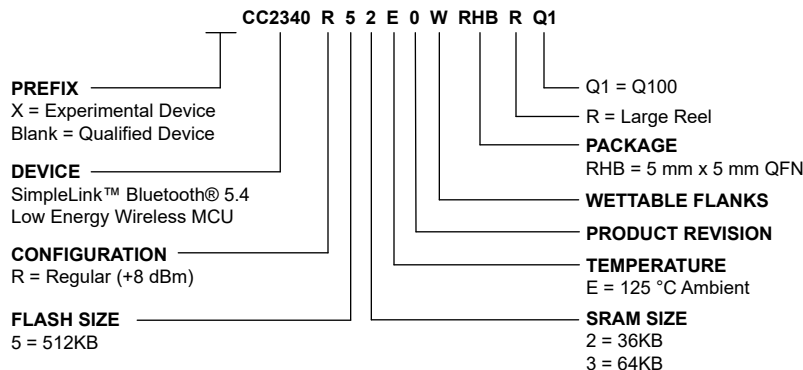
- X** Experimental device that is not necessarily representative of the final device's electrical specifications and may not use production assembly flow.
- P** Prototype device that is not necessarily the final silicon die and may not necessarily meet final electrical specifications.
- null** Production version of the silicon die that is fully qualified.

Production devices have been characterized fully, and the quality and reliability of the device have been demonstrated fully. TI's standard warranty applies.

Predictions show that prototype devices (X or P) have a greater failure rate than the standard production devices. Texas Instruments recommends that these devices not be used in any production system because their expected end-use failure rate is still undefined. Only qualified production devices are to be used.

TI device nomenclature also includes a suffix with the device family name. This suffix indicates the package type (for example, *RHB*).

For orderable part numbers of devices in the RHB (5mm × 5mm) package type, see the *Package Option Addendum* of this document, the Device Information in [Section 3](#), the TI website ([www.ti.com](http://www.ti.com)), or contact your TI sales representative.



**Figure 10-1. Device Nomenclature**

### 10.2 Tools and Software

The CC2340R5-Q1 device is supported by a variety of software and hardware development tools.

#### Development Kit

[CC2340R5  
LaunchPad™  
Development Kit](#)

The CC2340R5 LaunchPad™ Development Kit enables development of high-performance wireless applications that benefit from low-power operation. The kit features the CC2340R5 SimpleLink Wireless MCU, which allows you to quickly evaluate and prototype 2.4GHz wireless applications such as Bluetooth 5 Low Energy, Zigbee, and Thread, plus

combinations of these. The kit works with the LaunchPad ecosystem, easily enabling additional functionality like sensors, display, and more.

## Software

### SimpleLink™ CC23xx software development kit (SDK)

The SimpleLink CC23xx software development kit (SDK) provides a complete package for the development of wireless applications on the CC23xx family of devices. The SDK includes a comprehensive software package for the CC2340R5-Q1 device, including the following protocol stacks:

- Bluetooth Low Energy 5.4

The SimpleLink CC23xx SDK is part of TI's SimpleLink MCU platform, offering a single development environment that delivers flexible hardware, software, and tool options for customers developing wired and wireless applications. For more information about the SimpleLink MCU Platform, visit <https://www.ti.com/simplelink>.

## Development Tools

### Code Composer Studio™ Integrated Development Environment (IDE)

Code Composer Studio is an integrated development environment (IDE) that supports TI's Microcontroller and Embedded Processors portfolio. Code Composer Studio comprises a suite of tools used to develop and debug embedded applications. It includes an optimizing C/C++ compiler, source code editor, project build environment, debugger, profiler, and many other features. The intuitive IDE provides a single user interface, taking you through each step of the application development flow. Familiar tools and interfaces allow users to get started faster than ever before. Code Composer Studio combines the advantages of the Eclipse® software framework with advanced embedded debug capabilities from TI, resulting in a compelling, feature-rich development environment for embedded developers.

CCS has support for all SimpleLink Wireless MCUs and includes support for EnergyTrace™ software (application energy usage profiling). A real-time object viewer plugin is available for TI-RTOS, part of the SimpleLink SDK.

Code Composer Studio is provided free of charge when used in conjunction with the XDS debuggers included on a LaunchPad Development Kit.

### Code Composer Studio™ Cloud IDE

Code Composer Studio (CCS) Cloud is a web-based IDE that allows you to create, edit, and build CCS and Energia™ projects. After you have successfully built your project, you can download and run on your connected LaunchPad. Basic debugging, including features like setting breakpoints and viewing variable values, is now supported with CCS Cloud.

### IAR Embedded Workbench® for Arm®

IAR Embedded Workbench® is a set of development tools for building and debugging embedded system applications using Assembler, C, and C++. It provides a completely integrated development environment that includes a project manager, editor, and build tools. IAR has support for all SimpleLink Wireless MCUs. It offers broad debugger support, including XDS110, IAR I-jet™, and Segger J-Link™. A real-time object viewer plugin is available for TI-RTOS, part of the SimpleLink SDK. IAR is also supported out of the box on most software examples provided as part of the SimpleLink SDK.

A 30-day evaluation or a 32KB size-limited version is available through [iar.com](http://iar.com).

### SmartRF™ Studio

SmartRF™ Studio is a Windows® application that can be used to evaluate and configure SimpleLink Wireless MCUs from Texas Instruments. The application will help designers of RF systems to easily evaluate the radio at an early stage in the design process. It is especially useful for generating configuration register values and for practical testing and debugging of the RF system. SmartRF Studio can be used either as a standalone

application or together with applicable evaluation boards or debug probes for the RF device. Features of the SmartRF Studio include:

- Link tests—send and receive packets between nodes
- Antenna and radiation tests—set the radio in continuous wave TX and RX states
- Export radio configuration code for use with the TI SimpleLink SDK RF driver
- Custom GPIO configuration for signaling and control of external switches

### CCS UniFlash

CCS UniFlash is a standalone tool used to program on-chip flash memory on TI MCUs. UniFlash has a GUI, command line, and scripting interface. CCS UniFlash is available free of charge.

## 10.2.1 SimpleLink™ Microcontroller Platform

The SimpleLink microcontroller platform sets a new standard for developers with the broadest portfolio of wired and wireless Arm® MCUs (System-on-Chip) in a single software development environment. Delivering flexible hardware, software and tool options for your IoT applications. Invest once in the SimpleLink software development kit and use throughout your entire portfolio. Learn more at [ti.com/simplelink](https://ti.com/simplelink).

## 10.3 Documentation Support

To receive notification of documentation updates on data sheets, errata, application notes, and similar, navigate to the device product folder ([CC2340R5-Q1](#)). In the upper right corner, click on *Alert me* to register and receive a weekly digest of any product information that has changed. For change details, review the revision history included in any revised document.

The current documentation that describes the MCU, related peripherals, and other technical collateral is listed as follows.

### TI Resource Explorer

[TI Resource Explorer](#) Software examples, libraries, executables, and documentation are available for your device and development board.

### Errata

#### [CC2340R5-Q1 Silicon Errata](#)

The silicon errata describes the known exceptions to the functional specifications for each silicon revision of the device and how to recognize a device revision.

### Application Reports

All application reports for the CC2340R5-Q1 device are found on the device product folder ([CC2340R5-Q1](#)).

### Technical Reference Manual (TRM)

#### [CC23xx SimpleLink Wireless MCU Technical Reference Manual](#)

The TRM provides a detailed description of all modules and peripherals available in the device family.

## 10.4 Support Resources

[TI E2E™ support forums](#) are an engineer's go-to source for fast, verified answers and design help — straight from the experts. Search existing answers or ask your own question to get the quick design help you need.

Linked content is provided "AS IS" by the respective contributors. They do not constitute TI specifications and do not necessarily reflect TI's views; see TI's [Terms of Use](#).

## 10.5 Trademarks

SimpleLink™, LaunchPad™, Code Composer Studio™, EnergyTrace™, and TI E2E™ are trademarks of Texas Instruments.

™ is a trademark of TI.  
 I-jet™ is a trademark of IAR Systems AB.  
 J-Link™ is a trademark of SEGGER Microcontroller Systeme GmbH.  
 Arm® and Cortex® are registered trademarks of Arm Limited (or its subsidiaries) in the US and/or elsewhere.  
 Bluetooth® is a registered trademark of Bluetooth SIG.  
 CoreMark® is a registered trademark of Embedded Microprocessor Benchmark Consortium Corporation.  
 Eclipse® is a registered trademark of Eclipse Foundation.  
 IAR Embedded Workbench® is a registered trademark of IAR Systems AB.  
 Windows® is a registered trademark of Microsoft Corporation.  
 is a registered trademark of Arm Limited.  
 All trademarks are the property of their respective owners.

## 10.6 Electrostatic Discharge Caution



This integrated circuit can be damaged by ESD. Texas Instruments recommends that all integrated circuits be handled with appropriate precautions. Failure to observe proper handling and installation procedures can cause damage.

ESD damage can range from subtle performance degradation to complete device failure. Precision integrated circuits may be more susceptible to damage because very small parametric changes could cause the device not to meet its published specifications.

## 10.7 Glossary

[TI Glossary](#) This glossary lists and explains terms, acronyms, and definitions.

## 11 Revision History

NOTE: Page numbers for previous revisions may differ from page numbers in the current version.

### Changes from December 4, 2023 to July 31, 2025 (from Revision \* (December 2023) to Revision A (July 2025))

	Page
• Updated RAM, Bluetooth specifications, cybersecurity compliance, and the ESD classification.....	1
• Included CC2340R53E0WRHBRQ1 device and updated Bluetooth Spec.....	2
• Updated SRAM in the block diagram and added thermal shutdown note.....	3
• Added CC2340R53-Q1 and removed unnecessary parameters and parts from the table. Also, added the thermal shutdown column.....	5
• Update SPI Signal Names to PICO and POCI and DTB assignments.....	8
• Updated DTB pin assignments.....	12
• Updated test condition for standby current consumption with DCDC.....	19
• Updated test condition for standby current consumption with GLDO.....	19
• Changed "Frequency error tolerance" for 125kbps BLE PHY.....	21
• Changed "Frequency error tolerance" for 500kbps BLE PHY.....	21
• Changed "Frequency error tolerance" for 1Mbps BLE PHY.....	21
• Updated table note (6) for better clarity.....	21
• Changed "Frequency error tolerance" for 2Mbps BLE PHY.....	21
• Removed incorrect table note under LFOOSC table.....	25
• Changed min spec of SPI controller chip select lead time.....	26
• Changed min spec of SPI controller chip select lag time.....	26
• Changed min spec of SPI peripheral chip select lead time.....	27
• Changed min spec of SPI peripheral chip select lag time.....	27
• Updated Bluetooth Spec Version.....	42
• Updated RAM size.....	42
• Corrected T <sub>case</sub> temperature calculation example.....	49
• Updated Bluetooth Spec Version in figure.....	50
• Updated Bluetooth Spec Version.....	50
• Included device product folder link for CC2340R5-Q1.....	52

## 12 Mechanical, Packaging, and Orderable Information

The following pages include mechanical packaging and orderable information. This information is the most current data available for the designated devices. This data is subject to change without notice and revision of this document. For browser-based versions of this data sheet, refer to the left-hand navigation.

**PACKAGING INFORMATION**

Orderable part number	Status (1)	Material type (2)	Package   Pins	Package qty   Carrier	RoHS (3)	Lead finish/ Ball material (4)	MSL rating/ Peak reflow (5)	Op temp (°C)	Part marking (6)
<a href="#">CC2340R52E0WRHBRQ1</a>	Active	Production	VQFN (RHB)   32	5000   LARGE T&R	Yes	NIPDAU	Level-3-260C-168 HR	-40 to 125	CC2340Q R52
CC2340R52E0WRHBRQ1.A	Active	Production	VQFN (RHB)   32	5000   LARGE T&R	Yes	NIPDAU	Level-3-260C-168 HR	-40 to 125	CC2340Q R52
CC2340R52E0WRHBRQ1.B	Active	Production	VQFN (RHB)   32	5000   LARGE T&R	Yes	NIPDAU	Level-3-260C-168 HR	-40 to 125	CC2340Q R52
<a href="#">CC2340R53E0WRHBRQ1</a>	Active	Production	VQFN (RHB)   32	5000   LARGE T&R	Yes	NIPDAU	Level-3-260C-168 HR	-40 to 125	CC2340Q R53

(1) **Status:** For more details on status, see our [product life cycle](#).

(2) **Material type:** When designated, preproduction parts are prototypes/experimental devices, and are not yet approved or released for full production. Testing and final process, including without limitation quality assurance, reliability performance testing, and/or process qualification, may not yet be complete, and this item is subject to further changes or possible discontinuation. If available for ordering, purchases will be subject to an additional waiver at checkout, and are intended for early internal evaluation purposes only. These items are sold without warranties of any kind.

(3) **RoHS values:** Yes, No, RoHS Exempt. See the [TI RoHS Statement](#) for additional information and value definition.

(4) **Lead finish/Ball material:** Parts may have multiple material finish options. Finish options are separated by a vertical ruled line. Lead finish/Ball material values may wrap to two lines if the finish value exceeds the maximum column width.

(5) **MSL rating/Peak reflow:** The moisture sensitivity level ratings and peak solder (reflow) temperatures. In the event that a part has multiple moisture sensitivity ratings, only the lowest level per JEDEC standards is shown. Refer to the shipping label for the actual reflow temperature that will be used to mount the part to the printed circuit board.

(6) **Part marking:** There may be an additional marking, which relates to the logo, the lot trace code information, or the environmental category of the part.

Multiple part markings will be inside parentheses. Only one part marking contained in parentheses and separated by a "-" will appear on a part. If a line is indented then it is a continuation of the previous line and the two combined represent the entire part marking for that device.

**Important Information and Disclaimer:** The information provided on this page represents TI's knowledge and belief as of the date that it is provided. TI bases its knowledge and belief on information provided by third parties, and makes no representation or warranty as to the accuracy of such information. Efforts are underway to better integrate information from third parties. TI has taken and continues to take reasonable steps to provide representative and accurate information but may not have conducted destructive testing or chemical analysis on incoming materials and chemicals. TI and TI suppliers consider certain information to be proprietary, and thus CAS numbers and other limited information may not be available for release.

In no event shall TI's liability arising out of such information exceed the total purchase price of the TI part(s) at issue in this document sold by TI to Customer on an annual basis.

**OTHER QUALIFIED VERSIONS OF CC2340R5-Q1 :**

- Catalog : [CC2340R5](#)

## NOTE: Qualified Version Definitions:

- Catalog - TI's standard catalog product

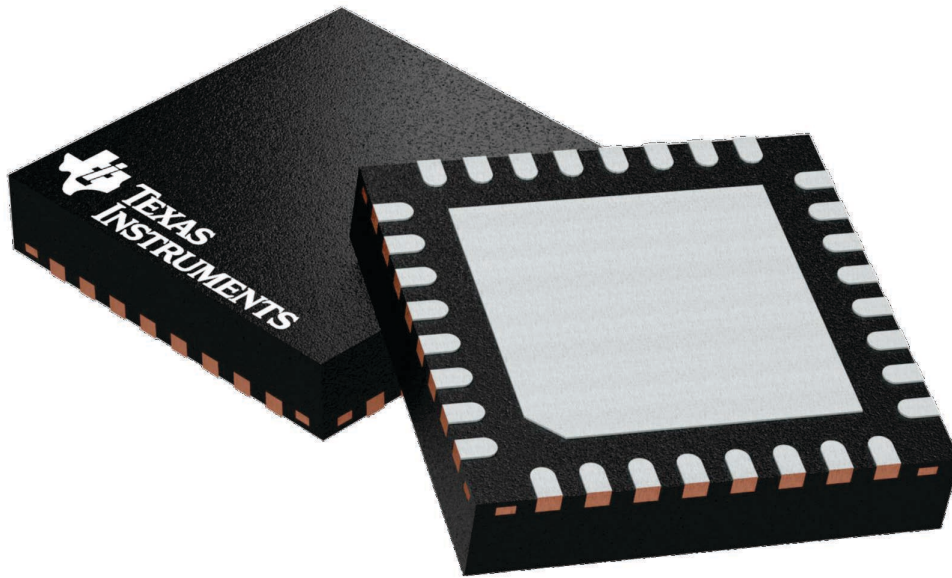
## GENERIC PACKAGE VIEW

**RHB 32**

**VQFN - 1 mm max height**

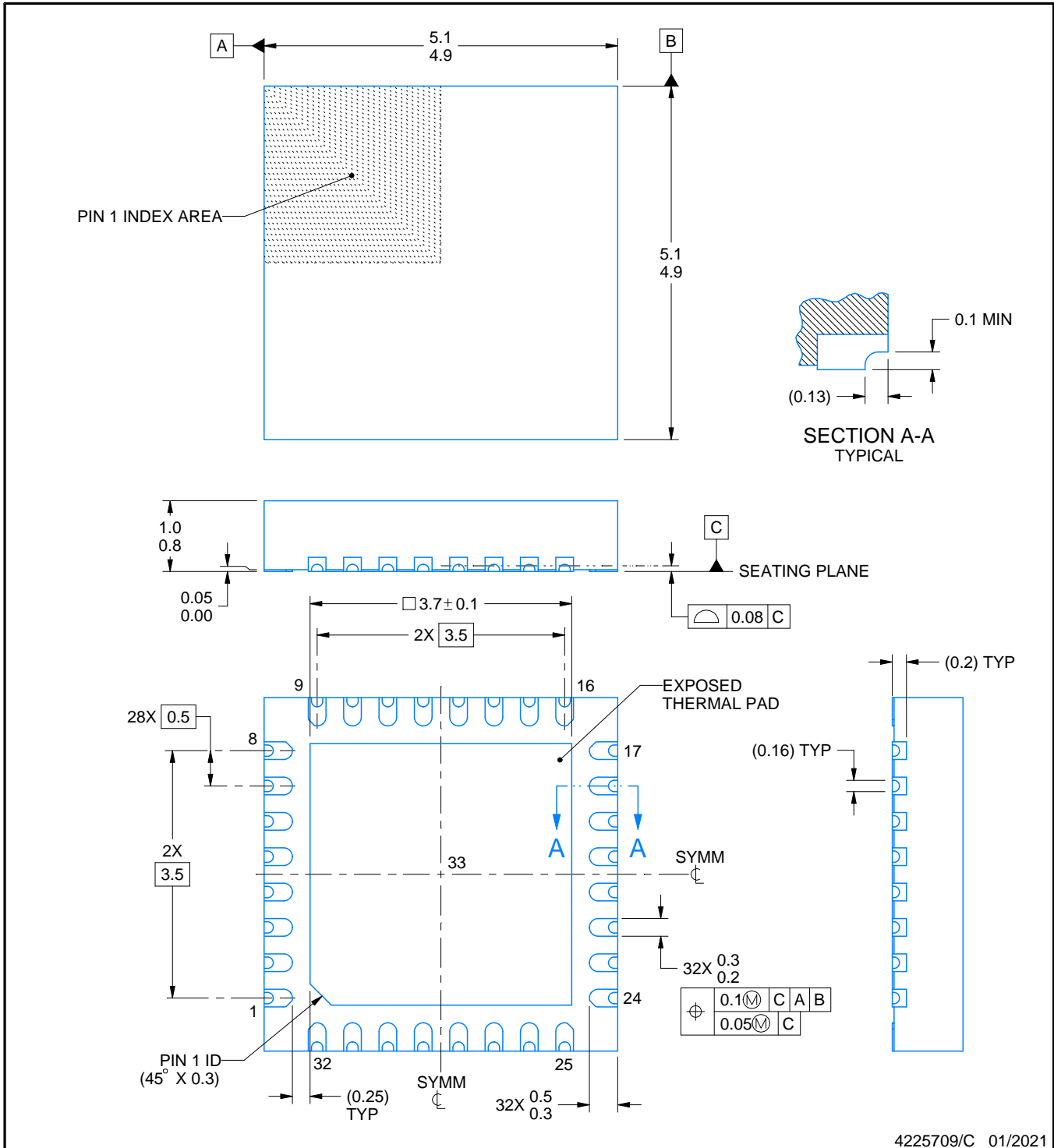
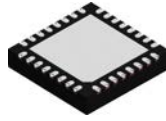
5 x 5, 0.5 mm pitch

PLASTIC QUAD FLATPACK - NO LEAD



Images above are just a representation of the package family, actual package may vary.  
Refer to the product data sheet for package details.

4224745/A



4225709/C 01/2021

NOTES:

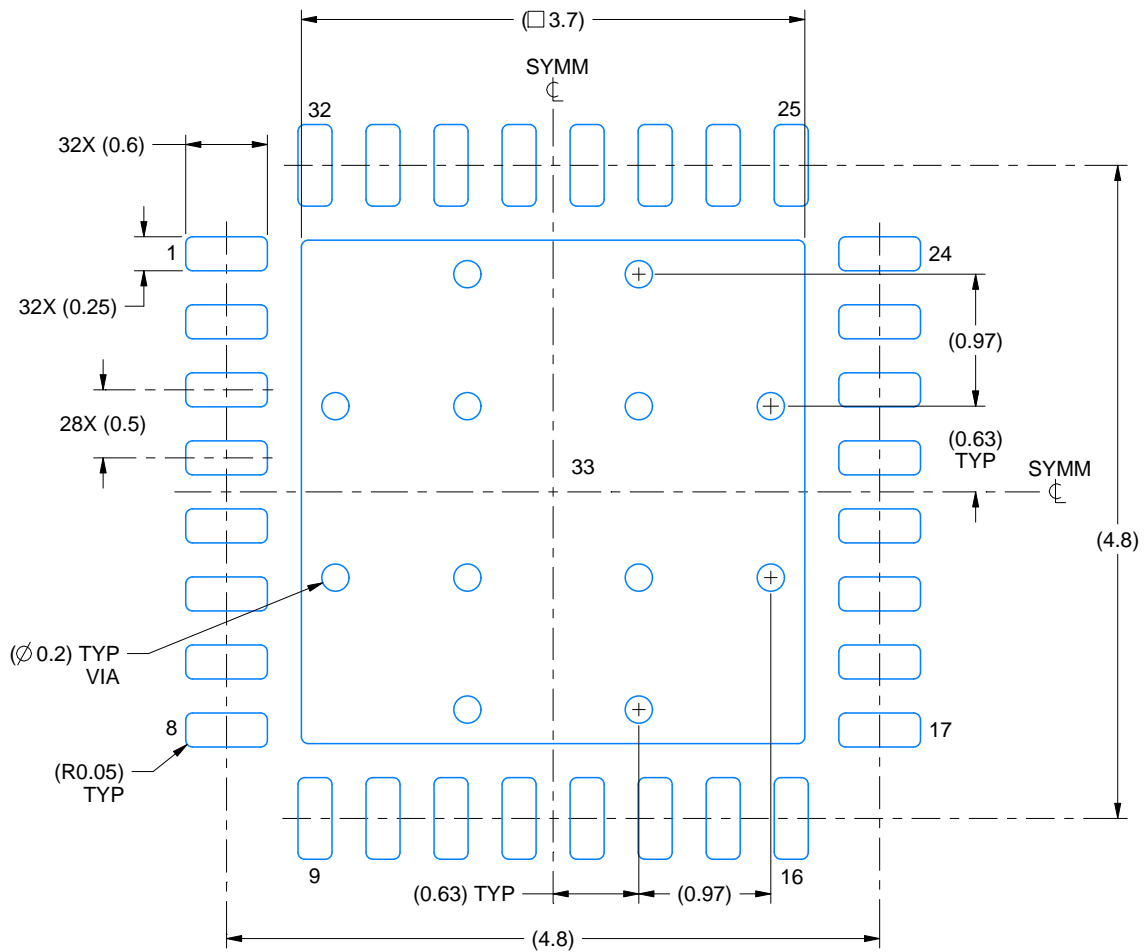
1. All linear dimensions are in millimeters. Any dimensions in parenthesis are for reference only. Dimensioning and tolerancing per ASME Y14.5M.
2. This drawing is subject to change without notice.
3. The package thermal pad must be soldered to the printed circuit board for thermal and mechanical performance.

# EXAMPLE BOARD LAYOUT

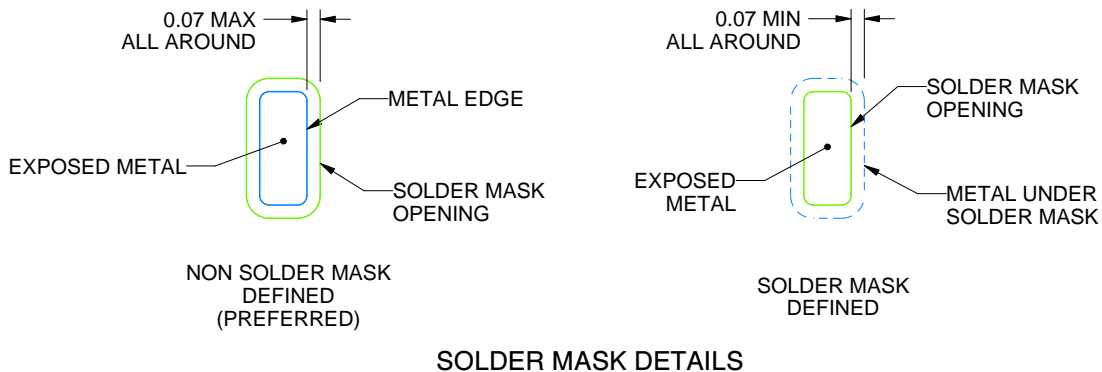
RHB0032U

VQFN - 1 mm max height

PLASTIC QUAD FLATPACK - NO LEAD



LAND PATTERN EXAMPLE  
EXPOSED METAL SHOWN  
SCALE:18X



SOLDER MASK DETAILS

4225709/C 01/2021

NOTES: (continued)

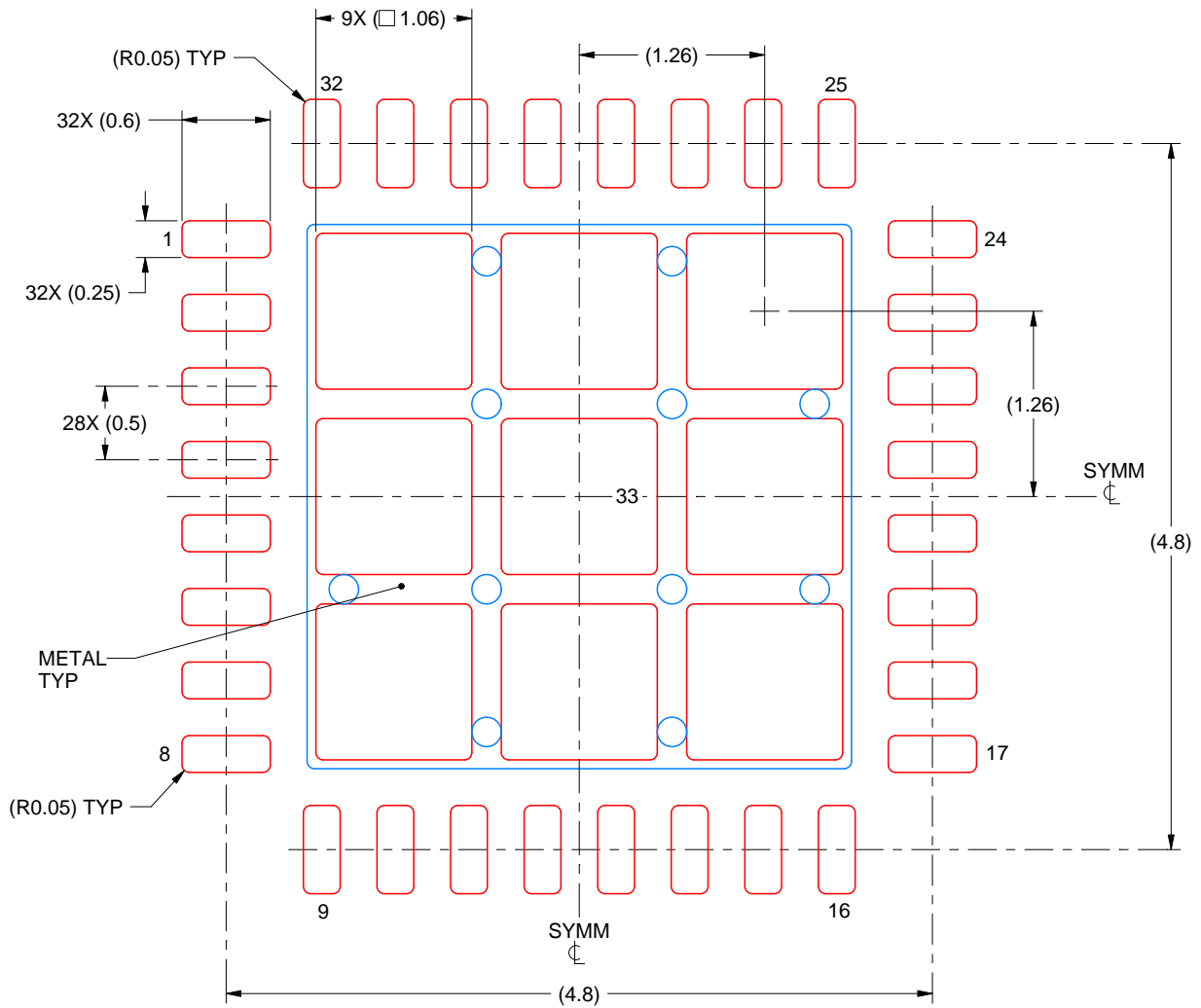
- This package is designed to be soldered to a thermal pad on the board. For more information, see Texas Instruments literature number SLUA271 ([www.ti.com/lit/slua271](http://www.ti.com/lit/slua271)).
- Vias are optional depending on application, refer to device data sheet. If any vias are implemented, refer to their locations shown on this view. It is recommended that vias under paste be filled, plugged or tented.

# EXAMPLE STENCIL DESIGN

RHB0032U

VQFN - 1 mm max height

PLASTIC QUAD FLATPACK - NO LEAD



**SOLDER PASTE EXAMPLE**  
 BASED ON 0.125 mm THICK STENCIL

EXPOSED PAD 33:  
 74% PRINTED SOLDER COVERAGE BY AREA UNDER PACKAGE  
 SCALE:20X

4225709/C 01/2021

NOTES: (continued)

6. Laser cutting apertures with trapezoidal walls and rounded corners may offer better paste release. IPC-7525 may have alternate design recommendations.

## IMPORTANT NOTICE AND DISCLAIMER

TI PROVIDES TECHNICAL AND RELIABILITY DATA (INCLUDING DATASHEETS), DESIGN RESOURCES (INCLUDING REFERENCE DESIGNS), APPLICATION OR OTHER DESIGN ADVICE, WEB TOOLS, SAFETY INFORMATION, AND OTHER RESOURCES "AS IS" AND WITH ALL FAULTS, AND DISCLAIMS ALL WARRANTIES, EXPRESS AND IMPLIED, INCLUDING WITHOUT LIMITATION ANY IMPLIED WARRANTIES OF MERCHANTABILITY, FITNESS FOR A PARTICULAR PURPOSE OR NON-INFRINGEMENT OF THIRD PARTY INTELLECTUAL PROPERTY RIGHTS.

These resources are intended for skilled developers designing with TI products. You are solely responsible for (1) selecting the appropriate TI products for your application, (2) designing, validating and testing your application, and (3) ensuring your application meets applicable standards, and any other safety, security, regulatory or other requirements.

These resources are subject to change without notice. TI grants you permission to use these resources only for development of an application that uses the TI products described in the resource. Other reproduction and display of these resources is prohibited. No license is granted to any other TI intellectual property right or to any third party intellectual property right. TI disclaims responsibility for, and you fully indemnify TI and its representatives against any claims, damages, costs, losses, and liabilities arising out of your use of these resources.

TI's products are provided subject to [TI's Terms of Sale](#), [TI's General Quality Guidelines](#), or other applicable terms available either on [ti.com](#) or provided in conjunction with such TI products. TI's provision of these resources does not expand or otherwise alter TI's applicable warranties or warranty disclaimers for TI products. Unless TI explicitly designates a product as custom or customer-specified, TI products are standard, catalog, general purpose devices.

TI objects to and rejects any additional or different terms you may propose.

Copyright © 2025, Texas Instruments Incorporated

Last updated 10/2025

## Looking for pricing, stock, or lifecycle information?

Click below to explore more details on WIN SOURCE:

 [View CC2340R52E0WRHBRQ1 on WIN SOURCE](#)

 [Texas Instruments](#) Information

## Optimize Your Supply Chain with WIN SOURCE Solutions

-  Global Sourcing Solution
-  Obsolete Management
-  Cost Control Management
-  Shortage Management
-  Alternative Solution
-  Excess Inventory Management