

ESP32-C3 Series

Datasheet Version 2.3

Ultra-Low-Power SoC with RISC-V Single-Core CPU
2.4 GHz Wi-Fi (802.11b/g/n) and Bluetooth® 5 (LE)
Optional flash in the chip's package up to 8 MB
QFN32 (5×5 mm) package

Including:

ESP32-C3

ESP32-C3FN4 – [End of life \(EOL\)](#)

ESP32-C3FH4

ESP32-C3FH4AZ – [Not Recommended for New Designs \(NRND\)](#)

ESP32-C3FH4X – Recommended

ESP32-C3FH8X – Sample



ESPRESSIF

Product Overview

ESP32-C3 is a low-power and highly-integrated MCU-based solution that supports 2.4 GHz Wi-Fi and Bluetooth® Low Energy (Bluetooth LE).

The functional block diagram of the SoC is shown below.

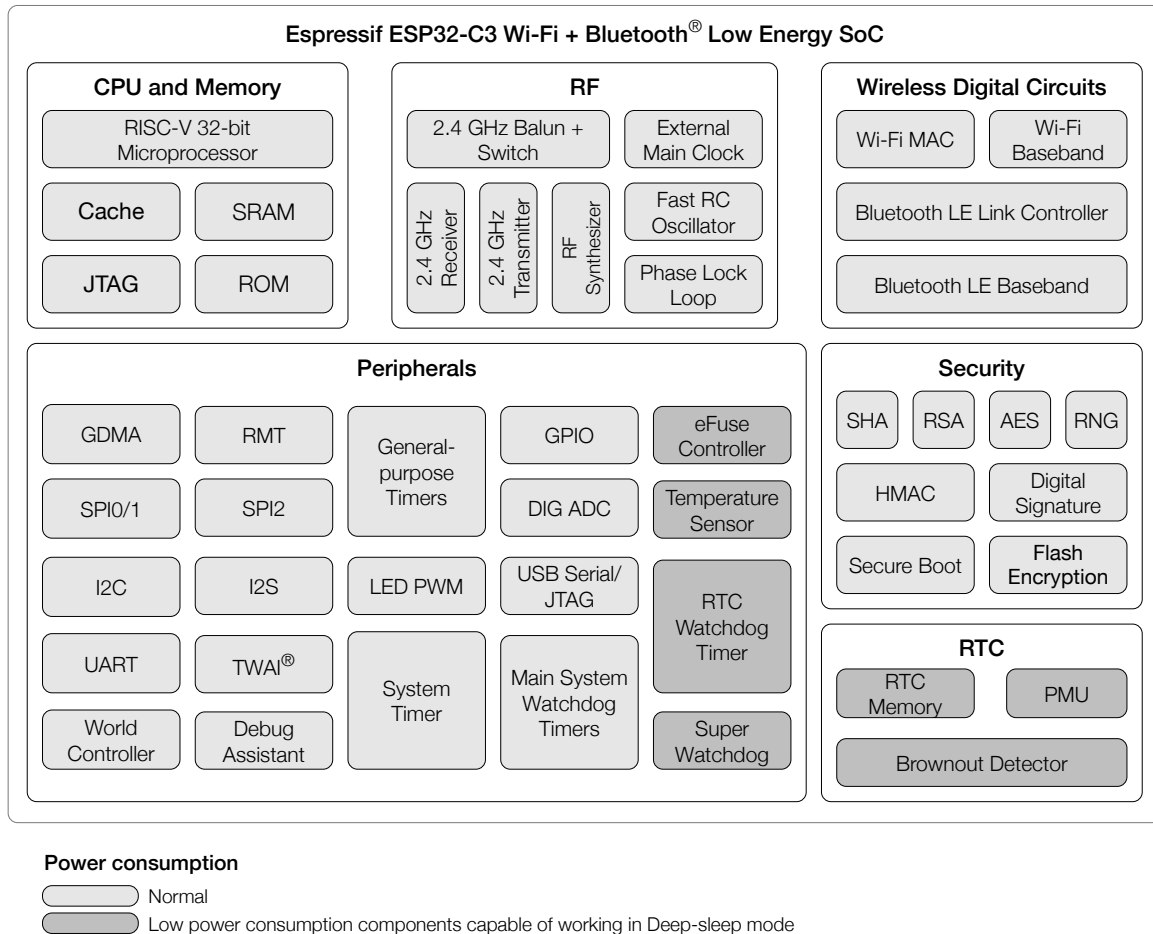

ESP32-C3 Functional Block Diagram

For more information on power consumption, see Section [4.1.3.6 Power Management Unit](#).

The ESP32-C3 [chip series](#) is a member of the ESP32-C3 [chip series group](#). For more information about this chip series group, see [ESP32-C3 Chip Series Group Overview](#).

Features

Wi-Fi

- Complies with IEEE 802.11b/g/n
- Supports 20 MHz and 40 MHz bandwidth in 2.4 GHz band
- 1T1R mode with data rate up to 150 Mbps
- Wi-Fi Multimedia (WMM)
- TX/RX A-MPDU, TX/RX A-MSDU
- Immediate Block ACK
- Fragmentation and defragmentation
- Transmit opportunity (TXOP)
- Automatic Beacon monitoring (hardware TSF)
- 4 × virtual Wi-Fi interfaces
- Simultaneous support for Infrastructure BSS in Station mode, SoftAP mode, Station + SoftAP mode, and promiscuous mode
Note that when ESP32-C3 scans in Station mode, the SoftAP channel will change along with the Station channel
- Antenna diversity
- 802.11mc FTM

Bluetooth®

- Bluetooth LE: Bluetooth 5, Bluetooth mesh
- High power mode with up to 20 dBm transmission power
- Speed: 125 Kbps, 500 Kbps, 1 Mbps, 2 Mbps
- Advertising extensions
- Multiple advertisement sets
- Channel selection algorithm #2
- Internal co-existence mechanism between Wi-Fi and Bluetooth to share the same antenna

CPU and Memory

- 32-bit RISC-V single-core processor
- Clock speed: up to 160 MHz
- CoreMark® score:
 - 1 core at 160 MHz: 483.27 CoreMark; 3.02 CoreMark/MHz
- General DMA controller (GDMA), with 3 transmit channels and 3 receive channels

- ROM: 384 KB
- SRAM: 400 KB (16 KB for cache)
- SRAM in RTC: 8 KB
- 4096-bit eFuse memory, up to 1792 bits for users
- [In-package flash](#) (see details in Chapter 1 *ESP32-C3 Series Comparison*)
- Supported SPI protocols: SPI, Dual SPI, Quad SPI, and QPI interfaces that allow connection to multiple [off-package flash](#) and other SPI devices
- Access to flash accelerated by cache
- Supports flash in-Circuit Programming (ICP)

Peripherals

- Programmable GPIOs
 - 22 for SP32-C3, ESP32-C3FH4, ESP32-C3FN4 and ESP32-C3FH8X
 - * 3 strapping GPIOs
 - * 6 GPIOs allocated for in-package flash
 - 16 for ESP32-C3FH4X and ESP32-C3FH4AZ
 - * 3 strapping GPIOs
- Connectivity interfaces:
 - Two UARTs
 - Three SPI
 - I2C
 - I2S
 - Full-speed USB Serial/JTAG controller
 - TWAI[®] controller compatible with ISO 11898-1 (CAN Specification 2.0)
 - LED PWM controller, with up to 6 channels
 - Remote control peripheral, with 2 transmit channels and 2 receive channels
- Analog signal processing:
 - Two 12-bit SAR ADCs, up to 6 channels
 - Temperature sensor
- Timers:
 - Two 54-bit general-purpose timers
 - Three digital watchdog timers
 - Analog watchdog timer
 - 52-bit system timer

- XTAL32K wachtog timer

Power Management

- Fine-resolution power control, including clock frequency, duty cycle, Wi-Fi operating modes, and individual internal component control
- Four power modes designed for typical scenarios: Active, Modem-sleep, Light-sleep, Deep-sleep
- Power consumption in Deep-sleep mode is 5 μ A
- RTC memory remains powered on in Deep-sleep mode

Security

- Secure boot - permission control on accessing internal and external memory
- Flash encryption - memory encryption and decryption
- Cryptographic hardware acceleration:
 - AES-128/256 (FIPS PUB 197)
 - SHA Accelerator (FIPS PUB 180-4)
 - RSA Accelerator
 - Random Number Generator (RNG)
 - HMAC
 - Digital signature
- Clock glitch detection

RF Module

- Antenna switches, RF balun, power amplifier, low-noise receive amplifier
- Up to +21 dBm of power for an 802.11b transmission
- Up to +20 dBm of power for an 802.11n transmission
- Up to -105 dBm of sensitivity for Bluetooth LE receiver (125 Kbps)

Applications

With low power consumption, ESP32-C3 is an ideal choice for IoT devices in the following areas:

- Smart Home
- Industrial Automation
- Health Care
- Consumer Electronics
- Smart Agriculture
- POS Machines
- Service Robot
- Audio Devices
- Generic Low-power IoT Sensor Hubs
- Generic Low-power IoT Data Loggers

Note:

Check the link or the QR code to make sure that you use the latest version of this document:
https://www.espressif.com/documentation/esp32-c3_datasheet_en.pdf



Contents

Product Overview	2
Features	3
Applications	5
1 ESP32-C3 Series Comparison	12
1.1 Nomenclature	12
1.2 Comparison	12
1.3 Chip Revision	13
2 Pins	14
2.1 Pin Layout	14
2.2 Pin Overview	16
2.3 IO Pins	19
2.3.1 IO MUX Functions	19
2.3.2 Analog Functions	21
2.3.3 Restrictions for GPIOs	22
2.3.4 Peripheral Pin Assignment	23
2.4 Analog Pins	25
2.5 Power Supply	26
2.5.1 Power Pins	26
2.5.2 Power Scheme	26
2.5.3 Chip Power-up and Reset	27
2.6 Pin Mapping Between Chip and Flash	29
3 Boot Configurations	30
3.1 Chip Boot Mode Control	31
3.2 ROM Messages Printing Control	31
4 Functional Description	33
4.1 System	33
4.1.1 Microprocessor and Master	33
4.1.1.1 High-Performance CPU	33
4.1.1.2 GDMA Controller	33
4.1.2 Memory Organization	33
4.1.2.1 Internal Memory	34
4.1.2.2 External Memory	35

4.1.2.3	Cache	35
4.1.2.4	eFuse Controller	35
4.1.3	System Components	36
4.1.3.1	IO MUX and GPIO Matrix	36
4.1.3.2	Reset	36
4.1.3.3	Clock	37
4.1.3.4	Interrupt Matrix	37
4.1.3.5	System Timer	38
4.1.3.6	Power Management Unit	38
4.1.3.7	Timer Group	40
4.1.3.8	Watchdog Timers	40
4.1.3.9	XTAL32K Watchdog Timers (XTWDT)	41
4.1.3.10	Permission Control	41
4.1.3.11	World Controller (WCL)	41
4.1.3.12	System Registers	42
4.1.3.13	Debug Assistant	42
4.1.4	Cryptography and Security Component	43
4.1.4.1	AES Accelerator	43
4.1.4.2	HMAC Accelerator	43
4.1.4.3	RSA Accelerator	44
4.1.4.4	SHA Accelerator	44
4.1.4.5	Digital Signature	44
4.1.4.6	External Memory Encryption and Decryption	45
4.1.4.7	Random Number Generator	45
4.1.4.8	Clock Glitch Detection	45
4.2	Peripherals	46
4.2.1	Connectivity Interface	46
4.2.1.1	UART Controller	46
4.2.1.2	SPI Controller	46
4.2.1.3	I2C Controller	47
4.2.1.4	I2S Controller	47
4.2.1.5	USB Serial/JTAG Controller	48
4.2.1.6	Two-wire Automotive Interface	48
4.2.1.7	LED PWM Controller	48
4.2.1.8	Remote Control Peripheral	49
4.2.2	Analog Signal Processing	49
4.2.2.1	SAR ADC	49
4.2.2.2	Temperature Sensor	50
4.3	Wireless Communication	51
4.3.1	Radio	51
4.3.1.1	2.4 GHz Receiver	51
4.3.1.2	2.4 GHz Transmitter	51
4.3.1.3	Clock Generator	51
4.3.2	Wi-Fi	52
4.3.2.1	Wi-Fi Radio and Baseband	52
4.3.2.2	Wi-Fi MAC	52

4.3.2.3	Networking Features	53
4.3.3	Bluetooth LE	53
4.3.3.1	Bluetooth LE PHY	53
4.3.3.2	Bluetooth LE Link Controller	53
5	Electrical Characteristics	54
5.1	Absolute Maximum Ratings	54
5.2	Recommended Operating Conditions	54
5.3	VDD_SPI Output Characteristics	55
5.4	DC Characteristics (3.3 V, 25 °C)	55
5.5	ADC Characteristics	56
5.6	Current Consumption	56
5.6.1	RF Current Consumption in Active Mode	56
5.6.2	Current Consumption in Other Modes	57
5.7	Memory Specifications	57
5.8	Reliability	58
6	RF Characteristics	59
6.1	Wi-Fi Radio	59
6.1.1	Wi-Fi RF Transmitter (TX) Characteristics	59
6.1.2	Wi-Fi RF Receiver (RX) Characteristics	60
6.2	Bluetooth 5 (LE) Radio	61
6.2.1	Bluetooth LE RF Transmitter (TX) Characteristics	61
6.2.2	Bluetooth LE RF Receiver (RX) Characteristics	63
7	Packaging	66
	ESP32-C3 Consolidated Pin Overview	67
	ESP32-C3 Chip Series Group Overview	68
	Datasheet Versioning	69
	Glossary	70
	Related Documentation and Resources	71
	Revision History	72

List of Tables

1-1	ESP32-C3 Series Comparison	12
2-1	Pin Overview	16
2-2	Power-Up Glitches on Pins	18
2-3	Peripheral Signals Routed via IO MUX	19
2-4	IO MUX Pin Functions	19
2-5	Analog Signals Routed to Analog Functions	21
2-6	Analog Functions	21
2-7	Peripheral Pin Assignment	24
2-8	Analog Pins	25
2-9	Power Pins	26
2-10	Voltage Regulators	26
2-11	Description of Timing Parameters for Power-up and Reset	28
2-12	Pin Mapping Between Chip and In-package Flash	29
3-1	Default Configuration of Strapping Pins	30
3-2	Description of Timing Parameters for the Strapping Pins	30
3-3	Chip Boot Mode Control	31
3-4	UART0 ROM Message Printing Control	32
3-5	USB Serial/JTAG ROM Message Printing Control	32
4-1	Components and Power Domains	39
5-1	Absolute Maximum Ratings	54
5-2	Recommended Operating Conditions	54
5-3	VDD_SPI Internal and Output Characteristics	55
5-4	DC Characteristics (3.3 V, 25 °C)	55
5-5	ADC Characteristics	56
5-6	ADC Calibration Results	56
5-7	Wi-Fi Current Consumption Depending on RF Modes	56
5-8	Current Consumption in Modem-sleep Mode	57
5-9	Current Consumption in Low-Power Modes	57
5-10	Flash Specifications	57
5-11	Reliability Qualifications	58
6-1	Wi-Fi Frequency	59
6-2	TX Power with Spectral Mask and EVM Meeting 802.11 Standards	59
6-3	TX EVM Test	59
6-4	RX Sensitivity	60
6-5	Maximum RX Level	61
6-6	RX Adjacent Channel Rejection	61
6-7	Bluetooth LE Frequency	61
6-8	Transmitter Characteristics - Bluetooth LE 1 Mbps	61
6-9	Transmitter Characteristics - Bluetooth LE 2 Mbps	62
6-10	Transmitter Characteristics - Bluetooth LE 125 Kbps	62
6-11	Transmitter Characteristics - Bluetooth LE 500 Kbps	63
6-12	Receiver Characteristics - Bluetooth LE 1 Mbps	63
6-13	Receiver Characteristics - Bluetooth LE 2 Mbps	64

6-14 Receiver Characteristics - Bluetooth LE 125 Kbps	64
6-15 Receiver Characteristics - Bluetooth LE 500 Kbps	65

List of Figures

1-1	ESP32-C3 Series Nomenclature	12
2-1	Pin Layout (Top View) for ESP32-C3, ESP32-C3FH4, ESP32-C3FN4, and ESP32-C3FH8X	14
2-2	Pin Layout (Top View) for ESP32-C3FH4X and ESP32-C3FH4AZ	15
2-3	ESP32-C3 Power Scheme	27
2-4	Visualization of Timing Parameters for Power-up and Reset	27
3-1	Visualization of Timing Parameters for the Strapping Pins	31
4-1	Address Mapping Structure	34
4-2	Components and Power Domains	39
7-1	QFN32 (5×5 mm) Package	66

1 ESP32-C3 Series Comparison

1.1 Nomenclature

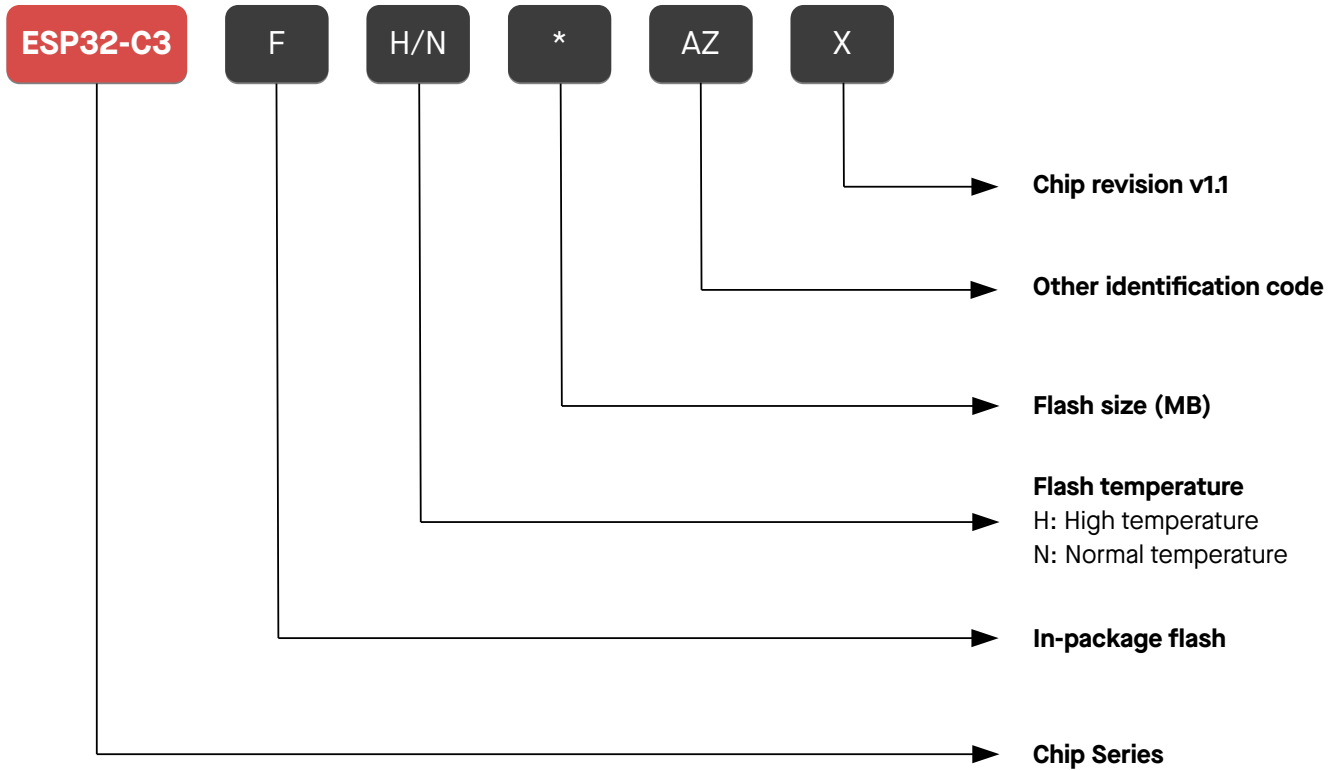

Figure 1-1. ESP32-C3 Series Nomenclature

1.2 Comparison

Table 1-1. ESP32-C3 Series Comparison

Part Number ¹	In-Package Flash ³	Ambient Temp. ² (°C)	Package (mm)	GPIO No. ⁶	Chip Revision ⁴
ESP32-C3 ⁵	—	−40 ~ 105	QFN32 (5*5)	22	v0.4
ESP32-C3FN4 (EOL)	4 MB	−40 ~ 85	QFN32 (5*5)	22	v0.4
ESP32-C3FH4	4 MB	−40 ~ 105	QFN32 (5*5)	22	v0.4
ESP32-C3FH4AZ (NRND)	4 MB	−40 ~ 105	QFN32 (5*5)	16	v0.4
ESP32-C3FH4X (Recommended)	4 MB	−40 ~ 105	QFN32 (5*5)	16	v1.1
ESP32-C3FH8X (Sample)	8 MB	−40 ~ 105	QFN32 (5*5)	22	v1.1

- ¹ For details on chip marking and packing, see Section [7 Packaging](#).
- ² Ambient temperature specifies the recommended temperature range of the environment immediately outside an Espressif chip.
- ³ For information about in-package flash, see also Section [4.1.2.1 Internal Memory](#). By default, the SPI flash on the chip operates at a maximum clock frequency of 80 MHz and does not support the auto suspend feature. If you have a requirement for a higher flash clock frequency of 120 MHz or if you need the flash auto suspend feature, please contact us.
- ⁴ All chip revisions have the same SRAM size, but chip revision v1.1 has around 10 KB more available space for users than chip revision v0.4. Chip revision v1.1 depends on specific ESP-IDF versions, as detailed in [Compatibility Advisory for ESP32-C3 Chip Revision v1.1](#). For how to identify chip revisions, please refer to [ESP32-C3 Series SoC Errata](#).
- ⁵ ESP32-C3 requires an SPI flash off the chip's package. For details about SPI modes, see Section [2.6 Pin Mapping Between Chip and Flash](#).
- ⁶ SPIO/SPI1 pins for flash connection are not bonded for variants with 16 GPIOs.

1.3 Chip Revision

As shown in Table [1-1 ESP32-C3 Series Comparison](#), ESP32-C3 now has multiple chip revisions available on the market.

For chip revision identification, ESP-IDF release that supports a specific chip revision, and errors fixed in each chip revision, please refer to [ESP32-C3 Series SoC Errata](#).

2 Pins

2.1 Pin Layout

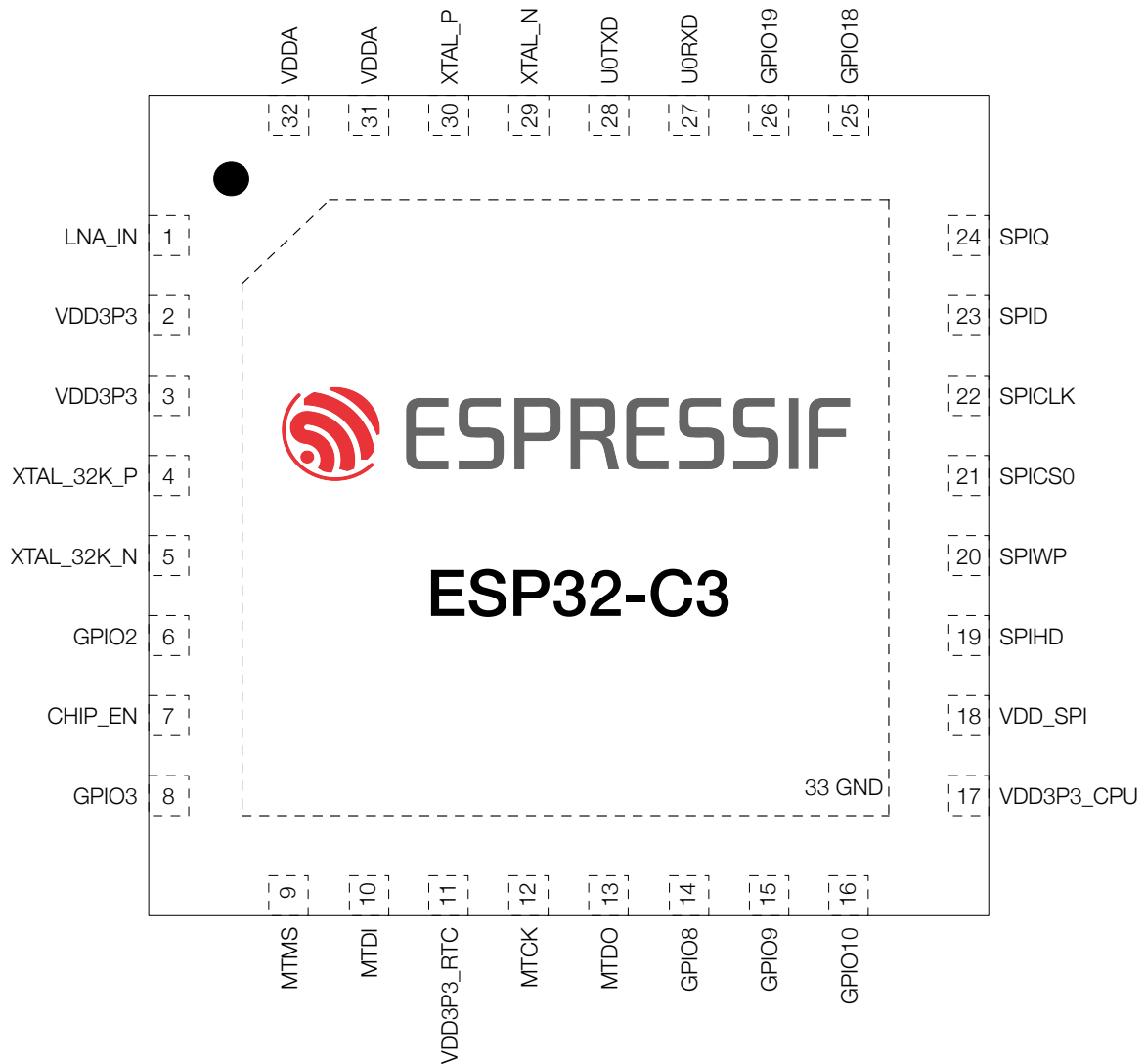

Figure 2-1. Pin Layout (Top View) for ESP32-C3, ESP32-C3FH4, ESP32-C3FN4, and ESP32-C3FH8X

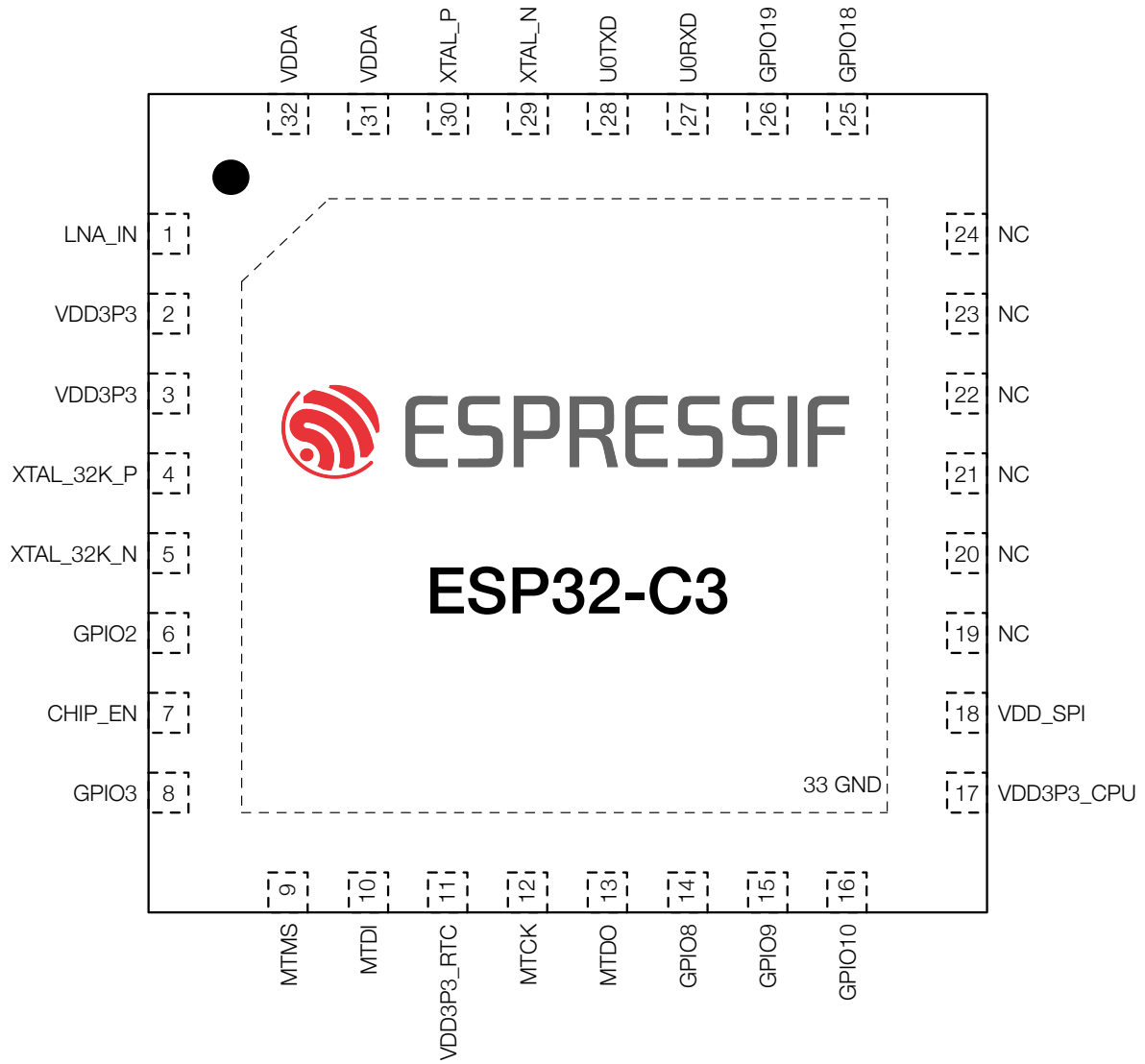

Figure 2-2. Pin Layout (Top View) for ESP32-C3FH4X and ESP32-C3FH4AZ

2.2 Pin Overview

The ESP32-C3 chip integrates multiple peripherals that require communication with the outside world. To keep the chip package size reasonably small, the number of available pins has to be limited. So the only way to route all the incoming and outgoing signals is through pin multiplexing. Pin muxing is controlled via software programmable registers (see [ESP32-C3 Technical Reference Manual](#) > Chapter *IO MUX and GPIO Matrix*).

All in all, the ESP32-C3 chip has the following types of pins:

- **IO pins** with the following predefined sets of functions to choose from:
 - Each IO pin has predefined **IO MUX functions** – see Table [2-4 IO MUX Pin Functions](#)
 - Some IO pins have predefined **analog functions** – see Table [2-6 Analog Functions](#)

Predefined functions means that each IO pin has a set of direct connections to certain signals from on-chip [peripherals](#). During run-time, the user can configure which peripheral signal from a predefined set to connect to a certain pin at a certain time via memory mapped registers.
- **Analog pins** that have exclusively-dedicated **analog functions** – see Table [2-8 Analog Pins](#)
- **Power pins** that supply power to the chip components and non-power pins – see Table [2-9 Power Pins](#)

Table [2-1 Pin Overview](#) gives an overview of all the pins. For more information, see the respective sections for each pin type below, or [ESP32-C3 Consolidated Pin Overview](#).

Table 2-1. Pin Overview

Pin No.	Pin Name	Pin Type	Pin Providing Power ²⁻⁴	Pin Settings ⁵		Pin Function Sets ¹	
				At Reset	After Reset	IO MUX	Analog
1	LNA_IN	Analog					
2	VDD3P3	Power					
3	VDD3P3	Power					
4	XTAL_32K_P	IO	VDD3P3_RTC			IO MUX	Analog
5	XTAL_32K_N	IO	VDD3P3_RTC			IO MUX	Analog
6	GPIO2	IO	VDD3P3_RTC	IE	IE	IO MUX	Analog
7	CHIP_EN	Analog					
8	GPIO3	IO	VDD3P3_RTC	IE	IE	IO MUX	Analog
9	MTMS	IO	VDD3P3_RTC		IE	IO MUX	Analog
10	MTDI	IO	VDD3P3_RTC		IE	IO MUX	Analog
11	VDD3P3_RTC	Power					
12	MTCK	IO	VDD3P3_CPU		IE ⁶	IO MUX	
13	MTDO	IO	VDD3P3_CPU		IE	IO MUX	
14	GPIO8	IO	VDD3P3_CPU	IE	IE	IO MUX	
15	GPIO9	IO	VDD3P3_CPU	IE, WPU	IE, WPU	IO MUX	
16	GPIO10	IO	VDD3P3_CPU		IE	IO MUX	
17	VDD3P3_CPU	Power					
18	VDD_SPI ⁸	Power	VDD3P3_CPU			IO MUX	
19	SPIHD	IO	VDD_SPI / VDD3P3_CPU	WPU	IE, WPU	IO MUX	
20	SPIWP	IO	VDD_SPI / VDD3P3_CPU	WPU	IE, WPU	IO MUX	

Cont'd on next page

Table 2-1 – cont'd from previous page

Pin No.	Pin Name ⁹	Pin Type	Pin Providing Power ²⁻⁴	Pin Settings ⁵		Pin Function Sets ¹	
				At Reset	After Reset	IO MUX	Analog
21	SPICSO	IO	VDD_SPI / VDD3P3_CPU	WPU	IE, WPU	IO MUX	
22	SPICLK	IO	VDD_SPI / VDD3P3_CPU	WPU	IE, WPU	IO MUX	
23	SPID	IO	VDD_SPI / VDD3P3_CPU	WPU	IE, WPU	IO MUX	
24	SPIQ	IO	VDD_SPI / VDD3P3_CPU	WPU	IE, WPU	IO MUX	
25	GPIO18	IO	VDD3P3_CPU			IO MUX	Analog
26	GPIO19	IO	VDD3P3_CPU		USB_PU	IO MUX	Analog
27	U0RXD	IO	VDD3P3_CPU		IE, WPU	IO MUX	
28	U0TXD	IO	VDD3P3_CPU		WPU ⁷	IO MUX	
29	XTAL_N	Analog					
30	XTAL_P	Analog					
31	VDDA	Power					
32	VDDA	Power					
33	GND	Power					

- 1.** **Bold** marks the pin function set in which a pin has its default function in the default boot mode. See Section [3.1 Chip Boot Mode Control](#).
- In column **Pin Providing Power**, regarding pins powered by VDD_SPI:
 - Power actually comes from the internal power rail supplying power to VDD_SPI. For details, see Section [2.5.2 Power Scheme](#).
- In column **Pin Providing Power**, regarding pins powered by VDD3P3_CPU / VDD_SPI:
 - Pin Providing Power (either VDD3P3_CPU or VDD_SPI) can be configured via a register, see [ESP32-C3 Technical Reference Manual](#) > Chapter *IO MUX and GPIO Matrix*.
- The default drive strength for each pin is as follows:
 - GPIO2, GPIO3, MTMS, and MTDI: 10 mA
 - GPIO18, GPIO19: 40 mA
 - All other pins: 20 mA
- Column **Pin Settings** shows predefined settings at reset and after reset with the following abbreviations:
 - IE – input enabled
 - WPU – internal weak pull-up resistor enabled
 - WPD – internal weak pull-down resistor enabled
 - USB_PU – USB pull-up resistor enabled
 - By default, the USB function is enabled for USB pins (i.e., GPIO18 and GPIO19), and the pin pull-up is decided by the USB pull-up resistor. The USB pull-up resistor is controlled by USB_SERIAL_JTAG_DP/DM_PULLUP and the pull-up value is controlled by USB_SERIAL_JTAG_PULLUP_VALUE. For details, see [ESP32-C3 Technical Reference Manual](#) > Chapter *USB Serial/JTAG Controller*.
 - When the USB function is disabled, USB pins are used as regular GPIOs and the pin's internal weak pull-up and pull-down resistors are disabled by default (configurable by IO_MUX_FUN_WPU/WPD). For details, see [ESP32-C3 Technical Reference Manual](#) > Chapter *IO MUX and GPIO Matrix*.
- Depends on the value of EFUSE_DIS_PAD_JTAG
 - 0 - default value. Input enabled, and internal weak pull-up resistor enabled (IE & WPU)
 - 1 - input enabled (IE)
- Output enabled
- By default VDD_SPI is the power supply pin for in-package and off-package flash. It can be reconfigured as a GPIO pin, if the chip is connected to an off-package flash, and this flash is powered by an external power supply. For details about reconfiguration, please refer to [ESP32-C3 Technical Reference Manual](#) > Chapter *IO MUX and GPIO Matrix*.
- For ESP32-C3FH4AZ and ESP32-C3FH4X, pins within the frame (namely pin 19 ~ pin 24) are not bonded, and are labelled as "not connected (NC)".

Some pins have glitches during power-up. See details in Table 2-2.

Table 2-2. Power-Up Glitches on Pins

Pin	Glitch ¹	Typical Time Period(ns)
MTCK	Low-level glitch	5
MTDO	Low-level glitch	5
GPIO10	Low-level glitch	5
UORXD	Low-level glitch	5
GPIO18	High-level glitch	50000

¹ Low-level glitch: the pin is at a low level output status during the time period;

High-level glitch: the pin is at a high level output status during the time period;

Pull-down glitch: the pin is at an internal weak pulled-down status during the time period;

Pull-up glitch: the pin is at an internal weak pulled-up status during the time period.

Please refer to Table 5-4 for detailed parameters about low/high-level and pull-down/up.

2.3 IO Pins

2.3.1 IO MUX Functions

The IO MUX allows multiple input/output signals to be connected to a single input/output pin. Each IO pin of ESP32-C3 can be connected to one of the three signals (IO MUX functions, i.e., FO-F2), as listed in Table 2-4 *IO MUX Pin Functions*.

Among the three sets of signals:

- Some are routed via the GPIO Matrix (**GPIO0, GPIO1, etc.**), which incorporates internal signal routing circuitry for mapping signals programmatically. It gives the pin access to almost any [peripheral](#) signals. However, the flexibility of programmatic mapping comes at a cost as it might affect the latency of routed signals. For details about connecting to peripheral signals via GPIO Matrix, see [ESP32-C3 Technical Reference Manual](#) > Chapter *IO MUX and GPIO Matrix*.
- Some are directly routed from certain peripherals (**UOTXD, MTCK, etc.**), including UART0, JTAG, SPI0/1, and SPI2 - see Table 2-3 *Peripheral Signals Routed via IO MUX*.

Table 2-3. Peripheral Signals Routed via IO MUX

Pin Function	Signal	Description
UOTXD UORXD	Transmit data Receive data	UART0 interface
MTCK MTDO MTDI MTMS	Test clock Test Data Out Test Data In Test Mode Select	JTAG interface for debugging
SPIQ SPID SPIHD SPIWP SPICLK SPICS...	Master in, slave out Master out, slave in Hold Write protect Clock Chip select	3.3 V SPI0/1 interface for connection to in-package or off-package flash via the SPI bus. It supports 1-, 2-, 4-line SPI modes. See also Section 2.6 Pin Mapping Between Chip and Flash
FSPIQ FSPID FSPIHD FSPIWP FSPICLK FSPICS0	Master in, slave out Master out, slave in Hold Write protect Clock Chip select	SPI2 interface for fast SPI connection. It supports 1-, 2-, 4-line SPI modes

Table 2-4 *IO MUX Pin Functions* shows the IO MUX functions of IO pins.

Table 2-4. IO MUX Pin Functions

Pin No.	IO MUX / GPIO Name ²	IO MUX Function ^{1, 2, 3}					
		FO	Type ³	F1	Type	F2	Type
4	GPIO0	GPIO0	I/O/T	GPIO0	I/O/T		

Cont'd on next page

Table 2-4 – cont'd from previous page

Pin No.	IO MUX / GPIO Name ²	IO MUX Function ^{1, 2, 3}					
		F0	Type ³	F1	Type	F2	Type
5	GPIO1	GPIO1	I/O/T	GPIO1	I/O/T		
6	GPIO2	GPIO2	I/O/T	GPIO2	I/O/T	FSPIQ	I1/O/T
8	GPIO3	GPIO3	I/O/T	GPIO3	I/O/T		
9	GPIO4	MTMS	I1	GPIO4	I/O/T	FSPIHD	I1/O/T
10	GPIO5	MTDI	I1	GPIO5	I/O/T	FSPIWP	I1/O/T
12	GPIO6	MTCK	I1	GPIO6	I/O/T	FSPICLK	I1/O/T
13	GPIO7	MTDO	O/T	GPIO7	I/O/T	FSPID	I1/O/T
14	GPIO8	GPIO8	I/O/T	GPIO8	I/O/T		
15	GPIO9	GPIO9	I/O/T	GPIO9	I/O/T		
16	GPIO10	GPIO10	I/O/T	GPIO10	I/O/T	FSPICSO	I1/O/T
18	GPIO11	GPIO11	I/O/T	GPIO11	I/O/T		
19	GPIO12	SPIHD	I1/O/T	GPIO12	I/O/T		
20	GPIO13	SPIWP	I1/O/T	GPIO13	I/O/T		
21	GPIO14	SPICSO	O/T	GPIO14	I/O/T		
22	GPIO15	SPICLK	O/T	GPIO15	I/O/T		
23	GPIO16	SPID	I1/O/T	GPIO16	I/O/T		
24	GPIO17	SPIQ	I1/O/T	GPIO17	I/O/T		
25	GPIO18	GPIO18	I/O/T	GPIO18	I/O/T		
26	GPIO19	GPIO19	I/O/T	GPIO19	I/O/T		
27	GPIO20	UORXD	I1	GPIO20	I/O/T		
28	GPIO21	UOTXD	O	GPIO21	I/O/T		

¹ **Bold** marks the default pin functions in the default boot mode. See Section [3.1 Chip Boot Mode Control](#).

² Regarding **highlighted** cells, see Section [2.3.3 Restrictions for GPIOs](#).

³ Each IO MUX function (F_n , $n = 0 \sim 2$) is associated with a *type*. The description of *type* is as follows:

- I – input. O – output. T – high impedance.
- I1 – input; if the pin is assigned a function other than F_n , the input signal of F_n is always 1.
- IO – input; if the pin is assigned a function other than F_n , the input signal of F_n is always 0.

2.3.2 Analog Functions

Some IO pins also have **analog functions**, for analog peripherals (such as ADC) in any power mode. Internal analog signals are routed to these analog functions, see Table 2-5 *Analog Signals Routed to Analog Functions*.

Table 2-5. Analog Signals Routed to Analog Functions

Pin Function	Signal	Description
ADC..._CH...	ADC1/2 channel ... signal	ADC1/2 interface
USB_D- USB_D+	Data - Data +	USB Serial/JTAG function
XTAL_32K_N XTAL_32K_P	Negative clock signal Positive clock signal	32 kHz external clock input/output connected to ESP32-C3's crystal or oscillator

Table 2-6 *Analog Functions* shows the analog functions of IO pins.

Table 2-6. Analog Functions

Pin No.	Analog IO Name ^{1, 2}	Analog Function ²	
		FO	F1
4	GPIO0	XTAL_32K_P	ADC1_CH0
5	GPIO1	XTAL_32K_N	ADC1_CH1
6	GPIO2		ADC1_CH2
8	GPIO3		ADC1_CH3
9	GPIO4		ADC1_CH4
10	GPIO5		ADC2_CH0
25	GPIO18	USB_D-	
26	GPIO19	USB_D+	

¹ **Bold** marks the default pin functions in the default boot mode. See Section 3.1 *Chip Boot Mode Control*.

² Regarding **highlighted** cells, see Section 2.3.3 *Restrictions for GPIOs*.

2.3.3 Restrictions for GPIOs

All IO pins of ESP32-C3 have GPIO pin functions. However, the IO pins are multiplexed and can be configured for different purposes based on the requirements. Some IOs have restrictions for usage. It is essential to consider the multiplexed nature and the limitations when using these IO pins.

In tables of this chapter, the following pin functions are highlighted in **red** or **yellow**. These functions indicate pins that require extra caution when used as **GPIO** / **GPIO**:

- **IO Pins** – allocated for communication with in-package flash and NOT recommended for other uses. For details, see Section [2.6 Pin Mapping Between Chip and Flash](#).
 - **IO Pins** – have one of the following important functions:
 - **Strapping pins** – need to be at certain logic levels at startup. See Section [3 Boot Configurations](#).
- Note:**
Strapping pins are highlighted by *Pin Name* or configurations *At Reset*, instead of the pin functions.
- **USB_D+/-** – by default, connected to the USB Serial/JTAG Controller. To function as GPIOs, these pins need to be reconfigured.
 - **JTAG interface** – often used for debugging. See Table [2-3 Peripheral Signals Routed via IO MUX](#). To free these pins up, the pin functions USB_D+/- of the [ESP32-C3 Technical Reference Manual USB Serial/JTAG Controller](#) can be used instead.
 - **UART0 interface** – often used for debugging. See Table [2-3 Peripheral Signals Routed via IO MUX](#).
 - **VDD_SPI** – the power supply pin for flash by default, and can only be used as a GPIO pin if the flash is powered by an external power supply.

For more information about assigning pins, please see Section [2.3.4 Peripheral Pin Assignment](#) and [ESP32-C3 Consolidated Pin Overview](#).

2.3.4 Peripheral Pin Assignment

Table 2-7 *Peripheral Pin Assignment* highlights which pins can be assigned to each peripheral interface according to the following priorities:

- **Priority 1** : Fixed pins connected directly to peripheral signals via IO MUX.
If a peripheral interface does not have priority 1 pins, such as UART1, it can be assigned to any GPIO pins from priority 2 to priority 4.
- Any GPIO pins mapping to peripheral signals via GPIO Matrix, can be priority 2, 3, or 4.
 - **Priority 2** : GPIO pins can be freely used without restrictions.
 - **Priority 3** : GPIO pins should be used with caution, as they may conflict with the following important functions described in Section 2.3.3 *Restrictions for GPIOs*:
 - * **GPIO2, GPIO8, GPIO9** : Strapping pins.
 - * **GPIO18, GPIO19** : USB Serial/JTAG interface.
 - * **GPIO4, GPIO5, GPIO6, GPIO7** : JTAG interface.
 - * **GPIO20, GPIO21** : UART0 interface.
 - * **GPIO11** : The VDD_SPI pin. The power supply pin for flash by default, and can only be reconfigured as a GPIO pin if the flash is powered by an external power supply.
 - **Priority 4** : GPIO pins already allocated or not recommended for use, as described in Section 2.3.3 *Restrictions for GPIOs*:
 - * **GPIO12, GPIO13, GPIO14, GPIO15, GPIO16, GPIO17** : SPI0/1 interface connected to the in-package flash, or recommended for the off-package flash.

If a peripheral interface does not have priority 2 to 4 pins, such as USB Serial/JTAG, it means it can be assigned only to priority 1 pins.

Note:

- For details about which peripheral signals are connected to IO MUX pins, please refer to Section 2.3.1 *IO MUX Functions*.
- For details about which peripheral signals can be assigned to GPIO pins, please refer to [ESP32-C3 Technical Reference Manual](#) > Chapter IO MUX and GPIO Matrix > Section Peripheral Signal List.

Table 2-7. Peripheral Pin Assignment

Pin No.	Pin Name	USB Serial/JTAG ¹	JTAG	ADC1	ADC2	UART0 ²	SPIO/1 ²	SPI2 ²	UART1	I2C
1	LNA_IN									
2	VDD3P3									
3	VDD3P3									
4	XTAL_32K_P			ADC1_CH0 (P1)		GPIO0 (P2)	GPIO0 (P2)	GPIO0 (P2)	GPIO0 (P2)	GPIO0 (P2)
5	XTAL_32K_N			ADC1_CH1 (P1)		GPIO1 (P2)	GPIO1 (P2)	GPIO1 (P2)	GPIO1 (P2)	GPIO1 (P2)
6	GPIO2			ADC1_CH2 (P1)		GPIO2 (P3)	GPIO2 (P3)	FSPiQ (P1)	GPIO2 (P3)	GPIO2 (P3)
7	CHIP_EN									
8	GPIO3			ADC1_CH3 (P1)		GPIO3 (P2)	GPIO3 (P2)	GPIO3 (P2)	GPIO3 (P2)	GPIO3 (P2)
9	MTMS		MTMS (P1)	ADC1_CH4 (P1)		GPIO4 (P3)	GPIO4 (P3)	FSPiHD (P1)	GPIO4 (P3)	GPIO4 (P3)
10	MTDI		MTDI (P1)		ADC2_CH0 (P1)	GPIO5 (P3)	GPIO5 (P3)	FSPiWP (P1)	GPIO5 (P3)	GPIO5 (P3)
11	VDD3P3_RTC									
12	MTCK		MTCK (P1)			GPIO6 (P3)	GPIO6 (P3)	FSPiCLK (P1)	GPIO6 (P3)	GPIO6 (P3)
13	MTDO		MTDO (P1)			GPIO7 (P3)	GPIO7 (P3)	FSPiD (P1)	GPIO7 (P3)	GPIO7 (P3)
14	GPIO8					GPIO8 (P3)	GPIO8 (P3)	GPIO8 (P3)	GPIO8 (P3)	GPIO8 (P3)
15	GPIO9					GPIO9 (P3)	GPIO9 (P3)	GPIO9 (P3)	GPIO9 (P3)	GPIO9 (P3)
16	GPIO10					GPIO10 (P2)	GPIO10 (P2)	FSPiCS0 (P1)	GPIO10 (P2)	GPIO10 (P2)
17	VDD3P3_CPU									
18	VDD_SPI					GPIO11 (P3)	GPIO11 (P3)	GPIO11 (P3)	GPIO11 (P3)	GPIO11 (P3)
19	SPIHD					GPIO12 (P4)	SPIHD (P1)	GPIO12 (P4)	GPIO12 (P4)	GPIO12 (P4)
20	SPIWP					GPIO13 (P4)	SPIWP (P1)	GPIO13 (P4)	GPIO13 (P4)	GPIO13 (P4)
21	SPICS0					GPIO14 (P4)	SPICS0 (P1)	GPIO14 (P4)	GPIO14 (P4)	GPIO14 (P4)
22	SPICLK					GPIO15 (P4)	SPICLK (P1)	GPIO15 (P4)	GPIO15 (P4)	GPIO15 (P4)
23	SPID					GPIO16 (P4)	SPID (P1)	GPIO16 (P4)	GPIO16 (P4)	GPIO16 (P4)
24	SPIQ					GPIO17 (P4)	SPIQ (P1)	GPIO17 (P4)	GPIO17 (P4)	GPIO17 (P4)
25	GPIO18		USB_D- (P1)			GPIO18 (P3)	GPIO18 (P3)	GPIO18 (P3)	GPIO18 (P3)	GPIO18 (P3)
26	GPIO19		USB_D+ (P1)			GPIO19 (P3)	GPIO19 (P3)	GPIO19 (P3)	GPIO19 (P3)	GPIO19 (P3)
27	UORXD					UORXD (P1)	GPIO20 (P3)	GPIO20 (P3)	GPIO20 (P3)	GPIO20 (P3)
28	UOTXD					UOTXD (P1)	GPIO21 (P3)	GPIO21 (P3)	GPIO21 (P3)	GPIO21 (P3)
29	XTAL_N									
30	XTAL_P									
31	VDDA									
32	VDDA									
33	GND									

¹ For USB Serial/JTAG, the USB_D- and USB_D+ can be swapped by configuring the USB_SERIAL_JTAG_EXCHG_PINS bit according to [ESP32-C3 Technical Reference Manual](#).

² Signals of UART0, SPIO/1, and SPI2 interface can be mapped to any GPIO pins through the GPIO Matrix, regardless of whether they are directly routed to fixed pins.

³ For ESP32-C3FH4AZ and ESP32-C3FH4X, pins within the frame (namely pin 19 ~ pin 24) are not available.

2.4 Analog Pins

Table 2-8. Analog Pins

Pin No.	Pin Name	Pin Type	Pin Function
1	LNA_IN	I/O	Low Noise Amplifier (RF LNA) input / output signals
7	CHIP_EN	I	High: on, enables the chip (powered up). Low: off, disables the chip (powered down). Note: Do not leave the CHIP_EN pin floating.
29	XTAL_N	—	External clock input/output connected to the chip's crystal or oscillator. P/N means differential clock positive/negative.
30	XTAL_P	—	

2.5 Power Supply

2.5.1 Power Pins

The chip is powered via the power pins described in Table 2-9 *Power Pins*.

Table 2-9. Power Pins

Pin No.	Pin Name	Direction	Power Supply ^{1,2}	
			Power Domain / Other	IO Pins ³
2	VDD3P3	Input	Analog power domain	
3	VDD3P3	Input	Analog power domain	
11	VDD3P3_RTC	Input	RTC and part of Digital power domains	RTC IO
17	VDD3P3_CPU	Input	Digital power domain	Digital IO
18	VDD_SPI	Input	In-package flash (backup power line)	
		Output	In-package and off-package flash	SPI IO
31	VDDA	Input	Analog power domain	
32	VDDA	Input	Analog power domain	
33	GND	—	External ground connection	

¹ See in conjunction with Section 2.5.2 *Power Scheme*.

² For recommended and maximum voltage and current, see Section 5.1 *Absolute Maximum Ratings* and Section 5.2 *Recommended Operating Conditions*.

³ Digital IO pins are those powered by VDD3P3_CPU, and RTC IO pins are those powered by VDD3P3_RTC and so on, as shown in Figure 2-3 *ESP32-C3 Power Scheme*. See also Table 2-1 *Pin Overview* > Column *Pin Providing Power*.

2.5.2 Power Scheme

The power scheme is shown in Figure 2-3 *ESP32-C3 Power Scheme*.

The components on the chip are powered via voltage regulators.

Table 2-10. Voltage Regulators

Voltage Regulator	Output	Power Supply
Digital	1.1 V	Digital power domain
Low-power	1.1 V	RTC power domain

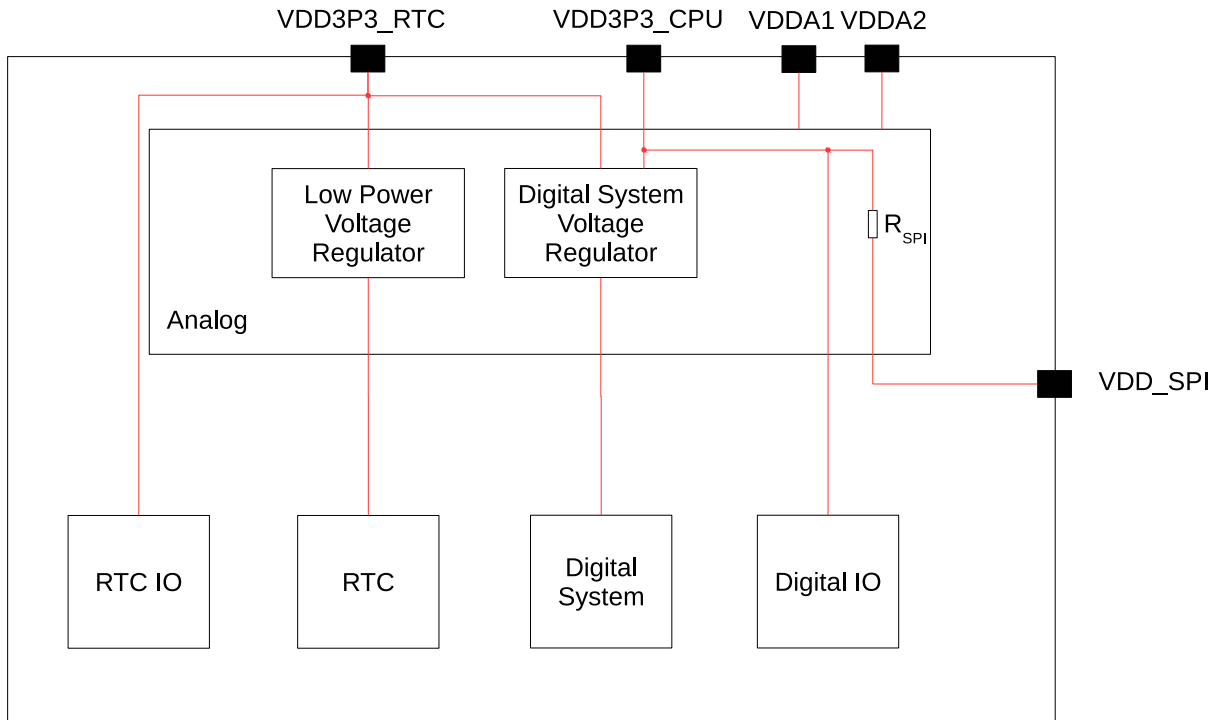

Figure 2-3. ESP32-C3 Power Scheme

2.5.3 Chip Power-up and Reset

Once the power is supplied to the chip, its power rails need a short time to stabilize. After that, CHIP_EN – the pin used for power-up and reset – is pulled high to activate the chip. For information on CHIP_EN as well as power-up and reset timing, see Figure 2-4 and Table 2-11.

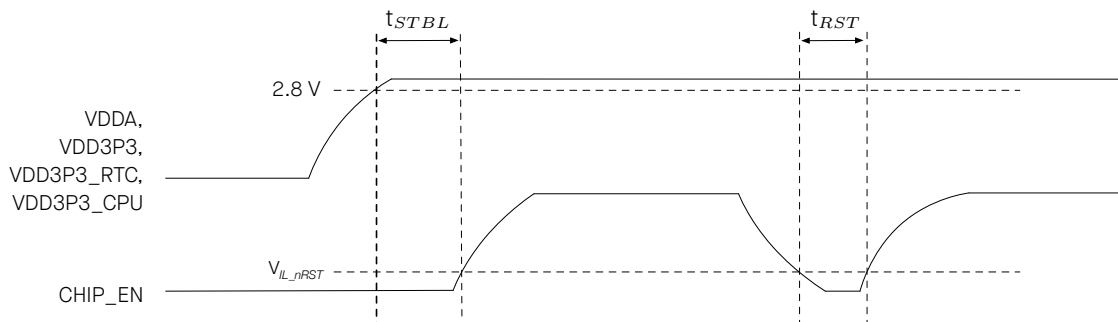

Figure 2-4. Visualization of Timing Parameters for Power-up and Reset

Table 2-11. Description of Timing Parameters for Power-up and Reset

Parameter	Description	Min (μs)
t_{STBL}	Time reserved for the power rails of VDDA, VDD3P3, VDD3P3_RTC, and VDD3P3_CPU to stabilize before the CHIP_EN pin is pulled high to activate the chip	50
t_{RST}	Time reserved for CHIP_EN to stay below V_{IL_nRST} to reset the chip (see Table 5-4)	50

2.6 Pin Mapping Between Chip and Flash

Table 2-12 lists the pin mapping between the chip and flash for all SPI modes.

For chip variants with in-package flash (see Table 1-1 *ESP32-C3 Series Comparison*), the pins allocated for communication with in-package flash can be identified depending on the SPI mode used.

For off-package flash, these are the recommended pin mappings.

For more information on SPI controllers, see also Section 4.2.1.2 *SPI Controller*.

Notice:

Do not use the pins connected to in-package flash for any other purposes.

Table 2-12. Pin Mapping Between Chip and In-package Flash

Pin No.	Pin Name	Single SPI	Dual SPI	Quad SPI / QPI
		Flash	Flash	Flash
22	SPICLK	CLK	CLK	CLK
21	SPICSO ¹	CS#	CS#	CS#
23	SPID	DI	DI	DI
24	SPIQ	DO	DO	DO
20	SPIWP	WP#	WP#	WP#
19	SPIHD	HOLD#	HOLD#	HOLD#

¹ CS0 is for in-package flash

3 Boot Configurations

The chip allows for configuring the following boot parameters through [strapping pins](#) and [eFuse parameters](#) at power-up or a hardware reset, without microcontroller interaction.

- **Chip boot mode**
 - Strapping pins: GPIO2, GPIO8, and GPIO9
- **ROM message printing**
 - Strapping pin: GPIO8
 - eFuse parameters: EFUSE_UART_PRINT_CONTROL and EFUSE_USB_PRINT_CHANNEL

The default values of all the above eFuse parameters are 0, which means that they are not burnt. Given that eFuse is one-time programmable, once programmed to 1, it can never be reverted to 0. For how to program eFuse parameters, please refer to [ESP32-C3 Technical Reference Manual](#) > Chapter *eFuse Controller*.

The default values of the strapping pins, namely the logic levels, are determined by pins' internal weak pull-up/pull-down resistors at reset if the pins are not connected to any circuit, or connected to an external high-impedance circuit.

Table 3-1. Default Configuration of Strapping Pins

Strapping Pin	Default Configuration	Bit Value
GPIO2	Floating	–
GPIO8	Floating	–
GPIO9	Weak pull-up	1

To change the bit values, the strapping pins should be connected to external pull-down/pull-up resistances. If the ESP32-C3 is used as a device by a host MCU, the strapping pin voltage levels can also be controlled by the host MCU.

All strapping pins have latches. At Chip Reset, the latches sample the bit values of their respective strapping pins and store them until the chip is powered down or shut down. The states of latches cannot be changed in any other way. It makes the strapping pin values available during the entire chip operation, and the pins are freed up to be used as regular IO pins after reset. For details on Chip Reset, see [ESP32-C3 Technical Reference Manual](#) > Chapter *Reset and Clock*.

The timing of signals connected to the strapping pins should adhere to the *setup time* and *hold time* specifications in Table 3-2 and Figure 3-1.

Table 3-2. Description of Timing Parameters for the Strapping Pins

Parameter	Description	Min (ms)
t_{SU}	<i>Setup time</i> is the time reserved for the power rails to stabilize before the CHIP_EN pin is pulled high to activate the chip.	0
t_H	<i>Hold time</i> is the time reserved for the chip to read the strapping pin values after CHIP_EN is already high and before these pins start operating as regular IO pins.	3

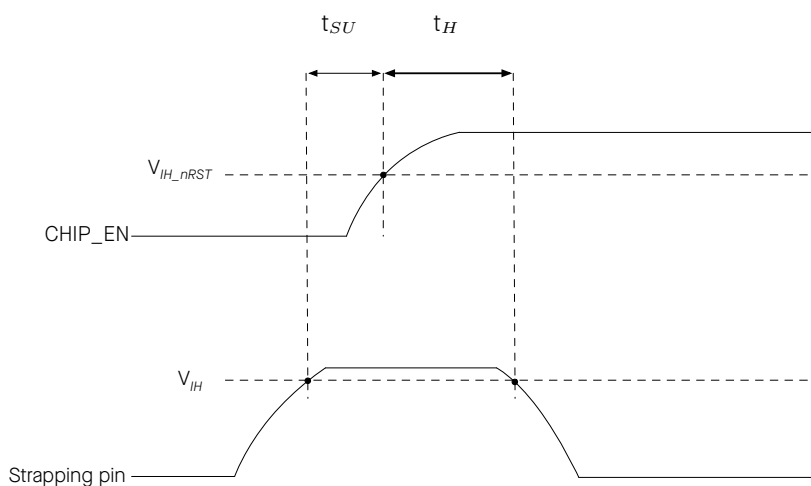

Figure 3-1. Visualization of Timing Parameters for the Strapping Pins

3.1 Chip Boot Mode Control

GPIO2, GPIO8, and GPIO9 control the boot mode after the reset is released. See Table 3-3 *Chip Boot Mode Control*.

Table 3-3. Chip Boot Mode Control

Boot Mode	GPIO2 ²	GPIO8	GPIO9
SPI boot mode	1	Any value	1
Joint download boot mode ³	1	1	0

¹ **Bold** marks the default value and configuration.

² GPIO2 actually does not determine SPI Boot and Joint Download Boot mode, but it is recommended to pull this pin up due to glitches.

³ Joint Download Boot mode supports the following download methods:

- USB-Serial-JTAG Download Boot
- UART Download Boot

In SPI Boot mode, the ROM bootloader loads and executes the program from SPI flash to boot the system.

In Joint Download Boot mode, users can download binary files into flash using UART0 or USB interface. It is also possible to download binary files into SRAM and execute it from SRAM.

In addition to SPI Boot and Joint Download Boot modes, ESP32-C3 also supports SPI Download Boot mode. For details, please see [ESP32-C3 Technical Reference Manual](#) > Chapter *Chip Boot Control*.

3.2 ROM Messages Printing Control

During the boot process, the messages by the ROM code can be printed to:

- (Default) UART0 and USB Serial/JTAG controller

- UART0
- USB Serial/JTAG controller

EFUSE_UART_PRINT_CONTROL and GPIO8 control ROM messages printing to **UART0** as shown in Table 3-4 *UART0 ROM Message Printing Control*.

Table 3-4. UART0 ROM Message Printing Control

UART0 ROM Code Printing	EFUSE_UART_PRINT_CONTROL	GPIO8
Enabled	0	Ignored
	1	0
	2	1
Disabled	1	1
	2	0
	3	Ignored

¹ **Bold** marks the default value and configuration.

EFUSE_USB_PRINT_CHANNEL controls the printing to **USB Serial/JTAG controller** as shown in Table 3-5 *USB Serial/JTAG ROM Message Printing Control*.

Table 3-5. USB Serial/JTAG ROM Message Printing Control

USB Serial/JTAG ROM Code Printing	EFUSE_DIS_USB_SERIAL_JTAG ²	EFUSE_USB_PRINT_CHANNEL
Enabled	0	0
Disabled	0	1
	1	Ignored

¹ **Bold** marks the default value and configuration.

² EFUSE_DIS_USB_SERIAL_JTAG controls whether to disable USB Serial/JTAG.

4 Functional Description

4.1 System

This section describes the core of the chip's operation, covering its microprocessor, memory organization, system components, and security features.

4.1.1 Microprocessor and Master

This subsection describes the core processing units within the chip and their capabilities.

4.1.1.1 High-Performance CPU

ESP32-C3 has a low-power 32-bit RISC-V single-core microprocessor with the following features:

- Four-stage pipeline that supports a clock frequency of up to 160 MHz
- RV32IMC ISA
- 32-bit multiplier and 32-bit divider
- Up to 32 vectored interrupts at seven priority levels
- Up to 8 hardware breakpoints/watchpoints
- Up to 16 PMP regions
- JTAG for debugging

For details, see [ESP32-C3 Technical Reference Manual](#) > Chapter *High-Performance CPU*.

4.1.1.2 GDMA Controller

ESP32-C3 has a general DMA controller (GDMA) with six independent channels, i.e. three transmit channels and three receive channels. These six channels are shared by peripherals with DMA feature. The GDMA controller implements a fixed-priority scheme among these channels, whose priority can be configured.

The GDMA controller controls data transfer using linked lists. It allows peripheral-to-memory and memory-to-memory data transfer at a high speed. All channels can access internal RAM.

Peripherals on ESP32-C3 with DMA feature are SPI2, UHCIO, I2S, AES, SHA, and ADC.

For details, see [ESP32-C3 Technical Reference Manual](#) > Chapter *GDMA Controller (DMA)*.

4.1.2 Memory Organization

This subsection describes the memory arrangement to explain how data is stored, accessed, and managed for efficient operation.

Figure 4-1 illustrates the address mapping structure of ESP32-C3.

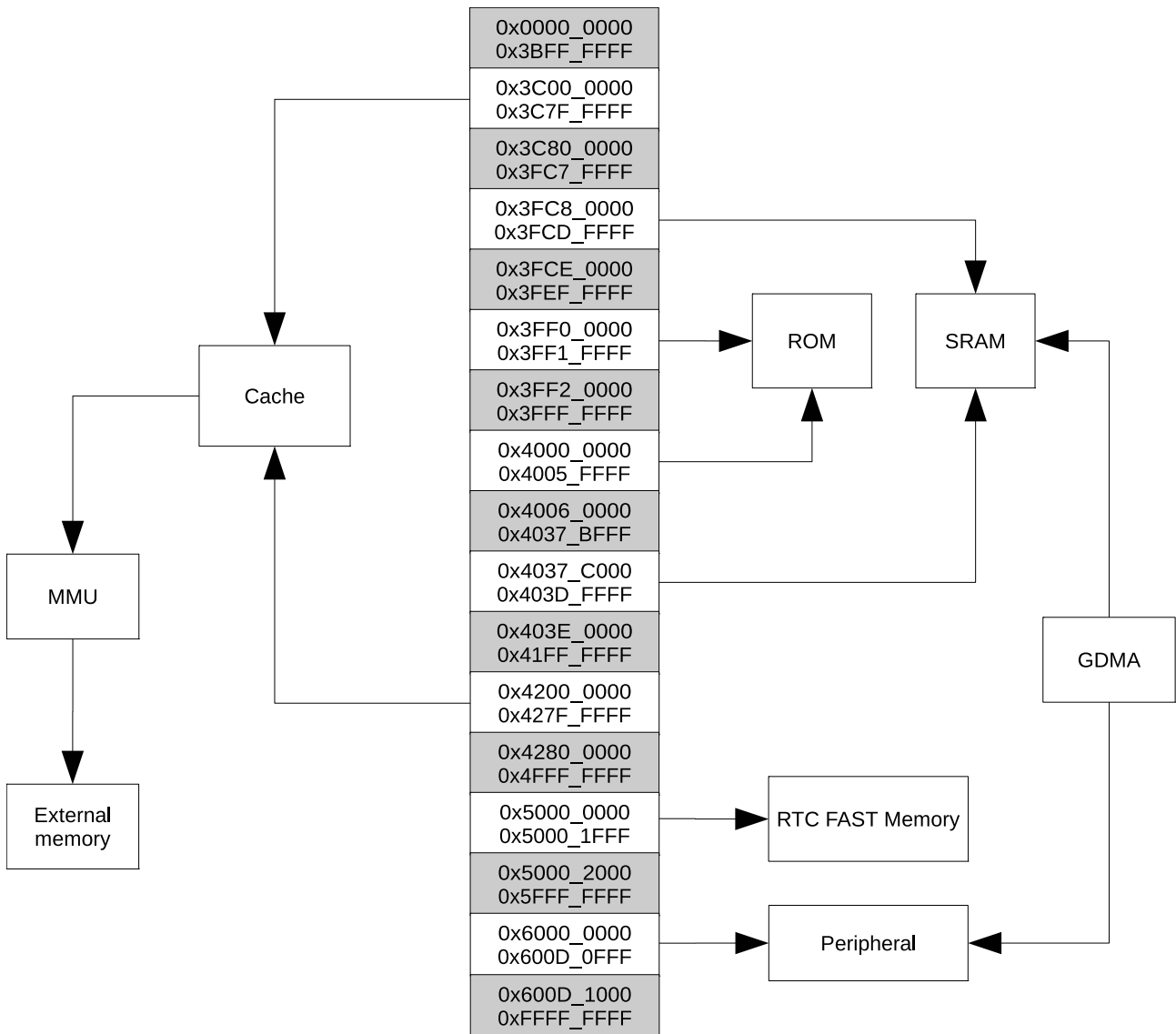

Figure 4-1. Address Mapping Structure

Note:

The memory space with gray background is not available for use.

4.1.2.1 Internal Memory

The internal memory of ESP32-C3 refers to the memory integrated on the chip die or in the chip package, including ROM, SRAM, eFuse, and flash.

- **384 KB of ROM:** for booting and core functions
- **400 KB of on-chip SRAM:** for data and instructions, running at a configurable frequency of up to 160 MHz. Of the 400 KB SRAM, 16 KB is configured for cache
- **RTC FAST memory:** 8 KB of SRAM that can be accessed by the main CPU. It can retain data in Deep-sleep mode
- **4 Kbit of eFuse:** 1792 bits are reserved for your data, such as encryption key and device ID

- **In-package flash**

- See flash size in Chapter 1 [ESP32-C3 Series Comparison](#)
- For specifications, refer to Section 5.7 [Memory Specifications](#).

For details, see [ESP32-C3 Technical Reference Manual](#) > Chapter *System and Memory*.

4.1.2.2 External Memory

ESP32-C3 allows connection to memories outside the chip's package via the SPI, Dual SPI, Quad SPI, and QPI interfaces.

CPU's instruction memory space and read-only data memory space can map into the off-package flash of ESP32-C3, whose size can be 16 MB at most. ESP32-C3 supports hardware encryption/decryption based on XTS-AES to protect developers' programs and data in flash.

Through high-speed caches, ESP32-C3 can support at a time up to:

- 8 MB of instruction memory space which can map into flash as individual blocks of 64 KB. 8-bit, 16-bit and 32-bit reads are supported.
- 8 MB of data memory space which can map into flash as individual blocks of 64 KB. 8-bit, 16-bit and 32-bit reads are supported.

Note:

After ESP32-C3 is initialized, software can customize the mapping of off-package flash into the CPU address space.

For details, see [ESP32-C3 Technical Reference Manual](#) > Chapter *System and Memory*.

4.1.2.3 Cache

ESP32-C3 has an eight-way set associative cache. This cache is read-only and has the following features:

- Size: 16 KB
- Block size: 32 bytes
- Pre-load function
- Lock function
- Critical word first and early restart

For details, see [ESP32-C3 Technical Reference Manual](#) > Chapter *System and Memory*.

4.1.2.4 eFuse Controller

The eFuse memory is a one-time programmable memory that stores parameters and user data, and the eFuse controller of ESP32-C3 is used to program and read this eFuse memory.

Feature List

- Configurable write protection

- Configurable read protection
- Various hardware encoding schemes against data corruption

For details, see [ESP32-C3 Technical Reference Manual](#) > Chapter *eFuse Controller*.

4.1.3 System Components

This subsection describes the essential components that contribute to the overall functionality and control of the system.

4.1.3.1 IO MUX and GPIO Matrix

ESP32-C3 has 22 or 16 GPIO pins which can be assigned various functions by configuring corresponding registers. Besides digital signals, some GPIOs can be also used for analog functions, such as ADC.

All GPIOs have selectable internal pull-up or pull-down, or can be set to high impedance. When these GPIOs are configured as an input, the input value can be read by software through the register. Input GPIOs can also be set to generate edge-triggered or level-triggered CPU interrupts. All digital IO pins are bi-directional, non-inverting and tristate, including input and output buffers with tristate control. These pins can be multiplexed with other functions, such as the UART, SPI, etc. For low-power operations, the GPIOs can be set to holding state.

The IO MUX and the GPIO matrix are used to route signals from peripherals to GPIO pins. Together they provide highly configurable I/O. Using GPIO Matrix, peripheral input signals can be configured from any IO pins while peripheral output signals can be configured to any IO pins.

For details, see [ESP32-C3 Technical Reference Manual](#) > Chapter *IO MUX and GPIO Matrix*.

4.1.3.2 Reset

The ESP32-C3 chip provides four types of reset that occur at different levels, namely CPU Reset, Core Reset, System Reset, and Chip Reset. Except for Chip Reset, all reset types preserve the data stored in internal memory.

Feature List

- Support four reset levels:
 - CPU Reset: Only resets CPU core. Once such reset is released, the instructions from the CPU reset vector will be executed
 - Core Reset: Resets the whole digital system except RTC, including CPU, peripherals, Wi-Fi, Bluetooth® LE, and digital GPIOs
 - System Reset: Resets the whole digital system, including RTC
 - Chip Reset: Resets the whole chip
- Support software reset and hardware reset:
 - Software Reset: The CPU can trigger a software reset by configuring the corresponding registers
 - Hardware Reset: Hardware reset is directly triggered by the circuit

For details, see [ESP32-C3 Technical Reference Manual](#) > Chapter *Reset and Clock*.

4.1.3.3 Clock

For details, see [ESP32-C3 Technical Reference Manual](#) > Chapter *Reset and Clock*.

CPU Clock

The CPU clock has three possible sources:

- External main crystal clock
- Fast RC oscillator (typically about 17.5 MHz, and adjustable)
- PLL clock

The application can select the clock source from the three clocks above. The selected clock source drives the CPU clock directly, or after division, depending on the application. Once the CPU is reset, the default clock source would be the external main crystal clock divided by 2.

Note:

ESP32-C3 is unable to operate without an external main crystal clock.

RTC Clock

The RTC slow clock is used for RTC counter, RTC watchdog and low-power controller. It has three possible sources:

- External low-speed (32 kHz) crystal clock
- Internal slow RC oscillator (typically about 136 kHz, and adjustable)
- Internal fast RC oscillator divided clock (derived from the fast RC oscillator divided by 256)

The RTC fast clock is used for RTC peripherals and sensor controllers. It has two possible sources:

- External main crystal clock divided by 2
- Internal fast RC oscillator divide-by-N clock (typically about 17.5 MHz, and adjustable)

4.1.3.4 Interrupt Matrix

The Interrupt Matrix in the ESP32-C3 chip independently routes peripheral interrupt sources to the ESP-RISC-V CPU's peripheral interrupts, to timely inform CPU to process the coming interrupts.

Feature List

- Accept 62 peripheral interrupt sources as input
- Generate 31 CPU peripheral interrupts to CPU as output
- Query current interrupt status of peripheral interrupt sources
- Configure priority, type, threshold, and enable signal of CPU interrupts

For details, see [ESP32-C3 Technical Reference Manual](#) > Chapter *Interrupt Matrix*.

4.1.3.5 System Timer

ESP32-C3 integrates a 52-bit system timer, which has two 52-bit counters and three comparators. The system timer has the following features:

- Counters with a fixed clock frequency of 16 MHz
- Three types of independent interrupts generated according to alarm value
- Two alarm modes: target mode and period mode
- 52-bit target alarm value and 26-bit periodic alarm value
- Automatic reload of counter value
- Counters can be stalled if the CPU is stalled or in OCD mode

For details, see [ESP32-C3 Technical Reference Manual](#) > Chapter System Timer.

4.1.3.6 Power Management Unit

The ESP32-C3 has an advanced Power Management Unit (PMU). It can be flexibly configured to power up different power domains of the chip to achieve the best balance between chip performance, power consumption, and wakeup latency.

Configuring the PMU is a complex procedure. To simplify power management for typical scenarios, there are the following **predefined power modes** that power up different combinations of power domains:

- **Active mode** – The CPU, RF circuits, and all peripherals are on. The chip can process data, receive, transmit, and listen.
- **Modem-sleep mode** – The CPU is on, but the clock frequency can be reduced. The wireless connections can be configured to remain active as RF circuits are periodically switched on when required.
- **Light-sleep mode** – The CPU stops running, and can be optionally powered on. The chip can be woken up via all wake up mechanisms: MAC, RTC timer, or external interrupts. Wireless connections can remain active. Some groups of digital peripherals can be optionally shut down.
- **Deep-sleep mode** – Only RTC is powered on. Wireless connection data is stored in RTC memory.

For power consumption in different power modes, see Section [5.6 Current Consumption](#).

Figure [4-2 Components and Power Domains](#) and the following Table [4-1](#) show the distribution of chip components between **power domains** and **power subdomains**.

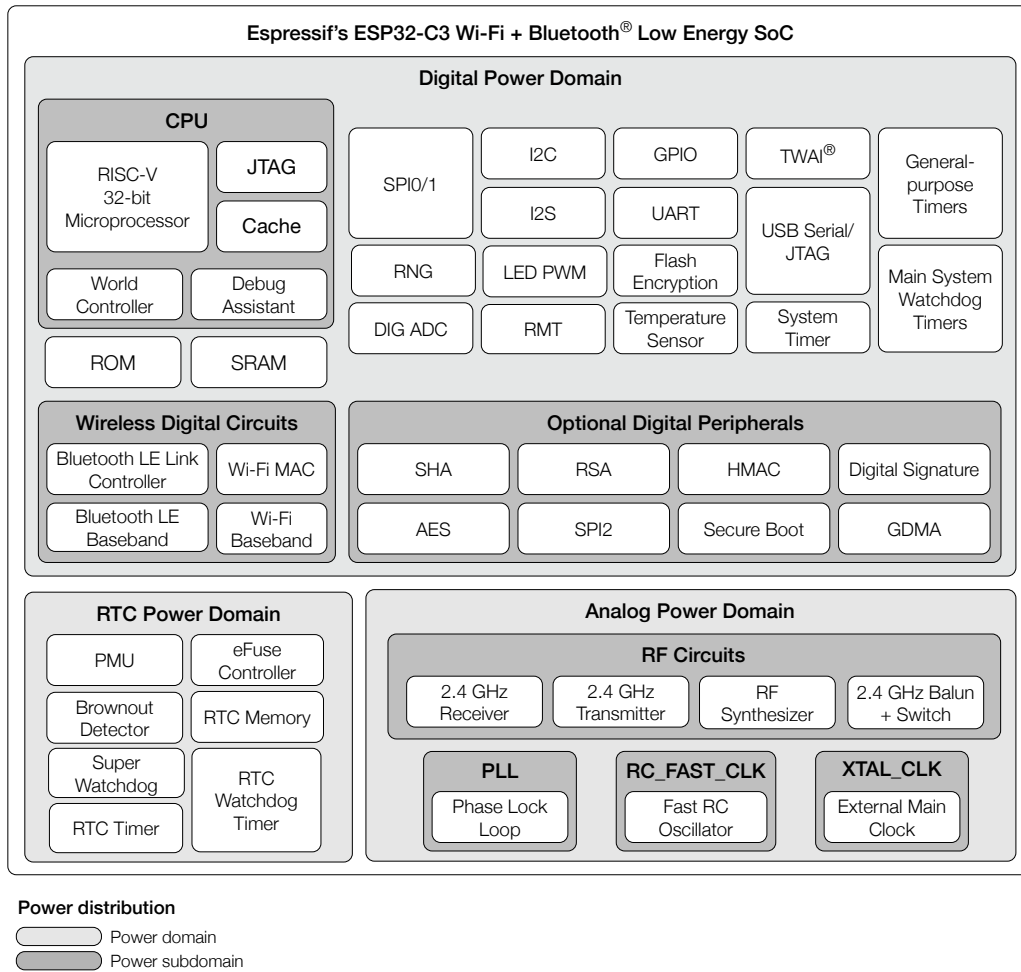

Figure 4-2. Components and Power Domains

Table 4-1. Components and Power Domains

Power Mode	Power Domain	RTC	Digital			Analog				
			CPU	Optional Digital Periph	Wireless Digital Circuits	FOSC_CLK	XTAL_CLK	PLL	RF Circuits	
Active		ON	ON	ON	ON	ON	ON	ON	ON	ON
Modem-sleep		ON	ON	ON	ON ¹	ON	ON	ON	ON	OFF ²
Light-sleep		ON	ON	OFF ¹	ON ¹	ON	OFF	OFF	OFF	OFF ²
Deep-sleep		ON	OFF	OFF	OFF	ON	OFF	OFF	OFF	OFF

¹ Configurable, see the TRM.

² If Wireless Digital Circuits are on, RF circuits are periodically switched on when required by internal operation to keep active wireless connections running.

For details, see [ESP32-C3 Technical Reference Manual](#) > Chapter *Low-Power Management (RTC_CNTL)*.

4.1.3.7 Timer Group

ESP32-C3 has two 54-bit general-purpose timers, which are based on 16-bit prescalers and 54-bit auto-reload-capable up/down-timers.

The timers' features are summarized as follows:

- A 16-bit clock prescaler, from 1 to 65536
- A 54-bit time-base counter programmable to be incrementing or decrementing
- Able to read real-time value of the time-base counter
- Halting and resuming the time-base counter
- Programmable alarm generation
- Level interrupt generation

For details, see [ESP32-C3 Technical Reference Manual](#) > Chapter *Timer Group (TIMG)*.

4.1.3.8 Watchdog Timers

For details, see [ESP32-C3 Technical Reference Manual](#) > Chapter *Watchdog Timers*.

Digital Watchdog Timers

ESP32-C3 contains three digital watchdog timers: one in each of the two timer groups (called Main System Watchdog Timers, or MWDT) and one in the RTC module (called the RTC Watchdog Timer, or RWDT).

During the flash boot process, RWDT and the MWDT in timer group 0 (TIMGO) are enabled automatically in order to detect and recover from booting errors.

Digital watchdog timers have the following features:

- Four stages, each with a programmable timeout value. Each stage can be configured, enabled and disabled separately
- Interrupt, CPU reset, or core reset for MWDT upon expiry of each stage; interrupt, CPU reset, core reset, or system reset for RWDT upon expiry of each stage
- 32-bit expiry counter
- Write protection, to prevent RWDT and MWDT configuration from being altered inadvertently
- Flash boot protection
If the boot process from an SPI flash does not complete within a predetermined period of time, the watchdog will reboot the entire main system.

Analog Watchdog Timer

ESP32-C3 also has one analog watchdog timer: RTC super watchdog timer (SWD). It is an ultra-low-power circuit in analog domain that helps to prevent the system from operating in a sub-optimal state and resets the system if required.

SWD has the following features:

- Ultra-low power

- Interrupt to indicate that the SWD timeout period is close to expiring
- Various dedicated methods for software to feed SWD, which enables SWD to monitor the working state of the whole operating system

4.1.3.9 XTAL32K Watchdog Timers (XTWDT)

The XTAL32K watchdog timer on ESP32-C3 monitors the status of the 32 kHz external crystal. When detecting the oscillation failure of this clock, it changes the slow clock source of RTC. The clock source frequency is configurable.

For details, see [ESP32-C3 Technical Reference Manual](#) > Chapter *XTAL32K Watchdog Timers (XTWDT)*.

4.1.3.10 Permission Control

ESP32-C3 includes a Permission Controller (PMS), which allocates the hardware resources (memory and peripherals) to two isolated environments, thereby realizing the separation of privileged and unprivileged environments.

Feature List

- Independent access management in a privileged environment and unprivileged environment
- Independent access management to internal memory, including
 - CPU access to internal memory
 - GDMA access to internal memory
- Independent access management to external memory, including
 - CPU to external memory via SPI1
 - CPU to external memory via Cache
- Independent access management to peripheral regions, including
 - CPU access to peripheral regions
 - Interrupt upon unsupported access alignment
- Address splitting for more flexible access management
- Register locks to secure the integrity of access management related registers
- Interrupt upon unauthorized access

For details, see [ESP32-C3 Technical Reference Manual](#) > Chapter *Permission Control (PMS)*.

4.1.3.11 World Controller (WCL)

The hardware and software resources on ESP32-C3 can be partitioned into Secure World and Non-secure World. Transitions between these worlds are controlled and logged by the World Controller.

Feature List

- Secure World (World0):
 - Can access all peripherals and memories;
 - Performs all security related operations, such as user authentication, secure communication, and data encryption and decryption, etc.
- Non-secure World (World1):
 - Can access some peripherals and memories;
 - Performs other operations, such as user operation and different applications, etc.

For details, see [ESP32-C3 Technical Reference Manual](#) > Chapter *World Controller (WCL)*.

4.1.3.12 System Registers

The System Registers in the ESP32-C3 chip are used to configure various auxiliary chip features.

Feature List

- Control system and memory
- Control clock
- Control software interrupt
- Control low-power management
- Control peripheral clock gating and reset

For details, see [ESP32-C3 Technical Reference Manual](#) > Chapter *System Registers (HP_SYSREG)*.

4.1.3.13 Debug Assistant

The Debug Assistant provides a set of functions to help locate bugs and issues during software debugging. It offers various monitoring capabilities and logging features to assist in identifying and resolving software errors efficiently.

Feature List

- **Read/write monitoring:** Monitors whether the CPU bus has read from or written to a specified address space. A detected read or write will trigger an interrupt.
- **Stack pointer (SP) monitoring:** Monitors whether the SP exceeds the specified address space. A bounds violation will trigger an interrupt.
- **Program counter (PC) logging:** Records PC value. The developer can get the last PC value at the most recent CPU reset.
- **Bus access logging:** Records the information about bus access. When the CPU or DMA writes a specified value, the Debug Assistant module will record the address and PC value of this write operation, and push the data to the SRAM.

For details, see [ESP32-C3 Technical Reference Manual](#) > Chapter *Debug Assistant (ASSIST_DEBUG)*.

4.1.4 Cryptography and Security Component

This subsection describes the security features incorporated into the chip, which safeguard data and operations.

4.1.4.1 AES Accelerator

ESP32-C3 integrates an Advanced Encryption Standard (AES) accelerator, which is a hardware device that speeds up computation using AES algorithm significantly, compared to AES algorithms implemented solely in software. The AES accelerator integrated in ESP32-C3 has two working modes, which are Typical AES and DMA-AES.

Feature List

- Typical AES working mode
 - AES-128/AES-256 encryption and decryption
- DMA-AES working mode
 - AES-128/AES-256 encryption and decryption
 - Block cipher mode
 - * ECB (Electronic Codebook)
 - * CBC (Cipher Block Chaining)
 - * OFB (Output Feedback)
 - * CTR (Counter)
 - * CFB8 (8-bit Cipher Feedback)
 - * CFB128 (128-bit Cipher Feedback)
 - Interrupt on completion of computation

For details, see [ESP32-C3 Technical Reference Manual](#) > Chapter *AES Accelerator (AES)*.

4.1.4.2 HMAC Accelerator

The HMAC Accelerator (HMAC) module is designed to compute Message Authentication Codes (MACs) using the SHA-256 Hash algorithm and keys as described in RFC 2104. It provides hardware support for HMAC computations, significantly reducing software complexity and improving performance.

Feature List

- Standard HMAC-SHA-256 algorithm
- Hash result only accessible by configurable hardware peripheral (in downstream mode)
- Compatible to challenge-response authentication algorithm
- Generates required keys for the Digital Signature (DS) peripheral (in downstream mode)
- Re-enables soft-disabled JTAG (in downstream mode)

For details, see the [ESP32-C3 Technical Reference Manual](#) > Chapter *HMAC Accelerator*.

4.1.4.3 RSA Accelerator

The RSA accelerator provides hardware support for high-precision computation used in various RSA asymmetric cipher algorithms, significantly improving their run time and reducing their software complexity. Compared with RSA algorithms implemented solely in software, this hardware accelerator can speed up RSA algorithms significantly.

Feature List

- Large-number modular exponentiation with two optional acceleration options, operands width up to 3072 bits
- Large-number modular multiplication, operands width up to 3072 bits
- Large-number multiplication, operands width up to 1536 bits
- Operands of different widths
- Interrupt on completion of computation

For details, see the [ESP32-C3 Technical Reference Manual](#) > Chapter *RSA Accelerator*.

4.1.4.4 SHA Accelerator

The SHA Accelerator (SHA) is a hardware device that speeds up SHA algorithm significantly, compared to SHA algorithm implemented solely in software. The SHA accelerator integrated in ESP32-C3 has two working modes, which are Typical SHA and DMA-SHA.

Feature List

- The following hash algorithms introduced in [FIPS PUB 180-4 Spec](#).
 - SHA-1
 - SHA-224
 - SHA-256
- Two working modes
 - Typical SHA
 - DMA-SHA
- Interleaved function when working in Typical SHA working mode
- Interrupt function when working in DMA-SHA working mode

For more details, see the [ESP32-C3 Technical Reference Manual](#) > Chapter *SHA Accelerator (SHA)*.

4.1.4.5 Digital Signature

The Digital Signature (DS) module in the ESP32-C3 chip generates message signatures based on RSA with hardware acceleration.

Feature List

- RSA digital signatures with key length up to 3072 bits
- Encrypted private key data, only decryptable by DS module
- SHA-256 digest to protect private key data against tampering by an attacker

For more details, see the [ESP32-C3 Technical Reference Manual](#) > Chapter *Digital Signature (DS)*.

4.1.4.6 External Memory Encryption and Decryption

The External Memory Encryption and Decryption (XTS_AES) module in the ESP32-C3 chip provides security for users' application code and data stored in the external memory (flash).

Feature List

- General XTS_AES algorithm, compliant with IEEE Std 1619-2007
- Software-based manual encryption
- High-speed auto decryption, without software's participation
- Encryption and decryption functions jointly determined by registers configuration, eFuse parameters, and boot mode

For more details, see the [ESP32-C3 Technical Reference Manual](#) > Chapter *External Memory Encryption and Decryption (XTS_AES)*.

4.1.4.7 Random Number Generator

The Random Number Generator (RNG) in the ESP32-C3 is a true random number generator that generates 32-bit random numbers for cryptographic operations from a physical process.

Feature List

- RNG entropy source
 - Thermal noise from high-speed ADC or SAR ADC
 - An asynchronous clock mismatch

For more details about the Random Number Generator, refer to the [ESP32-C3 Technical Reference Manual](#) > Chapter *Random Number Generator (RNG)*.

4.1.4.8 Clock Glitch Detection

The Clock Glitch Detection module on ESP32-C3 detects glitches in external crystal clock signals, and generates a system reset signal when detecting glitches to reset the whole digital circuit including RTC.

For more details about the Random Number Generator, refer to the [ESP32-C3 Technical Reference Manual](#) > Chapter *Clock Glitch Detection*.

4.2 Peripherals

This section describes the chip's peripheral capabilities, covering connectivity interfaces and on-chip sensors that extend its functionality.

4.2.1 Connectivity Interface

This subsection describes the connectivity interfaces on the chip that enable communication and interaction with external devices and networks.

4.2.1.1 UART Controller

ESP32-C3 has two UART interfaces, i.e. UART0 and UART1, which support IrDA and asynchronous communication (RS232 and RS485) at a speed of up to 5 Mbps. The UART controller provides hardware flow control (CTS and RTS signals) and software flow control (XON and XOFF). Both UART interfaces connect to GDMA via UHCIO, and can be accessed by the GDMA controller or directly by the CPU.

For details, see [ESP32-C3 Technical Reference Manual](#) > Chapter *UART Controller (UART, LP_UART)*.

Pin Assignment

For details, see Section [2.3.4 Peripheral Pin Assignment](#).

4.2.1.2 SPI Controller

ESP32-C3 has the following SPI interfaces:

- **SPI0** used by ESP32-C3's GDMA controller and cache to access in-package or off-package flash
- **SPI1** used by the CPU to access in-package or off-package flash
- **SPI2** is a general purpose SPI controller with access to a DMA channel allocated by the GDMA controller

Features of SPI0 and SPI1

- Supports Single SPI, Dual SPI, and Quad SPI, QPI modes
- Configurable clock frequency with a maximum of 120 MHz in Single Transfer Rate (STR) mode
- Data transmission is in bytes

Features of SPI2

- Supports operation as a master or slave
- Connects to a DMA channel allocated by the GDMA controller
- Supports Single SPI, Dual SPI, and Quad SPI, QPI
- Configurable clock polarity (CPOL) and phase (CPHA)
- Configurable clock frequency
- Data transmission is in bytes

- Configurable read and write data bit order: most-significant bit (MSB) first, or least-significant bit (LSB) first
- As a master
 - Supports 2-line full-duplex communication with clock frequency up to 80 MHz
 - Supports 1-, 2-, 4-line half-duplex communication with clock frequency up to 80 MHz
 - Provides six SPI_CS pins for connection with six independent SPI slaves
 - Configurable CS setup time and hold time
- As a slave
 - Supports 2-line full-duplex communication with clock frequency up to 60 MHz
 - Supports 1-, 2-, 4-line half-duplex communication with clock frequency up to 60 MHz

For details, see [ESP32-C3 Technical Reference Manual](#) > Chapter *SPI Controller (SPI)*.

Pin Assignment

For details, see Section [2.3.4 Peripheral Pin Assignment](#).

4.2.1.3 I2C Controller

ESP32-C3 has an I2C bus interface which is used for I2C master mode or slave mode, depending on your configuration. The I2C interface supports:

- Standard mode (100 Kbit/s)
- Fast mode (400 Kbit/s)
- Up to 800 Kbit/s (constrained by SCL and SDA pull-up strength)
- 7-bit and 10-bit addressing mode
- Double addressing mode
- 7-bit broadcast address

For details, see [ESP32-C3 Technical Reference Manual](#) > Chapter *I2C Controller (I2C)*.

Pin Assignment

For details, see Section [2.3.4 Peripheral Pin Assignment](#).

4.2.1.4 I2S Controller

ESP32-C3 includes a standard I2S interface. This interface can operate as a master or a slave in full-duplex mode or half-duplex mode, and can be configured for 8-bit, 16-bit, 24-bit, or 32-bit serial communication. BCK clock frequency, from 10 kHz up to 40 MHz, is supported.

The I2S interface connects to the GDMA controller. The interface supports TDM PCM, TDM MSB alignment, TDM standard, and PDM standard.

For details, see [ESP32-C3 Technical Reference Manual](#) > Chapter *I2S Controller (I2S)*.

Pin Assignment

For details, see Section [2.3.4 Peripheral Pin Assignment](#).

4.2.1.5 USB Serial/JTAG Controller

ESP32-C3 integrates a USB Serial/JTAG controller. This controller has the following features:

- CDC-ACM virtual serial port and JTAG adapter functionality
- USB 2.0 full speed compliant, capable of up to 12 Mbit/s transfer speed (Note that this controller does not support the faster 480 Mbit/s high-speed transfer mode)
- Programming in-package/off-package flash
- CPU debugging with compact JTAG instructions
- A full-speed USB PHY integrated in the chip

For details, see [ESP32-C3 Technical Reference Manual](#) > Chapter *USB Serial/JTAG Controller (USB_SERIAL_JTAG)*.

Pin Assignment

For details, see Section [2.3.4 Peripheral Pin Assignment](#).

4.2.1.6 Two-wire Automotive Interface

ESP32-C3 has a TWAI[®] controller with the following features:

- Compatible with ISO 11898-1 protocol (CAN Specification 2.0)
- Standard frame format (11-bit ID) and extended frame format (29-bit ID)
- Bit rates from 1 Kbit/s to 1 Mbit/s
- Multiple modes of operation: Normal, Listen Only, and Self-Test (no acknowledgment required)
- 64-byte receive FIFO
- Acceptance filter (single and dual filter modes)
- Error detection and handling: error counters, configurable error interrupt threshold, error code capture, arbitration lost capture

For details, see [ESP32-C3 Technical Reference Manual](#) > Chapter *Two-wire Automotive Interface*.

Pin Assignment

For details, see Section [2.3.4 Peripheral Pin Assignment](#).

4.2.1.7 LED PWM Controller

The LED PWM controller can generate independent digital waveform on six channels. The LED PWM controller:

- Can generate digital waveform with configurable periods and duty cycle. The resolution of duty cycle can be up to 14 bits.
- Has multiple clock sources, including APB clock and external main crystal clock.
- Can operate when the CPU is in Light-sleep mode.
- Supports gradual increase or decrease of duty cycle, which is useful for the LED RGB color-gradient generator.

For details, see [ESP32-C3 Technical Reference Manual](#) > Chapter *LED PWM Controller*.

Pin Assignment

For details, see Section [2.3.4 Peripheral Pin Assignment](#).

4.2.1.8 Remote Control Peripheral

The Remote Control Peripheral (RMT) supports two channels of infrared remote transmission and two channels of infrared remote reception. By controlling pulse waveform through software, it supports various infrared and other single wire protocols. All four channels share a 192 × 32-bit memory block to store transmit or receive waveform.

For more details, see [ESP32-C3 Technical Reference Manual](#) > Chapter *Remote Control Peripheral (RMT)*.

Pin Assignment

For details, see Section [2.3.4 Peripheral Pin Assignment](#).

4.2.2 Analog Signal Processing

This subsection describes components on the chip that sense and process real-world data.

4.2.2.1 SAR ADC

ESP32-C3 integrates two 12-bit SAR ADCs.

- ADC1 supports measurements on 5 channels, and is factory-calibrated.
- ADC2 supports measurements on 1 channel, and is not factory-calibrated.

Note:

ADC2 of some chip revisions is not operable. For details, please refer to [ESP32-C3 Series SoC Errata](#).

For ADC characteristics, please refer to Section [5.5 ADC Characteristics](#).

For more details, see [ESP32-C3 Technical Reference Manual](#) > Chapter *On-Chip Sensors and Analog Signal Processing*.

Pin Assignment

For details, see Section [2.3.4 Peripheral Pin Assignment](#).

4.2.2.2 Temperature Sensor

The temperature sensor generates a voltage that varies with temperature. The voltage is internally converted via an ADC into a digital value.

The temperature sensor has a range of $-40\text{ }^{\circ}\text{C}$ to $125\text{ }^{\circ}\text{C}$. It is designed primarily to sense the temperature changes inside the chip. The temperature value depends on factors like microcontroller clock frequency or I/O load. Generally, the chip's internal temperature is higher than the operating ambient temperature.

For more details, see [ESP32-C3 Technical Reference Manual](#) > Chapter *On-Chip Sensors and Analog Signal Processing*.

4.3 Wireless Communication

This section describes the chip's wireless communication capabilities, spanning radio technology, Wi-Fi, Bluetooth, and 802.15.4.

4.3.1 Radio

This subsection describes the fundamental radio technology embedded in the chip that facilitates wireless communication and data exchange. ESP32-C3 radio consists of the following blocks:

- 2.4 GHz receiver
- 2.4 GHz transmitter
- Bias and regulators
- Balun and transmit-receive switch
- Clock generator

4.3.1.1 2.4 GHz Receiver

The 2.4 GHz receiver demodulates the 2.4 GHz RF signal to quadrature baseband signals and converts them to the digital domain with two high-resolution, high-speed ADCs. To adapt to varying signal channel conditions, ESP32-C3 integrates RF filters, Automatic Gain Control (AGC), DC offset cancelation circuits, and baseband filters.

4.3.1.2 2.4 GHz Transmitter

The 2.4 GHz transmitter modulates the quadrature baseband signals to the 2.4 GHz RF signal, and drives the antenna with a high-powered CMOS power amplifier. The use of digital calibration further improves the linearity of the power amplifier.

Additional calibrations are integrated to cancel any radio imperfections, such as:

- Carrier leakage
- I/Q amplitude/phase matching
- Baseband nonlinearities
- RF nonlinearities
- Antenna matching

These built-in calibration routines reduce the cost, time, and specialized equipment required for product testing.

4.3.1.3 Clock Generator

The clock generator produces quadrature clock signals of 2.4 GHz for both the receiver and the transmitter. All components of the clock generator are integrated into the chip, including inductors, varactors, filters, regulators and dividers.

The clock generator has built-in calibration and self-test circuits. Quadrature clock phases and phase noise are optimized on chip with patented calibration algorithms which ensure the best performance of the receiver and the transmitter.

4.3.2 Wi-Fi

This subsection describes the chip's Wi-Fi capabilities, which facilitate wireless communication at a high data rate.

4.3.2.1 Wi-Fi Radio and Baseband

ESP32-C3 Wi-Fi radio and baseband support the following features:

- 802.11b/g/n
- 802.11n MCS0-7 that supports 20 MHz and 40 MHz bandwidth
- 802.11n MCS32
- 802.11n 0.4 μ s guard interval
- Data rate up to 150 Mbps
- RX STBC (single spatial stream)
- Adjustable transmitting power
- Antenna diversity

ESP32-C3 supports antenna diversity with an external RF switch. This switch is controlled by one or more GPIOs, and used to select the best antenna to minimize the effects of channel imperfections.

4.3.2.2 Wi-Fi MAC

ESP32-C3 implements the full 802.11 b/g/n Wi-Fi MAC protocol. It supports the Basic Service Set (BSS) STA and SoftAP operations under the Distributed Control Function (DCF). Power management is handled automatically with minimal host interaction to minimize the active duty period.

ESP32-C3 Wi-Fi MAC applies the following low-level protocol functions automatically:

- 4 \times Virtual Wi-Fi interfaces
- Infrastructure BSS in Station mode, SoftAP mode, Station + SoftAP mode, and promiscuous mode
- RTS protection, CTS protection, Immediate Block ACK
- Fragmentation and defragmentation
- TX/RX A-MPDU, TX/RX A-MSDU
- Transmit opportunity (TXOP)
- Wi-Fi multimedia (WMM)
- GCMP, CCMP, TKIP, WAPI, WEP, BIP, WPA2-PSK/WPA2-Enterprise, and WPA3-PSK/WPA3-Enterprise
- Automatic beacon monitoring (hardware TSF)
- 802.11mc FTM

4.3.2.3 Networking Features

Espressif provides libraries for TCP/IP networking, ESP-WIFI-MESH networking, and other networking protocols over Wi-Fi. TLS 1.0, 1.1 and 1.2 is also supported.

4.3.3 Bluetooth LE

This subsection describes the chip's Bluetooth capabilities, which facilitate wireless communication for low-power, short-range applications. ESP32-C3 includes a Bluetooth Low Energy subsystem that integrates a hardware link layer controller, an RF/modem block and a feature-rich software protocol stack. It supports the core features of Bluetooth 5 and Bluetooth mesh.

4.3.3.1 Bluetooth LE PHY

Bluetooth Low Energy radio and PHY in ESP32-C3 support:

- 1 Mbps PHY
- 2 Mbps PHY for higher data rates
- Coded PHY for longer range (125 Kbps and 500 Kbps)
- HW Listen before talk (LBT)

4.3.3.2 Bluetooth LE Link Controller

Bluetooth Low Energy Link Layer Controller in ESP32-C3 supports:

- LE Advertising Extensions, to enhance broadcasting capacity and broadcast more intelligent data
- Multiple advertising sets
- Simultaneous advertising and scanning
- Multiple connections in simultaneous central and peripheral roles
- Adaptive Frequency Hopping (AFH) and channel assessment
- LE Channel Selection Algorithm #2
- Connection parameter update
- High Duty Cycle Non-Connectable Advertising
- LE privacy 1.2
- LE Data Packet Length Extension
- Link Layer Extended Scanner Filter policies
- Low duty cycle directed advertising
- Link layer encryption
- LE Ping

5 Electrical Characteristics

5.1 Absolute Maximum Ratings

Stresses above those listed in Table 5-1 *Absolute Maximum Ratings* may cause permanent damage to the device. These are stress ratings only and normal operation of the device at these or any other conditions beyond those indicated in Section 5.2 *Recommended Operating Conditions* is not implied. Exposure to absolute-maximum-rated conditions for extended periods may affect device reliability.

Table 5-1. Absolute Maximum Ratings

Parameter	Description	Min	Max	Unit
Input power pins ¹	Allowed input voltage	-0.3	3.6	V
I_{output} ²	Cumulative IO output current	—	1000	mA
T_{STORE}	Storage temperature	-40	150	°C

¹ For more information on input power pins, see Section 2.5 *Power Supply*.

² The product proved to be fully functional after all its IO pins were pulled high while being connected to ground for 24 consecutive hours at ambient temperature of 25 °C.

5.2 Recommended Operating Conditions

For recommended ambient temperature, see Section 1 *ESP32-C3 Series Comparison*.

Table 5-2. Recommended Operating Conditions

Parameter ¹	Description	Min	Typ	Max	Unit
VDDA, VDD3P3, VDD3P3_RTC	Recommended input voltage	3.0	3.3	3.6	V
VDD3P3_CPU ^{2, 3}	Recommended input voltage	3.0	3.3	3.6	V
VDD_SPI (as input)	—	3.0	3.3	3.6	V
I_{VDD}	Cumulative input current	0.5	—	—	A

¹ See in conjunction with Section 2.5 *Power Supply*.

² If writing to eFuses, the voltage on VDD3P3_CPU should not exceed 3.3 V as the circuits responsible for burning eFuses are sensitive to higher voltages.

³ If VDD3P3_CPU is used to power VDD_SPI (see Section 2.5.2 *Power Scheme*), the voltage drop on R_{SPI} should be accounted for. See also Section 5.3 *VDD_SPI Output Characteristics*.

5.3 VDD_SPI Output Characteristics

Table 5-3. VDD_SPI Internal and Output Characteristics

Parameter	Description ¹	Typ	Unit
R_{SPI}	VDD_SPI powered by VDD3P3_CPU via R_{SPI} for 3.3 V flash_CPU ²	7.5	Ω

¹ See in conjunction with Section 2.5.2 *Power Scheme*.

² VDD3P3_CPU must be more than $VDD_flash_min + I_flash_max * R_{SPI}$;

where

- VDD_flash_min – minimum operating voltage of flash_CPU
- I_flash_max – maximum operating current of flash_CPU

5.4 DC Characteristics (3.3 V, 25 °C)

Table 5-4. DC Characteristics (3.3 V, 25 °C)

Parameter	Description	Min	Typ	Max	Unit
C_{IN}	Pin capacitance	–	2	–	pF
V_{IH}	High-level input voltage	$0.75 \times VDD^1$	–	$VDD^1 + 0.3$	V
V_{IL}	Low-level input voltage	–0.3	–	$0.25 \times VDD^1$	V
I_{IH}	High-level input current	–	–	50	nA
I_{IL}	Low-level input current	–	–	50	nA
V_{OH}^2	High-level output voltage	$0.8 \times VDD^1$	–	–	V
V_{OL}^2	Low-level output voltage	–	–	$0.1 \times VDD^1$	V
I_{OH}	High-level source current ($VDD^1 = 3.3$ V, $V_{OH} \geq 2.64$ V, PAD_DRIVER = 3)	–	40	–	mA
I_{OL}	Low-level sink current ($VDD^1 = 3.3$ V, $V_{OL} = 0.495$ V, PAD_DRIVER = 3)	–	28	–	mA
R_{PU}	Internal weak pull-up resistor	–	45	–	k Ω
R_{PD}	Internal weak pull-down resistor	–	45	–	k Ω
V_{IH_nRST}	Chip reset release voltage (CHIP_EN voltage is within the specified range)	$0.75 \times VDD^1$	–	$VDD^1 + 0.3$	V
V_{IL_nRST}	Chip reset voltage (CHIP_EN voltage is within the specified range)	–0.3	–	$0.25 \times VDD^1$	V

¹ VDD – voltage from a power pin of a respective power domain.

² V_{OH} and V_{OL} are measured using high-impedance load.

5.5 ADC Characteristics

Table 5-5. ADC Characteristics

Symbol	Parameter	Min	Max	Unit
DNL (Differential nonlinearity) ¹	ADC connected to an external 100 nF capacitor; DC signal input; Ambient temperature at 25 °C; Wi-Fi off	-7	7	LSB
INL (Integral nonlinearity)		-12	12	LSB
Sampling rate	—	—	100	kSPS 2

¹ To get better DNL results, you can sample multiple times and apply a filter, or calculate the average value.

² kSPS means kilo samples-per-second.

The calibrated ADC results after hardware calibration and [software calibration](#) are shown in Table 5-6. For higher accuracy, you may implement your own calibration methods.

Table 5-6. ADC Calibration Results

Parameter	Description	Min	Max	Unit
Total error	ATTEN0, effective measurement range of 0 ~ 750	-10	10	mV
	ATTEN1, effective measurement range of 0 ~ 1050	-10	10	mV
	ATTEN2, effective measurement range of 0 ~ 1300	-10	10	mV
	ATTEN3, effective measurement range of 0 ~ 2500	-35	35	mV

5.6 Current Consumption

5.6.1 RF Current Consumption in Active Mode

The current consumption measurements are taken with a 3.3 V supply at 25 °C of ambient temperature at the RF port. All transmitters' measurements are based on a 100% duty cycle.

Table 5-7. Wi-Fi Current Consumption Depending on RF Modes

Work Mode ¹	Description	Peak (mA)	
Active (RF working)	TX	802.11b, 1 Mbps, @21 dBm	335
		802.11g, 54 Mbps, @19 dBm	285
		802.11n, HT20, MCS7, @18.5 dBm	276
		802.11n, HT40, MCS7, @18.5 dBm	278
	RX	802.11b/g/n, HT20	84
		802.11n, HT40	87

5.6.2 Current Consumption in Other Modes

Table 5-8. Current Consumption in Modem-sleep Mode

Mode	CPU Frequency (MHz)	Description	Typ	
			All Peripherals Clocks Disabled (mA)	All Peripherals Clocks Enabled (mA) ¹
Modem-sleep ^{2,3}	160	CPU is running	23	28
		CPU is idle	16	21
	80	CPU is running	17	22
		CPU is idle	13	18

¹ In practice, the current consumption might be different depending on which peripherals are enabled.

² In Modem-sleep mode, Wi-Fi is clock gated.

³ In Modem-sleep mode, the consumption might be higher when accessing flash. For a flash rated at 80 Mbit/s, in SPI 2-line mode the consumption is 10 mA.

Table 5-9. Current Consumption in Low-Power Modes

Mode	Description	Typ (μ A)
Light-sleep	VDD_SPI and Wi-Fi are powered down, and all GPIOs are high-impedance	130
Deep-sleep	RTC timer + RTC memory	5
Power off	CHIP_EN is set to low level, the chip is powered off	1

5.7 Memory Specifications

The data below is sourced from the memory vendor datasheet. These values are guaranteed through design and/or characterization but are not fully tested in production. Devices are shipped with the memory erased.

Table 5-10. Flash Specifications

Parameter	Description	Min	Typ	Max	Unit
VCC	Power supply voltage (1.8 V)	1.65	1.80	2.00	V
	Power supply voltage (3.3 V)	2.7	3.3	3.6	V
F_C	Maximum clock frequency	80	—	—	MHz
—	Program/erase cycles	100,000	—	—	cycles
T_{RET}	Data retention time	20	—	—	years
T_{PP}	Page program time	—	0.8	5	ms
T_{SE}	Sector erase time (4 KB)	—	70	500	ms
T_{BE1}	Block erase time (32 KB)	—	0.2	2	s
T_{BE2}	Block erase time (64 KB)	—	0.3	3	s
T_{CE}	Chip erase time (16 Mb)	—	7	20	s
	Chip erase time (32 Mb)	—	20	60	s
	Chip erase time (64 Mb)	—	25	100	s
	Chip erase time (128 Mb)	—	60	200	s

Cont'd on next page

Table 5-10 – cont'd from previous page

Parameter	Description	Min	Typ	Max	Unit
	Chip erase time (256 Mb)	–	70	300	s

5.8 Reliability

Table 5-11. Reliability Qualifications

Test Item	Test Conditions	Test Standard
HTOL (High Temperature Operating Life)	125 °C, 1000 hours	JESD22-A108
ESD (Electro-Static Discharge Sensitivity)	HBM (Human Body Mode) ¹ ± 2000 V	JS-001
	CDM (Charge Device Mode) ² ± 1000 V	JS-002
Latch up	Current trigger ± 200 mA	JESD78
	Voltage trigger $1.5 \times VDD_{max}$	
Preconditioning	Bake 24 hours @125 °C Moisture soak (level 3: 192 hours @30 °C, 60% RH) IR reflow solder: 260 + 0 °C, 20 seconds, three times	J-STD-020, JESD47, JESD22-A113
TCT (Temperature Cycling Test)	–65 °C / 150 °C, 500 cycles	JESD22-A104
uHAST (Highly Accelerated Stress Test, unbiased)	130 °C, 85% RH, 96 hours	JESD22-A118
HTSL (High Temperature Storage Life)	150 °C, 1000 hours	JESD22-A103
LTSL (Low Temperature Storage Life)	–40 °C, 1000 hours	JESD22-A119

¹ JEDEC document JEP155 states that 500 V HBM allows safe manufacturing with a standard ESD control process.

² JEDEC document JEP157 states that 250 V CDM allows safe manufacturing with a standard ESD control process.

6 RF Characteristics

This section contains tables with RF characteristics of the Espressif product.

The RF data is measured at the antenna port, where RF cable is connected, including the front-end loss. The front-end circuit is a 0 Ω resistor.

Devices should operate in the center frequency range allocated by regional regulatory authorities. The target center frequency range and the target transmit power are configurable by software. See [ESP RF Test Tool and Test Guide](#) for instructions.

Unless otherwise stated, the RF tests are conducted with a 3.3 V ($\pm 5\%$) supply at 25 °C ambient temperature.

6.1 Wi-Fi Radio

Table 6-1. Wi-Fi Frequency

Parameter	Min (MHz)	Typ (MHz)	Max (MHz)
Center frequency of operating channel	2412	—	2484

6.1.1 Wi-Fi RF Transmitter (TX) Characteristics

Table 6-2. TX Power with Spectral Mask and EVM Meeting 802.11 Standards

Rate	Min (dBm)	Typ (dBm)	Max (dBm)
802.11b, 1 Mbps	—	21.0	—
802.11b, 11 Mbps	—	21.0	—
802.11g, 6 Mbps	—	21.0	—
802.11g, 54 Mbps	—	19.0	—
802.11n, HT20, MCS0	—	20.0	—
802.11n, HT20, MCS7	—	18.5	—
802.11n, HT40, MCS0	—	20.0	—
802.11n, HT40, MCS7	—	18.5	—

Table 6-3. TX EVM Test

Rate	Min (dB)	Typ (dB)	SL ¹ (dB)
802.11b, 1 Mbps, @21 dBm	—	-24.5	-10
802.11b, 11 Mbps, @21 dBm	—	-25.0	-10
802.11g, 6 Mbps, @21 dBm	—	-23.0	-5
802.11g, 54 Mbps, @19 dBm	—	-27.5	-25
802.11n, HT20, MCS0, @20 dBm	—	-22.5	-5

Cont'd on next page

Table 6-3 – cont'd from previous page

Rate	Min (dB)	Typ (dB)	SL ¹ (dB)
802.11n, HT20, MCS7, @18.5 dBm	—	-29.0	-27
802.11n, HT40, MCS0, @20 dBm	—	-22.5	-5
802.11n, HT40, MCS7, @18.5 dBm	—	-28.0	-27

¹ SL stands for standard limit value.

6.1.2 Wi-Fi RF Receiver (RX) Characteristics

Table 6-4. RX Sensitivity

Rate	Min (dBm)	Typ (dBm)	Max (dBm)
802.11b, 1 Mbps	—	-98.4	—
802.11b, 2 Mbps	—	-96.0	—
802.11b, 5.5 Mbps	—	-93.0	—
802.11b, 11 Mbps	—	-88.6	—
802.11g, 6 Mbps	—	-93.8	—
802.11g, 9 Mbps	—	-92.2	—
802.11g, 12 Mbps	—	-91.0	—
802.11g, 18 Mbps	—	-88.4	—
802.11g, 24 Mbps	—	-85.8	—
802.11g, 36 Mbps	—	-82.0	—
802.11g, 48 Mbps	—	-78.0	—
802.11g, 54 Mbps	—	-76.6	—
802.11n, HT20, MCS0	—	-93.6	—
802.11n, HT20, MCS1	—	-90.8	—
802.11n, HT20, MCS2	—	-88.4	—
802.11n, HT20, MCS3	—	-85.0	—
802.11n, HT20, MCS4	—	-81.8	—
802.11n, HT20, MCS5	—	-77.8	—
802.11n, HT20, MCS6	—	-76.0	—
802.11n, HT20, MCS7	—	-74.8	—
802.11n, HT40, MCS0	—	-90.0	—
802.11n, HT40, MCS1	—	-88.0	—
802.11n, HT40, MCS2	—	-85.2	—
802.11n, HT40, MCS3	—	-82.0	—
802.11n, HT40, MCS4	—	-78.8	—
802.11n, HT40, MCS5	—	-74.6	—
802.11n, HT40, MCS6	—	-73.0	—
802.11n, HT40, MCS7	—	-71.4	—

Table 6-5. Maximum RX Level

Rate	Min (dBm)	Typ (dBm)	Max (dBm)
802.11b, 1 Mbps	—	5	—
802.11b, 11 Mbps	—	5	—
802.11g, 6 Mbps	—	5	—
802.11g, 54 Mbps	—	0	—
802.11n, HT20, MCS0	—	5	—
802.11n, HT20, MCS7	—	0	—
802.11n, HT40, MCS0	—	5	—
802.11n, HT40, MCS7	—	0	—

Table 6-6. RX Adjacent Channel Rejection

Rate	Min (dB)	Typ (dB)	Max (dB)
802.11b, 1 Mbps	—	35	—
802.11b, 11 Mbps	—	35	—
802.11g, 6 Mbps	—	31	—
802.11g, 54 Mbps	—	20	—
802.11n, HT20, MCS0	—	31	—
802.11n, HT20, MCS7	—	16	—
802.11n, HT40, MCS0	—	25	—
802.11n, HT40, MCS7	—	11	—

6.2 Bluetooth 5 (LE) Radio

Table 6-7. Bluetooth LE Frequency

Parameter	Min (MHz)	Typ (MHz)	Max (MHz)
Center frequency of operating channel	2402	—	2480

6.2.1 Bluetooth LE RF Transmitter (TX) Characteristics

Table 6-8. Transmitter Characteristics - Bluetooth LE 1 Mbps

Parameter	Description	Min	Typ	Max	Unit
RF transmit power	RF power control range	-24.00	0	20.00	dBm
	Gain control step	—	3.00	—	dB
Carrier frequency offset and drift	$\text{Max } f_n _{n=0, 1, 2, \dots, k}$	—	17.00	—	kHz
	$\text{Max } f_0 - f_n $	—	1.75	—	kHz
	$\text{Max } f_n - f_{n-5} $	—	1.46	—	kHz

Cont'd on next page

Table 6-8 – cont'd from previous page

Parameter	Description	Min	Typ	Max	Unit
	$ f_1 - f_0 $	—	0.80	—	kHz
Modulation characteristics	$\Delta f_{1_{avg}}$	—	250.00	—	kHz
	Min $\Delta f_{2_{max}}$ (for at least 99.9% of all $\Delta f_{2_{max}}$)	—	190.00	—	kHz
	$\Delta f_{2_{avg}}/\Delta f_{1_{avg}}$	—	0.83	—	—
In-band spurious emissions	± 2 MHz offset	—	-37.62	—	dBm
	± 3 MHz offset	—	-41.95	—	dBm
	$> \pm 3$ MHz offset	—	-44.48	—	dBm

Table 6-9. Transmitter Characteristics - Bluetooth LE 2 Mbps

Parameter	Description	Min	Typ	Max	Unit
RF transmit power	RF power control range	-24.00	0	20.00	dBm
	Gain control step	—	3.00	—	dB
Carrier frequency offset and drift	Max $ f_n _{n=0, 1, 2, \dots, k}$	—	20.80	—	kHz
	Max $ f_0 - f_n $	—	1.30	—	kHz
	Max $ f_n - f_{n-5} $	—	1.33	—	kHz
	$ f_1 - f_0 $	—	0.70	—	kHz
Modulation characteristics	$\Delta f_{1_{avg}}$	—	498.00	—	kHz
	Min $\Delta f_{2_{max}}$ (for at least 99.9% of all $\Delta f_{2_{max}}$)	—	430.00	—	kHz
	$\Delta f_{2_{avg}}/\Delta f_{1_{avg}}$	—	0.93	—	—
In-band spurious emissions	± 4 MHz offset	—	-43.55	—	dBm
	± 5 MHz offset	—	-45.26	—	dBm
	$> \pm 5$ MHz offset	—	-45.26	—	dBm

Table 6-10. Transmitter Characteristics - Bluetooth LE 125 Kbps

Parameter	Description	Min	Typ	Max	Unit
RF transmit power	RF power control range	-24.00	0	20.00	dBm
	Gain control step	—	3.00	—	dB
Carrier frequency offset and drift	Max $ f_n _{n=0, 1, 2, \dots, k}$	—	17.50	—	kHz
	Max $ f_0 - f_n $	—	0.45	—	kHz
	$ f_n - f_{n-3} $	—	0.70	—	kHz
	$ f_0 - f_3 $	—	0.30	—	kHz
Modulation characteristics	$\Delta f_{1_{avg}}$	—	250.00	—	kHz
	Min $\Delta f_{1_{max}}$ (for at least 99.9% of all $\Delta f_{2_{max}}$)	—	235.00	—	kHz
In-band spurious emissions	± 2 MHz offset	—	-37.90	—	dBm
	± 3 MHz offset	—	-41.00	—	dBm
	$> \pm 3$ MHz offset	—	-42.50	—	dBm

Table 6-11. Transmitter Characteristics - Bluetooth LE 500 Kbps

Parameter	Description	Min	Typ	Max	Unit
RF transmit power	RF power control range	-24.00	0	20.00	dBm
	Gain control step	—	3.00	—	dB
Carrier frequency offset and drift	$\text{Max } f_n _{n=0, 1, 2, \dots, k}$	—	17.00	—	kHz
	$\text{Max } f_0 - f_n $	—	0.88	—	kHz
	$ f_n - f_{n-3} $	—	1.00	—	kHz
	$ f_0 - f_3 $	—	0.20	—	kHz
Modulation characteristics	$\Delta f_{2_{\text{avg}}}$	—	208.00	—	kHz
	Min $\Delta f_{2_{\text{max}}}$ (for at least 99.9% of all $\Delta f_{2_{\text{max}}}$)	—	190.00	—	kHz
In-band spurious emissions	± 2 MHz offset	—	-37.90	—	dBm
	± 3 MHz offset	—	-41.30	—	dBm
	$> \pm 3$ MHz offset	—	-42.80	—	dBm

6.2.2 Bluetooth LE RF Receiver (RX) Characteristics

Table 6-12. Receiver Characteristics - Bluetooth LE 1 Mbps

Parameter	Description	Min	Typ	Max	Unit
Sensitivity @30.8% PER	—	—	-97	—	dBm
Maximum received signal @30.8% PER	—	—	5	—	dBm
Co-channel C/I	—	—	8	—	dB
Adjacent channel selectivity C/I	$F = F_0 + 1 \text{ MHz}$	—	-3	—	dB
	$F = F_0 - 1 \text{ MHz}$	—	-4	—	dB
	$F = F_0 + 2 \text{ MHz}$	—	-29	—	dB
	$F = F_0 - 2 \text{ MHz}$	—	-31	—	dB
	$F = F_0 + 3 \text{ MHz}$	—	-33	—	dB
	$F = F_0 - 3 \text{ MHz}$	—	-27	—	dB
	$F \geq F_0 + 4 \text{ MHz}$	—	-29	—	dB
$F \leq F_0 - 4 \text{ MHz}$	—	—	-38	—	dB
Image frequency	—	—	-29	—	dB
Adjacent channel to image frequency	$F = F_{\text{image}} + 1 \text{ MHz}$	—	-41	—	dB
	$F = F_{\text{image}} - 1 \text{ MHz}$	—	-33	—	dB
Out-of-band blocking performance	30 MHz ~ 2000 MHz	—	-5	—	dBm
	2003 MHz ~ 2399 MHz	—	-18	—	dBm
	2484 MHz ~ 2997 MHz	—	-15	—	dBm
	3000 MHz ~ 12.75 GHz	—	-5	—	dBm
Intermodulation	—	—	-30	—	dBm

Table 6-13. Receiver Characteristics - Bluetooth LE 2 Mbps

Parameter	Description	Min	Typ	Max	Unit
Sensitivity @30.8% PER	—	—	-93	—	dBm
Maximum received signal @30.8% PER	—	—	3	—	dBm
Co-channel C/I	—	—	10	—	dB
Adjacent channel selectivity C/I	$F = F_0 + 2 \text{ MHz}$	—	-7	—	dB
	$F = F_0 - 2 \text{ MHz}$	—	-7	—	dB
	$F = F_0 + 4 \text{ MHz}$	—	-28	—	dB
	$F = F_0 - 4 \text{ MHz}$	—	-26	—	dB
	$F = F_0 + 6 \text{ MHz}$	—	-26	—	dB
	$F = F_0 - 6 \text{ MHz}$	—	-27	—	dB
	$F \geq F_0 + 8 \text{ MHz}$	—	-29	—	dB
	$F \leq F_0 - 8 \text{ MHz}$	—	-28	—	dB
Image frequency	—	—	-28	—	dB
Adjacent channel to image frequency	$F = F_{image} + 2 \text{ MHz}$	—	-26	—	dB
	$F = F_{image} - 2 \text{ MHz}$	—	-7	—	dB
Out-of-band blocking performance	30 MHz ~ 2000 MHz	—	-5	—	dBm
	2003 MHz ~ 2399 MHz	—	-19	—	dBm
	2484 MHz ~ 2997 MHz	—	-16	—	dBm
	3000 MHz ~ 12.75 GHz	—	-5	—	dBm
Intermodulation	—	—	-29	—	dBm

Table 6-14. Receiver Characteristics - Bluetooth LE 125 Kbps

Parameter	Description	Min	Typ	Max	Unit
Sensitivity @30.8% PER	—	—	-105	—	dBm
Maximum received signal @30.8% PER	—	—	5	—	dBm
Co-channel C/I	—	—	3	—	dB
Adjacent channel selectivity C/I	$F = F_0 + 1 \text{ MHz}$	—	-6	—	dB
	$F = F_0 - 1 \text{ MHz}$	—	-6	—	dB
	$F = F_0 + 2 \text{ MHz}$	—	-33	—	dB
	$F = F_0 - 2 \text{ MHz}$	—	-43	—	dB
	$F = F_0 + 3 \text{ MHz}$	—	-37	—	dB
	$F = F_0 - 3 \text{ MHz}$	—	-47	—	dB
	$F \geq F_0 + 4 \text{ MHz}$	—	-40	—	dB
	$F \leq F_0 - 4 \text{ MHz}$	—	-50	—	dB
Image frequency	—	—	-40	—	dB
Adjacent channel to image frequency	$F = F_{image} + 1 \text{ MHz}$	—	-50	—	dB
	$F = F_{image} - 1 \text{ MHz}$	—	-37	—	dB

Table 6-15. Receiver Characteristics - Bluetooth LE 500 Kbps

Parameter	Description	Min	Typ	Max	Unit
Sensitivity @30.8% PER	—	—	-100	—	dBm
Maximum received signal @30.8% PER	—	—	5	—	dBm
Co-channel C/I	—	—	3	—	dB
Adjacent channel selectivity C/I	$F = F_0 + 1 \text{ MHz}$	—	-2	—	dB
	$F = F_0 - 1 \text{ MHz}$	—	-3	—	dB
	$F = F_0 + 2 \text{ MHz}$	—	-32	—	dB
	$F = F_0 - 2 \text{ MHz}$	—	-33	—	dB
	$F = F_0 + 3 \text{ MHz}$	—	-23	—	dB
	$F = F_0 - 3 \text{ MHz}$	—	-40	—	dB
	$F \geq F_0 + 4 \text{ MHz}$	—	-34	—	dB
	$F \leq F_0 - 4 \text{ MHz}$	—	-44	—	dB
Image frequency	—	—	-34	—	dB
Adjacent channel to image frequency	$F = F_{image} + 1 \text{ MHz}$	—	-46	—	dB
	$F = F_{image} - 1 \text{ MHz}$	—	-23	—	dB

7 Packaging

- For information about tape, reel, and chip marking, please refer to [ESP32-C3 Chip Packaging Information](#).
- The pins of the chip are numbered in anti-clockwise order starting from Pin 1 in the top view. For pin numbers and pin names, see also Figure 2-1 *Pin Layout (Top View) for ESP32-C3, ESP32-C3FH4, ESP32-C3FN4, and ESP32-C3FH8X*.
- The recommended land pattern [source file \(dxf\)](#) is available for download. You can view the file with [Autodesk Viewer](#).
- For reference PCB layout, please refer to [ESP32-C3 Hardware Design Guidelines](#).

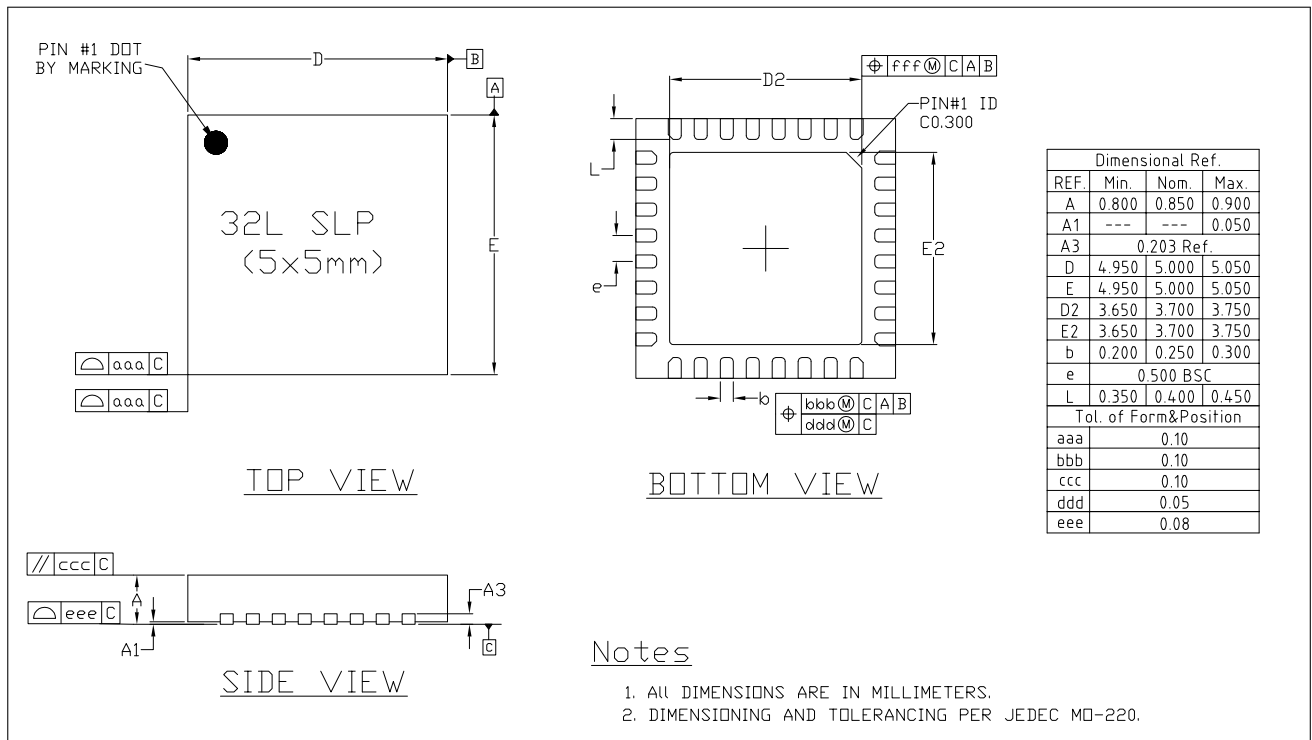

Figure 7-1. QFN32 (5x5 mm) Package

ESP32-C3 Consolidated Pin Overview

Pin No.	Pin Name	Pin Type	Pin Providing Power	Pin Settings		Analog Function		T
				At Reset	After Reset	0	1	
1	LNA_IN	Analog						0
2	VDD3P3	Power						
3	VDD3P3	Power						
4	XTAL_32K_P	IO	VDD3P3_RTC			XTAL_32K_P	ADC1_CH0	GPIO0
5	XTAL_32K_N	IO	VDD3P3_RTC			XTAL_32K_N	ADC1_CH1	GPIO1
6	GPIO2	IO	VDD3P3_RTC	IE	IE		ADC1_CH2	GPIO2
7	CHIP_EN	Analog						
8	GPIO3	IO	VDD3P3_RTC	IE	IE		ADC1_CH3	GPIO3
9	MTMS	IO	VDD3P3_RTC		IE		ADC1_CH4	MTMS
10	MTDI	IO	VDD3P3_RTC		IE		ADC2_CH0	MTDI
11	VDD3P3_RTC	Power						
12	MTCK	IO	VDD3P3_CPU		IE			MTCK
13	MTDO	IO	VDD3P3_CPU		IE			MTDO
14	GPIO8	IO	VDD3P3_CPU	IE	IE			GPIO8
15	GPIO9	IO	VDD3P3_CPU	IE, WPU	IE, WPU			GPIO9
16	GPIO10	IO	VDD3P3_CPU		IE			GPIO10
17	VDD3P3_CPU	Power						
18	VDD_SPI	Power	VDD3P3_CPU					GPIO11
19	SPIHD	IO	VDD_SPI / VDD3P3_CPU	WPU	IE, WPU			SPIHD
20	SPIWP	IO	VDD_SPI / VDD3P3_CPU	WPU	IE, WPU			SPIWP
21	SPICS0	IO	VDD_SPI / VDD3P3_CPU	WPU	IE, WPU			SPICS0
22	SPICLK	IO	VDD_SPI / VDD3P3_CPU	WPU	IE, WPU			SPICLK
23	SPIID	IO	VDD_SPI / VDD3P3_CPU	WPU	IE, WPU			SPIID
24	SPIQ	IO	VDD_SPI / VDD3P3_CPU	WPU	IE, WPU			SPIQ
25	GPIO18	IO	VDD3P3_CPU			USB_D-		GPIO18
26	GPIO19	IO	VDD3P3_CPU			USB_D+		GPIO19
27	UORXD	IO	VDD3P3_CPU		IE, WPU			UORXD
28	UOTXD	IO	VDD3P3_CPU		WPU			UOTXD
29	XTAL_N	Analog						
30	XTAL_P	Analog						
31	VDDA	Power						
32	VDDA	Power						
33	GND	Power						

* For details, see Section 2 Pins. Regarding highlighted cells, see Section 2.3.3 Restrictions for GPIOs.

ESP32-C3 Chip Series Group Overview

The ESP32-C3 [chip series group](#) is a low-power solution that provides 2.4 GHz Wi-Fi (802.11b/g/n) and Bluetooth 5.0 connectivity, dedicated to smart home applications. This chip series group consists of the following [chip series](#):

- ESP32-C3 series
- ESP8685 series, a cost-down version of ESP32-C3 series

All members within the ESP32-C3 chip series group use a common set of software and reference materials, including the technical reference manual and hardware design guidelines – See [Related Documentation and Resources](#).

	ESP32-C3	ESP8685
Chip revision	v0.4/v1.1	v0.4
In-package flash	No/4 MB/8 MB	4 MB
Flash extensibility	Y	—
GPIO count	16 or 22	15
Package	QFN32 (5×5 mm)	QFN28 (4×4 mm)

Datasheet Versioning

Datasheet Version	Status	Watermark	Definition
v0.1 ~ v0.5 (excluding v0.5)	Draft	Confidential	This datasheet is under development for products in the design stage. Specifications may change without prior notice.
v0.5 ~ v1.0 (excluding v1.0)	Preliminary release	Preliminary	This datasheet is actively updated for products in the verification stage. Specifications may change before mass production, and the changes will be documented in the datasheet's Revision History.
v1.0 and higher	Official release	—	This datasheet is publicly released for products in mass production. Specifications are finalized, and major changes will be communicated via Product Change Notifications (PCN) .
Any version	—	Not Recommended for New Design (NRND) ¹	This datasheet is updated less frequently for products not recommended for new designs.
Any version	—	End of Life (EOL) ²	This datasheet is no longer maintained for products that have reached end of life.

¹ Watermark will be added to the datasheet title page only when all the product variants covered by this datasheet are not recommended for new designs.

² Watermark will be added to the datasheet title page only when all the product variants covered by this datasheet have reached end of life.

Glossary

chip series

A subset of chips within a chip series group with similar core features and specifications [2](#), [68](#)

chip series group

A broad group of related chip products that use the same die. For example, ESP32-C3 chip series group consists of ESP32-C3 chip series and ESP8685 chip series [2](#), [68](#)

in-package flash

Flash integrated directly into the chip's package, and external to the chip die [4](#), [35](#)

off-package flash

Flash external to the chip's package [4](#)

peripheral

A hardware component or subsystem within the chip to interface with the outside world [16](#), [19](#)

strapping pin

A type of GPIO pin used to configure certain operational settings during the chip's power-up, and can be reconfigured as normal GPIO after the chip's reset [30](#)

eFuse parameter

A parameter stored in an electrically programmable fuse (eFuse) memory within a chip. The parameter can be set by programming EFUSE_PGM_DATA n _REG registers, and read by reading a register field named after the parameter [30](#)

SPI boot mode

A boot mode in which users load and execute the existing code from SPI flash [31](#)

joint download boot mode

A boot mode in which users can download code into flash via the UART or other interfaces (see [Table 3-3 Chip Boot Mode Control](#) > Note), and load and execute the downloaded code from the flash or SRAM [31](#)

eFuse

A one-time programmable (OTP) memory which stores system and user parameters, such as MAC address, chip revision number, flash encryption key, etc. Value 0 indicates the default state, and value 1 indicates the eFuse has been programmed [35](#)

Related Documentation and Resources

Related Documentation

- [ESP32-C3 Technical Reference Manual](#) – Detailed information on how to use the ESP32-C3 memory and peripherals.
- [ESP32-C3 Hardware Design Guidelines](#) – Guidelines on how to integrate the ESP32-C3 into your hardware product.
- [ESP32-C3 Series SoC Errata](#) – Descriptions of known errors in ESP32-C3 series of SoCs.
- [Certificates](#)
<https://espressif.com/en/support/documents/certificates>
- [ESP32-C3 Product/Process Change Notifications \(PCN\)](#)
<https://espressif.com/en/support/documents/pcns?keys=ESP32-C3>
- [ESP32-C3 Advisories](#) – Information on security, bugs, compatibility, component reliability.
<https://espressif.com/en/support/documents/advisories?keys=ESP32-C3>
- [Documentation Updates and Update Notification Subscription](#)
<https://espressif.com/en/support/download/documents>

Developer Zone

- [ESP-IDF Programming Guide for ESP32-C3](#) – Extensive documentation for the ESP-IDF development framework.
- [ESP-IDF](#) and other development frameworks on GitHub.
<https://github.com/espressif>
- [ESP32 BBS Forum](#) – Engineer-to-Engineer (E2E) Community for Espressif products where you can post questions, share knowledge, explore ideas, and help solve problems with fellow engineers.
<https://esp32.com/>
- [ESP-FAQ](#) – A summary document of frequently asked questions released by Espressif.
<https://espressif.com/projects/esp-faq/en/latest/index.html>
- [The ESP Journal](#) – Best Practices, Articles, and Notes from Espressif folks.
<https://blog.espressif.com/>
- See the tabs [SDKs and Demos](#), [Apps](#), [Tools](#), [AT Firmware](#).
<https://espressif.com/en/support/download/sdks-demos>

Products

- [ESP32-C3 Series SoCs](#) – Browse through all ESP32-C3 SoCs.
<https://espressif.com/en/products/socs?id=ESP32-C3>
- [ESP32-C3 Series Modules](#) – Browse through all ESP32-C3-based modules.
<https://espressif.com/en/products/modules?id=ESP32-C3>
- [ESP32-C3 Series DevKits](#) – Browse through all ESP32-C3-based devkits.
<https://espressif.com/en/products/devkits?id=ESP32-C3>
- [ESP Product Selector](#) – Find an Espressif hardware product suitable for your needs by comparing or applying filters.
<https://products.espressif.com/#/product-selector?language=en>

Contact Us

- See the tabs [Sales Questions](#), [Technical Enquiries](#), [Circuit Schematic & PCB Design Review](#), [Get Samples](#) (Online stores), [Become Our Supplier](#), [Comments & Suggestions](#).
<https://espressif.com/en/contact-us/sales-questions>

Revision History

Date	Version	Release notes
2025-12-24	v2.3	<ul style="list-style-type: none"> Added chip variant ESP32-C3FH8X, see Chapter 1 ESP32-C3 Series Comparison Updated "Ordering Code" to "Part Number" in Table 1-1 ESP32-C3 Series Comparison Added descriptions for the following modules in Chapter 4 Functional Description: <ul style="list-style-type: none"> XTAL32K Watchdog Timers (XTWDT) World Controller (WCL) Clock Glitch Detection
2025-09-04	v2.2	<ul style="list-style-type: none"> Added Section 1.3 Chip Revision 2.3.4 Peripheral Pin Assignment: Updated descriptions; added a note about USB pin swapping to the table Updated Figure 3-1 Visualization of Timing Parameters for the Strapping Pins Added Section 5.7 Memory Specifications Added Appendix Datasheet Versioning Other minor updates
2025-04-14	v2.1	<ul style="list-style-type: none"> Updated CPU CoreMark® score in Section Product Overview According to updates in Compatibility Advisory for ESP32-C3 Chip Revision v1.1, updated SRAM space in note 5 for Table ESP32-C3 Series Comparison
2024-11-14	v2.0	<ul style="list-style-type: none"> Added Section 2.3.4 Peripheral Pin Assignment Added ESP32-C3 Chip Series Group Overview Added Glossary
2024-09-11	v1.9	Updated pin layout and the number of GPIOs for ESP32-C3FH4X according to PCN20240702 Upgrade of ESP32-C3FH4X Product

Cont'd on next page

Cont'd from previous page

Date	Version	Release notes
2024-07-29	v1.8	<ul style="list-style-type: none"> • Removed the ESP32-C3FH4XAZ variant and added Compatibility Advisory for ESP32-C3 Chip Revision v1.1 in Chapter 1 ESP32-C3 Series Comparison • Updated the default driving strength for each pin in Table 2-1 Pin Overview > Note 4 • Added flash erase cycles, retention time, maximum clock frequency in Section 4.1.2.1 Internal Memory • Improved the formatting, structure, and wording in the following sections: <ul style="list-style-type: none"> – Section 2 Pins – Section 3 Boot Configurations (used to be named as "Strapping Pins") – Section 4 Functional Description • Other minor updates
2024-04-01	v1.7	<ul style="list-style-type: none"> • Marked the ESP32-C3FN4 variant as end of life • Marked the ESP32-C3FH4AZ variant as NRND • Marked the ESP32-C3FH4X variant as recommended
2024-01-19	v1.6	<ul style="list-style-type: none"> • Added the new ESP32-C3FH4X and ESP32-C3FH4XAZ variants in Chapter 1 ESP32-C3 Series Comparison • Corrected the PWM duty resolution to 14 bits in Section 4.2.1.7 LED PWM Controller
2023-08-11	v1.5	<ul style="list-style-type: none"> • Marked ESP32-C3FN4 as NRND • Improved the content in the following sections: <ul style="list-style-type: none"> – Section Product Overview – Section 2 Pins – Section 4.1.3.6 Power Management Unit – Section 4.2.1.2 SPI Controller – Section 5.1 Absolute Maximum Ratings – Section 5.2 Recommended Operating Conditions – Section 5.3 VDD_SPI Output Characteristics – Section 5.5 ADC Characteristics • Added Appendix A • Updated the maximum value of "RF power control range" to 20 dBm in Section 6.2 Bluetooth 5 (LE) Radio • Other minor updates

Cont'd on next page

Cont'd from previous page

Date	Version	Release notes
2022-12-15	v1.4	<ul style="list-style-type: none"> Deleted feature "Antenna diversity" from Section 4.3.3.1 Bluetooth LE PHY Deleted feature "Supports external power amplifier" Updated the glitch type of GPIO18 to high-level glitch in Table Power-Up Glitches on Pins
2022-11-15	v1.3	<ul style="list-style-type: none"> Updated notes for Table Power-Up Glitches on Pins Added links to the Technical Reference Manual and Peripheral Pin Configurations in Chapter 4 Functional Description Added a note about ADC2 error in Section 4.2.2.1 SAR ADC Updated Section 4.1.3.8 Watchdog Timers Added Table ADC Calibration Results Updated Section 5.6.2 Current Consumption in Other Modes Updated RF transmit power in Section 6.2 Bluetooth 5 (LE) Radio Updated the typo in Section 7 Packaging Updated Chapter Related Documentation and Resources
2022-04-13	v1.2	<ul style="list-style-type: none"> Added a new chip variant ESP32-C3FH4AZ; Updated Figure ESP32-C3 Functional Block Diagram; Added the wake up source for Deep-sleep mode in Section 4.1.3.6 Power Management Unit.
2021-10-26	v1.1	<ul style="list-style-type: none"> Updated Figure ESP32-C3 Functional Block Diagram to show power modes; Added CoreMark score in Features; Updated Table Pin Description to show default pin functions; Updated Figure ESP32-C3 Power Scheme and related descriptions; Added Table SPI Signals; Added note 3 to Table Recommended Operating Conditions; Other updates to wording.
2021-05-28	v1.0	<ul style="list-style-type: none"> Updated power modes; Updated Section 3 Boot Configurations; Updated some clock names and their frequencies in Section 4.1.3.3 Clock; Added clarification about ADC1 and ADC2 in Section 4.2.2.1 SAR ADC; Updated the default configuration of UORXD and UOTXD after reset in Table IO MUX; Updated sampling rate in Table ADC Characteristics; Updated Table Reliability Qualifications; Added the link to recommended PCB land pattern in Chapter 7 Packaging.

Cont'd on next page

Cont'd from previous page

Date	Version	Release notes
2021-04-23	v0.8	Updated <i>Wi-Fi Radio</i> and <i>Bluetooth 5 (LE) Radio</i> data.
2021-04-07	v0.7	<ul style="list-style-type: none"> • Updated information about USB Serial/JTAG Controller; • Added GPIO2 to Section 3 <i>Boot Configurations</i>; • Updated Figure <i>Address Mapping Structure</i>; • Added Table IO MUX and Table <i>Power-Up Glitches on Pins</i> in Section 4.1.3.1 <i>IO MUX and GPIO Matrix</i>; • Updated information about SPI2 in Section 4.2.1.2 <i>SPI Controller</i>; • Updated fixed-priority channel scheme in Section 4.1.1.2 <i>GDMA Controller</i>; • Updated Table <i>Reliability Qualifications</i>.
2021-01-18	v0.6	<ul style="list-style-type: none"> • Clarified that of the 400 KB SRAM, 16 KB is configured as cache; • Updated maximum value to standard limit value in Table <i>TX EVM Test</i> in Section 6.1.1 <i>Wi-Fi RF Transmitter (TX) Characteristics</i>.
2021-01-13	v0.5	<ul style="list-style-type: none"> • Updated information about Wi-Fi; • Added connection between in-package flash ports and chip pins to table notes in Section Pin Definitions; • Updated Figure <i>ESP32-C3 Power Scheme</i>, added Figure <i>Visualization of Timing Parameters for Power-up and Reset</i> and Table <i>Description of Timing Parameters for Power-up and Reset</i> in Section 2.5.2 <i>Power Scheme</i>; • Added Figure <i>Visualization of Timing Parameters for the Strapping Pins</i> and Table <i>Description of Timing Parameters for the Strapping Pins</i> in Section 3 <i>Boot Configurations</i>; • Updated Table Peripheral Pin Configurations; • Added Chapter 5 <i>Electrical Characteristics</i>; • Added Chapter 7 <i>Packaging</i>.
2020-11-27	v0.4	Preliminary version.



Disclaimer and Copyright Notice

Information in this document, including URL references, is subject to change without notice.

ALL THIRD PARTY'S INFORMATION IN THIS DOCUMENT IS PROVIDED AS IS WITH NO WARRANTIES TO ITS AUTHENTICITY AND ACCURACY.

NO WARRANTY IS PROVIDED TO THIS DOCUMENT FOR ITS MERCHANTABILITY, NON-INFRINGEMENT, FITNESS FOR ANY PARTICULAR PURPOSE, NOR DOES ANY WARRANTY OTHERWISE ARISING OUT OF ANY PROPOSAL, SPECIFICATION OR SAMPLE.

All liability, including liability for infringement of any proprietary rights, relating to use of information in this document is disclaimed. No licenses express or implied, by estoppel or otherwise, to any intellectual property rights are granted herein.

The Wi-Fi Alliance Member logo is a trademark of the Wi-Fi Alliance. The Bluetooth logo is a registered trademark of Bluetooth SIG.



All trade names, trademarks and registered trademarks mentioned in this document are property of their respective owners, and are hereby acknowledged.

Copyright © 2026 Espressif Systems (Shanghai) Co., Ltd. All rights reserved.





www.espressif.com

Looking for pricing, stock, or lifecycle information?

Click below to explore more details on WIN SOURCE:

-  [View ESP32-C3FH4X on WIN SOURCE](#)
-  [Espressif Information](#)

Optimize Your Supply Chain with WIN SOURCE Solutions

-  Global Sourcing Solution
-  Obsolete Management
-  Cost Control Management
-  Shortage Management
-  Alternative Solution
-  Excess Inventory Management