



**THE DATASHEET OF
ZXLD1371QEV2**



ZXLD1371QE2 EVALUATION BOARD USER GUIDE

DESCRIPTION

The ZXLD1371QE2, Figure 1, is an evaluation board for the ZXLD1371QE2 LED driver chip. The board is in a Buck-Boost configuration with an input voltage range of 5.4-30 VDC and will drive a string of up to 5 LEDs. It is set for an output current of 680mA and offers convenient connections for external control inputs and monitoring. The board also includes filter components for conducted EMC.

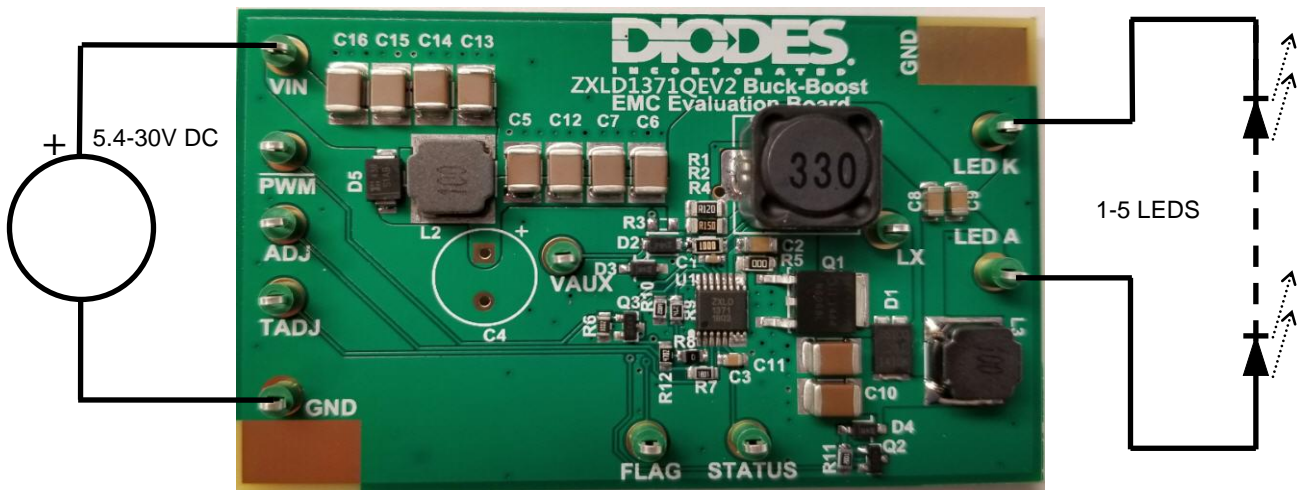

Figure 1: ZXLD1371QE2 evaluation board and connection diagram

QUICK START

- 1) Connect 12V DC supply across Vin and GND points (observe correct polarity).
- 2) Connect LED string across LED A and LED K points (observe correct polarity). LED current is set at 680mA, so ensure LED string is capable of this current.
- 3) Cover LED string or wear eye protection. Do not look directly at LEDs in use.
- 4) Switch on DC power supply.

ZXLD1371QE2 Connection Point Definition	
Name	Description
Vin	Positive supply voltage. 5.4 to 30V
GND	Supply Ground (0V).
PWM	External PWM dimming input (note that this input is inverted)
ADJ	External DC dimming input (Remove R8 for DC Dimming)
TADJ	External thermal dimming input (NTC to GND)
VAUX	VAUX monitoring point
FLAG	FLAG pin monitoring point
STATUS	STATUS pin monitoring point
LX	LX monitoring point
LED K	LED Cathode connection
LED A	LED Anode connection

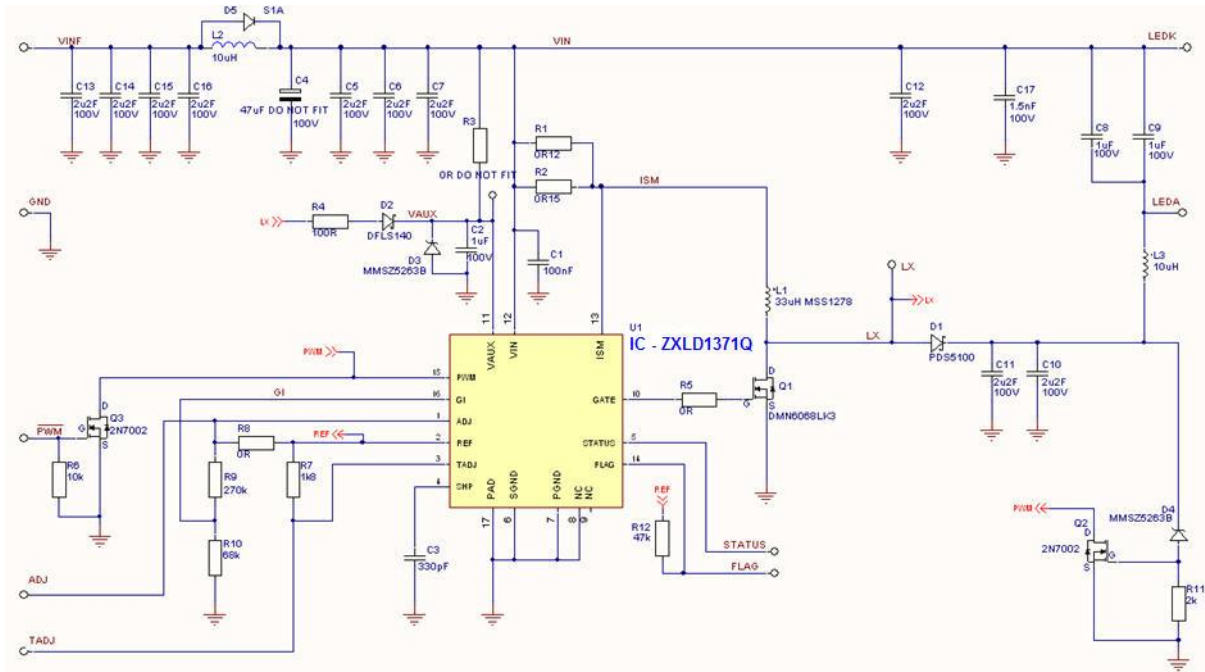

Figure 2: ZXLD1371QEV2 evaluation board Schematic

ZXLD1371QEV2 EVALUATION BOARD REFERENCE DESIGN

The ZXLD1371QEV2 is a Buck-Boost reference design, based around the ZXLD1371 lighting IC. The circuit will accept an input voltage from 5.4 to 30 VDC and can drive an output string of up to 5 LEDs at 680mA. The board has three control inputs and multiple signal monitoring points.

The PWM input allows the user to input a PWM brightness signal. It is recommended to be between 100Hz and 500Hz for maximum LED current dynamic range. Note that the PCB includes a circuit that inverts the signal fed onto this input, in order that the input can be wire-ORed with the over-voltage protection circuit.

The ADJ input allows for DC dimming input, with a voltage between 0.125V and 1.25V for full brightness. In order to use an external control on ADJ, R8 must be removed.

The TADJ input is for connection of an external 10k NTC thermistor which will dim the LEDs as temperature increases, for maximizing LED lifetime. With a 10k NTC and R7 = 1.8kΩ, the thermal trip point will be around 70°C.

The VAUX monitoring point allows easy connection to the chip auxiliary power supply and measurement of the bootstrap circuit where used. It can also be used to feed in an external source of VAUX if R3 and R4 are removed. R4 connects VAUX to LX through D2 as a bootstrap circuit, allowing for operation at low Vin values (5-8V). If bootstrapping is not required, remove R4 and fit R3 = 0Ω.

FLAG and STATUS monitoring points allow these outputs of the chip to be monitored. For further information on output information on these pins see the ZXLD1371 datasheet.

The LX switching point can be monitored on the test point, in order to easily monitor the output PWM.

The LED string load can be connected across the LED A and LED K points.

In Buck-Boost configuration the switching voltage at LX is the sum of the input and load voltages, which can therefore approach 50V when driving up to 5 LEDs.

ZXLD1371QEV2 Component list

QTY	PCB IDENT	VALUE	DESCRIPTION
1	U1	ZXLD1371Q	TSSOP16EP LED driver IC – Diodes Inc.
1	Q1	DMN6068LK3	60V N-Channel Enhancement Mode MOSFET – Diodes Inc.
2	Q2, Q3	2N7002	SOT23 FET - Diodes
1	D1	PDS5100	Freewheeling diode 5A, 100V – Diodes Inc.
1	D2	DFLS140	Schottky diode 1A, 40V – Diodes Inc.
2	D3, D4	MMSZ5263B	Zener, 51V 400mW SOD123 – Diodes Inc.
1	D5	S1A	Diode, 1A SMA – Diodes Inc
1	R1	0R15	Resistor 1206 1% thick film 250ppm generic
1	R2	0R12	Resistor 1206 1% thick film 250ppm generic
0	R3	DO NOT FIT	Resistor 0805
1	R4	100R	Resistor 1206 1% thick film 250ppm generic
1	R5	0R0	Resistor 1206 1% thick film 250ppm generic
1	R6	10k	Resistor 0805 1% thick film 250ppm generic
1	R7	1k8	Resistor 0805 1% thick film 250ppm generic
1	R8	0R	Resistor 0805 1% thick film 250ppm generic
1	R9	270k	Resistor 0805 1% thick film 250ppm generic
1	R10	68k	Resistor 0805 1% thick film 250ppm generic
1	R11	2k	Resistor 0805 1% thick film 250ppm generic
1	R12	47k	Resistor 0805 1% thick film 250ppm generic
1	C1	100nF	Capacitor 0603, 100V X7R generic
3	C2, C8, C9	1uF	Capacitor 1206, 100V X7R generic
1	C3	330pF	Capacitor 0805, 100v C0G generic
0	C4	DO NOT FIT	Electrolytic capacitor P5D10
10	C5, C6, C7, C10, C11, C12, C13, C14, C15, C16	2u2F	Capacitor, 1812, 100V X7R generic Murata GRM43ER72A225KA01L
1	C17 (no ident)	1n5	Capacitor 0805, 100v C0G generic
1	L1	33uH	Coilcraft MSS1278-333MLB NIC Components NPIS27H330MTRF
2	L2, L3	10uH	Murata LQH88PN100M38L
11	TP1, TP2, TP3, TP4, TP5, TP6, TP7, TP8, TP9, TP10, TP11	Test Point	2.15mm dia. test loops, green, generic, Hughes 100-108

Note: The component values and part numbers are correct at the time of publication. Diodes Inc. reserves the right to substitute other parts where necessary, without further notification.

IMPORTANT NOTICE

DIODES INCORPORATED MAKES NO WARRANTY OF ANY KIND, EXPRESS OR IMPLIED, WITH REGARD TO THIS DOCUMENT, INCLUDING, BUT NOT LIMITED TO, THE IMPLIED WARRANTIES OF MERCHANTABILITY AND FITNESS FOR A PARTICULAR PURPOSE (AND THEIR EQUIVALENTS UNDER THE LAWS OF ANY JURISDICTION).

Diodes Incorporated and its subsidiaries reserve the right to make modifications, enhancements, improvements, corrections or other changes without further notice to this document and any product described herein. Diodes Incorporated does not assume any liability arising out of the application or use of this document or any product described herein; neither does Diodes Incorporated convey any license under its patent or trademark rights, nor the rights of others. Any Customer or user of this document or products described herein in such applications shall assume all risks of such use and will agree to hold Diodes Incorporated and all the companies whose products are represented on Diodes Incorporated website, harmless against all damages.

Diodes Incorporated does not warrant or accept any liability whatsoever in respect of any products purchased through unauthorized sales channels. Should Customers purchase or use Diodes Incorporated products for any unintended or unauthorized application, Customers shall indemnify and hold Diodes Incorporated and its representatives harmless against all claims, damages, expenses, and attorney fees arising out of, directly or indirectly, any claim of personal injury or death associated with such unintended or unauthorized application.

Products described herein may be covered by one or more United States, international or foreign patents pending. Product names and markings noted herein may also be covered by one or more United States, international or foreign trademarks.

LIFE SUPPORT

Diodes Incorporated products are specifically not authorized for use as critical components in life support devices or systems without the express written approval of the Chief Executive Officer of Diodes Incorporated. As used herein:

- A. Life support devices or systems are devices or systems which:
1. are intended to implant into the body, or
 2. support or sustain life and whose failure to perform when properly used in accordance with instructions for use provided in the labeling can be reasonably expected to result in significant injury to the user.
- B. A critical component is any component in a life support device or system whose failure to perform can be reasonably be expected to cause the failure of the life support device or to affect its safety or effectiveness.

Customers represent that they have all necessary expertise in the safety and regulatory ramifications of their life support devices or systems, and acknowledge and agree that they are solely responsible for all legal, regulatory and safety-related requirements concerning their products and any use of Diodes Incorporated products in such safety-critical, life support devices or systems, notwithstanding any devices- or systems-related information or support that may be provided by Diodes Incorporated. Further, Customers must fully indemnify Diodes Incorporated and its representatives against any damages arising out of the use of Diodes Incorporated products in such safety-critical, life support devices or systems.

Copyright © 2018, Diodes Incorporated

www.diodes.com

Looking for pricing, stock, or lifecycle information?

Click below to explore more details on WIN SOURCE:

 [View ZXLD1371QEV2 on WIN SOURCE](#)

 [Diodes Incorporated](#) Information

Optimize Your Supply Chain with WIN SOURCE Solutions

-  Global Sourcing Solution
-  Obsolete Management
-  Cost Control Management
-  Shortage Management
-  Alternative Solution
-  Excess Inventory Management