



**THE DATASHEET OF
LP0002/01-LI98-0.25**



Evaluates: MAX20444B/ MAX20444C

MAX20444B Evaluation Kit

General Description

The MAX20444B evaluation kit (EV kit) demonstrates the MAX20444B integrated, 4-channel, high-brightness LED driver with boost controller and I²C interface for automotive displays.

The EV kit operates from a DC supply voltage between 4.5V and 36V, and the switching frequency can be set at either 2.2MHz or 400kHz. The EV kit can be configured to operate in stand-alone mode or in I²C mode. Spread-spectrum mode (SSM) for EMI improvement is enabled by default, but it can be disabled through a register bit. The EV kit demonstrates phase-shifted pulse-width modulation (PWM) dimming, which can be performed either externally using a PWM signal applied to the DIM PCB pad or internally by programming the desired dimming frequency and individual duty cycle using I²C. The hybrid dimming feature can also be enabled through a register bit to reduce EMI. The EV kit also demonstrates fault protection for short LED, open LED, boost output undervoltage and overvoltage, and overtemperature.

For operation at switching frequencies other than 2.2MHz or 400kHz, the external components should be chosen according to the calculations in the MAX20444B IC data sheet.

The EV kit provides an I²C interface that can operate in conjunction with the MINIQUEB+ adapter board or a third-party I²C master. The EV kit also includes Windows®-compatible software that provides a simple graphical user interface (GUI) for exercising the features of the IC.

Note: The MAX20444B EV kit is identical to the MAX20444 EV kit, with the exception of the U1 component. The photos and figures indicate MAX20444, but there are no differences between this version and the standard version.

Benefits and Features

- Demonstrates Robustness of MAX20444B
- Wide 4.5V to 36V Input Operating Range (Up to 52V Load Dump)
- Powers HB LEDs (Up to four strings) for Medium-to-Large-Sized LCD Displays in Automotive and Display Backlight Applications
- 400kHz to 2.2MHz Resistor-Programmable Switching Frequency with Spread-Spectrum Option
- Phase-Shift Dimming Option
- Demonstrates Cycle-by-Cycle Current Limit and Thermal-Shutdown Features
- Demonstrates Wide Dimming Ratio
- Demonstrates Failsafe Operation
- I²C Programmability
- Dedicated GUI
- Proven PCB and Thermal Design
- Fully Assembled and Tested

EV Kit Contents

FILE	DESCRIPTION
MAX20444BGUISetupV01.exe	Windows GUI Installer

[Ordering Information](#) appears at end of data sheet.

Windows is a registered trademark and registered service mark of Microsoft Corporation.

319-100309; Rev 1; 9/21

Quick Start

Required Equipment

- MAX20444B EV kit
- 5V to 36V, 4A DC power supply
- Two digital voltmeters (DVMs)
- Four series-connected HB LED strings (6 LEDs each) rated to no less than 120mA
- Current probe to measure the HB LED current
- MINIQUSB+ interface board with USB cable
- Windows-compatible PC with a spare USB port

Note: In the following sections, software-related items are identified by bolding. Text in **bold** refers to items directly from the EV kit software. Text in **bold and underlined** refers to items from the Windows operating system.

Procedure

The EV kit is fully assembled and tested. Perform the following steps to verify board operation. **Caution:** Do not turn on the power supply until all connections are completed.

Stand-Alone Mode

- 1) Verify that jumper J17 is closed and that jumper J22 is open (2.2MHz switching frequency selected).
- 2) Verify that jumper J1 is closed (DS1 green LED connected).
- 3) Verify that jumper J20 is closed (FAULT signaling enabled).
- 4) Verify that a shunt is installed across pins 1-2 on jumper J2 (device enabled).
- 5) Verify that a shunt is installed across pins 1-2 on jumper JMP1 (hybrid dimming disabled).
- 6) Verify that a shunt is installed across pins 1-3 on jumper JMP8 (LED short detection enabled).
- 7) Verify that jumpers JMP3, JMP6-JMP7, and JMP9 have shunts installed across pins 1-2 (bleed resistors connected, all current sinks enabled).
- 8) Verify that a shunt is installed across pins 1-2 on jumper JMP2 (Phase shifting enabled).
- 9) Verify that a shunt is installed across pins 1-2 on jumper JMP4 (LED current range set to 85-120mA).
- 10) Verify that jumper J8 is closed (LED current set to 100mA).
- 11) Connect the positive terminal of the power supply to the IN PCB pad. Connect the negative terminal of the power supply to a PGND PCB pad.
- 12) Connect a DVM across the OUT1 and GND PCB pads.
- 13) Connect the four LED strings from VOUT to the OUT1, OUT2, OUT3 and OUT4 PCB pads.
- 14) Clip the current probe across the channel 1 HB LED+ wire to measure the LED current.
- 15) Turn on the power supply and set it to 12V. The green LED (DS1) and the LED strings should be on at this point.
- 16) Measure the voltage from each of the OUT_ PCB pads to PGND and verify the lowest voltage is approximately 1V.
- 17) Measure the LED current using the current probe and verify all channels.

I²C Mode

- 1) Visit www.maximintegrated/evkitsoftware to download the latest version of the EV kit software, MAX20444BGUISetupV01.exe.
- 2) Install the EV kit software (GUI) on your PC by running the MAX20444BGUISetupV01.exe program. The EV kit software application will be installed together with the required MINIQUSB+ drivers.
- 3) Verify that jumper J17 is closed and that jumper J22 is open (2.2MHz switching frequency selected).
- 4) Verify that jumper J1 is closed (DS1 green LED connected).
- 5) Verify that jumper J23 is closed (FSEN function disabled).
- 6) Verify that jumper J20 is closed (FAULT signaling enabled).
- 7) Verify that a shunt is installed across pins 1-2 on jumper J2 (device enabled).
- 8) Verify that jumpers JMP1 and JMP8 have shunts installed across pins 1-4.
- 9) Verify that jumpers JMP3, JMP6-JMP7, and JMP9 have shunts installed across pins 1-2 (bleed resistors connected, all current sinks enabled).
- 10) Verify that jumpers JMP2 and JMP4 have shunts installed across pins 1-3 (SDA and SCL PCB pads connected to SDA/PSEN and SCL/IRANGE IC's pins).
- 11) Connect the MINIQUSB+ interface board's P3 header to the J24 header on the EV kit.
- 12) Connect the positive terminal of the power supply to the IN PCB pad. Connect the negative terminal of the power supply to a PGND PCB pad.

MAX20444B Evaluation Kit

Evaluates: MAX20444B/
MAX20444C

- 13) Connect a DVM across the OUT1 and GND PCB pads.
- 14) Connect the four LED strings from VOUT to the OUT1, OUT2, OUT3, and OUT4 PCB pads.
- 15) Clip the current probe across the channel 1 HB LED+ wire to measure the LED current.
- 16) Turn on the power supply and set it to 12V. The green LED (DS1) should be on at this point.
- 17) Launch the EV kit software application.
- 18) From the EV kit software toolbar, select **Device** → **Scan for Address**. The GUI scans the I2C bus for available slave addresses on the bus and selects the first one (in this case, the MAX20444B I2C address). Press **OK** once the MAX20444B I2C address has been found.
- 19) Verify that the status bar in the bottom-right corner of the GUI displays EV Kit: Connected, as shown in [Figure 1](#).
- 20) In the **0x02 ISET** register group box, select the desired OUT_ current value (45mA to 120mA in 5mA steps) by acting on the **ISET** slider bar, then click the **Refresh** button.
- 21) In the **0x02 ISET** register group box, check ENA to activate the driver.
- 22) Measure the voltage from each of the OUT_ PCB pads to PGND and verify that the lowest voltage is approximately 1V.
- 23) Measure the LED current using the current probe and verify all channels.
- 24) For more details on how to use the GUI and all of the features available, click on the GUI Help menu item.

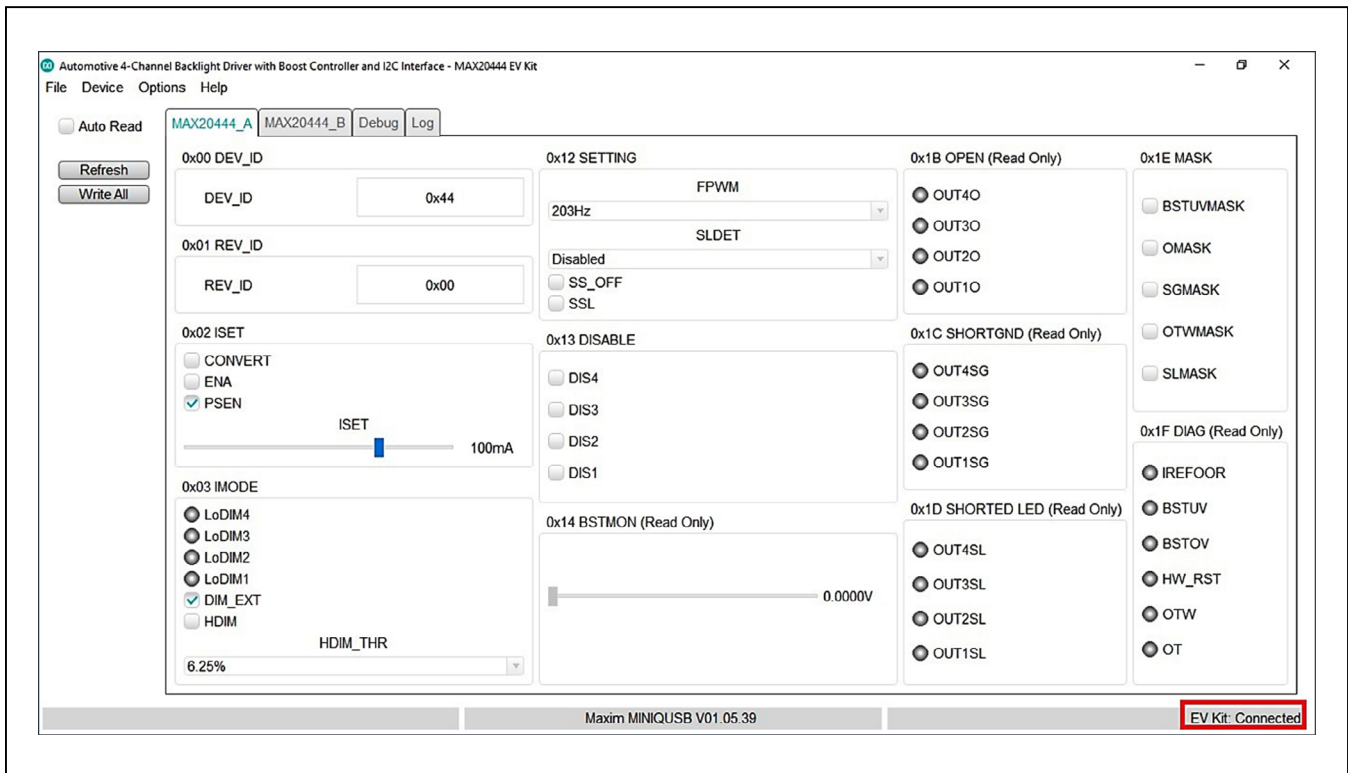

Figure 1. MAX20444B Evaluation Kit Software (GUI)

Detailed Description of Hardware

The MAX20444B EV kit demonstrates the MAX20444B HB LED driver with an integrated step-up DC-DC pre-regulator followed by six linear current sinks to drive up to six strings of LEDs. The pre-regulator switches at 2.2MHz (or at 400kHz) and operates as a current-mode-controlled regulator, providing up to 480mA for the linear current sinks, as well as overvoltage protection. The cycle-by-cycle current limit is set by resistor R27, while resistors R4 and R5 set the overvoltage protection voltage to 29V. The pre-regulator power section consists of inductor L2, power-sense resistor R27, Q4 MOSFET, and switching diode D1. The EV kit circuit operates from a 4.5V DC supply voltage up to the HB LED forward-string voltage. The circuit handles load-dump conditions up to 50V.

The EV kit circuit demonstrates ultra-low shutdown current when the EN pin of the device is pulled to ground by shorting the EN PCB pad to ground. Each of the four linear current sinks (OUT1–OUT4) is capable of operating up to 48V, sinking up to 120mA per channel.

Each of the four channels' linear current sinks is I²C-configurable for 45mA to 120mA in 5mA steps, or can be disabled independently by acting on the **0x13 DISABLE** register group box.

If the device is used in stand-alone mode, the four channels' linear current sinks are configured by selecting the current range through the SCL/IRANGE pin (SCL/IRANGE set to GND → Lower: 45mA-80mA / SCL/IRANGE set to VCC → Higher: 85-120mA) and by setting the LED strings' current in steps of 5mA through a resistor connected between ISET pin and GND.

In both modes, jumpers JMP3, JMP6-JMP7 and JMP9 can be used to disable outputs selectively when the HB LED string is not connected.

The EV kit features PCB pads to facilitate connecting HB LED strings for evaluation. The VOUT PCB pads are used to connect each HB LED string's anode to the DC-DC pre-regulator output. The OUT1–OUT4 PCB pads are used to connect each HB LED string's cathode to the respective current sink. Capacitors C18, C23, C24 and C25 are included in the design to prevent oscillations and to provide stability when using long, untwisted HB LED connecting cables during lab evaluation. These capacitors are not required if the connection between the LED driver and the HB LEDs is a low-inductance connection.

A DIM PCB pad is provided for using a digital PWM signal to control the brightness of the HB LEDs. Test points are also provided for easy access to the device's VCC regulator output as well as the COMP pin and the switching node of the pre-regulator (LX).

SDA and SCL voltages (JMP2-JMP4, J18-J19, J21)

SDA and SCL voltage supplies can be selected between the VCC voltage and the fixed 3.3V provided by the MINIQUSB+. Alternatively, the user can force an external voltage as digital reference. See [Table 1](#) for jumper settings.

Power LED Enable (J1)

A green LED (DS1) is used to indicate that the EV kit is powered on. The LED can be disconnected from the power supply, allowing precise current-consumption evaluation. See [Table 2](#) for shunt positions.

Enable (EN)

The EV kit features an enable input that can be used to enable/disable the device and place it in shutdown mode. To enable the EV kit whenever power is applied to IN, place the jumper across pins 1-2 on jumper J2. To enable the EV kit using an external enable signal, place the jumper across pins 2-3 on J2 and apply a logic signal on the EN PCB input pad on the EV kit. A 1MΩ pulldown resistor on the EV kit pulls the EN input to ground in the event that J2 is left open or the EN signal is high impedance. Refer to the *Enable* section in the MAX20444B IC data sheet for additional information. See [Table 3](#) for J2 jumper settings.

Table 1. SDA and SCL supply (JMP2-JMP4, J18-J19, J21)

SHUNT POSITION					SDA AND SCL SUPPLY
JMP2	JMP4	J18	J19	J21	
1-3*	1-3*	Open*	Open*	Open*	3.3V (with MINIQUSB+ connected)
1-3	1-3	Closed	Closed	Open	VCC
1-3	1-3	Open	Open	1-2	Externally provided

*Default position.

Table 2. DS1 Enable (J1)

SHUNT POSITION	DS1 POWER LED
Closed*	Connected
Open	Disconnected

*Default position.

Switching Frequency

Jumpers J17 and J22 are used to set the switching frequency of the MAX20444B to either 2.2MHz or 400kHz. When J17 is closed and J22 is open, the switching frequency is set to 2.2MHz. When J17 is open and J22 is closed, the switching frequency is nominally 400kHz. See [Table 4](#) for jumper settings.

The EV kit is optimized for 2.2MHz switching operation by default. When selecting a switching frequency of 400kHz, L2 should be changed to 22µH to maintain acceptable efficiency. Other component value adjustments may be needed. Refer to the *Oscillator Frequency* section in the MAX20444B IC data sheet for more information.

Table 3. Enable (J2)

SHUNT POSITION	EN PIN	EVKIT OPERATION
1-2*	Connected to IN	Enabled when IN is powered.
2-3	Connected to EN PCB pad	Enabled/disabled by signal on EN PCB pad.

*Default position.

HB LED Current

Current for the device’s current sinks (on all four channels) is fully configurable using I²C (**ISET** slider bar in the **0x02 ISET** register group box).

When operated in stand-alone mode, the EV kit features jumpers JMP4, J3-J6, J8, J10, J12 and J14 to configure the device’s current sinks on all four channels. See [Table 5](#) for proper jumper settings to configure the current-sink limits.

Note: When setting the LED current in stand-alone mode, the jumper J23 must be kept open.

Table 4. Switching Frequency (J17 and J22)

SHUNT POSITION		RT PIN	EVKIT OPERATION
J17	J22		
Closed*	Open*	RT connected to GND via 13.3kΩ resistor	2.2MHz switching frequency
Open	Closed	RT connected to GND via 76.8kΩ resistor	400kHz switching frequency

*Default position.

Table 5. LED Current (JMP4, J3-J6, J8, J10, J12 and J14)

SCL/IRANGE	ISET RESISTOR VALUE	JUMPER	SHUNT POSITION	OUT_CURRENT (mA)
JMP4 shunted in 1-4 position → 45-80mA current range	3.48k	J14	Closed	45
	7.15k	J12	Closed	50
	12k	J10	Closed	55
	18.7k	J8	Closed	60
	27.4k	J6	Closed	65
	39k	J5	Closed	70
	59k	J4	Closed	75
	84.5k	J3	Closed	80
JMP4 shunted in 1-2 position* → 85-120mA current range	3.48k	J14	Closed	85
	7.15k	J12	Closed	90
	12k	J10	Closed	95
	18.7k*	J8	Closed	100
	27.4k	J6	Closed	105
	39k	J5	Closed	110
	59k	J4	Closed	115
	84.5k	J3	Closed	120

*Default position.

**Channel 1–Channel 4
Current-Sink Disabling**

The EV kit features jumpers JMP3, JMP6–JMP7, and JMP9, which are used to put each OUT_ current sink in one of three operating states:

- 1) Normal operation (i.e., OUT_ is connected to the corresponding ring on the board edge and LEDs are connected from that location to the pre-regulator output VOUT);
- 2) OUT_ connected through a 12kΩ resistor to GND, and thus disabled;
- 3) OUT_ shorted to GND (used to test fault detection).

To disable a channel, install a jumper in the channel's respective jumper across pins 1-3, connecting the OUT_ to ground through a 12kΩ resistor. The dimming algorithm in the IC requires that higher numbered OUT_ current sinks be disabled first. For example, if only two strings are needed, OUT1–OUT2 should be used, with OUT3 and OUT4 disabled. See [Table 6](#) for jumper settings. The 100kΩ bleed resistors are installed to prevent the OUT_ leakage current from dimly illuminating large LED strings when the DIM signal is low. Note that each channel can be alternatively disabled (I2C mode only) by acting on the **0x13 DISABLE** register group box.

HB LED Digital Dimming Control

The EV kit features a DIM PCB input pad for connecting an external digital PWM signal. Apply a digital PWM signal with a 0.8V logic-low level (or less) and 2.1V logic-high level (or greater). The DIM signal frequency should be at least 100Hz. If the DIM frequency is changed during operation, the MAX20444B must be powered off and on again to register the change. To adjust the HB LED brightness, vary the signal duty cycle from 0% to 100% and maintain a minimum pulse width of 500ns. Apply the digital PWM signal to the DIM PCB pad. The DIM input of the IC is pulled up internally with a 5μA (typ) current source.

Dimming can also be performed by programming the desired dimming level using I2C. External dimming is enabled by default at each device's power-up. To disable it, first uncheck **DIM_EXT** in the **0x03 IMODE** register group box, then select one of the available dimming frequencies in the **FPWM** section contained in the **0x12 SETTING** register group box. Individual channel brightness levels can finally be selected by acting on the TON1–TON4 slider bars.

Note: to ensure that correct brightness levels are selected in internal dimming mode, each TON_ slider bar must be zeroed at each device's power-up.

For additional information on the device's digital dimming feature, refer to the *Dimming* section in the MAX20444B IC data sheet.

Table 6. Selecting OUT_ Channels Operating State (JMP3, JMP6–JMP7 and JMP9)

OUT_	JUMPER	SHUNT POSITION	CHANNEL OPERATION
OUT1	JMP9	1-2*	Channel 1 operational; connect an HB LED string** between VOUT and OUT1. Bleed resistor connected.
		1-3	Channel 1 not used. OUT1 current sink disabled.
		1-4	Channel 1 shorted to GND to simulate a fault.
OUT2	JMP7	1-2*	Channel 2 operational; connect an HB LED string** between VOUT and OUT2. Bleed resistor connected.
		1-3	Channel 2 not used. OUT2 current sink disabled.
		1-4	Channel 2 shorted to GND to simulate a fault.
OUT3	JMP6	1-2*	Channel 3 operational; connect an HB LED string** between VOUT and OUT3. Bleed resistor connected.
		1-3	Channel 3 not used. OUT3 current sink disabled.
		1-4	Channel 3 shorted to GND to simulate a fault.
OUT4	JMP3	1-2*	Channel 4 operational; connect an HB LED string** between VOUT and OUT4. Bleed resistor connected.
		1-3	Channel 4 not used. OUT4 current sink disabled.
		1-4	Channel 4 shorted to GND to simulate a fault.

*Default position.

**The series-connected HB LED string must be rated to no less than 120mA.

Hybrid Dimming Operation

The hybrid dimming feature can be used with both external and internal dimming. The device will determine whether the LED is to be dimmed by reducing the LED current or by chopping the LED current (depending on the hybrid dimming threshold).

In I²C mode, the hybrid dimming threshold is set through the HDIM_THR section contained in the **0x03 IMODE** register group box. To enable the hybrid dimming feature, check **HDIM** in the **0x03 IMODE** register group box.

Hybrid dimming can be enabled in stand-alone mode by connecting a resistor from I.C./HDSET to GND through jumpers J7, J9, J11, and J13. Each resistor value determines the threshold at which analog dimming transitions to PWM dimming. See [Table 7](#) for jumper settings.

For additional information on the device’s dimming feature, refer to the *Hybrid Dimming* section in the MAX20444B IC data sheet.

Phase-Shift Operation

The EV kit demonstrates the phase-shifting feature of the IC. In I²C mode, phase-shift is enabled by default at each device’s power-up. To disable it, uncheck **PSEN** in the **0x02 ISET** register group box. This operation must always be performed before enabling any LED string.

When phase shifting is enabled, each current sink’s turn-on is separated by 360°/n, where n is the number of enabled strings. When phase shifting is disabled, the dimming of each string is controlled directly by the DIM input (or by the FPWM and TON_ settings if internal dimming is enabled), and all current sinks turn on and off at the same time.

Phase-shift enabling/disabling can be performed by acting on JMP2 in stand-alone mode. See [Table 8](#) for jumper settings.

Table 7. Hybrid dimming threshold setting (JMP1, J7, J9, J11 and J13)

I.C./HDSET	I.C./HDSET RESISTOR VALUE	JUMPER	SHUNT POSITION	HYBRID DIMMING THRESHOLD (%)
JMP1 shunted in 1-2 position → I.C./HDSET connected to VCC	3.48k	J13	Open	Hybrid dimming disabled
	12k	J11	Open	
	27.4k	J9	Open	
	59k*	J7	Open	
JMP1 shunted in 1-4 position → I.C./HDSET connected to GND*	3.48k	J13	Open	Hybrid dimming threshold set using I ² C
	12k	J11	Open	
	27.4k	J9	Open	
	59k*	J7	Open	
JMP1 shunted in 1-3 position	3.48k	J13	Closed	6.25
	12k	J11	Closed	12.5
	27.4k	J9	Closed	25
	59k*	J7	Closed	50

*Default position.

Table 8. Phase shifting operation (JMP2)

SHUNT POSITION	SDA/PSEN PIN	EVKIT OPERATION
1-2*	Connected to VCC	Phase shifting enabled
1-4	Connected to GND	Phase shifting disabled

*Default position.

Failsafe Operation (I²C mode only)

The EV kit demonstrates the failsafe feature of the IC. After shunting jumper JMP8 in 1-4 position (I2CDIS/RSDT pin connected to ground), one of the jumpers J3-J6, J8, J10, J12, J14 can be closed before powering up the device to select, through a resistor to ground, the current level to which the current sinks will be enabled in case the FSEN PCB pad is tied to VCC. If jumper J23 is closed, the FSEN/ISET pin is shorted to ground and its function is disabled. Only one jumper at a time may be closed. See [Table 9](#) for jumper settings.

For additional information on the device’s failsafe operation, refer to the *FSEN/ISET pin function* section in the MAX20444B IC data sheet.

Fault-Indicator Output (FLTB)

The EV kit features the device’s open-drain FLTB output. The FLT signal on the PCB pad is pulled up to VCC by resistor R48. FLT goes low when an open-LED or shorted-LED string is detected, during thermal warning/shutdown or during boost undervoltage/overvoltage events. Keep jumper J20 closed to allow DS2 red-LED enabling in case FLT goes low. Refer to the *Fault Protection* section in the MAX20444B IC data sheet for additional information on the FLT signal.

Shorted-LED Detection and Protection

The short-LED threshold is set using I²C in the **SLDET** section contained in the **0x12 SETTING** register group box. A shorted LED is detected when the following condition is satisfied: VOUT > VSLDET.

Table 9. Selecting FSEN resistor (J3-J6, J8, J10, J12, J14, J23)

FSEN RESISTOR VALUE	JUMPER	SHUNT POSITION	OUT_CURRENT (mA)
0 (FSEN shorted to GND)*	J23	Closed	Failsafe disabled
3.48k	J14	Closed	25
7.15k	J12	Closed	25
12k	J10	Closed	50
18.7k	J8	Closed	50
27.4k	J6	Closed	75
39k	J5	Closed	75
59k	J4	Closed	100
84.5k	J3	Closed	100

*Default position.

In stand-alone mode, the short-LED threshold is programmed through the RSDT input. R40 and R41 form a resistor-divider from VCC to RSDT to SGND. A shorted LED is detected when the following condition is satisfied: VOUT > (4 x VRSDT).

When the short-LED threshold is reached, the affected current sink is disabled to reduce excess power dissipation and the FLT indicator asserts low. The short-LED detection feature is regulated through jumper JMP8. See [Table 10](#) for jumper settings.

Overvoltage Detection and Protection

The resistors (R4 and R5) connected to BSTMON are configured for a VOUT_OVP of 29V. This sets the maximum converter output (VOUT) voltage at 29V. During an open-LED string condition, the converter output ramps up to the output overvoltage threshold. Capacitor C3 can be added to provide noise filtering to the overvoltage signal. To reconfigure the circuit for a different voltage, replace resistor R4 with a different value using the following equation:

$$R4 = [(VOUT_OVP/1.23) - 1] \times R5$$

where R5 is 10kΩ, VOUT_OVP is the overvoltage-protection threshold desired, and R4 is the new resistor value for obtaining the desired overvoltage protection.

MOSFET Q1 is an optional overvoltage-protection resistor-divider disconnect switch for ultra-low shutdown current. Refer to the *Open-LED Management and Overvoltage Protection* section in the MAX20444B IC data sheet for additional information.

Table 10. Short-LED detection (JMP8)

SHUNT POSITION	I2CDIS/RSDT PIN	EVKIT OPERATION
1-4*	Connected to GND	Short-LED detection regulated using I ² C
1-2	Connected to VCC	Short-LED detection disabled
1-3	Connected to R40/R41 resistor-divider	Short-LED detection regulated using resistor-divider

*Default position.

MAX20444B Evaluation Kit

Evaluates: MAX20444B/
MAX20444C

Ordering Information

PART	TYPE
MAX20444BEVKIT#	EVKIT

#Denotes RoHS compliant.

MAX20444B EV Kit Bill of Materials

ITEM	REF_DES	DN/DNP	QTY	MFG PART #	MANUFACTURER	VALUE	DESCRIPTION
1	C2, C6, C16	—	3	UMK107BJ105KA; C1608XSR1H105K080AB; CL10A105KB8NNN; GRM188R61H105KAAL	TAIYO YUDEN;TDK; SAMSUNG;MURATA	1UF	CAPACITOR; SMT (0603); CERAMIC CHIP; 1UF; 50V; TOL = 10%; MODEL = _MK SERIES; TG = -55°C TO +85°C
2	C4	—	1	CGA3E3X7S2A104K080AB	TDK	0.1UF	CAPACITOR; SMT (0603); CERAMIC CHIP; 0.1UF; 100V; TOL=10%; TG = -55°C TO +125°C; TC = X7S
3	C5, C26, C31	—	3	C1210C475KSRAC; GRM32ER71H475KA88; GRM32ER71H475KA88; GCM32ER71H475KA55; CGA6P3X7R1H475K250AB	KEMET;MURATA; MURATA;MURATA;TDK	4.7UF	CAPACITOR; SMT (1210); CERAMIC CHIP; 4.7UF; 50V; TOL =10%; TG = -55°C TO +125°C; TC = X7R
4	C9, C10	—	2	EEE-TG1H470LP	PANASONIC	47UF	CAPACITOR; SMT (CASE_F); ALUMINUM-ELECTROLYTIC; 47UF; 50V; TOL = 20%; MODEL = TG SERIES; TG = -40°C TO +125°C
5	C12, C18, C23-C25	—	5	GRM1885C1H102JA01; C1608CDG1H102J080AA; GCM1885C1H102JA16	MURATA;TDK; MURATA	1000PF	CAPACITOR; SMT (0603); CERAMIC CHIP; 1000PF; 50V; TOL = 5%; TG = -55°C TO +125°C
6	C13	—	1	C0603C473KSRAC; GRM188R71H473KA61; GCM188R71H473KA55; CGA3E2X7R1H473K080AA	KEMET;MURATA; MURATA;TDK	0.047UF	CAPACITOR; SMT (0603); CERAMIC CHIP; 0.047UF; 50V; TOL = 10%; MODEL = X7R; TG = -55°C TO +125°C; TC = X7R
7	C17	—	1	ECJ-1VC1H100D	PANASONIC	10PF	CAPACITOR; SMT (0603); CERAMIC CHIP; 10PF; 50V; TOL = ±5PF; MODEL = COG; TG = 55°C TO +85°C; TC = +/-
8	C20	—	1	GRM188R71A225KE15; CL10B225KP8NNN; C1608X7R1A225K080AC	MURATA;SAMSUNG;TDK	2.2UF	CAPACITOR; SMT (0603); CERAMIC CHIP; 2.2UF; 10V; TOL = 10%; TG = -55°C TO +125°C; TC=X7R
9	C21	—	1	GRM1885C1H222JA01	MURATA	2200PF	CAPACITOR; SMT (0603); CERAMIC; 2200PF; 50V; TOL = 5%; TG = -55°C TO +125°C; TC = COG
10	C22	—	1	C0603C0683J5RAC	KEMET	0.068UF	CAPACITOR; SMT; 0603; CERAMIC; 0.068uF; 50V; 5%; X7R; -55°C to + 125°C; 0 ±15%°C MAX.
11	C27	—	1	06035C101JAT	AVX	100PF	CAPACITOR; SMT (0603); CERAMIC CHIP; 100PF; 50V; TOL = 5%; TG = -55°C TO +125°C; TC = X7R
12	C28	—	1	06035C220JAT	AVX	22PF	CAPACITOR; SMT (0603); CERAMIC CHIP; 22PF; 50V; TOL = 5%; TG = -55°C TO +125°C; TC = X7R
13	C226	—	1	C2012X7R1H225K125AC; CGA4J3X7R1H225K125AB; CGA4J3X7R1H225K125AE	TDK;TDK;TDK	2.2UF	CAPACITOR; SMT (0805); CERAMIC CHIP; 2.2UF; 50V; TOL = 10%; TG = -55°C TO +125°C; TC = X7R
14	COMP_LX, TP1, TP2, VCC	—	5	5011	N/A	5011	TEST POINT; PIN DIA = 0.125IN; TOTAL LENGTH = 0.445IN; BOARD HOLE = 0.063IN; BLACK; PHOSPHOR BRONZE WIRE SILVER PLATE FINISH;
15	D1	—	1	NRVBS260T3G	ON SEMICONDUCTOR	NRVBS260T3G	DIODE; SCH; SURFACE MOUNT SCHOTTKY POWER RECTIFIER; SMB; PIV=60V; IF=2A
16	D2, D3	—	2	BZG03C18	VISHAY SEMICONDUCTORS	18V	DIODE; ZNR; SMT (DO-214AC); VZ = 18V; IZM = 0.025A
17	D4	—	1	B160B-13-F	DIODES INCORPORATED	B160B-13-F	DIODE; SCH; SMB (DO-214AA); PIV = 60V; IF = 1A
18	D5	—	1	CMPD914E	CENTRAL SEMICONDUCTOR	CMPD914E	DIODE; SWT; SMT (SOT23-3); PIV = 150V; IF = 0.1A

MAX20444B Evaluation Kit

Evaluates: MAX20444B/
MAX20444C

MAX20444B EV Kit Bill of Materials (continued)

ITEM	REF_DES	DNI/DNP	QTY	MFG PART #	MANUFACTURER	VALUE	DESCRIPTION
19	DIM, EN, FLT, FSENISET, GND, GND1, GND2, I.C./HDSET, I2C/DI/RSDDT, IN, OUT1-OUT4, PGND, PGND1, PGND2, SCL, SDA, SYNC, VOUT, VOUT1-VOUT3	—	24	9020 BUSS	WEICO WIRE	MAXIMPAD	EVK KIT PARTS; MAXIM PAD; WIRE: NATURAL; SOLID; WEICO WIRE; SOFT DRAWN BUS TYPE-S; 20AWG
20	DS1	—	1	LGL29K-F2J1-24-Z	OSRAM	LGL29K-F2J1-24-Z	DIODE; LED; SMARTLED; GREEN; SMT; PIV = 1.7V; IF = 0.02A
21	DS2	—	1	LS L29K-G1J2-1-Z	OSRAM	LS L29K-G1J2-1-Z	DIODE; LED; SMART; RED; SMT (0603); PIV = 1.8V; IF = 0.02A; -40°C TO +100°C
22	J1, J3-J14, J17-J20, J22, J23	—	19	PBC02SAAN	SULLINS ELECTRONICS CORP.	PBC02SAAN	CONNECTOR; MALE; THROUGH HOLE; BREAKAWAY; STRAIGHT; 2PINS
23	J2, J21	—	2	PEC03SAAN	SULLINS ELECTRONICS CORP.	PEC03SAAN	EVKIT PART-CONNECTOR; MALE; THROUGH HOLE; BREAKAWAY; STRAIGHT; 3PINS; -65°C TO +125°C;
24	J24	—	1	803-87-020-20-001101	PRECI-DIP SA	803-87-020-20-001101	EVKIT PART-CONNECTOR; FEMALE; TH; DOUBLE ROW; 2.54MM; RIGHT ANGLE SOLDER TAIL; MATING PIN DIA 0.76MM; RIGHT ANGLE; 20PINS;
25	J25	—	1	HTSW-112-11-G-S-RA	SAMTEC	HTSW-112-11-G-S-RA	CONNECTOR; MALE; THROUGH HOLE; SQUARE POST HEADER; RIGHT ANGLE; 12PINS ;
26	JMP1-JMP4, JMP6-JMP9	—	8	PEC04SAAN	SULLINS ELECTRONICS CORP.	PEC04SAAN	CONNECTOR; MALE; THROUGH HOLE; BREAKAWAY; STRAIGHT; 4PINS
27	L1	—	1	XAL4020-601ME	COILCRAFT	0.60UH	INDUCTOR; SMT; CORE MATERIAL= COMPOSITE; 0.60UH; TOL = ±20%; 11.7A
28	L2	—	1	MSS1246T-472ML	COILCRAFT	4.7UH	INDUCTOR; SMT; FERRITE CORE; 4.7UH; TOL = ±20%; 9.70A
29	Q1	—	1	NDS351AN	FAIRCHILD SEMICONDUCTOR	NDS351AN	TRAN; N-CHANNEL LOGIC LEVEL ENHANCEMENT MODE FIELD EFFECT TRANSISTOR; NCH; SUPERSOT-3; PD-(0.5W); I(-1.4A); V(-30V)
30	Q2	—	1	MMBT3906-7-F	DIODES INCORPORATED	MMBT3906-7-F	TRAN; 40V PNP SMALL SIGNAL TRANSISTOR; PNP; SOT-23; PD-(0.31W); I(-0.2A); V(-40V)
31	Q3	—	1	SUM55P06-19L-E3	VISHAY SILICONIX	SUM55P06-19L-E3	TRAN; P-CHANNEL 60V D-S ENHANCEMENT MODE MOSFET; PCH; TO-263-3; PD-(3.75W); I(-55A); V(-60V)
32	Q4	—	1	NVMF55C677NLT1G	ON SEMICONDUCTOR	NVMF55C677NLT1G	TRAN; NCH; POWER MOSFET; SO-8FL; PD-(3.5W); I(-36A); V(-60V)
33	Q5	—	1	SI1317DL-T1-GE3	VISHAY SILICONIX	SI1317DL-T1-GE3	TRAN; P-CHANNEL 20V (D-S) MOSFET; PCH; SOT-323; PD-(0.5W); I(-1.4A); V(-20V)
34	R2	—	1	CRCW06033K00FK	VISHAY DALE	3K	RESISTOR; 0603; 3KΩ; 1%; 100PPM; 0.10W; THICK FILM
35	R3, R7	—	2	CRCW08050000ZS; ERJ-8GEY0R00; RC2012J000; RMCFO805ZTOR00	DIGI-KEY	0	RESISTOR; 0805; 0Ω; JUMPER; 0.125W; THICK FILM
36	R4	—	1	CRCW0805226KFK	VISHAY DALE	226K	RESISTOR; 0805; 226KΩ; 1%; 100PPM; 0.125W; THICK FILM
37	R5	—	1	TNPW080510K0BE; ERA-6YEB103V	VISHAY DALE; PANASONIC	10K	RESISTOR; 0805; 10KΩ; 0.1%; 25PPM; 0.125W; THIN FILM
38	R6	—	1	301-10K-RC	XICON	10K	RESISTOR; 0603; 10KΩ; 5%; 200PPM; 1/16W; THICK FILM
39	R8	—	1	CRCW12060000ZS; ERJ-8GEY0R00	VISHAY DALE; PANASONIC	0	RESISTOR; 1206; 0Ω; 0%; JUMPER; 0.25W; THICK FILM
40	R9	—	1	CRCW06031M00FK; MCR03EZPFX1004	VISHAY DALE; ROHM	1M	RESISTOR; 0603; 1MΩ; 1%; 100PPM; 0.10W; THICK FILM
41	R11	—	1	CRCW060318K0FK	VISHAY DALE	18K	RESISTOR; 0603; 18KΩ; 1%; 100PPM; 0.10W; THICK FILM
42	R13	—	1	RC0603FR-0784KSL	YAGEO PHYCOMP	84.5K	RESISTOR; 0603; 84.5KΩ; 1%; 100PPM; 0.10W; THICK FILM
43	R14	—	1	ERJ-8CWF0R050	PANASONIC	0.05	RESISTOR; 1206; 0.05Ω; 1%; 75PPM; 1W; THICK FILM
44	R15, R49	—	2	RG1608N-102-B-T1	SUSUMU CO LTD.	1K	RESISTOR; 0603; 1KΩ; 0.1%; 10PPM; 0.10W; THICK FILM
45	R16, R53	—	2	ERJ-3EKF5902	PANASONIC	59K	RESISTOR; 0603; 59KΩ; 1%; 100PPM; 0.1W; THICK FILM
46	R18, R21	—	2	ERJ-3EKF2742	PANASONIC	27.4K	RESISTOR; 0603; 27.4KΩ; 1%; 100PPM; 0.1W; THICK FILM

MAX20444B Evaluation Kit

Evaluates: MAX20444B/
MAX20444C

MAX20444B EV Kit Bill of Materials (continued)

ITEM	REF_DES	DN/DNP	QTY	MFG PART #	MANUFACTURER	VALUE	DESCRIPTION
47	R20	—	1	CRCW060318K7FK	VISHAY DALE	18.7K	RESISTOR; 0603; 18.7KΩ; 1%; 100PPM; 0.1W; THICK FILM
48	R22, R25, R29, R36, R38, R45	—	6	CRCW060312K0FK	VISHAY DALE	12K	RESISTOR; 0603; 12KΩ; 1%; 100PPM; 0.10W; THICK FILM
49	R23, R34, R37, R43	—	4	CRCW0603100KFK; RC0603FR-07100KL; RC0603FR-13100KL; ERJ-3EKF1003; AC0603FR-07100KL	VISHAY DALE;YAGEO; YAGEO;PANASONIC	100K	RESISTOR; 0603; 100K; 1%; 100PPM; 0.10W; THICK FILM
50	R24	—	1	CRCW06033K74FK	VISHAY DALE	3.74K	RESISTOR; 0603; 3.74KΩ; 1%; 100PPM; 0.1W; THICK FILM
51	R26	—	1	CRCW060322R0JN	VISHAY DALE	22	RESISTOR; 0603; 22Ω; 5%; 200PPM; 0.10W; THICK FILM
52	R27	—	1	WSL1206R0400F	VISHAY DALE	0.04	RESISTOR; 1206; 0.04Ω; 1%; 75PPM; 0.25W; THICK FILM
53	R28	—	1	ERJ-3EKF7151	PANASONIC	7.15K	RESISTOR; 0603; 7.15KΩ; 1%; 100PPM; 0.10W; THICK FILM
54	R30, R54	—	2	ERJ-3EKF3481	PANASONIC	3.48K	RESISTOR; 0603; 3.48KΩ; 1%; 100PPM; 0.1W; THICK FILM
55	R32	—	1	CRCW060339K0FK	VISHAY DALE	39K	RESISTOR; 0603; 39KΩ; 1%; 100PPM; 0.10W; THICK FILM
56	R35	—	1	CRCW06038K06FK; ERJ-3EKF8061	VISHAY DALE;PANASONIC	8.06K	RESISTOR; 0603; 8.06KΩ; 1%; 100PPM; 0.1W; THICK FILM
57	R39	—	1	CRCW060376K8FK	VISHAY DALE	76.8K	RESISTOR; 0603; 76.8KΩ; 1%; 100PPM; 0.10W; THICK FILM
58	R40	—	1	CRCW06033012FK	VISHAY DALE	30.1K	RESISTOR; 0603; 30.1K; 1%; 100PPM; 0.10W; THICK FILM
59	R41	—	1	CRCW060320K0FK	VISHAY DALE	20K	RESISTOR; 0603; 20KΩ; 1%; 100PPM; 0.1W; THICK FILM
60	R42, R46, R55	—	3	CHPHT0603K1002FGT	VISHAY SFERNICE	10K	RESISTOR; 0603; 10KΩ; 1%; 100PPM; 0.0125W; THICK FILM
61	R44	—	1	CRCW060349K9FK; ERJ-3EKF4992	VISHAY DALE;PANASONIC	49.9K	RESISTOR; 0603; 49.9KΩ; 1%; 100PPM; 0.10W; THICK FILM
62	R46, R47	—	2	CRCW06034K70FK	VISHAY DALE	4.7K	RESISTOR; 0603; 4.7K; 1%; 100PPM; 0.10W; THICK FILM
63	R50	—	1	CRCW06031K40FK	VISHAY DALE	1.4K	RESISTOR; 0603; 1.4KΩ; 1%; 100PPM; 0.1W; THICK FILM
64	R51	—	1	RN73C1J10RBTG; 1614350-2	TE CONNECTIVITY; TE CONNECTIVITY	10	RESISTOR; 0603; 10Ω; 0.1%; 10PPM; 0.063W; THICK FILM
65	R52	—	1	CRCW060313K3FK; ERJ-3EKF1332	VISHAY DALE;PANASONIC	13.3K	RESISTOR; 0603; 13.3KΩ; 1%; 100PPM; 0.1W; THICK FILM
66	U1	—	1	MAX20444BATGV+	MAXIM	MAX20444BATGV+	EVKIT PART-IC; MAX20444BATGV+; PKG. OUTLINE DWG. NO.: 21-0139; LAND PATTERN NUMBER: 90-0022; PKG. CODE: T2444-4C
67	PCB	—	1	MAX20444	MAXIM	PCB	PCB:MAX20444
68	C1, C19, C3	DNP	0	N/A	N/A	OPEN	CAPACITOR; SMT (0603); OPEN; FORMFACTOR
69	C7, C8	DNP	0	C1210C475K5RAC; GRM32ER71H475KA88; GRM32ER71H475KA88; GCM32ER71H475KA55; CGA6P3X7R1H475K250AB	KEMET;MURATA; MURATA;MURATA;TDK	4.7UF	CAPACITOR; SMT (1210); CERAMIC CHIP; 4.7UF; 50V; TOL = 10%; TG = -55°C TO +125°C; TC = X7R
70	C15, C30, C32	DNP	0	C2012X7R1H225K125AC; CGA4J3X7R1H225K125AB; CGA4J3X7R1H225K125AE	TDK;TDK;TDK	2.2UF	CAPACITOR; SMT (0805); CERAMIC CHIP; 2.2UF; 50V; TOL=10%; TG = -55°C TO +125°C; TC = X7R
71	L3	DNP	0	XAL5050-103ME	COILCRAFT	10UH	INDUCTOR; SMT; COMPOSITE CORE; 10UH; TOL = ±20%; 4.9A
72	R1, R33	DNP	0	N/A	N/A	OPEN	RESISTOR; 0603; OPEN; FORMFACTOR
73	R56	DNP	0	CRCW12060000ZS; ERJ-8GEY0R00	VISHAY DALE; PANASONIC	0	RESISTOR; 1206; 0Ω; 0%; JUMPER; 0.25W; THICK FILM
74	C29	DNP	0	N/A	N/A	OPEN	EVKIT USE ONLY; DUAL PACKAGE OUTLINE 0603 AND 0805 NON-POLAR CAPACITOR
75	R31	DNP	0	N/A	N/A	OPEN	RESISTOR; 1206; OPEN; FORMFACTOR
TOTAL			146				

MAX20444B EV Kit Schematics

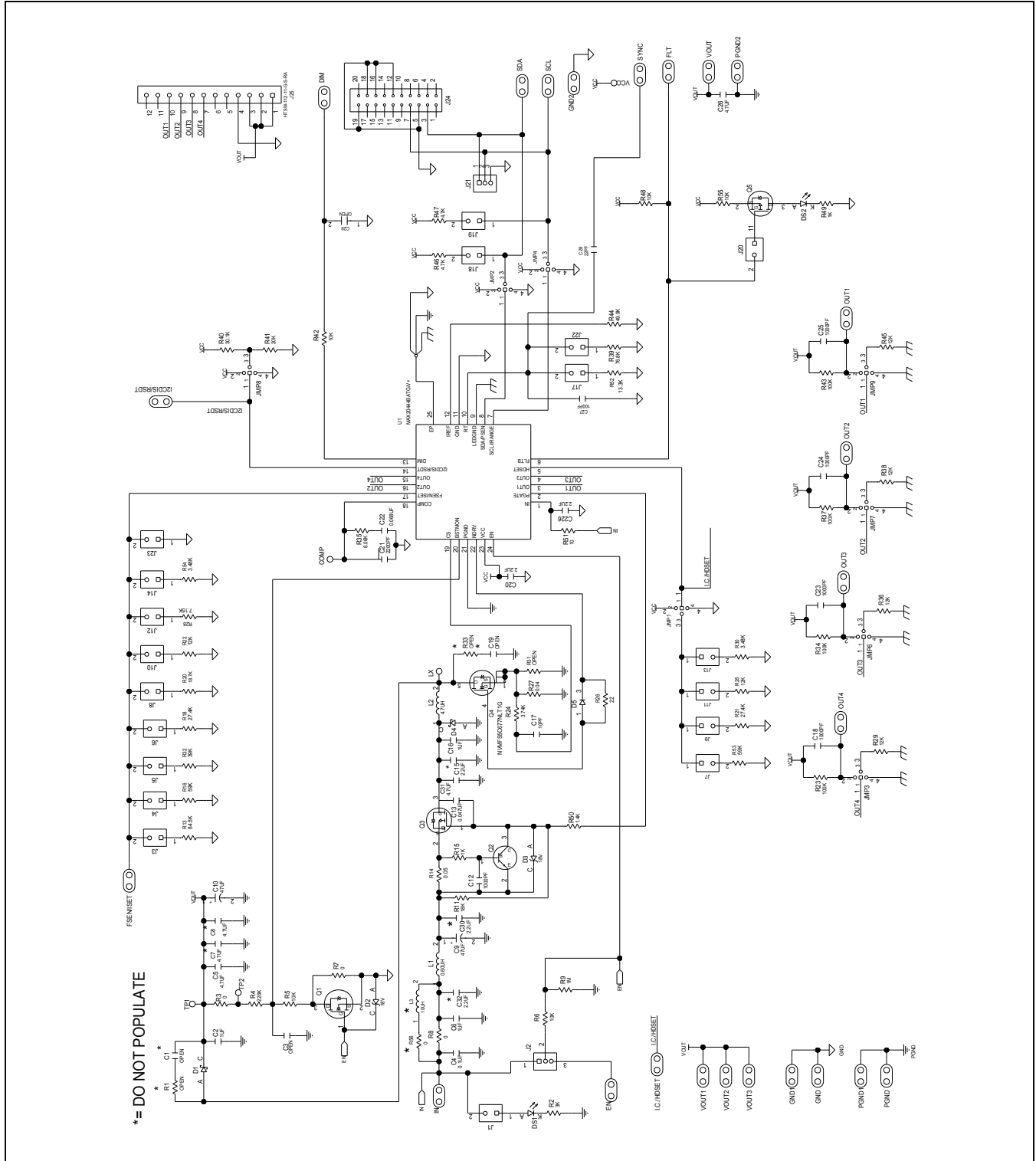

MAX20444B EV Kit PCB Layout Diagrams

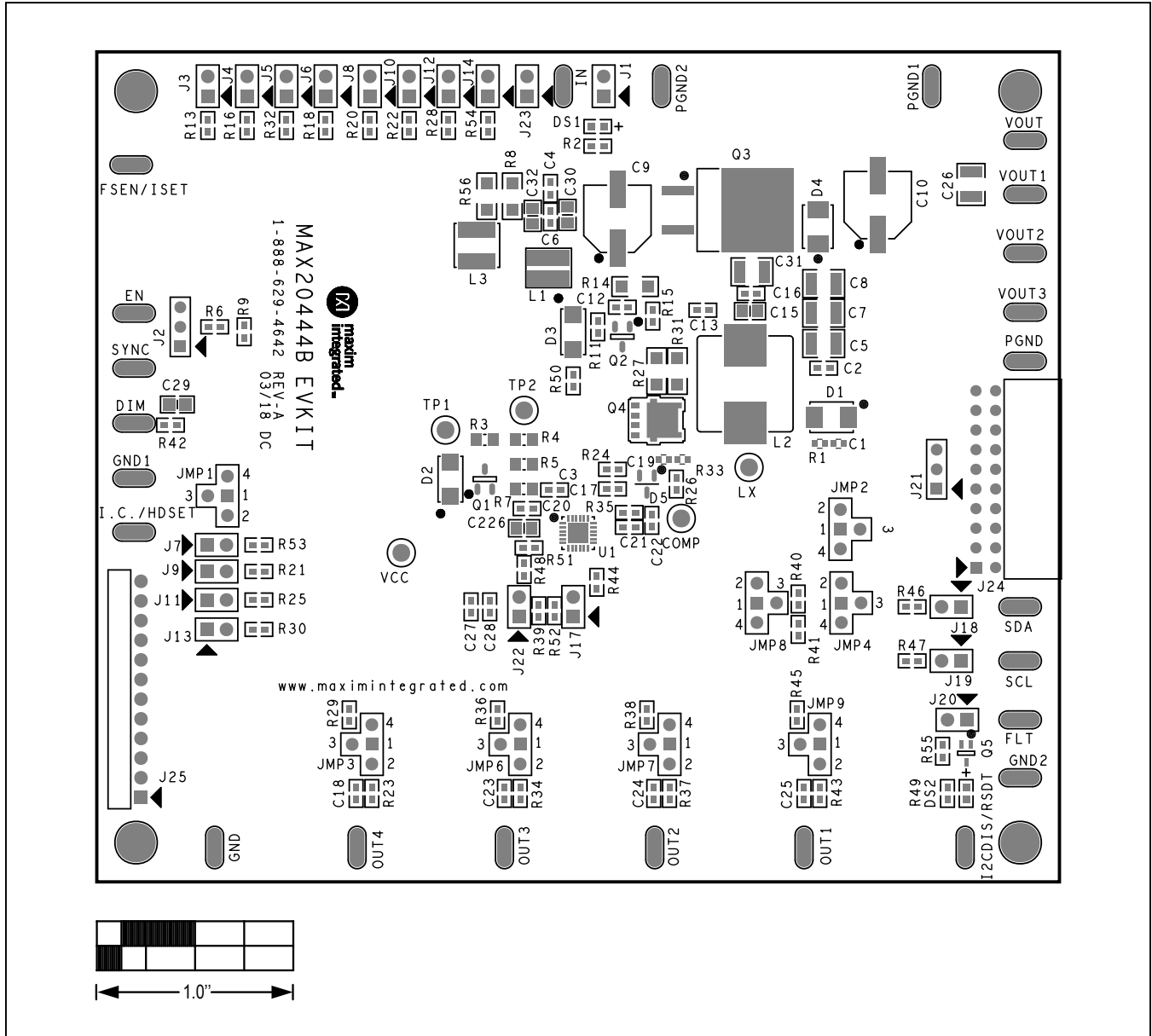

MAX20444B EV Kit Component Placement Guide—Top Silkscreen

MAX20444B EV Kit PCB Layout Diagrams (continued)

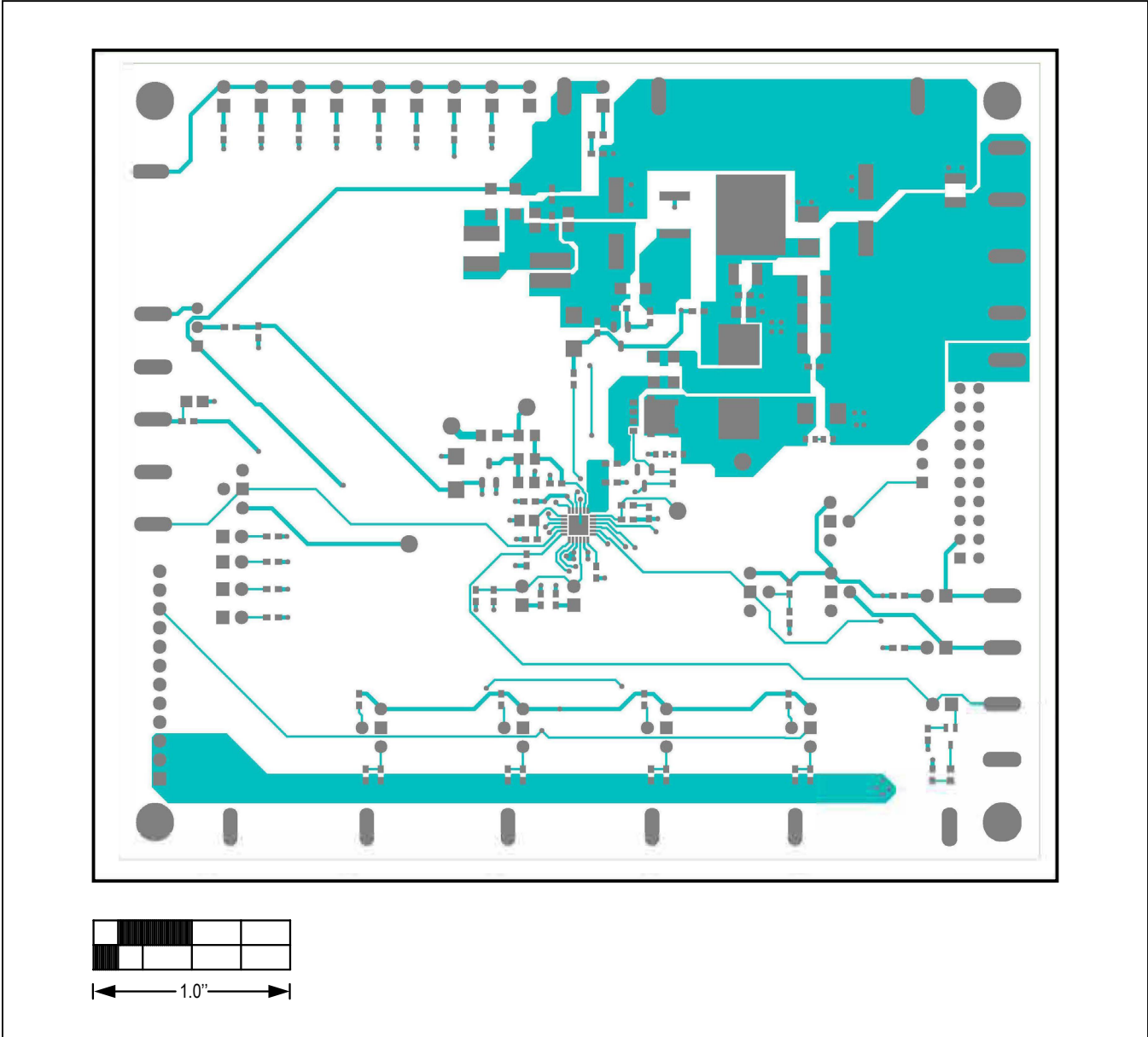

MAX20444B EV Kit PCB Layout—Top Layer

MAX20444B EV Kit PCB Layout Diagrams (continued)

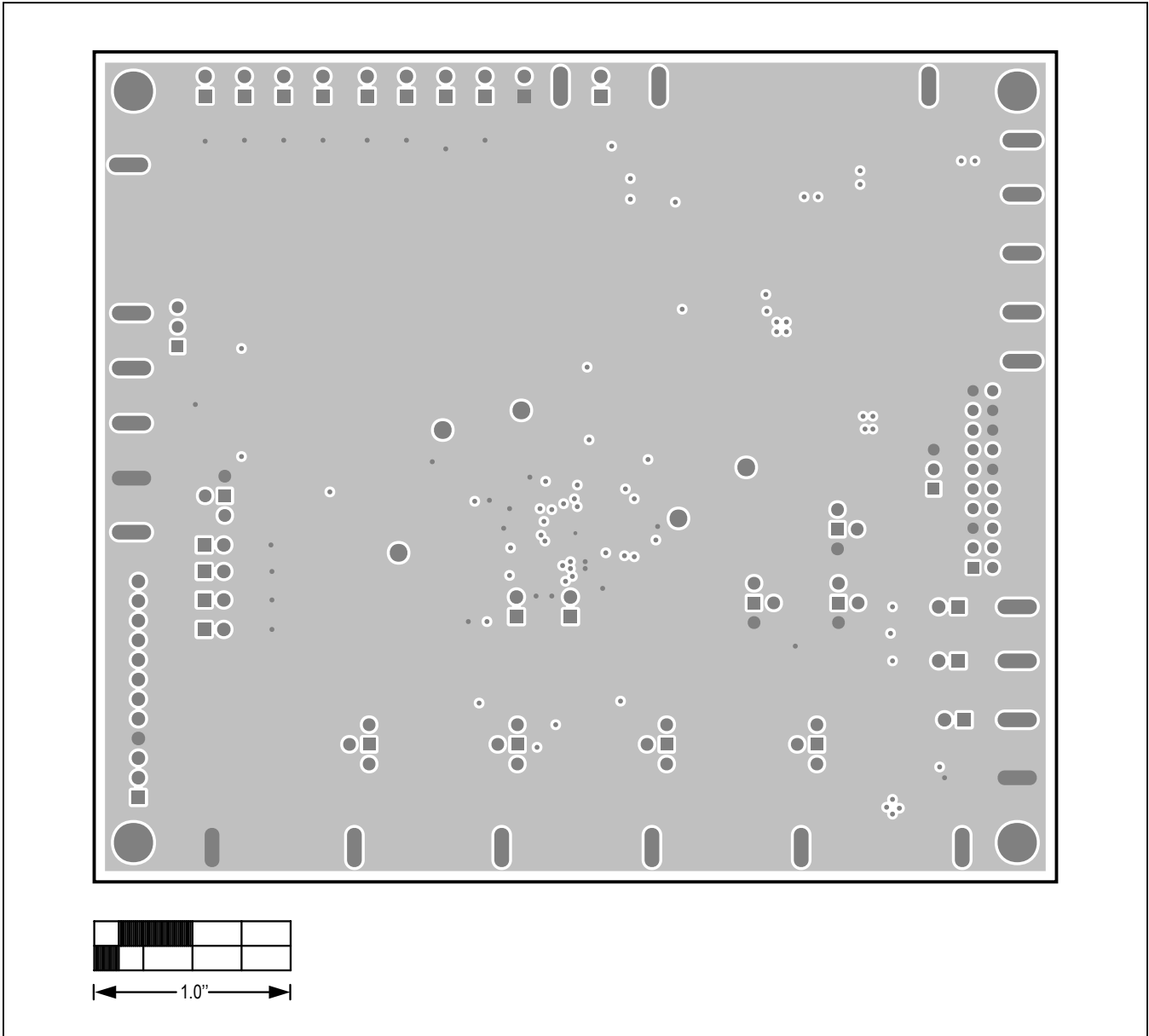

MAX20444B EV Kit PCB Layout—Internal Layer 2

MAX20444B EV Kit PCB Layout Diagrams (continued)

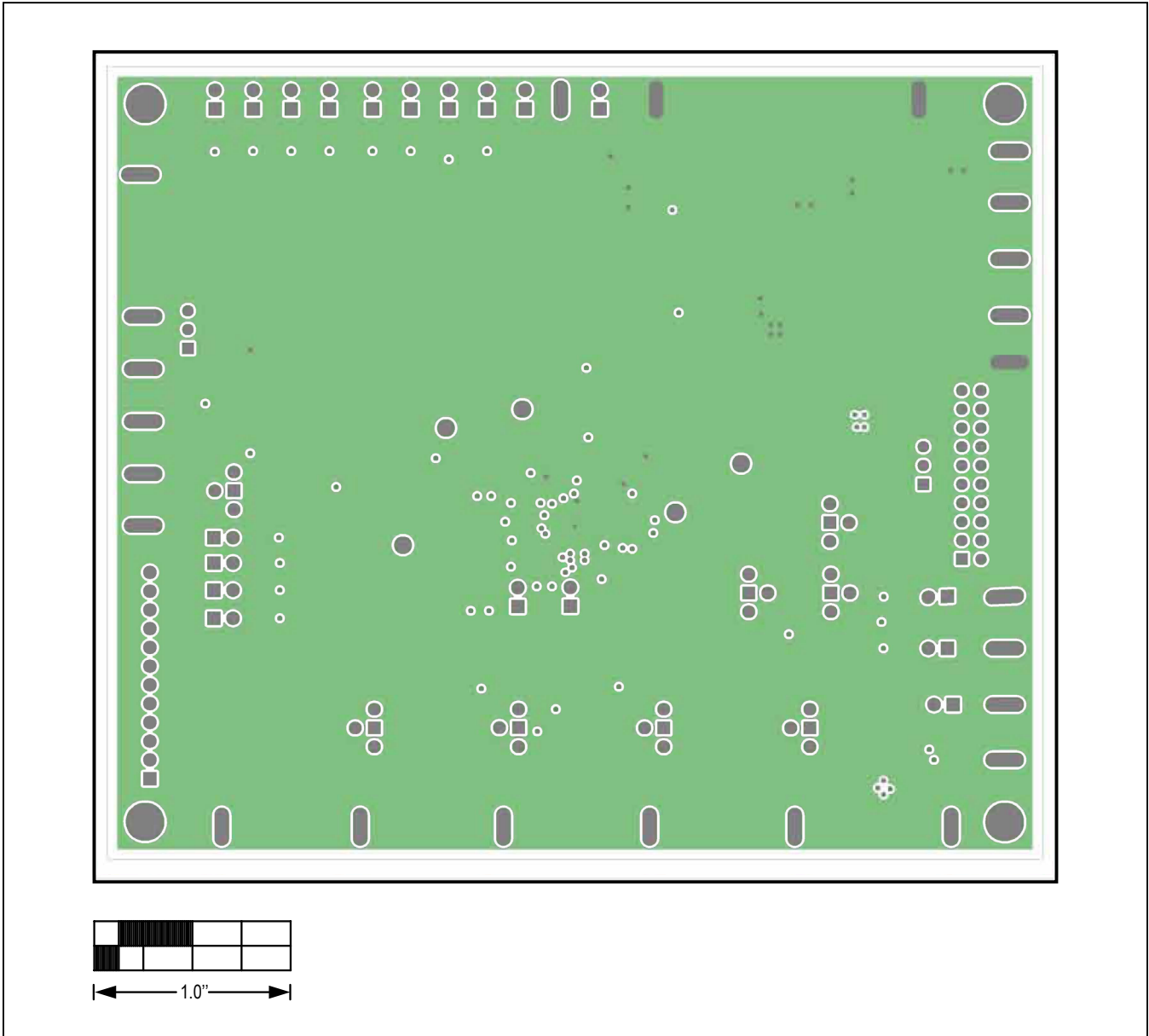

MAX20444B EV Kit PCB Layout—Internal Layer 3

MAX20444B EV Kit PCB Layout Diagrams (continued)

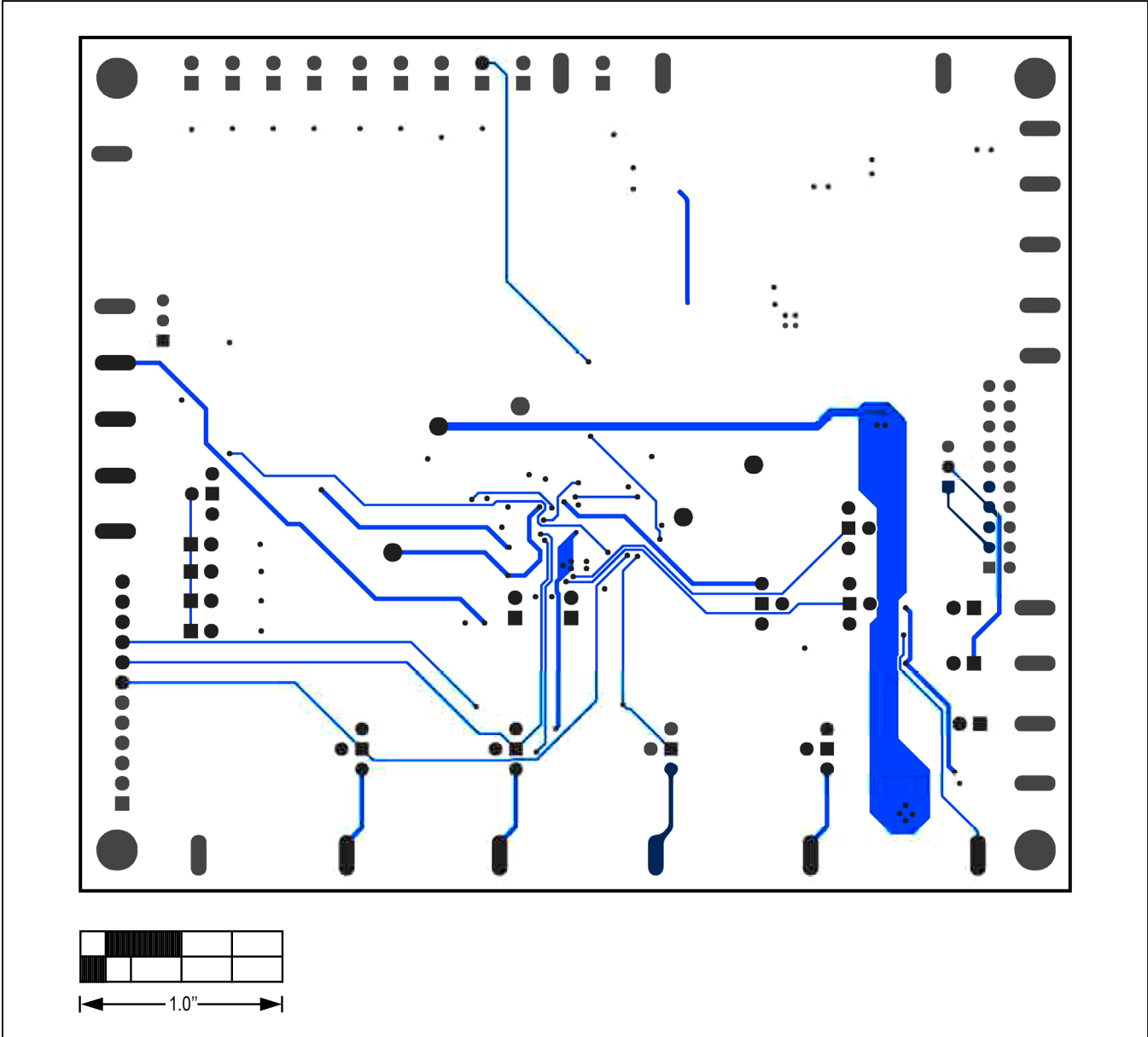

MAX20444B EV Kit PCB Layout—Bottom Layer

Revision History

REVISION NUMBER	REVISION DATE	DESCRIPTION	PAGES CHANGED
0	3/19	Initial release	—
1	9/21	Added MAX20444C to title; updated Table 7	All



Information furnished by Analog Devices is believed to be accurate and reliable. However, no responsibility is assumed by Analog Devices for its use, nor for any infringements of patents or other rights of third parties that may result from its use. Specifications subject to change without notice. No license is granted by implication or otherwise under any patent or patent rights of Analog Devices. Trademarks and registered trademarks are the property of their respective owners.

Looking for pricing, stock, or lifecycle information?

Click below to explore more details on WIN SOURCE:

 [View LP0002/01-LI98-0.25 on WIN SOURCE](#)

 [t-Global Technology Information](#)

Optimize Your Supply Chain with WIN SOURCE Solutions

-  Global Sourcing Solution
-  Obsolete Management
-  Cost Control Management
-  Shortage Management
-  Alternative Solution
-  Excess Inventory Management