



# THE DATASHEET OF TPS61197EVM



## **TPS92602 Evaluation Module (EVM)**

The TPS92602EVM evaluation module (EVM) helps designers evaluate the operation and performance of the TPS92602-Q1 two-channel high-side current-sense dc-dc MOSFET controller. The TPS92602-Q1, designed to drive automotive high-brightness light-emitting diodes (LEDs), features a wide input-voltage range (4.5 V to 40 V), high-side current sense, a precision reference, switching-frequency synchronization, analog dimming, PWM dimming, and full diagnostics including high-side current (LED current) available as analog output, open-LED and short-to-GND detection, and shorted-output protection.

### **Contents**

1	Detailed Description .....	2
	1.1 Description .....	2
	1.2 Typical Applications .....	2
	1.3 Features .....	2
2	Electrical Performance Specifications .....	7
3	Schematic .....	8
4	Performance Data and Typical Characteristic Curves .....	9
	4.1 Efficiency .....	9
	4.2 Line Regulation .....	9
	4.3 Switching Frequency .....	9
	4.4 Switch-Node Voltage and LED Current Ripple .....	10
	4.5 Start-Up and Shut-Down Response .....	12
	4.6 Thermal Performance .....	13
5	TPS92602EVM PCB Layout .....	15
6	Bill of Materials .....	18

### **List of Figures**

1	DIAGx Terminal Function .....	5
2	Analog Dimming – ICTRLx Terminal .....	6
3	Boost Efficiency versus Input Voltage.....	9
4	Line Regulation.....	9
5	Switching Frequency versus $R_{(RT)}$ Resistance.....	9
6	Switching and LED Current Ripple When $I_{out} = 500$ mA .....	10
7	PWM Dimming, $f_{PVM} = 200$ Hz, Duty Cycle = 50%.....	10
8	PWM Dimming, $f_{PVM} = 200$ Hz, Duty Cycle = 5% .....	11
9	PWM Dimming, $f_{PVM} = 200$ Hz, Duty Cycle = 95%.....	11
10	Start-Up Waveform .....	12
11	Shut-Down Waveform.....	12
12	Top Thermal Performance .....	13
13	Bottom Thermal Performance .....	14
14	3D Board View .....	15
15	PCB Top Layer .....	16
16	PCB Bottom Layer .....	17

### **List of Tables**

1	TPS926902EVM Electrical Performance Specifications .....	7
---	--	---

2	Bill of Materials.....	18
---	------------------------	----

## 1 Detailed Description

### 1.1 Description

The TPS92602-Q1 is a dual-channel LED driver. The basis for each independent driver is a peak-current-mode boost controller. Each controller has a current feedback loop with high-side current-sensing shunt and a voltage-feedback loop with an external resistor-divider network. Each controller has two independent feedback loops, a current-feedback loop with high-side current-sensing shunt and a voltage-feedback loop with an external resistor-divider network. The controller delivers a constant output voltage or a constant output current. The connected load determines whether the board is regulating a constant output current (if current set point is reached earlier than voltage set point) or a constant output voltage (if the voltage set point is reached first, for example in an open-load condition).

Each controller supports all typical topologies like boost, boost to battery, SEPIC, or flyback.

Uses for the high-side PMOS FET driver are for PWM dimming of the LED string and for cutoff in case of an external short circuit to GND in order to protect the circuit.

### 1.2 Typical Applications

This converter design describes an application of the TPS92602-Q1 as an LED driver for the boost and boost-to-battery applications. For applications with a different input voltage range or different output voltage range, see the TPS92602-Q1 data sheet ([SLUSBP5](#)).

### 1.3 Features

#### 1.3.1 Connector Description

This section describes the connectors, jumpers, and test points on the EVM and how to properly connect, set up, and use the TPS92602EVM.

#### 1.3.2 J\_VBAT1, J\_VBAT2

J\_VBAT1 is the CH1 input and J\_VBAT2 is the CH2 input.

#### 1.3.3 J-PGND

J\_PGND is a common GND for the input.

#### 1.3.4 J\_B1\_OUT, J\_B2\_OUT

J\_B1\_OUT is the output of CH1; connect LED+ to this connector. J\_B2\_OUT is output of CH2; connect LED+ to this connector.

#### 1.3.5 J\_B1\_GND, J\_B2\_GND

J\_B1\_GND is the output GND of CH1; connect LED- to this connector. J\_B2\_OUT is the output GND of CH2; connect LED- to this connector.

#### 1.3.6 CN1, CN3

CN1 is the PWM input for CH1 and CN3 is the PWM input for CH2.

#### 1.3.7 CN2, CN4

CN2 is the output of DIAG1 and CN4 is the output of DIAG2.

### 1.3.8 P1

Jumper for TPS92602-Q1 VIN; connect it before power on.

### 1.3.9 P2

Jumper for TPS7A6650-Q1 Vin; connect it when in need of an LDO in the EVM to generate 5 V for Ictrl and PWM.

### 1.3.10 P3

Jumper for TPS7A6650-Q1 Vout; connect it when in need of an LDO in the EVM to generate 5 V for Ictrl and PWM.

### 1.3.11 P4

Connect P4 terminal 1 with P4 terminal 2 to enable the TPS7A6650-Q1, and connect P4 terminal 2 with P4 terminal 3 to disable the TPS7A6650-Q1.

### 1.3.12 P\_RT

Connect P\_RT terminal 1 with P\_RT terminal 2 to set the RT resistor as 20 kΩ, or input PWM on P\_RT terminal 2 for direct frequency synchronization.

The switching frequency is adjustable over a range from 100 kHz to 600 kHz by placing a resistor on the RT terminal. The RT terminal voltage is typically 0.5 V and must have a resistor to ground to set the switching frequency. To determine the timing resistance for a given switching frequency, use [Equation 1](#) or [Figure 5](#). To reduce the solution size, one would typically set the switching frequency as high as possible, but consider tradeoffs of the supply efficiency, maximum input voltage, and minimum controllable on-time.

$$R_{(RT)}[\text{k}\Omega] = \frac{12.5 \text{ MHz} \times 1 \text{ k}\Omega}{f_{(OSC)}[\text{MHz}]} \quad (1)$$

One can also use the RT terminal to synchronize the controllers to an external system clock, over a range from 100 kHz to 600 kHz. Use this synchronization feature by applying a square wave to the RT terminal. The square wave must transition lower than 0.8 V and higher than 2 V on the RT terminal and have an on-time greater than 70 ns and an off-time greater than 70 ns. The synchronization frequency range is 100 kHz to 600 kHz. The rising edge of GDRV1 synchronizes with the falling edge of the RT terminal signal.

Leaving the RT terminal open or shorted to ground, with no external system clock signal present, disables both boost controllers and switches off both PWM dimming FETs. In order to recover from this global failure state, (for example, after removal of the failure condition on the RT terminal) there must be one global disable-and-enable cycle (active shutdown by pulling both P\_PWMx terminals low for  $t > t_{(CH\_OFF)}$ , and setting one or both PWMINx terminals high for  $t > t_{(CH\_ON)}$ ).

### 1.3.13 P\_PWM1, P\_PWM2

Connect P\_PWM1 terminal 1 with P\_PWM1 terminal 2 to set the CH1 PWM dimming duty cycle to 100%, connect P\_PWM1 terminal 2 with P\_PWM1 terminal 3 to disable CH1, or input PWM directly to P\_PWM1 terminal 2 to control the dimming duty cycle. Connect P\_PWM2 terminal 1 with P\_PWM2 terminal 2 to set the CH2 PWM dimming duty cycle to 100%, connect P\_PWM2 terminal 2 with P\_PWM2 terminal 3 to disable CH2, or input PWM directly to P\_PWM2 terminal 2 to control the dimming duty cycle.

In order to change the brightness of an LED string to a certain luminosity without affecting the lighting color of the LED, it is necessary to use PWM dimming topology. Turning the LEDs ON and OFF at a certain frequency with a certain duty cycle reduces the brightness without changing the LED current (so not affecting the color).

The integrated high-side PMOS-FET gate driver turns the LED string ON and OFF following the supplied signal frequency and duty cycle on the PWMIN terminal. During the OFF time of the FET, the internal control loop stops, and the device stores the value of the compensation network by disconnecting the amplifier internally. This technique allows the fastest recovery of the regulator during the following on-time, as the control loop restarts from the point at which it stopped. The average LED current during the on-time is almost the same as the LED current with no PWM dimming (the duty cycle is 100%). For very low duty cycles, the time for the controller to ramp up the inductor current from 0 A is more significant relative to the overall on-time, leading to lower average current. So for very low duty cycles, the relation between average current and duty cycle is no longer linear.

Maintaining a minimum on-time is necessary in order for PWM dimming to operate in the linear region of its transfer function. Because of the disabled state of the controller during dimming, the PWM pulse must be long enough that the energy intercepted from the input is greater than or equal to the energy being put into the LEDs. For boost and boost-to-battery topologies, the minimum on-time (in seconds) for which the PWM dimming operates in the linear region is given by:

$$t_{(\text{PWMON\_MIN})} = \frac{2 \times I_{(\text{LED})} \times V_{(\text{out})} \times L}{V_{(\text{in})}^2} \quad (2)$$

In order to ensure that the applied dimming-pulse duration matches with the effective dimming-pulse duration, TI recommends synchronizing the dimming pulses with the switching clock of the boost converter. Choose an external inductor and output capacitors according to the requirements for the minimum duty cycle.

#### 1.3.14 P1, P\_VBAT1 and P\_VBAT2

Connect P1, P\_VBAT1, and P\_VBAT2 as necessary to meet the input requirements for VIN on the TPS92602-Q1.

#### 1.3.15 TP\_AGND1, TP\_AGND2

Test points for AGND1 and AGND2

#### 1.3.16 TP\_B1, TP\_B2

Test points for CH1 and CH2 GND

#### 1.3.17 TP\_COMP1, TP\_COMP2

Test points for the COMP1 and COMP2 terminals

#### 1.3.18 TP\_DIAG1, TP\_DIAG2

Test points for the DIAG1 and DIAG2 terminals

In regular operation mode, an external microcontroller can measure the actual output current of the controller by sensing the voltage at the DIAGx terminal. A DIAGx terminal voltage between 0.2 V and 2.85 V represents in a linear relation the output current measured by the current-sense block over the external shunt resistor. Parameter DIAGfactor gives the scale factor of typically 16 (TPS92601-Q1 or TPS92602-Q1 with 150-mV full-scale current-sense voltage) or 8 (TPS92601A-Q1 or TPS92602A-Q1 with 300-mV full-scale current-sense voltage). [Figure 1](#) shows the relation between the DIAGx terminal voltage and the current-sense voltage.

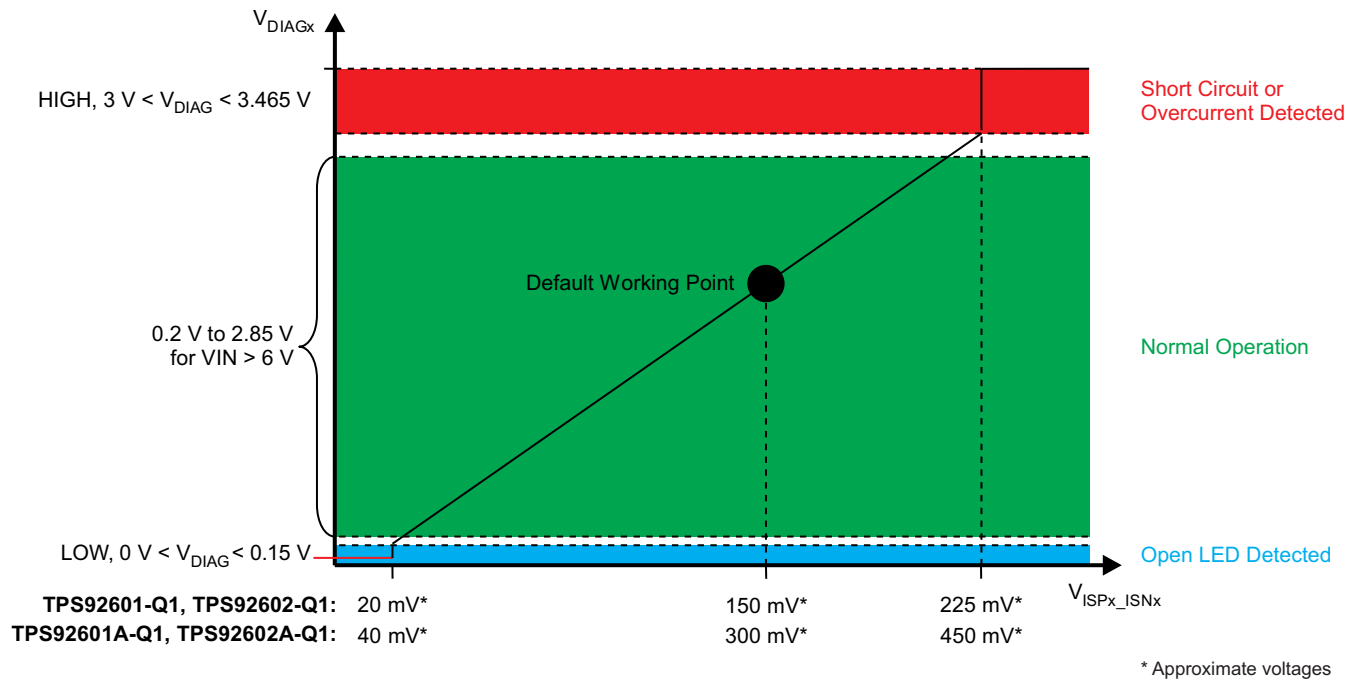

Figure 1. DIAGx Terminal Function

### 1.3.19 TP\_ICTRL1, TP\_ICTRL2

Test points for the ICTRL1 and ICTRL2 terminals. Adjust R12 and R27 to set the ICTRL voltage. An analog voltage applied to the ICTRLx terminal allows changing the output current for each channel on the fly from 10% to 100% of full scale. Typically, this approach is used to:

- Reduce the default current in a narrow range to adjust to different binning classes of LEDs
- Reduce the current at high temperatures (protect LEDs from overtemperature)
- Reduce the current at low input voltages (for example, cranking-pulse breakdown of the supply)

Implementing this analog dimming function is possible with an analog approach [discrete resistor and negative-temperature-coefficient (NTC) network] or with a more flexible approach by using a microcontroller. In order to simplify the analog implementation, the device clamps the maximum voltage at the ICTRLx terminal internally at 1.5 V. So, applying any higher voltage has no effect on the output current (which sticks to its current set point at 100% of full scale, that is, approximately 150 mV or 300 mV drop at the external current-shunt resistor).

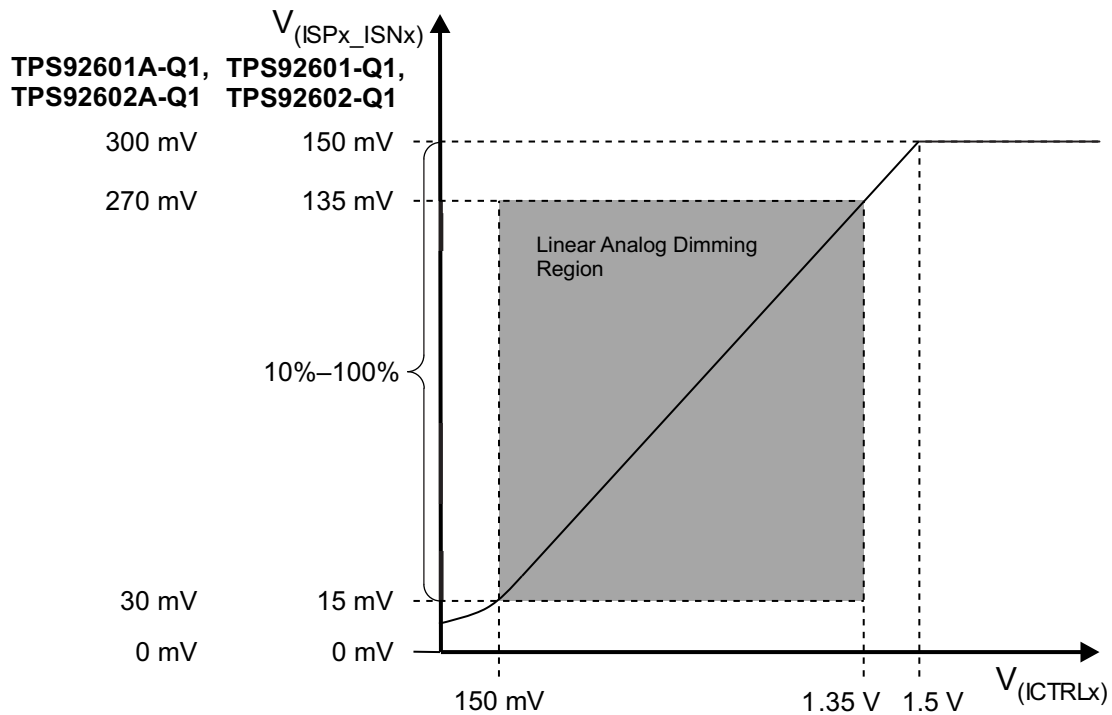
**Figure 2. Analog Dimming – ICTRLx Terminal**

### 1.3.20 TP\_PWMIN1, TP\_PWMIN2

Test points for the PWMIN1 and PWMIN2 terminals

### 1.3.21 TP\_RT

Test point for the RT terminal

### 1.3.22 TP\_VFB1, TP\_VFB2

Test points for the VFB1 and VFB2 terminals. Adjust R032 and R102 to set the OVP voltage.

### 1.3.23 TP\_VIN\_D

Test point for TPS92602-Q1  $V_{(VIN)}$

## 2 Electrical Performance Specifications

**Table 1. TPS926902EVM Electrical Performance Specifications**

PARAMETER	TEST CONDITIONS	MIN	TYP	MAX	UNIT
<b>INPUT CHARACTERISTICS</b>					
Voltage range		5.86		40	V
Maximum input current	At $I_{(OUT)} = 500$ mA		2.49		A
Undervoltage lockout level	Input rising		5.38		V
	Input falling		3.84		V
<b>WITH 10 LEDs IN SERIES</b>					
Output voltage, $V_{(OUT)}$	At $I_{(OUT)} = 500$ mA		27.4		V
Output load current, $I_{(OUT)}$	$V_{(ICTRLx)} = 0$ V to 1.5 V	0	250	499.7	mA
Output current regulation	Line regulation: input voltage = 8 V to 19 V		0.38%		
Output current ripple	At $I_{(OUT)} = 500$ mA		8.4		mApp
Overvoltage protection level	Output rising		36		V
<b>SYSTEMS CHARACTERISTICS</b>					
Switching frequency			589		kHz
Efficiency	Input voltage = 12 V, Load = 10 LEDs at 500 mA		92.51%		
PWM dimING frequency		200		2000	Hz

### 3 Schematic

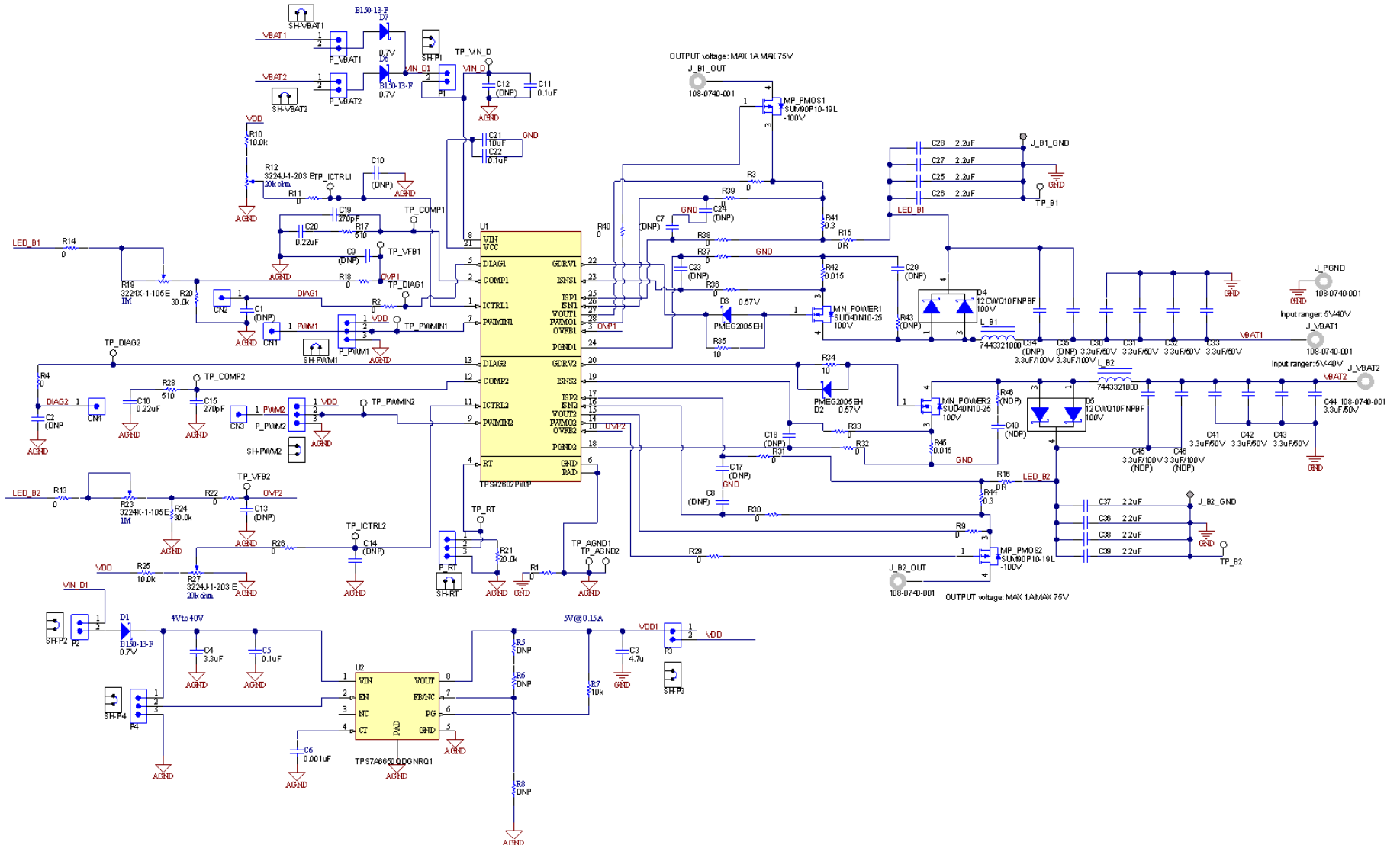

## 4 Performance Data and Typical Characteristic Curves

### 4.1 Efficiency

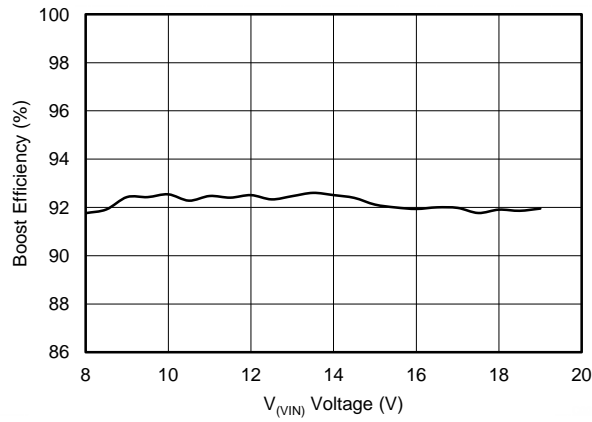

Figure 3. Boost Efficiency versus Input Voltage

### 4.2 Line Regulation

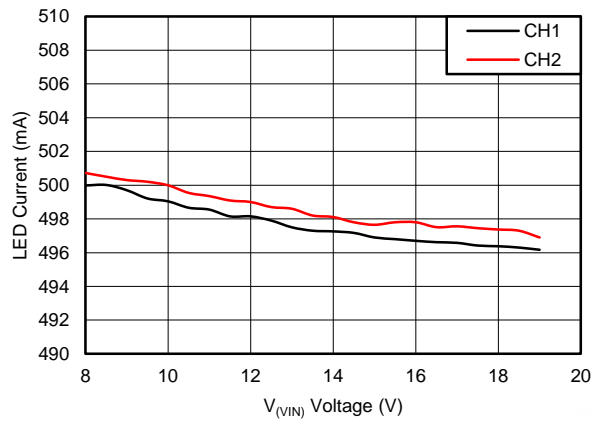

Figure 4. Line Regulation

### 4.3 Switching Frequency

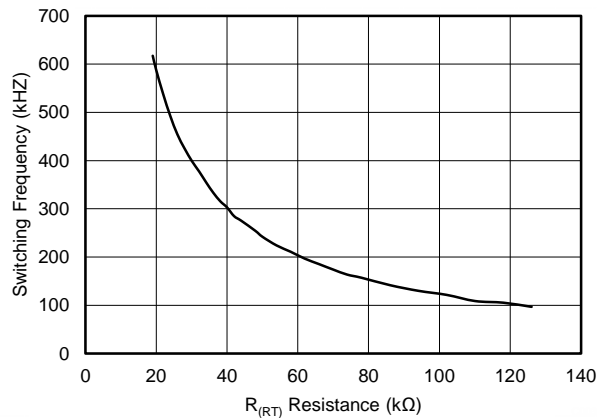

Figure 5. Switching Frequency versus R<sub>(RT)</sub> Resistance

#### 4.4 Switch-Node Voltage and LED Current Ripple

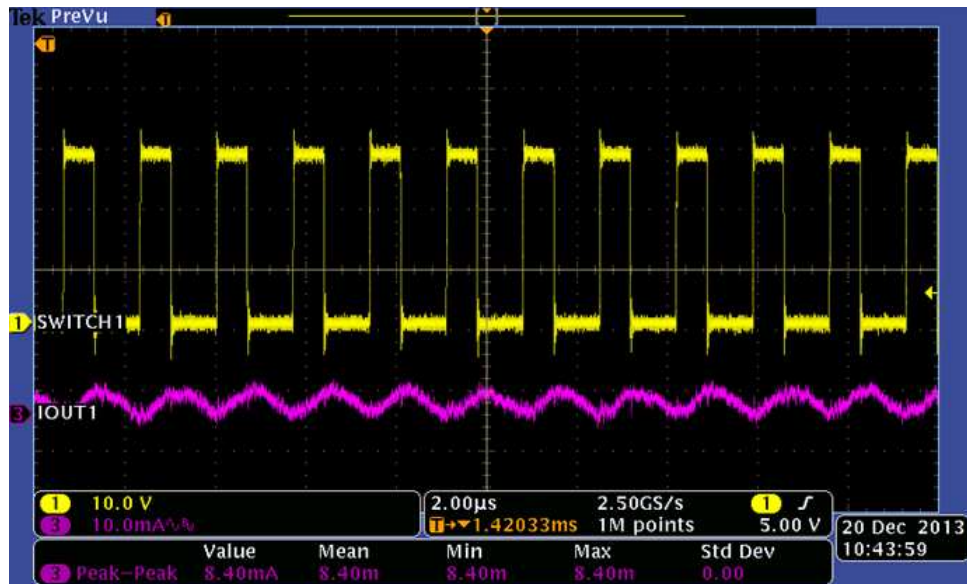

Figure 6. Switching and LED Current Ripple When  $I_{out} = 500\text{ mA}$

#### PWM Dimming

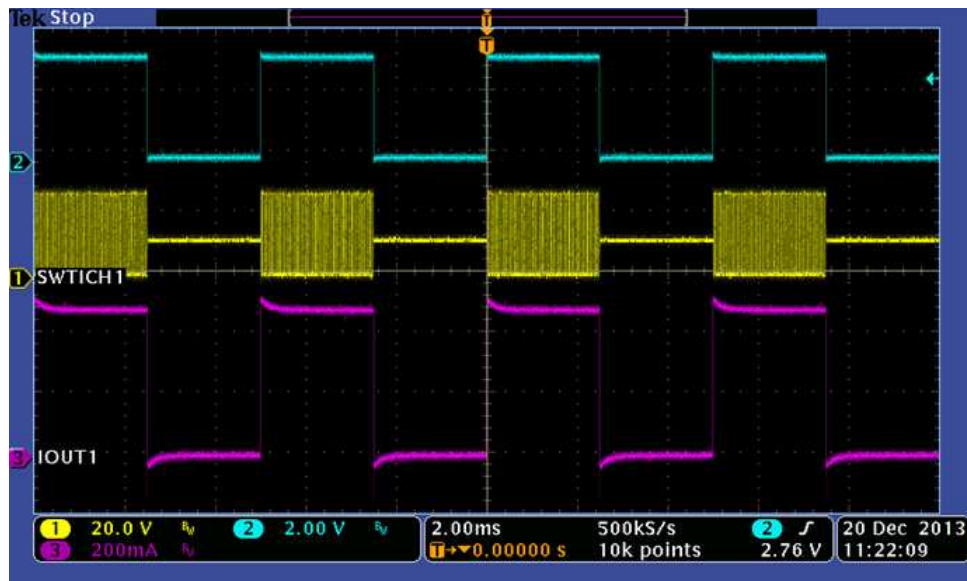

Figure 7. PWM Dimming,  $f_{PWM} = 200\text{ Hz}$ , Duty Cycle = 50%

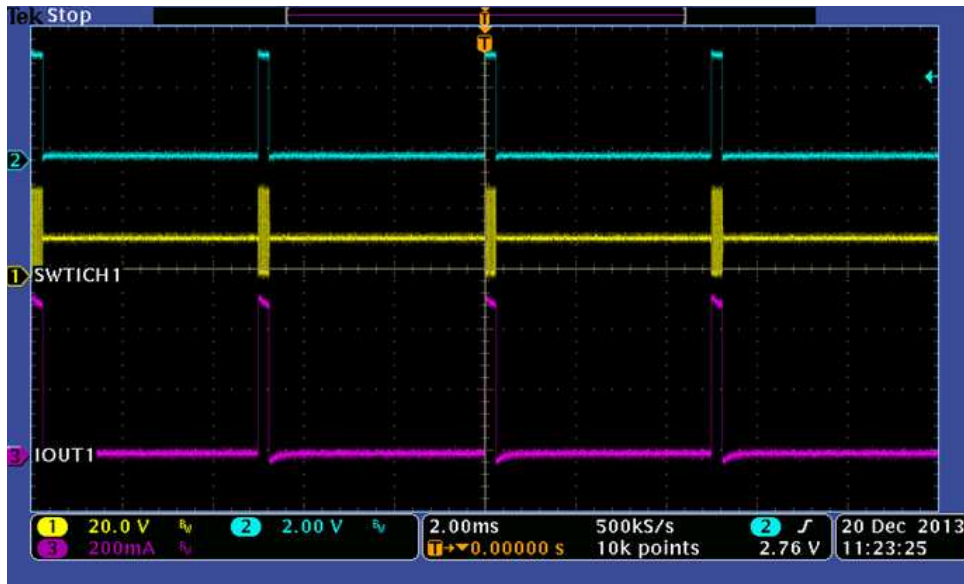

Figure 8. PWM Dimming,  $f_{PWM} = 200 \text{ Hz}$ , Duty Cycle = 5%

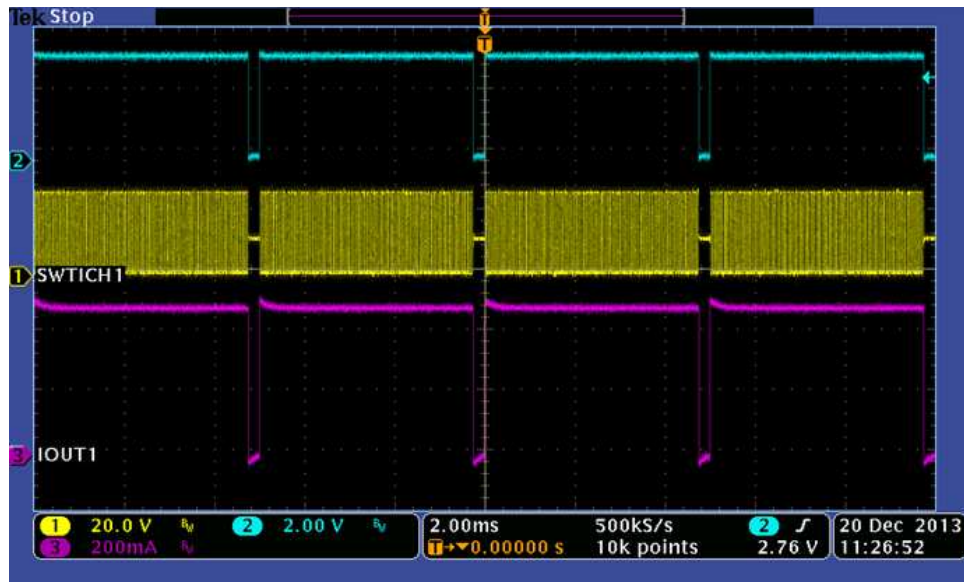

Figure 9. PWM Dimming,  $f_{PWM} = 200 \text{ Hz}$ , Duty Cycle = 95%

### 4.5 Start-Up and Shut-Down Response

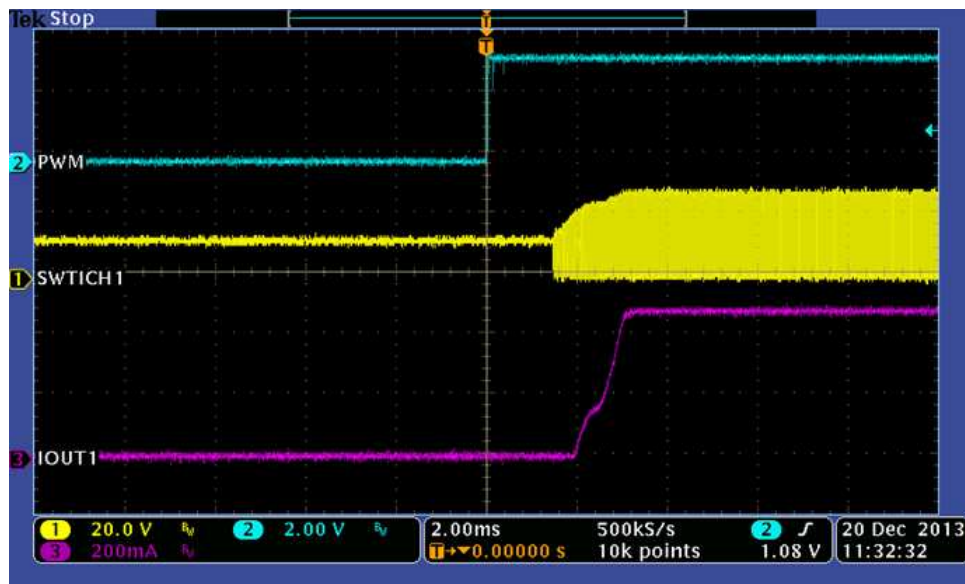

Figure 10. Start-Up Waveform

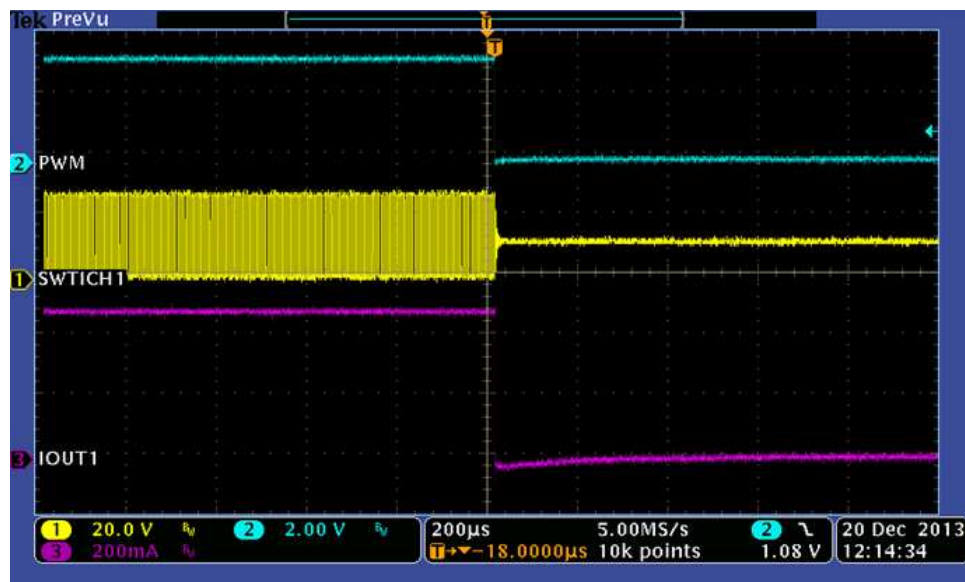

Figure 11. Shut-Down Waveform

#### 4.6 Thermal Performance

Figure 12 and Figure 13 show the steady state thermal performance of the EVM under the following conditions: Load of 10 LEDs per channel, both channels working,  $I_{(LED)} = 500\text{ mA}$ ,  $V_{(VIN)} = 12\text{ VDC}$ .

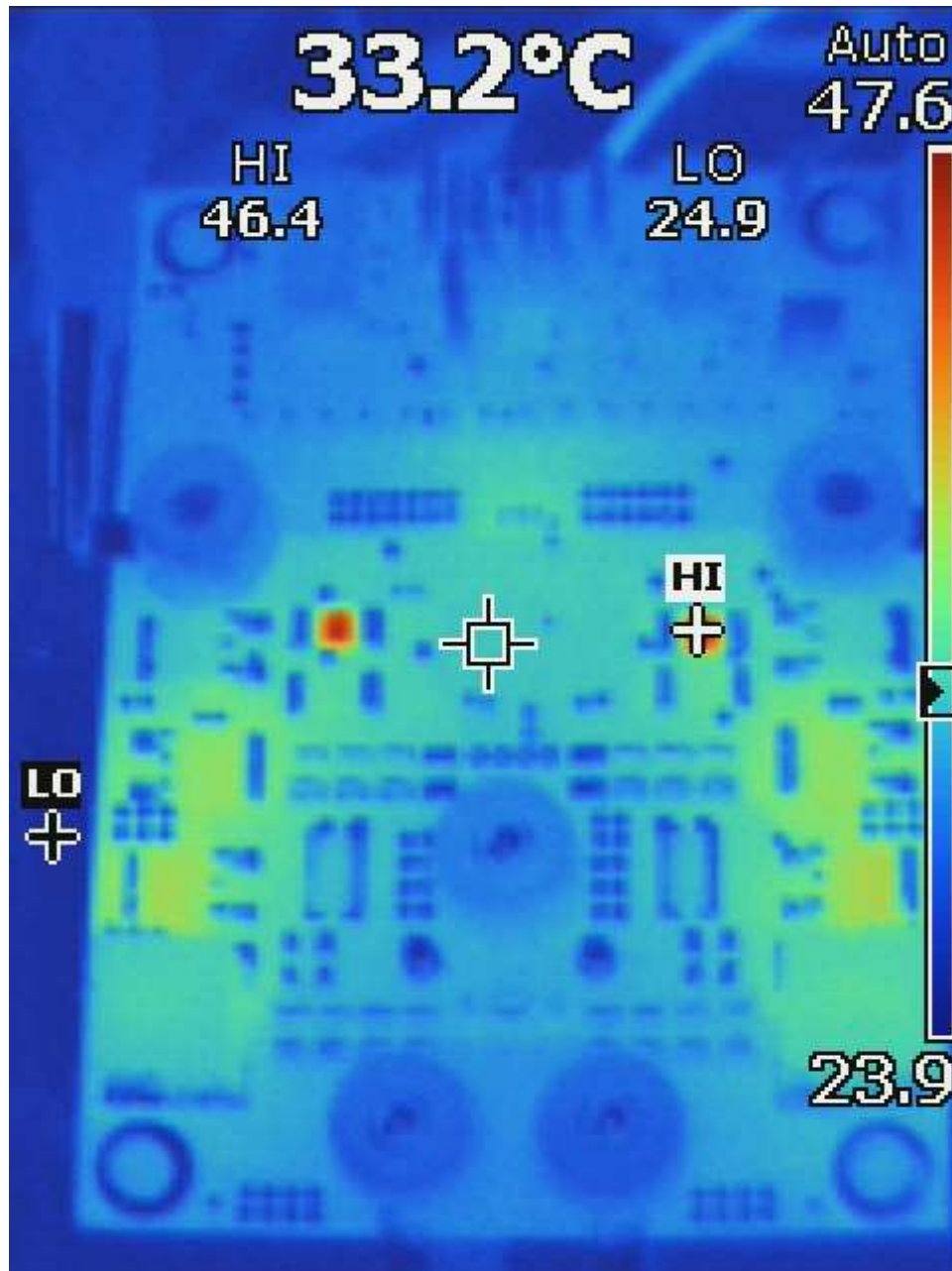

Figure 12. Top Thermal Performance

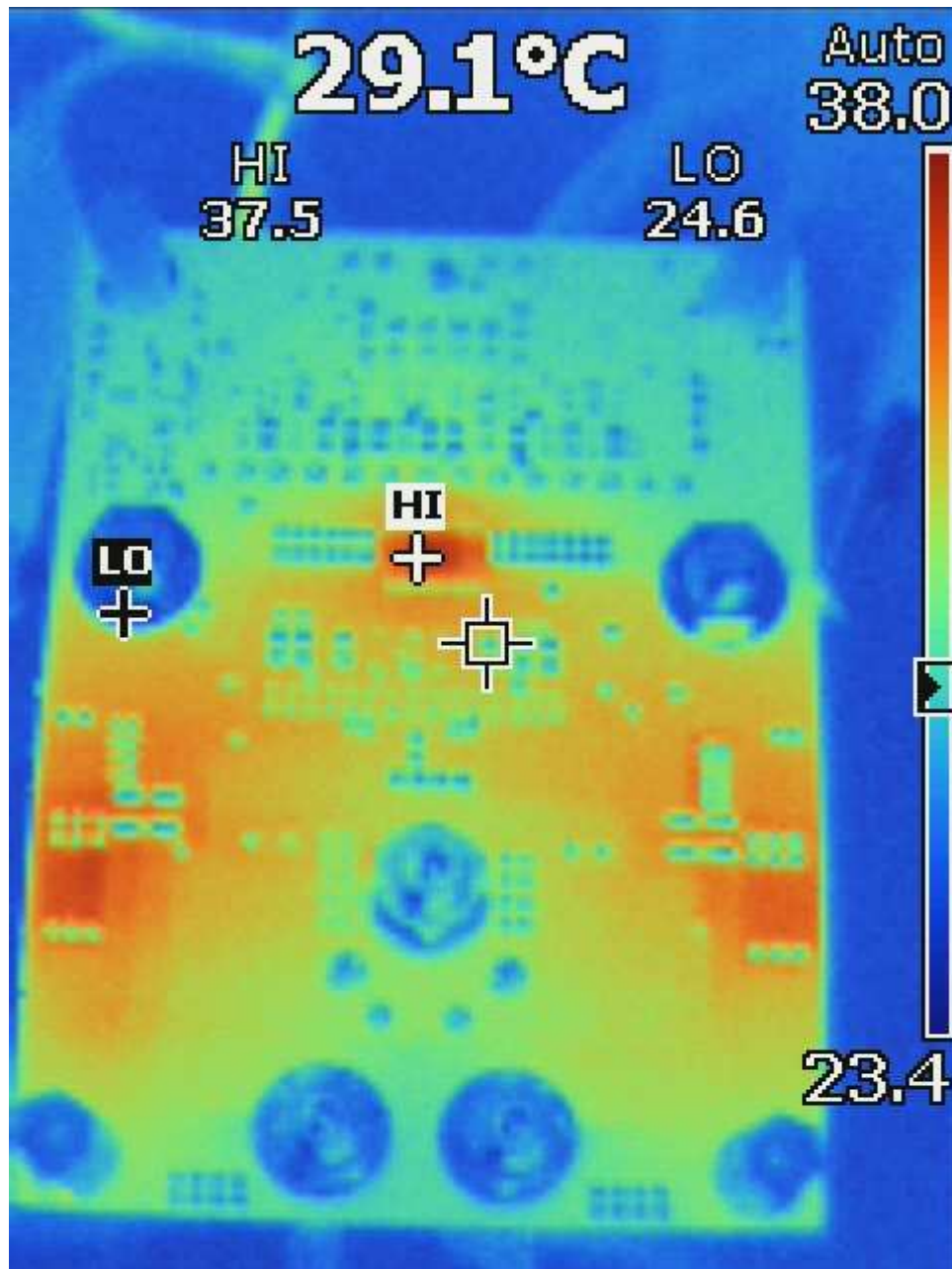

Figure 13. Bottom Thermal Performance

5 TPS92602EVM PCB Layout

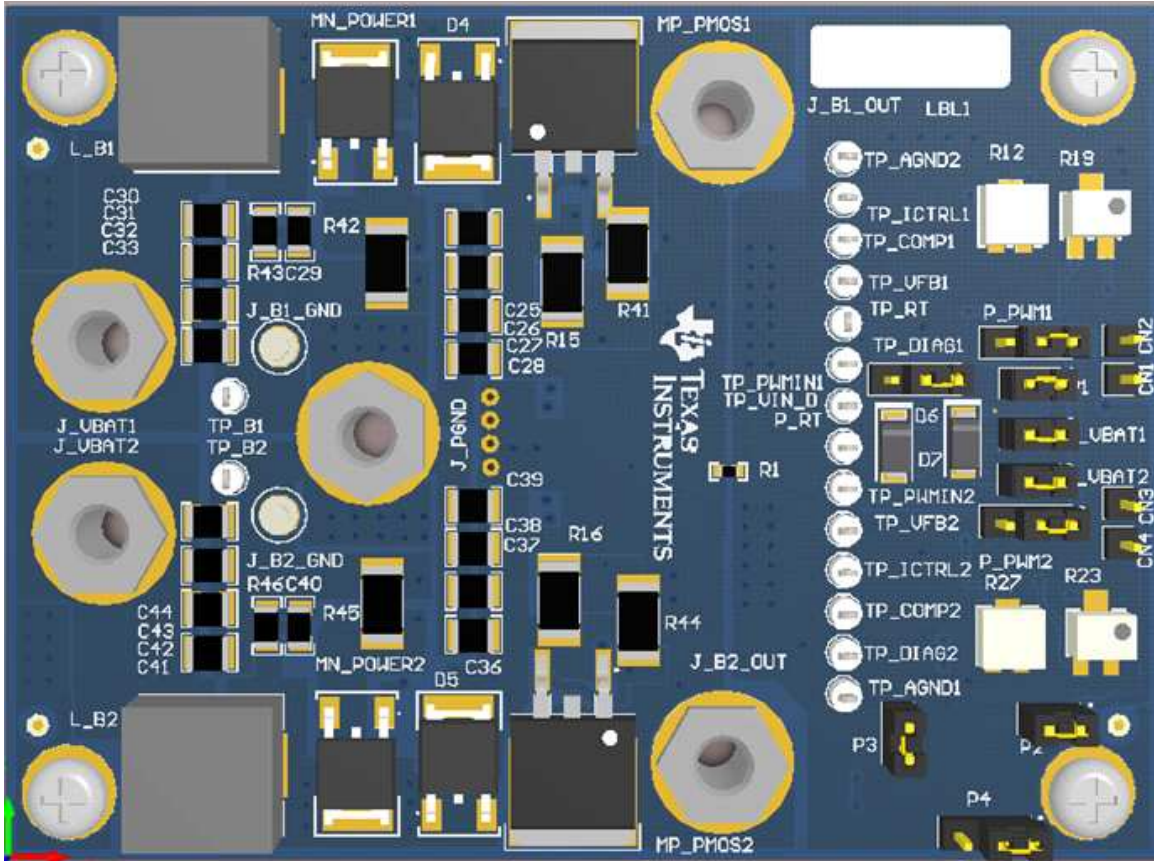

Figure 14. 3D Board View

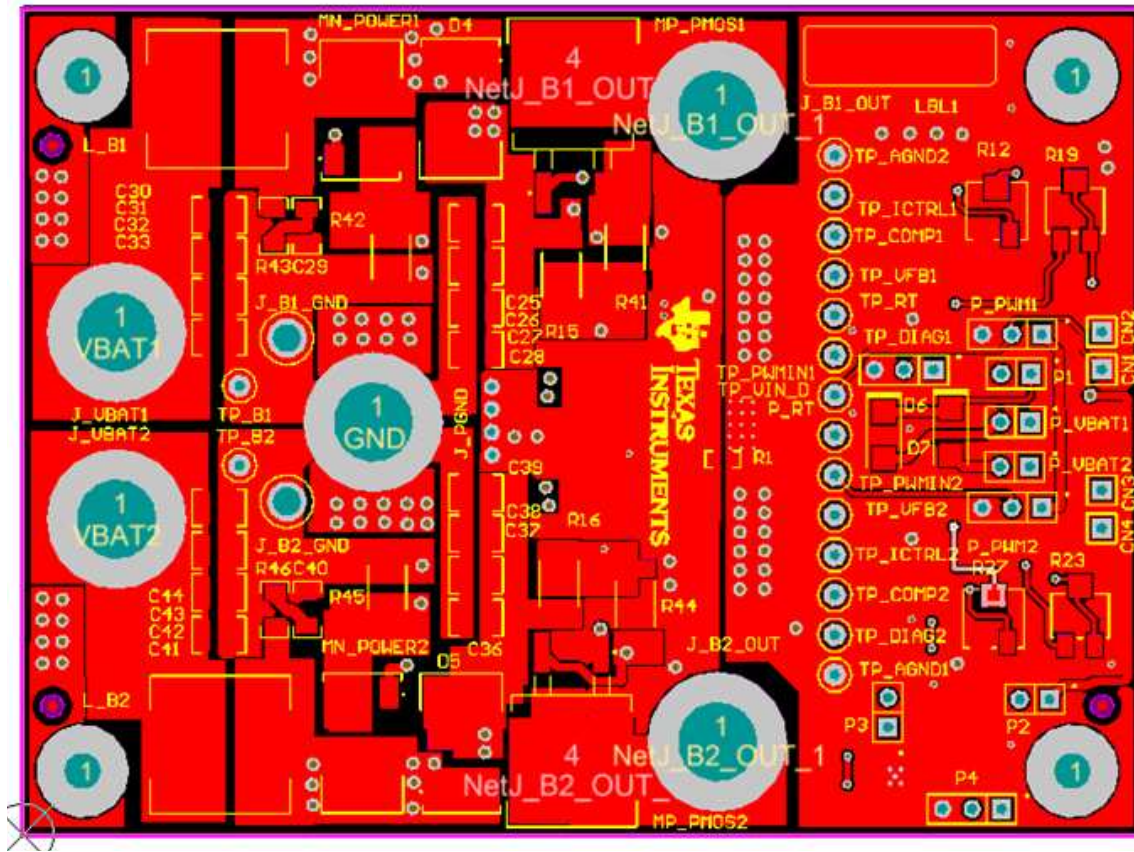

Figure 15. PCB Top Layer

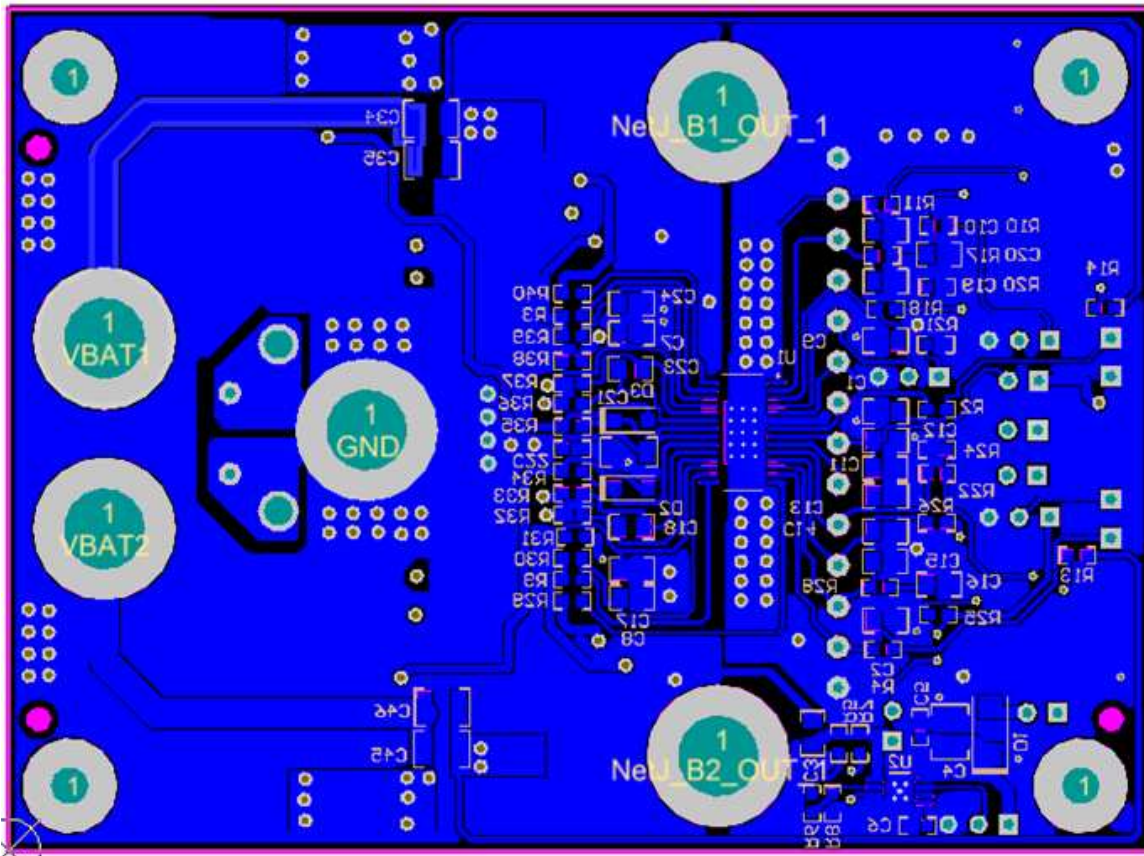

Figure 16. PCB Bottom Layer

**6 Bill of Materials**
**Table 2. Bill of Materials**

Designator	Description	RoHS	Manufacturer	Part Number	Quantity
!PCB1	Printed circuit board	O	Any	XX####	1
C1, C2, C7, C8, C9, C10, C12, C13, C14, C17, C18, C23, C24	NC	Y	AVX	NC	0
C3	Capacitor, ceramic, 4.7- $\mu$ F, 10-V, $\pm$ 10%, X5R, 0805	Y	AVX	0805ZD475KAT2A	1
C4, C30, C31, C32, C33, C34, C35, C41, C42, C43, C44, C45, C46	Capacitor, ceramic, 3.3- $\mu$ F, 50-V, $\pm$ 20%, X7R, 1210	Y	TDK	C3225X7R1H335M	13
C5	Capacitor, ceramic, 0.1- $\mu$ F, 50-V, $\pm$ 10%, X7R, 0603	Y	MuRata	GRM188R71H104KA93D	1
C6	Capacitor, ceramic, 1000-pF, 50-V, $\pm$ 10%, C0G/NP0, 0603	Y	AVX	06035A102KAT2A	1
C11	Capacitor, ceramic, 0.1- $\mu$ F, 50-V, $\pm$ 10%, X7R, 0805	Y	AVX	08055C104KAT2A	1
C15, C19	Capacitor, ceramic, 270-pF, 50-V, $\pm$ 5%, C0G/NP0, 0805	Y	Kemet	C0805C271J5GACTU	2
C16, C20	Capacitor, ceramic, 0.22- $\mu$ F, 25-V, $\pm$ 5%, X7R, 0805	Y	AVX	08053C224JAT2A	22
C21	Capacitor, ceramic, 10- $\mu$ F, 16-V, $\pm$ 20%, X5R, 1206	Y	TDK	C3216X5R1C106M	1
C22	Capacitor, ceramic, 0.1- $\mu$ F, 16-V, $\pm$ 5%, X7R, 0603	Y	AVX	0603YC104JAT2A	1
C25, C26, C27, C28, C36, C37, C38, C39	Capacitor, ceramic, 2.2- $\mu$ F, 100-V, $\pm$ 10%, X7R, 1210	Y	Taiyo Yuden	HMK325B7225KN-T	8
C29, C40	Capacitor, ceramic, 0.01- $\mu$ F, 50-V, $\pm$ 5%, C0G/NP0, 1206	Y	TDK	C3216C0G1H103J	2
CN1, CN2, CN3, CN4	Header, TH, 100-mil (2.54-mm), 1-pos, gold plated, 230 mil (5.84 mm) above insulator	Y	Samtec, Inc.	TSW-101-07-G-S	4
D1, D6, D7	Diode, Schottky, 50-V, 1-A, SMA	Y	Diodes Inc.	B150-13-F	3
D2, D3	Diode, Schottky, 60-V, 1-A, SOD-123F	Y	NXP Semiconductor	PMEG6010CEH,115	2
D4, D5	Diode, Schottky, 100-V, 12-A, DPAK	Y	Vishay-Semiconductor	12CWQ10FNPBF	2
FID1, FID2, FID3	Fiducial mark. There is nothing to buy or mount.		N/A	N/a	3
H1, H2, H5, H6	Standoff, hex, 0.5 inch (12.7 mm) L, No, 4-40 nylon	Y	Keystone	1902C	4
H3, H4, H7, H8	Machine screw, round, No. 4-40 $\times$ 1/4 inch (6.35 mm), nylon, Philips panhead	Y	B&F Fastener Supply	NY PMS 440 0025 PH	4
J_B1_GND, J_B2_GND	Terminal, turret, TH, double	Y	Keystone	1502-2	2
J_B1_OUT, J_B2_OUT, J_PGND, J_VBAT1, J_VBAT2	Standard banana jack, uninsulated, 15-A	Y	Emerson Network Power	108-0740-001	5
LBL1	Thermal transfer printable labels, 0.65 inch (16.5 mm) W $\times$ 0.2 inch (5.08 mm) H, 10,000 per roll	Y	Brady	THT-14-423-10	1
L_B1, L_B2	Inductor, shielded drum core, ferrite, 10- $\mu$ H, 9-A, 0.0144- $\Omega$ , SMD	Y	Würth Elektronik eiSos	7443321000	2
MN_POWER1, MN_POWER2	MOSFET, N-ch, 100-V, 40-A, DPAK	Y	Vishay-Siliconix	SUD40N10-25	2

**Table 2. Bill of Materials (continued)**

Designator	Description	RoHS	Manufacturer	Part Number	Quantity
MP_PMOS1, MP_PMOS2	MOSFET, P-ch, -100-V, -17.2-A, DDPAK	Y	Vishay-Siliconix	SUM90P10-19L	2
P1, P2, P3, P_VBAT1, P_VBAT2	Header, TH, 100-mil (2.54-mm), 2x1, gold plated, 230 mil (8.84 mm) above insulator	Y	Samtec, Inc.	TSW-102-07-G-S	5
P4, P_PWM1, P_PWM2, P_RT	Header, TH, 100-mil (2.54-mm), 3x1, gold plated, 230 mil (8.84 mm) above insulator	Y	Samtec, Inc.	TSW-103-07-G-S	4
R1, R2, R4, R9, R11, R18, R22, R26, R29, R30, R31, R32, R33, R36, R37, R38, R40	Resistor, 0-Ω, 5%, 0.1-W, 0603	Y	Rohm	MCR03EZPJ000	17
R3, R13, R14, R39	Resistor, 0-Ω, 5%, 0.1-W, 0603	Y	Panasonic	ERJ-3GEY0R00V	4
R5	Resistor, 0 Ω, 5%, 0.1W, 0603	Y	Vishay-Dale	CRCW06030000Z0EA	1
R6	Resistor, 1.87-kΩ, 1%, 0.1-W, 0603	Y	Vishay-Dale	CRCW06031K87FKEA	1
R7	Resistor, 10 kΩ, 5%, 0.1-W, 0603	Y	Vishay-Dale	CRCW060310K0JNEA	1
R8	Resistor, 8.2 kΩ, 5%, 0.1 W, 0603	Y	Vishay-Dale	CRCW06038K20JNEA	1
R10, R25	Resistor, 10 kΩ, 1%, 0.1 W, 0603	Y	Vishay-Dale	CRCW060310K0FKEA	2
R12, R27	Trimmer, 20-kΩ, 0.25-W, SMD	Y	Bourns	3224J-1-203 E	2
R15, R16	Resistor, 0.003-Ω, 1%, 1-W, 2512	Y	CTS Resistor	73M1R003F	2
R17, R28	Resistor, 510-Ω, 1%, 0.1-W, 0603	Y	Yageo America	RC0603FR-07510RL	2
R19, R23	Trimmer, 1-MΩ, 0.25-W SMD	Y	Bourns	3224X-1-105E	2
R20, R24	Resistor, 30-k Ω, 0.1%, 0.1-W, 0603	Y	Susumu Co Ltd	RG1608P-303-B-T5	2
R21	Resistor, 20-k Ω, 1%, 0.1-W, 0603	Y	Vishay-Dale	CRCW060320K0FKEA	1
R34, R35	Resistor, 10-Ω, 5%, 0.1-W, 0603	Y	Vishay-Dale	CRCW060310R0JNEA	2
R41, R44	Resistor, 0.3-Ω, 1%, 2-W, 2512	Y	Stackpole Electronics Inc	CSRN2512FKR300	2
R42, R45	Resistor, 0.015-Ω, 1%, 2-W, 2512	Y	Stackpole Electronics Inc	CSRN2512FK15L0	2
R43, R46	Resistor, 51-Ω, 1%, 0.25-W, 1206	Y	Yageo America	RC1206FR-0751RL	2
SH-P1, SH-P2, SH-P3, SH-P4, SH-PWM1, SH-PWM2, SH-RT, SH-VBAT1, SH-VBAT2	Shunt, 100-mil (2.54-mm), gold plated, black	Y	3M	969102-0000-DA	9
TP_AGND1, TP_AGND2, TP_B1, TP_B2, TP_COMP1, TP_COMP2, TP_DIAG1, TP_DIAG2, TP_ICTRL1, TP_ICTRL2, TP_PWMIN1, TP_PWMIN2, TP_RT, TP_VFB1, TP_VFB2, TP_VIN_D	Test point, TH, miniature, white	Y	Keystone	5002	16
U1	Automotive headlight LED driver, 2-channel, PWP0028F	Y	Texas Instruments	TPS92602QPWPRQ1	1
U2	High-voltage ultralow-Iq low-dropout regulator, DGN0008D	Y	Texas Instruments	TPS7A6650QDGNRQ1	1

## IMPORTANT NOTICE

Texas Instruments Incorporated and its subsidiaries (TI) reserve the right to make corrections, enhancements, improvements and other changes to its semiconductor products and services per JESD46, latest issue, and to discontinue any product or service per JESD48, latest issue. Buyers should obtain the latest relevant information before placing orders and should verify that such information is current and complete. All semiconductor products (also referred to herein as "components") are sold subject to TI's terms and conditions of sale supplied at the time of order acknowledgment.

TI warrants performance of its components to the specifications applicable at the time of sale, in accordance with the warranty in TI's terms and conditions of sale of semiconductor products. Testing and other quality control techniques are used to the extent TI deems necessary to support this warranty. Except where mandated by applicable law, testing of all parameters of each component is not necessarily performed.

TI assumes no liability for applications assistance or the design of Buyers' products. Buyers are responsible for their products and applications using TI components. To minimize the risks associated with Buyers' products and applications, Buyers should provide adequate design and operating safeguards.

TI does not warrant or represent that any license, either express or implied, is granted under any patent right, copyright, mask work right, or other intellectual property right relating to any combination, machine, or process in which TI components or services are used. Information published by TI regarding third-party products or services does not constitute a license to use such products or services or a warranty or endorsement thereof. Use of such information may require a license from a third party under the patents or other intellectual property of the third party, or a license from TI under the patents or other intellectual property of TI.

Reproduction of significant portions of TI information in TI data books or data sheets is permissible only if reproduction is without alteration and is accompanied by all associated warranties, conditions, limitations, and notices. TI is not responsible or liable for such altered documentation. Information of third parties may be subject to additional restrictions.

Resale of TI components or services with statements different from or beyond the parameters stated by TI for that component or service voids all express and any implied warranties for the associated TI component or service and is an unfair and deceptive business practice. TI is not responsible or liable for any such statements.

Buyer acknowledges and agrees that it is solely responsible for compliance with all legal, regulatory and safety-related requirements concerning its products, and any use of TI components in its applications, notwithstanding any applications-related information or support that may be provided by TI. Buyer represents and agrees that it has all the necessary expertise to create and implement safeguards which anticipate dangerous consequences of failures, monitor failures and their consequences, lessen the likelihood of failures that might cause harm and take appropriate remedial actions. Buyer will fully indemnify TI and its representatives against any damages arising out of the use of any TI components in safety-critical applications.

In some cases, TI components may be promoted specifically to facilitate safety-related applications. With such components, TI's goal is to help enable customers to design and create their own end-product solutions that meet applicable functional safety standards and requirements. Nonetheless, such components are subject to these terms.

No TI components are authorized for use in FDA Class III (or similar life-critical medical equipment) unless authorized officers of the parties have executed a special agreement specifically governing such use.

Only those TI components which TI has specifically designated as military grade or "enhanced plastic" are designed and intended for use in military/aerospace applications or environments. Buyer acknowledges and agrees that any military or aerospace use of TI components which have **not** been so designated is solely at the Buyer's risk, and that Buyer is solely responsible for compliance with all legal and regulatory requirements in connection with such use.

TI has specifically designated certain components as meeting ISO/TS16949 requirements, mainly for automotive use. In any case of use of non-designated products, TI will not be responsible for any failure to meet ISO/TS16949.

### Products

Audio	<a href="http://www.ti.com/audio">www.ti.com/audio</a>
Amplifiers	<a href="http://amplifier.ti.com">amplifier.ti.com</a>
Data Converters	<a href="http://dataconverter.ti.com">dataconverter.ti.com</a>
DLP® Products	<a href="http://www.dlp.com">www.dlp.com</a>
DSP	<a href="http://dsp.ti.com">dsp.ti.com</a>
Clocks and Timers	<a href="http://www.ti.com/clocks">www.ti.com/clocks</a>
Interface	<a href="http://interface.ti.com">interface.ti.com</a>
Logic	<a href="http://logic.ti.com">logic.ti.com</a>
Power Mgmt	<a href="http://power.ti.com">power.ti.com</a>
Microcontrollers	<a href="http://microcontroller.ti.com">microcontroller.ti.com</a>
RFID	<a href="http://www.ti-rfid.com">www.ti-rfid.com</a>
OMAP Applications Processors	<a href="http://www.ti.com/omap">www.ti.com/omap</a>
Wireless Connectivity	<a href="http://www.ti.com/wirelessconnectivity">www.ti.com/wirelessconnectivity</a>

### Applications

Automotive and Transportation	<a href="http://www.ti.com/automotive">www.ti.com/automotive</a>
Communications and Telecom	<a href="http://www.ti.com/communications">www.ti.com/communications</a>
Computers and Peripherals	<a href="http://www.ti.com/computers">www.ti.com/computers</a>
Consumer Electronics	<a href="http://www.ti.com/consumer-apps">www.ti.com/consumer-apps</a>
Energy and Lighting	<a href="http://www.ti.com/energy">www.ti.com/energy</a>
Industrial	<a href="http://www.ti.com/industrial">www.ti.com/industrial</a>
Medical	<a href="http://www.ti.com/medical">www.ti.com/medical</a>
Security	<a href="http://www.ti.com/security">www.ti.com/security</a>
Space, Avionics and Defense	<a href="http://www.ti.com/space-avionics-defense">www.ti.com/space-avionics-defense</a>
Video and Imaging	<a href="http://www.ti.com/video">www.ti.com/video</a>

### TI E2E Community

[e2e.ti.com](http://e2e.ti.com)

## Looking for pricing, stock, or lifecycle information?

Click below to explore more details on WIN SOURCE:

 [View TPS61197EVM](#) on WIN SOURCE

 [Texas Instruments](#) Information

## Optimize Your Supply Chain with WIN SOURCE Solutions

-  Global Sourcing Solution
-  Obsolete Management
-  Cost Control Management
-  Shortage Management
-  Alternative Solution
-  Excess Inventory Management