



THE DATASHEET OF
2708096



PSI-MOS-RS422/FO...

Fiber optic converter for
RS-422/RS-485 4-wire/INTERBUS



INTERFACE

Data sheet
101974_en_04

© PHOENIX CONTACT - 2010-01-28

1 Description

PSI-MOS-RS422/FO... devices convert RS-422/RS-485 4-wire and INTERBUS interfaces to fiber optics. A transparent protocol is used to convert all data rates up to a maximum of 2000 kbps. The integrated optical diagnostics enable fiber optic paths to be monitored continuously during installation and even during operation. The floating switch contact is activated when the signal level on the fiber optic paths reaches a critical level. This early alarm generation enables critical system states to be detected before they result in failure.

The main advantage of this system is the electrically isolated connection of devices, which prevents the negative effects of voltage equalization currents and electromagnetic interference on the data cables. This increases the overall availability of the system, and improves flexibility in terms of the design of the network topology in a linear or star structure.

PSI-MOS RS422/FO 660 ... devices are networked using polymer fiber cable for distances up to 100 m and HCS fiber cable for distances up to 800 m.

They are connected via F-SMA fast connection connectors, which can be assembled locally within a few minutes.

PSI-MOS RS422/FO 850 ... devices are available for longer paths and can be used for distances up to 2800 m using HCS fiber and B-FOC fast connection technology and up to 4800 m using multi-mode glass fiber.

The PSI-MOS system can be used with input voltages from 18 V DC to 32 V DC and in a temperature range from -20°C to +60°C.



If you have any technical problems, which you cannot resolve with the aid of this documentation, please contact us during the usual office hours at:

Phone: +49 - 52 35 - 31 98 90

Fax: +49 - 52 35 - 33 09 99

E-mail: interface-service@phoenixcontact.com



Make sure you always use the latest documentation.

It can be downloaded at www.phoenixcontact.net/catalog.



This data sheet is valid for all products listed on the following page:

Table of contents

1	Description.....	1
2	Ordering data.....	3
3	Technical data	4
4	Safety regulations and installation notes.....	7
	4.1 Installation and operation	7
	4.2 Installation in zone 2.....	7
5	Supported network structures	8
	5.1 Point-to-point connections.....	8
	5.2 Linear structures.....	8
	5.3 Star structures	8
	5.4 Use in INTERBUS networks	9
6	Function elements	9
7	Definition of fiber optic diagnostics	10
	7.1 Point-to-point connections.....	10
	7.2 Star structures	10
8	Configuration	11
	8.1 Operation in a point-to-point connection (DIP 1).....	11
	8.2 Operation in a linear structure (DIP 1)	11
	8.3 Operation in a star structure (DIP 1)	12
	8.4 Operation in an INTERBUS system.....	12
	8.5 Connection to fiber optic interfaces from third-party suppliers (DIP 2)	12
	8.6 Activating the redundancy function (DIP 3).....	12
	8.7 Disabling the second fiber optic port (DIP 4)	12
9	Connection notes	13
	9.1 Combined assembly with a system power supply unit (modular star coupler)	13
	9.2 Assembly as an individual device in the control cabinet (stand-alone)	14
	9.3 Assembly in potentially explosive areas	14
	9.4 Removal	14
10	Cabling notes.....	15
	10.1 Connecting the supply voltage	15
	10.2 Connecting the data cables/bus termination.....	15
	10.3 Wiring the switch contact.....	17
	10.4 Connecting the fiber optic cables	18

2 Ordering data

Fiber optic converters

Description	Type	Order No.	Pcs./Pkt.
Termination device with integrated optical diagnostics for converting the RS-422 interface to one fiber optic cable			
660 nm	PSI-MOS-RS422/FO 660 E	2708342	1
850 nm	PSI-MOS-RS422/FO 850 E	2708355	1
T-coupler with integrated optical diagnostics for converting the RS-422 interface to two fiber optic cables			
660 nm	PSI-MOS-RS422/FO 660 T	2708384	1
850 nm	PSI-MOS-RS422/FO 850 T	2708397	1

Accessories

Description	Type	Order No.	Pcs./Pkt.
System power supply unit for supplying a modular star coupler topology	MINI-SYS-PS 100-240AC/24DC/1.5	2866983	1
System power supply unit for supplying a modular star coupler topology, for potentially explosive areas	MINI-PS-100-240AC/24DC/1.5/EX	2866653	1
End clamps	CLIPFIX 35	3022218	50
DIN rail connector, power supply and data (2 per device)	ME 17,5 TBUS1,5/5-ST-3,81GN	2709561	10
DIN rail connector, power supply only (2 per device)	ME 17,5 TBUS1,5/PP000-3,81BK	2890014	10
Polymer fiber connectors (4 connectors in the set)	PSM-SET-FSMA/4-KT	2799720	1
Polishing set for polymer fiber connectors (required to assemble polymer fiber connectors)	PSM-SET-FSMA-POLISH	2799348	1
Fiber optic polymer fiber cable for indoor installation	PSM-LWL-KDHEAVY	2744319	1
F-SMA HCS fiber connectors (4 connectors in the set)	PSM-SET-FSMA/4-HCS	2799487	1
B-FOC (ST®) HCS fiber connectors (4 connectors in the set)	PSM-SET-B-FOC/4-HCS	2708481	1
Tool set for HCS connectors (F-SMA) (required for HCS connector assembly)	PSM-HCS-KONFTOOL	2799526	1
Tool set for HCS connectors (B-FOC (ST®)) (required for HCS connector assembly)	PSM-HCS-KONFTOOL/B-FOC	2708465	1
Fiber optic HCS cable for indoor installation	PSM-LWL-HCS RUGGED-200/230	2799885	1
Fiber optic HCS cable for outdoor installation	PSM-LWL-HCSO-200/230	2799445	1
Fiber optic glass fiber cable for indoor installation	PSM-LWL-GDM-RUGGED-50/125	2799322	1
Fiber optic glass fiber cable for outdoor installation	PSM-LWL-GDO-50/125	2799432	1
Measuring device for fiber optic power measurement	PSM-FO-POWERMETER	2799539	1

Other fiber optic converters in the PSI-MOS system

The PSI-MOS-RS422/FO 1300 E is networked for distances up to 27 km using multi-mode glass fiber cable and up to 45 km using single mode glass fiber cable.

Other fiber optic converters

Description	Type	Order No.	Pcs./Pkt.
Fiber optic converter with integrated optical diagnostics, alarm contact, for RS-422/RS-485 4-wire and INTERBUS interfaces, termination device with one fiber optic interface (SC duplex), 1300 nm, for multi-mode and single mode glass fiber cable	PSI-MOS-RS422/FO 1300 E	2708575	1

3 Technical data

Interfaces			
Power supply	24 V DC (18 V DC ... 32 V DC)		
Nominal current consumption	130 mA, maximum		
Ready-to-operate indicator	"VCC" LED (green)		
Maximum star coupler expansion	10		
Serial RS-422/RS-485 4-wire interface			
	According to ITU-T V.11, EIA/TIA-422, DIN 66348-1		
Operating mode	Full duplex		
Data format/encoding	UART (11 bits, NRZ)		
Termination resistors	Receiver 100 Ω, pull-up/pull-down 220 Ω		
Transmission speed (automatic detection)	0 kbps ... 2000 kbps (NRZ)		
Transmission length	1000 m, maximum (depending on the transmission speed)		
Connection	COMBICON connector		
Optical interface			
Transmission protocol	Transparent protocol to RS-422 interface		
Connection method	F-SMA	B-FOC (ST®)	
Wavelength	660 nm	850 nm	
Minimum transmission power (fiber type)	-4.6 dBm (980/1000 μm) -16.6 dBm (200/230 μm)	-4.6 dBm (200/230 μm) -17.6 dBm (50/125 μm) -13.6 dBm (62.5/125 μm)	
Receiver sensitivity			
Minimum	-31.2 dBm	-33.2 dBm	
Minimum transmission length including 3 dB system reserve	100 m with F-P 980/1000; 230 dB/km 800 m with F-K 200/230; 10 dB/km with quick mounting connectors	4200 m with F-G 50/125; 2.5 dB/km 4200 m with F-G 62.5/125; 3.0 dB/km 2800 m with F-K 200/230; 8.0 dB/km	
General data			
Bit distortion input	±35%, maximum		
Bit distortion output	< 6.25%		
Bit delay	< 1 bit		
Electrical isolation	RS-422/power supply		
Test voltage	1.5 kV _{rms} , 50 Hz, 1 min.		
Alarm output	60 V DC/42 V AC, 1 A, maximum		
Status and diagnostic indicators	Power supply (VCC), transmit/receive data RS-422, fiber optic bar graph (FO SIGNAL), fiber optic error (FO ERR)		
Housing material	PA V0, green		
Ambient temperature			
Operation	-20°C ... +60°C		
Storage/transport	-40°C ... +85°C		
Humidity	30% ... 95%, no condensation		
Dimensions (W x H x D)	35 mm x 105 mm x 99 mm		
Degree of protection	IP20		
Weight	200 g, approximately		
MTBF according to Telcordia standard	Termination devices (E)		T-couplers (T)
	660 nm	850 nm	660 nm 850 nm
Ambient temperature 25°C	493 years	320 years	284 years 178 years
Ambient temperature 40°C	92 years	48 years	52 years 26 years
Vibration resistance	5g according to IEC 60068-2-6, 2.5 h each in x, y, and z direction, criterion A		
Shock resistance	15g according to IEC 60068-2-27 with 11 ms pulse length, criterion C		
Free fall	1 m without packaging according to IEC 60950		
Air and creepage distances	DIN EN 60664-1/VDE 0110-1, DIN EN 50178, DIN EN 60950		

Tests/approvals

CE



UL/CUL 1604 Ex listed

PROCESS CONTROL EQUIPMENT FOR HAZARDOUS
LOCATIONS
31ZN

Ex

Fiber optic interface
DeviceII (2) GD [EX op is] IIC (PTB 06 ATEX 2042 u)
II 3G Ex nAC IIC T4 X**Conformance with EMC Directive 2004/108/EC and Low Voltage Directive 2006/95/EC****Noise immunity test according to EN 61000-6-2¹**

Electrostatic discharge (ESD)	EN 61000-4-2	Criterion B ²	
Air discharge			8 kV
Contact discharge			6 kV
Electromagnetic HF field	EN 61000-4-3	Criterion A ³	
Amplitude modulation			10 V/m
Fast transients (burst)	EN 61000-4-4	Criterion B ²	
Signal			2 kV/5 kHz
Power supply			2 kV/5 kHz
Surge current load (surge)	EN 61000-4-5	Criterion B ²	
Signal			1 kV/42 Ω
Power supply			0.5 kV/2 Ω
Conducted interference	EN 61000-4-6	Criterion A ³	10 V

Noise emission test according to EN 61000-6-4

Noise emission of housing	EN 55011 ⁴	Class A ⁵	
---------------------------	-----------------------	----------------------	--

¹ EN 61000 corresponds to IEC 61000² Criterion B: Temporary adverse effects on the operating behavior, which the device corrects automatically.³ Criterion A: Normal operating behavior within the specified limits.⁴ EN 55011 corresponds to CISPR11⁵ Class A: Industrial application, without special installation measures.

Block diagram

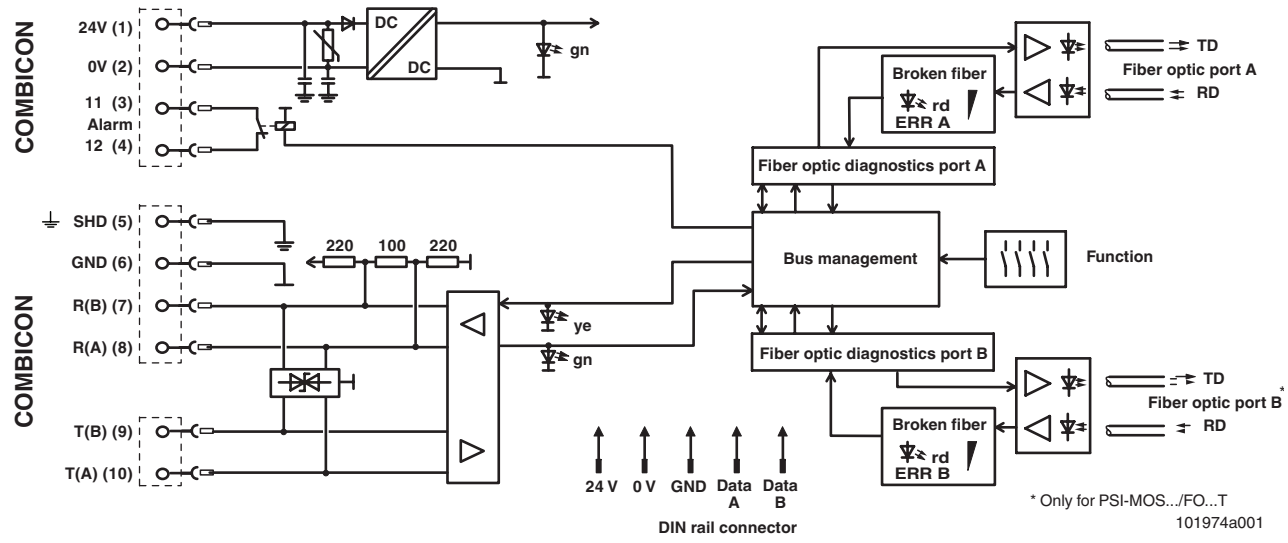

Figure 1 Block diagram

Housing dimensions

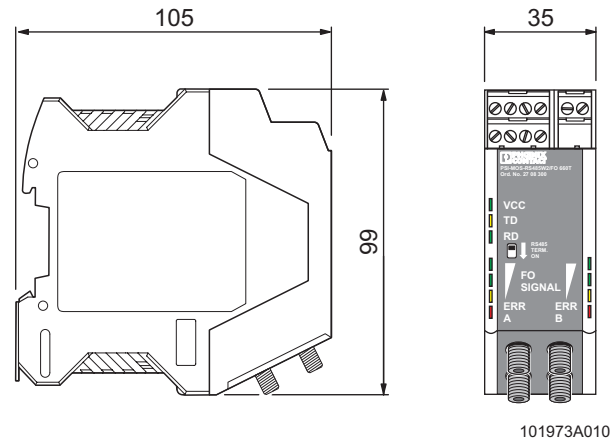

Figure 2 Housing dimensions (in mm)

4 Safety regulations and installation notes

4.1 Installation and operation

Follow the installation instructions.



NOTE: Installation, operation, and maintenance may only be carried out by qualified specialist personnel.

When installing and operating the device, the applicable safety directives (including national safety directives), accident prevention regulations, as well as general technical regulations, must be observed.



NOTE: The device must not be opened or modified apart from the configuration of the DIP switches.



NOTE: The switches that can be accessed may only be actuated when the power supply to the device is disconnected.

Do not repair the device yourself, replace it with an equivalent device. Repairs may only be carried out by the manufacturer.



NOTE: The IP20 degree of protection (IEC 60529/EN 60529) of the device is intended for use in a clean and dry environment. The device must not be subject to mechanical strain and/or thermal loads, which exceed the limits described.

For the safety data, please refer to the operating instructions and certificates (EC-type examination certificate, other approvals, if necessary).

4.2 Installation in zone 2



WARNING: Explosion hazard

The device is designed for installation in zone 2 potentially explosive areas.

Observe the specified conditions for use in potentially explosive areas.



WARNING: Explosion hazard

Install the device in suitable **housing with IP54 protection, minimum**, that meets the requirements of EN 60079-15.

Observe the requirements of EN 60079-14.



WARNING: Explosion hazard

Disconnect the block power supply **before**:

- Snapping it on or disconnecting it.
- Connecting or disconnecting cables.



WARNING: Explosion hazard

Only devices which are designed for operation in zone 2 potentially explosive areas and are suitable for the conditions at the installation location may be connected to the supply and signal circuits in zone 2.



WARNING: Explosion hazard

The device must be stopped and immediately removed from the Ex area if it is damaged or was subject to an impermissible load or stored incorrectly or if it malfunctions.

Installation in areas with a danger of dust explosions



WARNING: Explosion hazard

The device is **not** designed for installation in areas with a danger of dust explosions.

If dust is present, install the device in suitable, approved housing.

5 Supported network structures

The PSI-MOS-RS422/FO... system can be used to create network topologies that are ideally adapted to the relevant application. The structures are described briefly below.

5.1 Point-to-point connections

Two PSI-MOS-RS422/FO... E fiber optic termination devices can be used to easily convert a data link from copper cable to fiber optics.

If necessary, the point-to-point connection can also be designed redundantly to increase availability using PSI-MOS-RS422/FO... T T-couplers.

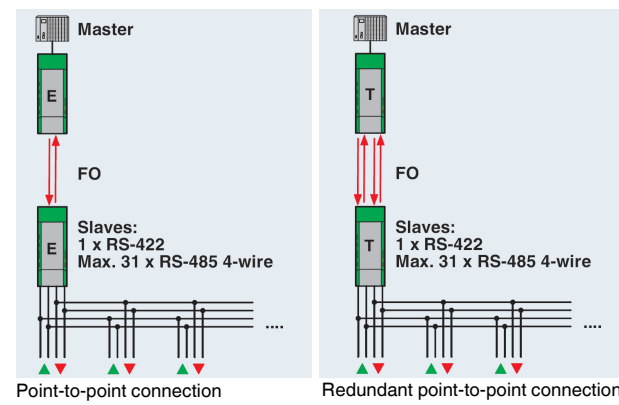

5.2 Linear structures

PSI-MOS-RS422/FO... devices can be used to network several RS-422/RS-485 4-wire devices to form a linear structure.

In this case, it must be possible to address all the termination devices via communication software.

PSI-MOS-RS422/FO... E termination devices are used at the beginning and end of the fiber optic line.

PSI-MOS-RS422/FO... T T-couplers with two fiber optic ports are used along the line.

The cascability of the fiber optic devices is limited by the data rate.

Data rate	Number of devices	Data rate	Number of devices
≤ 115.2 kbps	15	≤ 500 kbps	3
≤ 187.5 kbps	7	≤ 2000 kbps	2
≤ 375 kbps	5		

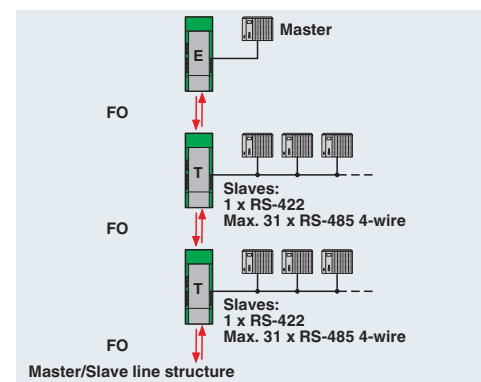

5.3 Star structures

RS-422/RS-485 4-wire devices can also be networked in a star structure. Depending on the number of star lines required, several T-couplers or termination devices are connected to an active star coupler.

Up to ten PSI-MOS-RS422/FO... devices can be connected to each star coupler. Cross-wiring for data and for the supply voltage is provided automatically by the DIN rail connector (installation accessory, see page 3).

If increased availability is required, redundant star distributors can also be created using PSI-MOS-RS422/FO... T T-couplers.

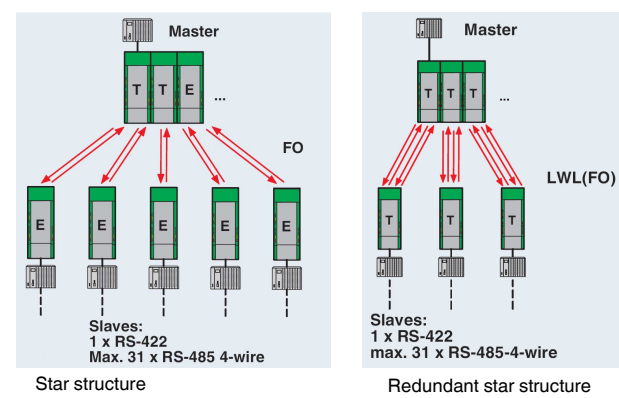

5.4 Use in INTERBUS networks

PSI-MOS-RS422/FO... converters can also be used to create INTERBUS networks with fiber optic technology. For standard INTERBUS connections, the REMOTE IN and REMOTE OUT interfaces are converted to fiber optics using one PSI-MOS-RS422/FO... E termination device each.

Redundant fiber optic connections can also be implemented for INTERBUS using PSI-MOS-RS422/FO... T T-couplers.

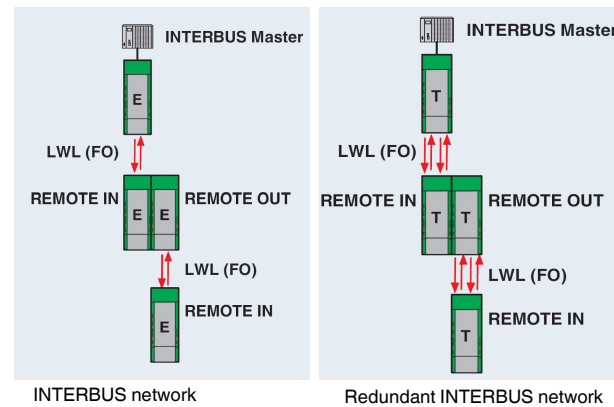

6 Function elements

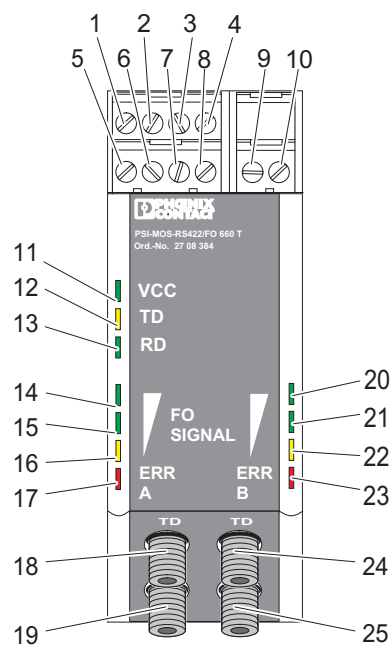

Figure 3 Function elements

- 1 24 V DC supply voltage connection
- 2 0 V DC supply voltage connection
- 3 Switch contact, connection 11
- 4 Switch contact, connection 12
- 5 SHD, shield
- 6 GND
- 7 Receive +: R(B)
- 8 Receive -: R(A)
- 9 Transmit +: T(B)

- 10 Transmit -: T(A)
- 11 "VCC" LED
- 12 "TD" LED
- 13 "RD" LED
- 14 "FO SIGNAL" LED (port A)
- 15 "FO SIGNAL" LED (port A)
- 16 "FO SIGNAL" LED (port A)
- 17 "ERR" LED (port A)
- 18 Fiber optic transmitter (port A)
- 19 Fiber optic receiver (port A)
- 20 "FO SIGNAL" LED (port B)¹
- 21 "FO SIGNAL" LED (port B)¹
- 22 "FO SIGNAL" LED (port B)¹
- 23 "ERR" LED (port B)¹
- 24 Fiber optic transmitter (port B)¹
- 25 Fiber optic receiver (port B)¹

Diagnostic and status indicators

Des.	Color	Meaning	
VCC	Green	Ready-to-operate	
TD	Yellow	Sending data at the RS-422 copper interface	
RD	Green	Receiving data at the RS-422 copper interface	
FO SIGNAL	Green	Receiving power at fiber optic port A/B (see page 10)	Very good
	Green		Good
	Yellow		Critical
ERR	Red	Insufficient, broken fiber	

¹ Only for PSI-MOS-RS422/FO... T

7 Definition of fiber optic diagnostics

The quality of the path is determined using the incoming optical power P_{opt} and displayed using the LED bar graph. DIP 2 is used to switch the transmitters in the idle state (rest period between transmitting data) to steady light (INVERS), to enable continuous fiber optic diagnostics.

If DIP 2 is set to "ON" (NORM), diagnostics are not available via the LED bar graph.

LED bar graph	Receive status	Optical power P_{opt}
Green Green Yellow	Very good	P_{opt} is considerably greater than the system reserve
Green Yellow	Good	P_{opt} is still greater than the system reserve
Yellow	Critical	P_{opt} has reached the system reserve
Red	Error	P_{opt} has sapped the system reserve/broken fiber

As soon as the system reserve is reached, only the yellow LED remains lit. At the same time, the signaling relay drops and the switch contact opens. Data communication is still possible.

Basic method of operation

The PSI-MOS device has a maximum of three interfaces for the RS-422 signal: the electrical interface (COMBICON connector), the fiber optic port, and the DIN rail connector (T-BUS).

7.1 Point-to-point connections

The COMBICON interface communicates directly with the fiber optic port. Communication with the DIN rail connector is disabled.

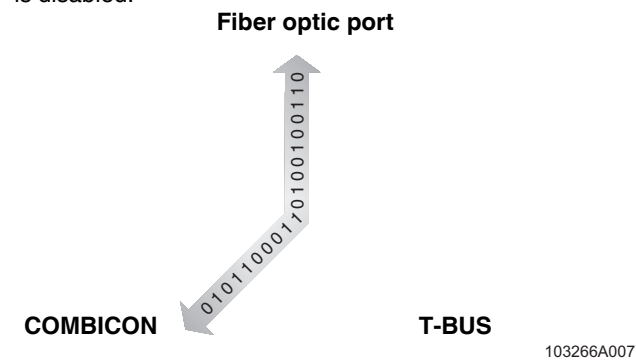

Figure 4 Communication between the interfaces for point-to-point connections, DIP 1 = "OFF" (LINE)

7.2 Star structures

All three interfaces (COMBICON, fiber optic port, and DIN rail connector) communicate directly with one another.

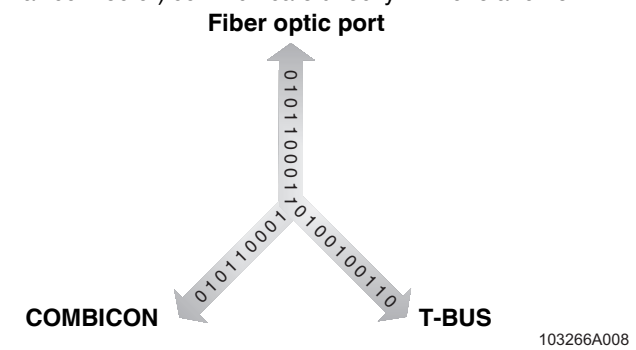

Figure 5 Communication between the interfaces for the star structure, DIP 1 = "ON" (STAR)

8 Configuration



NOTE: Electrostatic discharge

The device contains components that can be damaged or destroyed by electrostatic discharge. When handling the device, observe the necessary safety precautions against electrostatic discharge (ESD) according to EN 61340-5-1 and EN 61340-5-2.

- For configuration, release the housing cover using a screwdriver (A in Figure 6).
- Then carefully pull the PCB out of the housing as far as possible (B).

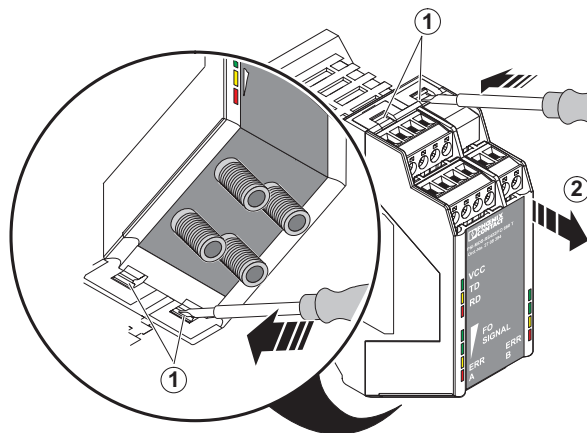

Figure 6 Opening the housing

DIP switches 1 to 4 are then freely accessible.

- Configure the DIP switches according to the planned application.

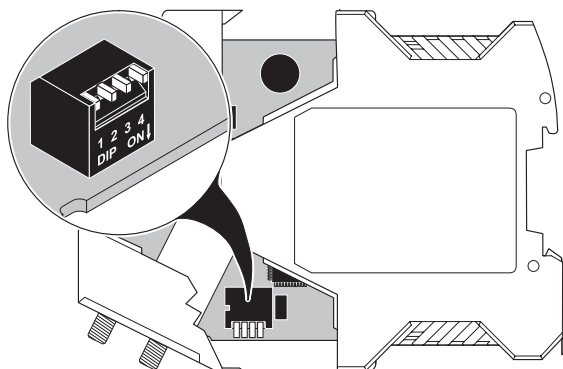

Figure 7 Setting the DIP switches

The following tables provide an overview of the DIP switch functions. By default upon delivery, all DIP switches are in the "OFF" position.



NOTE: After changing the device settings, disconnect the power to the device so that the settings can be applied.



NOTE: When using T-couplers with an INTERBUS line with 2 Mbps and activated redundancy mode (DIP 3 = "ON"), DIP 4 must be left set to "OFF", as otherwise a bus reset is triggered.

DIP switch	ON	OFF
1	STAR	LINE
2	NORM	INVERS
3	REDUNDANCY	–
4	END	NEXT

8.1 Operation in a point-to-point connection (DIP 1)

No further settings are required in the default setting.

- Leave all DIP switches in the "OFF" position.
- When using T-couplers, fiber optic port B must be deactivated.
- Set DIP 4 to "ON" (END).

8.2 Operation in a linear structure (DIP 1)



NOTE: Addressable RS-422/RS-485 4-wire devices and a suitable communication protocol are required for a linear structure.

Please note that the number of devices that can be cascaded depends on the transmission speed (see page 8).

First and last device in the line:

In the default setting, no further settings are required when two termination devices are used.

- Leave all DIP switches in the "OFF" position.
- When using T-couplers, fiber optic port B must be deactivated.
- Set DIP 4 to "ON" (END).

Devices along the line:

T-couplers must be used along the line.

By default upon delivery, no changes to the setting are required.

- Leave all DIP switches in the "OFF" position.

8.3 Operation in a star structure (DIP 1)

NOTE: Addressable RS-422/RS-485 4-wire devices and a suitable communication protocol are required for a star structure.

Devices in the star coupler topology

- For each device in the star coupler topology, set DIP 1 to "ON" (STAR).

Devices at the end of a star line

No further settings are required in the default setting.

- Leave all DIP switches in the "OFF" position.

8.4 Operation in an INTERBUS system

No further settings are required in the default setting.

- Leave DIP 1 set to "OFF" (LINE) and DIP 2 set to "OFF" (INVERS).

When using T-couplers, fiber optic port B must be deactivated.

- Set DIP 4 to "ON" (END).

8.5 Connection to fiber optic interfaces from third-party suppliers (DIP 2)

During the idle phase, fiber optic interfaces return to an idle setting defined by the manufacturer. This idle setting may vary for different manufacturers and devices. As fiber optic interfaces can only be operated together if they have the same idle setting, this should be set using the DIP switches.

For mixed operation of PSI-MOS with fiber optic interfaces from other manufacturers, proceed as follows.

- Check the idle setting for the third-party interface:
Logic 1 = Light off
Logic 1 = Light on
- If necessary, adjust the idle setting of PSI-MOS using DIP 2.

DIP 2	Idle setting	Meaning
OFF = INVERS	Light on ¹	Logic 1
ON = NORM	Light off	Logic 1

¹ Default setting



NOTE: If DIP 2 is set to "ON", fiber optic diagnostics are not available via the LED bar graph.

The LED bar graph can light up at high transmission speeds or flash at low transmission speeds. This display does **not** correspond to continuous evaluation of the optical power.



NOTE: When connecting third-party devices, observe the receiver sensitivity and overrange of the fiber optic interfaces.

8.6 Activating the redundancy function (DIP 3)

For increased availability, redundant fiber optic connections can be created using T-couplers. In this case, the redundancy function must be activated at the start and end of the redundant fiber optic connection.

- To do this, set DIP switch 3 (REDUNDANCY) to "ON".

When the redundancy function is enabled, data communication takes place via fiber optic port A by default. In the event that the signal level of the standard cable drops to a critical level, it automatically switches to port B.



NOTE: Always connect redundant fiber optic connections from fiber optic port A to port A of the opposite device or from port B to port B of the opposite device.

8.7 Disabling the second fiber optic port (DIP 4)

If the second fiber optic port (B) is not used for PSI-MOS-RS422/FO... T-couplers, it must be disabled. Otherwise the red "ERR" LED will light up.

- Set DIP 4 to "ON" (END).

9 Connection notes



WARNING: Only mount and remove devices when the power supply is disconnected.



WARNING: PSI-MOS-... devices are designed for SELV operation according to IEC 60950/EN 60950/VDE 0805.

- Install the device on a 35 mm DIN rail according to DIN EN 60715.
To avoid contact resistance only use clean, corrosion-free DIN rails.
- End clamps can be mounted on both sides of the device to stop the devices from slipping on the DIN rail (for ordering data, see page 3).



WARNING: Connect the DIN rail to protective earth ground using a grounding terminal block. The devices are grounded when they are snapped onto the DIN rail (installation according to PELV).

This ensures that the shielding is effective. Connect protective earth ground with low impedance.

9.1 Combined assembly with a system power supply unit (modular star coupler)

- Connect together the required number of DIN rail connectors for the connection station. Two DIN rail connectors are required for each device (see A in Figure 8). A maximum of ten devices are permitted in a connection station.
- Push the connected DIN rail connectors onto the DIN rail (B and C).
- Place the device onto the DIN rail from above. The upper holding keyway of the device must be hooked onto the top edge of the DIN rail (see Figure 8). Make sure that it is aligned correctly with the DIN rail connectors.
- Once the device has been snapped on properly, check that it is fixed securely on the DIN rail.

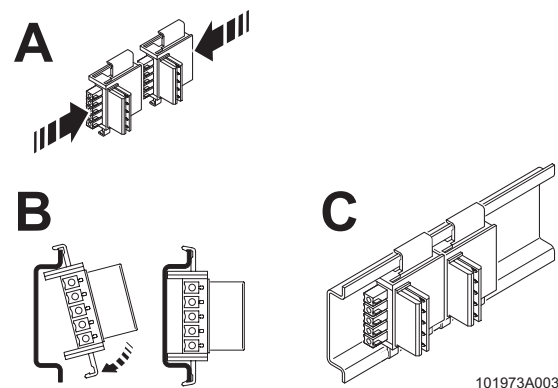

Figure 8 Combined assembly

9.2 Assembly as an individual device in the control cabinet (stand-alone)

- Place the device onto the DIN rail from above. The upper holding keyway of the device must be hooked onto the top edge of the DIN rail (see Figure 9).
- Push the device from the front towards the mounting surface.
- Once the device has been snapped on properly, check that it is fixed securely on the DIN rail.

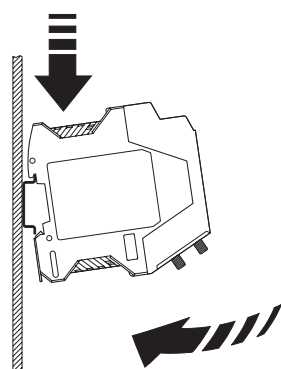

Figure 9 Assembly in the control cabinet

9.3 Assembly in potentially explosive areas



WARNING: Observe the safety notes on page 7.

- Areas with a danger of gas explosions
The devices are suitable for use in zone 2. Devices that are installed in zone 1 can be connected to the fiber optic interface. The fiber optic interface is an associated item of equipment with protection type "Ex op is".
- Areas with a danger of dust explosions
The device is **not** designed for installation in areas with a danger of dust explosions.
If dust is present, install the device in suitable, approved housing.
When installed outside areas with a danger of dust explosions, devices installed in zone 22 or 21 can also be connected to the fiber optic interface.

9.4 Removal

- Pull the locking latch down using a screwdriver, needle-nose pliers or similar.
- Pull the bottom edge of the module away from the mounting surface.
- Pull the module diagonally upwards away from the DIN rail.
- If removing a complete star distributor, remove the DIN rail connectors from the DIN rail as well.

10 Cabling notes

10.1 Connecting the supply voltage



WARNING: The device is operated with a +24 V DC SELV.

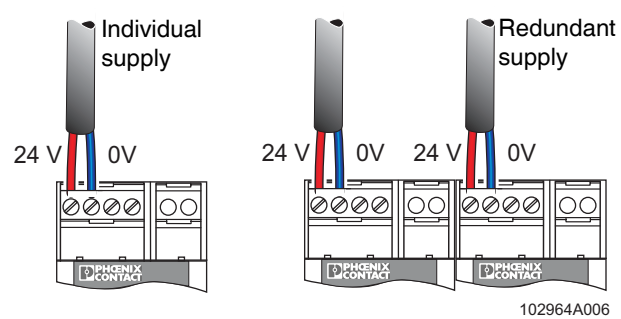

Figure 10 Individual/redundant supply

Operation as an individual device

Supply the supply voltage to the module via terminal blocks 1 (24 V) and 2 (0 V).

Operation in a star coupler topology

When the devices are operated in a star coupler topology, the supply voltage must only be supplied to the first device in the station. The remaining devices are supplied via the DIN rail connector. A redundant supply concept can be created by connecting a second power supply unit to another device in the topology.

Using the MINI POWER system power supply unit

As an alternative, the star coupler topology can also be supplied using the MINI-SYS-PS 100-240AC/24DC/1.5 (Order No. 2866983) or MINI-PS-100-240AC/24DC/1.5/EX (Order No. 2866653) system power supply unit. It is connected via two DIN rail connectors.

Usually the system power supply unit is mounted as the first device in a topology. A second power supply unit can be used to create a redundant supply concept.

10.2 Connecting the data cables/bus termination



NOTE: Use shielded twisted pair data cables. Connect the cable shielding at both ends of the transmission path.

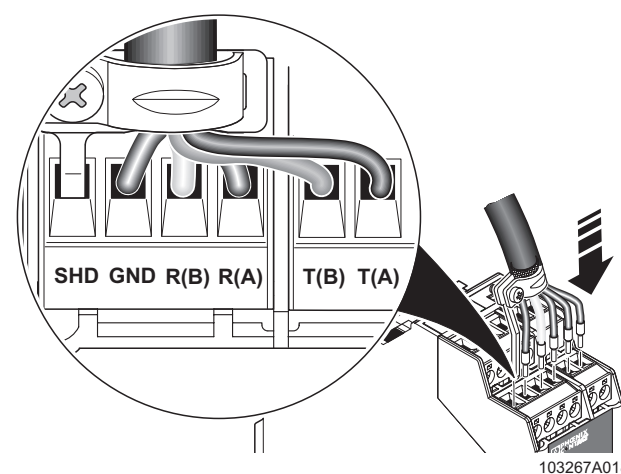

Figure 11 Shield connection

- Connect the cable shielding to terminal block 5.
- For optimum shield connection, use the supplied shield connection clamp.



NOTE: The maximum length of the RS-422/RS-485 cables depends on the transmission speed. The values listed in the table must not be exceeded.

Transmission speed [kbps]	Range [m]
187.5	1000
500	400
1500	200
12000	100

Use in INTERBUS systems

- Connect the INTERBUS connection to COMBICON terminal blocks 6 to 10.
- Please note the different pin assignment when connecting to REMOTE IN and REMOTE OUT.

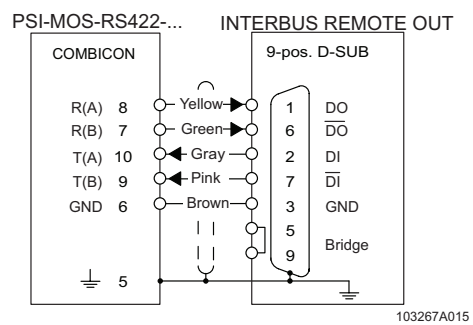

Figure 12 Connection to INTERBUS REMOTE OUT

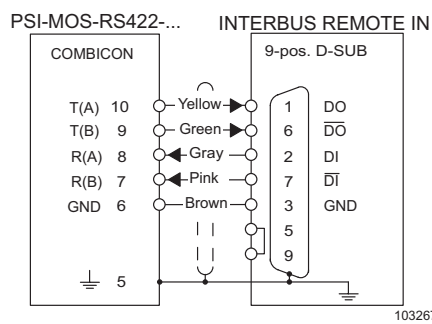

Figure 13 Connection to INTERBUS REMOTE IN

Use in RS-422/RS-485 4-wire applications



NOTE: Please note the crossover between transmit and receive cables.

- Connect the data cable to COMBICON terminal blocks 6 to 10.



NOTE: When using **RS-422 termination devices**, only one device may be connected to the electrical interface per PSI-MOS device.



NOTE: In **RS-485 master/slave networks**, either a master device or up to 31 slave devices may be connected to each PSI-MOS device. Master and slave devices must not be mixed in a common electrical segment.



NOTE: In **star coupler stations**, always connect the master device to the data interface of the first PSI-MOS device. Combined use of the data interfaces of the other PSI-MOS devices is not possible.

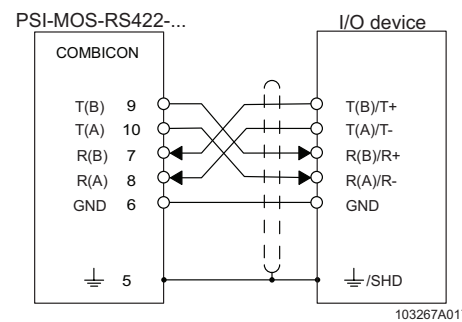

Figure 14 Connection to RS-422/RS-485 4-wire

10.3 Wiring the switch contact

PSI-MOS-RS422/FO... converters are equipped with a floating switch contact for error diagnostics (connection terminal blocks 3 and 4 in Figure 3 on page 9). This contact opens on the affected device if:

- The supply voltage fails
- An interrupt is detected on the fiber optic path
- The system reserve for the fiber optic path is not reached

The switch contact is an N/C contact and can be connected to a local digital input, e.g., on the PLC, to support error detection.

When using a device topology (modular star coupler), the individual contacts can be connected to separate input points or the individual contacts can be looped to generate a group message (Figure 15).



NOTE: The maximum load capacity of the relay contact is 60 V DC/42 V AC, 1 A.

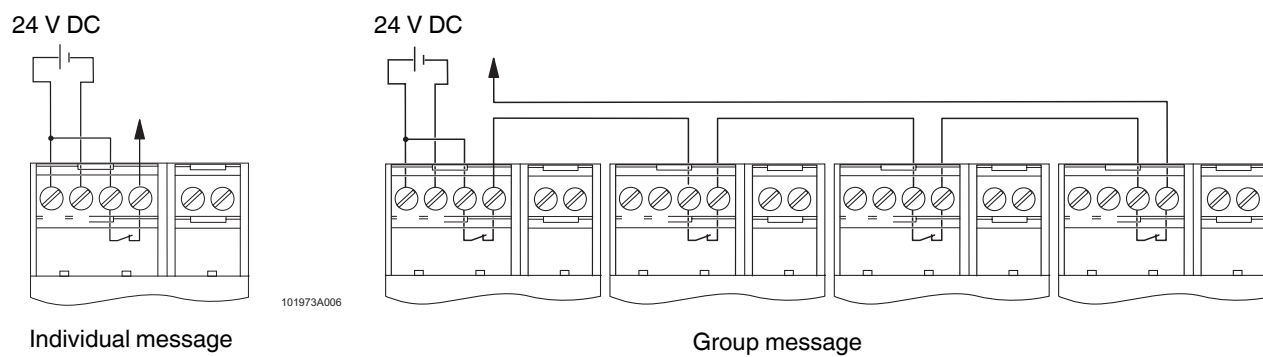

Figure 15 Individual and group message

10.4 Connecting the fiber optic cables



WARNING: Risk of eye injury

During operation, do not look directly into transmitter diodes or use visual aids to look into the glass fibers.
The infrared light is not visible.



NOTE: Dust protection caps should only be removed just before the connectors are connected. They prevent contamination of the transmit and receive elements.
The same applies for the protective caps on the connectors.



NOTE: The following fiber optic lengths must not be exceeded:

- PSI-MOS-RS422/FO 660 ...**
- 100 m with F-P 980/1000; 230 dB/km
 - 800 m with F-K 200/230; 10 dB/km
- PSI-MOS-RS422/FO 850 ...**
- 2800 m with F-K 200/230; 8 dB/km
 - 4200 m with F-G 50/125; 2.5 dB/km
 - 4200 m with F-G 62.5/125; 3.0 dB/km



NOTE: When using fiber optics, observe the fiber optic installation guidelines, DB GB IBS SYS FOC ASSEMBLY (Order No. 9393909).

F-SMA connection (PSI-MOS-RS422/FO 660 ...)

PSI-MOS-RS422/FO 660 ... devices use F-SMA connectors for the fiber optic connection. F-SMA is a standardized fiber optic connection.

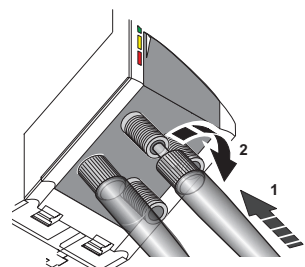

Figure 16 F-SMA connection

- The connectors are secured on the device by manually tightening the screw collar (see 2 in Figure 16).

B-FOC (ST®) connection (PSI-MOS-RS422/FO 850 ...)

Standardized B-FOC (ST®) connectors are used with PSI-MOS-RS422/FO 850 ... devices.

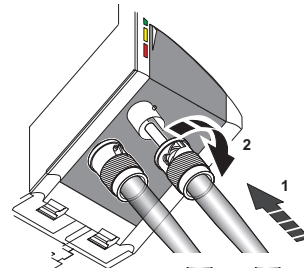

Figure 17 B-FOC connection

- Connect the fiber optic cable to the B-FOC (ST®) connector for the transmit and receive channel and push the connector clamp mechanism downwards.
- Secure the connection with a quarter turn to the right (see 2 in Figure 17).

Measuring and connecting devices

Due to the integrated optical diagnostics, there is no need to measure the path.



NOTE: Note the fiber optic cable signal direction when coupling two PSI-MOS devices:
Device 1 fiber connection "TD" (transmitter) to device 2 fiber connection "RD" (receiver) (Figure 18).



NOTE: Due to different operating wavelengths, PSI-MOS-RS422/FO 660 ..., PSI-MOS-RS422/FO 850 ..., and PSI-MOS-RS422/FO 1300 E devices should not be connected directly with one another via fiber optic cables.

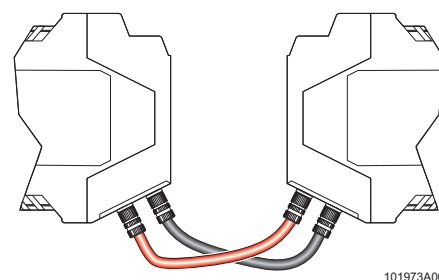

Figure 18 Crossed cables

Looking for pricing, stock, or lifecycle information?

Click below to explore more details on WIN SOURCE:

 [View 2708096 on WIN SOURCE](#)

 [Phoenix Contact](#) Information

Optimize Your Supply Chain with WIN SOURCE Solutions

-  Global Sourcing Solution
-  Obsolete Management
-  Cost Control Management
-  Shortage Management
-  Alternative Solution
-  Excess Inventory Management