



**THE DATASHEET OF
ZB6AD26**



Product data sheet

Specifications



Selector switch head, Harmony
9001SK, plastic, long handle, black,
30mm, 2 positions, stay put

9001SKS11FB

Main

Range of product	Harmony 9001SK
Product or component type	Head for selector switch
Device short name	9001SK
Type of operator	stay put
Operator profile	Black long handle

Complementary

Bezel material	Plastic
Mounting diameter	30 mm
Product weight	0.059 kg
Shape of signaling unit head	Octagonal
Operator position information	2 positions
Contacts type and composition	Without contact block
Mechanical durability	500000 cycles
Product compatibility	9001KA2, mounted side 1 or 2
Device presentation	Basic element
Cap/operator or lens colour	Black
Operator profile	Long handle
Type of operator	Stay put
Size	30 mm
Cam profile	5

Environment

Protective treatment	TC
Ambient air temperature for storage	-40...70 °C
Ambient air temperature for operation	-25...70 °C
Electrical shock protection class	Class II conforming to IEC 61140
IP degree of protection	IP66 conforming to IEC 60529

NEMA degree of protection	NEMA 1 NEMA 12 NEMA 13 NEMA 2 NEMA 3 NEMA 3R NEMA 4 NEMA 4X NEMA 6
Standards	CSA C22.2 No 14 JIS C 4520 IEC 60947-5-4 UL 508 IEC 60947-1 JIS C 852 IEC 60947-5-1
Product certifications	NEMA UL 508
Vibration resistance	7 gn (f= 2...500 Hz) conforming to IEC 60068-2-6
Shock resistance	50 gn conforming to IEC 60068-2-27

Packing Units

Unit Type of Package 1	PCE
Number of Units in Package 1	1
Package 1 Height	5.08 cm
Package 1 Width	5.842 cm
Package 1 Length	7.112 cm
Package 1 Weight	63.503 g
Unit Type of Package 2	S01
Number of Units in Package 2	24
Package 2 Height	15 cm
Package 2 Width	15 cm
Package 2 Length	40 cm
Package 2 Weight	1.641 kg

Contractual warranty

Warranty	18 months
-----------------	-----------

Environmental Data

Schneider Electric aims to achieve Net Zero status by 2050 through supply chain partnerships, lower impact materials, and circularity via our ongoing “Use Better, Use Longer, Use Again” campaign to extend product lifetimes and recyclability.

[Environmental Data explained >](#)

[How we assess product sustainability >](#)

Environmental footprint

[Environmental Disclosure](#)

[Product Environmental Profile](#)

Use Better

Materials and Substances

Packaging made with recycled cardboard

Yes

Packaging without single use plastic

Yes

[EU RoHS Directive](#)

Pro-active compliance (Product out of EU RoHS legal scope)

California proposition 65

WARNING: This product can expose you to chemicals including: Nickel compounds, which is known to the State of California to cause cancer, and Di-isodecyl phthalate (DIDP), which is known to the State of California to cause birth defects or other reproductive harm. For more information go to www.P65Warnings.ca.gov

Use Again

Repack and remanufacture

End of life manual availability

No need of specific recycling operations

Take-back

No

WEEE Label

 The product must be disposed on European Union markets following specific waste collection and never end up in rubbish bins

Dimensions Drawings

Dimensions

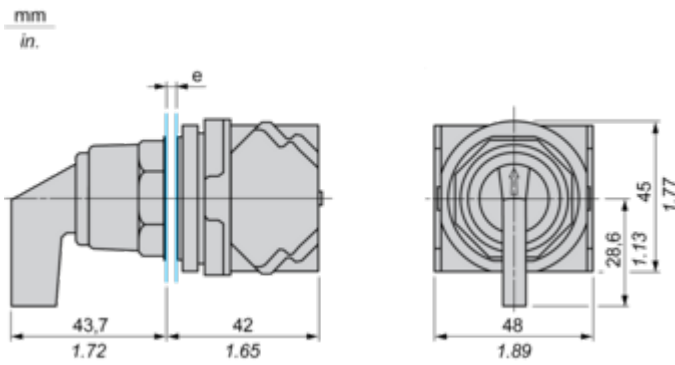

e panel thickness: 1 to 6 mm / 0.04 to 0.24 in.

Mounting and Clearance

Contact Block Mounting Position

Top and Rear views

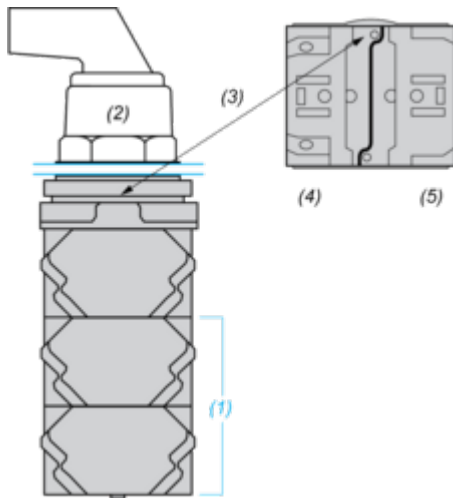

- (1) It is possible to mount up to 3 levels of contacts blocks (maximum of 6 contacts blocks)
- (2) Operator
- (3) Locating notch
- (4) Side 1
- (5) Side 2

Looking for pricing, stock, or lifecycle information?

Click below to explore more details on WIN SOURCE:

 [View ZB6AD26 on WIN SOURCE](#)

 [Schneider Electric](#) Information

Optimize Your Supply Chain with WIN SOURCE Solutions

-  Global Sourcing Solution
-  Obsolete Management
-  Cost Control Management
-  Shortage Management
-  Alternative Solution
-  Excess Inventory Management