

# BQ77216xx Voltage and Temperature Protection for 3-Series to 16-Series Cell Li-Ion Batteries with Internal Delay Timer

## 1 Features

- 3-series cell to 16-series cell protection
- High-accuracy overvoltage protection
  - $\pm 10\text{mV}$  at  $25^\circ\text{C}$
  - $\pm 20\text{mV}$  from  $0^\circ\text{C}$  to  $60^\circ\text{C}$
- Overvoltage protection options from 3.55V to 5.1V
- Undervoltage protection with options from 1.0V to 3.5V
- Open-wire connection detection
- Overtemperature protection
- Undertemperature protection
- Random cell connection
- Functional safety-capable
- Fixed internal delay timers
- Fixed detections thresholds
- Fixed output drive type for each of COUT and DOUT
  - Active high or active low
  - Active high drive to 6V
  - Open drain with the ability to be pulled up externally to VDD
- Low power consumption  $I_{CC} \approx 1\mu\text{A}$  ( $V_{\text{CELL(ALL)}} < V_{\text{OV}}$ )
- Low leakage current per cell input  $< 100\text{nA}$  with open wire detection disabled
- Package footprint options:
  - Leadless 24-pin TSSOP with 0.65mm lead pitch

## 2 Applications

- Protection for Li-ion battery packs used in:
  - [Handheld garden tools](#)
  - [Handheld power tools](#)
  - [Cordless vacuum cleaners](#)
  - [UPS battery backup](#)
  - [Light electric vehicles \(eBike, eScooter, pedal-assist bicycles\)](#)

## 3 Description

The BQ77216xx family of products provides a range of voltage and temperature monitoring, including overvoltage (OVP), undervoltage (UVP), open wire (OW), undertemperature (UT), and overtemperature (OT) protection for Li-ion battery pack systems. Each cell is monitored independently for overvoltage, undervoltage, and open-wire conditions. With the addition of an external NTC thermistor, the device can detect undertemperature and overtemperature conditions.

In the BQ77216xx device, an internal delay timer is initiated upon detection of an overvoltage, undervoltage, open-wire, undertemperature, or overtemperature condition. Upon expiration of the delay timer, the respective output is triggered into its active state (either high or low, depending on the configuration).

Overvoltage triggers the COUT pin if a fault is detected, and undervoltage triggers the DOUT pin if a fault is detected. If an overtemperature or open-wire fault is detected, then the DOUT and COUT are triggered. For quicker production-line testing, the BQ77216xx device provides a Customer Test Mode (CTM) with greatly reduced delay time.

### Package Information

PART NUMBER	PACKAGE	BODY SIZE (NOM)
BQ77216xx (1)	TSSOP (24)	4.40mm × 7.80mm (6.40mm × 7.80mm, including leads)

- (1) For available packages and preprogrammed device versions, see the orderable addendum at the end of the data sheet and the [Device Comparison Table](#).

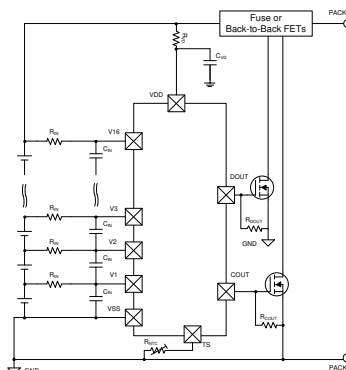

Simplified Schematic



## Table of Contents

<b>1 Features</b> .....	<b>1</b>	<b>8 Application and Implementation</b> .....	<b>14</b>
<b>2 Applications</b> .....	<b>1</b>	8.1 Application Information.....	14
<b>3 Description</b> .....	<b>1</b>	8.2 Systems Example.....	16
<b>4 Device Comparison Table</b> .....	<b>3</b>	<b>9 Power Supply Recommendations</b> .....	<b>17</b>
<b>5 Pin Configuration and Functions</b> .....	<b>5</b>	<b>10 Layout</b> .....	<b>18</b>
<b>6 Specifications</b> .....	<b>6</b>	10.1 Layout Guidelines.....	18
6.1 Absolute Maximum Ratings .....	6	10.2 Layout Example.....	18
6.2 ESD Ratings .....	6	<b>11 Device and Documentation Support</b> .....	<b>19</b>
6.3 Recommended Operating Conditions .....	6	11.1 Third-Party Products Disclaimer.....	19
6.4 Thermal Information .....	7	11.2 Receiving Notification of Documentation Updates..	19
6.5 DC Characteristics .....	7	11.3 Support Resources.....	19
6.6 Timing Requirements.....	9	11.4 Trademarks.....	19
<b>7 Detailed Description</b> .....	<b>10</b>	11.5 Electrostatic Discharge Caution.....	19
7.1 Overview.....	10	11.6 Glossary.....	19
7.2 Functional Block Diagram.....	10	<b>12 Revision History</b> .....	<b>20</b>
7.3 Feature Description.....	10	<b>13 Mechanical, Packaging, and Orderable</b>	
7.4 Device Functional Modes.....	12	<b>Information</b> .....	<b>20</b>

## 4 Device Comparison Table

**Table 4-1. BQ77216xx Device Comparison**

PART NUMBER	T <sub>A</sub>	PACKAGE	PACKAGE DESIGNATOR	OVP (V)	OV HYSTERESIS (V)	OVP DELAY	UVP (V)	UVP DELAY
BQ7721600	–40°C to 110°C	24-Pin TSSOP	PW	4.325	0.100	1s	2.25	1s
BQ7721602	–40°C to 110°C	24-Pin TSSOP	PW	4.325	0.100	1s	2.25	1s
BQ7721603	–40°C to 110°C	24-Pin TSSOP	PW	4.3	0.100	2s	2	2s
BQ7721605	–40°C to 110°C	24-Pin TSSOP	PW	4.225	0.100	1s	2.6	1s
BQ7721606	–40°C to 110°C	24-Pin TSSOP	PW	4.275	0.100	1s	2.5	1s
BQ7721607	–40°C to 110°C	24-Pin TSSOP	PW	4.25	0.100	4s	2.5	2s
BQ7721609	–40°C to 110°C	24-Pin TSSOP	PW	4.35	0.200	4s	Disabled	
BQ7721610	–40°C to 110°C	24-Pin TSSOP	PW	4.25	0.100	4s	2.5	2s
BQ7721611	–40°C to 110°C	24-Pin TSSOP	PW	3.8	0.200	4s	1.5	1s
BQ7721612	–40°C to 110°C	24-Pin TSSOP	PW	3.6	0.200	2s	2.0	2s
BQ7721613	–40°C to 110°C	24-Pin TSSOP	PW	4.25	0.100	4s	2.0	2s
BQ7721614	–40°C to 110°C	24-Pin TSSOP	PW	3.9	0.100	4s	1.85	2s
BQ7721615	–40°C to 110°C	24-Pin TSSOP	PW	4.23	0.100	4s	2.0	2s
BQ7721616	–40°C to 110°C	24-Pin TSSOP	PW	4.18	0.100	4s	2.0	2s
BQ7721617	–40°C to 110°C	24-Pin TSSOP	PW	3.8	0.100	2s	1.5	2s
BQ7721618	–40°C to 110°C	24-Pin TSSOP	PW	4.22	0.200	4s	2.2	2s
BQ7721619	–40°C to 110°C	24-Pin TSSOP	PW	4.22	0.200	2s	2.1	1s
BQ7721620	–40°C to 110°C	24-Pin TSSOP	PW	3.7	0.100	1s	1.8	2s
BQ77216xx <sup>(1)</sup>	–40°C to 110°C	24-Pin TSSOP	PW	3.55 – 5.10	0.100, 0.200	0.25s, 0.5s, 1s, 2s, 4s	1.0 – 3.5	0.25s, 0.5s, 1s, 2s

**Table 4-2. BQ77216xx Device Comparison (continued)**

PART NUMBER	UV HYSTERESIS (V)	OTC (°C)	UTC (°C)	OW	LATCH	OUTPUT DRIVE	TAPE AND REEL
BQ7721600	0.100	70	NA	Enabled	Disabled	Active Low	BQ7721600PWR
BQ7721602	0.100	70	NA	Enabled	Disabled	Active High, 6V Drive	BQ7721602PWR
BQ7721603	0.100	75	NA	Enabled	Disabled	Active High, 6V Drive	BQ7721603PWR
BQ7721605	0.200	75	NA	Disabled	Disabled	Active High, 6V Drive	BQ7721605PWR
BQ7721606	0.200	75	NA	Disabled	Disabled	Active High, 6V Drive	BQ7721606PWR
BQ7721607	0.100	83	-30	Enabled	Disabled	Active High, 6V Drive	BQ7721607PWR
BQ7721609	Disabled	83	NA	Enabled	Disabled	Active High, 6V Drive	BQ7721609PWR
BQ7721610	0.100	83	NA	Enabled	Disabled	Active High, 6V Drive (COU) Active Low (DOU)	BQ7721610PWR
BQ7721611	0.200	70	NA	Disabled	Disabled	Active High, 6V Drive	BQ7721611PWR
BQ7721612	0.200	75	NA	Disabled	Disabled	Active Low	BQ7721612PWR
BQ7721613	0.200	83	-30	Enabled	Disabled	Active High, 6V Drive	BQ7721613PWR
BQ7721614	0.100	75	NA	Enabled	Disabled	Active High, 6V Drive	BQ7721614PWR
BQ7721615	0.200	83	-20	Disabled	Disabled	Active High, 6V Drive	BQ7721615PWR
BQ7721616	0.200	80	-20	Disabled	Disabled	Active High, 6V Drive	BQ7721616PWR
BQ7721617	0.200	NA	NA	Disabled	Disabled	Active High, 6V Drive	BQ7721617PWR
BQ7721618	0.200	83	-20	Disabled	Disabled	Active High, 6V Drive	BQ7721618PWR
BQ7721619	0.200	83	-10	Disabled	Disabled	Active High, 6V Drive	BQ7721619PWR
BQ7721620	0.200	83	-10	Disabled	Disabled	Active High, 6V Drive	BQ7721620PWR
BQ77216xx <sup>(1)</sup>	0.100, 0.200	62, 65, 70, 75, 80, 83, Disabled	-30, -20, -10, 0, Disabled	Enabled, Disabled	Enabled, Disabled	Open Drain Active Low, Active High 6V, Active High VDD	TBD

(1) Contact TI for more information.

## 5 Pin Configuration and Functions

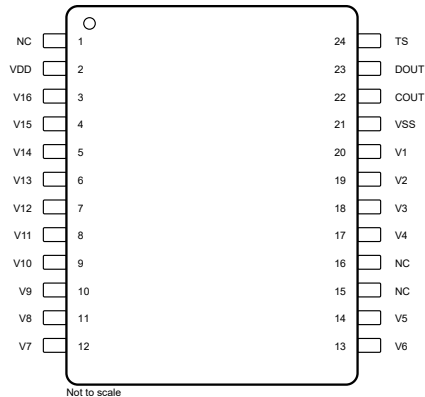

**Table 5-1. 24-Lead Pin Functions**

NO.	NAME	TYPE	DESCRIPTION <sup>(1)</sup>
1	NC	—	Not electrically connected and can be left floating
2	VDD	P	Power supply
3	V16	I	Sense input for positive voltage of the sixteenth cell from the bottom of the stack
4	V15	I	Sense input for positive voltage of the fifteenth cell from the bottom of the stack
5	V14	I	Sense input for positive voltage of the fourteenth cell from the bottom of the stack
6	V13	I	Sense input for positive voltage of the thirteenth cell from the bottom of the stack
7	V12	I	Sense input for positive voltage of the twelfth cell from the bottom of the stack
8	V11	I	Sense input for positive voltage of the eleventh cell from the bottom of the stack
9	V10	I	Sense input for positive voltage of the tenth cell from the bottom of the stack
10	V9	I	Sense input for positive voltage of the ninth cell from the bottom of the stack
11	V8	I	Sense input for positive voltage of the eighth cell from the bottom of the stack
12	V7	I	Sense input for positive voltage of the seventh cell from the bottom of the stack
13	V6	I	Sense input for positive voltage of the sixth cell from the bottom of the stack
14	V5	I	Sense input for positive voltage of the fifth cell from the bottom of the stack
15	NC	—	Not electrically connected and can be left floating
16	NC	—	Not electrically connected and can be left floating
17	V4	I	Sense input for positive voltage of the fourth cell from the bottom of the stack
18	V3	I	Sense input for positive voltage of the third cell from the bottom of the stack
19	V2	I	Sense input for positive voltage of the second cell from the bottom of the stack
20	V1	I	Sense input for positive voltage of the lowest cell in the stack
21	VSS	P	Electrically connected to IC ground and negative terminal of the lowest cell in the stack
22	COUT	O	Output drive for overvoltage, open wire, undertemperature, and overtemperature. It can be left floating if not used.
23	DOUT	O	Output drive for undervoltage, open wire, undertemperature, and overtemperature. It can be left floating if not used.
24	TS	I	Temperature sensor input. If not used, connect it with a 10kΩ resistor to VSS.

(1) I = Input, O = Output, P = Power Connection

## 6 Specifications

### 6.1 Absolute Maximum Ratings

over operating free-air temperature range (unless otherwise noted)<sup>(1)</sup>

		MIN	MAX	UNIT
Supply voltage range	VDD – VSS	–0.3	85	V
Input voltage range	Vn – VSS where n = 1 to 16	–0.3	85	V
	TS	–0.3	1.5	V
Output voltage range	COUT – VSS, DOUT – VSS	–0.3	85	V
Functional temperature, T <sub>FUNC</sub>		–40	110	°C
Storage temperature, T <sub>STG</sub>		–65	150	°C

- (1) Operation outside the Absolute Maximum Ratings may cause permanent device damage. Absolute Maximum Ratings do not imply functional operation of the device at these or any other conditions beyond those listed under Recommended Operating Conditions. If outside the Recommended Operating Conditions but within the Absolute Maximum Ratings, the device may not be fully functional, and this may affect device reliability, functionality, performance, and shorten the device lifetime.

### 6.2 ESD Ratings

			VALUE	UNIT
V <sub>(ESD)</sub>	Electrostatic discharge	Human body model (HBM), per ANSI/ESDA/ JEDEC JS-001, all pins <sup>(1)</sup>	±2000	V
		Charged device model (CDM), per ANSI/ESDA/ JEDEC JS-002, all pins	±500	

- (1) JEDEC document JEP155 states that 500V HBM allows safe manufacturing with a standard ESD control process.

### 6.3 Recommended Operating Conditions

over operating free-air temperature range (unless otherwise noted)

		MIN	NOM	MAX	UNIT
V <sub>DD</sub>	Supply voltage <sup>(1)</sup>	5		75	V
V <sub>IN</sub>	Input voltage range of Vn - Vn-1 where n = 2 to 16 and V1 - VSS	0		5	V
	TS	0		1.5	V
V <sub>CTM</sub>	Customer Test Mode Entry V <sub>DD</sub> > V16 + V <sub>CTM</sub>	12		13	V
C <sub>TS</sub>	Total capacitance on the TS Pin			200	pF
T <sub>A</sub>	Ambient temperature	–40		85	°C
T <sub>J</sub>	Junction temperature	–65		150	°C

- (1) V<sub>DD</sub> is equal to top of stack voltage

## 6.4 Thermal Information

THERMAL METRIC <sup>(1)</sup>		DEVICE	UNIT
		PW (TSSOP)	
		24 PINS	
R <sub>θJA</sub>	Junction-to-ambient thermal resistance	97.8	°C/W
R <sub>θJC(top)</sub>	Junction-to-case (top) thermal resistance	40.5	°C/W
R <sub>θJB</sub>	Junction-to-board thermal resistance	53.1	°C/W
Ψ <sub>JT</sub>	Junction-to-top characterization parameter	4.3	°C/W
Ψ <sub>JB</sub>	Junction-to-board characterization parameter	52.7	°C/W
R <sub>θJC(bot)</sub>	Junction-to-case (bottom) thermal resistance	NA	°C/W

(1) For more information about traditional and new thermal metrics, see the [Semiconductor and IC Package Thermal Metrics](#) application note.

## 6.5 DC Characteristics

Typical values stated where T<sub>A</sub> = 25°C and VDD = 58V, MIN/MAX values stated where T<sub>A</sub> = –40°C to 85°C and VDD = 5V to 75V (unless otherwise noted).

PARAMETER		TEST CONDITIONS	MIN	TYP	MAX	UNIT
<b>OVER VOLTAGE PROTECTION (OV)</b>						
V <sub>OV</sub>	OV Detection Range		3.55		5.1	V
V <sub>OV_STEP</sub>	OV Detection Steps			25		mV
V <sub>OV_HYS</sub>	OV Detection Hysteresis	Selected OV Hysteresis depends on the part number. See the device selection table for details.		V <sub>OV</sub> – 100		mV
		Selected OV Hysteresis depends on the part number. See the device selection table for details.		V <sub>OV</sub> – 200		mV
V <sub>OV_ACC</sub>	OV Detection Accuracy	T <sub>A</sub> = 25°C	–10		10	mV
	OV Detection Accuracy	0°C ≤ T <sub>A</sub> ≤ 60°C	–20		20	mV
	OV Detection Accuracy	–40°C ≤ T <sub>A</sub> ≤ 110°C	–50		50	mV
<b>UNDER VOLTAGE PROTECTION (UV)</b>						
V <sub>UV</sub>	UV Detection Range		1.0		3.5	V
V <sub>UV_STEP</sub>	UV Detection Steps			50		mV
V <sub>UV_HYS</sub>	UV Detection Hysteresis	Selected UV Hysteresis depends on the part number. See the device selection table for details.		V <sub>UV</sub> + 100		mV
		Selected UV Hysteresis depends on the part number. See the device selection table for details.		V <sub>UV</sub> + 200		mV
V <sub>UV_ACC</sub>	UV Detection Accuracy	T <sub>A</sub> = 25°C	–30		30	mV
	UV Detection Accuracy	–40 ≤ T <sub>A</sub> ≤ 110°C	–50		50	mV
V <sub>UV_MIN</sub>	UV Detection Disabled Threshold	V <sub>n</sub> – V <sub>n-1</sub> where n = 2 to 16 and V1 – VSS	450	500	550	mV
<b>OVER TEMPERATURE PROTECTION (OT)</b>						
T <sub>OT</sub>	OT Detection Range	Available options: 62°C, 65°C, 70°C, 75°C, 80°C, 83°C	62.0		83.0	°C

## 6.5 DC Characteristics (continued)

Typical values stated where  $T_A = 25^\circ\text{C}$  and  $V_{DD} = 58\text{V}$ , MIN/MAX values stated where  $T_A = -40^\circ\text{C}$  to  $85^\circ\text{C}$  and  $V_{DD} = 5\text{V}$  to  $75\text{V}$  (unless otherwise noted).

PARAMETER		TEST CONDITIONS	MIN	TYP	MAX	UNIT
R <sub>OT_EXT</sub>	OT Detection External Resistance	62°C		2850		Ω
		65°C		2570		
		70°C		2195		
		75°C		1915		
		80°C		1651		
		83°C		1525		
T <sub>OT_ACC</sub> (1)	OT Detection Accuracy		-5		5	°C
T <sub>OT_HYS</sub> (2)	OT Detection Hysteresis			-10		°C
				4186		Ω
				3530		Ω
R <sub>NTC</sub>	Internal Pullup Resistor	After TI Factory Trim	19.5	20	20.6	kΩ
<b>OPEN WIRE PROTECTION (OW)</b>						
V <sub>OW</sub>	OW Detection Threshold	V <sub>n</sub> < V <sub>n-1</sub> where n = 2 to 16		-200		mV
		V1 – VSS		500		mV
V <sub>OW_HYS</sub>	OW Detection Hysteresis	V <sub>n</sub> < V <sub>n-1</sub> where n = 1 to 16		V <sub>OW</sub> +100		mV
V <sub>OW_ACC</sub>	OW Detection Accuracy	-40 °C ≤ T <sub>A</sub> ≤ 110°C	-25		25	mV
<b>SUPPLY AND LEAKAGE CURRENT</b>						
I <sub>CC</sub>	Supply Current	No fault detected		2	3.5	μA
I <sub>IN</sub> (2)	Input Current at V <sub>x</sub> Pins	V <sub>n</sub> – V <sub>n-1</sub> and V1 – VSS = 4V, where n = 2 to 16, Open Wire Enabled	-0.3		0.3	μA
		V <sub>n</sub> – V <sub>n-1</sub> and V1 – VSS = 4V, where n = 2 to 16, Open Wire Disabled	-0.1		0.1	μA
<b>OUTPUT DRIVE, COUT and DOUT, CMOS ACTIVE HIGH VERSIONS ONLY</b>						
V <sub>OUT_AH</sub>	Output Drive Voltage for COUT and DOUT, Active High 6V	V <sub>n</sub> – V <sub>n-1</sub> or V1 – VSS > V <sub>OV</sub> , where n = 2 to 16, VDD = 58V, I <sub>OH</sub> = 100μA measured out of COUT, DOUT pin	6			V
		VDD – V <sub>COUT</sub> or V <sub>DOUT</sub> , V <sub>n</sub> – V <sub>n-1</sub> or V1 – VSS > V <sub>OV</sub> , where n = 2 to 16, I <sub>OH</sub> = 10μA measured out of COUT, DOUT pin	0	1	1.5	V
		VDD – V <sub>COUT</sub> or V <sub>DOUT</sub> , if 15 of 16 cells are short-circuited and only one cell remains powered and > V <sub>OV</sub> , VDD = V <sub>x</sub> (cell voltage), I <sub>OH</sub> = 100μA,	0	1	1.5	V
		V <sub>n</sub> – V <sub>n-1</sub> and V1 – VSS < V <sub>OV</sub> , where n = 2 to 16, VDD = 58V, I <sub>OH</sub> = 100μA measured into pin		250	400	mV
R <sub>OUT_AH</sub>	Internal Pullup Resistor		80	100	120	kΩ
I <sub>OUT_AH_H</sub>	OUT Source Current (during OV)	V <sub>n</sub> – V <sub>n-1</sub> or V1 – VSS > V <sub>OV</sub> , where n = 2 to 16, VDD = 58V, OUT = 0V. Measured out of COUT, DOUT pin			4.5	mA
I <sub>OUT_AH_L</sub>	OUT Sink Current (no OV)	V <sub>n</sub> – V <sub>n-1</sub> and V1 – VSS < V <sub>OV</sub> , where n = 2 to 16, VDD = 58V, OUT = VDD. Measured into COUT, DOUT pin	0.3		3	mA
<b>OUTPUT DRIVE, COUT and DOUT, NCH OPEN DRAIN ACTIVE LOW VERSIONS ONLY</b>						
V <sub>OUT_AL</sub>	Output Drive Voltage for COUT and DOUT, Active Low	V <sub>n</sub> – V <sub>n-1</sub> or V1 – VSS > V <sub>OV</sub> , where n = 2 to 16, VDD = 58V, I <sub>OH</sub> = 100μA measured into COUT, DOUT pin		250	400	mV

## 6.5 DC Characteristics (continued)

Typical values stated where  $T_A = 25^\circ\text{C}$  and  $V_{DD} = 58\text{V}$ , MIN/MAX values stated where  $T_A = -40^\circ\text{C}$  to  $85^\circ\text{C}$  and  $V_{DD} = 5\text{V}$  to  $75\text{V}$  (unless otherwise noted).

PARAMETER		TEST CONDITIONS	MIN	TYP	MAX	UNIT
$I_{\text{OUT\_AL\_L}}$	OUT Source Current (during OV)	$V_n - V_{n-1}$ or $V_1 - V_{SS} > V_{\text{OV}}$ , where $n = 2$ to $16$ , $V_{DD} = 58\text{V}$ , $\text{OUT} = V_{DD}$ . Measured into COUT, DOUT pin	0.3		3	mA
$I_{\text{OUT\_AL\_H}}$	OUT Sink Current (no OV)	$V_n - V_{n-1}$ and $V_1 - V_{SS} < V_{\text{OV}}$ , where $n = 2$ to $16$ , $V_{DD} = 58\text{V}$ , $\text{OUT} = V_{DD}$ . Measured out of COUT, DOUT pin			100	nA

- (1) Assured by Design. This accuracy assumes the external resistance is within  $\pm 2\%$  of the  $R_{\text{OT\_EXT}}$  values for the corresponding temperature threshold.
- (2) Assured by Design

## 6.6 Timing Requirements

Typical values stated where  $T_A = 25^\circ\text{C}$  and  $V_{DD} = 58\text{V}$ , MIN/MAX values stated where  $T_A = -40^\circ\text{C}$  to  $85^\circ\text{C}$  and  $V_{DD} = 5\text{V}$  to  $85\text{V}$  (unless otherwise noted).

PARAMETER		TEST CONDITIONS	MIN	TYP	MAX	UNIT
$t_{\text{OV\_DELAY}}$	OV Delay Time			0.25		s
				0.5		s
				1		s
				2		s
				4		s
$t_{\text{UV\_DELAY}}$	UV Delay Time			0.25		s
				0.5		s
				1		s
				2		s
$t_{\text{OT\_DELAY}}$	OT Delay Time		4		s	
$t_{\text{OW\_DELAY}}$	OW Delay Time		4		s	
$t_{\text{DELAY\_ACC}}$	Delay Time Accuracy	For 0.25s, 0.5s delays	-128		128	ms
$t_{\text{DELAY\_ACC}}$	Delay Time Accuracy	For 1s delays	-150		150	ms
$t_{\text{DELAY\_DR}}$	Delay time drift across operating temp	For all delays other than 0.25s, 0.5s, 1s delays	-10%		10%	
$t_{\text{CTM\_DELAY}}$	Fault Detection Delay Time during Customer Test Mode	See Customer Test Mode.		50		ms

## 7 Detailed Description

### 7.1 Overview

The BQ77216xx family of devices provides a range of voltage and temperature monitoring including overvoltage (OVP), undervoltage (UVP), open wire (OW), and overtemperature (OT) protection for Li-ion battery pack systems. Each cell is monitored independently for overvoltage, undervoltage, and open-wire conditions. With the addition of an external NTC thermistor, the device can detect overtemperature conditions. An internal delay timer is initiated upon detection of an overvoltage, undervoltage, open-wire, or overtemperature condition. Upon expiration of the delay timer, the respective output is triggered into its active state (either high or low, depending on the configuration). The overvoltage triggers the COUT pin if a fault is detected, and undervoltage triggers the DOUT pin if a fault is detected. If an undertemperature, overtemperature, or open-wire fault is detected, then both the DOUT and COUT are triggered.

For quicker production-line testing, the BQ77216xx device provides a Customer Test Mode (CTM) with greatly reduced delay time.

### 7.2 Functional Block Diagram

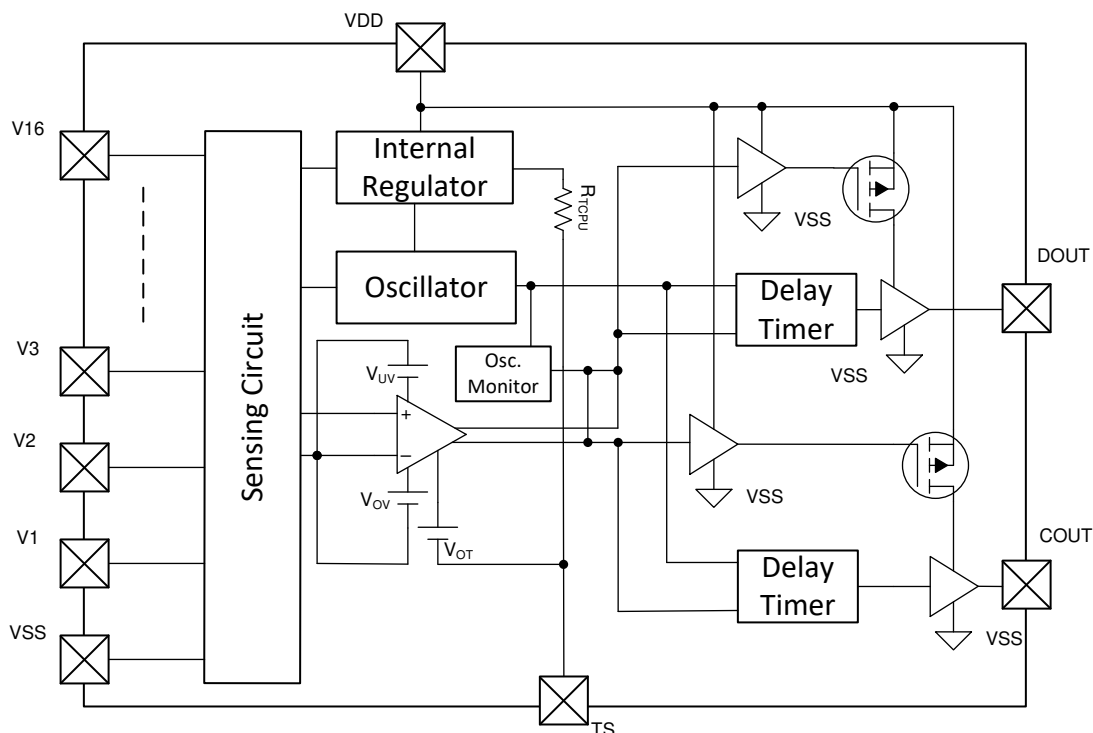

### 7.3 Feature Description

#### 7.3.1 Voltage Fault Detection

In the BQ77216xx device, each cell is monitored independently. Overvoltage is detected by comparing the actual cell voltage to a protection voltage reference,  $V_{OV}$ . If any cell voltage exceeds the programmed OV value, a timer circuit is activated. When the timer expires, the COUT pin goes from inactive to active state. The timer is reset if the cell voltage falls below the recovery threshold ( $V_{OV} - V_{OV\_HYS}$ ). Undervoltage is detected by comparing the actual cell voltage to a protection voltage reference,  $V_{UV}$ . If any cell voltage falls below the programmed UV value, a timer circuit is activated. When the timer expires, the DOUT pin goes from inactive to active state. The timer is reset if the cell voltage rises below the recovery threshold ( $V_{UV} + V_{UV\_HYS}$ ).

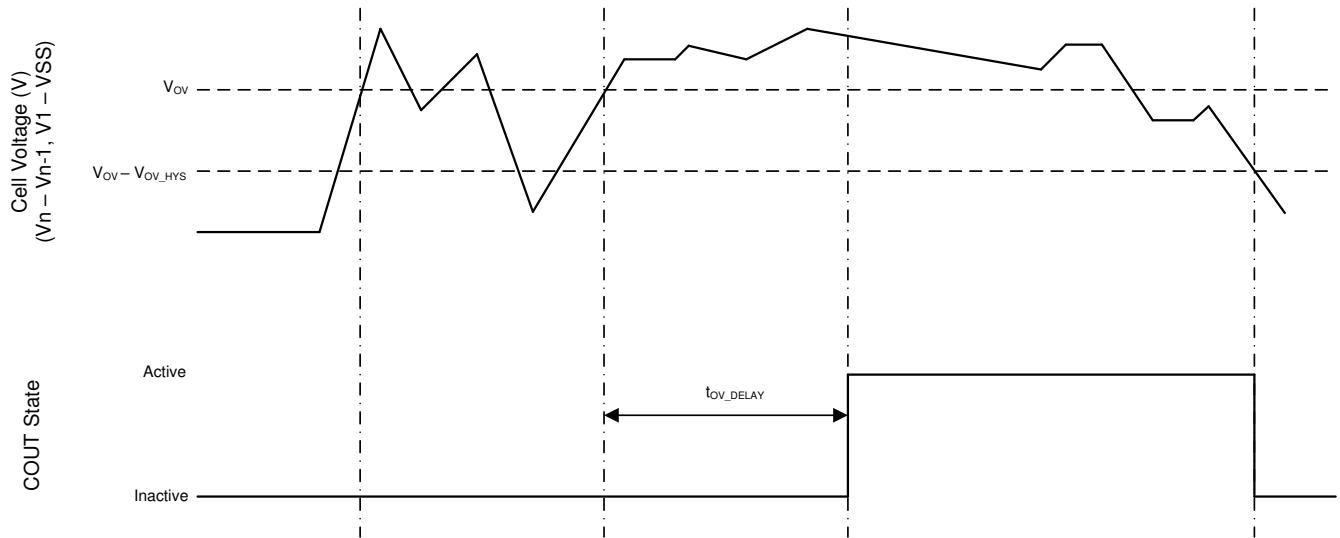

Figure 7-1. Timing for Overvoltage Sensing

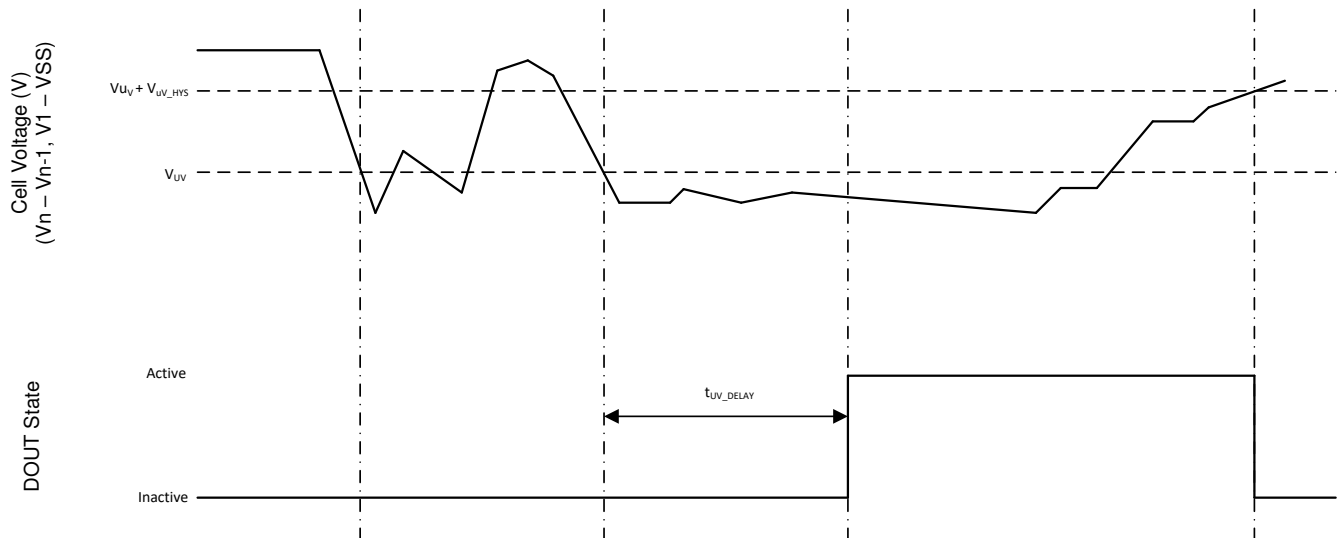

Figure 7-2. Timing for Undervoltage Sensing

### 7.3.2 Open-Wire Fault Detection

In the BQ77216xx device, each cell input is monitored independently to determine if the input is connected to a cell or not by applying a  $50\mu\text{A}$  pull down current to ground that is activated for  $128\mu\text{s}$  every  $128\text{ms}$ . If the device detects that  $V_n < V_{n-1} - V_{OV}$  V, then a timer is activated. When the timer expires, the COUT and DOUT pins go from an inactive to active state. The timer is reset if the cell input rises above or below the recovery threshold ( $V_{OV} + V_{OV\_HYS}$ ).

### 7.3.3 Temperature Fault Detection

In the BQ77216xx device, the TS pin is ratiometrically monitored with an internal pullup resistance  $R_{NTC}$ . Overtemperature is detected by evaluating the TS input voltage to determine the external resistance falls below a protection resistance,  $R_{OT\_EXT}$ . If the resistance falls below the programmed OT value, a timer circuit is activated. When the timer expires, the COUT and DOUT pins go from inactive to active state. The timer is reset if the resistance rises above the recovery threshold ( $R_{OT} + R_{OT\_HYS}$ ). Under temperature is detected by evaluating the TS input voltage to determine the external resistance falls below a protection resistance,  $R_{UT\_EXT}$ . If the resistance rises above the programmed UT value, a timer circuit is activated. When the timer expires, the

COUT and DOUT pins go from inactive to active state. The timer is reset if the resistance falls below above the recovery threshold ( $R_{OT} - R_{OT\_HYS}$ ) If external capacitance is added to the TS pin, it needs to be within the spec limit shown in recommended operating conditions.

---

#### Note

Texas Instruments does not recommend adding an external capacitor to the TS pin. The capacitance on this pin will affect the TS measurement accuracy if greater than  $C_{TS}$ .

---

#### 7.3.4 Oscillator Health Check

The device can detect if the internal oscillator slows down below the  $f_{OSC\_FAULT}$  threshold. When this occurs then the COUT and DOUT go from inactive to active state. If the oscillator returns to normal then the fault recovers.

#### 7.3.5 Sense Positive Input for $V_x$

This is an input to sense each single battery cell voltage. A series resistor and a capacitor across the cell for each input are required for noise filtering and stable voltage monitoring.

#### 7.3.6 Output Drive, COUT and DOUT

These pins serve as the fault signal outputs and may be ordered in either active HIGH with drive to 6V or active LOW options configured through internal OTP.

The COUT and DOUT respond per the following table when a fault is detected if the specific fault is enabled.

**Table 7-1. Fault Detection vs COUT and DOUT Action**

FAULT Detected	COUT	DOUT
Overvoltage	Active	Inactive
Undervoltage	Inactive	Active
Open Wire	Active	Active
Overtemperature	Active	Active
Oscillator Health	Active	Active

#### 7.3.7 The LATCH Function

The device can be enabled to latch the fault signal, which effectively disables the recovery functions of all fault detections. The only way to recover from a fault state when the latch is enabled is a POR of the device.

#### 7.3.8 Supply Input, VDD

This pin is the unregulated input power source for the IC. A series resistor is connected to limit the current, and a capacitor is connected to ground for noise filtering.

### 7.4 Device Functional Modes

#### 7.4.1 NORMAL Mode

When COUT and DOUT are inactive (no fault detected), the device operates in NORMAL mode and monitors for voltage, open-wire, and temperature faults.

The COUT and DOUT pins are inactive and if configured:

- Active high is low.
- Active low is being externally pulled up and is an open drain.

#### 7.4.2 FAULT Mode

FAULT mode is entered if the COUT or DOUT pins are activated. The OUT pin is either pulled high internally if configured as active high or is pulled low internally if configured as active low. When COUT and DOUT are deactivated, the device returns to NORMAL mode.

### 7.4.3 Customer Test Mode

Customer Test Mode (CTM) helps to reduce test time for checking the delay timer parameter once the circuit is implemented in the battery pack. To enter CTM, VDD should be set to at least  $V_{CTM}$  higher than V16 (see Figure 7-3). The delay timer is greater than 10ms, but considerably shorter than the timer delay in normal operation. To exit Customer Test Mode, remove the VDD to a V16 voltage differential of 10V so that the decrease in this value automatically causes an exit.

**CAUTION**

Avoid exceeding any Absolute Maximum Voltages on any pins when placing the part into Customer Test Mode. Also avoid exceeding Absolute Maximum Voltages for the individual cell voltages ( $V_{Cn}-V_{Cn-1}$ ) and ( $V1-VSS$ ). Stressing the pins beyond the rated limits may cause permanent damage to the device.

Figure 7-3 shows the timing for the Customer Test Mode.

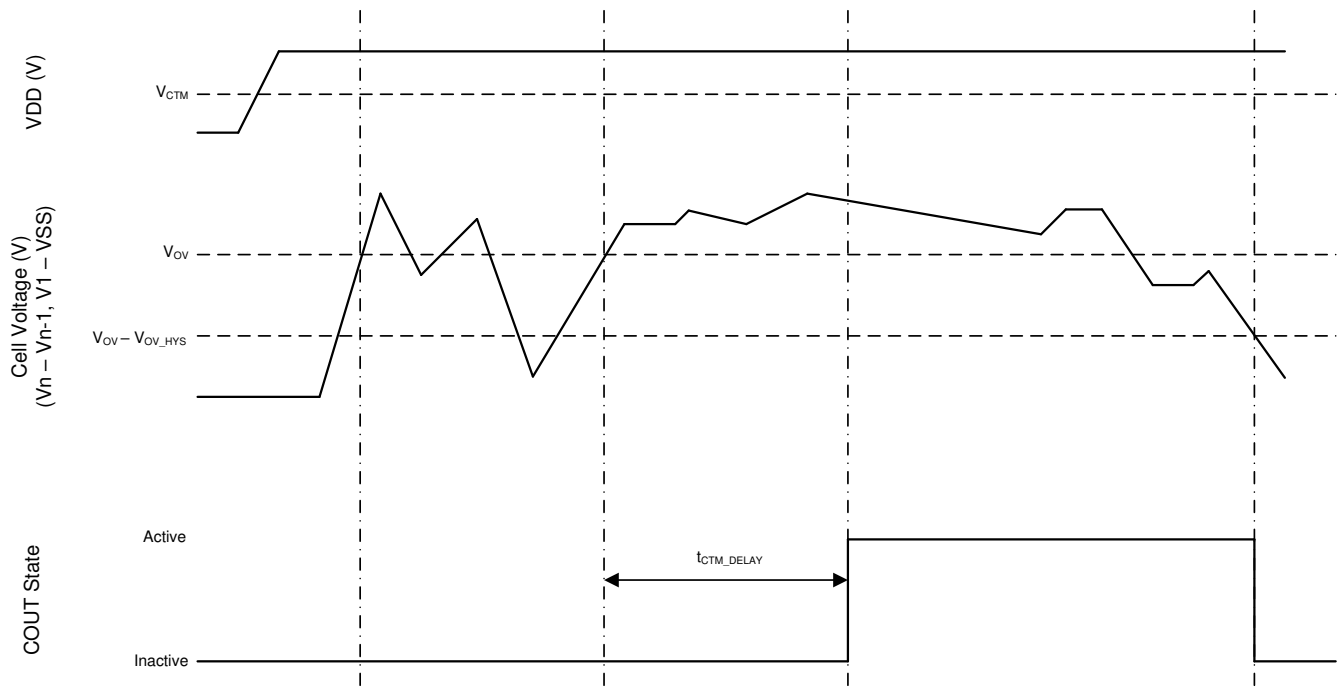

**Figure 7-3. Timing for Customer Test Mode**

## 8 Application and Implementation

### Note

Information in the following applications sections is not part of the TI component specification, and TI does not warrant its accuracy or completeness. TI's customers are responsible for determining suitability of components for their purposes, as well as validating and testing their design implementation to confirm system functionality.

### 8.1 Application Information

Changes to the ranges stated in [Table 8-1](#) will impact the accuracy of the cell measurements.

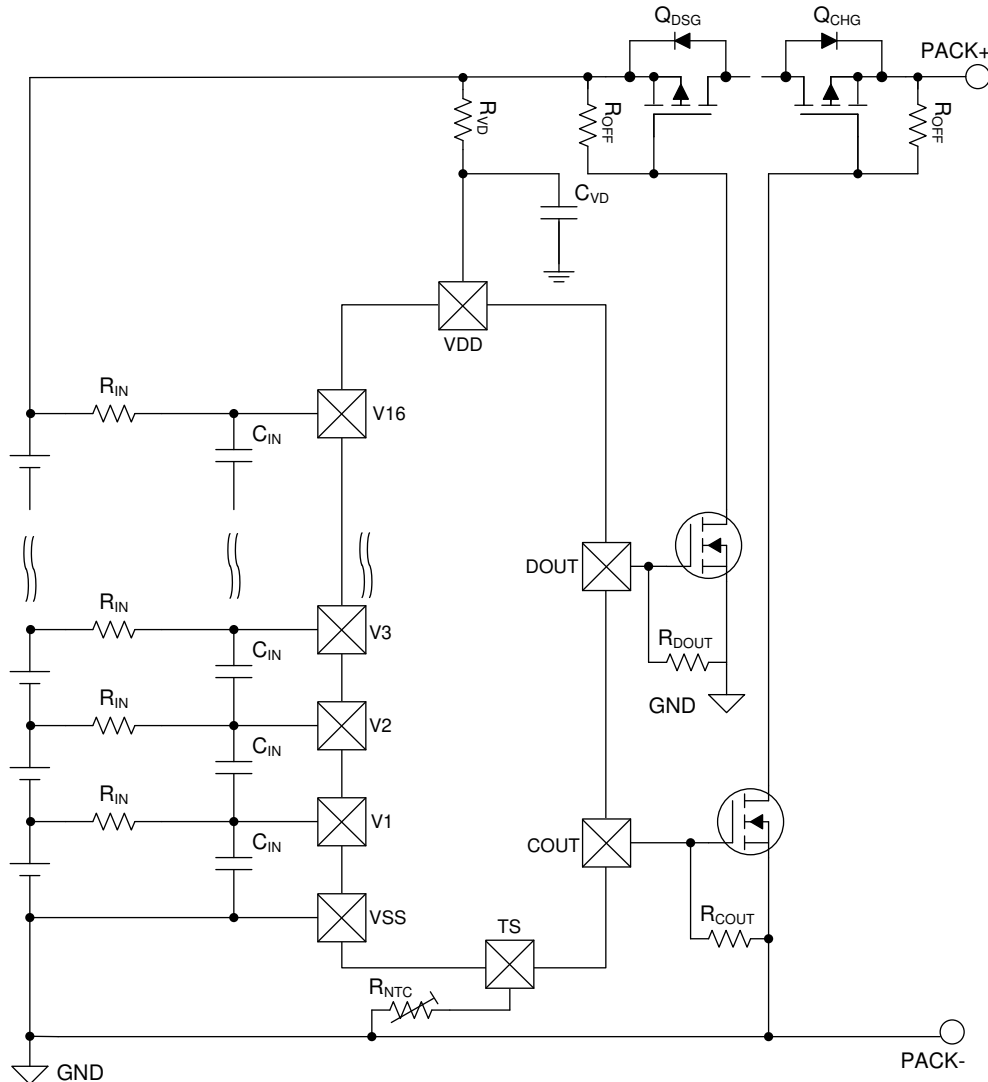

**Figure 8-1. Application Configuration**

#### 8.1.1 Design Requirements

Changes to the ranges stated in [Table 8-1](#) will impact the accuracy of the cell measurements. [Figure 8-1](#) shows each external component.

**Table 8-1. Parameters**

PARAMETER	EXTERNAL COMPONENT	MIN	NOM	MAX	UNIT
Voltage monitor filter resistance	$R_{IN}$	900	1000	1100	$\Omega$
Voltage monitor filter capacitance	$C_{IN}$	0.01		0.1	$\mu\text{F}$
Supply voltage filter resistance	$R_{VD}$	100	300	1K	$\Omega$
Supply voltage filter capacitance	$C_{VD}$	0.05	0.1	1	$\mu\text{F}$

**Note**

The device is calibrated using an  $R_{IN}$  value = 1k $\Omega$ . Using a value other than this recommended value changes the accuracy of the cell voltage measurements and  $V_{OV}$  trigger level.

**8.1.2 Detailed Design Procedure**

Figure 8-2 shows the measurement for current consumption for the product for both VDD and Vx.

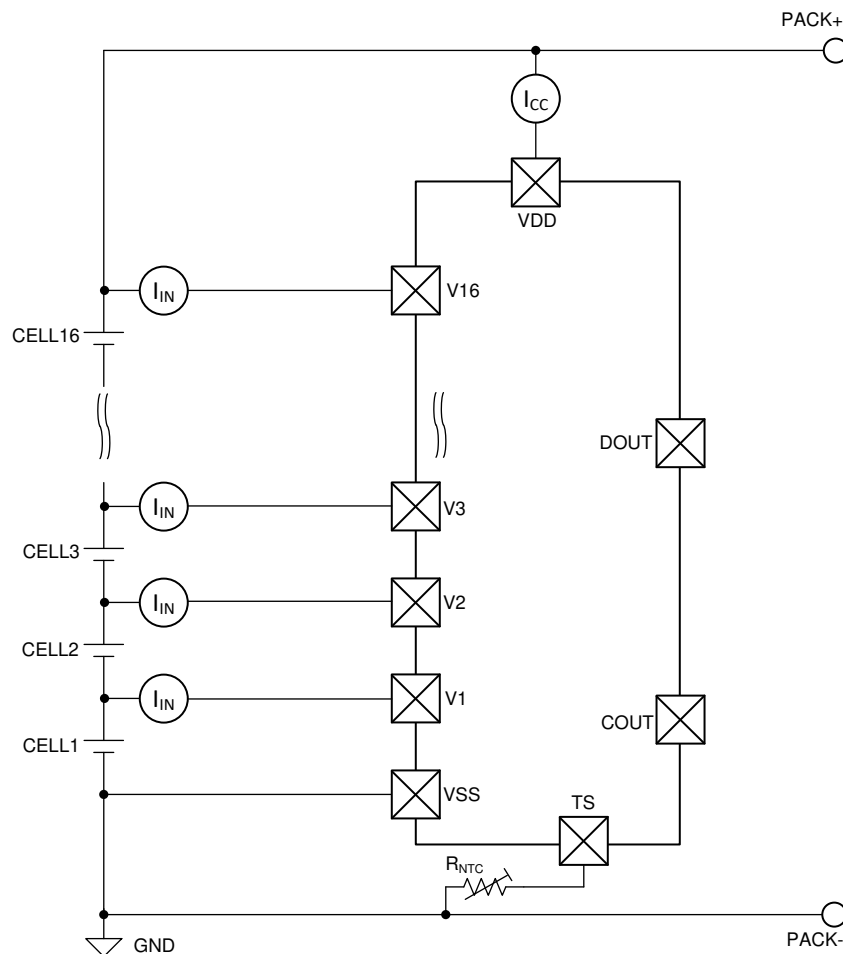

**Figure 8-2. Configuration for IC Current Consumption Test**

**8.1.2.1 Cell Connection Sequence**

The BQ77216xx device can be connected to the array of cells in any order without damaging the device.

During cell attachment, the device could detect a fault if the cells are not connected within a fault detection delay period. If this occurs, then COUT and/or DOUT could transition from inactive to active. Both COUT and DOUT can be tied to VSS or VDD to prevent any change in output state during cell attach.

## 8.2 Systems Example

In this application example, the choice of a FUSE or FETs is required on the COUT and DOUT pins—configured as an active-high drive to 6V outputs.

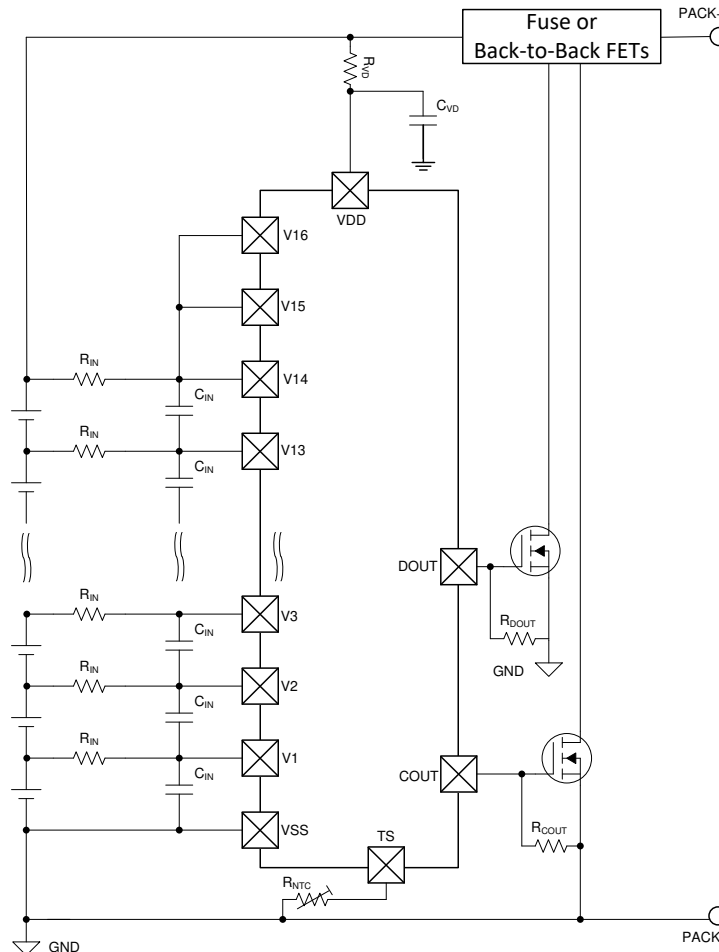

**Figure 8-3. 14-Series Cell Configuration with Active High 6V Option**

When pairing with the BQ769x2 or BQ76940 devices, the top cell must be used. For the BQ77216xx device to drive the CHG and DSG FETs, the active high 6V option is preferred. Its COUT and DOUT are controlling two N-CH FETs to jointly control the CHG and DSG FETs with the monitoring device. For such joint architecture, the open-wire feature of the BQ77216xx device may be affected if the primary protector or monitor device is actively measuring the cells. Care is needed to ensure the  $V_{OW}$  spec of the BQ77216xx device is met or to choose a version of the BQ77216xx device with open wire disabled. When working with a BQ769x2 device, set the LOOP\_SLOW to 0x11 to ensure the BQ77216xx  $V_{OW}$  spec is met.

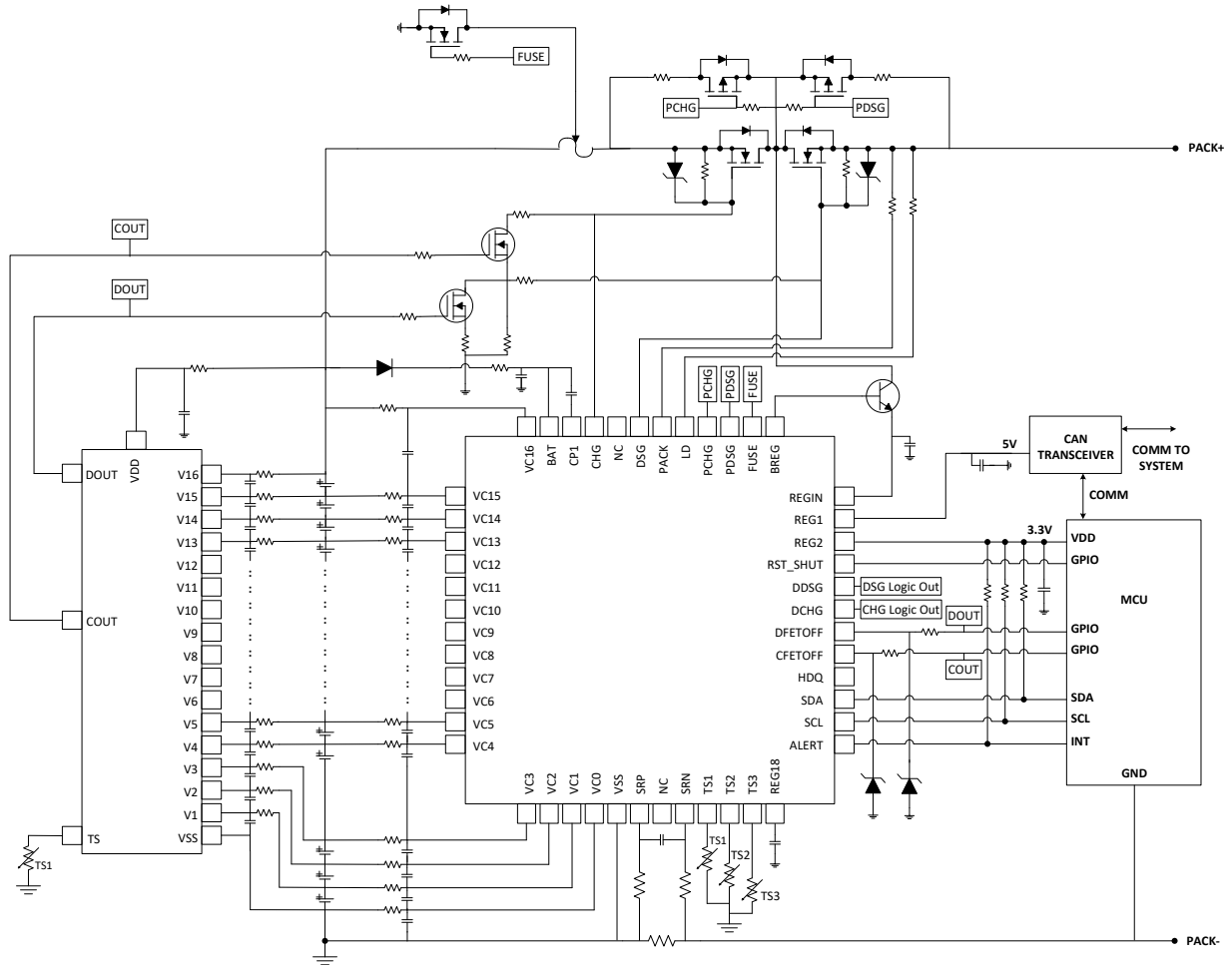

**Figure 8-4. BQ77216 with BQ76952**

## 9 Power Supply Recommendations

The maximum power supply of this device is 85V on VDD.

## 10 Layout

### 10.1 Layout Guidelines

- Ensure the RC filters for the Vn and VDD pins are placed as close as possible to the target terminal.
- The VSS pin should be routed to the CELL– terminal.

### 10.2 Layout Example

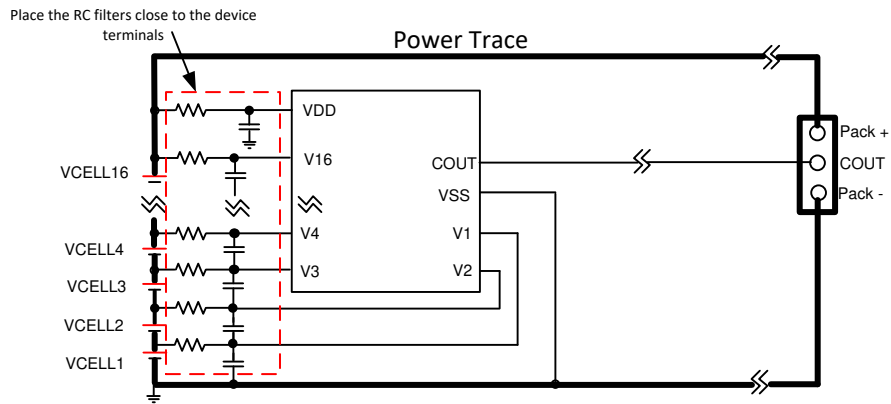

Figure 10-1. Example Layout

## 11 Device and Documentation Support

### 11.1 Third-Party Products Disclaimer

TI'S PUBLICATION OF INFORMATION REGARDING THIRD-PARTY PRODUCTS OR SERVICES DOES NOT CONSTITUTE AN ENDORSEMENT REGARDING THE SUITABILITY OF SUCH PRODUCTS OR SERVICES OR A WARRANTY, REPRESENTATION OR ENDORSEMENT OF SUCH PRODUCTS OR SERVICES, EITHER ALONE OR IN COMBINATION WITH ANY TI PRODUCT OR SERVICE.

### 11.2 Receiving Notification of Documentation Updates

To receive notification of documentation updates, navigate to the device product folder on [ti.com](https://www.ti.com). Click on *Notifications* to register and receive a weekly digest of any product information that has changed. For change details, review the revision history included in any revised document.

### 11.3 Support Resources

[TI E2E™ support forums](#) are an engineer's go-to source for fast, verified answers and design help — straight from the experts. Search existing answers or ask your own question to get the quick design help you need.

Linked content is provided "AS IS" by the respective contributors. They do not constitute TI specifications and do not necessarily reflect TI's views; see TI's [Terms of Use](#).

### 11.4 Trademarks

TI E2E™ is a trademark of Texas Instruments.  
All trademarks are the property of their respective owners.

### 11.5 Electrostatic Discharge Caution



This integrated circuit can be damaged by ESD. Texas Instruments recommends that all integrated circuits be handled with appropriate precautions. Failure to observe proper handling and installation procedures can cause damage.

ESD damage can range from subtle performance degradation to complete device failure. Precision integrated circuits may be more susceptible to damage because very small parametric changes could cause the device not to meet its published specifications.

### 11.6 Glossary

[TI Glossary](#) This glossary lists and explains terms, acronyms, and definitions.

## 12 Revision History

NOTE: Page numbers for previous revisions may differ from page numbers in the current version.

---

### Changes from Revision K (April 2025) to Revision L (September 2025) Page

- Added BQ7721619 to the [Device Comparison Table](#) ..... 3
- 

### Changes from Revision J (November 2023) to Revision K (April 2025) Page

- Updated the [Features](#) ..... 1
  - Updated the [Description](#) ..... 1
  - Updated the [Device Comparison Table](#) ..... 3
- 

### Changes from Revision I (July 2023) to Revision J (November 2023) Page

- Updated the [Device Comparison Table](#) ..... 3
  - Updated the TS pin description..... 5
  - Added the undertemperature protection description..... 11
- 

### Changes from Revision H (March 2023) to Revision I (July 2023) Page

- Updated the [Device Comparison Table](#) ..... 3
- 

### Changes from Revision G (July 2022) to Revision H (March 2023) Page

- Updated the [Device Comparison Table](#) ..... 3
- 

## 13 Mechanical, Packaging, and Orderable Information

The following pages include mechanical, packaging, and orderable information. This information is the most current data available for the designated devices. This data is subject to change without notice and revision of this document. For browser-based versions of this data sheet, refer to the left-hand navigation.

**PACKAGING INFORMATION**

Orderable part number	Status (1)	Material type (2)	Package   Pins	Package qty   Carrier	RoHS (3)	Lead finish/ Ball material (4)	MSL rating/ Peak reflow (5)	Op temp (°C)	Part marking (6)
<a href="#">BQ7721600PWR</a>	Active	Production	TSSOP (PW)   24	2000   LARGE T&R	Yes	NIPDAU	Level-2-260C-1 YEAR	-40 to 85	BQ7721600
BQ7721600PWR.A	Active	Production	TSSOP (PW)   24	2000   LARGE T&R	Yes	NIPDAU	Level-2-260C-1 YEAR	-40 to 85	BQ7721600
<a href="#">BQ7721602PWR</a>	Active	Production	TSSOP (PW)   24	2000   LARGE T&R	Yes	NIPDAU	Level-2-260C-1 YEAR	-40 to 85	BQ7721602
BQ7721602PWR.A	Active	Production	TSSOP (PW)   24	2000   LARGE T&R	Yes	NIPDAU	Level-2-260C-1 YEAR	-40 to 85	BQ7721602
<a href="#">BQ7721603PWR</a>	Active	Production	TSSOP (PW)   24	2000   LARGE T&R	Yes	NIPDAU	Level-2-260C-1 YEAR	-40 to 85	BQ7721603
BQ7721603PWR.A	Active	Production	TSSOP (PW)   24	2000   LARGE T&R	Yes	NIPDAU	Level-2-260C-1 YEAR	-40 to 85	BQ7721603
<a href="#">BQ7721605PWR</a>	Active	Production	TSSOP (PW)   24	2000   LARGE T&R	Yes	NIPDAU	Level-2-260C-1 YEAR	-40 to 110	BQ7721605
BQ7721605PWR.A	Active	Production	TSSOP (PW)   24	2000   LARGE T&R	Yes	NIPDAU	Level-2-260C-1 YEAR	-40 to 110	BQ7721605
<a href="#">BQ7721606PWR</a>	Active	Production	TSSOP (PW)   24	2000   LARGE T&R	Yes	NIPDAU	Level-2-260C-1 YEAR	-40 to 110	BQ7721606
BQ7721606PWR.A	Active	Production	TSSOP (PW)   24	2000   LARGE T&R	Yes	NIPDAU	Level-2-260C-1 YEAR	-40 to 110	BQ7721606
<a href="#">BQ7721607PWR</a>	Active	Production	TSSOP (PW)   24	2000   LARGE T&R	Yes	NIPDAU	Level-2-260C-1 YEAR	-40 to 110	BQ7721607
BQ7721607PWR.A	Active	Production	TSSOP (PW)   24	2000   LARGE T&R	Yes	NIPDAU	Level-2-260C-1 YEAR	-40 to 110	BQ7721607
<a href="#">BQ7721609PWR</a>	Active	Production	TSSOP (PW)   24	2000   LARGE T&R	Yes	NIPDAU	Level-2-260C-1 YEAR	-40 to 110	BQ7721609
BQ7721609PWR.A	Active	Production	TSSOP (PW)   24	2000   LARGE T&R	Yes	NIPDAU	Level-2-260C-1 YEAR	-40 to 110	BQ7721609
<a href="#">BQ7721610PWR</a>	Active	Production	TSSOP (PW)   24	2000   LARGE T&R	Yes	NIPDAU	Level-2-260C-1 YEAR	-40 to 110	BQ7721610
BQ7721610PWR.A	Active	Production	TSSOP (PW)   24	2000   LARGE T&R	Yes	NIPDAU	Level-2-260C-1 YEAR	-40 to 110	BQ7721610
<a href="#">BQ7721611PWR</a>	Active	Production	TSSOP (PW)   24	2000   LARGE T&R	Yes	NIPDAU	Level-2-260C-1 YEAR	-40 to 110	BQ7721611
BQ7721611PWR.A	Active	Production	TSSOP (PW)   24	2000   LARGE T&R	Yes	NIPDAU	Level-2-260C-1 YEAR	-40 to 110	BQ7721611
<a href="#">BQ7721612PWR</a>	Active	Production	TSSOP (PW)   24	2000   LARGE T&R	Yes	NIPDAU	Level-2-260C-1 YEAR	-40 to 110	BQ7721612
BQ7721612PWR.A	Active	Production	TSSOP (PW)   24	2000   LARGE T&R	Yes	NIPDAU	Level-2-260C-1 YEAR	-40 to 110	BQ7721612
<a href="#">BQ7721613PWR</a>	Active	Production	TSSOP (PW)   24	2000   LARGE T&R	Yes	NIPDAU	Level-2-260C-1 YEAR	-40 to 110	BQ7721613
BQ7721613PWR.A	Active	Production	TSSOP (PW)   24	2000   LARGE T&R	Yes	NIPDAU	Level-2-260C-1 YEAR	-40 to 110	BQ7721613
<a href="#">BQ7721614PWR</a>	Active	Production	TSSOP (PW)   24	2000   LARGE T&R	Yes	NIPDAU	Level-2-260C-1 YEAR	-40 to 110	BQ7721614
BQ7721614PWR.A	Active	Production	TSSOP (PW)   24	2000   LARGE T&R	Yes	NIPDAU	Level-2-260C-1 YEAR	-40 to 110	BQ7721614
<a href="#">BQ7721615PWR</a>	Active	Production	TSSOP (PW)   24	2000   LARGE T&R	Yes	NIPDAU	Level-2-260C-1 YEAR	-40 to 110	BQ7721615
BQ7721615PWR.A	Active	Production	TSSOP (PW)   24	2000   LARGE T&R	Yes	NIPDAU	Level-2-260C-1 YEAR	-40 to 110	BQ7721615
<a href="#">BQ7721616PWR</a>	Active	Production	TSSOP (PW)   24	2000   LARGE T&R	Yes	NIPDAU	Level-2-260C-1 YEAR	-40 to 110	BQ7721616
BQ7721616PWR.A	Active	Production	TSSOP (PW)   24	2000   LARGE T&R	Yes	NIPDAU	Level-2-260C-1 YEAR	-40 to 110	BQ7721616
<a href="#">BQ7721617PWR</a>	Active	Production	TSSOP (PW)   24	2000   LARGE T&R	Yes	NIPDAU	Level-2-260C-1 YEAR	-40 to 110	BQ7721617

Orderable part number	Status (1)	Material type (2)	Package   Pins	Package qty   Carrier	RoHS (3)	Lead finish/ Ball material (4)	MSL rating/ Peak reflow (5)	Op temp (°C)	Part marking (6)
BQ7721618PWR	Active	Production	TSSOP (PW)   24	2000   LARGE T&R	Yes	NIPDAU	Level-2-260C-1 YEAR	-40 to 110	BQ7721618
BQ7721619PWR	Active	Production	TSSOP (PW)   24	2000   LARGE T&R	Yes	NIPDAU	Level-2-260C-1 YEAR	-40 to 110	BQ7721619
BQ7721620PWR	Active	Production	TSSOP (PW)   24	2000   LARGE T&R	Yes	NIPDAU	Level-2-260C-1 YEAR	-40 to 110	BQ7721620

(1) **Status:** For more details on status, see our [product life cycle](#).

(2) **Material type:** When designated, preproduction parts are prototypes/experimental devices, and are not yet approved or released for full production. Testing and final process, including without limitation quality assurance, reliability performance testing, and/or process qualification, may not yet be complete, and this item is subject to further changes or possible discontinuation. If available for ordering, purchases will be subject to an additional waiver at checkout, and are intended for early internal evaluation purposes only. These items are sold without warranties of any kind.

(3) **RoHS values:** Yes, No, RoHS Exempt. See the [TI RoHS Statement](#) for additional information and value definition.

(4) **Lead finish/Ball material:** Parts may have multiple material finish options. Finish options are separated by a vertical ruled line. Lead finish/Ball material values may wrap to two lines if the finish value exceeds the maximum column width.

(5) **MSL rating/Peak reflow:** The moisture sensitivity level ratings and peak solder (reflow) temperatures. In the event that a part has multiple moisture sensitivity ratings, only the lowest level per JEDEC standards is shown. Refer to the shipping label for the actual reflow temperature that will be used to mount the part to the printed circuit board.

(6) **Part marking:** There may be an additional marking, which relates to the logo, the lot trace code information, or the environmental category of the part.

Multiple part markings will be inside parentheses. Only one part marking contained in parentheses and separated by a "-" will appear on a part. If a line is indented then it is a continuation of the previous line and the two combined represent the entire part marking for that device.

**Important Information and Disclaimer:** The information provided on this page represents TI's knowledge and belief as of the date that it is provided. TI bases its knowledge and belief on information provided by third parties, and makes no representation or warranty as to the accuracy of such information. Efforts are underway to better integrate information from third parties. TI has taken and continues to take reasonable steps to provide representative and accurate information but may not have conducted destructive testing or chemical analysis on incoming materials and chemicals. TI and TI suppliers consider certain information to be proprietary, and thus CAS numbers and other limited information may not be available for release.

In no event shall TI's liability arising out of such information exceed the total purchase price of the TI part(s) at issue in this document sold by TI to Customer on an annual basis.

**TAPE AND REEL INFORMATION**

**QUADRANT ASSIGNMENTS FOR PIN 1 ORIENTATION IN TAPE**

\*All dimensions are nominal

Device	Package Type	Package Drawing	Pins	SPQ	Reel Diameter (mm)	Reel Width W1 (mm)	A0 (mm)	B0 (mm)	K0 (mm)	P1 (mm)	W (mm)	Pin1 Quadrant
BQ7721600PWR	TSSOP	PW	24	2000	330.0	16.4	6.95	8.3	1.6	8.0	16.0	Q1
BQ7721602PWR	TSSOP	PW	24	2000	330.0	16.4	6.95	8.3	1.6	8.0	16.0	Q1
BQ7721603PWR	TSSOP	PW	24	2000	330.0	16.4	6.95	8.3	1.6	8.0	16.0	Q1
BQ7721605PWR	TSSOP	PW	24	2000	330.0	16.4	6.95	8.3	1.6	8.0	16.0	Q1
BQ7721606PWR	TSSOP	PW	24	2000	330.0	16.4	6.95	8.3	1.6	8.0	16.0	Q1
BQ7721607PWR	TSSOP	PW	24	2000	330.0	16.4	6.95	8.3	1.6	8.0	16.0	Q1
BQ7721609PWR	TSSOP	PW	24	2000	330.0	16.4	6.95	8.3	1.6	8.0	16.0	Q1
BQ7721610PWR	TSSOP	PW	24	2000	330.0	16.4	6.95	8.3	1.6	8.0	16.0	Q1
BQ7721611PWR	TSSOP	PW	24	2000	330.0	16.4	6.95	8.3	1.6	8.0	16.0	Q1
BQ7721612PWR	TSSOP	PW	24	2000	330.0	16.4	6.95	8.3	1.6	8.0	16.0	Q1
BQ7721613PWR	TSSOP	PW	24	2000	330.0	16.4	6.95	8.3	1.6	8.0	16.0	Q1
BQ7721614PWR	TSSOP	PW	24	2000	330.0	16.4	6.95	8.3	1.6	8.0	16.0	Q1
BQ7721615PWR	TSSOP	PW	24	2000	330.0	16.4	6.95	8.3	1.6	8.0	16.0	Q1
BQ7721616PWR	TSSOP	PW	24	2000	330.0	16.4	6.95	8.3	1.6	8.0	16.0	Q1
BQ7721617PWR	TSSOP	PW	24	2000	330.0	16.4	6.95	8.3	1.6	8.0	16.0	Q1
BQ7721618PWR	TSSOP	PW	24	2000	330.0	16.4	6.95	8.3	1.6	8.0	16.0	Q1

Device	Package Type	Package Drawing	Pins	SPQ	Reel Diameter (mm)	Reel Width W1 (mm)	A0 (mm)	B0 (mm)	K0 (mm)	P1 (mm)	W (mm)	Pin1 Quadrant
BQ7721619PWR	TSSOP	PW	24	2000	330.0	16.4	6.95	8.3	1.6	8.0	16.0	Q1
BQ7721620PWR	TSSOP	PW	24	2000	330.0	16.4	6.95	8.3	1.6	8.0	16.0	Q1

**TAPE AND REEL BOX DIMENSIONS**

\*All dimensions are nominal

Device	Package Type	Package Drawing	Pins	SPQ	Length (mm)	Width (mm)	Height (mm)
BQ7721600PWR	TSSOP	PW	24	2000	353.0	353.0	32.0
BQ7721602PWR	TSSOP	PW	24	2000	353.0	353.0	32.0
BQ7721603PWR	TSSOP	PW	24	2000	353.0	353.0	32.0
BQ7721605PWR	TSSOP	PW	24	2000	353.0	353.0	32.0
BQ7721606PWR	TSSOP	PW	24	2000	353.0	353.0	32.0
BQ7721607PWR	TSSOP	PW	24	2000	353.0	353.0	32.0
BQ7721609PWR	TSSOP	PW	24	2000	353.0	353.0	32.0
BQ7721610PWR	TSSOP	PW	24	2000	353.0	353.0	32.0
BQ7721611PWR	TSSOP	PW	24	2000	353.0	353.0	32.0
BQ7721612PWR	TSSOP	PW	24	2000	353.0	353.0	32.0
BQ7721613PWR	TSSOP	PW	24	2000	353.0	353.0	32.0
BQ7721614PWR	TSSOP	PW	24	2000	353.0	353.0	32.0
BQ7721615PWR	TSSOP	PW	24	2000	353.0	353.0	32.0
BQ7721616PWR	TSSOP	PW	24	2000	353.0	353.0	32.0
BQ7721617PWR	TSSOP	PW	24	2000	353.0	353.0	32.0
BQ7721618PWR	TSSOP	PW	24	2000	353.0	353.0	32.0
BQ7721619PWR	TSSOP	PW	24	2000	353.0	353.0	32.0
BQ7721620PWR	TSSOP	PW	24	2000	353.0	353.0	32.0

PW0024A

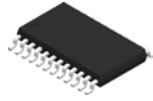

# PACKAGE OUTLINE

## TSSOP - 1.2 mm max height

SMALL OUTLINE PACKAGE

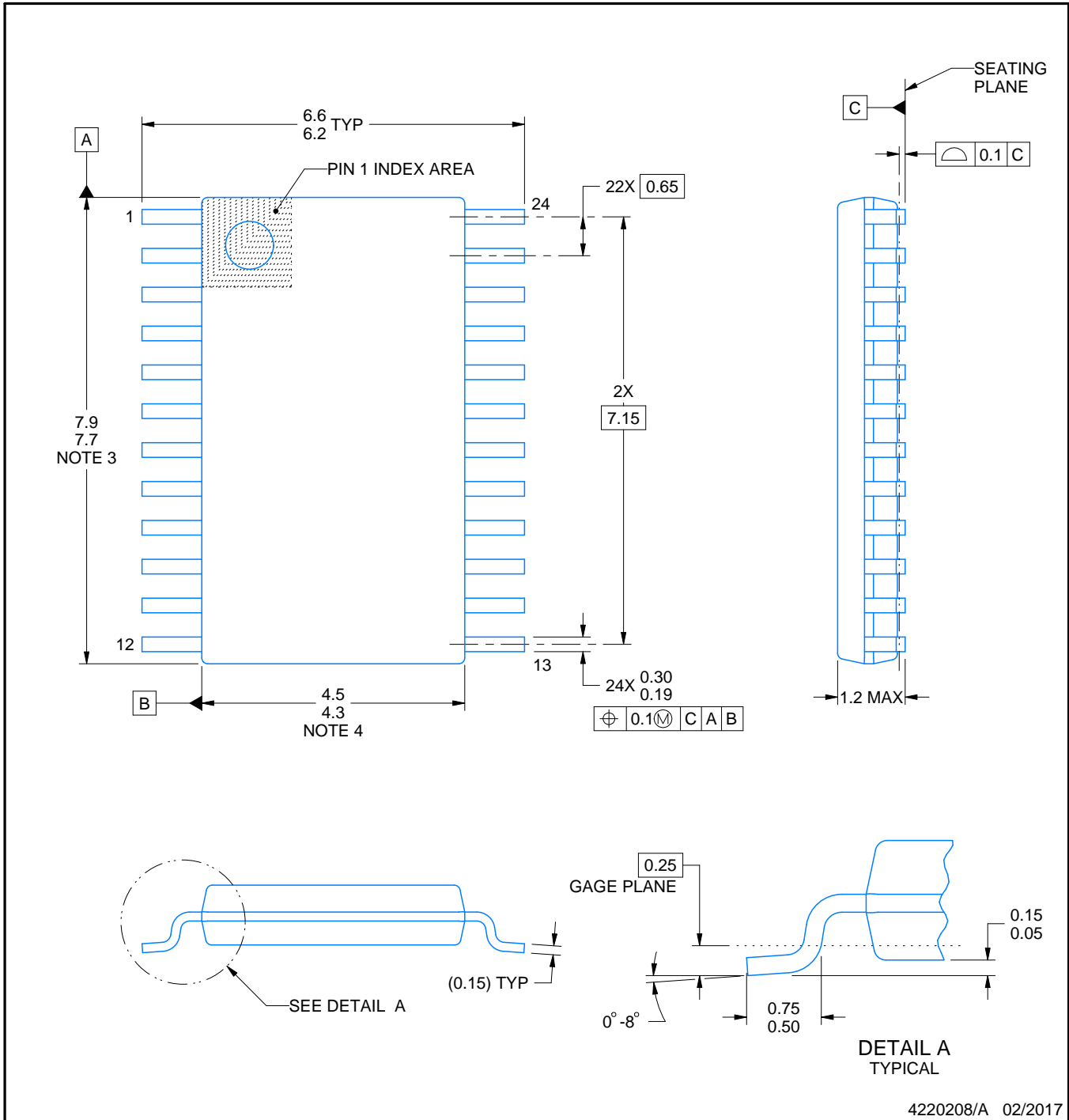

4220208/A 02/2017

NOTES:

1. All linear dimensions are in millimeters. Any dimensions in parenthesis are for reference only. Dimensioning and tolerancing per ASME Y14.5M.
2. This drawing is subject to change without notice.
3. This dimension does not include mold flash, protrusions, or gate burrs. Mold flash, protrusions, or gate burrs shall not exceed 0.15 mm per side.
4. This dimension does not include interlead flash. Interlead flash shall not exceed 0.25 mm per side.
5. Reference JEDEC registration MO-153.

# EXAMPLE BOARD LAYOUT

PW0024A

TSSOP - 1.2 mm max height

SMALL OUTLINE PACKAGE

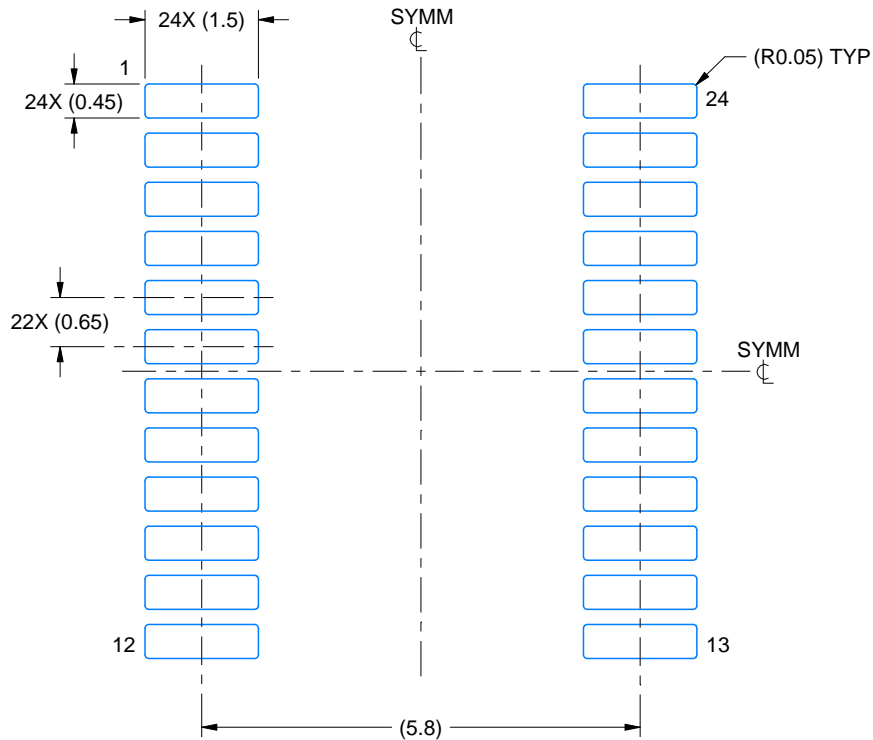

LAND PATTERN EXAMPLE  
EXPOSED METAL SHOWN  
SCALE: 10X

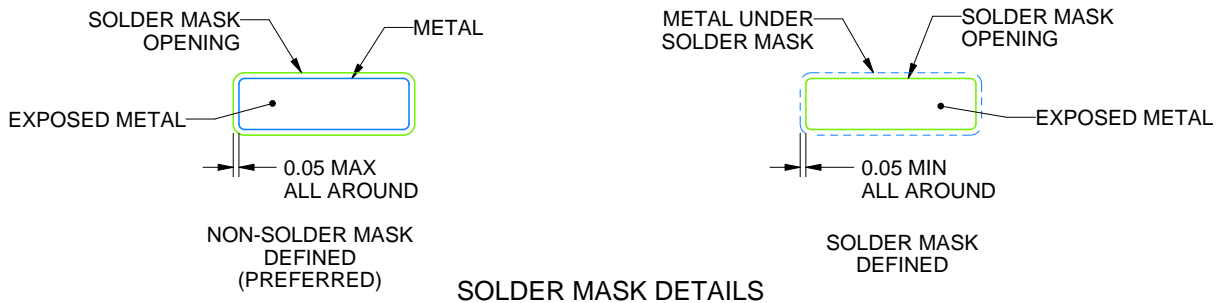

SOLDER MASK DETAILS

4220208/A 02/2017

NOTES: (continued)

- 6. Publication IPC-7351 may have alternate designs.
- 7. Solder mask tolerances between and around signal pads can vary based on board fabrication site.

# EXAMPLE STENCIL DESIGN

PW0024A

TSSOP - 1.2 mm max height

SMALL OUTLINE PACKAGE

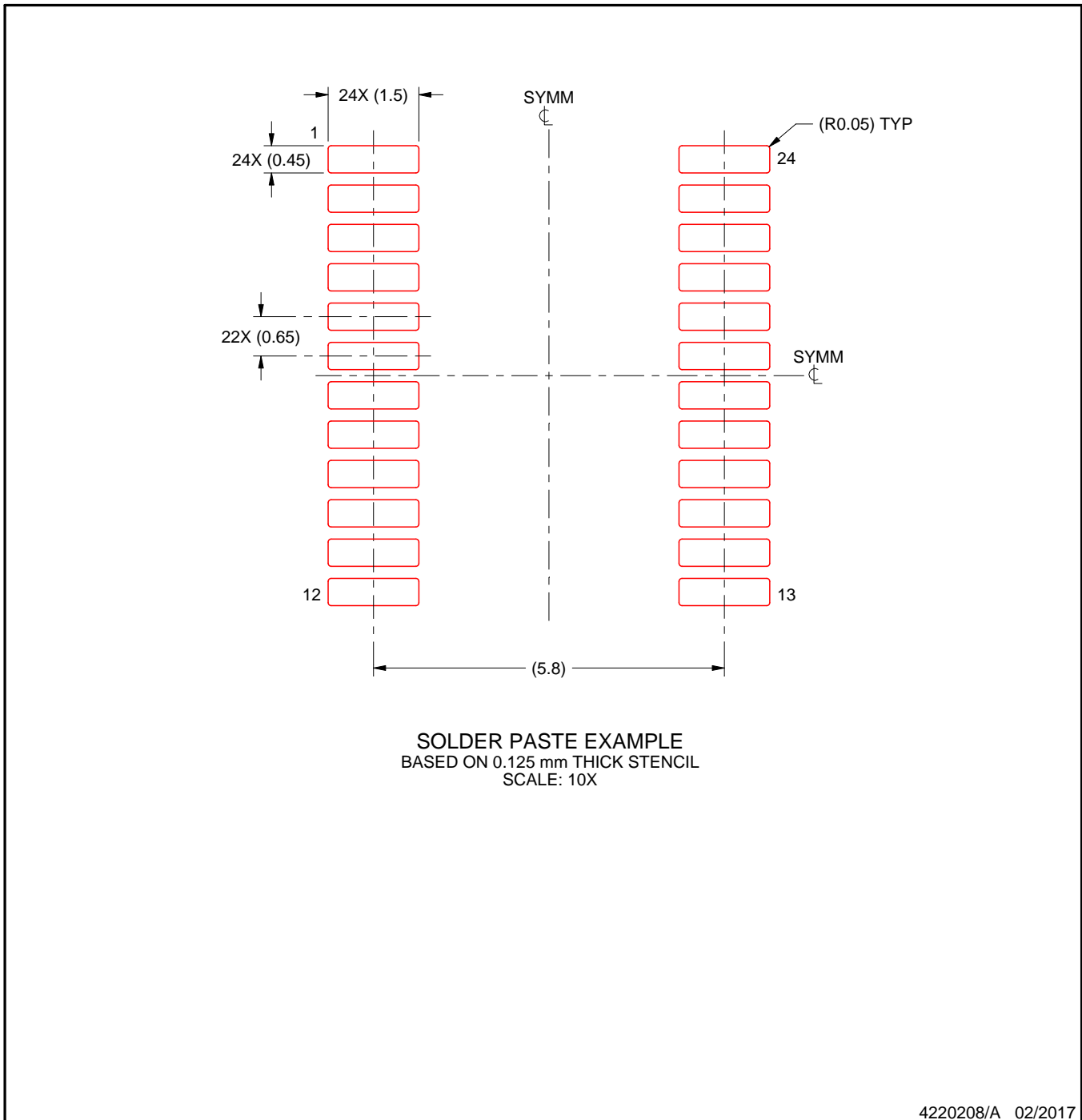

NOTES: (continued)

8. Laser cutting apertures with trapezoidal walls and rounded corners may offer better paste release. IPC-7525 may have alternate design recommendations.
9. Board assembly site may have different recommendations for stencil design.

## IMPORTANT NOTICE AND DISCLAIMER

TI PROVIDES TECHNICAL AND RELIABILITY DATA (INCLUDING DATASHEETS), DESIGN RESOURCES (INCLUDING REFERENCE DESIGNS), APPLICATION OR OTHER DESIGN ADVICE, WEB TOOLS, SAFETY INFORMATION, AND OTHER RESOURCES "AS IS" AND WITH ALL FAULTS, AND DISCLAIMS ALL WARRANTIES, EXPRESS AND IMPLIED, INCLUDING WITHOUT LIMITATION ANY IMPLIED WARRANTIES OF MERCHANTABILITY, FITNESS FOR A PARTICULAR PURPOSE OR NON-INFRINGEMENT OF THIRD PARTY INTELLECTUAL PROPERTY RIGHTS.

These resources are intended for skilled developers designing with TI products. You are solely responsible for (1) selecting the appropriate TI products for your application, (2) designing, validating and testing your application, and (3) ensuring your application meets applicable standards, and any other safety, security, regulatory or other requirements.

These resources are subject to change without notice. TI grants you permission to use these resources only for development of an application that uses the TI products described in the resource. Other reproduction and display of these resources is prohibited. No license is granted to any other TI intellectual property right or to any third party intellectual property right. TI disclaims responsibility for, and you fully indemnify TI and its representatives against any claims, damages, costs, losses, and liabilities arising out of your use of these resources.

TI's products are provided subject to [TI's Terms of Sale](#), [TI's General Quality Guidelines](#), or other applicable terms available either on [ti.com](#) or provided in conjunction with such TI products. TI's provision of these resources does not expand or otherwise alter TI's applicable warranties or warranty disclaimers for TI products. Unless TI explicitly designates a product as custom or customer-specified, TI products are standard, catalog, general purpose devices.

TI objects to and rejects any additional or different terms you may propose.

Copyright © 2025, Texas Instruments Incorporated

Last updated 10/2025

## Looking for pricing, stock, or lifecycle information?

Click below to explore more details on WIN SOURCE:

 [View BQ7721607PWR](#) on WIN SOURCE

 [Texas Instruments](#) Information

## Optimize Your Supply Chain with WIN SOURCE Solutions

-  Global Sourcing Solution
-  Obsolete Management
-  Cost Control Management
-  Shortage Management
-  Alternative Solution
-  Excess Inventory Management