



**THE DATASHEET OF
JR1AF-TM-DC6V**



NAIS

SLIM TYPE POWER RELAYS

JR-RELAYS

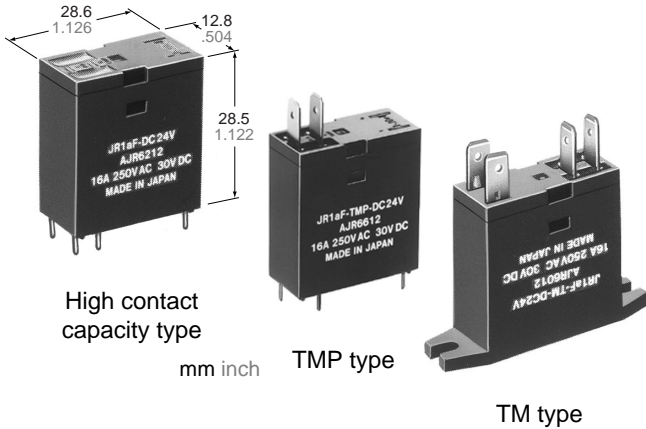

FEATURES

- AC coil types and high capacity (16 A) types
- Wide insulation distance: 8 mm .315 inch between coil and contact
- High dielectric withstanding for transient protection: JR can withstand 10,000 V surge in μ s between coil and contact.
- High inrush current capability: 1 Form A: 111 A inrush (TV-5),
- Slim package for tandem mounting: Header area is 28.6 mm \times 12.8 mm 1.126 \times .504 inch
- Molded materials: all 94 V-0
- "TM" and "TMP" types available
- TÜV also approved

SPECIFICATIONS

Contact

		AC coil type	High capacity type
Arrangement		1 Form A	
Initial contact resistance max. (By voltage drop 6 V DC 1 A)		30 m Ω	
Contact material		Silver alloy	
Rating (resistive)	Nominal switching capacity	10 A 250 V AC 10 A 30 V DC	16 A 250 V AC 16 A 30 V DC
	Maximum switching power	2,500 VA, 300 W	4,000 VA, 480 W
	Maximum switching voltage	250 V AC, 30 V DC	250 V AC, 30 V DC
	Maximum switching current	10 A	16 A
Expected life (min. operations)	Mechanical (180 cpm)	5 \times 10 ⁶	
	Electrical (resistive) (20 cpm)	16 A 250 V AC	10 ⁵
	10 A 250 V AC	10 ⁵	—

Coil

	1.1 VA/0.9 VA (at 50Hz/60Hz)	530mW
Nominal operating power		

Remarks

- * Specifications will vary with foreign standards certification ratings.
- *1 Detection current: 10mA
- *2 Wave is standard shock voltage of $\pm 1.2 \times 50\mu$ s according to JEC-212-1981
- *3 With nominal coil voltage and at maximum switching current
- *4 Half-wave pulse of sine wave: 11ms; detection time: 10 μ s
- *5 Half-wave pulse of sine wave: 6ms
- *6 Detection time: 10 μ s
- *7 Refer to 5. Conditions for operation, transport and storage mentioned in AMBIENT ENVIRONMENT (Page 24).

Characteristics

		AC coil type	High capacity type
Maximum operating speed		20 cpm	
Initial insulation resistance		Min. 1,000 M Ω at 500 V DC	
Initial breakdown voltage*1	Between open contacts	1,000 Vrms for 1 min.	
	Between contacts and coil	5,000 Vrms for 1 min.	
Initial surge voltage between coil and contact*2		Min. 10,000 V	
Operate time (at nominal voltage)(at 20°C)		Approx. 10 ms	
Release time (without diode) (at nominal voltage)(at 20°C)		Approx. 6 ms	Approx. 2 ms
Temperature rise*3 (at nominal voltage)		Max. 60°C (10 A, at 20°C)	Max. 45°C (16 A, at 20°C)
Shock resistance	Functional*4	Min. 98 m/s ² {10 G}	
	Destructive*5	Min. 980 m/s ² {100 G}	
Vibration resistance	Functional*6	88.2 m/s ² {9 G}, 10 to 55 Hz at double amplitude of 1.5 mm	
	Destructive	117.6 m/s ² {12 G}, 10 to 55 Hz at double amplitude of 2.0 mm	
Conditions for operation, transport and storage*7 (Not freezing and condensing at low temperature)	Ambient temp.	-50°C to +55°C -58°F to +131°F	-50°C to +70°C -58°F to +158°F
	Humidity	5 to 85% R.H.	
Unit weight		Approx. 20 g .71 oz	

TYPICAL APPLICATIONS ORDERING INFORMATION

- Microwave ovens
- Refrigerators
- Copiers
- Facsimiles
- Air conditioners
- Stereo equipment
- TV sets
- Vending machines
- Temperature controllers

Ex. JR 1a — TM — DC12V

Contact arrangement	Mounting method	Coil voltage
1a: 1 Form A	TM: Top mounting	AC 115 V
1aF: High contact capacity (1 Form A)	Nil: PCB terminal TM: Top mounting TMP: Solder and PC terminal	DC 5, 6, 12, 24, 48 V

- Notes: 1. For UL/CSA recognized types, add suffix UL/CSA.
2. Standard packing: Carton: 100 pcs. Case: 500 pcs.
3. 18 V DC type are also available. Please consult us for details.

TYPES

High contact capacity types

1. PC board terminals (Double terminal layout)

Contact arrangement	Coil voltage	Part No.
1a	5 V DC	JR1aF-DC5V
	6 V DC	JR1aF-DC6V
	12 V DC	JR1aF-DC12V
	24 V DC	JR1aF-DC24V
	48 V DC	JR1aF-DC48V

2. "TMP" type

Contact arrangement	Coil voltage	Part No.
1a	5 V DC	JR1aF-TMP-DC5V
	6 V DC	JR1aF-TMP-DC6V
	12 V DC	JR1aF-TMP-DC12V
	24 V DC	JR1aF-TMP-DC24V
	48 V DC	JR1aF-TMP-DC48V

3. "TM" type

Contact arrangement	Coil voltage	Part No.
1a	5 V DC	JR1aF-TM-DC5V
	6 V DC	JR1aF-TM-DC6V
	12 V DC	JR1aF-TM-DC12V
	24 V DC	JR1aF-TM-DC24V
	48 V DC	JR1aF-TM-DC48V

AC coil type

1a	115 V AC	JR1a-TM-AC115V
----	----------	----------------

(Notes) 1. For UL/CSA recognized types, add suffix UL/CSA.
 2. Standard packing Carton: 100 pcs., Case 500 pcs.

UL CSA TV rating types available

Type	UL	CSA
JR1a AC coil type	TV-5	TV-5
JR1aF high capacity type	TV-5	TV-5

COIL DATA (at 20°C 68°F)

Contact arrangement	Nominal voltage	Pick-up voltage, (max.) (Initial)	Drop-out voltage, (min.) (Initial)	Coil resistance, Ω (±10%)	Nominal operating current, mA (±10%)	Nominal operating power, mW	Maximum allowable voltage, (at 70°C 158°F)
1 Form A	5 V DC	4.0 V DC	0.5 V DC	47	106	530	5.5 V DC
	6 V DC	4.8 V DC	0.6 V DC	68	88	530	6.6 V DC
	12 V DC	9.6 V DC	1.2 V DC	270	44	530	13.2 V DC
	24 V DC	19.2 V DC	2.4 V DC	1,100	22	530	26.4 V DC
	48 V DC	38.4 V DC	4.8 V DC	4,350	11	530	52.8 V DC
	*115 V AC	92 V AC	34.5 V AC	—	7.8/9.1 (60 Hz)/(50 Hz)	0.9/1.1 VA (60 Hz)/(50 Hz)	126.5V AC (at 20°C 68°F)

Note: Coil resistance varies ±10% for less than 1,000 Ω coil and ±15% for more than 1,000 Ω.
 For each ±1°C change in ambient temperature, coil resistance varies ±0.4%.
 *AC 100 V coil is available only for JR1a-TM type.

DIMENSIONS

mm inch

• JR1aF (DC)

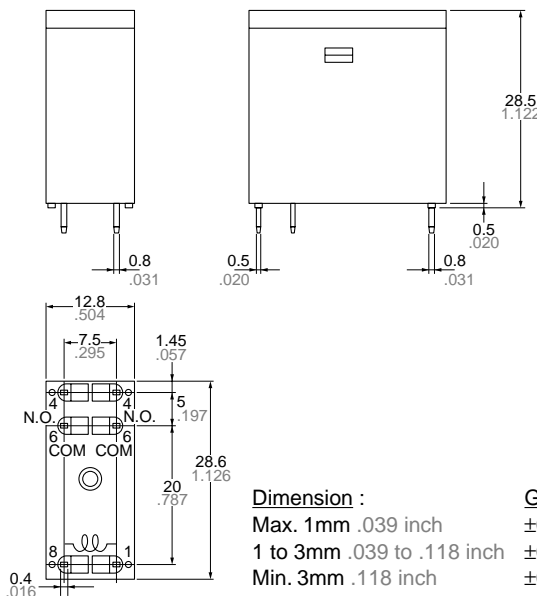

PC board pattern (Copper-side view)

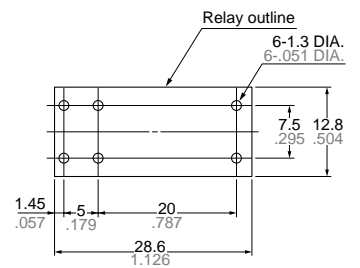

Tolerance: ±0.1 ±.004

Schematic (BOTTOM VIEW)

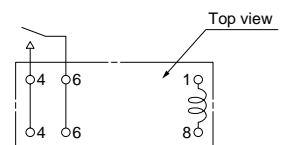

• JR1aF-TMP (DC)

mm inch

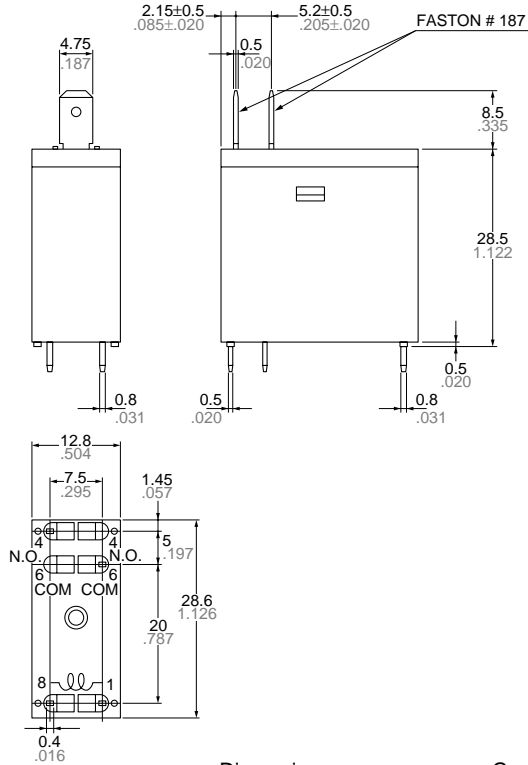

PC board pattern (Copper-side view)

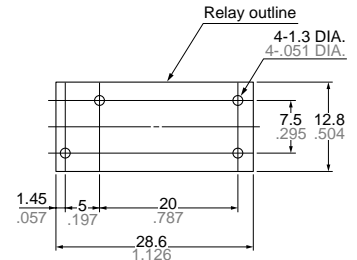

Tolerance: ±0.1 ±.004

Schematic (BOTTOM VIEW)

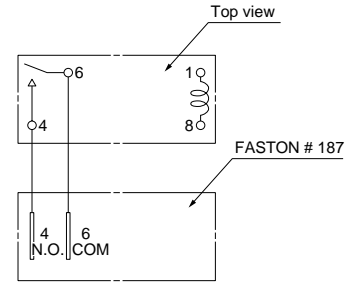

Dimension :	General tolerance
Max. 1mm .039 inch	±0.1 ±.004
1 to 3mm .039 to .118 inch	±0.2 ±.008
Min. 3mm .118 inch	±0.3 ±.012

• JR1aF-TM (DC) / JR1a-TM (AC)

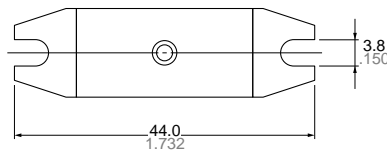

Panel cutout

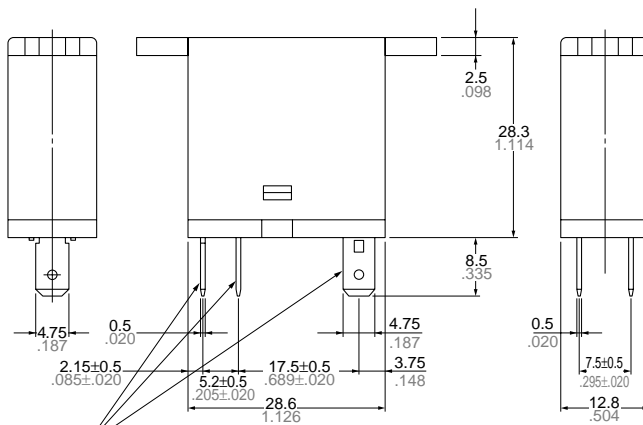
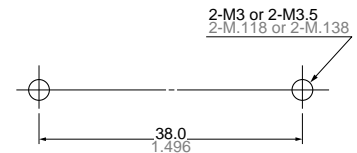

Schematic (BOTTOM VIEW)

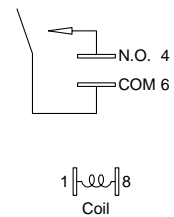

Dimension :	General tolerance
Max. 1mm .039 inch	±0.1 ±.004
1 to 3mm .039 to .118 inch	±0.2 ±.008
Min. 3mm .118 inch	±0.3 ±.012

* JR1a-TM-AC 100 V is not high contact capacity version but has the same dimensions as JR1aF-TM.

REFERENCE DATA

1. Coil temperature rise

Sample: JR1aF-TM-DC24V

Measurement at coil inside and contact portion

Ambient temperature: 22°C to 25°C 72°F to 77°F

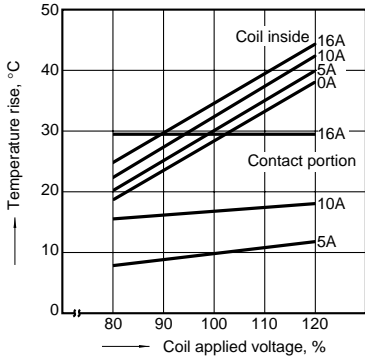

2. Operate & release time

Sample: JR1aF-TM-DC24V

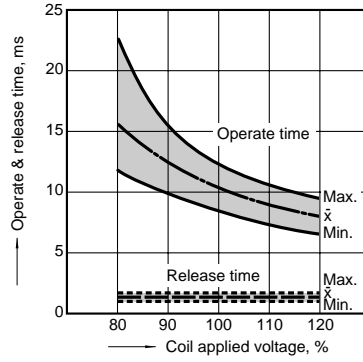

NOTES



"TM" and "TMP" types of high contact capacity types:

When the contact carrying current exceeds 10 A, the soldering connection at terminals is recommended.

For Cautions for Use, see Relay Technical Information

Looking for pricing, stock, or lifecycle information?

Click below to explore more details on WIN SOURCE:

-  [View JR1AF-TM-DC6V on WIN SOURCE](#)
-  [Panasonic Information](#)

Optimize Your Supply Chain with WIN SOURCE Solutions

-  Global Sourcing Solution
-  Obsolete Management
-  Cost Control Management
-  Shortage Management
-  Alternative Solution
-  Excess Inventory Management