



**THE DATASHEET OF  
J3011G21DNLT**



# PulseJack™ Surface Mount 1x1

## Description:

100 Base-TX (Fast Ethernet) surface mount RJ45 single port (1x1) Tab-UP/DOWN with or without LEDs Integrated Magnetics Connector, designed to support applications such as: Set Top Box and Network Interface Cars (NIC).



## Features and Benefits:

- ⊕ RoHS peak wave reflow temperature rating 245°C
- ⊕ JOC SMT product, reduced size and low cost alternative to JV series
- ⊕ Meets IEEE 802.3 specification
- ⊕ High performance for maximum EMI suppression
- ⊕ Minimum 1500Vrms isolation per IEEE 802.3 requirement

### Electrical Specifications @ 25°C - Operating Temperature 0°C to +70°C

RoHS Compliant Part No.	Turns Ratios		Tab Option Up/Down	LEDs <sup>1</sup> L/R	BST Circuit	EMI Finger	Insertion Loss (dB MAX)	Return Loss (dB MIN) 100Ω (±15Ω)				Crosstalk (dB MIN)			Common Mode Rejection (dB MIN)		Hipot (Vrms MIN) @ 60 Hz 1 MIN
	TX	RX						1-65 MHz	1-10 MHz	30 MHz	60-80 MHz	1-10 MHz	30-60 MHz	60-100 MHz	1-50 MHz	50-130 MHz	
JOC-0003NL	1CT:1	1CT:1	Down	No	No	No	-1.0	-18	-14	-10	-35	-35	-30	-20	-20	1500	
JOC-0004NL	1CT:1	1CT:1	Down	No	No	Yes	-1.0	-18	-14	-10	-35	-35	-30	-20	-20	1500	
JOC-0005NL	1CT:1	1CT:1	Down	No	Yes	No	-1.0	-18	-14	-10	-35	-35	-30	-20	-20	1500	
JOC-0006NL	1CT:1	1CT:1	Down	No	Yes	Yes	-1.0	-18	-14	-10	-35	-35	-30	-20	-20	1500	
JV006I2INL	1CT:1	1CT:1	Down	No	No	Yes	-1.0	-20	-16	-12	-40	-35	-30	-30	-20	1500	
JV011I2INL	1CT:1	1CT:1	Down	No	Yes	Yes	-1.0	-20	-16	-12	-40	-35	-30	-30	-20	1500	
JV026I2INL	1CTS:1	1CT:1	Down	No	Yes	Yes	-1.0	-20	-16	-12	-40	-35	-30	-30	-20	1500	
J3011G2IDNL	1CT:1	1CT:1	Up	G/Y	Yes	Yes	-1.0	-20	-16	-12	-40	-35	-30	-30	-20	1500	
J3026G01DNL	1CTS:1	1CT:1	Up	G/Y	Yes	No	-1.0	-20	-16	-12	-40	-35	-30	-30	-20	1500	
J3026G21DNL	1CTS:1	1CT:1	Up	G/Y	Yes	Yes	-1.0	-20	-16	-12	-40	-35	-30	-30	-20	1500	
JX30-0005NL <sup>3</sup>	1CT:1	1CT:1	Up	G/Y	Yes	Yes	-1.0	-20	-16	-12	-40	-35	-30	-30	-20	1500	

## Notes:

1. LEDs Left/Right: **G** = green; **Y** = yellow.
2. Add suffix "T" for Tape & Reel option (e.g. JOC-0004T).
3. Extended Temperature: -40° to 85° C

### RJ45 Durability Test Rating

Part Number	Mating Force (MAX)	Unmating Force (MAX)	Durability	Plug to Jack Retention (MIN)
JOC/JV/J3 Series	5 lbs./2.268 kgs.	5 lbs./2.268 kgs.	750 Insertions	20 lbs./9.072 kgs.

# PulseJack™

## Surface Mount 1x1

### RJ45 Material Specification

Part Number	Shield		Contact			Housing		MSL <sup>2</sup> Rating
	Material	Finish	Material	Plating Area <sup>3</sup>	Solder Area <sup>4</sup>	Material	Specification	
JOC/JV/J3 Series	Brass	20-40μ inches thick nickel over Brass	Phosphor Bronze	(X)μ inches gold over 30-80μ inches nickel	Tin matte finish	High Temp. Thermoplastic	UL 94 V-0	1

#### Notes:

1. Connector dimensions comply with FCC part 68 dimension requirements.
2. MSL = Moisture Sensitivity Level rating: 1-5 (highest rating = 1, lowest rating = 5)
3. (X) = 30 inches gold for JV and J30 platforms and 15 inches gold for JOC platform.
4. NL parts are tin matte finish over nickel.

### JOC Platform Schematics

#### JOC-0003NL/JOC-0004NL

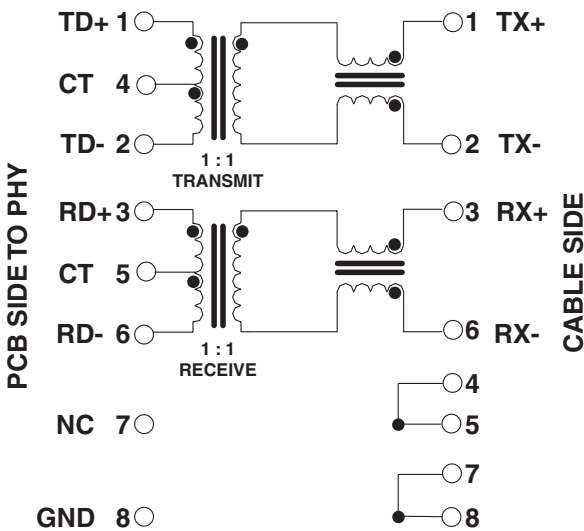

#### JOC-0005NL/JOC-0006NL

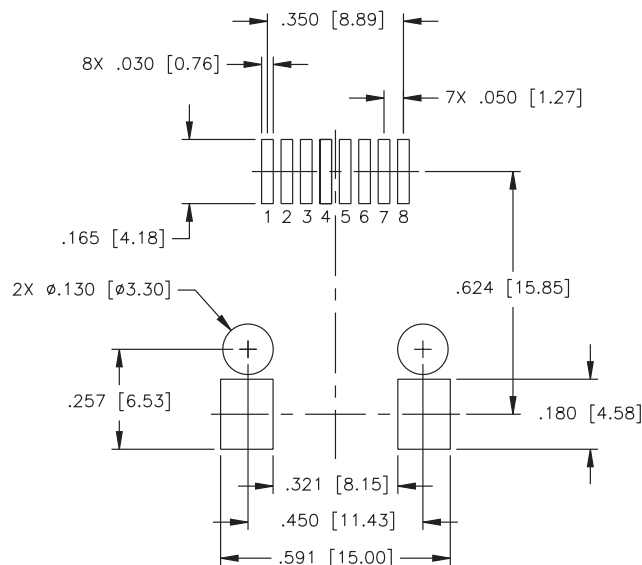
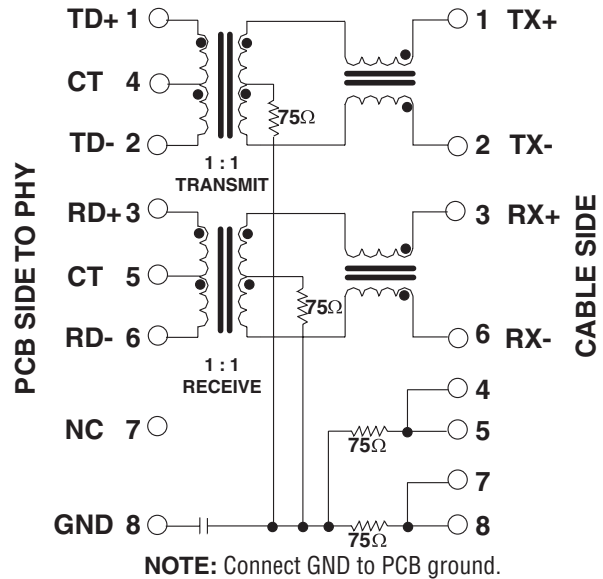

SUGGESTED FOOTPRINT (COMPONENT SIDE SHOWN)  
 DIMENSIONAL TOLERANCE: (UNLESS OTHERWISE SPECIFIED)  
 .XXX ±.003 [X.XX ±0.08]

# PulseJack™

## Surface Mount 1x1

### JV Platform Schematics

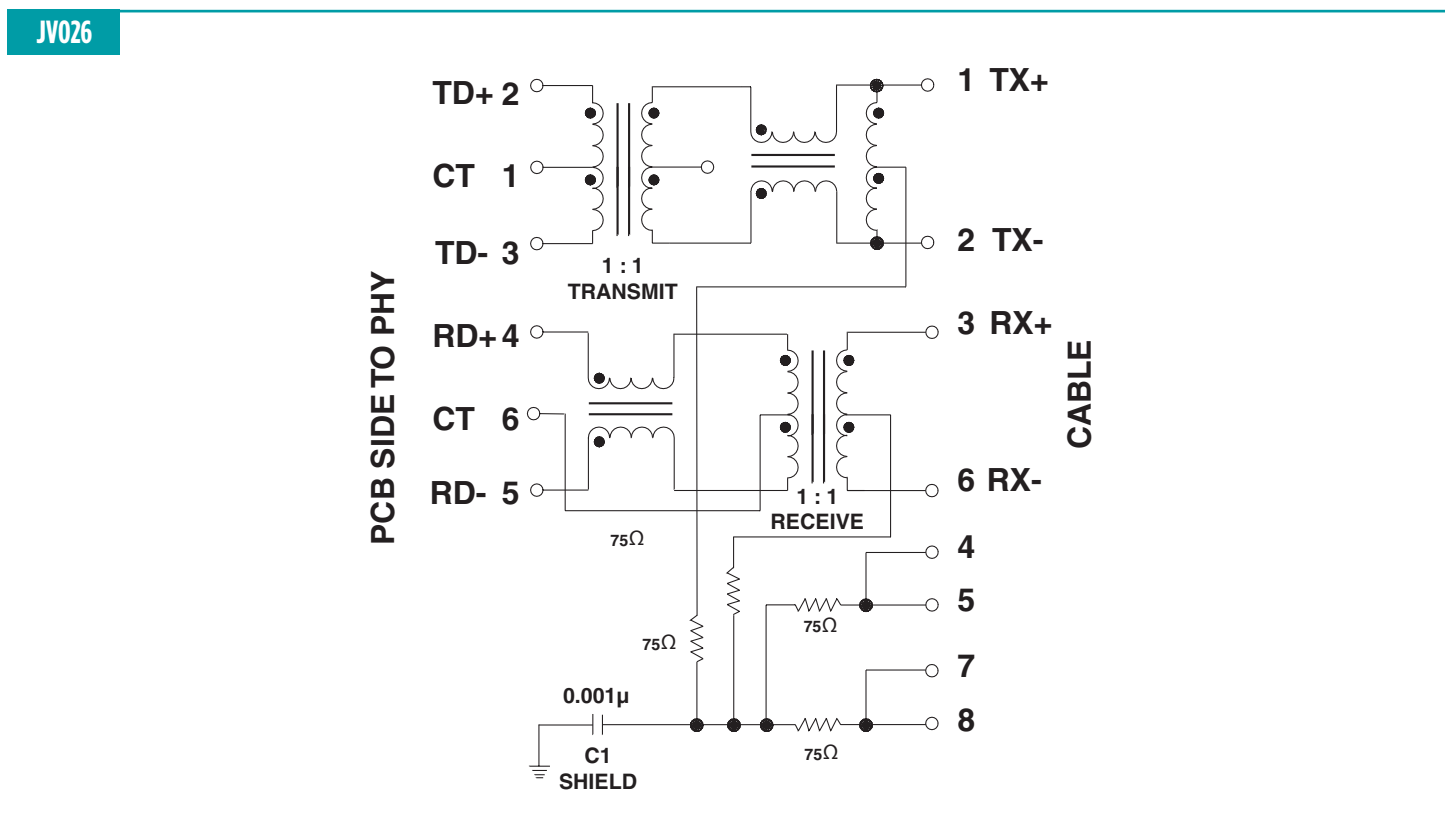
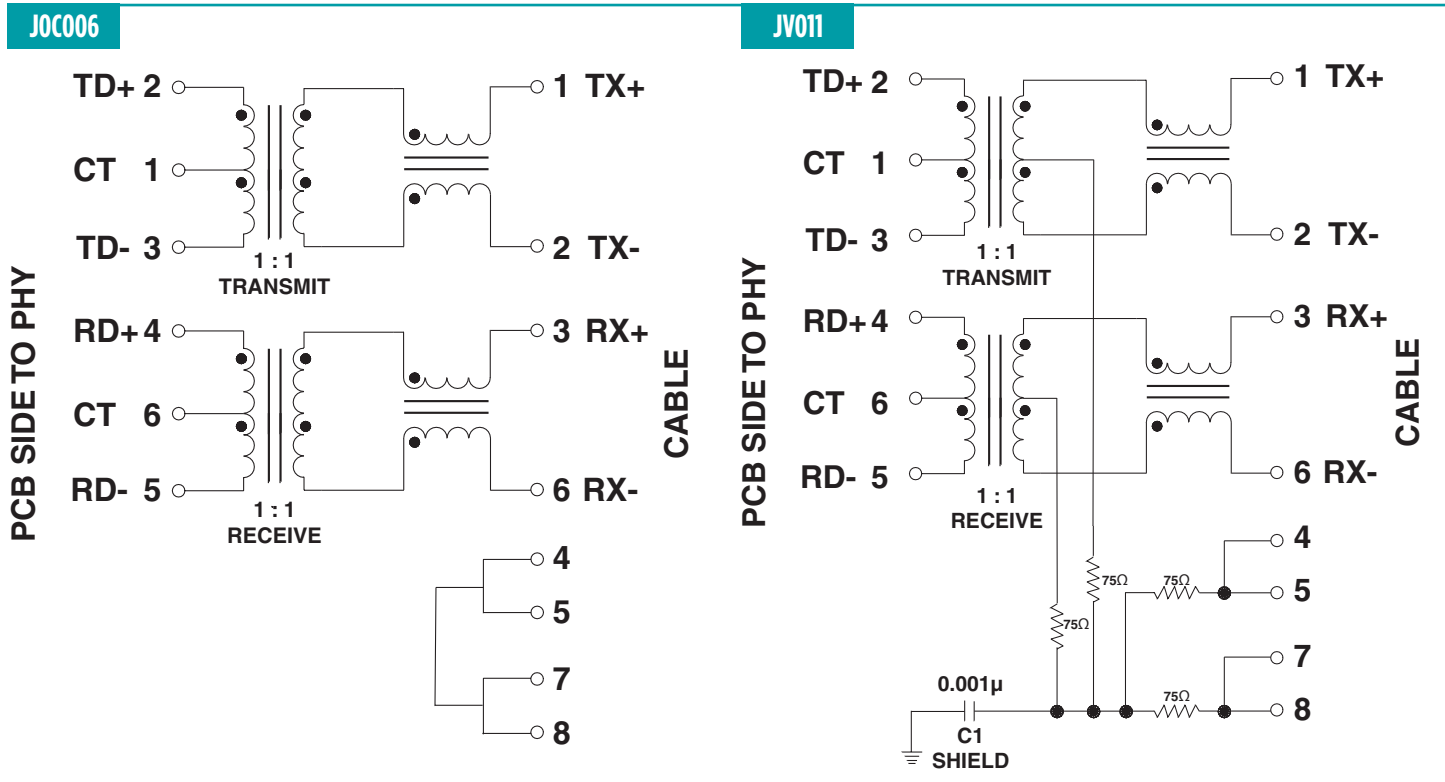

# PulseJack™ Surface Mount 1x1

## J3 Platform Schematics

J3011

J3026

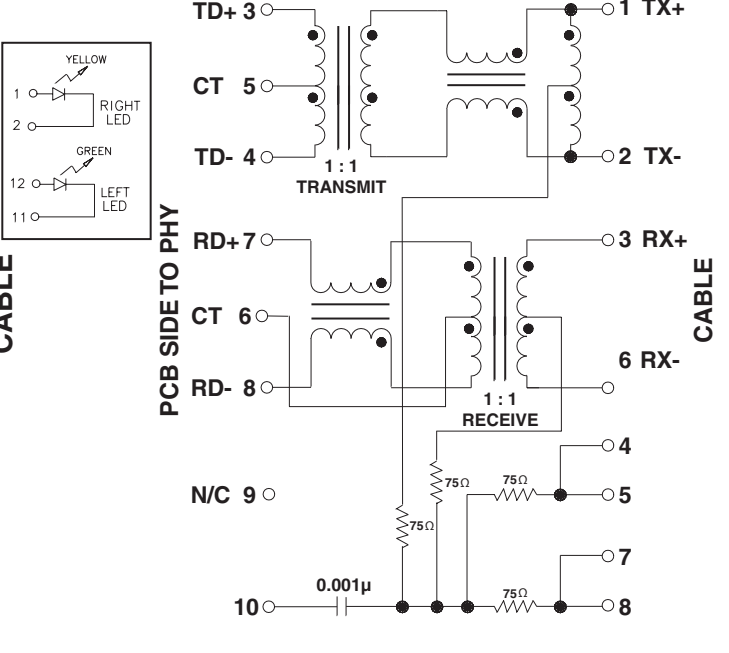
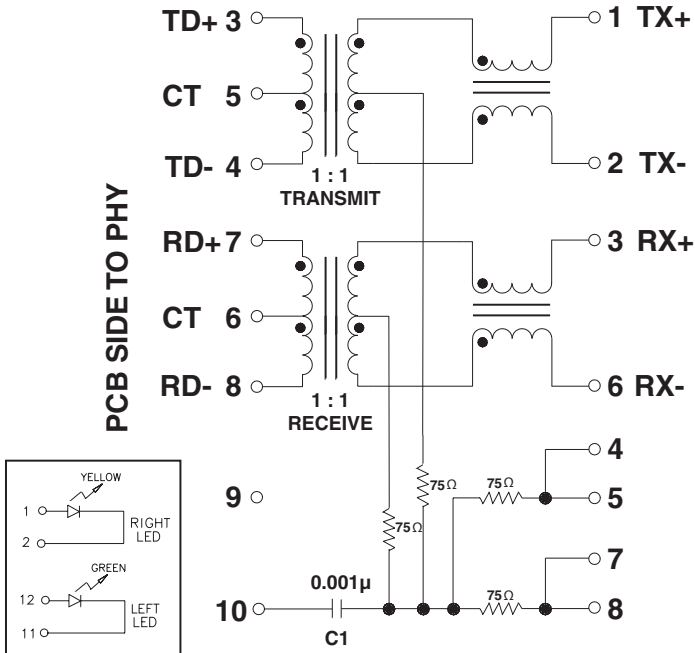

JX30-0005NL

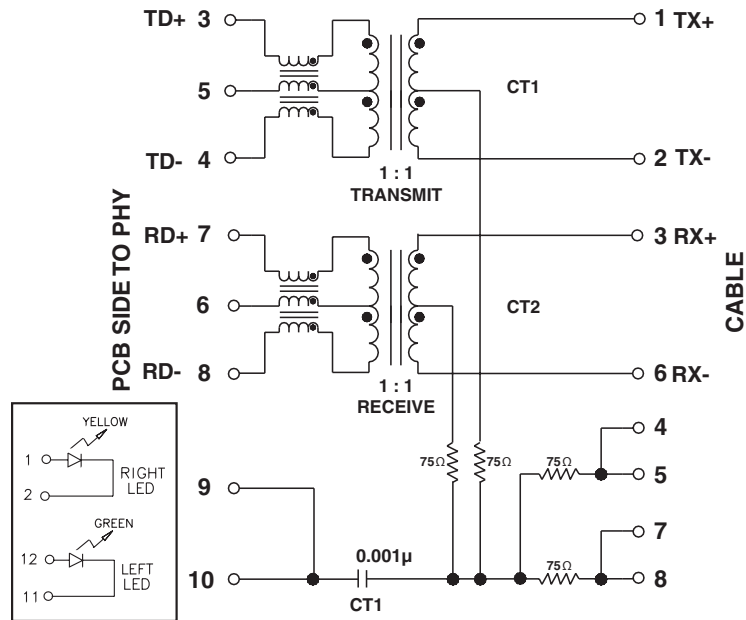

# PulseJack™ Surface Mount 1x1

## JOC Platform Mechanicals

JOC-0004NL/06NL

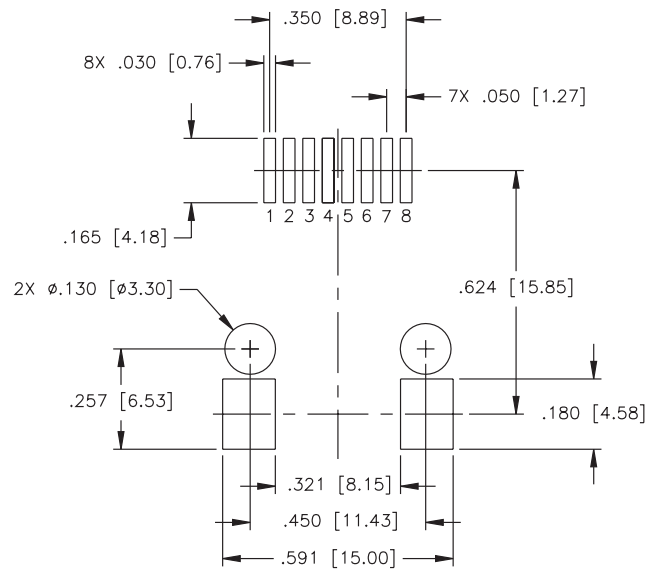
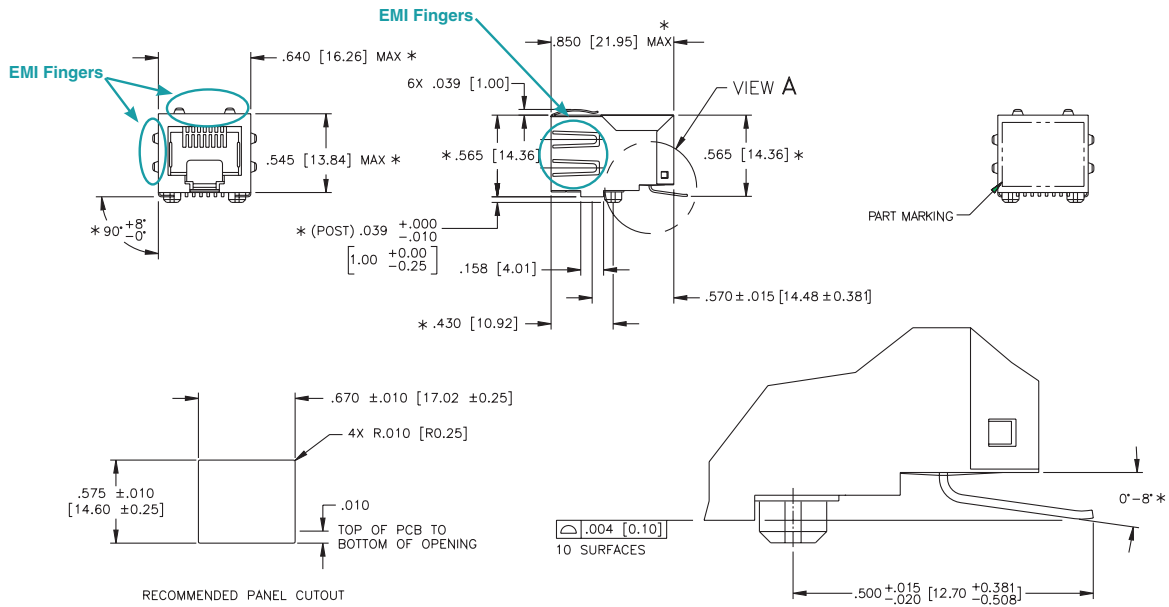

SUGGESTED FOOTPRINT (COMPONENT SIDE SHOWN)  
DIMENSIONAL TOLERANCE: (UNLESS OTHERWISE SPECIFIED)  
.XXX ±.003 [X.XX ±0.08]

# PulseJack™ Surface Mount 1x1

## JV Platform Mechanicals

JV Series

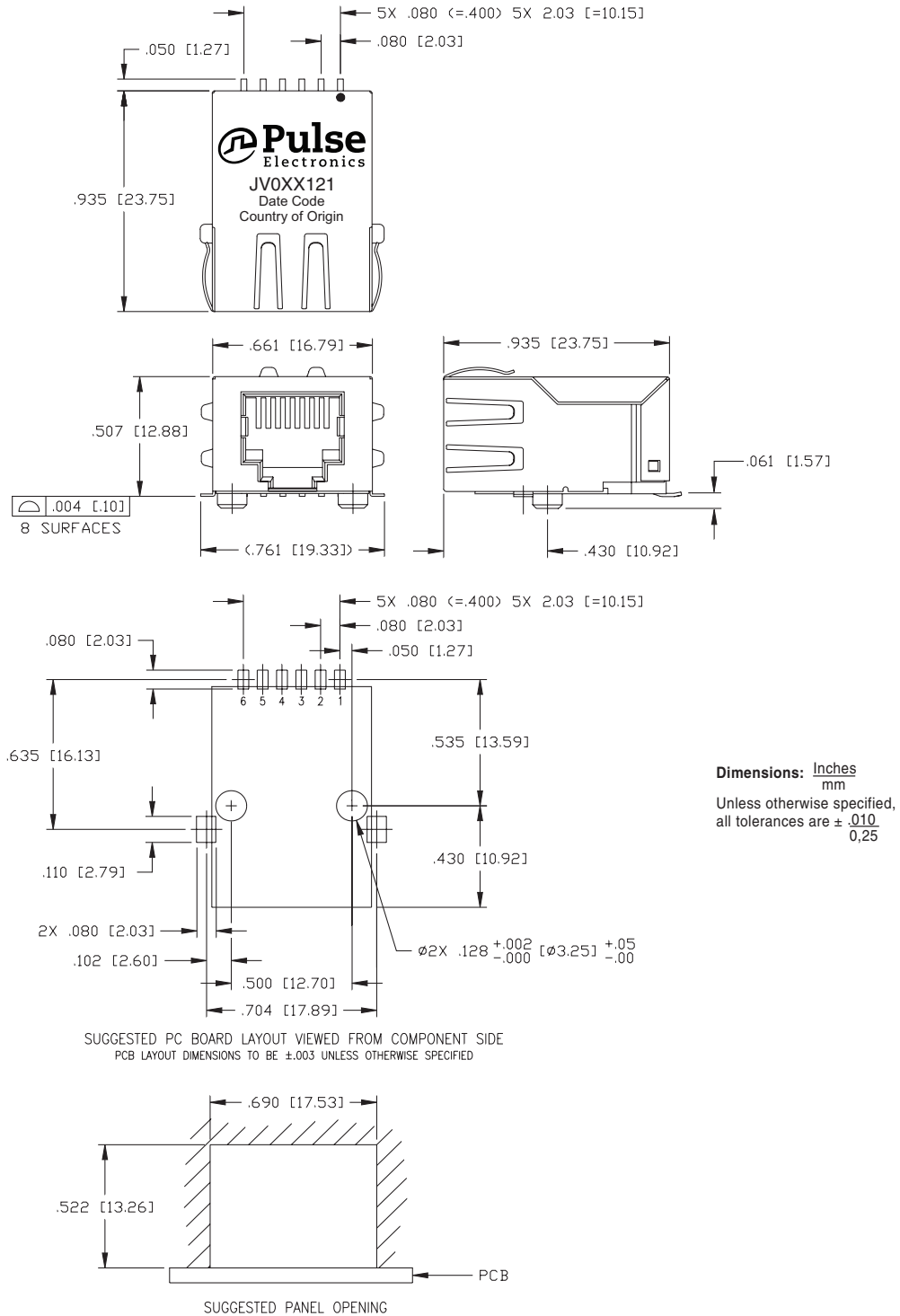

# PulseJack™ Surface Mount 1x1

## J3 Platform Mechanical

### J3 Series

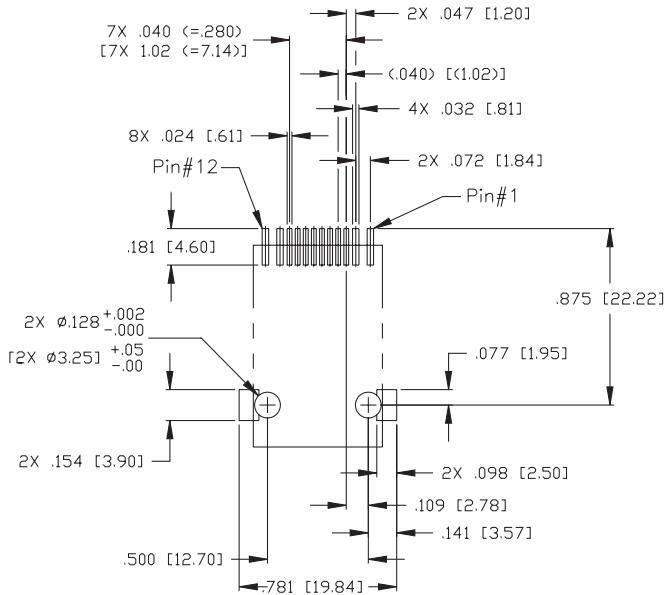
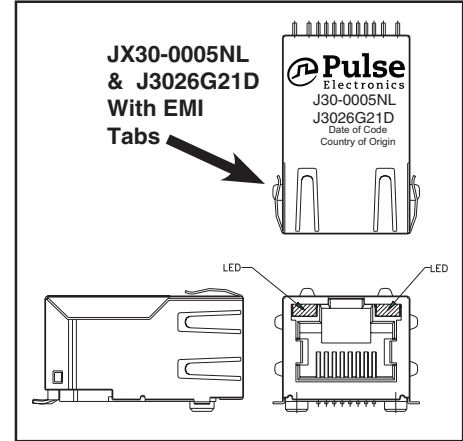
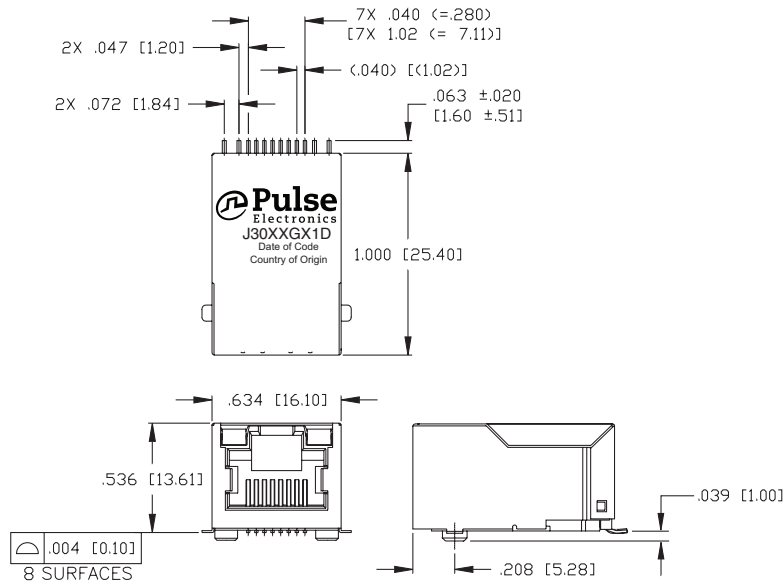

SUGGESTED PC BOARD LAYOUT VIEWED FROM COMPONENT SIDE  
 PCB LAYOUT DIMENSIONS TO BE  $\pm .003$  [ $\pm 0.08$ ] UNLESS OTHERWISE SPECIFIED

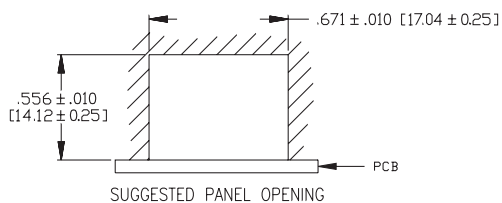

Dimensions:  $\frac{\text{Inches}}{\text{mm}}$   
 Unless otherwise specified,  
 all tolerances are  $\pm \frac{.010}{0,25}$

# PulseJack™

## Surface Mount 1x1

### JOC Application Note

This line of 10/100Base-TX SMT RJ45 1X1 Connector Magnetics Modules has been specifically designed for the implementation of a 10Base-T and 100Base-TX transmission over data-grade unshielded twisted pair cable (UTP-3, 5e and 6).

The connectors provide excellent EMI filtering and are suitable for adapter card and multiport applications. Pulse has worked closely with the leading IC manufacturers in providing these 10/100 solutions, thereby assuring compatibility with each transceiver.

The JOC series meets the stringent open circuit inductance requirements imposed by IEEE. When an 8mA DC current is applied across the transformer windings, the transformer will provide at least 350µH. The transformers

used in each module also provide 1500Vrms minimum isolation, wide bandwidth with minimal attenuation and fast rise times to minimize system level jitter.

The 1X1 SMT RJ45 connectors manufactured by Pulse are designed to meet all published specifications after exposure to surface mount soldering temperatures. The SMT are robust enough to withstand convection and infrared reflow solder temperatures. Additionally, compliant leads provide excellent solder-joint reliability with a coplanarity of 0.10 (0.004”).

**Note:** Modules are packaged in trays, unless Tape & Reel is specified (ex: JOC-0003NL for Trays and JOC-0003NLT for Tape & Reel).

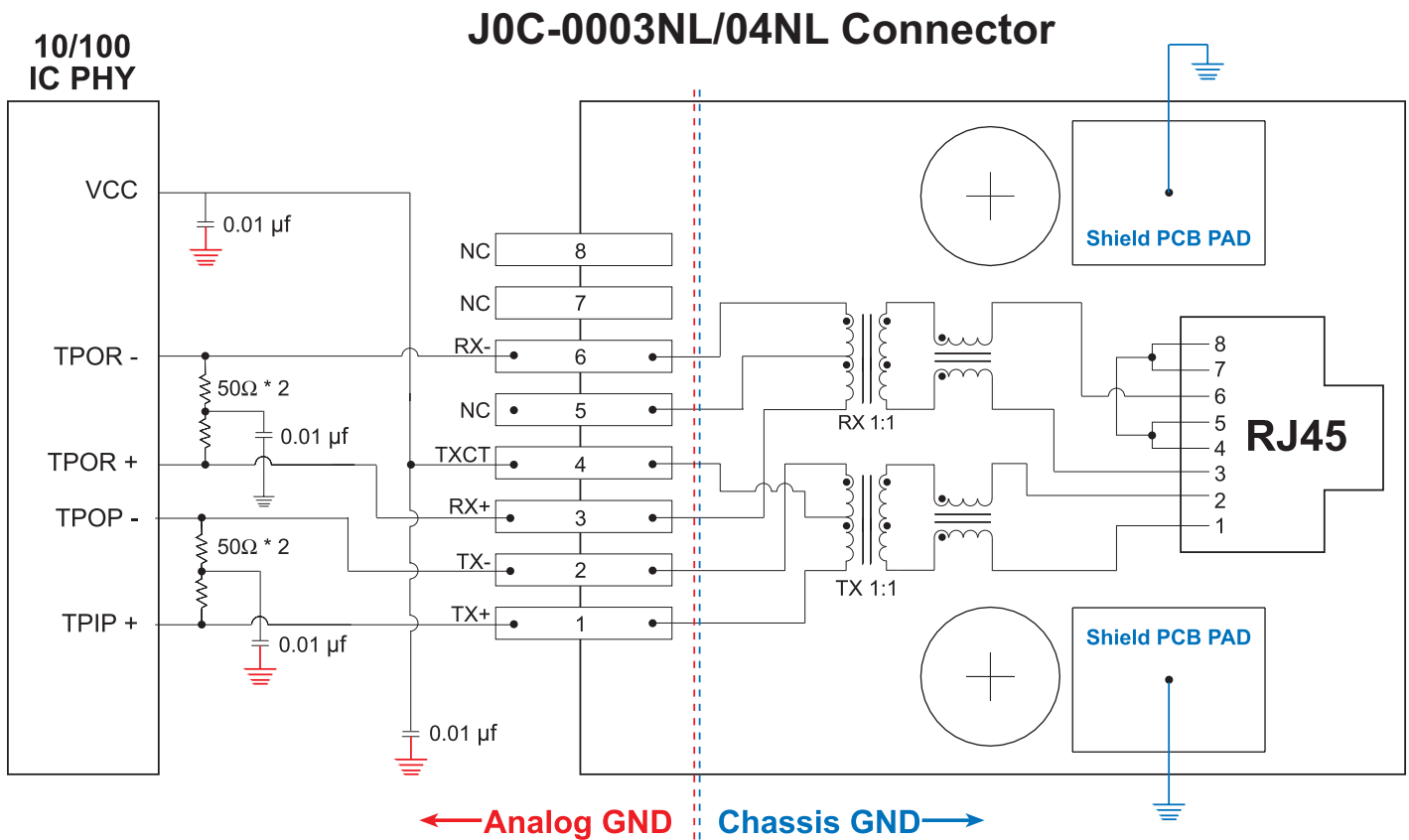

NOTE: Connector design not to scale

### PCB Layout Recommendations:

1. For maximum EMI suppression (electromagnetic interference) place the decoupling capacitors adjacent to VCC and 50Ω connections.
2. Connections to ground should be as short as possible.
3. Connections between the 10/100 IC and the SMT connector should be direct (ideally no change in direction) and of minimum length.

# PulseJack™

## Surface Mount 1x1

### JV Application Note

This line of 10/100Base-TX SMT RJ45 1X1 Connector Magnetics Modules has been specifically designed for the implementation of a 10Base-T and 100Base-TX transmission over data-grade unshielded twisted pair cable (UTP-3, 5e and 6).

The connectors provide excellent EMI filtering and are suitable for adapter card and multiport applications. Pulse has worked closely with the leading IC manufacturers in providing these 10/100 solutions, thereby assuring compatibility with each transceiver.

The JCO series meets the stringent open circuit inductance requirements imposed by IEEE. When an 8mA DC current is applied across the transformer windings, the transformer will provide at least 350µH. The transformers used in each module also provide 1500Vrms minimum

isolation, wide bandwidth with minimal attenuation and fast rise times to minimize system level jitter.

The 1X1 SMT RJ45 connectors manufactured by Pulse are designed to meet all published specifications after exposure to surface mount soldering temperatures. The SMT are robust enough to withstand convection and infrared reflow solder temperatures. Additionally, compliant leads provide excellent solder-joint reliability with a coplanarity of 0.10 (0.004”).

**Note:** Modules are packaged in trays, unless Tape & Reel is specified. Please add the suffix “T” for Tape & Reel orders (ex: JVO006I21T). Add the suffix “NL” for RoHS compliant parts (ex: JVO06I21NL for Trays and JVO06I21NLT for Tape & Reel).

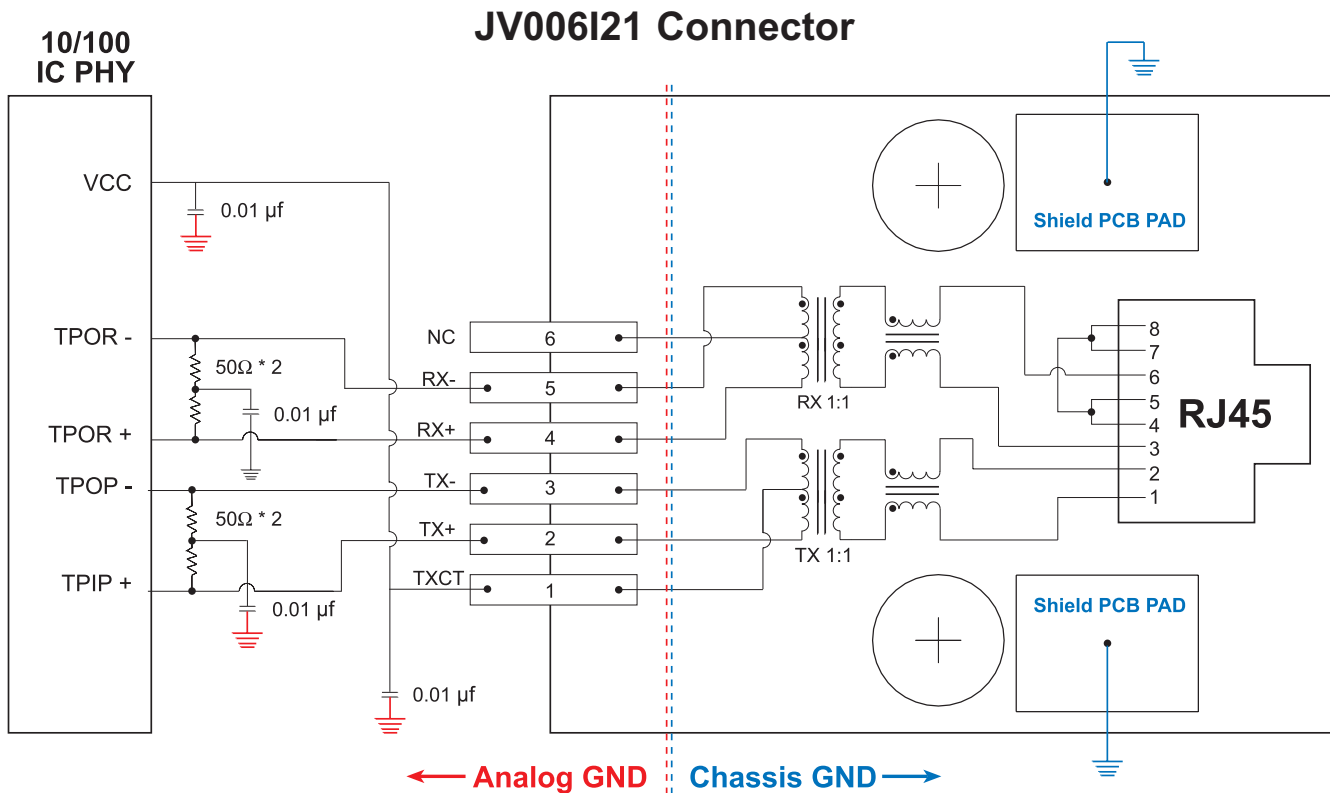

### PCB Layout Recommendations:

1. For maximum EMI suppression (electromagnetic interference) place the decoupling capacitors adjacent to VCC and 50Ω connections.
2. Connections to ground should be as short as possible.
3. Connections between the 10/100 IC and the SMT connector should be direct (ideally no change in direction) and of minimum length.

# PulseJack™ Surface Mount 1x1

## JOC Packaging Specifications

JOC Series

Weight.....7.07 grams  
Tape & Reel..... 90/reel  
Tray ..... 80/tray  
Tape ..... 44x32mm  
Tube ..... 25/tube

### Tape and Reel Specification

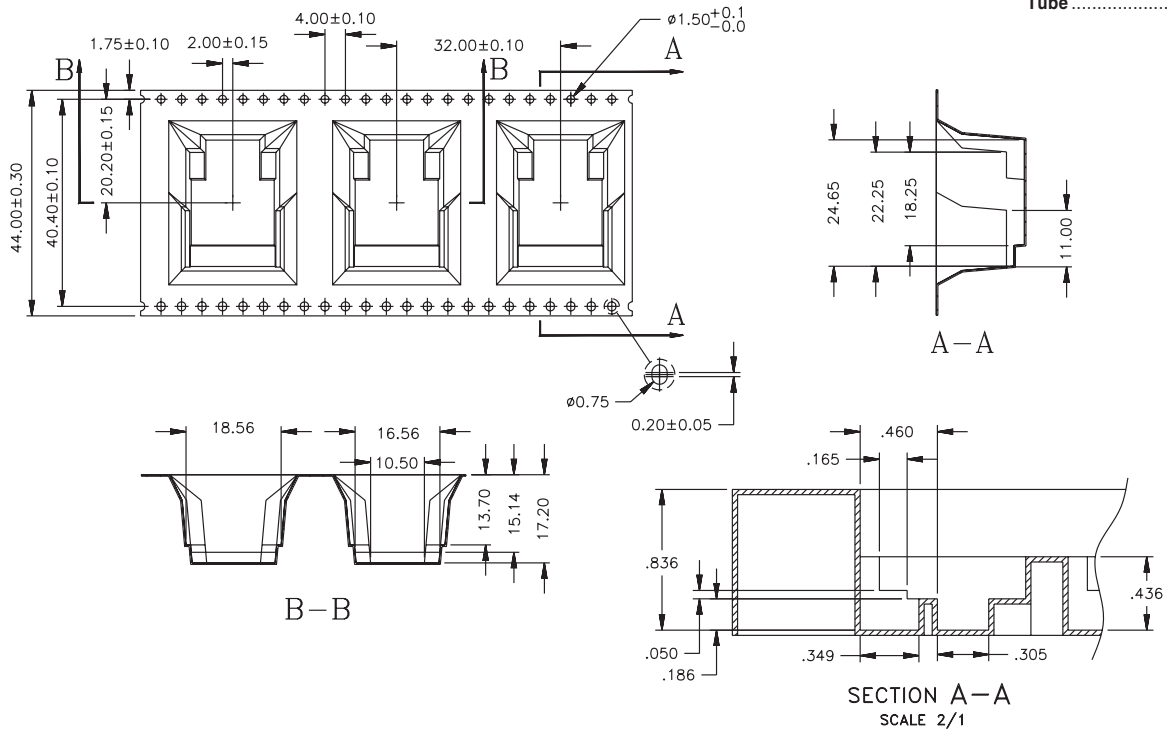

### Tray Specification

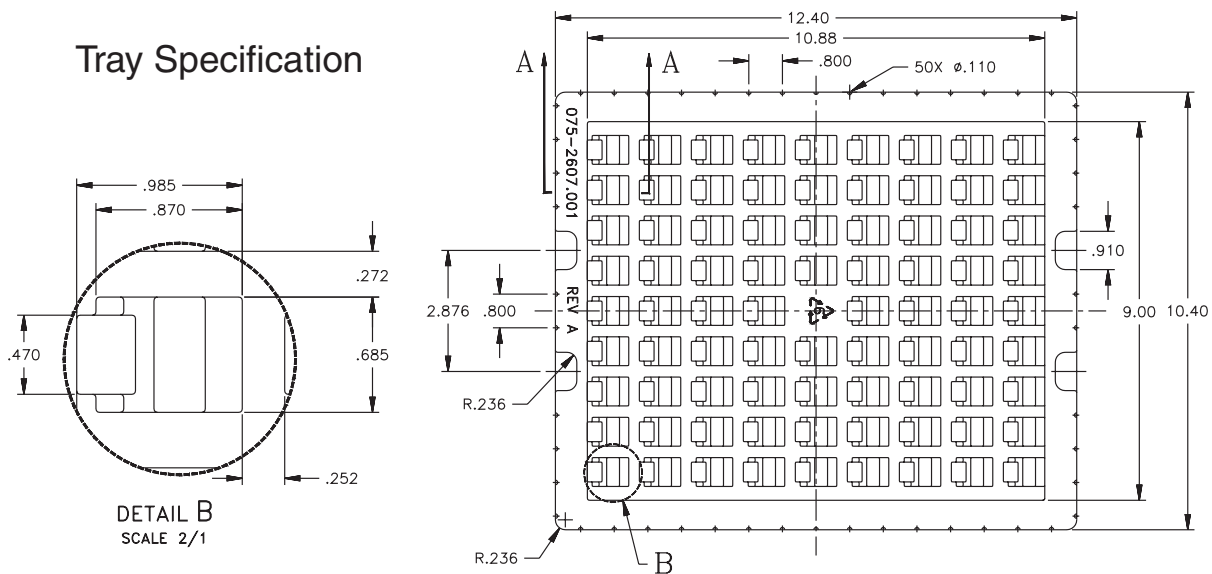

# PulseJack™ Surface Mount 1x1

## JV Packaging Specifications

JV Series

Weight .....6.6 grams  
Tape & Reel ..... 150/reel  
Tray ..... 45/tray  
Tape ..... 44x32mm

### Tape and Reel Specification

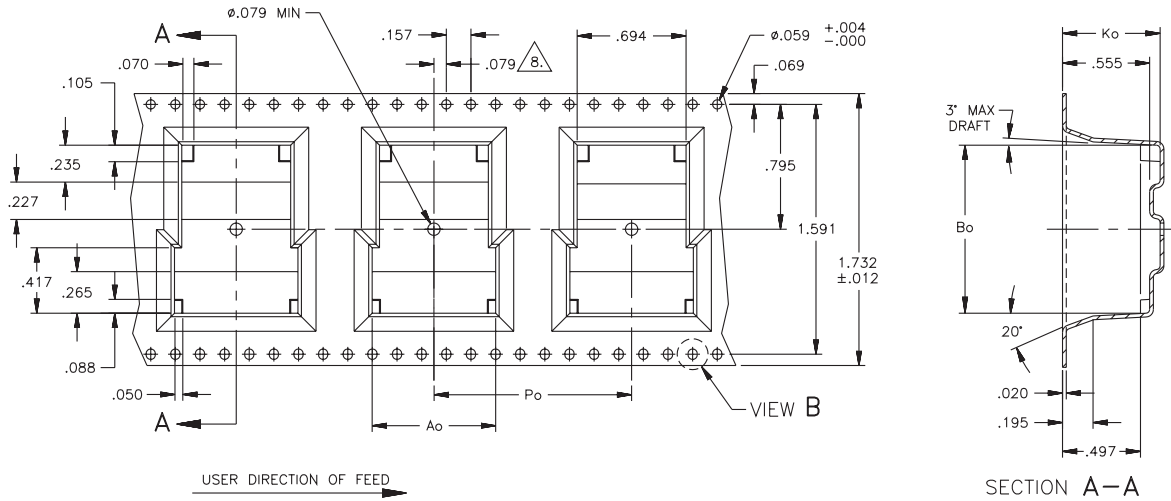

DIM CHART	
Ao	.787
Bo	1.050
Ko	.618
Po	1.260

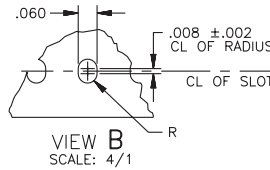

### Tray Specification

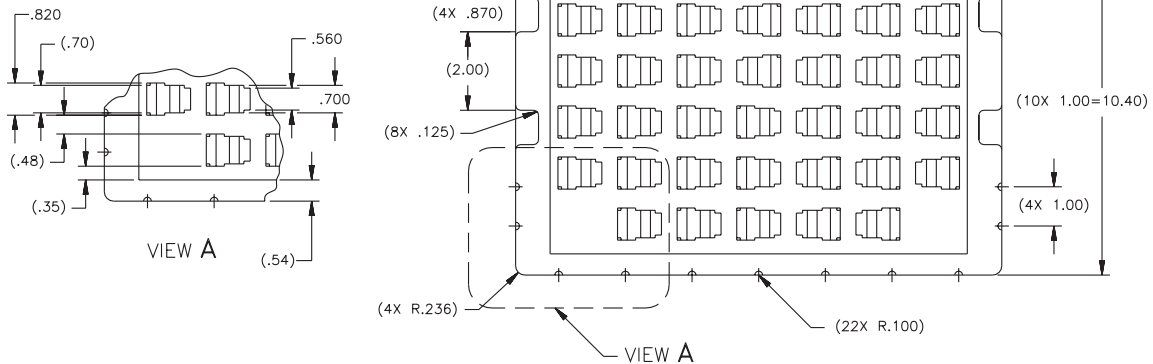

# PulseJack™ Surface Mount 1x1

## J3 Packaging Specifications

J3 Series

### Tape and Reel Specification

Weight.....8.1 grams  
Tape & Reel.....75/reel  
Tray .....45/tray  
Tape .....56x32mm

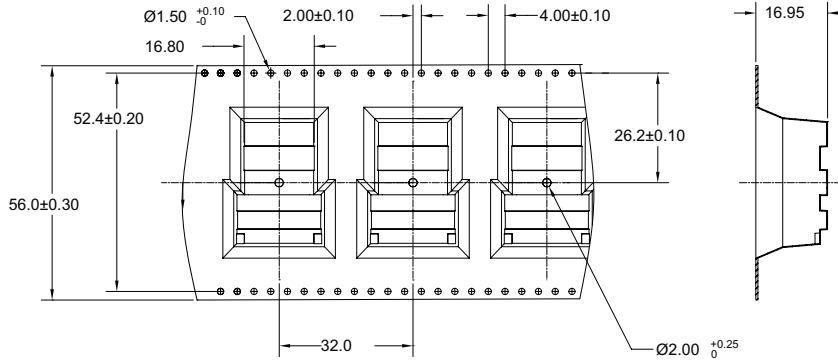

### Tray Specification

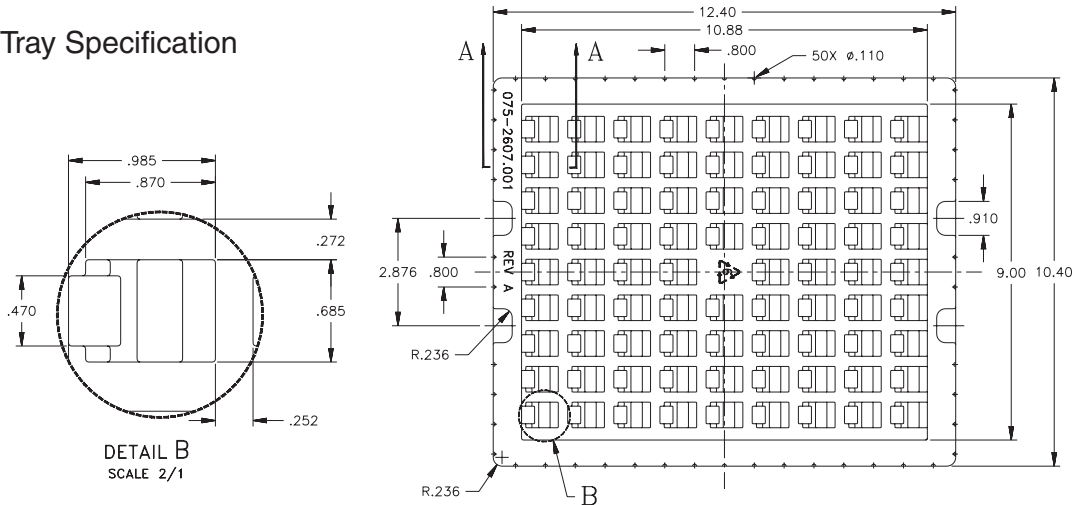

### For More Information:

Americas - [prodinfo@networkamericas@pulseelectronics.com](mailto:prodinfo@networkamericas@pulseelectronics.com) | Europe - [comms@pulseelectronics.com](mailto:comms@pulseelectronics.com) | Asia - [prodinfo@networkapac@pulseelectronics.com](mailto:prodinfo@networkapac@pulseelectronics.com)

Performance warranty of products offered on this data sheet is limited to the parameters specified. Data is subject to change without notice. Other brand and product names mentioned herein may be trademarks or registered trademarks of their respective owners. © Copyright, 2019. Pulse Electronics, Inc. All rights reserved.

## Looking for pricing, stock, or lifecycle information?

Click below to explore more details on WIN SOURCE:

 [View J3011G21DNLT on WIN SOURCE](#)

 [Pulse Information](#)

## Optimize Your Supply Chain with WIN SOURCE Solutions

-  Global Sourcing Solution
-  Obsolete Management
-  Cost Control Management
-  Shortage Management
-  Alternative Solution
-  Excess Inventory Management