



**THE DATASHEET OF  
J1012F21KNL**







# PulseJack™ 1x1 Tab-UP RJ45

## Description:

100 Base-TX (Fast Ethernet) RJ45 1x1 Tab-UP with LEDs 8-pin (J1 series) and 6-pin (JP series) integrated magnetics connector, designed to support applications, such as ADSL modems, LAN-on-Motherboard, and Hub and Switches.



## Features and Benefits:

-  RoHS peak wave solder temperature rating 260°C Suitable for CAT 5 & 6 UTP cable or better
-  Meets IEEE 802.3 specification
-  350µH minimum OCL with 8mA bias current
-  High performance for maximum EMI suppression

Electrical Specifications @ 25°C - Operating Temperature 0°C to +70°C

RoHS Compliant Part Number (Number of Ports)	Turns Ratios		EMI Fingers	LEDs L/R	Insertion Loss (dB TYP)	Return Loss (dB TYP) 100Ω (±15Ω)					Crosstalk (dB TYP)			Common Mode Rejection (dB TYP)		Hipot (Vrms) @60Hz 1 MIN
	TX	RX				1-65 MHz	1-10 MHz	10-30 MHz	30-60 MHz	60-80 MHz	1-30 MHz	30-60 MHz	60-100 MHz	1-50 MHz	50-150 MHz	
J1006F01PNL	1CT:1	1CT:1	No	G/Y	-1.0	-20	-16	-12	-10	-40	-35	-30	-30	-20	1500	
J1006F21NL	1CT:1	1CT:1	YES	NONE	-1.0	-20	-16	-12	-10	-40	-35	-30	-30	-20	1500	
J1011F01PNL	1CT:1	1CT:1	No	G/Y	-1.0	-20	-16	-12	-10	-40	-35	-30	-30	-20	1500	
J1011F21PNL	1CT:1	1CT:1	YES	G/Y	-1.0	-20	-16	-12	-10	-40	-35	-30	-30	-20	1500	
J1012F01CNL	1CT:1	1CT:1	No	Y/G	-1.0	-20	-16	-12	-10	-40	-35	-30	-30	-20	1500	
J1012F21CNL	1CT:1	1CT:1	YES	Y/G	-1.0	-20	-16	-12	-10	-40	-35	-30	-30	-20	1500	
J1012F21KNL	1CT:1	1CT:1	YES	G/G	-1.0	-20	-16	-12	-10	-40	-35	-30	-30	-20	1500	
J1012F21RNL	1CT:1	1CT:1	YES	RG/R Y	-1.0	-20	-16	-12	-10	-40	-35	-30	-30	-20	1500	
J1026F01NL	1CT:1	1CT:1	No	NONE	-1.0	-20	-16	-12	-10	-40	-35	-30	-30	-20	1500	
J1026F01PNL	1CT:1	1CT:1	No	G/Y	-1.0	-20	-16	-12	-10	-40	-35	-30	-30	-20	1500	
J1026F21CNL	1CT:1	1CT:1	YES	Y/G	-1.0	-20	-16	-12	-10	-40	-35	-30	-30	-20	1500	
JP006821UNL	1CT:1	1CT:1	YES	G_0/Y	-1.0	-20	-16	-12	-10	-40	-35	-30	-30	-20	1500	
JP011821UNL	1CT:1	1CT:1	YES	G_0/Y	-1.0	-20	-16	-12	-10	-40	-35	-30	-30	-20	1500	
JP026821UNL	1CT:1	1CT:1	YES	G_0/Y	-1.0	-20	-16	-12	-10	-40	-35	-30	-30	-20	1500	

## Notes:

- LEDs Left/Right: G = green, Y = yellow, G\_0 = green/orange bi-color LED, R = LEDs with resistors.

# PulseJack™

## 1x1 Tab-UP RJ45

### RJ45 Durability Test Rating

Part Number	Mating Force (MAX)	Unmating Force (MAX)	Durability	Plug to Jack Retention (MIN)
JP/J1 Series	5 lbs./2.268 kgs.	5 lbs./2.268 kgs.	750 Insertions	20 lbs./9.072 kgs.

### RJ45 Material Specification

Part Number	Shield		Contact			Housing		MSL <sup>2</sup> Rating
	Material	Finish	Material	Plating Area	Solder Area	Material	Specification	
JP/J1 Series	Brass	10-20μ inches thick nickel over 10-20μ inches Brass	Phosphor Bronze	Nickel underplating and selective gold plating 15μ inches	Tin matte finish	Thermoplastic	UL 94 V-0	1

#### Notes:

1. Connector dimensions comply with FCC dimension requirements. 2. MSL = Moisture Sensitivity Level rating from 1 to 5 (highest rating = 1, lowest rating = 5)

### J1 Series Mechanicals

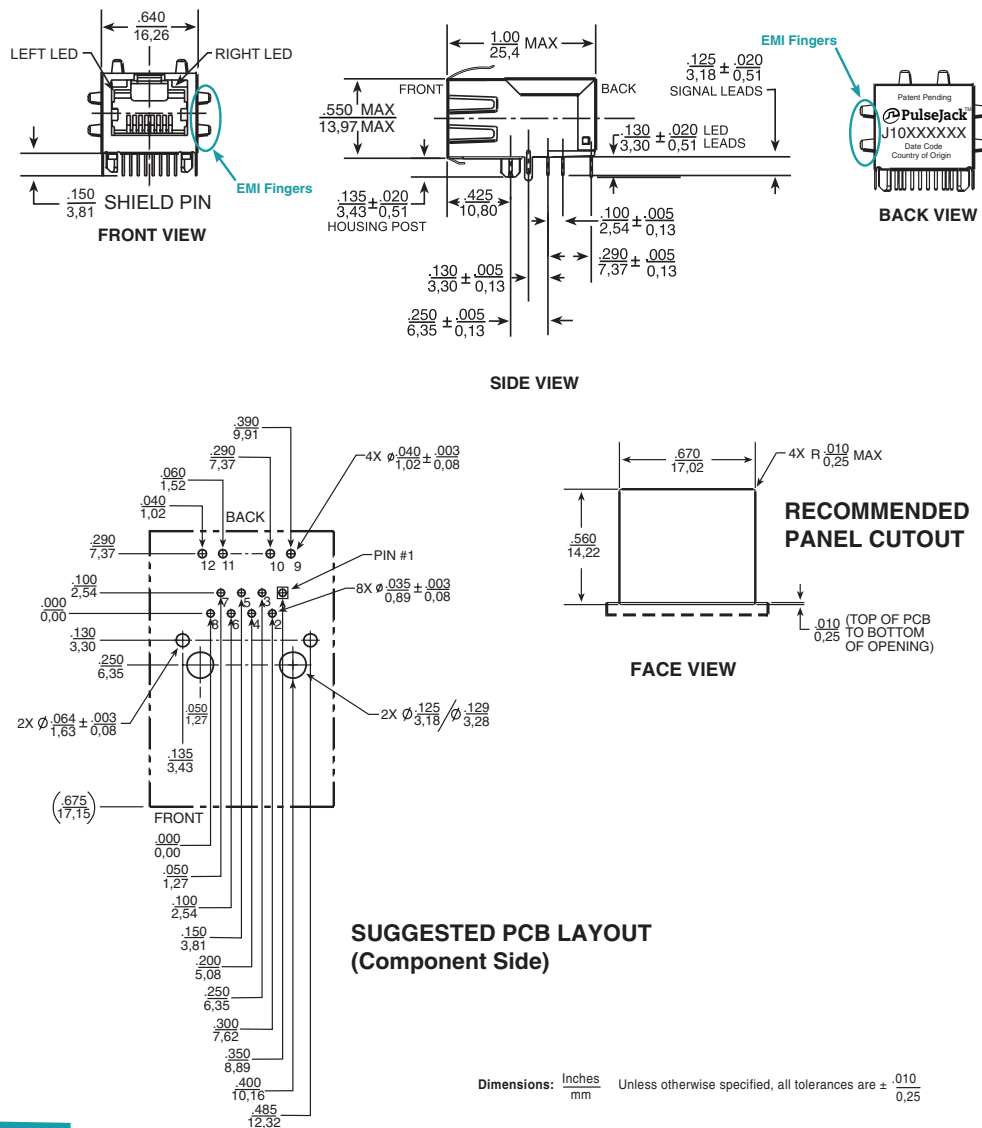

Dimensions:  $\frac{\text{Inches}}{\text{mm}}$  Unless otherwise specified, all tolerances are  $\pm \frac{.010}{0.25}$

# PulseJack™

## 1x1 Tab-UP RJ45

### J1 Series Electrical Schematics

J1006

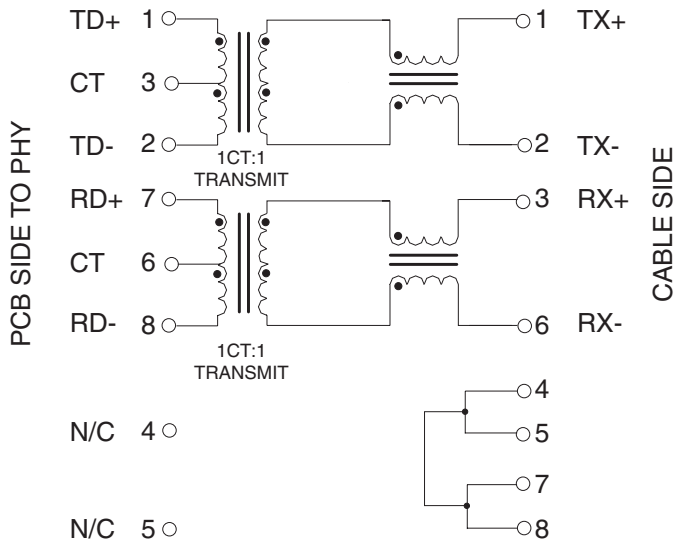

Note: Connect CHS GND to PCB ground.

J1011

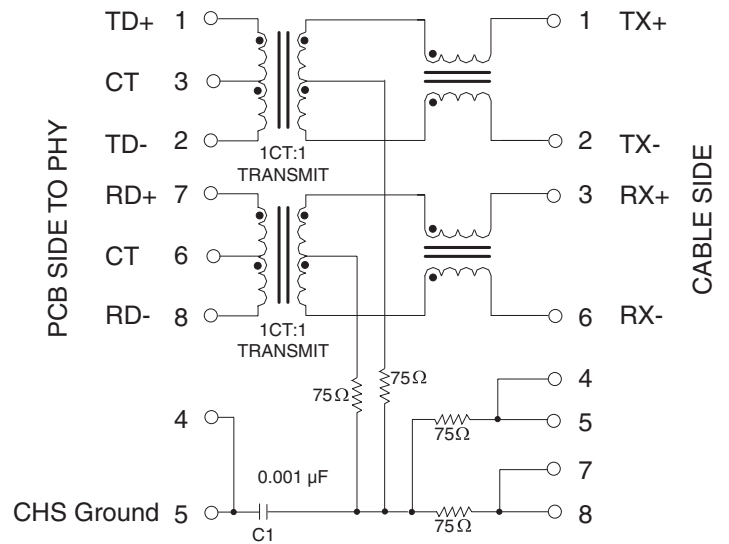

Note: Connect CHS GND to PCB ground.

J1012

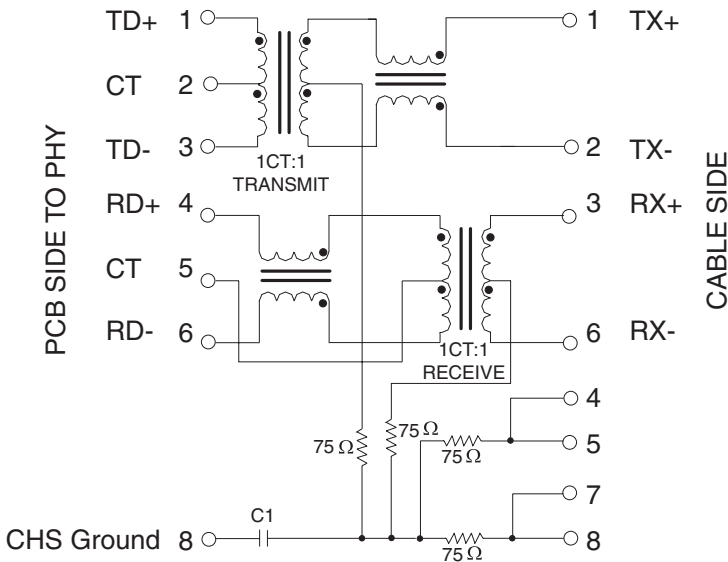

Note: Connect CHS GND to PCB ground.

J1026

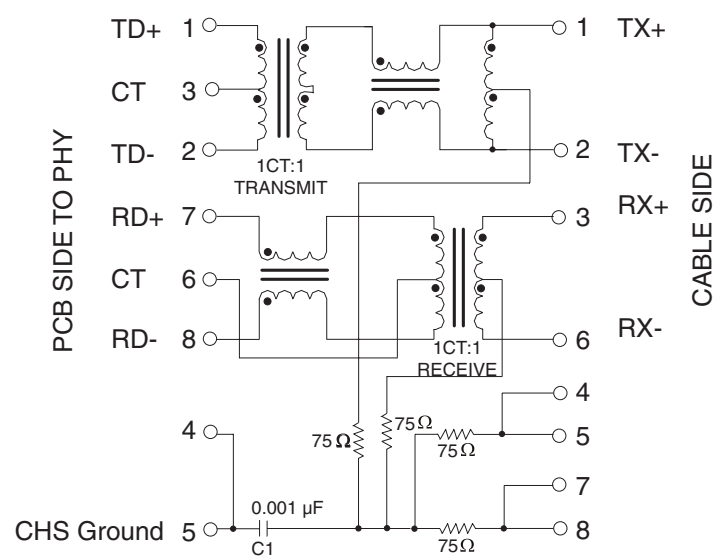

Note: Connect CHS GND to PCB ground.

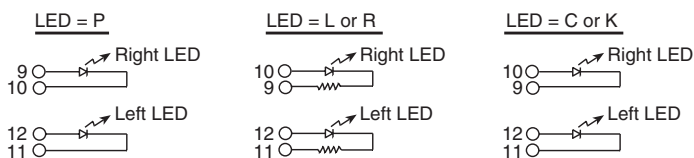

Standard LED	Wavelength	Forward* V(MAX)	(TYP)
Yellow	585 nm	2.5 V	2.1 V
Green	565 nm	2.5 V	2.2 V

\* With a forward current of 20 mA

# PulseJack™ 1x1 Tab-UP RJ45

## JP Series Mechanicals

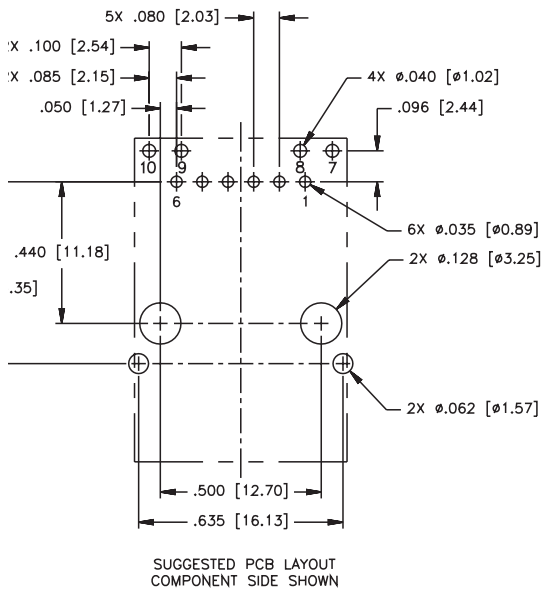
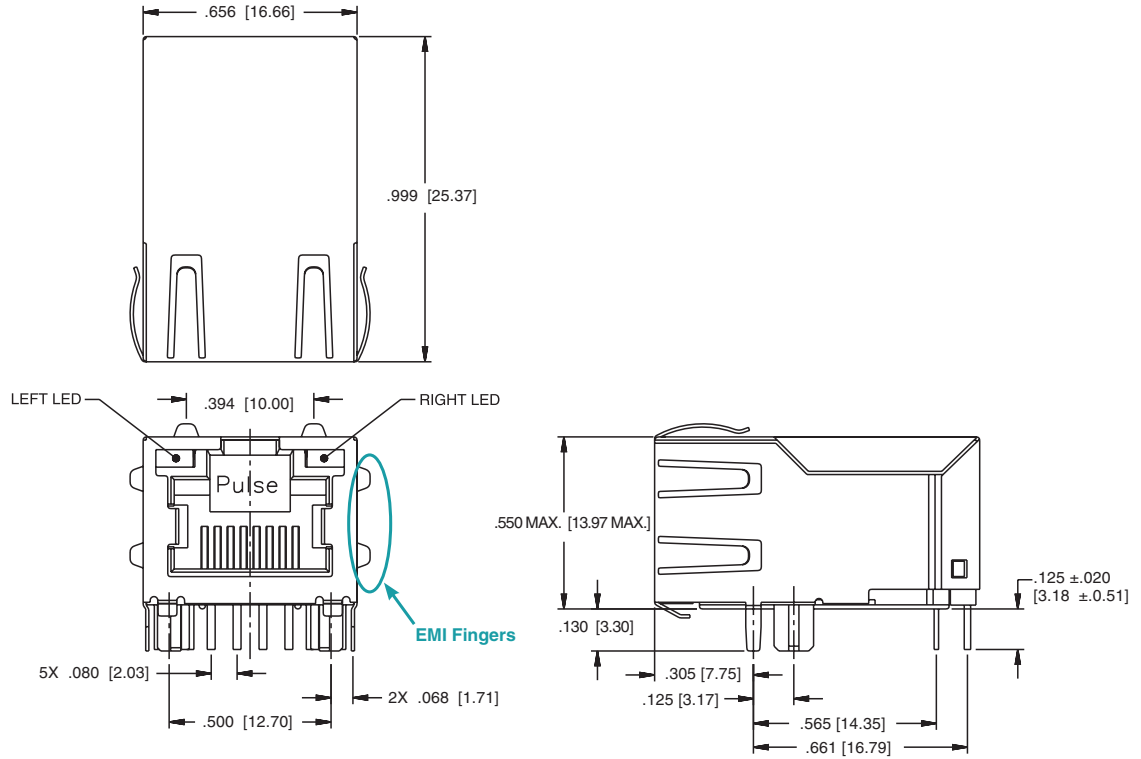

Dimensions:  $\frac{\text{Inches}}{\text{mm}}$  Unless otherwise specified, all tolerances are  $\pm \frac{.010}{0,25}$

# PulseJack™

## 1x1 Tab-UP RJ45

### JP Series Electrical Schematics

#### JP006

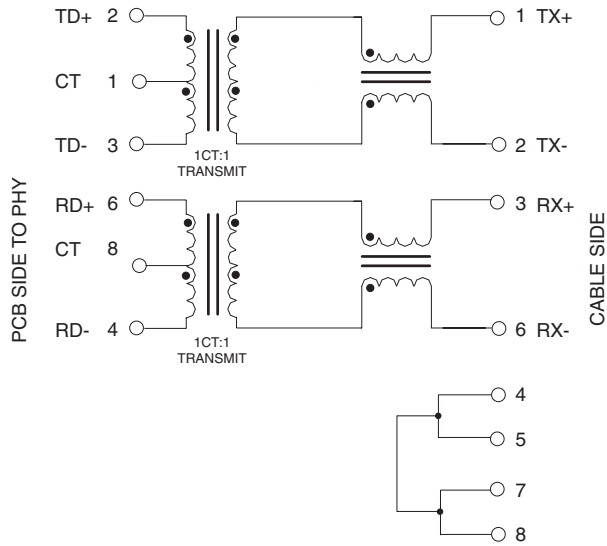

Note: Connect CHS GND to PCB ground.

#### JP011

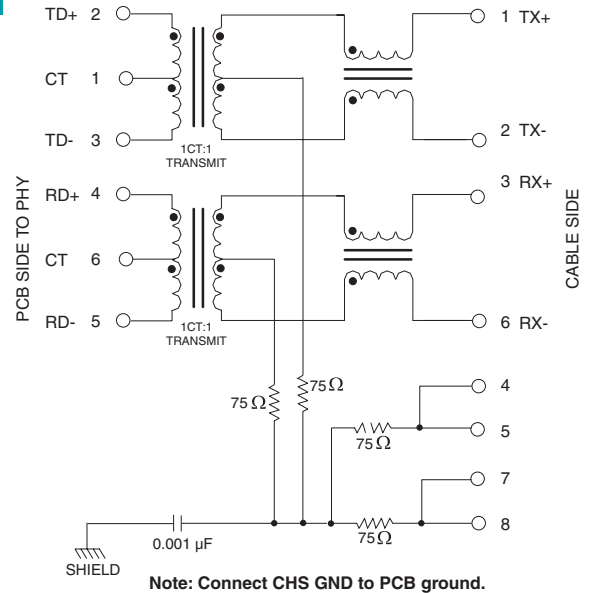

Note: Connect CHS GND to PCB ground.

#### JP026

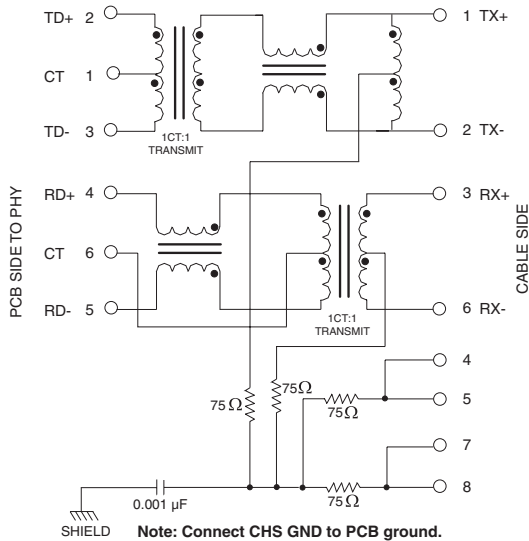

Note: Connect CHS GND to PCB ground.

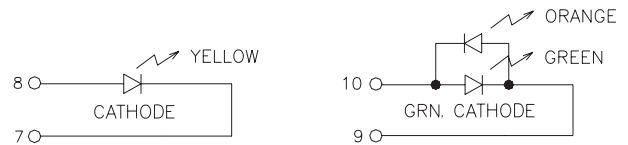

Standard LED	Wavelength	Forward* V (MAX)	(TYP)
Yellow	585 nm	2.5 V	2.1 - 2.2 V
Green	565 nm	2.5 V	2.1 - 2.2 V
Orange	610 nm	2.5 V	2.1 - 2.2 V

\* With a forward current of 20 mA

### For More Information:

Americas - [prodinfonetworkamericas@pulseelectronics.com](mailto:prodinfonetworkamericas@pulseelectronics.com) | Europe - [comms-Apps-Europe@pulseelectronics.com](mailto:comms-Apps-Europe@pulseelectronics.com) | Asia - [prodinfonetworkapac@pulseelectronics.com](mailto:prodinfonetworkapac@pulseelectronics.com)

Performance warranty of products offered on this data sheet is limited to the parameters specified. Data is subject to change without notice. Other brand and product names mentioned herein may be trademarks or registered trademarks of their respective owners. © Copyright, 2019, Pulse Electronics, Inc. All rights reserved.

## Looking for pricing, stock, or lifecycle information?

Click below to explore more details on WIN SOURCE:

 [View J1012F21KNL on WIN SOURCE](#)

 [Pulse Information](#)

## Optimize Your Supply Chain with WIN SOURCE Solutions

-  Global Sourcing Solution
-  Obsolete Management
-  Cost Control Management
-  Shortage Management
-  Alternative Solution
-  Excess Inventory Management