



**THE DATASHEET OF  
ISPPAC-POWR1220AT8-01TN100I**



### Features

- Monitor, Control, and Margin Multiple Power Supplies**
  - Simultaneously monitors up to 12 power supplies
  - Provides up to 20 output control signals
  - Provides up to eight analog outputs for margining/trimming power supply voltages
  - Programmable digital and analog circuitry
- Power Supply Margin and Trim Functions**
  - Trim and margin up to eight power supplies
  - Dynamic voltage control through I<sup>2</sup>C
  - Four hardware selectable voltage profiles
  - Independent Digital Closed-Loop Trim function for each output
- Embedded PLD for Sequence Control**
  - 48-macrocell CPLD implements both state machines and combinatorial logic functions
- Embedded Programmable Timers**
  - Four independent timers
  - 32µs to 2 second intervals for timing sequences
- Analog Input Monitoring**
  - 12 independent analog monitor inputs
  - Differential inputs for remote ground sense
  - Two programmable threshold comparators per analog input
  - Hardware window comparison
  - 10-bit ADC for I<sup>2</sup>C monitoring
- High-Voltage FET Drivers**
  - Power supply ramp up/down control
  - Programmable current and voltage output
  - Independently configurable for FET control or digital output
- 2-Wire (I<sup>2</sup>C/SMBus™ Compatible) Interface**
  - Comparator status monitor
  - ADC readout
  - Direct control of inputs and outputs
  - Power sequence control
  - Dynamic trimming/margining control
- 3.3V Operation, Wide Supply Range 2.8V to 3.96V**
  - In-system programmable through JTAG
  - Industrial temperature range: -40°C to +85°C
  - 100-pin TQFP package, lead-free option

### Application Block Diagram

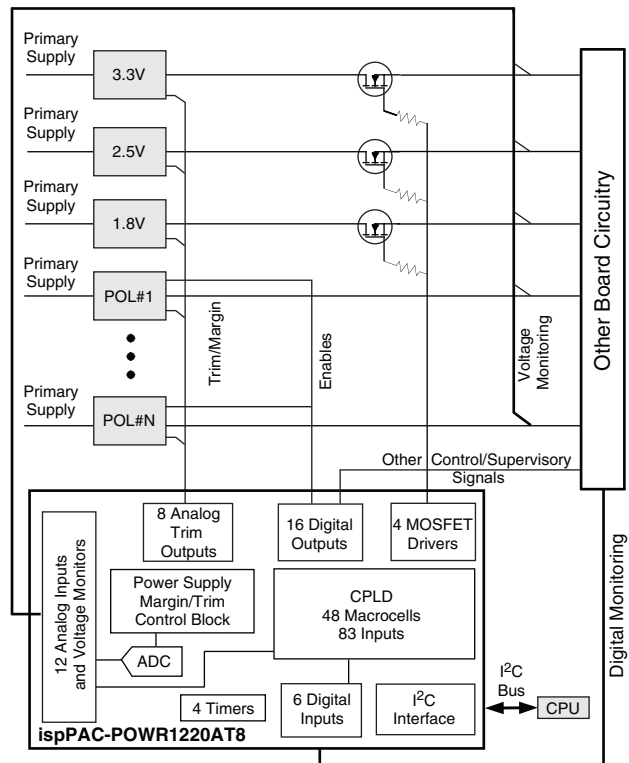

### Description

The Lattice Power Manager II ispPAC-POWR1220AT8 is a general-purpose power-supply monitor, sequence and margin controller, incorporating both in-system programmable logic and in-system programmable analog functions implemented in non-volatile E<sup>2</sup>CMOS® technology. The ispPAC-POWR1220AT8 device provides 12 independent analog input channels to monitor up to 12 power supply test points. Each of these input channels offers a differential input to support remote ground sensing, and has two independently programmable comparators to support both high/low and in-bounds/out-of-bounds (window-compare) monitor functions. Six general-purpose digital inputs are also provided for miscellaneous control functions.

The ispPAC-POWR1220AT8 provides 20 open-drain digital outputs that can be used for controlling DC-DC converters, low-drop-out regulators (LDOs) and opto-couplers, as well as for supervisory and general-purpose logic interface functions. Four of these outputs

© 2013 Lattice Semiconductor Corp. All Lattice trademarks, registered trademarks, patents, and disclaimers are as listed at [www.latticesemi.com/legal](http://www.latticesemi.com/legal). All other brand or product names are trademarks or registered trademarks of their respective holders. The specifications and information herein are subject to change without notice.

(HVOUT1-HVOUT4) may be configured as high-voltage MOSFET drivers. In high-voltage mode these outputs can provide up to 12V for driving the gates of n-channel MOSFETs so that they can be used as high-side power switches controlling the supplies with a programmable ramp rate for both ramp up and ramp down.

The ispPAC-POWR1220AT8 incorporates a 48-macrocell CPLD that can be used to implement complex state machine sequencing for the control of multiple power supplies as well as combinatorial logic functions. The status of all of the comparators on the analog input channels as well as the general purpose digital inputs are used as inputs by the CPLD array, and all digital outputs may be controlled by the CPLD. Four independently programmable timers can create delays and time-outs ranging from 32μs to 2 seconds. The CPLD is programmed using Logi-Builder™, an easy-to-learn language integrated into the PAC-Designer® software. Control sequences are written to monitor the status of any of the analog input channel comparators or the digital inputs.

In addition to the sequence control functions, the ispPAC-POWR1220AT8 incorporates eight DACs for generating trimming voltage to control the output voltage of a DC-DC converter. The trimming voltage can be set to four hardware selectable preset values (voltage profiles) or can be dynamically loaded in to the DAC through the I<sup>2</sup>C bus. Additionally, each power supply output voltage can be maintained typically within 0.5% tolerance across various load conditions using the Digital Closed Loop Control mode. The operating voltage profile can either be selected using external hardware pins or through the PLD outputs.

The on-chip 10-bit A/D converter can both be used to monitor the V<sub>MON</sub> voltage through the I<sup>2</sup>C bus as well as for implementing digital closed loop mode for maintaining the output voltage of all power supplies controlled by the monitoring and trimming section of the ispPAC-POWR1220AT8 device.

The I<sup>2</sup>C bus/SMBus interface allows an external microcontroller to measure the voltages connected to the V<sub>MON</sub> inputs, read back the status of each of the V<sub>MON</sub> comparator and PLD outputs, control logic signals IN2 to IN5, control the output pins, and load the DACs for the generation of the trimming voltage of the external DC-DC converter.

**Figure 1. ispPAC-POWR1220AT8 Block Diagram**

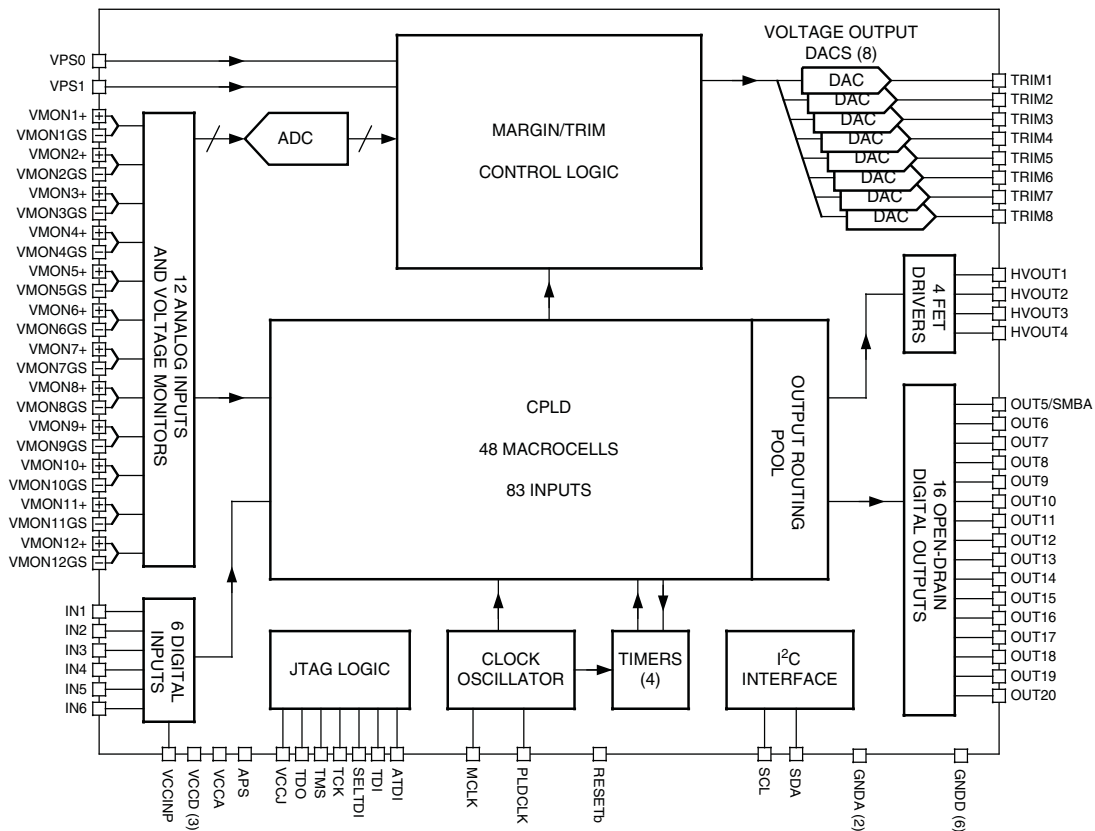

## Pin Descriptions

Number	Name	Pin Type	Voltage Range	Description
89	VPS0	Digital Input	VCCD	Trim Select Input 0 Registered by MCLK
90	VPS1	Digital Input	VCCD	Trim Select Input 1 Registered by MCLK
97	IN1 <sup>2</sup>	Digital Input	VCCINP <sup>1</sup>	PLD Logic Input 1 Registered by MCLK
1	IN2 <sup>3</sup>	Digital Input	VCCINP <sup>1</sup>	PLD Logic Input 2 Registered by MCLK
2	IN3 <sup>3</sup>	Digital Input	VCCINP <sup>1</sup>	PLD Logic Input 3 Registered by MCLK
4	IN4 <sup>3</sup>	Digital Input	VCCINP <sup>1</sup>	PLD Logic Input 4 Registered by MCLK
6	IN5 <sup>3</sup>	Digital Input	VCCINP <sup>1</sup>	PLD Logic Input 5 Registered by MCLK
7	IN6 <sup>3</sup>	Digital Input	VCCINP <sup>1</sup>	PLD Logic Input 6 Registered by MCLK
47	VMON1	Analog Input	-0.3V to 5.75V <sup>4</sup>	Voltage Monitor 1 Input
46	VMON1GS	Analog Input	-0.2V to 0.3V <sup>5</sup>	Voltage Monitor 1 Ground Sense
50	VMON2	Analog Input	-0.3V to 5.75V <sup>4</sup>	Voltage Monitor 2 Input
48	VMON2GS	Analog Input	-0.2V to 0.3V <sup>5</sup>	Voltage Monitor 2 Ground Sense
52	VMON3	Analog Input	-0.3V to 5.75V <sup>4</sup>	Voltage Monitor 3 Input
51	VMON3GS	Analog Input	-0.2V to 0.3V <sup>5</sup>	Voltage Monitor 3 Ground Sense
54	VMON4	Analog Input	-0.3V to 5.75V <sup>4</sup>	Voltage Monitor 4 Input
53	VMON4GS	Analog Input	-0.2V to 0.3V <sup>5</sup>	Voltage Monitor 4 Ground Sense
56	VMON5	Analog Input	-0.3V to 5.75V <sup>4</sup>	Voltage Monitor 5 Input
55	VMON5GS	Analog Input	-0.2V to 0.3V <sup>5</sup>	Voltage Monitor 5 Ground Sense
58	VMON6	Analog Input	-0.3V to 5.75V <sup>4</sup>	Voltage Monitor 6 Input
57	VMON6GS	Analog Input	-0.2V to 0.3V <sup>5</sup>	Voltage Monitor 6 Ground Sense
62	VMON7	Analog Input	-0.3V to 5.75V <sup>4</sup>	Voltage Monitor 7 Input
61	VMON7GS	Analog Input	-0.2V to 0.3V <sup>5</sup>	Voltage Monitor 7 Ground Sense
64	VMON8	Analog Input	-0.3V to 5.75V <sup>4</sup>	Voltage Monitor 8 Input
63	VMON8GS	Analog Input	-0.2V to 0.3V <sup>5</sup>	Voltage Monitor 8 Ground Sense
66	VMON9	Analog Input	-0.3V to 5.75V <sup>4</sup>	Voltage Monitor 9 Input
65	VMON9GS	Analog Input	-0.2V to 0.3V <sup>5</sup>	Voltage Monitor 9 Ground Sense
68	VMON10	Analog Input	-0.3V to 5.75V <sup>4</sup>	Voltage Monitor 10 Input
67	VMON10GS	Analog Input	-0.2V to 0.3V <sup>5</sup>	Voltage Monitor 10 Ground Sense
70	VMON11	Analog Input	-0.3V to 5.75V <sup>4</sup>	Voltage Monitor 11 Input
69	VMON11GS	Analog Input	-0.2V to 0.3V <sup>5</sup>	Voltage Monitor 11 Ground Sense
72	VMON12	Analog Input	-0.3V to 5.75V <sup>4</sup>	Voltage Monitor 12 Input
71	VMON12GS	Analog Input	-0.2V to 0.3V <sup>5</sup>	Voltage Monitor 12 Ground Sense
3, 22, 36, 43, 88, 98	GNDD <sup>8</sup>	Ground	Ground	Digital Ground
45, 87	GNDA <sup>8</sup>	Ground	Ground	Analog Ground
13, 38, 94	VCCD <sup>7</sup>	Power	2.8V to 3.96V	Core VCC, Main Power Supply
60	VCCA <sup>7</sup>	Power	2.8V to 3.96V	Analog Power Supply
5	VCCINP	Power	2.25V to 5.5V	VCC for IN[1:6] Inputs
33	VCCJ	Power	2.25V to 3.6V	VCC for JTAG Logic Interface Pins
39	APS <sup>10</sup>	Power	3.0V to 3.6V	VCC for E <sup>2</sup> Programming when the Device is <b>NOT</b> Powered by V <sub>CCD</sub> or V <sub>CCA</sub>
86	HVOUT1	Open Drain Output <sup>6</sup>	0V to 12V	Open-Drain Output 1
		Current Source/Sink	12.5µA to 100µA Source 100µA to 3000µA Sink	High-voltage FET Gate Driver 1

**Pin Descriptions (Cont.)**

Number	Name	Pin Type	Voltage Range	Description
85	HVOUT2	Open Drain Output <sup>6</sup>	0V to 12V	Open-Drain Output 2
		Current Source/Sink	12.5 $\mu$ A to 100 $\mu$ A Source 100 $\mu$ A to 3000 $\mu$ A Sink	High-voltage FET Gate Driver 2
42	HVOUT3	Open Drain Output <sup>6</sup>	0V to 12V	Open-Drain Output 3
		Current Source/Sink	12.5 $\mu$ A to 100 $\mu$ A Source 100 $\mu$ A to 3000 $\mu$ A Sink	High-voltage FET Gate Driver 3
40	HVOUT4	Open Drain Output <sup>6</sup>	0V to 12V	Open-Drain Output 4
		Current Source/Sink	12.5 $\mu$ A to 100 $\mu$ A Source 100 $\mu$ A to 3000 $\mu$ A Sink	High-voltage FET Gate Driver 4
8	OUT5_SMBA	Open Drain Output <sup>6</sup>	0V to 5.5V	Open-Drain Output 5, (SMBUS Alert Active Low)
9	OUT6	Open Drain Output <sup>6</sup>	0V to 5.5V	Open-Drain Output 6
10	OUT7	Open Drain Output <sup>6</sup>	0V to 5.5V	Open-Drain Output 7
11	OUT8	Open Drain Output <sup>6</sup>	0V to 5.5V	Open-Drain Output 8
12	OUT9	Open Drain Output <sup>6</sup>	0V to 5.5V	Open-Drain Output 9
14	OUT10	Open Drain Output <sup>6</sup>	0V to 5.5V	Open-Drain Output 10
15	OUT11	Open Drain Output <sup>6</sup>	0V to 5.5V	Open-Drain Output 11
16	OUT12	Open Drain Output <sup>6</sup>	0V to 5.5V	Open-Drain Output 12
17	OUT13	Open Drain Output <sup>6</sup>	0V to 5.5V	Open-Drain Output 13
18	OUT14	Open Drain Output <sup>6</sup>	0V to 5.5V	Open-Drain Output 14
19	OUT15	Open Drain Output <sup>6</sup>	0V to 5.5V	Open-Drain Output 15
20	OUT16	Open Drain Output <sup>6</sup>	0V to 5.5V	Open-Drain Output 16
21	OUT17	Open Drain Output <sup>6</sup>	0V to 5.5V	Open-Drain Output 17
23	OUT18	Open Drain Output <sup>6</sup>	0V to 5.5V	Open-Drain Output 18
24	OUT19	Open Drain Output <sup>6</sup>	0V to 5.5V	Open-Drain Output 19
25	OUT20	Open Drain Output <sup>6</sup>	0V to 5.5V	Open-Drain Output 20
84	TRIM1	Analog Output	-320mV to +320mV from Programmable DAC Offset	Trim DAC Output 1
83	TRIM2	Analog Output	-320mV to +320mV from Programmable DAC Offset	Trim DAC Output 2
82	TRIM3	Analog Output	-320mV to +320mV from Programmable DAC Offset	Trim DAC Output 3
80	TRIM4	Analog Output	-320mV to +320mV from Programmable DAC Offset	Trim DAC Output 4
79	TRIM5	Analog Output	-320mV to +320mV from Programmable DAC Offset	Trim DAC Output 5
75	TRIM6	Analog Output	-320mV to +320mV from Programmable DAC Offset	Trim DAC Output 6
74	TRIM7	Analog Output	-320mV to +320mV from Programmable DAC Offset	Trim DAC Output 7

## Pin Descriptions (Cont.)

Number	Name	Pin Type	Voltage Range	Description
73	TRIM8	Analog Output	-320mV to +320mV from Programmable DAC Offset	Trim DAC Output 8
91	RESETb <sup>9</sup>	Digital I/O	0V to 3.96V	Device Reset (Active Low)
95	PLDCLK	Digital Output	0V to 3.96V	250kHz PLD Clock Output (Tristate), CMOS Output
96	MCLK	Digital I/O	0V to 3.96V	8MHz Clock I/O (Tristate), CMOS Drive
34	TDO	Digital Output	0V to 5.5V	JTAG Test Data Out
37	TCK	Digital Input	0V to 5.5V	JTAG Test Clock Input
28	TMS	Digital Input	0V to 5.5V	JTAG Test Mode Select
31	TDI	Digital Input	0V to 5.5V	JTAG Test Data In, TDISEL pin = 1
30	ATDI	Digital Input	0V to 5.5V	JTAG Test Data In (Alternate), TDISEL Pin = 0
32	TDISEL	Digital Input	0V to 5.5V	Select TDI/ATDI Input
92	SCL	Digital Input	0V to 5.5V	I <sup>2</sup> C Serial Clock Input
93	SDA	Digital I/O	0V to 5.5V	I <sup>2</sup> C Serial Data, Bi-directional Pin
44, 59	RESERVED			Reserved - Do Not Connect
26, 27, 29, 35, 41, 49, 76, 77, 78, 81, 99, 100	NC			No Internal Connection

- [IN1...IN6] are inputs to the PLD. The thresholds for these pins are referenced by the voltage on VCCINP.
- IN1 pin can also be controlled through JTAG interface.
- [IN2...IN6] can also be controlled through I<sup>2</sup>C/SMBus interface.
- The VMON inputs can be biased independently from VCCA. Unused VMONs should be tied to GNDD.
- The VMONGS inputs are the ground sense line for each given VMON pin. The VMON input pins along with the VMONGS ground sense pins implement a differential pair for each voltage monitor to allow remote sense at the load. VMONGS lines must be connected and are not to exceed -0.2V - +0.3V in reference to the GNDA pin.
- Open-drain outputs require an external pull-up resistor to a supply.
- VCCD and VCCA pins must be connected together on the circuit board.
- GNDA and GNDD pins must be connected together on the circuit board.
- The RESETb pin should only be used for cascading two or more ispPAC-POWR1220AT8 devices.
- The APS pin **MUST** be left floating when VCCD and VCCA are powered.

## Absolute Maximum Ratings

Absolute maximum ratings are shown in the table below. Stresses beyond those listed may cause permanent damage to the device. Functional operation of the device at these or any other conditions beyond those indicated in the recommended operating conditions of this specification is not implied.

Symbol	Parameter	Conditions	Min.	Max.	Units
V <sub>CCD</sub>	Core supply		-0.5	4.5	V
V <sub>CCA</sub>	Analog supply		-0.5	4.5	V
V <sub>CCINP</sub>	Digital input supply (IN[1:6])		-0.5	6	V
V <sub>CCJ</sub>	JTAG logic supply		-0.5	6	V
APS <sup>1</sup>	Alternate E <sup>2</sup> programming supply <sup>1</sup>		-0.5	4	V
V <sub>IN</sub>	Digital input voltage (all digital I/O pins)		-0.5	6	V
V <sub>MON+</sub>	V <sub>MON</sub> input voltage		-0.5	6	V
V <sub>MONGS</sub>	V <sub>MON</sub> input voltage ground sense		-0.5	6	V
V <sub>TRI</sub>	Voltage applied to tri-stated pins	HVOUT[1:4]	-0.5	13.3	V
		OUT[5:20]	-0.5	6	V
I <sub>SINKMAXTOTAL</sub>	Maximum sink current on any output			23	mA
T <sub>S</sub>	Storage temperature		-65	150	°C
T <sub>A</sub>	Ambient temperature		-65	125	°C

1. The APS pin **MUST** be left floating when V<sub>CCD</sub> and V<sub>CCA</sub> are powered.

## Recommended Operating Conditions

Symbol	Parameter	Conditions	Min.	Max.	Units
V <sub>CCD</sub> , V <sub>CCA</sub>	Core supply voltage at pin		2.8	3.96	V
V <sub>CCINP</sub>	Digital input supply for IN[1:6] at pin		2.25	5.5	V
V <sub>CCJ</sub>	JTAG logic supply voltage at pin		2.25	3.6	V
APS	Alternate E <sup>2</sup> programming supply at pin	V <sub>CCD</sub> and V <sub>CCA</sub> powered	No Connect Must Be Left Floating		
		V <sub>CCD</sub> and V <sub>CCA</sub> not powered	3.0	3.6	V
V <sub>IN</sub>	Input voltage at digital input pins		-0.3	5.5	V
V <sub>MON</sub>	Input voltage at V <sub>MON</sub> pins		-0.3	5.9	V
V <sub>MONGS</sub>	Input voltage at V <sub>MONGS</sub> pins		-0.2	0.3	V
V <sub>OUT</sub>	Open-drain output voltage	OUT[5:20] pins	-0.3	5.5	V
		HVOUT[1:4] pins in open-drain mode	-0.3	13.0	V
T <sub>A</sub> PROG	Ambient temperature during programming		-40	85	°C
T <sub>A</sub>	Ambient temperature	Power applied	-40	85	°C

## ESD Performance

Pin Group	ESD Stress	Min.	Units
All pins	HBM	2000	V
	CDM	1000	V

## Analog Specifications

Symbol	Parameter	Conditions	Min.	Typ.	Max.	Units
$I_{CC}^1$	Supply current				40	mA
$I_{CCINP}$	Supply current				5	mA
$I_{CCJ}$	Supply current				1	mA
$I_{CCPROG}$	Supply current	During programming cycle			40	mA

1. Includes currents on  $V_{CCD}$  and  $V_{CCA}$  supplies.

## Voltage Monitors

Symbol	Parameter	Conditions	Min.	Typ.	Max.	Units
$R_{IN}$	Input resistance		55	65	75	$k\Omega$
$C_{IN}$	Input capacitance			8		pF
$V_{MON}$ Range	Programmable trip-point range		0.075		5.734	V
$V_Z$ Sense	Near-ground sense threshold		70	75	80	mV
$V_{MON}$ Accuracy	Absolute accuracy of any trip-point <sup>1</sup>			0.2	0.7	%
HYST	Hysteresis of any trip-point (relative to setting)			1		%
CMR	Common mode rejection			60		dB

1. Guaranteed by characterization across  $V_{CCA}$  range, operating temperature, process.

## High Voltage FET Drivers

Symbol	Parameter	Conditions	Min.	Typ.	Max.	Units
$V_{PP}$	Gate driver output voltage	12V setting <sup>1</sup>	11.5	12	12.5	V
		10V setting	9.6	10	10.4	
		8V setting	7.7	8	8.3	
		6V setting	5.8	6	6.2	
$I_{OUTSRC}$	Gate driver source current (HIGH state)	Four settings in software		12.5		$\mu A$
				25		
				50		
				100		
$I_{OUTSINK}$	Gate driver sink current (LOW state)	FAST OFF mode	2000	3000		$\mu A$
		Controlled ramp settings		100		
				250		
				500		

1. 12V setting only available on the ispPAC-POWR1220AT8-02.

## Margin/Trim DAC Output Characteristics

Symbol	Parameter	Conditions	Min	Typ	Max	Units
	Resolution			8(7+sign)		bits
FSR	Full scale range			+/-320		mV
LSB	LSB step size			2.5		mV
I <sub>OUT</sub>	Output source/sink current		-200		200	μA
BPZ	Bipolar zero output voltage (code=80h)	Offset 1		0.6		V
		Offset 2		0.8		
		Offset 3		1.0		
		Offset 4		1.25		
TS	TrimCell output voltage settling time <sup>1</sup>	DAC code changed from 80H to FFH or 80H to 00H			2.5	ms
		Single DAC code change		256		μs
C_LOAD	Maximum load capacitance				50	pF
T <sub>UPDATEM</sub>	Update time through I <sup>2</sup> C port <sup>2</sup>	MCLK = 8MHz		260		μs
TOSE	Total open loop supply voltage error <sup>3</sup>	Full scale DAC corresponds to ±5% supply voltage variation	-1%		+1%	V/V

1. To 1% of set value with 50pf load connected to trim pins.

2. Total time required to update a single TRIMx output value by setting the associated DAC through the I<sup>2</sup>C port.

3. This is the total resultant error in the trimmed power supply output voltage referred to any DAC code due to the DAC's INL, DNL, gain, output impedance, offset error and bipolar offset error across the industrial temperature range and the ispPAC-POWR1200AT8 operating V<sub>CCA</sub> and V<sub>CCD</sub> ranges.

## ADC Characteristics

Symbol	Parameter	Conditions	Min.	Typ.	Max.	Units
	ADC Resolution			10		Bits
T <sub>CONVERT</sub>	Conversion Time	Time from I <sup>2</sup> C Request			200	μs
V <sub>IN</sub>	Input range Full Scale	Programmable Attenuator = 1	0		2.048	V
		Programmable Attenuator = 3	0		5.9 <sup>1</sup>	V
ADC Step Size	LSB	Programmable Attenuator = 1		2		mV
		Programmable Attenuator = 3		6		mV
E <sub>attenuator</sub>	Error Due to Attenuator	Programmable Attenuator = 3		+/- 0.1		%

1. Maximum voltage is limited by V<sub>MONX</sub> pin (theoretical maximum is 6.144V).

## ADC Error Budget Across Entire Operating Temperature Range

Symbol	Parameter	Conditions	Min.	Typ.	Max.	Units
TADC Error	Total Measurement Error at Any Voltage <sup>1</sup>	Measurement Range 600 mV - 2.048V, VMONxGS > -100mV, Attenuator =1	-8	+/-4	8	mV
		Measurement Range 600 mV - 2.048V, VMONxGS > -200mV, Attenuator =1		+/-6		mV
		Measurement Range 0 - 600 mV, VMONxGS > -200mV, Attenuator =1		+/-10		mV

1. Total error, guaranteed by characterization, includes INL, DNL, Gain, Offset, and PSR specs of the ADC.

## Power-On Reset

Symbol	Parameter	Conditions	Min.	Typ.	Max.	Units
$T_{RST}$	Delay from $V_{TH}$ to start-up state				100	$\mu s$
$T_{START}$	Delay from RESETb HIGH to PLDCLK rising edge			5	10	$\mu s$
$T_{GOOD}$	Power-on reset to valid VMON comparator output and AGOOD is true				2.5	ms
$T_{BRO}$	Minimum duration brown out required to trigger RESETb		1		5	$\mu s$
$T_{POR}$	Delay from brown out to reset state.				13	$\mu s$
$V_{TL}$	Threshold below which RESETb is LOW <sup>1</sup>				2.3	V
$V_{TH}$	Threshold above which RESETb is HIGH <sup>1</sup>		2.7			V
$V_T$	Threshold above which RESETb is valid <sup>1</sup>		0.8			V
$C_L$	Capacitive load on RESETb for master/slave operation				200	pF

1. Corresponds to VCCA and VCCD supply voltages.

**Figure 2. ispPAC-POWR1220ATE Power-On Reset**

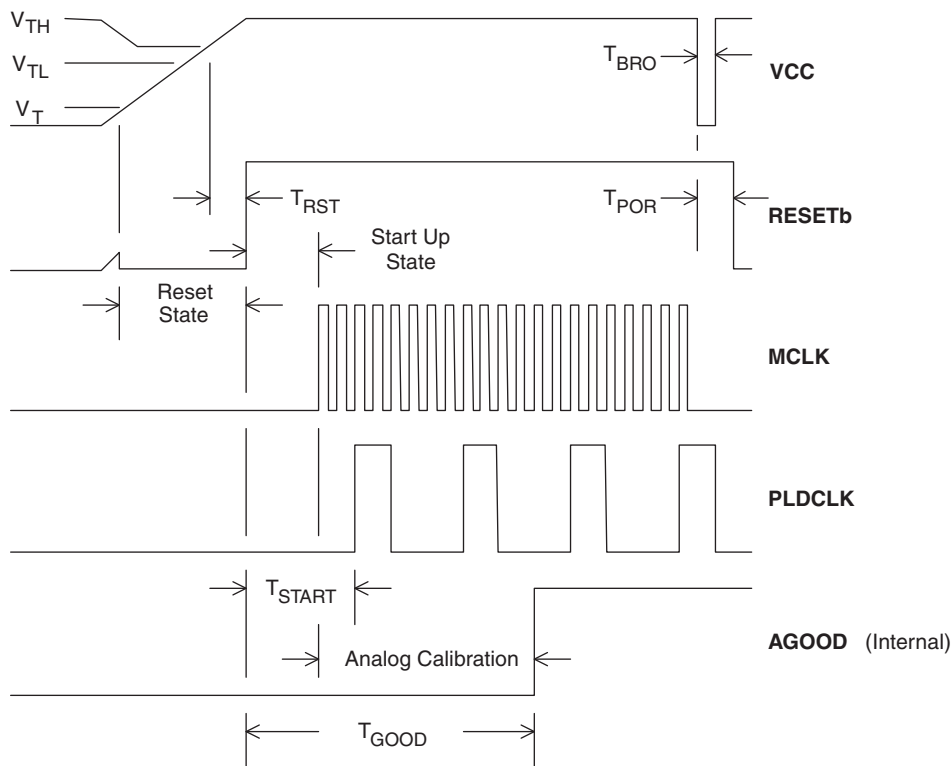

## AC/Transient Characteristics

### Over Recommended Operating Conditions

Symbol	Parameter	Conditions	Min.	Typ.	Max.	Units
<b>Voltage Monitors</b>						
$t_{PD16}$	Propagation delay input to output glitch filter OFF			16		$\mu$ s
$t_{PD64}$	Propagation delay input to output glitch filter ON			64		$\mu$ s
<b>Oscillators</b>						
$f_{CLK}$	Internal master clock frequency (MCLK)		7.6	8	8.4	MHz
$f_{CLKEXT}$	Externally applied master clock (MCLK)		7.2		8.8	MHz
$f_{PLDCLK}$	PLDCLK output frequency	$f_{CLK} = 8\text{MHz}$		250		kHz
<b>Timers</b>						
Timeout Range	Range of programmable timers (128 steps)	$f_{CLK} = 8\text{MHz}$	0.032		1966	ms
Resolution	Spacing between available adjacent timer intervals				13	%
Accuracy	Timer accuracy	$f_{CLK} = 8\text{MHz}$	-6.67		-12.5	%

## Digital Specifications

### Over Recommended Operating Conditions

Symbol	Parameter	Conditions	Min.	Typ.	Max.	Units
$I_{IL}, I_{IH}$	Input leakage, no pull-up/pull-down				+/-10	$\mu\text{A}$
$I_{OH-HVOUT}$	Output leakage current	HVOUT[1:4] in open drain mode and pulled up to 12V		35	60	$\mu\text{A}$
$I_{PU}$	Input pull-up current (TMS, TDI, TDISEL, ATDI, MCLK)			70		$\mu\text{A}$
$V_{IL}$	Voltage input, logic low <sup>1</sup>	VPS[0:1], TDI, TMS, ATDI, TDISEL, 3.3V supply			0.8	V
		VPS[0:1], TDI, TMS, ATDI, TDISEL, 2.5V supply			0.7	
		SCL, SDA			30% $V_{CCD}$	
		IN[1:6]			30% $V_{CCINP}$	
$V_{IH}$	Voltage input, logic high <sup>1</sup>	VPS[0:1], TDI, TMS, ATDI, TDISEL, 3.3V supply	2.0			V
		VPS[0:1], TDI, TMS, ATDI, TDISEL, 2.5V supply	1.7			
		SCL, SDA	70% $V_{CCD}$		$V_{CCD}$	
		IN[1:6]	70% $V_{CCINP}$		$V_{CCINP}$	
$V_{OL}$	HVOUT[1:4] (open drain mode),	$I_{SINK} = 10\text{mA}$			0.8	V
	OUT[5:20]	$I_{SINK} = 20\text{mA}$			0.8	
	TDO, MCLK, PLDCLK, SDA	$I_{SINK} = 4\text{mA}$			0.4	
$V_{OH}$	TDO, MCLK, PLDCLK	$I_{SRC} = 4\text{mA}$			$V_{CCD} - 0.4$	V
$I_{SINKTOTAL}$	All digital outputs				130	mA

1. VPS[0:1], SCL, SDA referenced to  $V_{CCD}$ ; IN[1:6] referenced to  $V_{CCINP}$ ; TDO, TDI, TMS, ATDI, TDISEL referenced to  $V_{CCJ}$ .

## I<sup>2</sup>C Port Characteristics

Symbol	Definition	100KHz		400KHz		Units
		Min.	Max.	Min.	Max.	
F <sub>I<sup>2</sup>C</sub>	I <sup>2</sup> C clock/data rate		100 <sup>1</sup>		400 <sup>1</sup>	KHz
T <sub>SU;STA</sub>	After start	4.7		0.6		us
T <sub>HD;STA</sub>	After start	4		0.6		us
T <sub>SU;DAT</sub>	Data setup	250		100		ns
T <sub>SU;STO</sub>	Stop setup	4		0.6		us
T <sub>HD;DAT</sub>	Data hold; SCL= Vih_min = 2.1V	0.3	3.45	0.3	0.9	us
T <sub>LOW</sub>	Clock low period	4.7		1.3		us
T <sub>HIGH</sub>	Clock high period	4		0.6		us
T <sub>F</sub>	Fall time; 2.25V to 0.65V		300		300	ns
T <sub>R</sub>	Rise time; 0.65V to 2.25V		1000		300	ns
T <sub>TIMEOUT</sub>	Detect clock low timeout	25	35	25	35	ms
T <sub>POR</sub>	Device must be operational after power-on reset	500		500		ms
T <sub>BUF</sub>	Bus free time between stop and start condition	4.7		1.3		us

1. If F<sub>I<sup>2</sup>C</sub> is less than 50kHz, then the ADC DONE status bit is not guaranteed to be set after a valid conversion request is completed. In this case, waiting for the T<sub>CONVERT</sub> minimum time after a convert request is made is the only way to guarantee a valid conversion is ready for readout. When F<sub>I<sup>2</sup>C</sub> is greater than 50kHz, ADC conversion complete is ensured by waiting for the DONE status bit.

## Timing for JTAG Operations

Symbol	Parameter	Conditions	Min.	Typ.	Max.	Units
$t_{\text{SPEN}}$	Program enable delay time		10	—	—	$\mu\text{s}$
$t_{\text{SPDIS}}$	Program disable delay time		30	—	—	$\mu\text{s}$
$t_{\text{HVDIS}}$	High voltage discharge time, program		30	—	—	$\mu\text{s}$
$t_{\text{HVDIS}}$	High voltage discharge time, erase		200	—	—	$\mu\text{s}$
$t_{\text{CEN}}$	Falling edge of TCK to TDO active		—	—	15	ns
$t_{\text{CDIS}}$	Falling edge of TCK to TDO disable		—	—	15	ns
$t_{\text{SU1}}$	Setup time		5	—	—	ns
$t_{\text{H}}$	Hold time		10	—	—	ns
$t_{\text{CKH}}$	TCK clock pulse width, high		20	—	—	ns
$t_{\text{CKL}}$	TCK clock pulse width, low		20	—	—	ns
$f_{\text{MAX}}$	Maximum TCK clock frequency		—	—	25	MHz
$t_{\text{CO}}$	Falling edge of TCK to valid output		—	—	15	ns
$t_{\text{PWV}}$	Verify pulse width		30	—	—	$\mu\text{s}$
$t_{\text{PWP}}$	Programming pulse width		20	—	—	ms

Figure 3. Erase (User Erase or Erase All) Timing Diagram

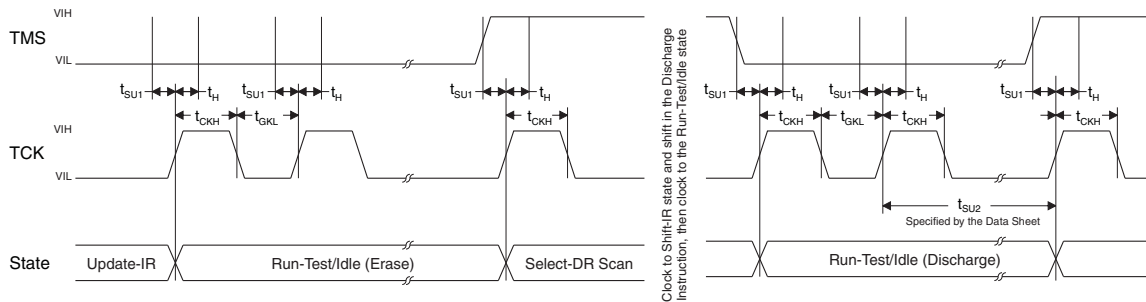

Figure 4. Programming Timing Diagram

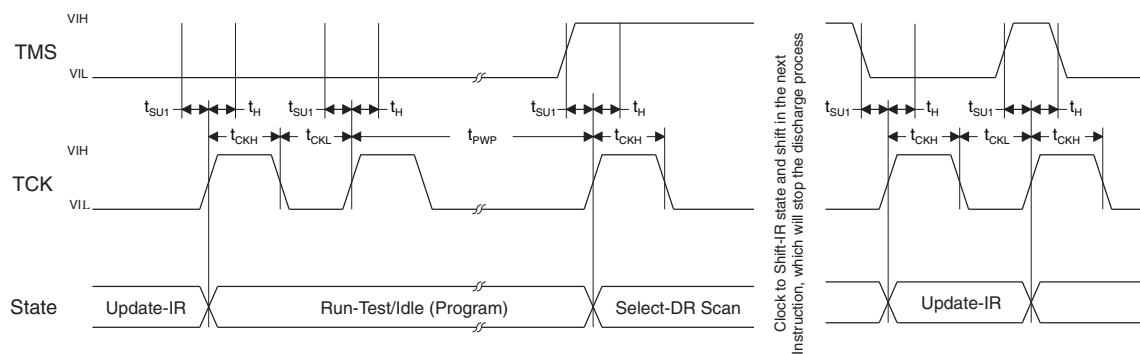

Figure 5. Verify Timing Diagram

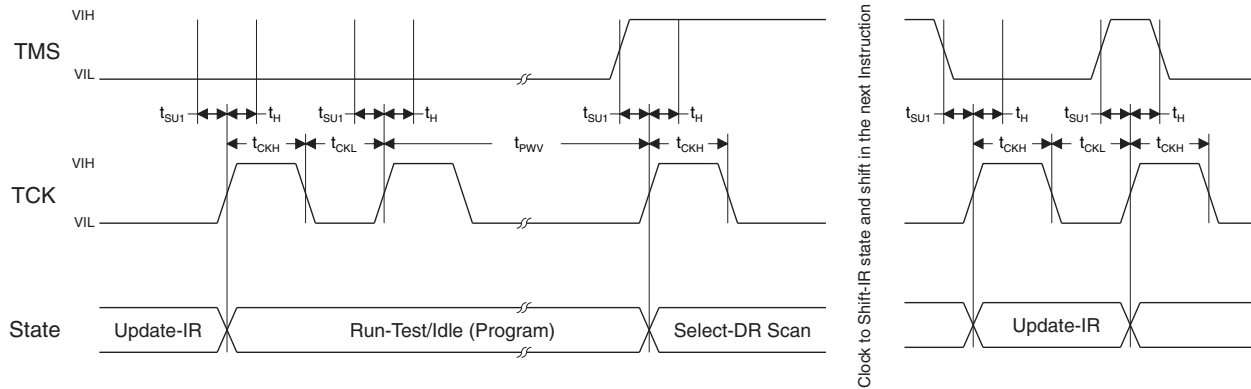
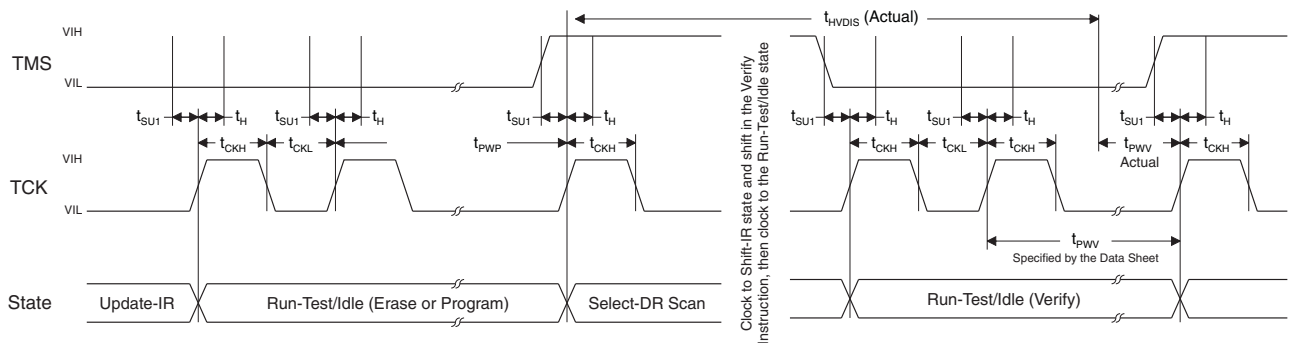

Figure 6. Discharge Timing Diagram



## Theory of Operation

### Analog Monitor Inputs

The ispPAC-POWR1220AT8 provides 12 independently programmable voltage monitor input circuits as shown in Figure 7. Two individually programmable trip-point comparators are connected to an analog monitoring input. Each comparator reference has 368 programmable trip points over the range of 0.664V to 5.734V. Additionally, a 75mV 'zero-detect' threshold is selectable which allows the voltage monitors to determine if a monitored signal has dropped to ground level. This feature is especially useful for determining if a power supply's output has decayed to a substantially inactive condition after it has been switched off.

Figure 7. ispPAC-POWR1220AT8 Voltage Monitors

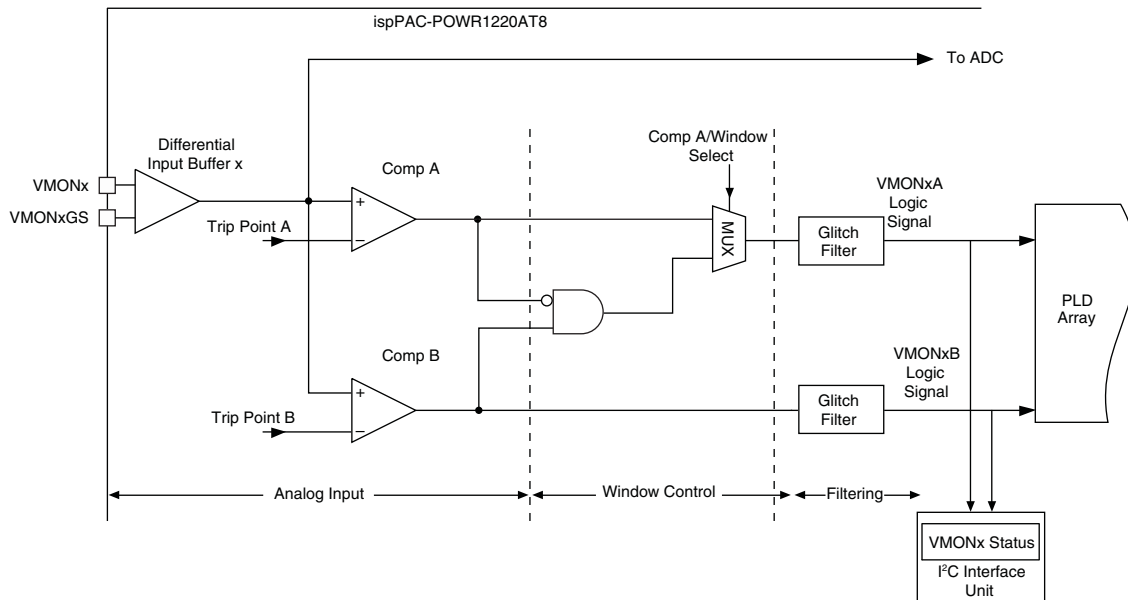

Figure 7 shows the functional block diagram of one of the 12 voltage monitor inputs - 'x' (where  $x = 1 \dots 12$ ). Each voltage monitor can be divided into three sections: Analog Input, Window Control, and Filtering. The first section provides a differential input buffer to monitor the power supply voltage through VMONx+ (to sense the positive terminal of the supply) and VMONxGS (to sense the power supply ground). Differential voltage sensing minimizes inaccuracies in voltage measurement with ADC and monitor thresholds due to the potential difference between the ispPAC-POWR1220AT8 device ground and the ground potential at the sensed node on the circuit board.

The voltage output of the differential input buffer is monitored by two individually programmable trip-point comparators, shown as CompA and CompB. Table 1 shows all 368 trip points spanning the range 0.664V to 5.734V to which a comparator's threshold can be set.

Each comparator outputs a HIGH signal to the PLD array if the voltage at its positive terminal is greater than its programmed trip point setting, otherwise it outputs a LOW signal.

A hysteresis of approximately 1% of the setpoint is provided by the comparators to reduce false triggering as a result of input noise. The hysteresis provided by the voltage monitor is a function of the input divider setting. Table 3 lists the typical hysteresis versus voltage monitor trip-point.

### AGOOD Logic Signal

All the VMON comparators auto-calibrate immediately after a power-on reset event. During this time, the digital glitch filters are also initialized. This process completion is signalled by an internally generated logic signal: AGOOD. All logic using the VMON comparator logic signals must wait for the AGOOD signal to become active.

### Programmable Over-Voltage and Under-Voltage Thresholds

Figure 8 (a) shows the power supply ramp-up and ramp-down voltage waveforms. Because of hysteresis, the comparator outputs change state at different thresholds depending on the direction of excursion of the monitored power supply.

**Figure 8. (a) Power Supply Voltage Ramp-up and Ramp-down Waveform and the Resulting Comparator Output, (b) Corresponding to Upper and Lower Trip Points**

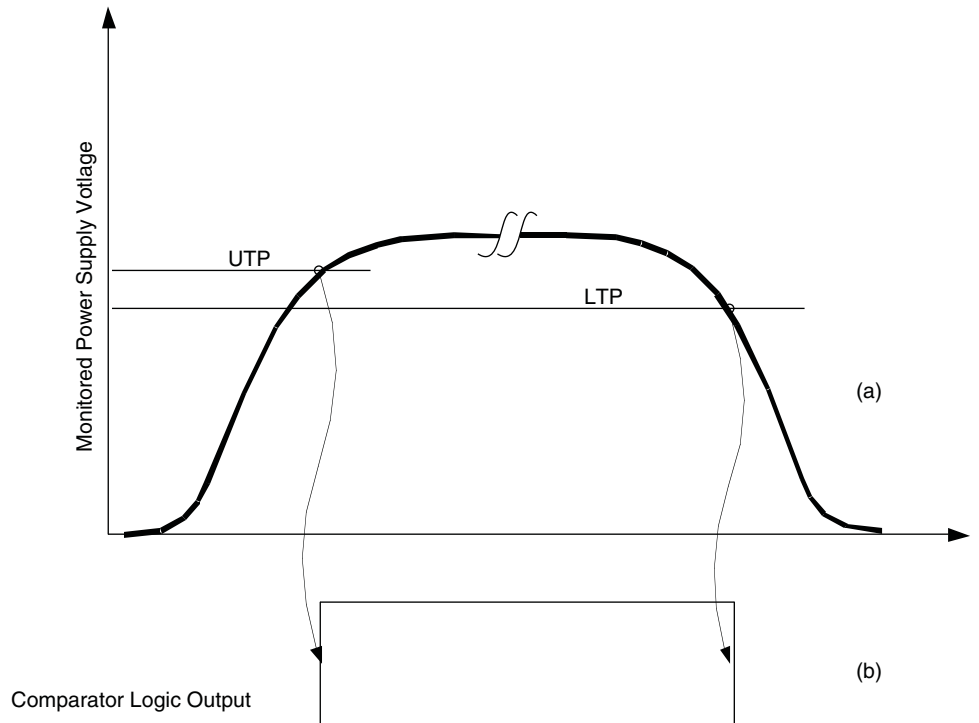

During power supply ramp-up the comparator output changes from logic 0 to 1 when the power supply voltage crosses the upper trip point (UTP). During ramp down the comparator output changes from logic state 1 to 0 when the power supply voltage crosses the lower trip point (LTP). To monitor for over voltage fault conditions, the UTP should be used. To monitor under-voltage fault conditions, the LTP should be used.

Tables 1 and 2 show both the under-voltage and over-voltage trip points, which are automatically selected in software depending on whether the user is monitoring for an over-voltage condition or an under-voltage condition.

**Table 1. Trip Point Table Used For Over-Voltage Detection**

Fine Range Setting	Coarse Range Setting											
	1	2	3	4	5	6	7	8	9	10	11	12
1	0.790	0.941	1.120	1.333	1.580	1.885	2.244	2.665	3.156	3.758	4.818	5.734
2	0.786	0.936	1.114	1.326	1.571	1.874	2.232	2.650	3.139	3.738	4.792	5.703
3	0.782	0.930	1.108	1.319	1.563	1.864	2.220	2.636	3.123	3.718	4.766	5.674
4	0.778	0.926	1.102	1.312	1.554	1.854	2.209	2.622	3.106	3.698	4.741	5.643
5	0.773	0.921	1.096	1.305	1.546	1.844	2.197	2.607	3.089	3.678	4.715	5.612
6	0.769	0.916	1.090	1.298	1.537	1.834	2.185	2.593	3.072	3.657	4.689	5.581
7	0.765	0.911	1.084	1.290	1.529	1.825	2.173	2.579	3.056	3.637	4.663	5.550
8	0.761	0.906	1.078	1.283	1.520	1.815	2.161	2.565	3.039	3.618	4.638	5.520
9	0.756	0.901	1.072	1.276	1.512	1.805	2.149	2.550	3.022	3.598	4.612	5.489
10	0.752	0.896	1.066	1.269	1.503	1.795	2.137	2.536	3.005	3.578	4.586	5.459
11	0.748	0.891	1.060	1.262	1.495	1.785	2.125	2.522	2.988	3.558	4.561	5.428
12	0.744	0.886	1.054	1.255	1.486	1.774	2.113	2.507	2.971	3.537	4.535	5.397
13	0.739	0.881	1.048	1.248	1.478	1.764	2.101	2.493	2.954	3.517	4.509	5.366
14	0.735	0.876	1.042	1.240	1.470	1.754	2.089	2.479	2.937	3.497	4.483	5.336
15	0.731	0.871	1.036	1.233	1.461	1.744	2.077	2.465	2.920	3.477	4.457	5.305
16	0.727	0.866	1.030	1.226	1.453	1.734	2.064	2.450	2.903	3.457	4.431	5.274
17	0.723	0.861	1.024	1.219	1.444	1.724	2.052	2.436	2.886	3.437	4.406	5.244
18	0.718	0.856	1.018	1.212	1.436	1.714	2.040	2.422	2.869	3.416	4.380	5.213
19	0.714	0.851	1.012	1.205	1.427	1.704	2.028	2.407	2.852	3.396	4.355	5.183
20	0.710	0.846	1.006	1.198	1.419	1.694	2.016	2.393	2.836	3.376	4.329	5.152
21	0.706	0.841	1.000	1.190	1.410	1.684	2.004	2.379	2.819	3.356	4.303	5.121
22	0.701	0.836	0.994	1.183	1.402	1.673	1.992	2.365	2.802	3.336	4.277	5.090
23	0.697	0.831	0.988	1.176	1.393	1.663	1.980	2.350	2.785	3.316	4.251	5.059
24	0.693	0.826	0.982	1.169	1.385	1.653	1.968	2.337	2.768	3.296	4.225	5.030
25	0.689	0.821	0.976	1.162	1.376	1.643	1.956	2.323	2.752	3.276	4.199	4.999
26	0.684	0.816	0.970	1.155	1.369	1.633	1.944	2.309	2.735	3.256	4.174	4.968
27	0.680	0.810	0.964	1.148	1.361	1.623	1.932	2.294	2.718	3.236	4.149	4.937
28	0.676	0.805	0.958	1.140	1.352	1.613	1.920	2.280	2.701	3.216	4.123	4.906
29	0.672	0.800	0.952	1.133	1.344	1.603	1.908	2.266	2.684	3.196	4.097	4.876
30	0.668	0.795	0.946	1.126	—	1.593	1.896	2.251	—	3.176	4.071	4.845
Low-V Sense	75mV											

**Table 2. Trip Point Table Used For Under-Voltage Detection**

Fine Range Setting	Coarse Range Setting											
	1	2	3	4	5	6	7	8	9	10	11	12
1	0.786	0.936	1.114	1.326	1.571	1.874	2.232	2.650	3.139	3.738	4.792	5.703
2	0.782	0.930	1.108	1.319	1.563	1.864	2.220	2.636	3.123	3.718	4.766	5.674
3	0.778	0.926	1.102	1.312	1.554	1.854	2.209	2.622	3.106	3.698	4.741	5.643
4	0.773	0.921	1.096	1.305	1.546	1.844	2.197	2.607	3.089	3.678	4.715	5.612
5	0.769	0.916	1.090	1.298	1.537	1.834	2.185	2.593	3.072	3.657	4.689	5.581
6	0.765	0.911	1.084	1.290	1.529	1.825	2.173	2.579	3.056	3.637	4.663	5.550
7	0.761	0.906	1.078	1.283	1.520	1.815	2.161	2.565	3.039	3.618	4.638	5.520
8	0.756	0.901	1.072	1.276	1.512	1.805	2.149	2.550	3.022	3.598	4.612	5.489
9	0.752	0.896	1.066	1.269	1.503	1.795	2.137	2.536	3.005	3.578	4.586	5.459
10	0.748	0.891	1.060	1.262	1.495	1.785	2.125	2.522	2.988	3.558	4.561	5.428
11	0.744	0.886	1.054	1.255	1.486	1.774	2.113	2.507	2.971	3.537	4.535	5.397
12	0.739	0.881	1.048	1.248	1.478	1.764	2.101	2.493	2.954	3.517	4.509	5.366
13	0.735	0.876	1.042	1.240	1.470	1.754	2.089	2.479	2.937	3.497	4.483	5.336
14	0.731	0.871	1.036	1.233	1.461	1.744	2.077	2.465	2.920	3.477	4.457	5.305
15	0.727	0.866	1.030	1.226	1.453	1.734	2.064	2.450	2.903	3.457	4.431	5.274
16	0.723	0.861	1.024	1.219	1.444	1.724	2.052	2.436	2.886	3.437	4.406	5.244
17	0.718	0.856	1.018	1.212	1.436	1.714	2.040	2.422	2.869	3.416	4.380	5.213
18	0.714	0.851	1.012	1.205	1.427	1.704	2.028	2.407	2.852	3.396	4.355	5.183
19	0.710	0.846	1.006	1.198	1.419	1.694	2.016	2.393	2.836	3.376	4.329	5.152
20	0.706	0.841	1.000	1.190	1.410	1.684	2.004	2.379	2.819	3.356	4.303	5.121
21	0.701	0.836	0.994	1.183	1.402	1.673	1.992	2.365	2.802	3.336	4.277	5.090
22	0.697	0.831	0.988	1.176	1.393	1.663	1.980	2.350	2.785	3.316	4.251	5.059
23	0.693	0.826	0.982	1.169	1.385	1.653	1.968	2.337	2.768	3.296	4.225	5.030
24	0.689	0.821	0.976	1.162	1.376	1.643	1.956	2.323	2.752	3.276	4.199	4.999
25	0.684	0.816	0.970	1.155	1.369	1.633	1.944	2.309	2.735	3.256	4.174	4.968
26	0.680	0.810	0.964	1.148	1.361	1.623	1.932	2.294	2.718	3.236	4.149	4.937
27	0.676	0.805	0.958	1.140	1.352	1.613	1.920	2.280	2.701	3.216	4.123	4.906
28	0.672	0.800	0.952	1.133	1.344	1.603	1.908	2.266	2.684	3.196	4.097	4.876
29	0.668	0.795	0.946	1.126	1.335	1.593	1.896	2.251	2.667	3.176	4.071	4.845
30	0.664	0.790	0.940	1.119	—	1.583	1.884	2.236	—	3.156	4.045	4.815
Low-V Sense	75mV											

**Table 3. Comparator Hysteresis vs. Trip-Point**

Trip-point Range (V)		Hysteresis (mV)
Low Limit	High Limit	
0.664	0.79	8
0.79	0.941	10
0.94	1.12	12
1.119	1.333	14
1.326	1.58	17
1.583	1.885	20
1.884	2.244	24
2.236	2.665	28
2.65	3.156	34
3.156	3.758	40
4.045	4.818	51
4.815	5.734	61
75 mV		0 (Disabled)

The window control section of the voltage monitor circuit is an AND gate (with inputs: an inverted COMPA “ANDed” with COMPB signal) and a multiplexer that supports the ability to develop a ‘window’ function without using any of the PLD’s resources. Through the use of the multiplexer, voltage monitor’s ‘A’ output may be set to report either the status of the ‘A’ comparator, or the window function of both comparator outputs. The voltage monitor’s ‘A’ output indicates whether the input signal is between or outside the two comparator thresholds. **Important:** This windowing function is only valid in cases where the threshold of the ‘A’ comparator is set to a value higher than that of the ‘B’ comparator. Table 4 shows the operation of window function logic.

**Table 4. Voltage Monitor Windowing Logic**

Input Voltage	Comp A	Comp B	Window (B and Not A)	Comment
$V_{IN} < \text{Trip-point B} < \text{Trip-point A}$	0	0	0	Outside window, low
$\text{Trip-point B} < V_{IN} < \text{Trip-point A}$	0	1	1	Inside window
$\text{Trip-point B} < \text{Trip-point A} < V_{IN}$	1	1	0	Outside window, high

Note that when the ‘A’ output of the voltage monitor circuit is set to windowing mode, the ‘B’ output continues to monitor the output of the ‘B’ comparator. This can be useful in that the ‘B’ output can be used to augment the windowing function by determining if the input is above or below the windowing range.

The third section in the ispPAC-POWR1220AT8’s input voltage monitor is a digital filter. When enabled, the comparator output will be delayed by a filter time constant of 64  $\mu\text{S}$ , and is especially useful for reducing the possibility of false triggering from noise that may be present on the voltages being monitored. When the filter is disabled, the comparator output will be delayed by 16 $\mu\text{S}$ . In both cases, enabled or disabled, the filters also provide synchronization of the input signals to the PLD clock. This synchronous sampling feature effectively eliminates the possibility of race conditions from occurring in any subsequent logic that is implemented in the ispPAC-POWR1220AT8’s internal PLD logic.

The comparator status can be read from the I<sup>2</sup>C interface. For details on the I<sup>2</sup>C interface, please refer to the I<sup>2</sup>C/SMBUS Interface section of this data sheet.

## VMON Voltage Measurement with the On-chip Analog to Digital Converter (ADC)

The ispPAC-POWR1220 has an on-chip analog to digital converter that can be used for measuring the voltages at the VMON inputs. The ADC is also used in closed loop trimming of DC-DC converters. Close loop trimming is covered later in this document.

**Figure 9. ADC Monitoring VMON1 to VMON12**

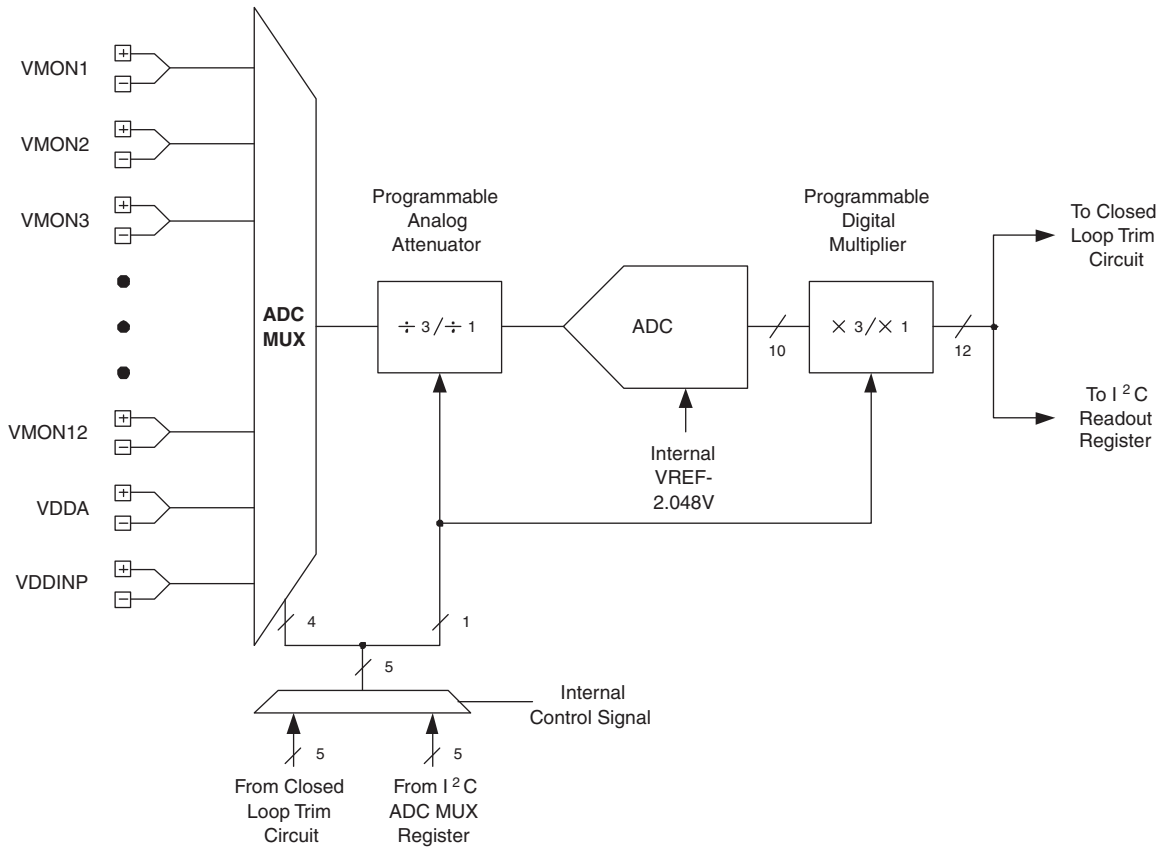

Figure 9 shows the ADC circuit arrangement within the ispPAC-POWR1220AT8 device. The ADC can measure all analog input voltages through the multiplexer, ADC MUX. The programmable attenuator between the ADC mux and the ADC can be configured as divided-by-3 or divided-by-1 (no attenuation). The divided-by-3 setting is used to measure voltages from 0V to 6V range and divided-by-1 setting is used to measure the voltages from 0V to 2V range.

A microcontroller can place a request for any VMON voltage measurement at any time through the I<sup>2</sup>C bus. Upon the receipt of an I<sup>2</sup>C command, the ADC will be connected to the I<sup>2</sup>C selected VMON through the ADC MUX. The ADC output is then latched into the I<sup>2</sup>C readout registers.

### Calculation

The algorithm to convert the ADC code to the corresponding voltage takes into consideration the attenuation bit value. In other words, if the attenuation bit is set, then the 10-bit ADC result is automatically multiplied by 3 to calculate the actual voltage at that V<sub>MON</sub> input. Thus, the I<sup>2</sup>C readout register is 12 bits instead of 10 bits. The following formula can always be used to calculate the actual voltage from the ADC code.

### Voltage at the VMONx Pins

$$\text{VMON} = \text{ADC code (12 bits}^1, \text{ converted to decimal)} * 2\text{mV}$$

<sup>1</sup>Note: ADC\_VALUE\_HIGH (8 bits), ADC\_VALUE\_LOW (4 bits) read from I<sup>2</sup>C/SMBUS interface

### PLD Block

Figure 10 shows the ispPAC-POWR1220AT8 PLD architecture, which is derived from the Lattice's ispMACH™ 4000 CPLD. The PLD architecture allows the flexibility in designing various state machines and control functions used for power supply management. The AND array has 83 inputs and generates 243 product terms. These 243 product terms are divided into three groups of 81 for each of the generic logic blocks, GLB1, GLB2, and GLB3. Each GLB is made up of 16 macrocells. In total, there are 48 macrocells in the ispPAC-POWR1220AT8 device. The output signals of the ispPAC-POWR1220AT8 device are derived from GLBs as shown in Figure 10. Additionally, the GLB3 generates the timer control and trimming block controls.

**Figure 10. ispPAC-POWR1220AT8 PLD Architecture**

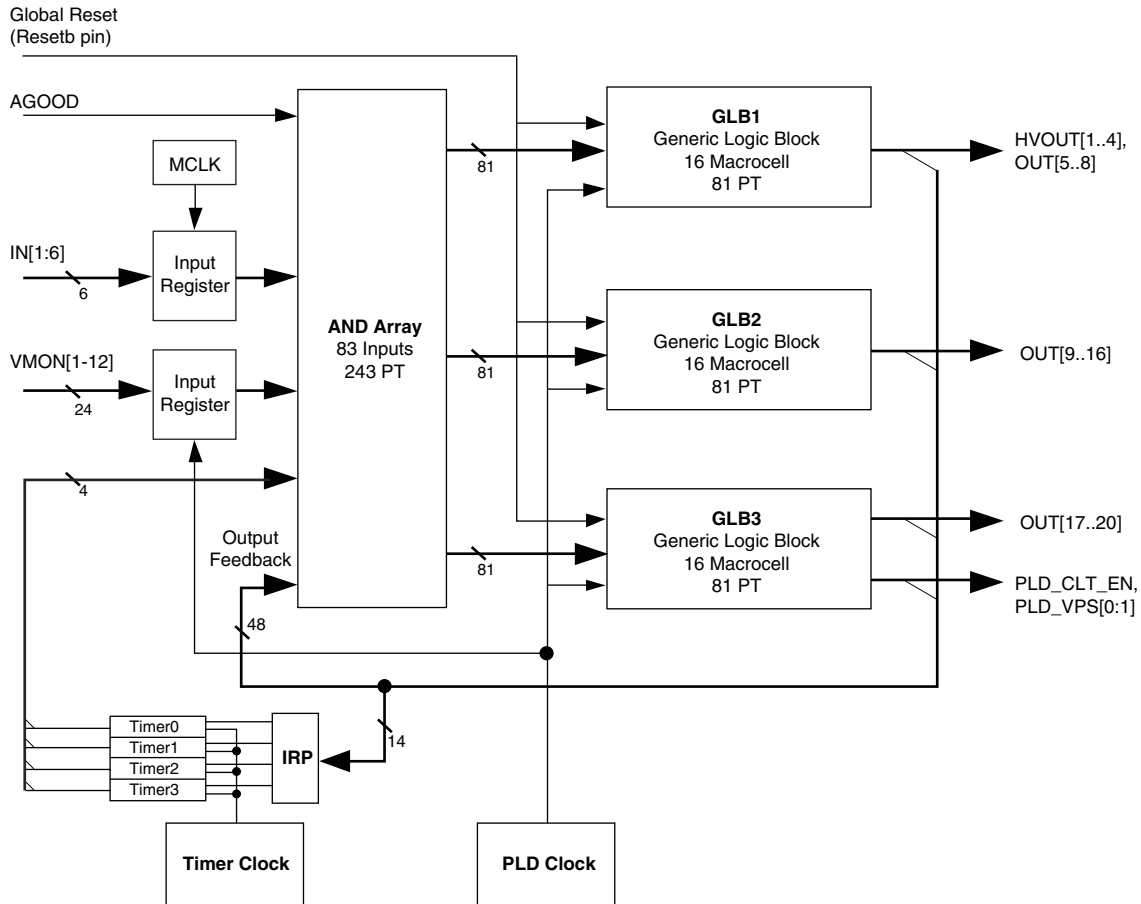

### Macrocell Architecture

The macrocell shown in Figure 11 is the heart of the PLD. The basic macrocell has five product terms that feed the OR gate and the flip-flop. The flip-flop in each macrocell is independently configured. It can be programmed to function as a D-Type or T-Type flip-flop. Combinatorial functions are realized by bypassing the flip-flop. The polarity control and XOR gates provide additional flexibility for logic synthesis. The flip-flop's clock is driven from the common PLD clock that is generated by dividing the 8 MHz master clock (MCLK) by 32. The macrocell also supports asynchronous reset and preset functions, derived from either product terms, the global reset input, or the power-on reset signal. The resources within the macrocells share routing and contain a product term allocation array. The product term allocation array greatly expands the PLD's ability to implement complex logical functions by allowing logic to be shared between adjacent blocks and distributing the product terms to allow for wider decode functions. All the digital inputs are registered by MCLK and the VMON comparator outputs are registered by the PLD Clock to synchronize them to the PLD logic.

Figure 11. ispPAC-POWR1220AT8 Macrocell Block Diagram

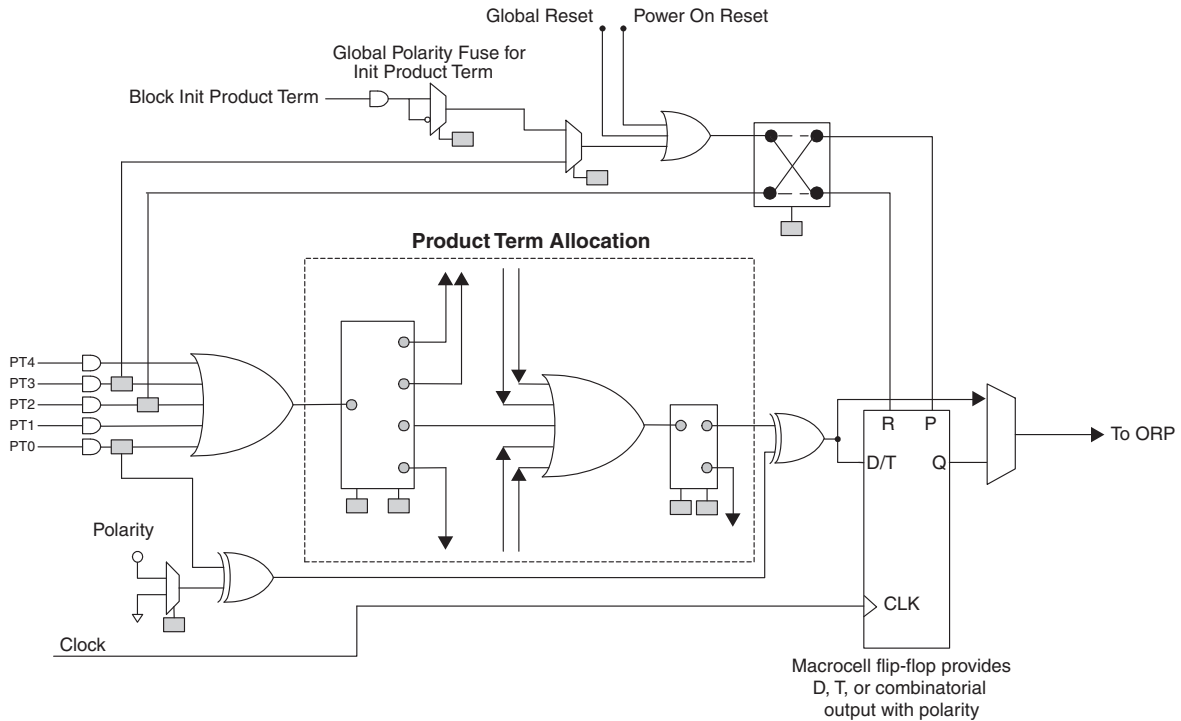

### Clock and Timer Functions

Figure 12 shows a block diagram of the ispPAC-POWR1220AT8's internal clock and timer systems. The master clock operates at a fixed frequency of 8MHz, from which a fixed 250kHz PLD clock is derived.

Figure 12. Clock and Timer System

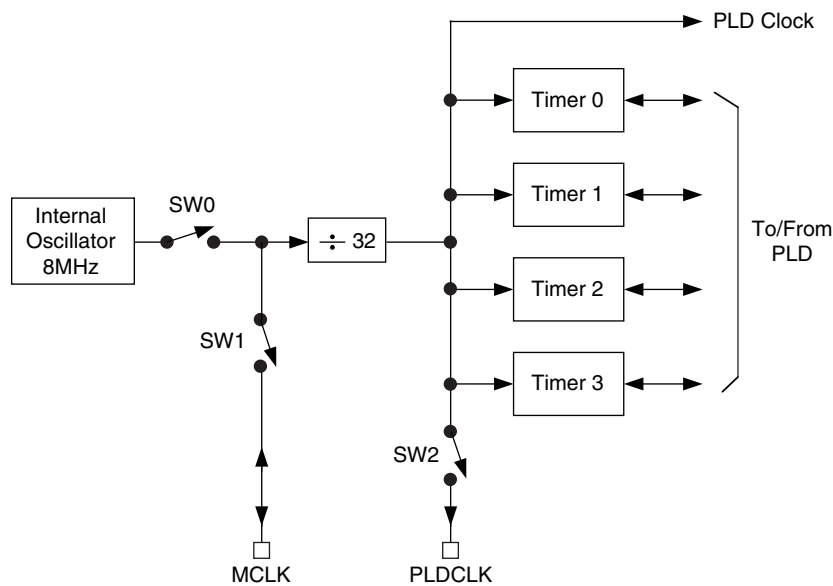

The internal oscillator runs at a fixed frequency of 8 MHz. This signal is used as a source for the PLD and timer clocks. It is also used for clocking the comparator outputs and clocking the digital filters in the voltage monitor circuits, ADC and trim circuits. The ispPAC-POWR1220AT8 can be programmed to operate in three modes: Master

mode, Standalone mode and Slave mode. Table 5 summarizes the operating modes of ispPAC-POWR1220AT8.

**Table 5. ispPAC-POWR1220AT8 Operating Modes**

Timer Operating Mode	SW0	SW1	Condition	Comments
Standalone	Closed	Open	When only one ispPAC-POWR1220AT8 is used.	MCLK pin tristated
Master	Closed	Closed	When more than one ispPAC-POWR1220AT8 is used in a board, one of them should be configured to operate in this mode.	MCLK pin outputs 8MHz clock
Slave	Open	Closed	When more than one ispPAC-POWR1220AT8s is used in a board. Other than the master, the rest of the ispPAC-POWR1220AT8s should be programmed as slaves.	MCLK pin is input

A divide-by-32 prescaler divides the internal 8MHz oscillator (or external clock, if selected) down to 250kHz for the PLD clock and for the programmable timers. This PLD clock may be made available on the PLDCLK pin by closing SW2. Each of the four timers provides independent timeout intervals ranging from 32µs to 1.96 seconds in 128 steps.

### Digital Outputs

The ispPAC-POWR1220AT8 provides 20 digital outputs, HVOUT[1:4] and OUT[5:20]. Outputs OUT[5:20] are permanently configured as open drain to provide a high degree of flexibility when interfacing to logic signals, LEDs, opto-couplers, and power supply control inputs. The HVOUT[1:4] pins can be configured as either high voltage FET drivers or open drain outputs. Each of these outputs may be controlled either from the PLD or from the I<sup>2</sup>C bus. The determination whether a given output is under PLD or I<sup>2</sup>C control may be made on a pin-by-pin basis (see Figure 13). For further details on controlling the outputs through I<sup>2</sup>C, please see the I<sup>2</sup>C/SMBUS Interface section of this data sheet.

**Figure 13. Digital Output Pin Configuration**

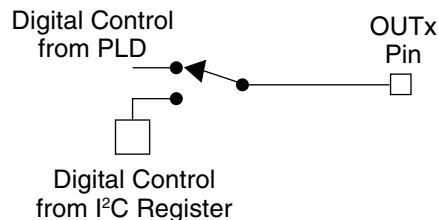

### High-Voltage Outputs

In addition to being usable as digital open-drain outputs, the ispPAC-POWR1220AT8's HVOUT1-HVOUT4 output pins can be programmed to operate as high-voltage FET drivers. Figure 14 shows the details of the HVOUT gate drivers. Each of these outputs may be controlled from the PLD or from the I<sup>2</sup>C bus (see Figure 14). For further details on controlling the outputs through I<sup>2</sup>C, please see the I<sup>2</sup>C/SMBUS Interface section of this data sheet.

**Figure 14. Basic Function Diagram for an Output in High Voltage MOSFET Gate Driver Mode**

Figure 14 shows the HVOUT circuitry when programmed as a FET driver. In this mode the output either sources current from a charge pump or sinks current. The maximum voltage that the output level at the pin will rise to is also programmable between 6V and 12V. The maximum voltage levels that are required depend on the gate-to-source threshold of the FET being driven and the power supply voltage being switched. The maximum voltage level needs to be sufficient to bias the gate-to-source threshold on and also accommodate the load voltage at the FET's source, since the source pin of the FET to provide a wide range of ramp rates is tied to the supply of the target board. When the HVOUT pin is sourcing current, charging a FET gate, the source current is programmable between 12.5 $\mu$ A and 100 $\mu$ A. When the driver is turned to the off state, the driver will sink current to ground, and this sink current is also programmable between 3000 $\mu$ A and 100 $\mu$ A to control the turn-off rate.

#### Programmable Output Voltage Levels for HVOUT1- HVOUT4

There are three selectable steps for the output voltage of the FET drivers when in FET driver mode. The voltage that the pin is capable of driving to can be programmed from 6V to 12V in 2V steps.

#### Controlling Power Supply Output Voltage by Margin/ Trim Block

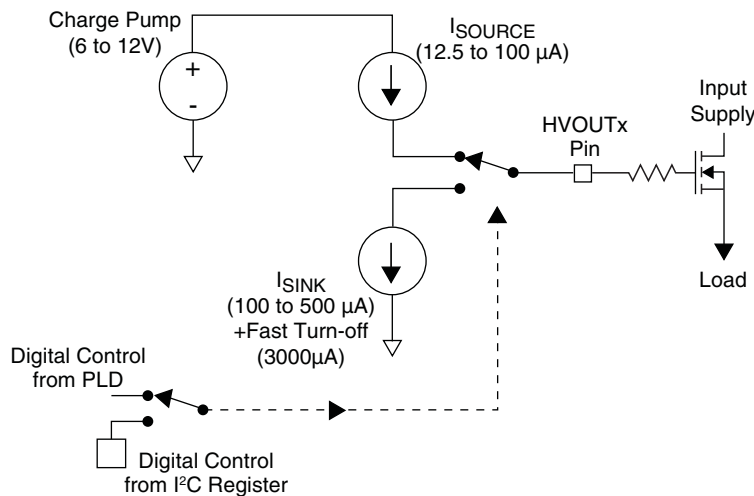
One of the key features of the ispPAC-POWR1220AT8 is its ability to make adjustments to the power supplies that it may also be monitoring and/or sequencing. This is accomplished through the Trim and Margin Block of the device. The Trim and Margin Block can adjust voltages of up to eight different power supplies through TrimCells as shown in Figure 15. The DC-DC blocks in the figure represent virtually any type of DC power supply that has a trim or voltage adjustment input. This can be an off-the-shelf unit or custom circuit designed around a switching regulator IC.

The interface between the ispPAC-POWR1220AT8 and the DC power supply is represented by a single resistor (R1 to R8) to simplify the diagram. Each of these resistors represents a resistor network.

Other control signals driving the Margin/Trim Block are:

- VPS [1:0] – Control signals from device pins common to all eight TrimCells, which are used to select the active voltage profile for all TrimCells together.
- PLD\_VPS[1:0] – Voltage profile selection signals generated by the PLD. These signals can be used instead of the VPS signals from the pins.
- ADC input – Used to determine the trimmed DC-DC converter voltage.
- PLD\_CLT\_EN – Only from PLD, used to enable closed loop trimming of all TrimCells together.

Next to each DC-DC converter, four voltages are shown. These voltages correspond to the operating voltage profile of the Margin/Trim Block.

When the VPS[1:0] = 00, representing Voltage Profile 0: (Voltage Profile 0 is recommended to be used for the normal circuit operation)

The output voltage of the DC-DC converter controlled by the Trim 1 pin of the ispPAC-POWR1220AT8 will be 1V and that TrimCell is operating in closed loop trim mode. At the same time, the DC-DC converters controlled by Trim 2, Trim 3 and Trim 8 pins output 1.2V, 1.5V and 3.3V respectively.

When the VPS[1:0] = 01, representing Voltage Profile 1 being active:

The DC-DC output voltage controlled by Trim 1, 2, 3, and 8 pins will be 1.05V, 1.26V, 1.57V, and 3.46V. These supply voltages correspond to 5% above their respective normal operating voltage (also called as margin high).

Similarly, when VPS[1:0] = 11, all DC-DC converters are margined low by 5%.

**Figure 15. ispPAC-POWR1220AT8 Trim and Margin Block**

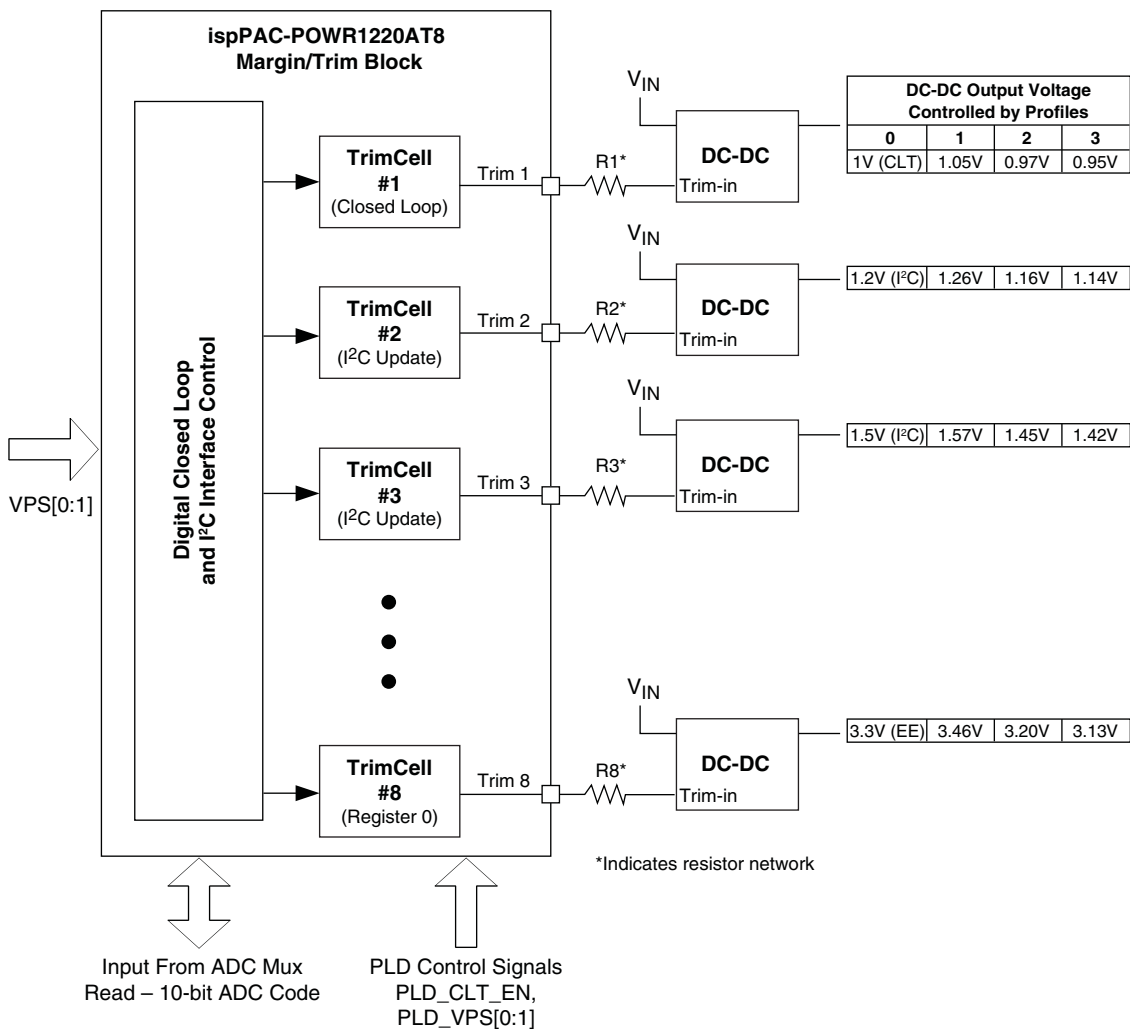

There are eight TrimCells in the ispPAC-POWR1220AT8 device, enabling simultaneous control of up to eight individual power supplies. Each TrimCell can generate up to four trimming voltages to control the output voltage of the DC-DC converter.

Figure 16. TrimCell Driving a Typical DC-DC Converter

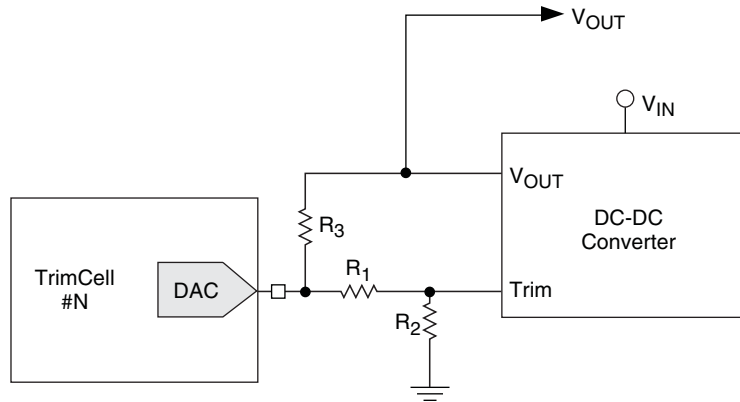
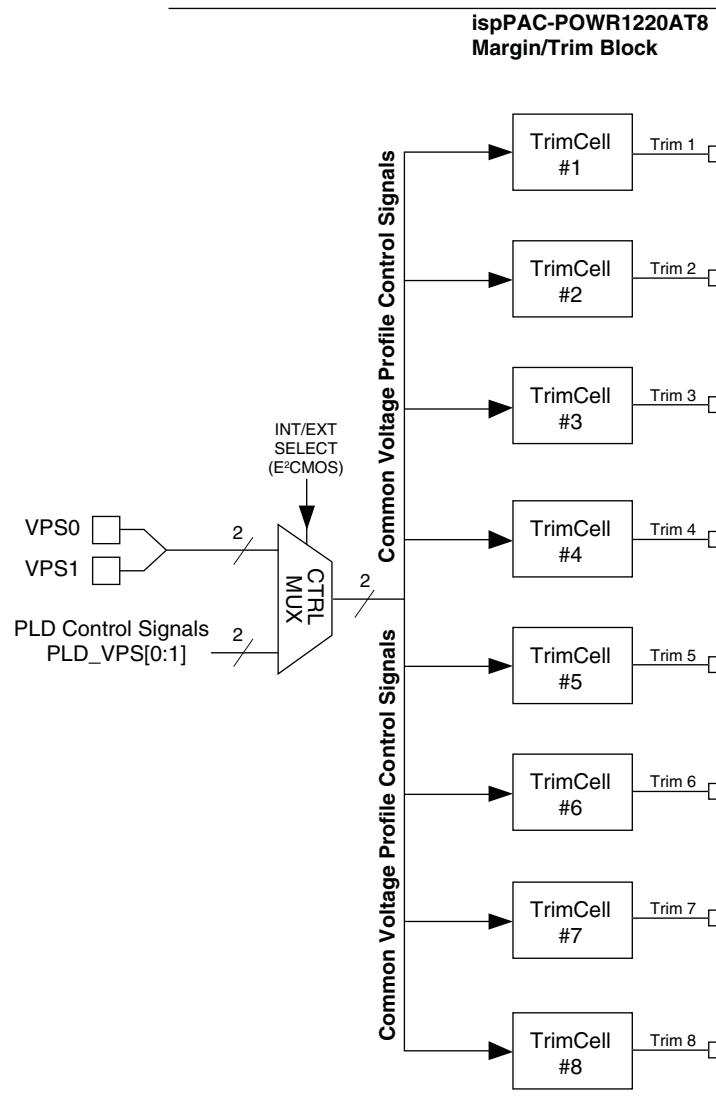

Figure 16 shows the resistor network between the TrimCell #N in the ispPAC-POWR1220AT8 and the DC-DC converter. The values of these resistors depend on the type of DC-DC converter used and its operating voltage range. The method to calculate the values of the resistors R1, R2, and R3 are described in a separate application note.

### Voltage Profile Control

The Margin / Trim Block of ispPAC-POWR1220AT8 consists of eight TrimCells. Because all eight TrimCells in the Margin / Trim Block are controlled by two common voltage profile control signals, they all operate at the same voltage profile. These common voltage profile control signals are derived from a Control Multiplexer. One set of voltage profile control inputs to the control multiplexer is from a pair of device pins: VPS0, VPS1. The second set of voltage profile control inputs is from the PLD: PLD\_VPS0, PLD\_VPS1. The selection between the two sets of voltage profile control signals is programmable and is stored in the E<sup>2</sup>CMOS memory.

Figure 17. Voltage Profile Control



**TrimCell Architecture**

The TrimCell block diagram is shown in Figure 18. The 8-bit DAC at the output provides the trimming voltage required to set the output voltage of a programmable supply. Each TrimCell can be operated in any one of the four voltage profiles. In each voltage profile the output trimming voltage can be set to a preset value. There are six 8-bit registers in each TrimCell that, depending on the operational mode, set the DAC value. Of these, four DAC values (DAC Register 0 to DAC Register 3) are stored in the E<sup>2</sup>CMOS memory while the remaining register contents are stored in volatile registers. Two multiplexers (Mode Mux and Profile Mux) control the routing of the code to the DAC. The Profile Mux can be controlled by common TrimCell voltage profile control signals.

**Figure 18. ispPAC-POWR1220AT8 Output TrimCell**

Figure 15 shows four power supply voltages next to each DC-DC converter. When the Profile MUX is set to Voltage Profile 3, the DC supply controlled by Trim 1 will be at 0.95V, the DC supply controlled by Trim 2 will be at 1.14V, 1.43V for Trim 3 and 3.14V for Trim 8. When Voltage Profile 0 is selected, Trim 1 will set the supply to 1V, Trim 2 and Trim 3 will be set by the values that have been loaded using I<sup>2</sup>C at 1.2 and 1.5V, and Trim 8 will be set to 3.3V.

The following table summarizes the voltage profile selection and the corresponding DAC output trimming voltage. The voltage profile selection is common to all eight TrimCells.

**Table 6. TrimCell Voltage Profile and Operating Modes**

PLD_VPS[1:0] or VPS[1:0]	Selected Voltage Profile	Selected Mode	Trimming Voltage is Controlled by
11	Voltage Profile 3	—	DAC Register 3 (E <sup>2</sup> CMOS)
10	Voltage Profile 2	—	DAC Register 2 (E <sup>2</sup> CMOS)
01	Voltage Profile 1	—	DAC Register 1 (E <sup>2</sup> CMOS)
00	Voltage Profile 0	DAC Register 0 Select	DAC Register 0 (E <sup>2</sup> CMOS)
		DAC Register I <sup>2</sup> C Select	DAC Register (I <sup>2</sup> C)
		Digital Closed Loop Trim	Closed Loop Trim Register

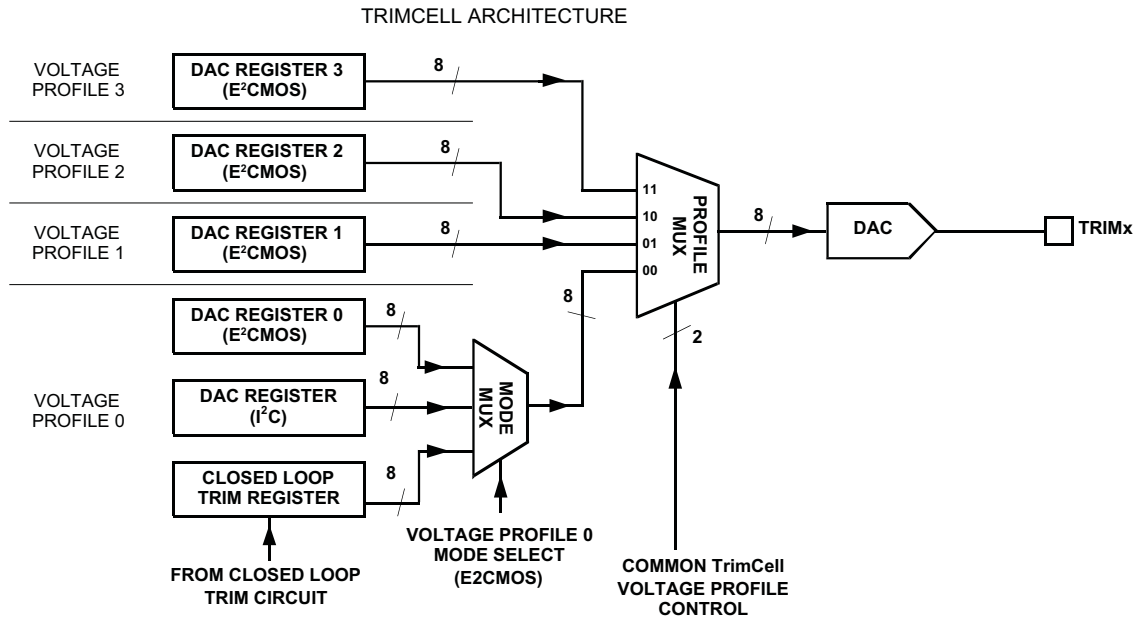
**TrimCell Operation in Voltage Profiles 1, 2 and 3:** The output trimming voltage is determined by the code stored in the DAC Registers 1, 2, and 3 corresponding to the selected Voltage Profile.

**TrimCell Operation in Voltage Profile 0:** The Voltage Profile 0 has three operating modes. They are DAC Register 0 Select mode, DAC Register I<sup>2</sup>C Select mode and Closed Loop Trim mode. The mode selection is stored in the E<sup>2</sup>CMOS configuration memory. Each of the eight TrimCells can be independently set to different operating modes during Voltage Profile 0 mode of operation.

**DAC Register 0 Select Mode:** The contents of DAC register 0 are stored in the on-chip E<sup>2</sup>CMOS memory. When Voltage Profile 0 is selected, the DAC will be loaded with the value stored in DAC Register 0.

**DAC Register I<sup>2</sup>C Select Mode:** This mode is used if the power management arrangement requires an external microcontroller to control the DC-DC converter output voltage. The microcontroller updates the contents of the

DAC Register I<sup>2</sup>C on the fly to set the trimming voltage to a desired value. The DAC Register I<sup>2</sup>C is a volatile register and is reset to 80H (DAC at Bipolar zero) upon power-on. The external microcontroller writes the correct DAC code in this DAC Register I<sup>2</sup>C before enabling the programmable power supply.

### Digital Closed Loop Trim Mode

Closed loop trim mode operation can be used when tight control over the DC-DC converter output voltage at a desired value is required. The closed loop trim mechanism operates by comparing the measured output voltage of the DC-DC converter with the internally stored voltage setpoint. The difference between the setpoint and the actual DC-DC converter voltage generates an error voltage. This error voltage adjusts the DC-DC converter output voltage toward the setpoint. This operation iterates until the setpoint and the DC-DC converter voltage are equal.

Figure 19 shows the closed loop trim operation of a TrimCell. At regular intervals (as determined by the Update Rate Control register) the ispPAC-POWR1220AT8 device initiates the closed loop power supply voltage correction cycle through the following blocks:

- Non-volatile **Setpoint** register stores the desired output voltage
- On-chip **ADC** is used to measure the voltage of the DC-DC converter
- **Three-state comparator** is used to compare the measured voltage from the ADC with the **Setpoint** register contents. The output of the three state comparator can be one of the following:
  - +1 if the setpoint voltage is greater than the DC-DC converter voltage
  - -1 if the setpoint voltage is less than the DC-DC converter voltage
  - 0 if the setpoint voltage is equal to the DC-DC converter voltage
- **Channel polarity control** determines the polarity of the error signal
- **Closed loop trim register** is used to compute and store the DAC code corresponding to the error voltage. The contents of the Closed Loop Trim will be incremented or decremented depending on the channel polarity and the three-state comparator output. If the three-state comparator output is 0, the closed loop trim register contents are left unchanged.
- The **DAC** in the **TrimCell** is used to generate the analog error voltage that adjusts the attached DC-DC converter output voltage.

**Figure 19. Digital Closed Loop Trim Operation**

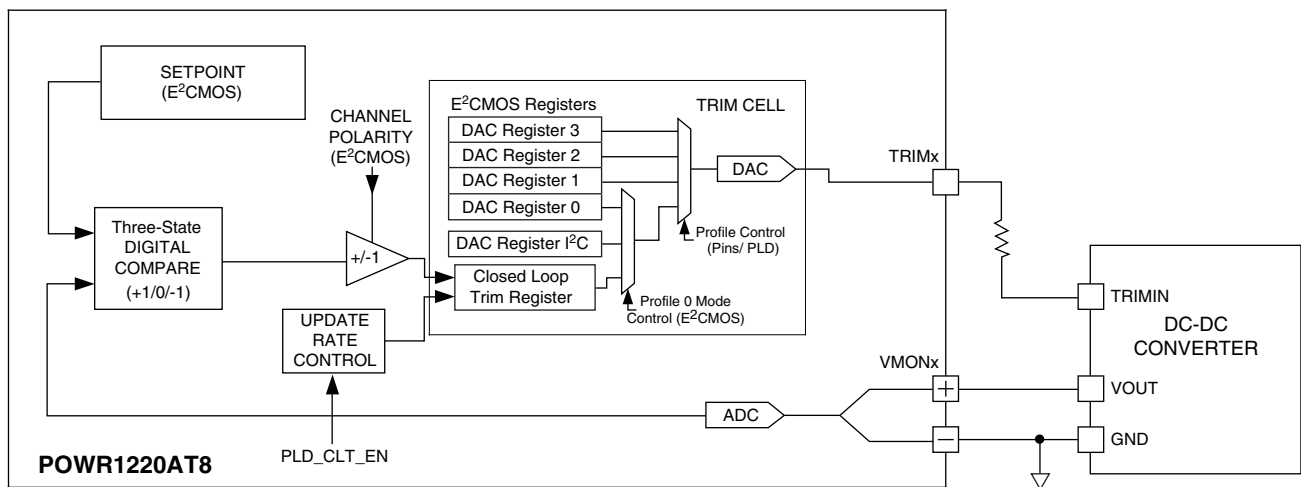

The closed loop trim cycle interval is programmable and is set by the update rate control register. The following table lists the programmable update interval that can be selected by the update rate register.

**Table 7. Output DAC Update Rate in Digital Closed Loop Mode**

Update Rate Control Value	Update Interval
00	580 $\mu$ s
01	1.15 ms
10	9.22 ms
11	18.5 ms

There is a one-to-one relationship between the selected TrimCell and the corresponding VMON input for the closed loop operation. For example, if TrimCell 3 is used to control the power supply in the closed loop trim mode, VMON3 must be used to monitor its output power supply voltage.

The closed loop operation can only be started by activating the internally generated PLD signal, called PLD\_CLT\_EN, in PAC-Designer software. The selection of Voltage Profile 0, however, can be either through the pins VPS0, VPS1 or through the PLD signals PLDVPS0 and PLDVPS1.

### Closed Loop Start-up Behavior

The contents of the closed loop register, upon power-up, will contain a value 80h (Bipolar-zero) value. The DAC output voltage will be equal to the programmed Offset voltage. Usually under this condition, the power supply output will be close to its nominal voltage. If the power supply trimming should start after reaching its desired output voltage, the corresponding DAC code can be loaded into the closed loop trim register through I<sup>2</sup>C (same address as the DAC register I<sup>2</sup>C mode) before activating the PLD\_CLT\_EN signal.

### Details of the Digital to Analog Converter (DAC)

Each trim cell has an 8-bit bipolar DAC to set the trimming voltage (Figure 20). The full-scale output voltage of the DAC is +/- 320 mV. A code of 80H results in the DAC output set at its bi-polar zero value.

The voltage output from the DAC is added to a programmable offset value and the resultant voltage is then applied to the trim output pin. The offset voltage is typically selected to be approximately equal to the DC-DC converter open circuit trim node voltage. This results in maximizing the DC-DC converter output voltage range.

The programmed offset value can be set to 0.6V, 0.8V, 1.0V or 1.25V. This value selection is stored in E<sup>2</sup>CMOS memory and cannot be changed dynamically.

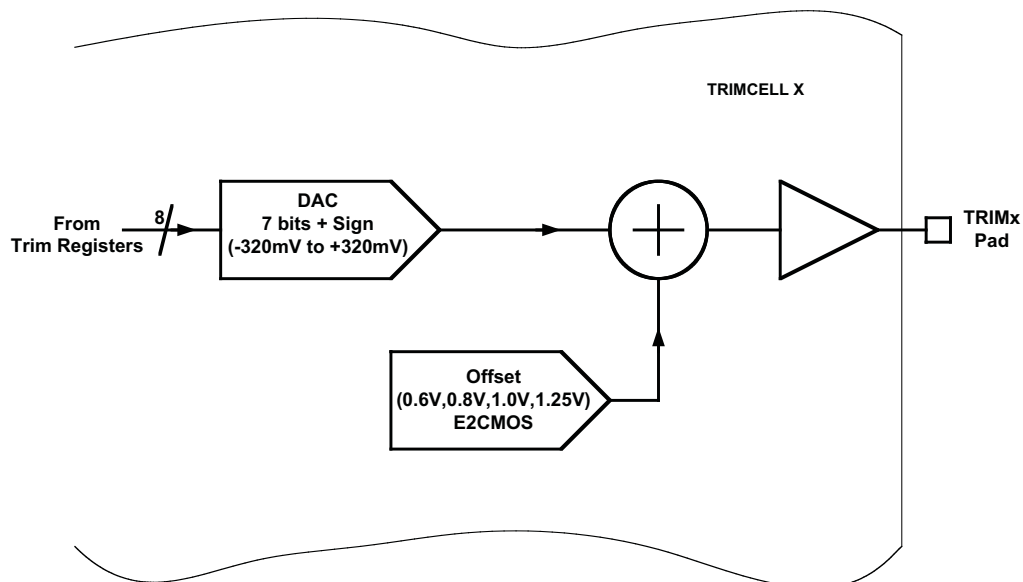
**Figure 20. Offset Voltage is Added to DAC Output Voltage to Derive Trim Pad Voltage**

## RESETb Signal, RESET Command via JTAG or I<sup>2</sup>C

Activating the RESETb signal (Logic 0 applied to the RESETb pin) or issuing a reset instruction via JTAG or I<sup>2</sup>C will force the outputs to the following states independent of how these outputs have been configured in the PINS window:

- OUT5-20 will go high-impedance.
- HVOUT pins programmed for open drain operation will go high-impedance.
- HVOUT pins programmed for FET driver mode operation will pull down.

At the conclusion of the RESET event, these outputs will go to the states defined by the PINS window, and if a sequence has been programmed into the device, it will be re-started at the first step. The analog calibration will be re-done and consequently, the VMONs, ADCs, and DACs will not be operational until 2.5 milliseconds (max.) after the conclusion of the RESET event.

**CAUTION:** Activating the RESETb signal or issuing a RESET command through I<sup>2</sup>C or JTAG during the ispPAC-POWR1220AT8 device operation, results in the device aborting all operations and returning to the power-on reset state. The status of the power supplies which are being enabled by the ispPAC-POWR1220AT8 will be determined by the state of the outputs shown above.

## I<sup>2</sup>C/SMBUS Interface

I<sup>2</sup>C and SMBus are low-speed serial interface protocols designed to enable communications among a number of devices on a circuit board. The ispPAC-POWR1220AT8 supports a 7-bit addressing of the I<sup>2</sup>C communications protocol, as well as SMBTimeout and SMBAlert features of the SMBus, enabling it to easily integrated into many types of modern power management systems. Figure 21 shows a typical I<sup>2</sup>C configuration, in which one or more ispPAC-POWR1220AT8s are slaved to a supervisory microcontroller. SDA is used to carry data signals, while SCL provides a synchronous clock signal. The SMBAlert line is only present in SMBus systems. The 7-bit I<sup>2</sup>C address of the POWR1220AT8 is fully programmable through the JTAG port.

Figure 21. ispPAC-POWR1220AT8 in I<sup>2</sup>C/SMBUS System

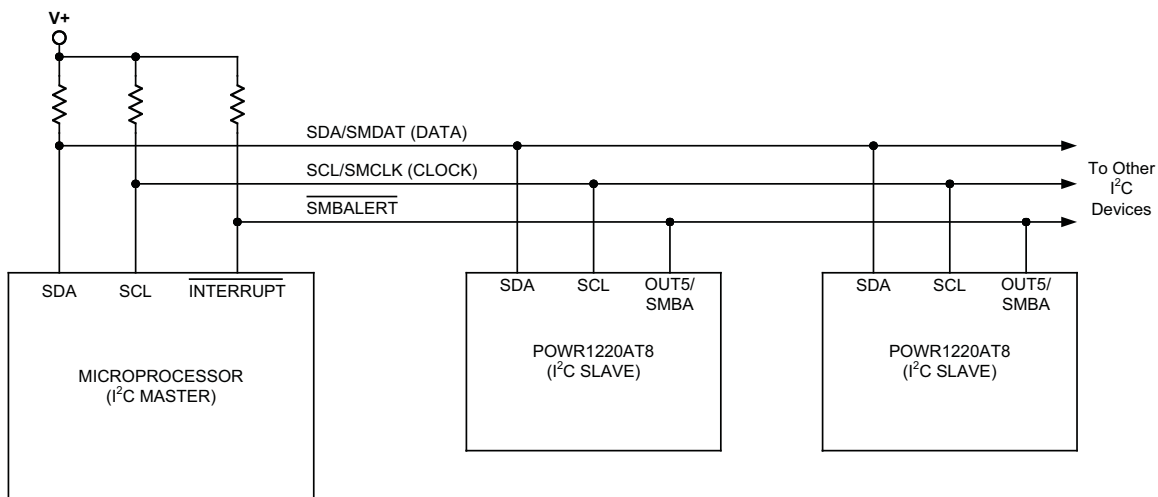

In both the I<sup>2</sup>C and SMBus protocols, the bus is controlled by a single MASTER device at any given time. This master device generates the SCL clock signal and coordinates all data transfers to and from a number of slave devices. The ispPAC-POWR1220AT8 is configured as a slave device, and cannot independently coordinate data transfers. Each slave device on a given I<sup>2</sup>C bus is assigned a unique address. The ispPAC-POWR1220AT8 implements the 7-bit addressing portion of the standard. Any 7-bit address can be assigned to the ispPAC-POWR1220AT8 device by programming through JTAG. When selecting a device address, one should note that several addresses are reserved by the I<sup>2</sup>C and/or SMBus standards, and should not be assigned to ispPAC-POWR1220AT8 devices to assure bus compatibility. Table 8 lists these reserved addresses.

**Table 8. I<sup>2</sup>C/SMBus Reserved Slave Device Addresses**

Address	R/W bit	I <sup>2</sup> C function Description	SMBus Function
0000 000	0	General Call Address	General Call Address
0000 000	1	Start Byte	Start Byte
0000 001	x	CBUS Address	CBUS Address
0000 010	x	Reserved	Reserved
0000 011	x	Reserved	Reserved
0000 1xx	x	HS-mode master code	HS-mode master code
0001 000	x	NA	SMBus Host
0001 100	x	NA	SMBus Alert Response Address
0101 000	x	NA	Reserved for ACCESS.bus
0110 111	x	NA	Reserved for ACCESS.bus
1100 001	x	NA	SMBus Device Default Address
1111 0xx	x	10-bit addressing	10-bit addressing
1111 1xx	x	Reserved	Reserved

The ispPAC-POWR1220AT8's I<sup>2</sup>C/SMBus interface allows data to be both written to and read from the device. A data write transaction (Figure 22) consists of the following operations:

1. Start the bus transaction
2. Transmit the device address (7 bits) along with a low write bit
3. Transmit the address of the register to be written to (8 bits)
4. Transmit the data to be written (8 bits)
5. Stop the bus transaction

To start the transaction, the master device holds the SCL line high while pulling SDA low. Address and data bits are then transferred on each successive SCL pulse, in three consecutive byte frames of 9 SCL pulses. Address and data are transferred on the first 8 SCL clocks in each frame, while an acknowledge signal is asserted by the slave device on the 9th clock in each frame. Both data and addresses are transferred in a most-significant-bit-first format. The first frame contains the 7-bit device address, with bit 8 held low to indicate a write operation. The second frame contains the register address to which data will be written, and the final frame contains the actual data to be written. Note that the SDA signal is only allowed to change when the SCL is low, as raising SDA when SCL is high signals the end of the transaction.

**Figure 22. I<sup>2</sup>C Write Operation**

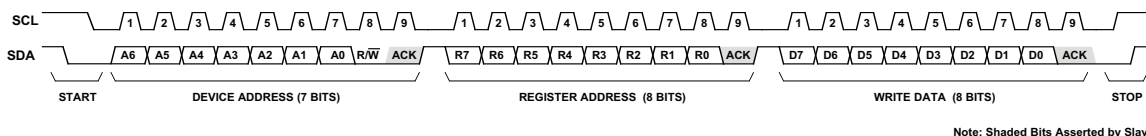

Reading a data byte from the ispPAC-POWR1220AT8 requires two separate bus transactions (Figure 23). The first transaction writes the register address from which a data byte is to be read. Note that since no data is being written to the device, the transaction is concluded after the second byte frame. The second transaction performs the actual read. The first frame contains the 7-bit device address with the R/W bit held High. In the second frame the ispPAC-POWR1220AT8 asserts data out on the bus in response to the SCL signal. Note that the acknowledge signal in the second frame is asserted by the master device and not the ispPAC-POWR1220AT8.

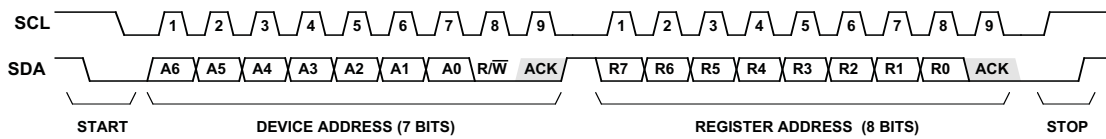
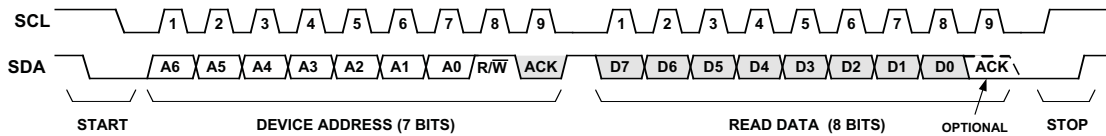
**Figure 23. I<sup>2</sup>C Read Operation**
**STEP 1: WRITE REGISTER ADDRESS FOR READ OPERATION**

**STEP 2: READ DATA FROM THAT REGISTER**

Note: Shaded Bits Asserted by Slave

The ispPAC-POWR1220AT8 provides 26 registers that can be accessed through its I<sup>2</sup>C interface. These registers provide the user with the ability to monitor and control the device's inputs and outputs, and transfer data to and from the device. Table provides a summary of these registers.

**Table 9. I<sup>2</sup>C Control Registers**

Register Address	Register Name	Read/Write	Description	Value After POR <sup>1,2</sup>
0x00	vmon_status0	R	VMON input status Vmon[4:1]	---- ----
0x01	vmon_status1	R	VMON input status Vmon[8:5]	---- ----
0x02	vmon_status2	R	VMON input status Vmon[12:9]	---- ----
0x03	output_status0	R	Output status OUT[8:5], HVOUT[4:1]	---- ----
0x04	output_status1	R	Output status OUT[16:9]	---- ----
0x05	output_status2	R	Output status OUT[20:17]	X X X X ----
0x06	input_status	R	Input status IN[6:1]	X X -- ----
0x07	adc_value_low	R	ADC D[3:0] and status	---- X X X 1
0x08	adc_value_high	R	ADC D[11:4]	---- ----
0x09	adc_mux	R/W	ADC Attenuator and MUX[3:0]	X X X 1 1 1 1 1
0x0A	UES_byte0	R	UES[7:0]	---- ----
0x0B	UES_byte1	R	UES[15:8]	---- ----
0x0C	UES_byte2	R	UES[23:16]	---- ----
0x0D	UES_byte3	R	UES[31:24]	---- ----
0x0E	gp_output1	R/W	GPOUT[8:1]	0 0 0 1 0 0 0 0
0x0F	gp_output2	R/W	GPOUT[16:9]	0 0 0 0 0 0 0 0
0x10	gp_output3	R/W	GPOUT[20:17]	X X X X 0 0 0 0
0x11	input_value	R/W	PLD Input Register [6:2]	X X 0 0 0 0 0 X
0x12	reset	W	Resets device on write	N/A
0x13	trim1_trim	R/W	Trim DAC 1 [7:0]	1 0 0 0 0 0 0 0
0x14	trim2_trim	R/W	Trim DAC 2 [7:0]	1 0 0 0 0 0 0 0
0x15	trim3_trim	R/W	Trim DAC 3 [7:0]	1 0 0 0 0 0 0 0
0x16	trim4_trim	R/W	Trim DAC 4 [7:0]	1 0 0 0 0 0 0 0
0x17	trim5_trim	R/W	Trim DAC 5 [7:0]	1 0 0 0 0 0 0 0
0x18	trim6_trim	R/W	Trim DAC 6 [7:0]	1 0 0 0 0 0 0 0

**Table 9. I<sup>2</sup>C Control Registers (Cont.)**

Register Address	Register Name	Read/Write	Description	Value After POR <sup>1,2</sup>
0x19	trim7_trim	R/W	Trim DAC 7 [7:0]	1 0 0 0 0 0 0 0
0x1A	trim8_trim	R/W	Trim DAC 8 [7:0]	1 0 0 0 0 0 0 0

1. "X" = Non-functional bit (bits read out as 1's).

2. "-" = State depends on device configuration or input status.

Several registers are provided for monitoring the status of the analog inputs. The three registers VMON\_STATUS[0:2] provide the ability to read the status of the VMON output comparators. The ability to read both the 'a' and 'b' comparators from each VMON input is provided through the VMON input registers. Note that if a VMON input is configured to window comparison mode, then the corresponding VMONxA register bit will reflect the status of the window comparison.

**Figure 24. VMON Status Registers**
**0x00 - VMON\_STATUS0 (Read Only)**

VMON4B	VMON4A	VMON3B	VMON3A	VMON2B	VMON2A	VMON1B	VMON1A
b7	b6	b5	b4	b3	b2	b1	b0

**0x01 - VMON\_STATUS1 (Read Only)**

VMON8B	VMON8A	VMON7B	VMON7A	VMON6B	VMON6A	VMON5B	VMON5A
b7	b6	b5	b4	b3	b2	b1	b0

**0x02 - VMON\_STATUS2 (Read Only)**

VMON12B	VMON12A	VMON11B	VMON11A	VMON10B	VMON10A	VMON9B	VMON9A
b7	b6	b5	b4	b3	b2	b1	b0

It is also possible to directly read the value of the voltage present on any of the VMON inputs by using the ispPAC-POWR1220AT8's ADC. Three registers provide the I<sup>2</sup>C interface to the ADC (Figure 24).

**Figure 25. ADC Interface Registers**
**0x07 - ADC\_VALUE\_LOW (Read Only)**

D3	D2	D1	D0	1	1	1	DONE
b7	b6	b5	b4	b3	b2	b1	b0

**0x08 - ADC\_VALUE\_HIGH (Read Only)**

D11	D10	D9	D8	D7	D6	D5	D4
b7	b6	b5	b4	b3	b2	b1	b0

**0x09 - ADC\_MUX (Read/Write)**

X	X	X	ATTEN	SEL3	SEL2	SEL1	SEL0
b7	b6	b5	b4	b3	b2	b1	b0

To perform an A/D conversion, one must set the input attenuator and channel selector. Two input ranges may be set using the attenuator, 0 - 2.048V and 0 - 6.144V. Table 10 shows the input attenuator settings.

**Table 10. ADC Input Attenuator Control**

ATTEN (ADC_MUX.4)	Resolution	Full-Scale Range
0	2mV	2.048 V
1	6mV	6.144 V

The input selector may be set to monitor any one of the twelve VMON inputs, the VCCA input, or the VCCINP input. Table 11 shows the codes associated with each input selection.

**Table 11. V<sub>MON</sub> Address Selection Table**

Select Word				Input Channel
SEL3 (ADC_MUX.3)	SEL2 (ADC_MUX.2)	SEL1 (ADC_MUX.1)	SEL0 (ADC_MUX.0)	
0	0	0	0	VMON1
0	0	0	1	VMON2
0	0	1	0	VMON3
0	0	1	1	VMON4
0	1	0	0	VMON5
0	1	0	1	VMON6
0	1	1	0	VMON7
0	1	1	1	VMON8
1	0	0	0	VMON9
1	0	0	1	VMON10
1	0	1	0	VMON11
1	0	1	1	VMON12
1	1	0	0	VCCA
1	1	0	1	VCCINP

Writing a value to the ADC\_MUX register to set the input attenuator and selector will automatically initiate a conversion. When the conversion is in process, the DONE bit (ADC\_VALUE\_LOW.0) will be reset to 0. When the conversion is complete, this bit will be set to 1. When the conversion is complete, the result may be read out of the ADC by performing two I<sup>2</sup>C read operations; one for ADC\_VALUE\_LOW, and one for ADC\_VALUE\_HIGH. It is recommended that the I<sup>2</sup>C master load a second conversion command only after the completion of the current conversion command (Waiting for the DONE bit to be set to 1). An alternative would be to wait for a minimum specified time (see T<sub>CONVERT</sub> value in the specifications) and disregard checking the DONE bit.

Note that if the I<sup>2</sup>C clock rate falls below 50kHz (see F<sub>I<sup>2</sup>C</sub> note in specifications), the only way to insure a valid ADC conversion is to wait the minimum specified time (T<sub>CONVERT</sub>), as the operation of the DONE bit at clock rates lower than that cannot be guaranteed. In other words, if the I<sup>2</sup>C clock rate is less than 50kHz, the DONE bit may or may not assert even though a valid conversion result is available.

To insure every ADC conversion result is valid, preferred operation is to clock I<sup>2</sup>C at more than 50kHz and verify DONE bit status or wait for the full T<sub>CONVERT</sub> time period between subsequent ADC convert commands. If an I<sup>2</sup>C request is placed before the current conversion is complete, the DONE bit will be set to 1 only after the second request is complete.

The status of the digital input lines may also be monitored and controlled through I<sup>2</sup>C commands. Figure 26 shows the I<sup>2</sup>C interface to the IN[1:6] digital input lines. The input status may be monitored by reading the INPUT\_STATUS register, while input values to the PLD array may be set by writing to the INPUT\_VALUE register. To be able to set an input value for the PLD array, the input multiplexer associated with that bit needs to be set to the I<sup>2</sup>C register setting in E<sup>2</sup>CMOS memory otherwise the PLD will receive its input from the INx pin.

Figure 26. I<sup>2</sup>C Digital Input Interface

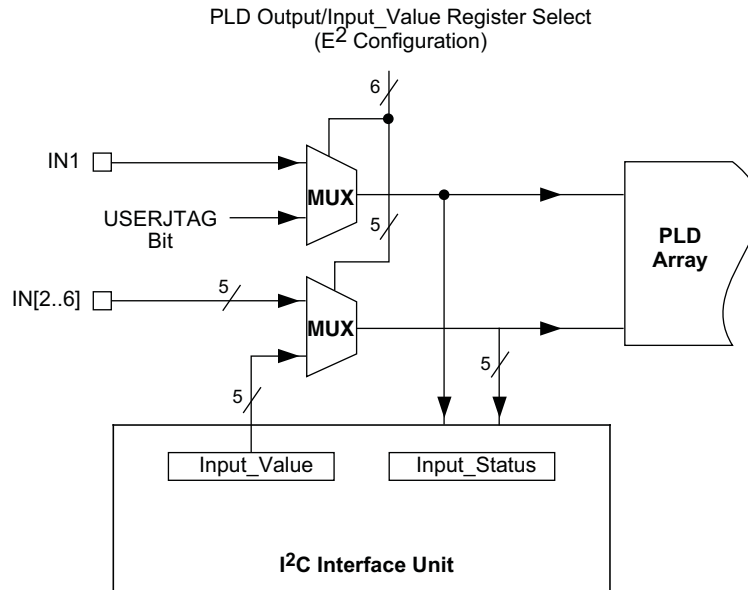

**0x06 - INPUT\_STATUS (Read Only)**

X	X	IN6	IN5	IN4	IN3	IN2	IN1
b7	b6	b5	b4	b3	b2	b1	b0

**0x11 - INPUT\_VALUE (Read/Write)**

X	X	I6	I5	I4	I3	I2	X
b7	b6	b5	b4	b3	b2	b1	b0

The digital outputs may also be monitored and controlled through the I<sup>2</sup>C interface, as shown in Figure 27. The status of any given digital output may be read by reading the contents of the associated OUTPUT\_STATUS[2:0] register. Note that in the case of the outputs, the status reflected by these registers reflects the logic signal used to drive the pin, and does not sample the actual level present on the output pin. For example, if an output is set high but is not pulled up, the output status bit corresponding with that pin will read '1', but a high output signal will not appear on the pin.

Digital outputs may also be optionally controlled directly by the I<sup>2</sup>C bus instead of by the PLD array. The outputs may be driven either from the PLD ORP or from the contents of the GP\_OUTPUT[2:0] registers with the choice user-settable in E<sup>2</sup>CMOS memory. Each output may be independently set to output from the PLD or from the GP\_OUTPUT registers.

Figure 27. I<sup>2</sup>C Output Monitor and Control Logic

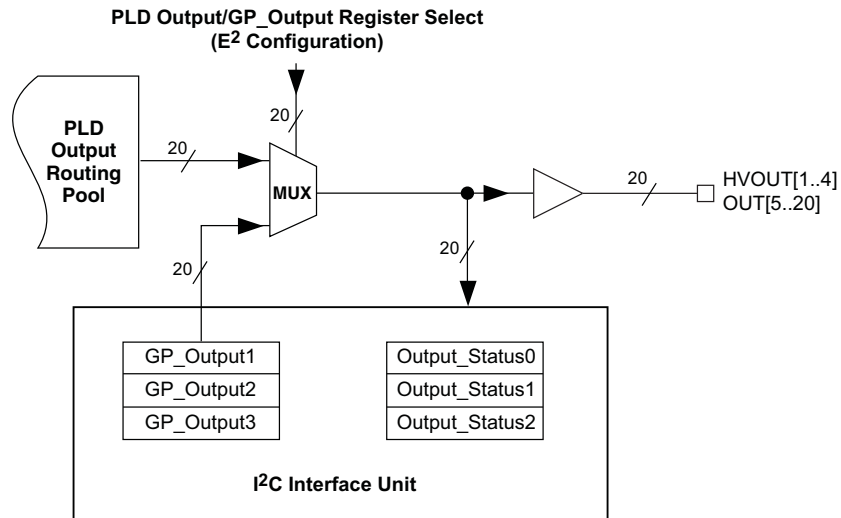

**0x03 - OUTPUT\_STATUS0 (Read Only)**

OUT8	OUT7	OUT6	OUT5	HVOUT4	HVOUT3	HVOUT2	HVOUT1
b7	b6	b5	b4	b3	b2	b1	b0

**0x04 - OUTPUT\_STATUS1 (Read Only)**

OUT16	OUT15	OUT14	OUT13	OUT12	OUT11	OUT10	OUT9
b7	b6	b5	b4	b3	b2	b1	b0

**0x05 - OUTPUT\_STATUS2 (Read Only)**

X	X	X	X	OUT20	OUT19	OUT18	OUT17
b7	b6	b5	b4	b3	b2	b1	b0

**0x0E - GP\_OUTPUT1 (Read/Write)**

GP8	GP7	GP6	GP5_ENb	GP4	GP3	GP2	GP1
b7	b6	b5	b4	b3	b2	b1	b0

**0x0F - GP\_OUTPUT2 (Read/Write)**

GP16	GP15	GP14	GP13	GP12	GP11	GP10	GP9
b7	b6	b5	b4	b3	b2	b1	b0

**0x10 - GP\_OUTPUT3 (Read/Write)**

X	X	X	X	GP20	GP19	GP18	GP17
b7	b6	b5	b4	b3	b2	b1	b0

The UES word may also be read through the I<sup>2</sup>C interface, with the register mapping shown in Figure 28.

**Figure 28. I<sup>2</sup>C Register Mapping for UES Bits**

**0x0A - UES\_BYTE0 (Read Only)**

UES7	UES6	UES5	UES4	UES3	UES2	UES1	UES0
b7	b6	b5	b4	b3	b2	b1	b0

**0x0B - UES\_BYTE1 (Read Only)**

UES15	UES14	UES13	UES12	UES11	UES10	UES9	UES8
b7	b6	b5	b4	b3	b2	b1	b0

**0x0C - UES\_BYTE2 (Read Only)**

UES23	UES22	UES21	UES20	UES19	UES18	UES17	UES16
b7	b6	b5	b4	b3	b2	b1	b0

**0x0D - UES\_BYTE3 (Read Only)**

UES31	UES30	UES29	UES28	UES27	UES26	UES25	UES24
b7	b6	b5	b4	b3	b2	b1	b0

The I<sup>2</sup>C interface also provides the ability to initiate reset operations. The ispPAC-POWR1220AT8 may be reset by issuing a write of any value to the I<sup>2</sup>C RESET register (Figure 29). Note: The execution of the I<sup>2</sup>C reset command is equivalent to toggling the Resetb pin of the chip. Refer to the Resetb Signal, RESET Command via JTAG or I<sup>2</sup>C section of this data sheet for further information.

**Figure 29. I<sup>2</sup>C Reset Register**

**0x12 - RESET (Write Only)**

X	X	X	X	X	X	X	X
b7	b6	b5	b4	b3	b2	b1	b0

The ispPAC-POWR1220AT8 also provides the user with the ability to program the trim values over the I<sup>2</sup>C interface, by writing the appropriate binary word to the associated trim register (Figure 30).

**Figure 30. I<sup>2</sup>C Trim Registers**

**0x13 - TRIM1\_TRIM (Read/Write)**

D7	D6	D5	D4	D3	D2	D1	D0
b7	b6	b5	b4	b3	b2	b1	b0

**0x14 - TRIM2\_TRIM (Read/Write)**

D7	D6	D5	D4	D3	D2	D1	D0
b7	b6	b5	b4	b3	b2	b1	b0

**0x15 - TRIM3\_TRIM (Read/Write)**

D7	D6	D5	D4	D3	D2	D1	D0
b7	b6	b5	b4	b3	b2	b1	b0

**0x16 - TRIM4\_TRIM (Read/Write)**

D7	D6	D5	D4	D3	D2	D1	D0
b7	b6	b5	b4	b3	b2	b1	b0

**0x17 - TRIM5\_TRIM (Read/Write)**

D7	D6	D5	D4	D3	D2	D1	D0
b7	b6	b5	b4	b3	b2	b1	b0

**0x18 - TRIM6\_TRIM (Read/Write)**

D7	D6	D5	D4	D3	D2	D1	D0
b7	b6	b5	b4	b3	b2	b1	b0

**0x19 - TRIM7\_TRIM (Read/Write)**

D7	D6	D5	D4	D3	D2	D1	D0
b7	b6	b5	b4	b3	b2	b1	b0

**0x1A - TRIM8\_TRIM (Read/Write)**

D7	D6	D5	D4	D3	D2	D1	D0
b7	b6	b5	b4	b3	b2	b1	b0

### SMBus SMBAlert Function

The ispPAC-POWR1220AT8 provides an SMBus SMBAlert function so that it can request service from the bus master when it is used as part of an SMBus system. This feature is supported as an alternate function of OUT5. When the SMBAlert feature is enabled, OUT5 is controlled by a combination of the PLD ORP and the GP5\_ENb bit (Figure 31). Note: To enable the SMBAlert feature, the SMB\_Mode (EECMOS bit) should be set in software.

**Figure 31. ispPAC-POWR1220AT8 SMBAlert Logic**

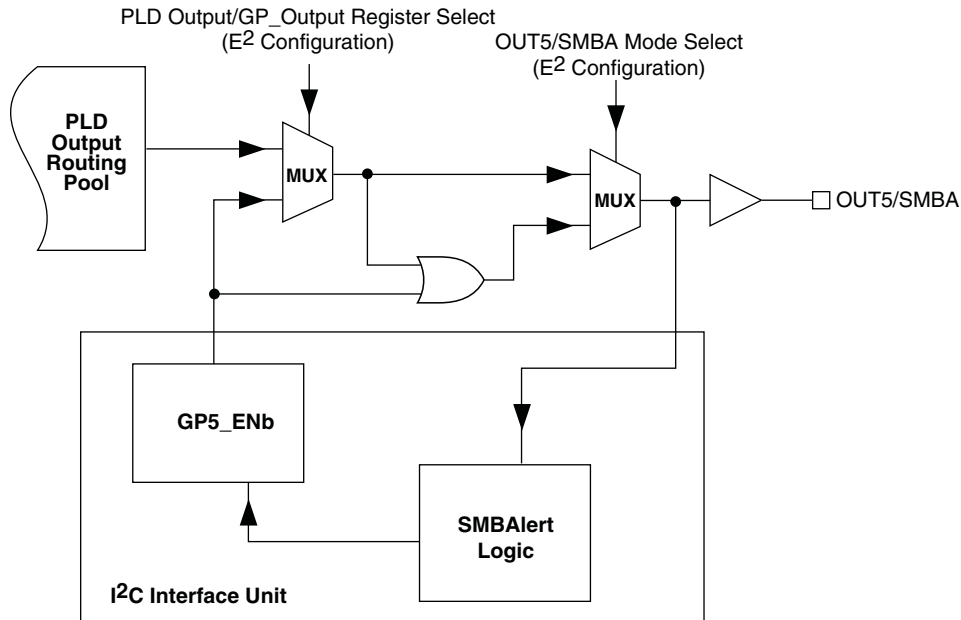

The typical flow for an SMBAlert transaction is as follows (Figure 31):

1. GP5\_ENb bit is forced (Via I<sup>2</sup>C write) to Low
2. ispPAC-POWR1220AT8 PLD Logic pulls OUT5/SMBA Low
3. Master responds to interrupt from SMBA line
4. Master broadcasts a read operation using the SMBus Alert Response Address (ARA)
5. ispPAC-POWR1220AT8 responds to read request by transmitting its device address
6. If transmitted device address matches ispPAC-POWR1220AT8 address, it sets GP5\_ENb bit high. This releases OUT5/SMBA.

**Figure 32. SMBAlert Bus Transaction**

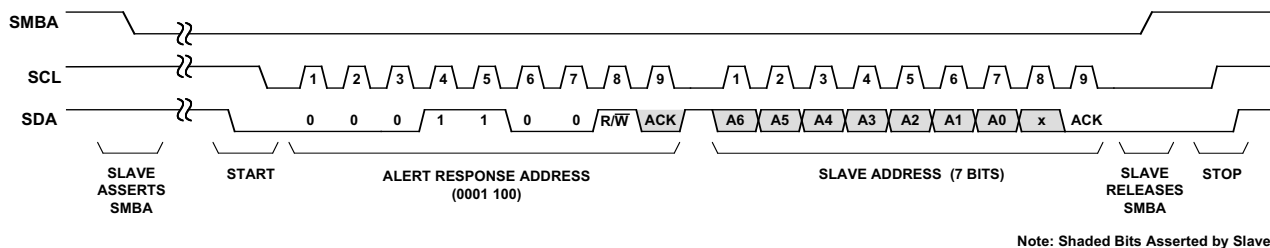

Note: Shaded Bits Asserted by Slave

After OUT5/SMBA has been released, the bus master (typically a microcontroller) may opt to perform some service functions in which it may send data to or read data from the ispPAC-POWR1220AT8. As part of the service functions, the bus master will typically need to clear whatever condition initiated the SMBAlert request, and will also need to reset GP5\_ENb to re-enable the SMBAlert function. For further information on the SMBus, the user should consult the SMBus Standard.

Designs using the SMBAlert feature are required to set the device's I<sup>2</sup>C/SMBus address to the lowest of all the addresses on that I<sup>2</sup>C/SMBus.

## Software-Based Design Environment

Designers can configure the ispPAC-POWR1220AT8 using PAC-Designer, an easy to use, Microsoft Windows compatible program. Circuit designs are entered graphically and then verified, all within the PAC-Designer environment. Full device programming is supported using PC parallel port I/O operations and a download cable connected to the serial programming interface pins of the ispPAC-POWR1220AT8. A library of configurations is included with basic solutions and examples of advanced circuit techniques are available on the Lattice web site for downloading. In addition, comprehensive on-line and printed documentation is provided that covers all aspects of PAC-Designer operation. The PAC-Designer schematic window, shown in Figure 33, provides access to all configurable ispPAC-POWR1220AT8 elements via its graphical user interface. All analog input and output pins are represented. Static or non-configurable pins such as power, ground, and the serial digital interface are omitted for clarity. Any element in the schematic window can be accessed via mouse operations as well as menu commands. When completed, configurations can be saved, simulated, and downloaded to devices.

Figure 33. PAC-Designer ispPAC-POWR1220AT8 Design Entry Screen

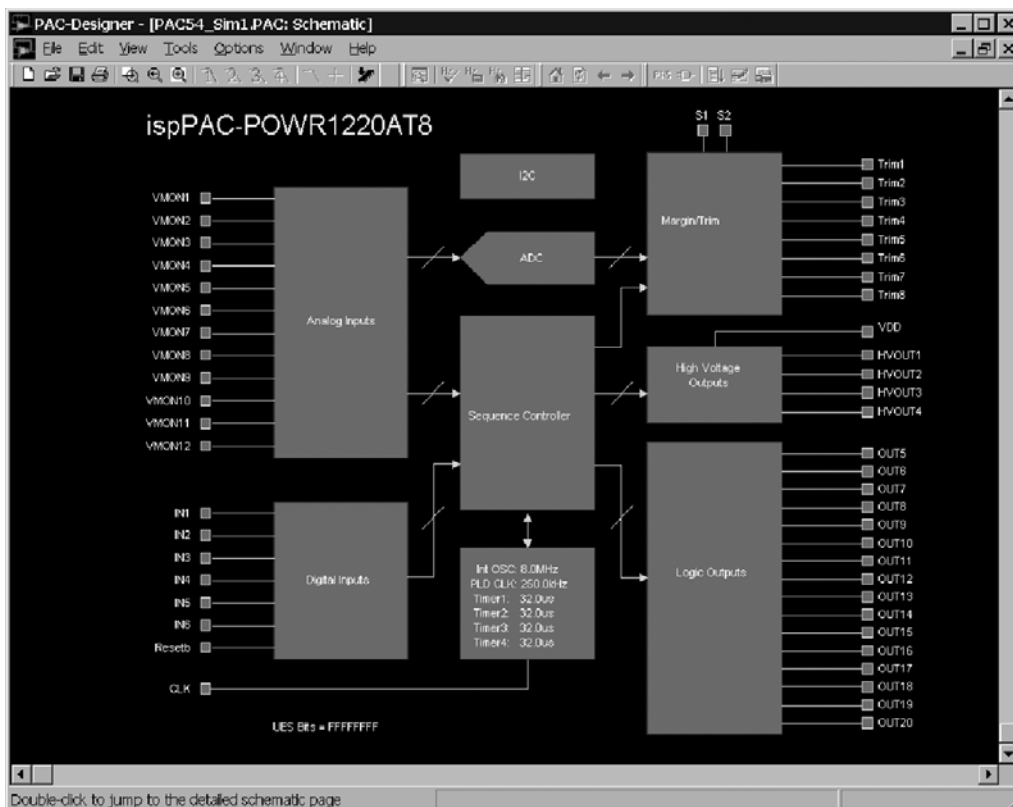

## In-System Programming

The ispPAC-POWR1220AT8 is an in-system programmable device. This is accomplished by integrating all E<sup>2</sup> configuration memory and control logic on-chip. Programming is performed through a 4-wire, IEEE 1149.1 compliant serial JTAG interface at normal logic levels (see Figure 34). Once a device is programmed, all configuration information is stored on-chip, in non-volatile E<sup>2</sup>CMOS memory cells. The specifics of the IEEE 1149.1 serial interface and all ispPAC-POWR1220AT8 instructions are described in the JTAG interface section of this data sheet.

Figure 34. ispPAC-POWR1220AT8 JTAG Interconnection Configuration Diagram

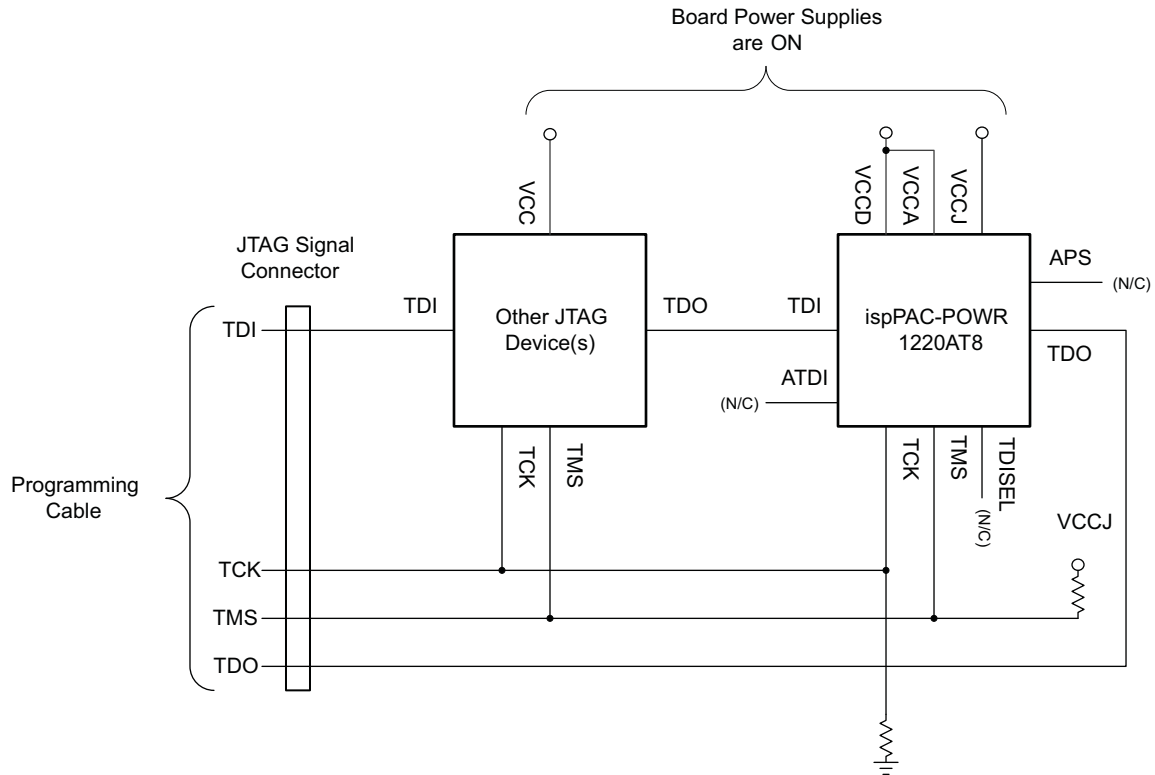

## Programming ispPAC-POWR1220AT8: Alternate Method

Some applications require that the ispPAC-POWR1220AT8 be programmed before turning the power on to the entire circuit board. To meet such application needs, the ispPAC-POWR1220AT8 provides an alternate programming method which enables the programming of the ispPAC-POWR1220AT8 device through the JTAG chain with a separate power supply applied just to the programming section of the ispPAC-POWR1220AT8 device with the main power supply of the board turned off.

Three special purpose pins, APS, ATDI and TDISEL, enable programming of the un-programmed ispPAC-POWR1220AT8 under such circumstances. The APS pin provides power to the programming circuitry of the ispPAC-POWR1220AT8 device (when VCCD and VCCA are unpowered). The VCCJ pin must be powered to enable the JTAG port. The ATDI pin provides an alternate connection to the JTAG header while bypassing all the un-powered devices in the JTAG chain. TDISEL pin enables switching between the ATDI and the standard JTAG signal TDI. When the internally pulled-up TDISEL = 1, standard TDI pin is enabled and when the TDISEL = 0, ATDI is enabled.

In order to use this feature the JTAG signals of the ispPAC-POWR1220AT8 are connected to the header as shown in Figure 35. Note: The ispPAC-POWR1220AT8 should be the last device in the JTAG chain.

After programming, the APS pin **MUST** be left floating when the VCCD and VCCA pins are powered.

Figure 35. ispPAC-POWR1220AT8 Alternate Configuration Diagram

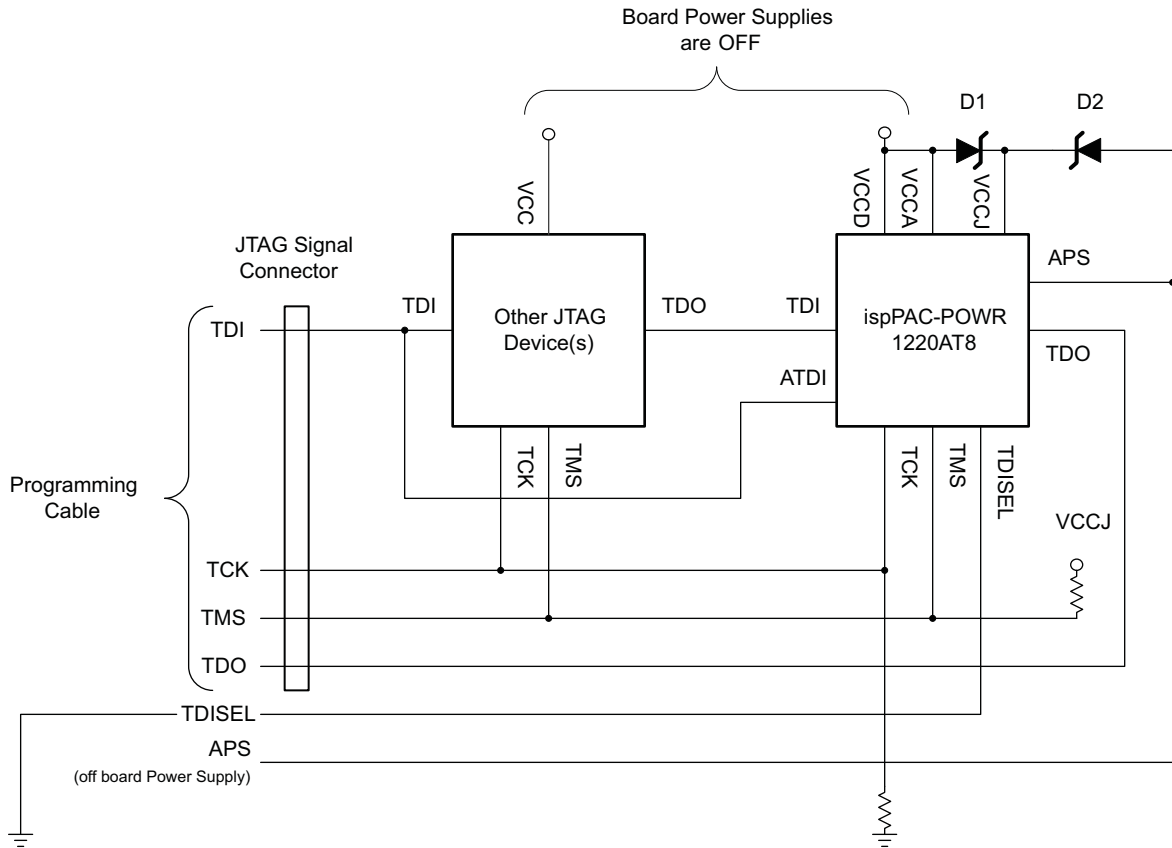

### Alternate TDI Selection Via JTAG Command

When the TDISEL pin held high and four consecutive IDCODE instructions are issued, ispPAC-POWR1220AT8 responds by making its active JTAG data input the ATDI pin. When ATDI is selected, data on its TDI pin is ignored until the JTAG state machine returns to the Test-Logic-Reset state.

This method of selecting ATDI takes advantage of the fact that a JTAG device with an IDCODE register will automatically load its unique IDCODE instruction into the Instruction Register after a Test-Logic-Reset. This JTAG capability permits blind interrogation of devices so that their location in a serial chain can be identified without having to know anything about them in advance. A blind interrogation can be made using only the TMS and TCLK control pins, which means TDI and TDO are not required for performing the operation. Figure 36 illustrates the logic for selecting whether the TDI or ATDI pin is the active data input to ispPAC-POWR1220AT8.

Figure 36. ispPAC-POWR1220AT8 TDI/ATDI Pin Selection Diagram

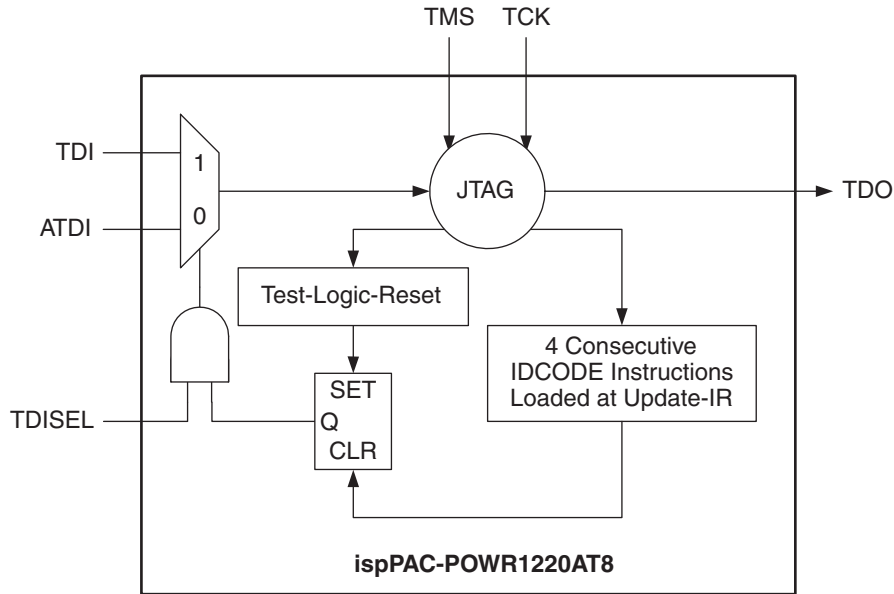

Table 12 shows in truth table form the same conditions required to select either TDI or ATDI as in the logic diagram found in Figure 36.

Table 12. ispPAC-POWR1220AT8 ATDI/TDI Selection Table

TDISEL Pin	JTAG State Machine Test-Logic-Reset	4 Consecutive IDCODE Commands Loaded at Update-IR	Active JTAG Data Input Pin
H	No	Yes	ATDI (TDI Disabled)
H	Yes	No	TDI (ATDI Disabled)
L	X	X	ATDI (TDI Disabled)

Please refer to the Lattice application note AN6068, *Programming the ispPAC-POWR1220AT8 in a JTAG Chain Using ATDI*. The application note includes specific SVF code examples and information on the use of Lattice design tools to verify device operation in alternate TDI mode.

### APS Power Supply Pin

Because the APS pin directly powers the on-chip programming circuitry, the ispPAC-POWR1220AT8 device can be programmed by applying power to the APS pin (without powering the entire chip though the VCCD and VCCA pins). In addition, to enable the on-chip JTAG interface circuitry, power should be applied to the VCCJ pin.

When the ispPAC-POWR1220AT8 is powered by the APS pin, no power should be applied to the VCCD and VCCA pins. Additionally, other than JTAG I/O pins, all digital output pins are in Hi-Z state, HVOUT pins configured as MOSFET driver are driven low, and all other inputs are ignored.

To switch the power supply back to VCCD and VCCA pins, one should turn the APS supply and VCCJ off before turning the regular supplies on. When VCCD and VCCA are turned back on for normal operation, APS **MUST** be left floating.

## User Electronic Signature

A user electronic signature (UES) feature is included in the E<sup>2</sup>CMOS memory of the ispPAC-POWR1220AT8. This consists of 32 bits that can be configured by the user to store unique data such as ID codes, revision numbers or inventory control data. The specifics of this feature are discussed in the IEEE 1149.1 serial interface section of this data sheet.

## Electronic Security

An electronic security “fuse” (ESF) bit is provided in every ispPAC-POWR1220AT8 device to prevent unauthorized readout of the E<sup>2</sup>CMOS configuration bit patterns. Once programmed, this cell prevents further access to the functional user bits in the device. This cell can only be erased by reprogramming the device, so the original configuration cannot be examined once programmed. Usage of this feature is optional. The specifics of this feature are discussed in the IEEE 1149.1 serial interface section of this data sheet.

## Production Programming Support

Once a final configuration is determined, an ASCII format JEDEC file can be created using the PAC-Designer software. Devices can then be ordered through the usual supply channels with the user’s specific configuration already preloaded into the devices. By virtue of its standard interface, compatibility is maintained with existing production programming equipment, giving customers a wide degree of freedom and flexibility in production planning.

## Evaluation Fixture

Included in the basic ispPAC-POWR1220AT8 Design Kit is an engineering prototype board that can be connected to the parallel port of a PC using a Lattice download cable. It demonstrates proper layout techniques for the ispPAC-POWR1220AT8 and can be used in real time to check circuit operation as part of the design process. Input and output connections are provided to aid in the evaluation of the ispPAC-POWR1220AT8 for a given application. (Figure 37).

**Figure 37. Download from a PC**

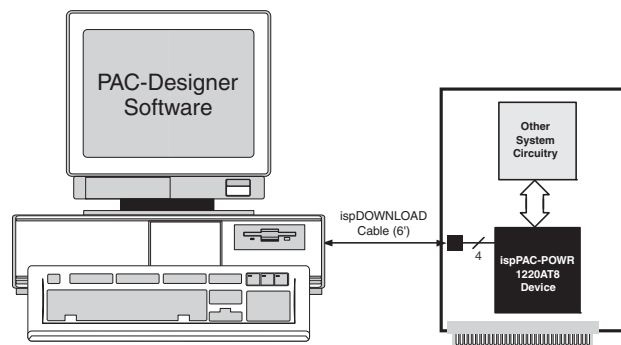

## IEEE Standard 1149.1 Interface (JTAG)

Serial Port Programming Interface Communication with the ispPAC-POWR1220AT8 is facilitated via an IEEE 1149.1 test access port (TAP). It is used by the ispPAC-POWR1220AT8 as a serial programming interface. A brief description of the ispPAC-POWR1220AT8 JTAG interface follows. For complete details of the reference specification, refer to the publication, Standard Test Access Port and Boundary-Scan Architecture, IEEE Std 1149.1-1990 (which now includes IEEE Std 1149.1a-1993).

## Overview

An IEEE 1149.1 test access port (TAP) provides the control interface for serially accessing the digital I/O of the ispPAC-POWR1220AT8. The TAP controller is a state machine driven with mode and clock inputs. Given in the correct sequence, instructions are shifted into an instruction register, which then determines subsequent data input, data output, and related operations. Device programming is performed by addressing the configuration register, shifting

data in, and then executing a program configuration instruction, after which the data is transferred to internal E<sup>2</sup>CMOS cells. It is these non-volatile cells that store the configuration or the ispPAC-POWR1220AT8. A set of instructions are defined that access all data registers and perform other internal control operations. For compatibility between compliant devices, two data registers are mandated by the IEEE 1149.1 specification. Others are functionally specified, but inclusion is strictly optional. Finally, there are provisions for optional data registers defined by the manufacturer. The two required registers are the bypass and boundary-scan registers. Figure 38 shows how the instruction and various data registers are organized in an ispPAC-POWR1220AT8.

**Figure 38. ispPAC-POWR1220AT8 TAP Registers**

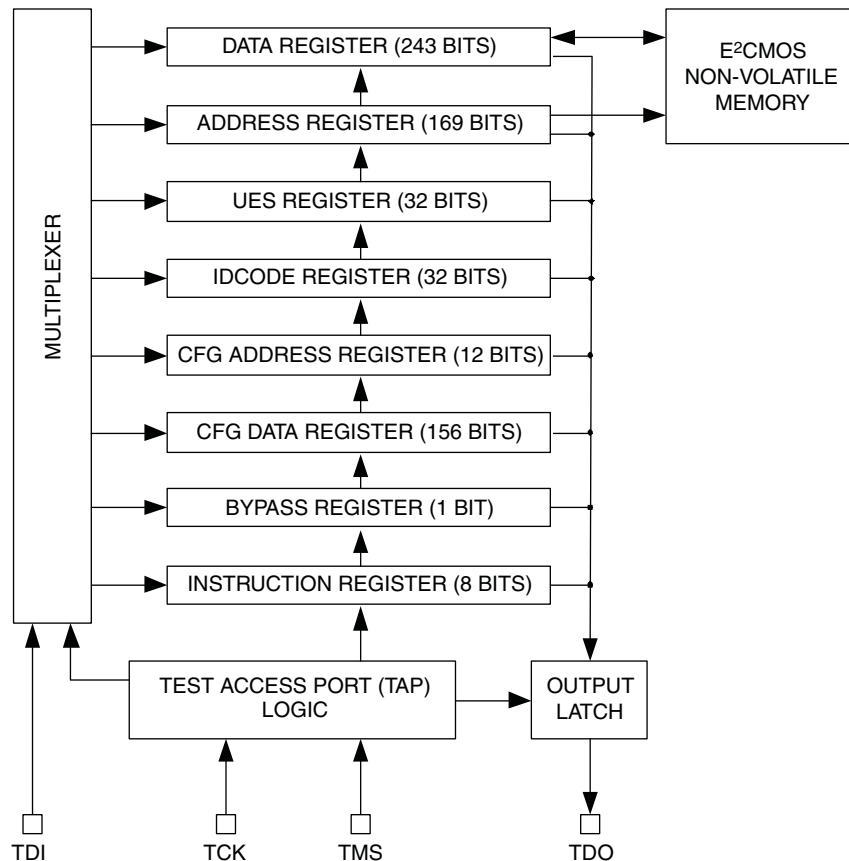

### TAP Controller Specifics

The TAP is controlled by the Test Clock (TCK) and Test Mode Select (TMS) inputs. These inputs determine whether an Instruction Register or Data Register operation is performed. Driven by the TCK input, the TAP consists of a small 16-state controller design. In a given state, the controller responds according to the level on the TMS input as shown in Figure 39. Test Data In (TDI) and TMS are latched on the rising edge of TCK, with Test Data Out (TDO) becoming valid on the falling edge of TCK. There are six steady states within the controller: Test-Logic-Reset, Run-Test/Idle, Shift-Data-Register, Pause-Data-Register, Shift-Instruction-Register and Pause-Instruction-Register. But there is only one steady state for the condition when TMS is set high: the Test-Logic-Reset state. This allows a reset of the test logic within five TCKs or less by keeping the TMS input high. Test-Logic-Reset is the power-on default state.

Figure 39. TAP States

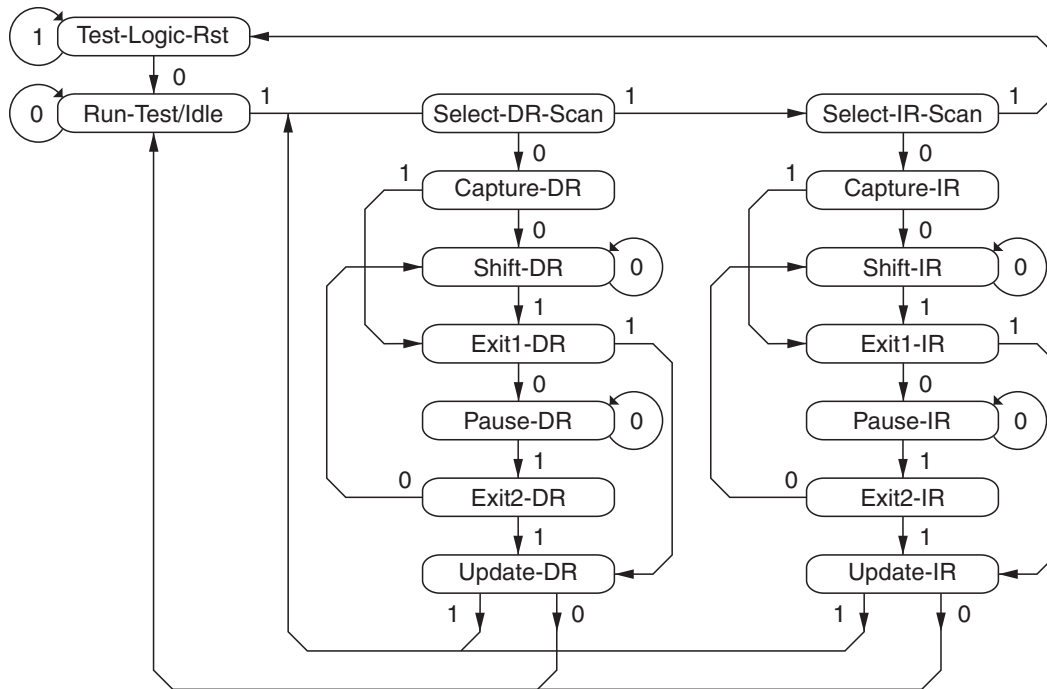

Note: The value shown adjacent to each state transition in this figure represents the signal present at TMS at the time of a rising edge at TCK.

When the correct logic sequence is applied to the TMS and TCK inputs, the TAP will exit the Test-Logic-Reset state and move to the desired state. The next state after Test-Logic-Reset is Run-Test/Idle. Until a data or instruction shift is performed, no action will occur in Run-Test/Idle (steady state = idle). After Run-Test/Idle, either a data or instruction shift is performed. The states of the Data and Instruction Register blocks are identical to each other differing only in their entry points. When either block is entered, the first action is a capture operation. For the Data Registers, the Capture-DR state is very simple: it captures (parallel loads) data onto the selected serial data path (previously chosen with the appropriate instruction). For the Instruction Register, the Capture-IR state will always load the IDCODE instruction. It will always enable the ID Register for readout if no other instruction is loaded prior to a Shift-DR operation. This, in conjunction with mandated bit codes, allows a “blind” interrogation of any device in a compliant IEEE 1149.1 serial chain. From the Capture state, the TAP transitions to either the Shift or Exit1 state. Normally the Shift state follows the Capture state so that test data or status information can be shifted out or new data shifted in. Following the Shift state, the TAP either returns to the Run-Test/Idle state via the Exit1 and Update states or enters the Pause state via Exit1. The Pause state is used to temporarily suspend the shifting of data through either the Data or Instruction Register while an external operation is performed. From the Pause state, shifting can resume by reentering the Shift state via the Exit2 state or be terminated by entering the Run-Test/Idle state via the Exit2 and Update states. If the proper instruction is shifted in during a Shift-IR operation, the next entry into Run-Test/Idle initiates the test mode (steady state = test). This is when the device is actually programmed, erased or verified. All other instructions are executed in the Update state.

## Test Instructions

Like data registers, the IEEE 1149.1 standard also mandates the inclusion of certain instructions. It outlines the function of three required and six optional instructions. Any additional instructions are left exclusively for the manufacturer to determine. The instruction word length is not mandated other than to be a minimum of two bits, with only the BYPASS and EXTEST instruction code patterns being specifically called out (all ones and all zeroes respectively). The ispPAC-POWR1220AT8 contains the required minimum instruction set as well as one from the optional instruction set. In addition, there are several proprietary instructions that allow the device to be configured and verified. Table 13 lists the instructions supported by the ispPAC-POWR1220AT8 JTAG Test Access Port (TAP) control-

ler:

**Table 13. ispPAC-POWR1220AT8 TAP Instruction Table**

Instruction	Command Code	Comments
BULK_ERASE	0000 0011	Bulk erase device
BYPASS	1111 1111	Bypass - connect TDO to TDI
DISCHARGE	0001 0100	Fast VPP discharge
ERASE_DONE_BIT	0010 0100	Erases 'Done' bit only
EXTEST	0000 0000	Bypass - connect TDO to TDI
IDCODE	0001 0110	Read contents of manufacturer ID code (32 bits)
OUTPUTS_HIGHZ	0001 1000	Force all outputs to High-Z state, FET outputs pulled low
SAMPLE/PRELOAD	00011100	Sample/Preload. Default to bypass.
PROGRAM_DISABLE	0001 1110	Disable program mode
PROGRAM_DONE_BIT	0010 1111	Programs the Done bit
PROGRAM_ENABLE	0001 0101	Enable program mode
PROGRAM_SECURITY	0000 1001	Program security fuse
RESET	0010 0010	Resets device (refer to the RESETb Signal, RESET Command via JTAG or I <sup>2</sup> C section of this data sheet)
IN1_RESET_JTAG_BIT	0001 0010	Reset the JTAG bit associated with IN1 pin to 0
IN1_SET_JTAG_BIT	0001 0011	Set the JTAG bit associated with IN1 pin to 1
CFG_ADDRESS	0010 1011	Select non-PLD address register
CFG_DATA_SHIFT	0010 1101	Non-PLD data shift
CFG_ERASE	0010 1001	ERASE Just the Non PLD configuration
CFG_PROGRAM	0010 1110	Non-PLD program
CFG_VERIFY	0010 1000	VRIFY non-PLD fusemap data
PLD_ADDRESS_SHIFT	0000 0001	PLD_Address register (169 bits)
PLD_DATA_SHIFT	0000 0010	PLD_Data register (243 Bits)
PLD_INIT_ADDR_FOR_PROG_INCR	0010 0001	Initialize the address register for auto increment
PLD_PROG_INCR	0010 0111	Program column register to E <sup>2</sup> and auto increment address register
PLD_PROGRAM	0000 0111	Program PLD data register to E <sup>2</sup>
PLD_VERIFY	0000 1010	Verifies PLD column data
PLD_VERIFY_INCR	0010 1010	Load column register from E <sup>2</sup> and auto increment address register
UES_PROGRAM	0001 1010	Program UES bits into E <sup>2</sup>
UES_READ	0001 0111	Read contents of UES register from E <sup>2</sup> (32 bits)

**BYPASS** is one of the three required instructions. It selects the Bypass Register to be connected between TDI and TDO and allows serial data to be transferred through the device without affecting the operation of the ispPAC-POWR1220AT8. The IEEE 1149.1 standard defines the bit code of this instruction to be all ones (11111111).

The required **SAMPLE/PRELOAD** instruction dictates the Boundary-Scan Register be connected between TDI and TDO. The ispPAC-POWR1220AT8 has no boundary scan register, so for compatibility it defaults to the BYPASS mode whenever this instruction is received. The bit code for this instruction is defined by Lattice as shown in Table 13.

The **EXTEST** (external test) instruction is required and would normally place the device into an external boundary test mode while also enabling the boundary scan register to be connected between TDI and TDO. Again, since the ispPAC-POWR1220AT8 has no boundary scan logic, the device is put in the BYPASS mode to ensure specification compatibility. The bit code of this instruction is defined by the 1149.1 standard to be all zeros (00000000).

The optional **IDCODE** (identification code) instruction is incorporated in the ispPAC-POWR1220AT8 and leaves it in its functional mode when executed. It selects the Device Identification Register to be connected between TDI and TDO. The Identification Register is a 32-bit shift register containing information regarding the IC manufacturer, device type and version code (Figure 40). Access to the Identification Register is immediately available, via a TAP data scan operation, after power-up of the device, or by issuing a Test-Logic-Reset instruction. The bit code for this instruction is defined by Lattice as shown in Table 13.

**Figure 40. ispPAC-POWR1220AT8 ID Code**

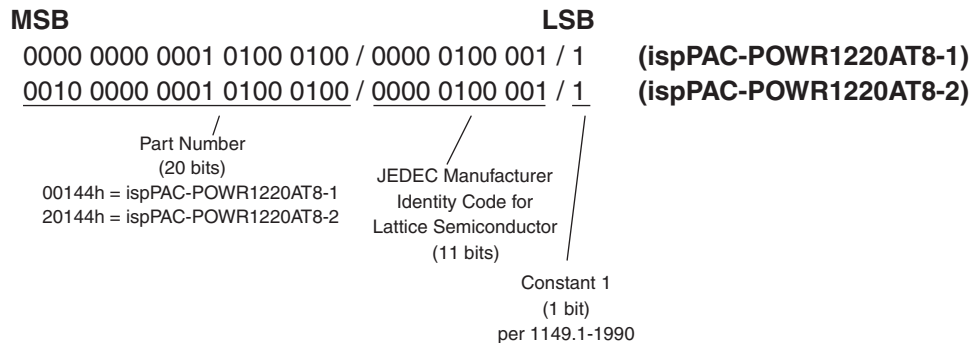

### ispPAC-POWR1220AT8 Specific Instructions

There are 25 unique instructions specified by Lattice for the ispPAC-POWR1220AT8. These instructions are primarily used to interface to the various user registers and the E<sup>2</sup>CMOS non-volatile memory. Additional instructions are used to control or monitor other features of the device. A brief description of each unique instruction is provided in detail below, and the bit codes are found in Table 13.

**PLD\_ADDRESS\_SHIFT** – This instruction is used to set the address of the PLD AND/ARCH arrays for subsequent program or read operations. This instruction also forces the outputs into the OUTPUTS\_HIGHZ.

**PLD\_DATA\_SHIFT** – This instruction is used to shift PLD data into the register prior to programming or reading. This instruction also forces the outputs into the OUTPUTS\_HIGHZ.

**PLD\_INIT\_ADDR\_FOR\_PROG\_INCR** – This instruction prepares the PLD address register for subsequent PLD\_PROG\_INCR or PLD\_VERIFY\_INCR instructions.

**PLD\_PROG\_INCR** – This instruction programs the PLD data register for the current address and increments the address register for the next set of data.

**PLD\_PROGRAM** – This instruction programs the selected PLD AND/ARCH array column. The specific column is preselected by using PLD\_ADDRESS\_SHIFT instruction. The programming occurs at the second rising edge of the TCK in Run-Test-Idle JTAG state. The device must already be in programming mode (PROGRAM\_ENABLE instruction). This instruction also forces the outputs into the OUTPUTS\_HIGHZ.

**PROGRAM\_SECURITY** – This instruction is used to program the electronic security fuse (ESF) bit. Programming the ESF bit protects proprietary designs from being read out. The programming occurs at the second rising edge of the TCK in Run-Test-Idle JTAG state. The device must already be in programming mode (PROGRAM\_ENABLE instruction). This instruction also forces the outputs into the OUTPUTS\_HIGHZ.

**PLD\_VERIFY** – This instruction is used to read the content of the selected PLD AND/ARCH array column. This specific column is preselected by using PLD\_ADDRESS\_SHIFT instruction. This instruction also forces the outputs into the OUTPUTS\_HIGHZ.

**DISCHARGE** – This instruction is used to discharge the internal programming supply voltage after an erase or programming cycle and prepares ispPAC-POWR1220AT8 for a read cycle. This instruction also forces the outputs into the OUTPUTS\_HIGHZ.

**CFG\_ADDRESS** – This instruction is used to set the address of the CFG array for subsequent program or read operations. This instruction also forces the outputs into the OUTPUTS\_HIGHZ.

**CFG\_DATA\_SHIFT** – This instruction is used to shift data into the CFG register prior to programming or reading. This instruction also forces the outputs into the OUTPUTS\_HIGHZ.

**CFG\_ERASE** – This instruction will bulk erase the CFG array. The action occurs at the second rising edge of TCK in Run-Test-Idle JTAG state. The device must already be in programming mode (PROGRAM\_ENABLE instruction). This instruction also forces the outputs into the OUTPUTS\_HIGHZ.

**CFG\_PROGRAM** – This instruction programs the selected CFG array column. This specific column is preselected by using CFG\_ADDRESS instruction. The programming occurs at the second rising edge of the TCK in Run-Test-Idle JTAG state. The device must already be in programming mode (PROGRAM\_ENABLE instruction). This instruction also forces the outputs into the OUTPUTS\_HIGHZ.

**CFG\_VERIFY** – This instruction is used to read the content of the selected CFG array column. This specific column is preselected by using CFG\_ADDRESS instruction. This instruction also forces the outputs into the OUTPUTS\_HIGHZ.

**BULK\_ERASE** – This instruction will bulk erase all E<sup>2</sup>CMOS bits (CFG, PLD, UES, and ESF) in the ispPAC-POWR1220AT8. The device must already be in programming mode (PROGRAM\_ENABLE instruction). This instruction also forces the outputs into the OUTPUTS\_HIGHZ.

**OUTPUTS\_HIGHZ** – This instruction turns off all of the open-drain output transistors. Pins that are programmed as FET drivers will be placed in the active low state. This instruction is effective after Update-Instruction-Register JTAG state.

**PROGRAM\_ENABLE** – This instruction enables the programming mode of the ispPAC-POWR1220AT8. This instruction also forces the outputs into the OUTPUTS\_HIGHZ.

**IDCODE** – This instruction connects the output of the Identification Code Data Shift (IDCODE) Register to TDO (Figure 41), to support reading out the identification code.

**Figure 41. IDCODE Register**

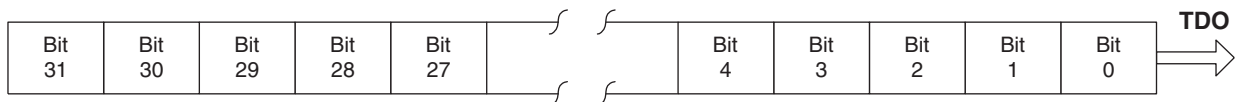

**PROGRAM\_DISABLE** – This instruction disables the programming mode of the ispPAC-POWR1220AT8. The Test-Logic-Reset JTAG state can also be used to cancel the programming mode of the ispPAC-POWR1220AT8.

**UES\_READ** – This instruction both reads the E<sup>2</sup>CMOS bits into the UES register and places the UES register between the TDI and TDO pins (as shown in Figure 42), to support programming or reading of the user electronic signature bits.

**Figure 42. UES Register**

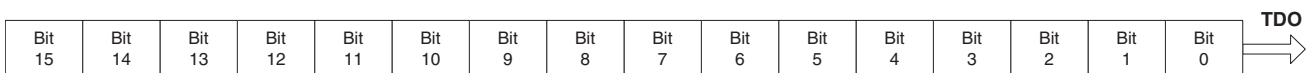

**UES\_PROGRAM** – This instruction will program the content of the UES Register into the UES E<sup>2</sup>CMOS memory. The device must already be in programming mode (PROGRAM\_ENABLE instruction). This instruction also forces the outputs into the OUTPUTS\_HIGHZ.

**ERASE\_DONE\_BIT** – This instruction clears the 'Done' bit, which prevents the ispPAC-POWR1220AT8 sequence from starting.

**PROGRAM\_DONE\_BIT** – This instruction sets the 'Done' bit, which enables the ispPAC-POWR1220AT8 sequence to start.

**RESET** – This instruction resets the PLD sequence and output macrocells.

**IN1\_RESET\_JTAG\_BIT** – This instruction clears the JTAG Register logic input 'IN1.' The PLD input has to be configured to take input from the JTAG Register in order for this command to have effect on the sequence.

**IN1\_SET\_JTAG\_BIT** – This instruction sets the JTAG Register logic input 'IN1.' The PLD input has to be configured to take input from the JTAG Register in order for this command to have effect on the sequence.

**PLD\_VERIFY\_INCR** – This instruction reads out the PLD data register for the current address and increments the address register for the next read.

**Notes:**

In all of the descriptions above, OUTPUTS\_HIGHZ refers both to the instruction and the state of the digital output pins, in which the open-drains are tri-stated and the FET drivers are pulled low.

Before any of the above programming instructions are executed, the respective E<sup>2</sup>CMOS bits need to be erased using the corresponding erase instruction.

# Package Diagrams

## 100-Pin TQFP

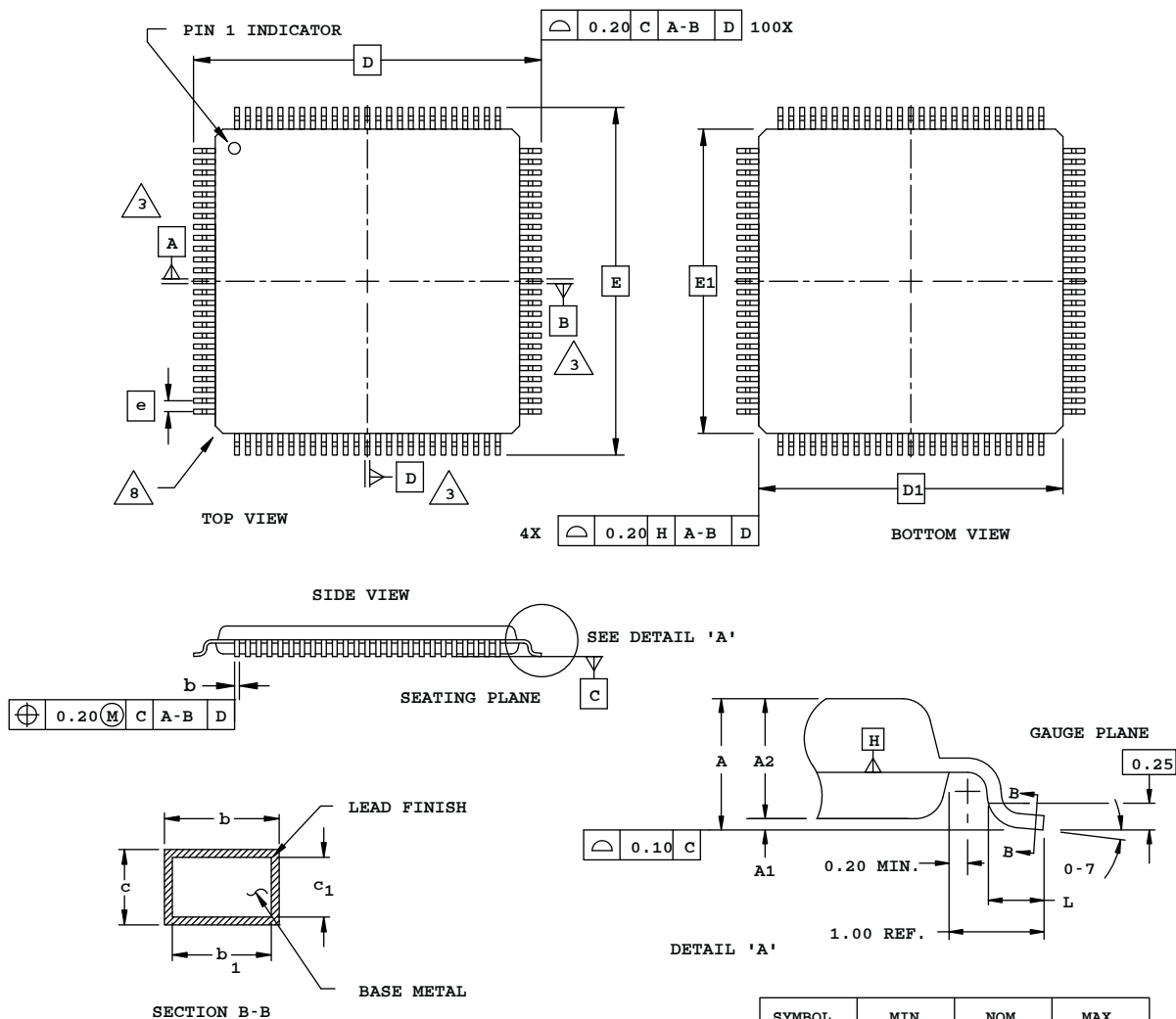

**NOTES:**

1. DIMENSIONING AND TOLERANCING PER ANSI Y14.5 - 1982.
2. ALL DIMENSIONS ARE IN MILLIMETERS.
3. DATUMS A, B AND D TO BE DETERMINED AT DATUM PLANE H.
4. DIMENSIONS D1 AND E1 DO NOT INCLUDE MOLD PROTRUSION. ALLOWABLE MOLD PROTRUSION IS 0.254 MM ON D1 AND E1 DIMENSIONS.
5. THE TOP OF PACKAGE MAY BE SMALLER THAN THE BOTTOM OF THE PACKAGE BY 0.15 MM.
6. SECTION B-B:  
THESE DIMENSIONS APPLY TO THE FLAT SECTION OF THE LEAD BETWEEN 0.10 AND 0.25 MM FROM THE LEAD TIP.
7. A1 IS DEFINED AS THE DISTANCE FROM THE SEATING PLANE TO THE LOWEST POINT ON THE PACKAGE BODY.
8. EXACT SHAPE OF EACH CORNER IS OPTIONAL.

SYMBOL	MIN.	NOM.	MAX.
A	-	-	1.60
A1	0.05	-	0.15
A2	1.35	1.40	1.45
D	16.00 BSC		
D1	14.00 BSC		
E	16.00 BSC		
E1	14.00 BSC		
L	0.45	0.60	0.75
N	100		
e	0.50 BSC		
b	0.17	0.22	0.27
b1	0.17	0.20	0.23
c	0.09	0.15	0.20
c1	0.09	0.13	0.16

## Part Number Description

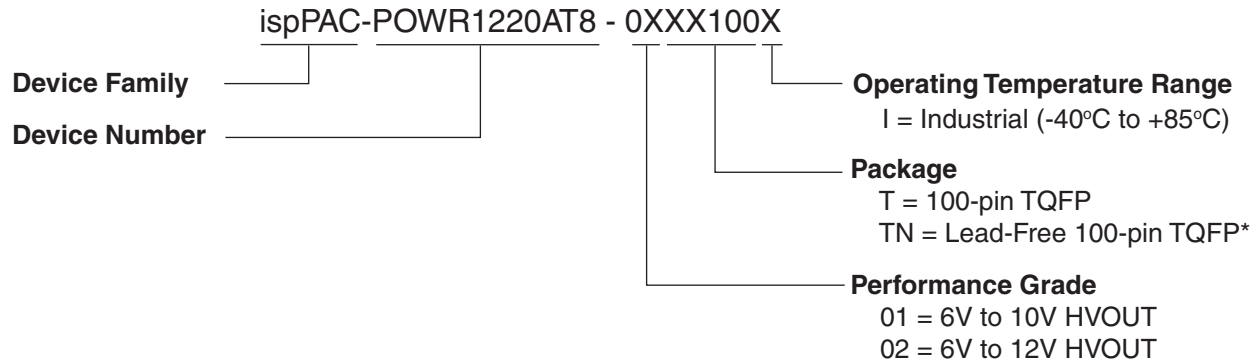

## ispPAC-POWR1220AT8 Ordering Information

### Conventional Packaging

Part Number	Package	Pins
ispPAC-POWR1220AT8-01T100I	TQFP	100
ispPAC-POWR1220AT8-02T100I	TQFP	100

### Lead-Free Packaging

Part Number	Package	Pins
ispPAC-POWR1220AT8-01TN100I	Lead-Free TQFP	100
ispPAC-POWR1220AT8-02TN100I	Lead-Free TQFP	100

**Package Options**

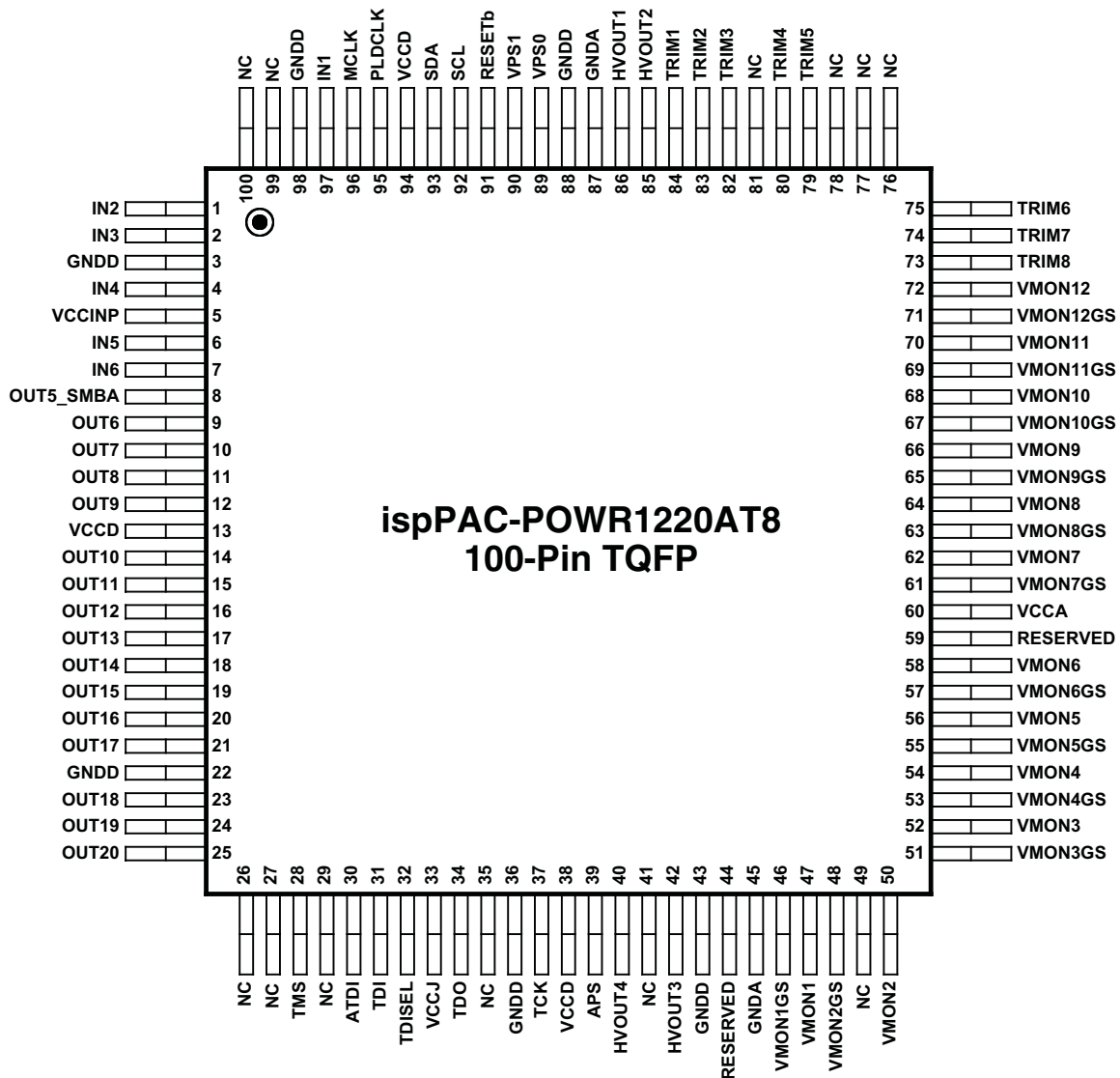

**Technical Support Assistance**

e-mail: [isppacs@latticesemi.com](mailto:isppacs@latticesemi.com)

Internet: [www.latticesemi.com](http://www.latticesemi.com)

## Revision History

Date	Version	Change Summary
October 2005	1.0	Initial release.
March 2006	1.1	Pin Descriptions table, note 4: Clarification for un-used VMON pins to be tied to GNDD.
		Correction for I <sup>2</sup> C/ADC calculation.
May 2006	1.2	Updated HVOOUT I <sub>source</sub> range: 12.5μA to 100μA.
		ADC Characteristics table, ADC Conversion Time: added entry for T <sub>convert</sub> = 200 μs.
		Added footnotes for I <sup>2</sup> C frequency.
		Figure 13, I <sub>source</sub> 12.5μA to 100μA.
		Clarified operation of ADC conversions.
		TAP instructions, added JTAG SAMPLE/PRELOAD instruction and notes for all JTAG instructions
October 2006	1.3	Data sheet status changed to "final".
		Analog Specifications table, lowered Max. I <sub>cc</sub> to 40 mA.
		Voltage Monitors table, tightened Input Resistor Variation to 15%.
		Margin Trim DAC Output Characteristics table, increased Max. DAC output current to +/- 200 μA.
		AC/Transient Characteristics table, tightened Internal Oscillator frequency variation down to 5%.
Digital Specifications table, included V <sub>IL</sub> and V <sub>IH</sub> specifications for I <sup>2</sup> C interface.		
August 2007	01.4	Changes to HVOOUT pin specifications.
June 2008	01.5	Added timing diagram and timing parameters to "Power-On Reset" specifications.
		Modified PLD Architecture figure to show input registers.
		Updated I <sup>2</sup> C Control Registers table.
		VCCPROG pin usage clarification added.
May 2010	01.6	VCCPROG pin usage further clarified.
		Added product information for ispPAC-POWR1220AT8-02.
		T <sub>GOOD</sub> changed from a MIN to a MAX. ispPAC-POWR1220AT8 Alternate TDI Configuration Diagram clarified.
February 2012	01.7	Updated document with new corporate logo.
September 2012	01.8	Pin Descriptions table – Updated voltage range for Pin 5, VCCINP.
September 2013	01.9	Renamed VCCPROG pin APS. Updated voltage range for TADC Error.
		Added the ispPAC-POWR1220AT8 JTAG Interconnection Configuration Diagram (Figure 34).
		Changed the ispPAC-POWR1220AT8 Alternate TDI Configuration Diagram figure to ispPAC-POWR1220AT8 Alternate Configuration Diagram (Figure 35).
		Updated Technical Support Assistance information.

## Looking for pricing, stock, or lifecycle information?

Click below to explore more details on WIN SOURCE:

- ⊖ [View ISPPAC-POWR1220AT8-01TN100I on WIN SOURCE](#)
- ⊖ [Lattice Semiconductor Corporation Information](#)

## Optimize Your Supply Chain with WIN SOURCE Solutions

- ✓ Global Sourcing Solution
- ✓ Obsolete Management
- ✓ Cost Control Management
- ✓ Shortage Management
- ✓ Alternative Solution
- ✓ Excess Inventory Management