

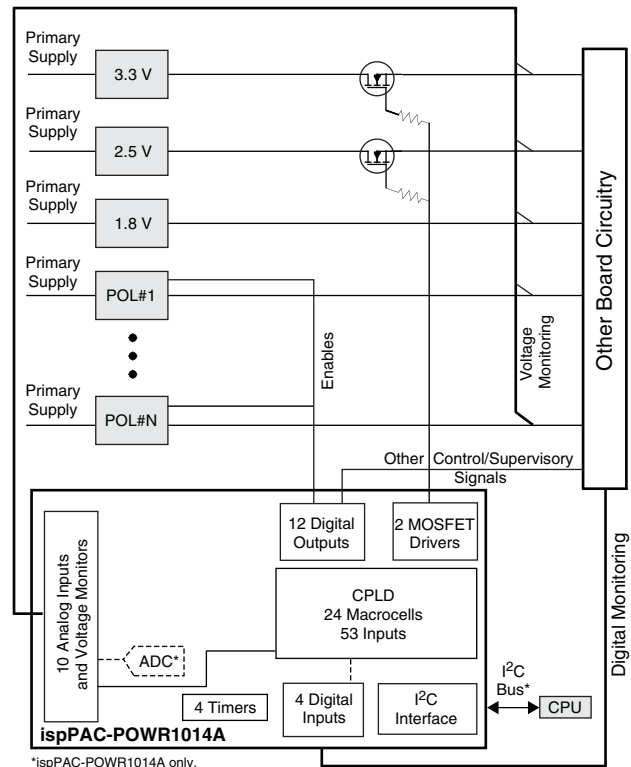

## Features

- Monitor and Control Multiple Power Supplies**
  - Simultaneously monitors up to 10 power supplies
  - Provides up to 14 output control signals
  - Programmable digital and analog circuitry
- Embedded PLD for Sequence Control**
  - 24-macrocell CPLD implements both state machines and combinatorial logic functions
- Embedded Programmable Timers**
  - Four independent timers
  - 32µs to 2 second intervals for timing sequences
- Analog Input Monitoring**
  - 10 independent analog monitor inputs
  - Two programmable threshold comparators per analog input
  - Hardware window comparison
  - 10-bit ADC for I<sup>2</sup>C monitoring (ispPAC-POWR1014A only)
- High-Voltage FET Drivers**
  - Power supply ramp up/down control
  - Programmable current and voltage output
  - Independently configurable for FET control or digital output
- 2-Wire (I<sup>2</sup>C/SMBus™ Compatible) Interface**
  - Comparator status monitor
  - ADC readout
  - Direct control of inputs and outputs
  - Power sequence control
  - Only available with ispPAC-POWR1014A
- 3.3 V Operation, Wide Supply Range 2.8 V to 3.96 V**
  - Industrial temperature range: -40°C to +85°C
  - 48-pin TQFP package, lead-free option
- Multi-Function JTAG Interface**
  - In-system programming
  - Access to all I<sup>2</sup>C registers
  - Direct input control

## Application Block Diagram



## Description

Lattice's Power Manager II ispPAC-POWR1014/A is a general-purpose power-supply monitor and sequence controller, incorporating both in-system programmable logic and in-system programmable analog functions implemented in non-volatile E<sup>2</sup>CMOS® technology. The ispPAC-POWR1014/A device provides 10 independent analog input channels to monitor up to 10 power supply test points. Each of these input channels has two independently programmable comparators to support both high/low and in-bounds/out-of-bounds (window-compare) monitor functions. Four general-purpose digital inputs are also provided for miscellaneous control functions.

The ispPAC-POWR1014/A provides 14 open-drain digital outputs that can be used for controlling DC-DC converters, low-drop-out regulators (LDOs) and optocouplers, as well as for supervisory and general-purpose logic interface functions. Two of these outputs (HVOUT1-HVOUT2) may be configured as high-voltage

MOSFET drivers. In high-voltage mode these outputs can provide up to 12 V for driving the gates of n-channel MOSFETs so that they can be used as high-side power switches controlling the supplies with a programmable ramp rate for both ramp up and ramp down.

The ispPAC-POWR1014/A incorporates a 24-macrocell CPLD that can be used to implement complex state machine sequencing for the control of multiple power supplies as well as combinatorial logic functions. The status of all of the comparators on the analog input channels as well as the general purpose digital inputs are used as inputs by the CPLD array, and all digital outputs may be controlled by the CPLD. Four independently programmable timers can create delays and time-outs ranging from 32  $\mu$ s to 2 seconds. The CPLD is programmed using Logi-Builder™, an easy-to-learn language integrated into the PAC-Designer® software. Control sequences are written to monitor the status of any of the analog input channel comparators or the digital inputs.

The on-chip 10-bit A/D converter is used to monitor the  $V_{MON}$  voltage through the I<sup>2</sup>C bus or JTAG interface of the ispPAC-POWR1014A device.

The I<sup>2</sup>C bus/SMBus interface allows an external microcontroller to measure the voltages connected to the  $V_{MON}$  inputs, read back the status of each of the  $V_{MON}$  comparator and PLD outputs, control logic signals IN2 to IN4 and control the output pins (ispPAC-POWR1014A only). The JTAG interface can be used to read out all I<sup>2</sup>C registers during manufacturing.

**Figure 1. ispPAC-POWR1014/A Block Diagram**

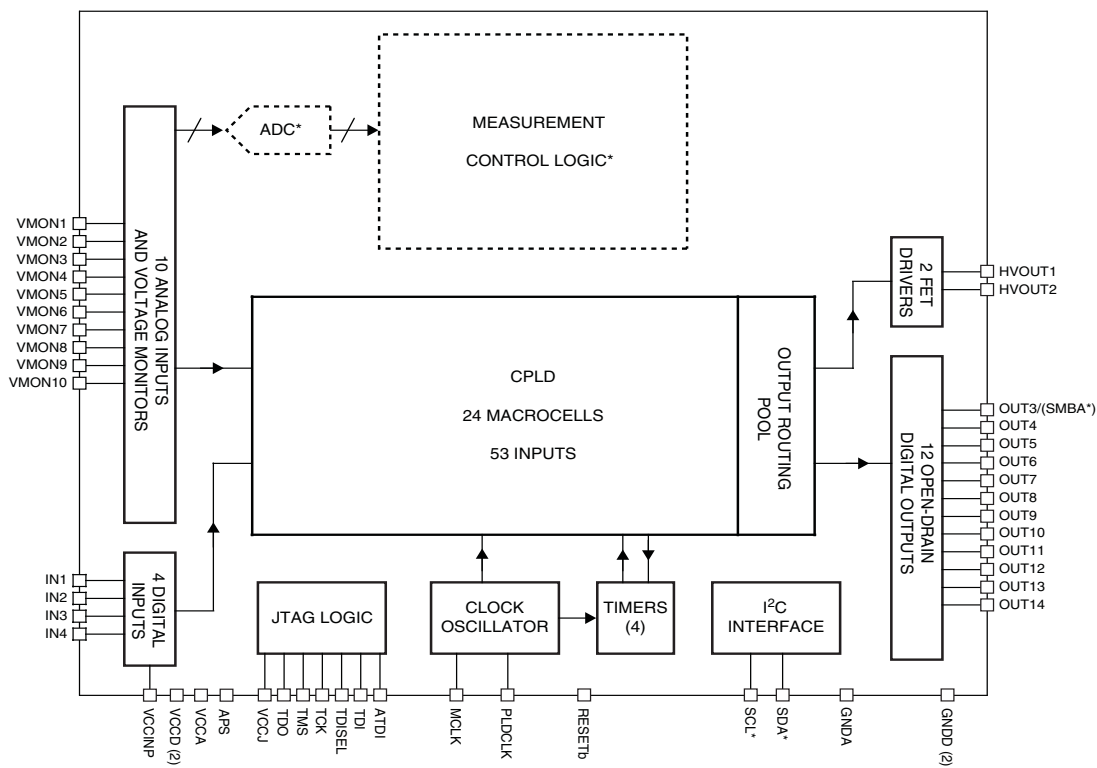

\*ispPAC-POWR1014A only.

## Pin Descriptions

Number	Name	Pin Type	Voltage Range	Description
44	IN1	Digital Input	VCCINP <sup>1,2</sup>	PLD Logic Input 1 Registered by MCLK
46	IN2	Digital Input	VCCINP <sup>1,3</sup>	PLD Logic Input 2 Registered by MCLK
47	IN3	Digital Input	VCCINP <sup>1,3</sup>	PLD Logic Input 3 Registered by MCLK
48	IN4	Digital Input	VCCINP <sup>1,3</sup>	PLD Logic Input 4 Registered by MCLK
25	VMON1 <sup>11</sup>	Analog Input	-0.3 V to 5.87 V	Voltage Monitor 1 Input
26	VMON2 <sup>11</sup>	Analog Input	-0.3 V to 5.87 V	Voltage Monitor 2 Input
27	VMON3 <sup>11</sup>	Analog Input	-0.3 V to 5.87 V	Voltage Monitor 3 Input
28	VMON4 <sup>11</sup>	Analog Input	-0.3 V to 5.87 V	Voltage Monitor 4 Input
32	VMON5 <sup>11</sup>	Analog Input	-0.3 V to 5.87 V	Voltage Monitor 5 Input
33	VMON6 <sup>11</sup>	Analog Input	-0.3 V to 5.87 V	Voltage Monitor 6 Input
34	VMON7 <sup>11</sup>	Analog Input	-0.3 V to 5.87 V	Voltage Monitor 7 Input
35	VMON8 <sup>11</sup>	Analog Input	-0.3 V to 5.87 V	Voltage Monitor 8 Input
36	VMON9 <sup>11</sup>	Analog Input	-0.3 V to 5.87 V	Voltage Monitor 9 Input
37	VMON10 <sup>11</sup>	Analog Input	-0.3 V to 5.87 V	Voltage Monitor 10 Input
7, 31	GNDD <sup>4</sup>	Ground	Ground	Digital Ground
30	GNDA <sup>4</sup>	Ground	Ground	Analog Ground
41, 23	VCCD <sup>5</sup>	Power	2.8 V to 3.96 V	Core VCC, Main Power Supply
29	VCCA <sup>5</sup>	Power	2.8 V to 3.96 V	Analog Power Supply
45	VCCINP	Power	2.25 V to 5.5 V	VCC for IN[1:4] Inputs
20	VCCJ	Power	2.25 V to 3.6 V	VCC for JTAG Logic Interface Pins
24	APS <sup>9</sup>	Alternate Programming Supply	3.0 V to 3.6 V	Alternate E <sup>2</sup> Programming Supply; use only when the Device is Not Powered by V <sub>CCD</sub> and V <sub>CCA</sub> .
15	HVOUT1	Open Drain Output <sup>6</sup>	0 V to 13 V	Open-Drain Output 1
		Current Source/Sink	12.5 $\mu$ A to 100 $\mu$ A Source 100 $\mu$ A to 3000 $\mu$ A Sink	High-voltage FET Gate Driver 1
14	HVOUT2	Open Drain Output <sup>6</sup>	0 V to 13 V	Open-Drain Output 2
		Current Source/Sink	12.5 $\mu$ A to 100 $\mu$ A Source 100 $\mu$ A to 3000 $\mu$ A Sink	High-voltage FET Gate Driver 2
13	SMBA_OUT <sub>3</sub>	Open Drain Output <sup>6</sup>	0 V to 5.5 V	Open-Drain Output 3, (SMBUS Alert Active Low, ispPAC-POWR1014A only).
12	OUT4	Open Drain Output <sup>6</sup>	0 V to 5.5 V	Open-Drain Output 4
11	OUT5	Open Drain Output <sup>6</sup>	0 V to 5.5 V	Open-Drain Output 5
10	OUT6	Open Drain Output <sup>6</sup>	0 V to 5.5 V	Open-Drain Output 6
9	OUT7	Open Drain Output <sup>6</sup>	0 V to 5.5 V	Open-Drain Output 7
8	OUT8	Open Drain Output <sup>6</sup>	0 V to 5.5 V	Open-Drain Output 8
6	OUT9	Open Drain Output <sup>6</sup>	0 V to 5.5 V	Open-Drain Output 9
5	OUT10	Open Drain Output <sup>6</sup>	0 V to 5.5 V	Open-Drain Output 10
4	OUT11	Open Drain Output <sup>6</sup>	0 V to 5.5 V	Open-Drain Output 11
3	OUT12	Open Drain Output <sup>6</sup>	0 V to 5.5 V	Open-Drain Output 12
2	OUT13	Open Drain Output <sup>6</sup>	0 V to 5.5 V	Open-Drain Output 13
1	OUT14	Open Drain Output <sup>6</sup>	0 V to 5.5 V	Open-Drain Output 14
40	RESETb <sup>7</sup>	Digital I/O	0 V to 3.96 V	Device Reset (Active Low) Pin internally pulled up.

## Pin Descriptions (Cont.)

Number	Name	Pin Type	Voltage Range	Description
42	PLDCLK	Digital Output	0 V to 3.96 V	250kHz PLD Clock Output (Tristate), CMOS Output Pin internally pulled up.
43	MCLK	Digital I/O	0 V to 3.96 V	8MHz Clock I/O (Tristate), CMOS Drive. Pin internally pulled up.
21	TDO	Digital Output	0 V to 5.5 V	JTAG Test Data Out
22	TCK	Digital Input	0 V to 5.5 V	JTAG Test Clock Input
16	TMS	Digital Input	0 V to 5.5 V	JTAG Test Mode Select Pin internally pulled up.
18	TDI	Digital Input	0 V to 5.5 V	JTAG Test Data In, TDISEL pin = 1. Pin internally pulled up.
17	ATDI	Digital Input	0 V to 5.5 V	JTAG Test Data In (Alternate), TDISEL Pin = 0. Pin internally pulled up.
19	TDISEL	Digital Input	0 V to 5.5 V	Select TDI/ATDI Input Pin internally pulled up.
39	SCL <sup>8, 10</sup>	Digital Input	0 V to 5.5 V	I <sup>2</sup> C Serial Clock Input (ispPAC-POWR1014A Only)
38	SDA <sup>8, 10</sup>	Digital I/O	0 V to 5.5 V	I <sup>2</sup> C Serial Data, Bi-directional Pin, Open Drain (ispPAC-POWR1014A Only)

- [IN1...IN4] are inputs to the PLD. The thresholds for these pins are referenced by the voltage on VCCINP. Unused INx inputs should be tied to GNDD.
- IN1 pin can also be controlled through JTAG interface.
- [IN2..IN4] can also be controlled through I<sup>2</sup>C/SMBus interface (ispPAC-POWR1014A only).
- GNDA and GNDD pins must be connected together on the circuit board.
- VCCD and VCCA pins must be connected together on the circuit board.
- Open-drain outputs require an external pull-up resistor to a supply.
- The RESETb pin should only be used for cascading two or more ispPAC-POWR 1014/A devices, and be left open otherwise. Refer to the Power-ON Reset section of AN6075, [Powering Up and Programming the ispPAC-POWR1014/A](#).
- These pins should be connected to GNDD (ispPAC-POWR1014 only).
- The APS pin MUST be left floating when V<sub>CCD</sub> and V<sub>CCA</sub> are powered.
- SCL should be tied high and SDA is don't care when I<sup>2</sup>C registers are accessed through the JTAG interface (ispPAC-POWR1014A only).
- The VMON inputs can be biased independently from VCC. Unused VMON inputs should be tied to GND.

## Absolute Maximum Ratings

Absolute maximum ratings are shown in the table below. Stresses beyond those listed may cause permanent damage to the device. Functional operation of the device at these or any other conditions beyond those indicated in the recommended operating conditions of this specification is not implied.

Symbol	Parameter	Conditions	Min.	Max.	Units
$V_{CCD}$	Core supply		-0.5	4.5	V
$V_{CCA}$	Analog supply		-0.5	4.5	V
$V_{CCINP}$	Digital input supply (IN[1:4])		-0.5	6	V
$V_{CCJ}$	JTAG logic supply		-0.5	6	V
APS	Alternate E <sup>2</sup> programming supply		-0.5	4	V
$V_{IN}$	Digital input voltage (all digital I/O pins)		-0.5	6	V
$V_{MON}$	$V_{MON}$ input voltage		-0.5	6	V
$V_{TRI}$	Voltage applied to tri-stated pins	HVOUT[1:2]	-0.5	13.3	V
		OUT[3:14]	-0.5	6	V
$I_{SINKMAXTOTAL}$	Maximum sink current on any output			23	mA
$T_S$	Storage temperature		-65	150	°C
$T_A$	Ambient temperature		-65	125	°C

## Recommended Operating Conditions

Symbol	Parameter	Conditions	Min.	Max.	Units
$V_{CCD}, V_{CCA}$	Core supply voltage at pin		2.8	3.96	V
$V_{CCINP}$	Digital input supply for IN[1:4] at pin		2.25	5.5	V
$V_{CCJ}$	JTAG logic supply voltage at pin		2.25	3.6	V
APS	Alternate E <sup>2</sup> programming supply at pin	$V_{CCD}$ and $V_{CCA}$ powered	No connect Must be left floating		V
		$V_{CCD}$ and $V_{CCA}$ not powered	3.0	3.6	V
$V_{IN}$	Input voltage at digital input pins		-0.3	5.5	V
$V_{MON}$	Input voltage at $V_{MON}$ pins		-0.3	5.9	V
$V_{OUT}$	Open-drain output voltage	OUT[3:14] pins	-0.3	5.5	V
		HVOUT[1:2] pins in open-drain mode	-0.3	13.0	V
$T_{APROG}$	Ambient temperature during programming		-40	85	°C
$T_A$	Ambient temperature	Power applied	-40	85	°C

## ESD Performance

Pin Group	ESD Stress	Min.	Units
All pins	HBM	2000	V
	CDM	1000	V

## Analog Specifications

Symbol	Parameter	Conditions	Min.	Typ.	Max.	Units
$I_{CC}^1$	Supply current				20	mA
$I_{CCINP}$	Supply current				5	mA
$I_{CCJ}$	Supply current				1	mA
$I_{CCPROG}$	Supply current	During programming cycle			20	mA

1. Includes currents on  $V_{CCD}$  and  $V_{CCA}$  supplies.

## Voltage Monitors

Symbol	Parameter	Conditions	Min.	Typ.	Max.	Units
$R_{IN}$	Input resistance		55	65	75	k $\Omega$
$C_{IN}$	Input capacitance			8		pF
$V_{MON}$ Range	Programmable trip-point range		0.075		5.867	V
$V_Z$ Sense	Near-ground sense threshold		70	75	80	mV
$V_{MON}$ Accuracy	Absolute accuracy of any trip-point <sup>1</sup>			0.3	0.9	%
HYST	Hysteresis of any trip-point (relative to setting)			1		%

1. Guaranteed by characterization across  $V_{CCA}$  range, operating temperature, process.

## High Voltage FET Drivers

Symbol	Parameter	Conditions	Min.	Typ.	Max.	Units
$V_{PP}$	Gate driver output voltage	12 V setting <sup>1</sup>	11.5	12	12.5	V
		10 V setting	9.6	10	10.4	
		8 V setting	7.7	8	8.3	
		6 V setting	5.8	6	6.2	
$I_{OUTSRC}$	Gate driver source current (HIGH state)	Four settings in software		12.5		$\mu$ A
				25		
				50		
				100		
$I_{OUTSINK}$	Gate driver sink current (LOW state)	FAST OFF mode	2000	3000		$\mu$ A
		Controlled ramp settings		100		
				250		
			500			

1. 12 V setting only available on ispPAC-POWR1014-02 and ispPAC-POWR1014A-02.

## ADC Characteristics<sup>1</sup>

Symbol	Parameter	Conditions	Min.	Typ.	Max.	Units
	ADC resolution			10		Bits
T <sub>CONVERT</sub>	Conversion time	Time from I <sup>2</sup> C request			100	μs
V <sub>IN</sub>	Input range full scale	Programmable attenuator = 1	0		2.048	V
		Programmable attenuator = 3	0		5.9 <sup>2</sup>	V
ADC Step Size	LSB	Programmable attenuator = 1		2		mV
		Programmable attenuator = 3		6		mV
E <sub>attenuator</sub>	Error due to attenuator	Programmable attenuator = 3		+/- 0.1		%

1. ispPAC-POWR1014A only.
2. Maximum voltage is limited by V<sub>MONX</sub> pin (theoretical maximum is 6.144V).

## ADC Error Budget Across Entire Operating Temperature Range<sup>1</sup>

Symbol	Parameter	Conditions	Min.	Typ.	Max.	Units
T <sub>ADC Error</sub>	Total Measurement Error at Any Voltage <sup>2</sup>	Measurement Range 600 mV - 2.048 V, Attenuator = 1	-8	+/-4	8	mV
		Measurement Range Zero to 600 mV, Attenuator = 1		+/-10		mV

1. ispPAC-POWR1014A only.
2. Total error, guaranteed by characterization, includes INL, DNL, Gain, Offset, and PSR specs of the ADC.

## Power-On Reset

Symbol	Parameter	Conditions	Min.	Typ.	Max.	Units
T <sub>RST</sub>	Delay from V <sub>TH</sub> to start-up state				100	μs
T <sub>START</sub>	Delay from RESETb HIGH to PLDCLK rising edge			5	10	μs
T <sub>GOOD</sub>	Power-on reset to valid V <sub>MON</sub> comparator output and AGOOD is true				500	μs
T <sub>BRO</sub>	Minimum duration brown out required to trigger RESETb		1		5	μs
T <sub>POR</sub>	Delay from brown out to reset state.				11	μs
V <sub>TL</sub>	Threshold below which RESETb is LOW <sup>1</sup>				2.3	V
V <sub>TH</sub>	Threshold above which RESETb is HIGH <sup>1</sup>		2.7			V
V <sub>T</sub>	Threshold above which RESETb is valid <sup>1</sup>		0.8			V
C <sub>L</sub>	Capacitive load on RESETb for master/slave operation				200	pF

1. Corresponds to V<sub>CCA</sub> and V<sub>CCD</sub> supply voltages.

Figure 2. ispPAC-POWR1014/A Power-On Reset

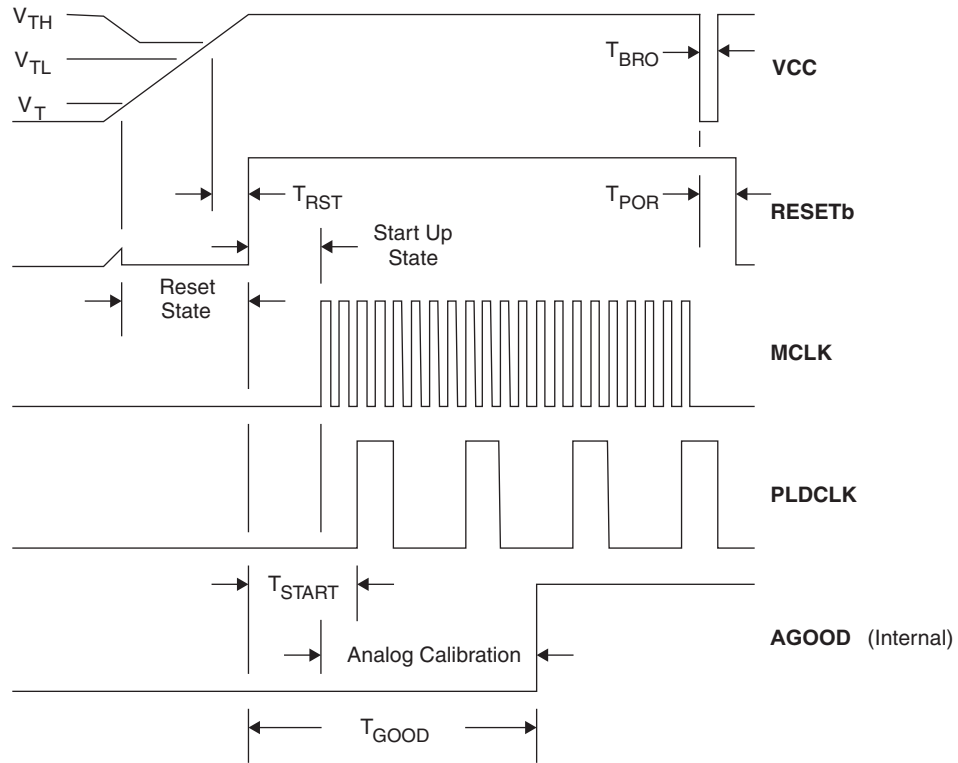

## AC/Transient Characteristics

### Over Recommended Operating Conditions

Symbol	Parameter	Conditions	Min.	Typ.	Max.	Units
<b>Voltage Monitors</b>						
$t_{PD16}$	Propagation delay input to output glitch filter OFF			16		$\mu$ s
$t_{PD64}$	Propagation delay input to output glitch filter ON			64		$\mu$ s
<b>Oscillators</b>						
$f_{CLK}$	Internal master clock frequency (MCLK)		7.6	8	8.4	MHz
$f_{CLKEXT}$	Externally applied master clock (MCLK)		7.2		8.8	MHz
$f_{PLDCLK}$	PLDCLK output frequency	$f_{CLK} = 8\text{MHz}$		250		kHz
<b>Timers</b>						
Timeout Range	Range of programmable timers (128 steps)	$f_{CLK} = 8\text{MHz}$	0.032		1966	ms
Resolution	Spacing between available adjacent timer intervals				13	%
Accuracy	Timer accuracy	$f_{CLK} = 8\text{MHz}$	-6.67		-12.5	%

## Digital Specifications

### Over Recommended Operating Conditions

Symbol	Parameter	Conditions	Min.	Typ.	Max.	Units
$I_{IL}, I_{IH}$	Input leakage, no pull-up/pull-down				+/-10	$\mu\text{A}$
$I_{OH}, I_{HVOUT}$	Output leakage current	HVOUT[1:2] in open drain mode and pulled up to 10 V		35	60	$\mu\text{A}$
		HVOUT[1:2] in open drain mode and pulled up to 13 V		35	100	$\mu\text{A}$
$I_{PU}$	Input pull-up current (TMS, TDI, TDISEL, ATDI, MCLK, PLDCLK, RESETb)			70		$\mu\text{A}$
$V_{IL}$	Voltage input, logic low <sup>1</sup>	TDI, TMS, ATDI, TDISEL, 3.3 V supply			0.8	V
		TDI, TMS, ATDI, TDISEL, 2.5 V supply			0.7	
		SCL, SDA			30% $V_{CCD}$	
		IN[1:4]			30% $V_{CCINP}$	
$V_{IH}$	Voltage input, logic high <sup>1</sup>	TDI, TMS, ATDI, TDISEL, 3.3 V supply	2.0			V
		TDI, TMS, ATDI, TDISEL, 2.5 V supply	1.7			
		SCL, SDA	70% $V_{CCD}$		$V_{CCD}$	
		IN[1:4]	70% $V_{CCINP}$		$V_{CCINP}$	
$V_{OL}$	HVOUT[1:2] (open drain mode),	$I_{SINK} = 10 \text{ mA}$			0.8	V
	OUT[3:14]	$I_{SINK} = 20 \text{ mA}$			0.8	
	TDO, MCLK, PLDCLK, SDA	$I_{SINK} = 4 \text{ mA}$			0.4	
$V_{OH}$	TDO, MCLK, PLDCLK	$I_{SRC} = 4 \text{ mA}$			$V_{CCD} - 0.4$	V
$I_{SINKTOTAL}^2$	All digital outputs				67	mA

1. IN[1:4] referenced to  $V_{CCINP}$ ; TDO, TDI, TMS, ATDI, TDISEL referenced to  $V_{CCJ}$ ; SCL, SDA referenced to  $V_{CCD}$ .

2. Sum of maximum current sink from all digital outputs combined. Reliable operation is not guaranteed if this value is exceeded.

## I<sup>2</sup>C Port Characteristics<sup>1</sup>

Symbol	Definition	100 kHz		400 kHz		Units
		Min.	Max.	Min.	Max.	
F <sub>I<sup>2</sup>C</sub>	I <sup>2</sup> C clock/data rate		100 <sup>2</sup>		400 <sup>2</sup>	kHz
T <sub>SU;STA</sub>	After start	4.7		0.6		μs
T <sub>HD;STA</sub>	After start	4		0.6		μs
T <sub>SU;DAT</sub>	Data setup	250		100		ns
T <sub>SU;STO</sub>	Stop setup	4		0.6		μs
T <sub>HD;DAT</sub>	Data hold; SCL= Vih_min = 2.1 V	0.3	3.45	0.3	0.9	μs
T <sub>LOW</sub>	Clock low period	4.7	10	1.3	10	μs
T <sub>HIGH</sub>	Clock high period	4		0.6		μs
T <sub>F</sub>	Fall time; 2.25 V to 0.65 V		300		300	ns
T <sub>R</sub>	Rise time; 0.65 V to 2.25 V		1000		300	ns
T <sub>TIMEOUT</sub>	Detect clock low timeout	25	35	25	35	ms
T <sub>POR</sub>	Device must be operational after power-on reset	500		500		ms
T <sub>BUF</sub>	Bus free time between stop and start condition	4.7		1.3		μs

1. Applies to ispPAC-POWR1014A only.

2. If F<sub>I<sup>2</sup>C</sub> is less than 50 kHz, then the ADC DONE status bit is not guaranteed to be set after a valid conversion request is completed. In this case, waiting for the T<sub>CONVERT</sub> minimum time after a convert request is made is the only way to guarantee a valid conversion is ready for readout. When F<sub>I<sup>2</sup>C</sub> is greater than 50 kHz, ADC conversion complete is ensured by waiting for the DONE status bit.

## Timing for JTAG Operations

Symbol	Parameter	Conditions	Min.	Typ.	Max.	Units
$t_{\text{SPEN}}$	Program enable delay time		10	—	—	$\mu\text{s}$
$t_{\text{SPDIS}}$	Program disable delay time		30	—	—	$\mu\text{s}$
$t_{\text{HVDIS}}$	High voltage discharge time, program		30	—	—	$\mu\text{s}$
$t_{\text{HVDIS}}$	High voltage discharge time, erase		200	—	—	$\mu\text{s}$
$t_{\text{CEN}}$	Falling edge of TCK to TDO active		—	—	10	ns
$t_{\text{CDIS}}$	Falling edge of TCK to TDO disable		—	—	10	ns
$t_{\text{SU1}}$	Setup time		5	—	—	ns
$t_{\text{H}}$	Hold time		10	—	—	ns
$t_{\text{CKH}}$	TCK clock pulse width, high		20	—	—	ns
$t_{\text{CKL}}$	TCK clock pulse width, low		20	—	—	ns
$f_{\text{MAX}}$	Maximum TCK clock frequency		—	—	25	MHz
$t_{\text{CO}}$	Falling edge of TCK to valid output		—	—	10	ns
$t_{\text{PWV}}$	Verify pulse width		30	—	—	$\mu\text{s}$
$t_{\text{PWP}}$	Programming pulse width		20	—	—	ms

Figure 3. Erase (User Erase or Erase All) Timing Diagram

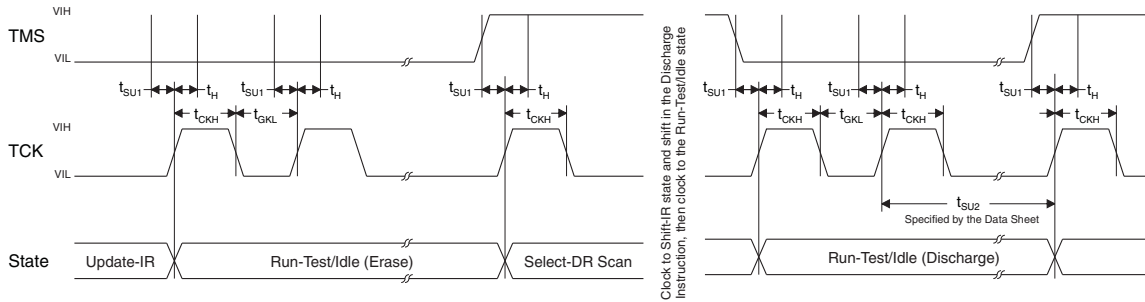

Figure 4. Programming Timing Diagram

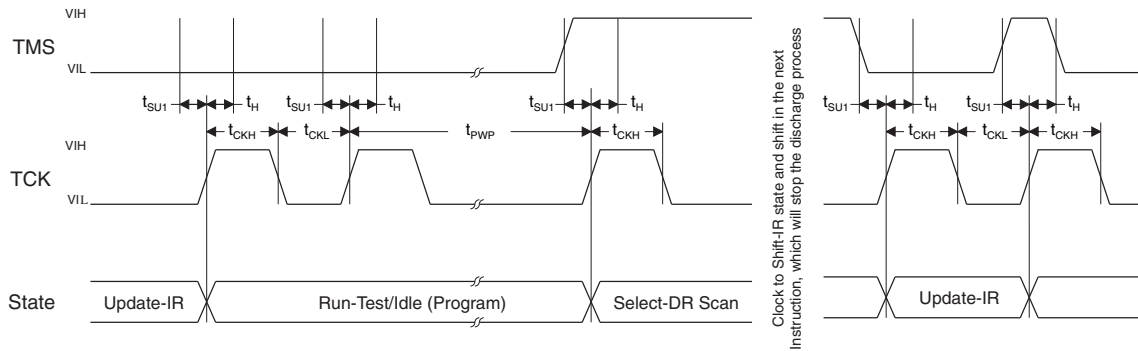

Figure 5. Verify Timing Diagram

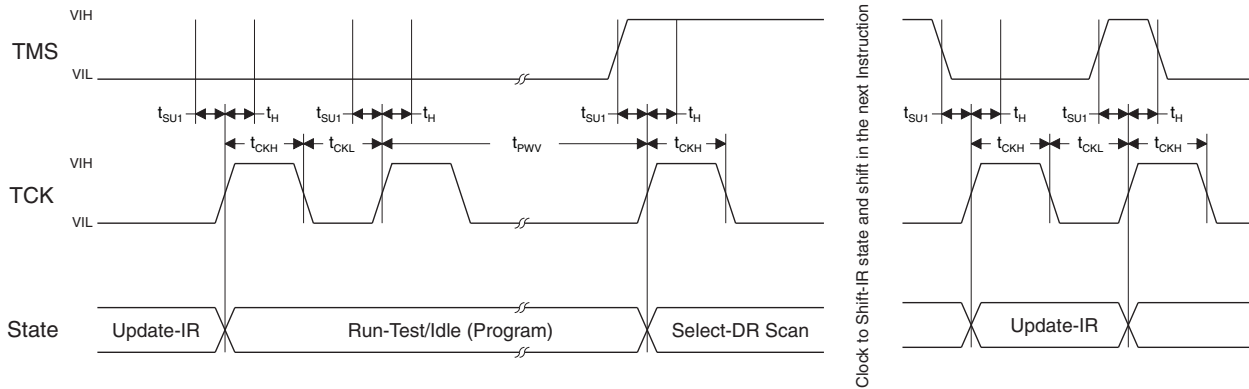
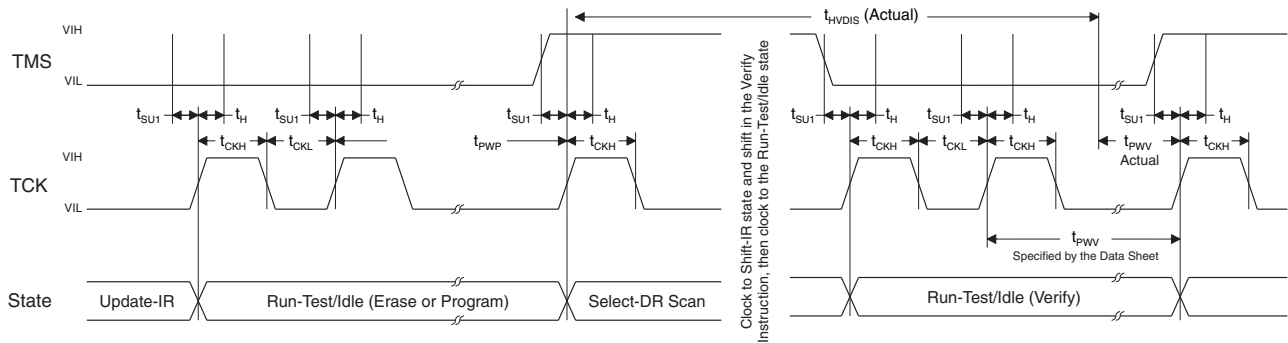

Figure 6. Discharge Timing Diagram



## Theory of Operation

### Analog Monitor Inputs

The ispPAC-POWR1014/A provides 10 independently programmable voltage monitor input circuits as shown in Figure 7. Two individually programmable trip-point comparators are connected to an analog monitoring input. Each comparator reference has 370 programmable trip points over the range of 0.672 V to 5.867 V. Additionally, a 75 mV 'zero-detect' threshold is selectable which allows the voltage monitors to determine if a monitored signal has dropped to ground level. This feature is especially useful for determining if a power supply's output has decayed to a substantially inactive condition after it has been switched off.

Figure 7. ispPAC-POWR1014/A Voltage Monitors

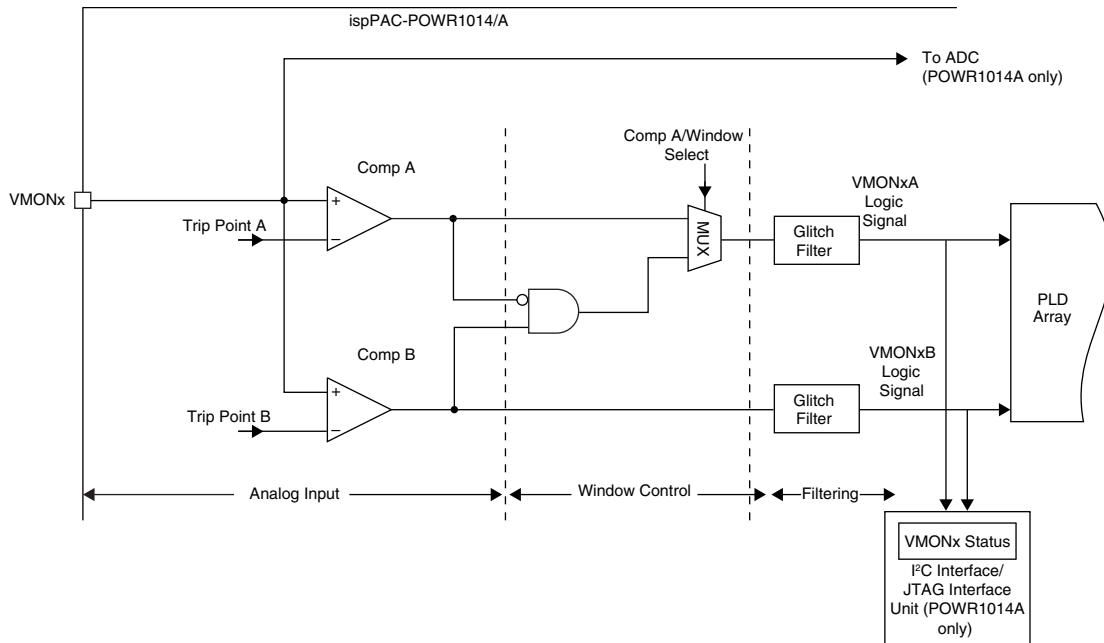

Figure 7 shows the functional block diagram of one of the 10 voltage monitor inputs - 'x' (where x = 1...10). Each voltage monitor can be divided into three sections: Analog Input, Window Control, and Filtering.

The voltage input is monitored by two individually programmable trip-point comparators, shown as CompA and CompB. Table 1 shows all trip points and the range to which any comparator's threshold can be set.

Each comparator outputs a HIGH signal to the PLD array if the voltage at its positive terminal is greater than its programmed trip point setting, otherwise it outputs a LOW signal.

A hysteresis of approximately 1% of the setpoint is provided by the comparators to reduce false triggering as a result of input noise. The hysteresis provided by the voltage monitor is a function of the input divider setting. Table 3 lists the typical hysteresis versus voltage monitor trip-point.

### AGOOD Logic Signal

All the VMON comparators auto-calibrate immediately after a power-on reset event. During this time, the digital glitch filters are also initialized. This process completion is signalled by an internally generated logic signal: AGOOD. All logic using the VMON comparator logic signals must wait for the AGOOD signal to become active.

### Programmable Over-Voltage and Under-Voltage Thresholds

Figure 8 (a) shows the power supply ramp-up and ramp-down voltage waveforms. Because of hysteresis, the comparator outputs change state at different thresholds depending on the direction of excursion of the monitored power supply.

**Figure 8. (a) Power Supply Voltage Ramp-up and Ramp-down Waveform and the Resulting Comparator Output, (b) Corresponding to Upper and Lower Trip Points**

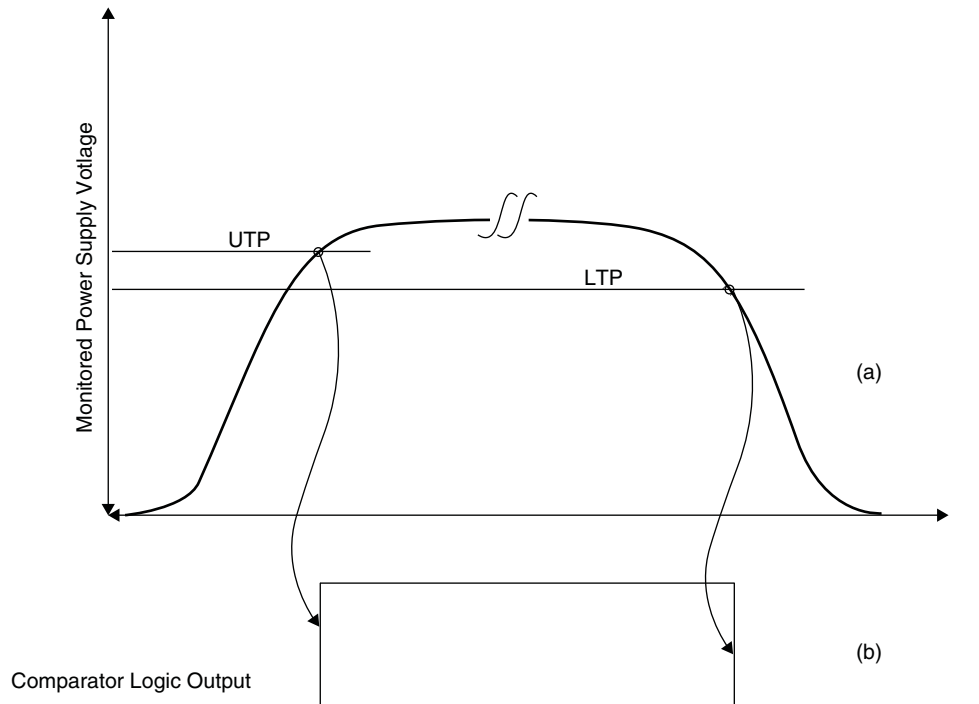

During power supply ramp-up the comparator output changes from logic 0 to 1 when the power supply voltage crosses the upper trip point (UTP). During ramp down the comparator output changes from logic state 1 to 0 when the power supply voltage crosses the lower trip point (LTP). To monitor for over-voltage fault conditions, the UTP should be used. To monitor under-voltage fault conditions, the LTP should be used.

Tables 1 and 2 show both the under-voltage and over-voltage trip points, which are automatically selected in software depending on whether the user is monitoring for an over-voltage condition or an under-voltage condition.

**Table 1. Trip Point Table Used For Over-Voltage Detection**

Coarse Range Setting												
Fine Range Setting	1	2	3	4	5	6	7	8	9	10	11	12
1	0.806	0.960	1.143	1.360	1.612	1.923	2.290	2.719	3.223	3.839	4.926	5.867
2	0.802	0.955	1.137	1.353	1.603	1.913	2.278	2.705	3.206	3.819	4.900	5.836
3	0.797	0.950	1.131	1.346	1.595	1.903	2.266	2.691	3.190	3.799	4.875	5.806
4	0.793	0.945	1.125	1.338	1.586	1.893	2.254	2.677	3.173	3.779	4.849	5.775
5	0.789	0.940	1.119	1.331	1.578	1.883	2.242	2.663	3.156	3.759	4.823	5.745
6	0.785	0.935	1.113	1.324	1.570	1.873	2.230	2.649	3.139	3.739	4.798	5.714
7	0.781	0.930	1.107	1.317	1.561	1.863	2.219	2.634	3.122	3.719	4.772	5.683
8	0.776	0.925	1.101	1.310	1.553	1.853	2.207	2.620	3.106	3.699	4.746	5.653
9	0.772	0.920	1.095	1.303	1.544	1.843	2.195	2.606	3.089	3.679	4.721	5.622
10	0.768	0.915	1.089	1.296	1.536	1.833	2.183	2.592	3.072	3.659	4.695	5.592
11	0.764	0.910	1.083	1.289	1.528	1.823	2.171	2.578	3.055	3.639	4.669	5.561
12	0.760	0.905	1.077	1.282	1.519	1.813	2.159	2.564	3.038	3.619	4.644	5.531
13	0.755	0.900	1.071	1.275	1.511	1.803	2.147	2.550	3.022	3.599	4.618	5.500
14	0.751	0.895	1.065	1.268	1.502	1.793	2.135	2.535	3.005	3.579	4.592	5.470
15	0.747	0.890	1.059	1.261	1.494	1.783	2.123	2.521	2.988	3.559	4.567	5.439
16	0.743	0.885	1.053	1.254	1.486	1.773	2.111	2.507	2.971	3.539	4.541	5.408
17	0.739	0.880	1.047	1.246	1.477	1.763	2.099	2.493	2.954	3.519	4.515	5.378
18	0.734	0.875	1.041	1.239	1.469	1.753	2.087	2.479	2.938	3.499	4.490	5.347
19	0.730	0.870	1.035	1.232	1.460	1.743	2.075	2.465	2.921	3.479	4.464	5.317
20	0.726	0.865	1.029	1.225	1.452	1.733	2.063	2.450	2.904	3.459	4.438	5.286
21	0.722	0.860	1.024	1.218	1.444	1.723	2.052	2.436	2.887	3.439	4.413	5.256
22	0.718	0.855	1.018	1.211	1.435	1.713	2.040	2.422	2.871	3.419	4.387	5.225
23	0.713	0.850	1.012	1.204	1.427	1.703	2.028	2.408	2.854	3.399	4.361	5.195
24	0.709	0.845	1.006	1.197	1.418	1.693	2.016	2.394	2.837	3.379	4.336	5.164
25	0.705	0.840	1.000	1.190	1.410	1.683	2.004	2.380	2.820	3.359	4.310	5.133
26	0.701	0.835	0.994	1.183	1.402	1.673	1.992	2.365	2.803	3.339	4.284	5.103
27	0.697	0.830	0.988	1.176	1.393	1.663	1.980	2.351	2.787	3.319	4.259	5.072
28	0.692	0.825	0.982	1.169	1.385	1.653	1.968	2.337	2.770	3.299	4.233	5.042
29	0.688	0.820	0.976	1.161	1.377	1.643	1.956	2.323	2.753	3.279	4.207	5.011
30	0.684	0.815	0.970	1.154	1.368	1.633	1.944	2.309	2.736	3.259	4.182	4.981
31	0.680	0.810	0.964	1.147	—	1.623	1.932	2.295	—	3.239	4.156	4.950
Low-V Sense	75 mV											

**Table 2. Trip Point Table Used For Under-Voltage Detection**

Fine Range Setting	1	2	3	4	5	6	7	8	9	10	11	12
1	0.797	0.950	1.131	1.346	1.595	1.903	2.266	2.691	3.190	3.799	4.875	5.806
2	0.793	0.945	1.125	1.338	1.586	1.893	2.254	2.677	3.173	3.779	4.849	5.775
3	0.789	0.940	1.119	1.331	1.578	1.883	2.242	2.663	3.156	3.759	4.823	5.745
4	0.785	0.935	1.113	1.324	1.570	1.873	2.230	2.649	3.139	3.739	4.798	5.714
5	0.781	0.930	1.107	1.317	1.561	1.863	2.219	2.634	3.122	3.719	4.772	5.683
6	0.776	0.925	1.101	1.310	1.553	1.853	2.207	2.620	3.106	3.699	4.746	5.653
7	0.772	0.920	1.095	1.303	1.544	1.843	2.195	2.606	3.089	3.679	4.721	5.622
8	0.768	0.915	1.089	1.296	1.536	1.833	2.183	2.592	3.072	3.659	4.695	5.592
9	0.764	0.910	1.083	1.289	1.528	1.823	2.171	2.578	3.055	3.639	4.669	5.561
10	0.760	0.905	1.077	1.282	1.519	1.813	2.159	2.564	3.038	3.619	4.644	5.531
11	0.755	0.900	1.071	1.275	1.511	1.803	2.147	2.550	3.022	3.599	4.618	5.500
12	0.751	0.895	1.065	1.268	1.502	1.793	2.135	2.535	3.005	3.579	4.592	5.470
13	0.747	0.890	1.059	1.261	1.494	1.783	2.123	2.521	2.988	3.559	4.567	5.439
14	0.743	0.885	1.053	1.254	1.486	1.773	2.111	2.507	2.971	3.539	4.541	5.408
15	0.739	0.880	1.047	1.246	1.477	1.763	2.099	2.493	2.954	3.519	4.515	5.378
16	0.734	0.875	1.041	1.239	1.469	1.753	2.087	2.479	2.938	3.499	4.490	5.347
17	0.730	0.870	1.035	1.232	1.460	1.743	2.075	2.465	2.921	3.479	4.464	5.317
18	0.726	0.865	1.029	1.225	1.452	1.733	2.063	2.450	2.904	3.459	4.438	5.286
19	0.722	0.860	1.024	1.218	1.444	1.723	2.052	2.436	2.887	3.439	4.413	5.256
20	0.718	0.855	1.018	1.211	1.435	1.713	2.040	2.422	2.871	3.419	4.387	5.225
21	0.713	0.850	1.012	1.204	1.427	1.703	2.028	2.408	2.854	3.399	4.361	5.195
22	0.709	0.845	1.006	1.197	1.418	1.693	2.016	2.394	2.837	3.379	4.336	5.164
23	0.705	0.840	1.000	1.190	1.410	1.683	2.004	2.380	2.820	3.359	4.310	5.133
24	0.701	0.835	0.994	1.183	1.402	1.673	1.992	2.365	2.803	3.339	4.284	5.103
25	0.697	0.830	0.988	1.176	1.393	1.663	1.980	2.351	2.787	3.319	4.259	5.072
26	0.692	0.825	0.982	1.169	1.385	1.653	1.968	2.337	2.770	3.299	4.233	5.042
27	0.688	0.820	0.976	1.161	1.377	1.643	1.956	2.323	2.753	3.279	4.207	5.011
28	0.684	0.815	0.970	1.154	1.368	1.633	1.944	2.309	2.736	3.259	4.182	4.981
29	0.680	0.810	0.964	1.147	1.360	1.623	1.932	2.295	2.719	3.239	4.156	4.950
30	0.676	0.805	0.958	1.140	1.352	1.613	1.920	2.281	2.702	3.219	4.130	4.919
31	0.672	0.800	0.952	1.133	—	1.603	1.908	2.267	—	3.199	4.105	4.889
Low-V Sense	75 mV											

**Table 3. Comparator Hysteresis vs. Trip-Point**

Trip-point Range (V)		Hysteresis (mV)
Low Limit	High Limit	
0.672	0.806	8
0.800	0.960	10
0.952	1.143	12
1.133	1.360	14
1.346	1.612	17
1.603	1.923	20
1.908	2.290	24
2.267	2.719	28
2.691	3.223	34
3.199	3.839	40
4.105	4.926	51
4.889	5.867	61
75 mV		0 (Disabled)

The window control section of the voltage monitor circuit is an AND gate (with inputs: an inverted COMPA “ANDed” with COMPB signal) and a multiplexer that supports the ability to develop a ‘window’ function without using any of the PLD’s resources. Through the use of the multiplexer, voltage monitor’s ‘A’ output may be set to report either the status of the ‘A’ comparator, or the window function of both comparator outputs. The voltage monitor’s ‘A’ output indicates whether the input signal is between or outside the two comparator thresholds. **Important:** This windowing function is only valid in cases where the threshold of the ‘A’ comparator is set to a value higher than that of the ‘B’ comparator. Table 4 shows the operation of window function logic.

**Table 4. Voltage Monitor Windowing Logic**

Input Voltage	Comp A	Comp B	Window (B and Not A)	Comment
$V_{IN} < \text{Trip-point B} < \text{Trip-point A}$	0	0	0	Outside window, low
$\text{Trip-point B} < V_{IN} < \text{Trip-point A}$	0	1	1	Inside window
$\text{Trip-point B} < \text{Trip-point A} < V_{IN}$	1	1	0	Outside window, high

Note that when the ‘A’ output of the voltage monitor circuit is set to windowing mode, the ‘B’ output continues to monitor the output of the ‘B’ comparator. This can be useful in that the ‘B’ output can be used to augment the windowing function by determining if the input is above or below the windowing range.

The third section in the ispPAC-POWR1014/A’s input voltage monitor is a digital filter. When enabled, the comparator output will be delayed by a filter time constant of 64  $\mu\text{s}$ , and is especially useful for reducing the possibility of false triggering from noise that may be present on the voltages being monitored. When the filter is disabled, the comparator output will be delayed by 16 $\mu\text{s}$ . In both cases, enabled or disabled, the filters also provide synchronization of the input signals to the PLD clock. This synchronous sampling feature effectively eliminates the possibility of race conditions from occurring in any subsequent logic that is implemented in the ispPAC-POWR1014/A’s internal PLD logic.

The comparator status can be read from the I<sup>2</sup>C interface or JTAG interface (ispPAC-POWR1014A only). For details on the I<sup>2</sup>C/JTAG interfaces, please refer to the I<sup>2</sup>C/SMBUS Interface, and Accessing I<sup>2</sup>C Registers Through JTAG sections of this data sheet.

## VMON Voltage Measurement with the On-chip Analog to Digital Converter (ADC, ispPAC-POWR1014A Only)

The ispPAC-POWR1014A has an on-chip analog to digital converter that can be used for measuring the voltages at the VMON inputs.

**Figure 9. ADC Monitoring VMON1 to VMON10**

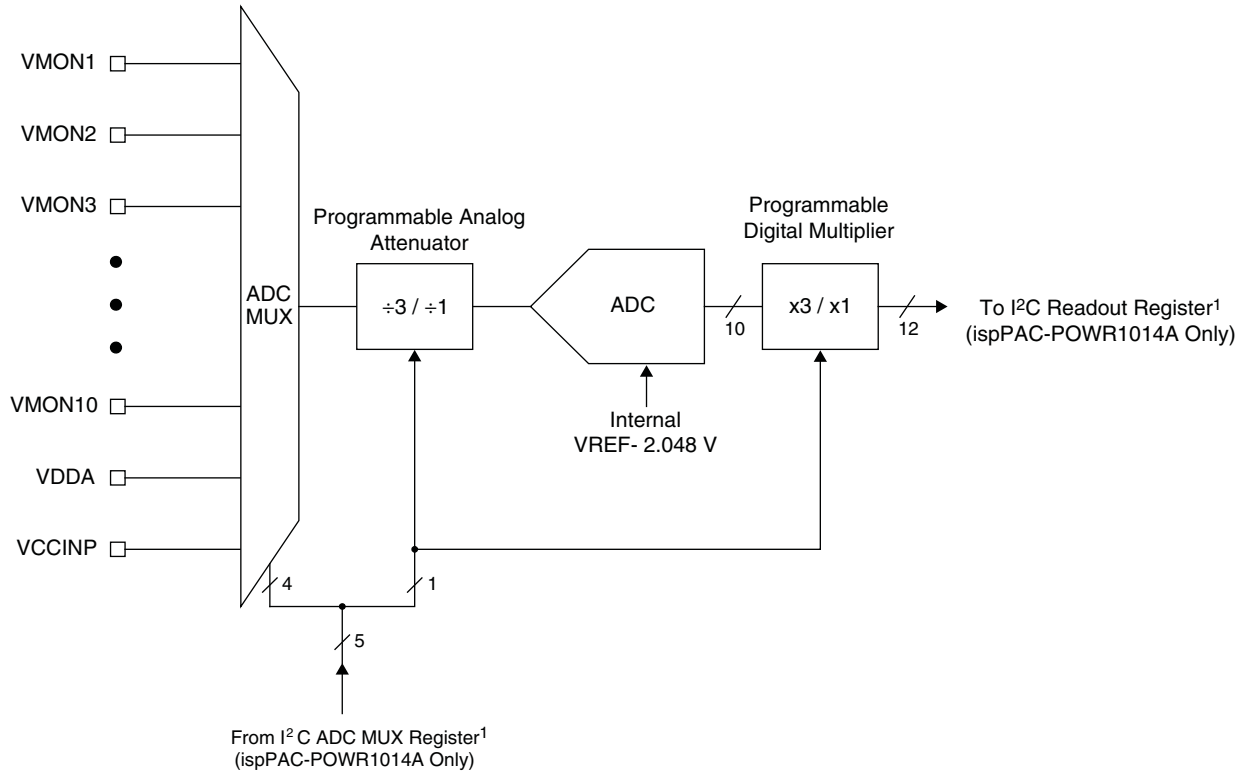

1. Can be accessed through JTAG port.

Figure 9 shows the ADC circuit arrangement within the ispPAC-POWR1014A device. The ADC can measure all analog input voltages through the multiplexer, ADC MUX. The programmable attenuator between the ADC mux and the ADC can be configured as divided-by-3 or divided-by-1 (no attenuation). The divided-by-3 setting is used to measure voltages from 0 V to 6 V range and divided-by-1 setting is used to measure the voltages from 0 V to 2 V range.

A microcontroller can place a request for any VMON voltage measurement at any time through the I<sup>2</sup>C/JTAG port (ispPAC-POWR1014A only). Upon the receipt of an ADCMUX selection command, the ADC will be connected to the selected VMON through the ADC MUX. The ADC output is then latched into the I<sup>2</sup>C readout registers. The contents of the ADC interface register can be read out from the I<sup>2</sup>C or JTAG port.

### Calculation

The algorithm to convert the ADC code to the corresponding voltage takes into consideration the attenuation bit value. In other words, if the attenuation bit is set, then the 10-bit ADC result is automatically multiplied by 3 to calculate the actual voltage at that VMON input. Thus, the I<sup>2</sup>C readout register is 12 bits instead of 10 bits. The following formula can always be used to calculate the actual voltage from the ADC code.

### Voltage at the VMONx Pins

$$\text{VMON} = \text{I}^2\text{C Readout Register (12 bits}^2, \text{ converted to decimal)} * 2 \text{ mV}$$

<sup>2</sup>Note: ADC\_VALUE\_HIGH (8 bits), ADC\_VALUE\_LOW (4 bits) read from I<sup>2</sup>C/JTAG port (ispPAC-POWR1014A only).

### PLD Block

Figure 10 shows the ispPAC-POWR1014/A PLD architecture, which is derived from the Lattice ispMACH® 4000 CPLD. The PLD architecture allows the flexibility in designing various state machines and control functions used for power supply management. The AND array has 53 inputs and generates 123 product terms. These 123 product terms are divided into three groups of 41 for each of the generic logic blocks, GLB1, GLB2, and GLB3. Each GLB is made up of eight macrocells. In total, there are 24 macrocells in the ispPAC-POWR1014/A device. The output signals of the ispPAC-POWR1014/A device are derived from GLBs as shown in Figure 10. GLB3 generates timer control.

Figure 10. ispPAC-POWR1014/A PLD Architecture

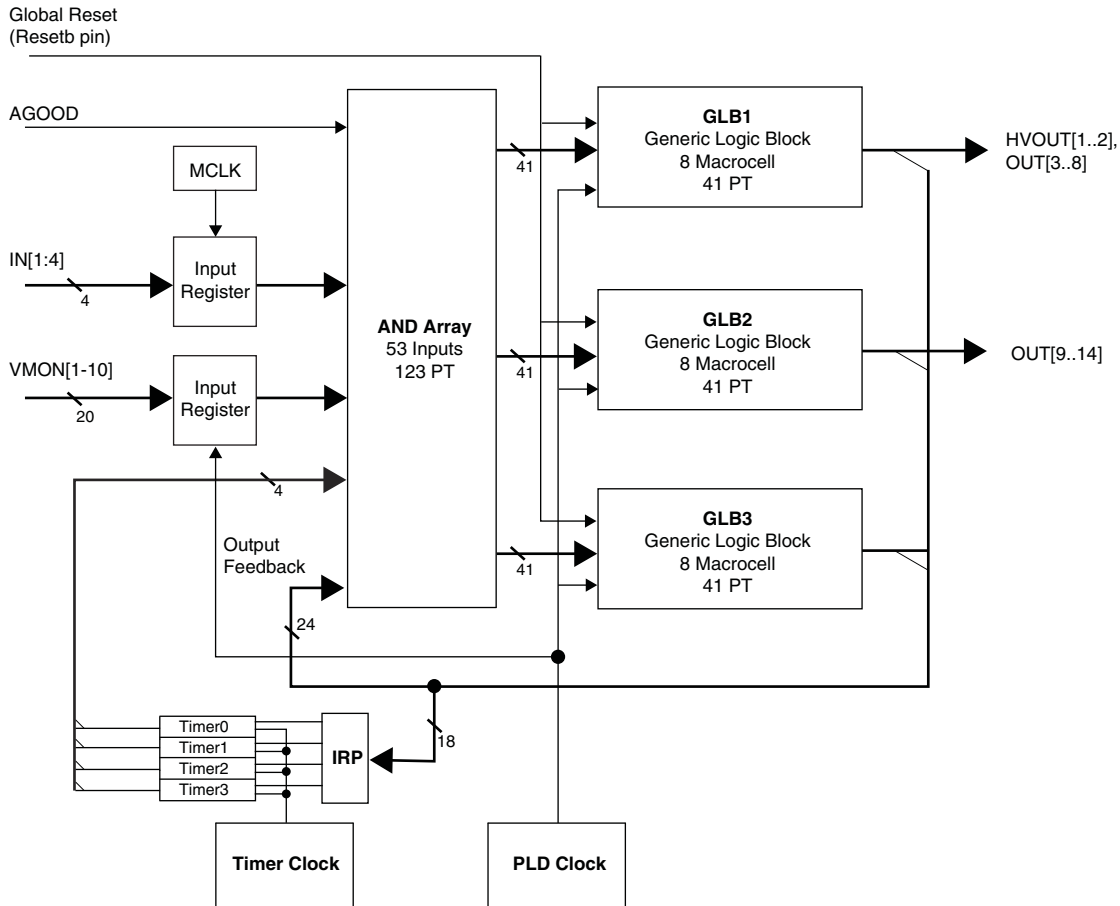

### Macrocell Architecture

The macrocell shown in Figure 11 is the heart of the PLD. The basic macrocell has five product terms that feed the OR gate and the flip-flop. The flip-flop in each macrocell is independently configured. It can be programmed to function as a D-Type or T-Type flip-flop. Combinatorial functions are realized by bypassing the flip-flop. The polarity control and XOR gates provide additional flexibility for logic synthesis. The flip-flop's clock is driven from the common PLD clock that is generated by dividing the 8 MHz master clock by 32. The macrocell also supports asynchronous reset and preset functions, derived from either product terms, the global reset input, or the power-on reset signal. The resources within the macrocells share routing and contain a product term allocation array. The product term allocation array greatly expands the PLD's ability to implement complex logical functions by allowing logic to be shared between adjacent blocks and distributing the product terms to allow for wider decode functions. All the digital inputs are registered by MCLK and the VMON comparator outputs are registered by the PLD Clock to synchronize them to the PLD logic.

Figure 11. ispPAC-POWR1014/A Macrocell Block Diagram

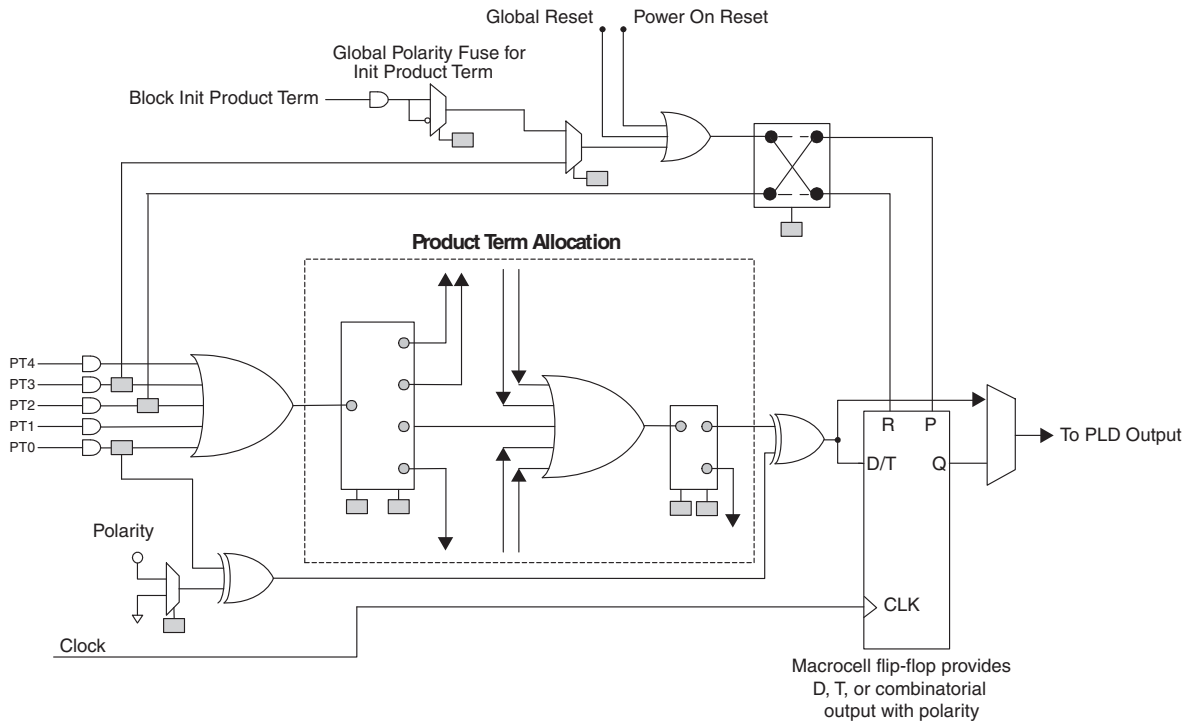

### Clock and Timer Functions

Figure 12 shows a block diagram of the ispPAC-POWR1014/A's internal clock and timer systems. The master clock operates at a fixed frequency of 8MHz, from which a fixed 250kHz PLD clock is derived.

Figure 12. Clock and Timer System

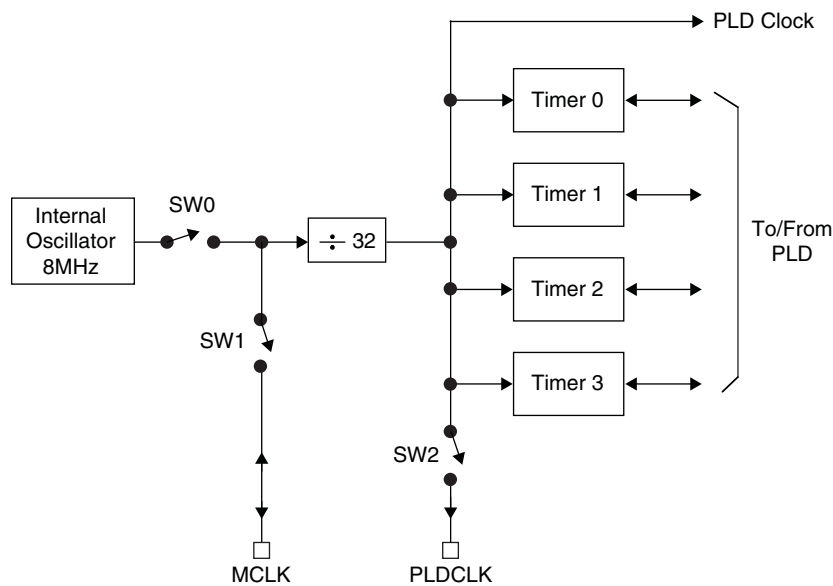

The internal oscillator runs at a fixed frequency of 8 MHz. This signal is used as a source for the PLD and timer clocks. It is also used for clocking the comparator outputs and clocking the digital filters in the voltage monitor circuits and ADC. The ispPAC-POWR1014/A can be programmed to operate in three modes: Master mode, Stand-

alone mode and Slave mode. Table 5 summarizes the operating modes of ispPAC-POWR1014/A.

**Table 5. ispPAC-POWR1014/A Operating Modes**

Timer Operating Mode	SW0	SW1	Condition	Comments
Standalone	Closed	Open	When only one ispPAC-POWR1014/A is used.	MCLK pin tristated
Master	Closed	Closed	When more than one ispPAC-POWR1014/A is used on a board, one of them should be configured to operate in this mode.	MCLK pin outputs 8MHz clock
Slave	Open	Closed	When more than one ispPAC-POWR1014/As is used on a board. Other than the master, the rest of the ispPAC-POWR1014/As should be programmed as slaves.	MCLK pin is input

A divide-by-32 prescaler divides the internal 8 MHz oscillator (or external clock, if selected) down to 250kHz for the PLD clock and for the programmable timers. This PLD clock may be made available on the PLDCLK pin by closing SW2. Each of the four timers provides independent timeout intervals ranging from 32  $\mu$ s to 1.96 seconds in 128 steps.

### Digital Outputs

The ispPAC-POWR1014/A provides 14 digital outputs, HVOUT[1:2] and OUT[3:14]. Outputs OUT[3:14] are permanently configured as open drain to provide a high degree of flexibility when interfacing to logic signals, LEDs, opto-couplers, and power supply control inputs. The HVOUT[1:2] pins can be configured as either high voltage FET drivers or open drain outputs. Each of these outputs may be controlled either from the PLD or from the I<sup>2</sup>C register (ispPAC-POWR1014A only). The determination whether a given output is under PLD or I<sup>2</sup>C control may be made on a pin-by-pin basis (see Figure 13). For further details on controlling the outputs through I<sup>2</sup>C, please see the I<sup>2</sup>C/SMBUS Interface and Accessing I<sup>2</sup>C Registers Through JTAG sections of this data sheet.

**Figure 13. Digital Output Pin Configuration**

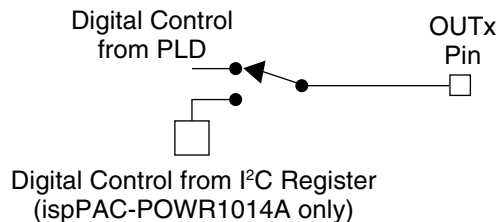

### High-Voltage Outputs

In addition to being usable as digital open-drain outputs, the ispPAC-POWR1014/A's HVOUT1-HVOUT2 output pins can be programmed to operate as high-voltage FET drivers. Figure 14 shows the details of the HVOUT gate drivers. Each of these outputs may be controlled from the PLD, or with the ispPAC-POWR1014A, from the I<sup>2</sup>C registers (see Figure 14). For further details on controlling the outputs through I<sup>2</sup>C, please see the I<sup>2</sup>C/SMBUS Interface, and Accessing I<sup>2</sup>C Registers Through JTAG sections of this data sheet.

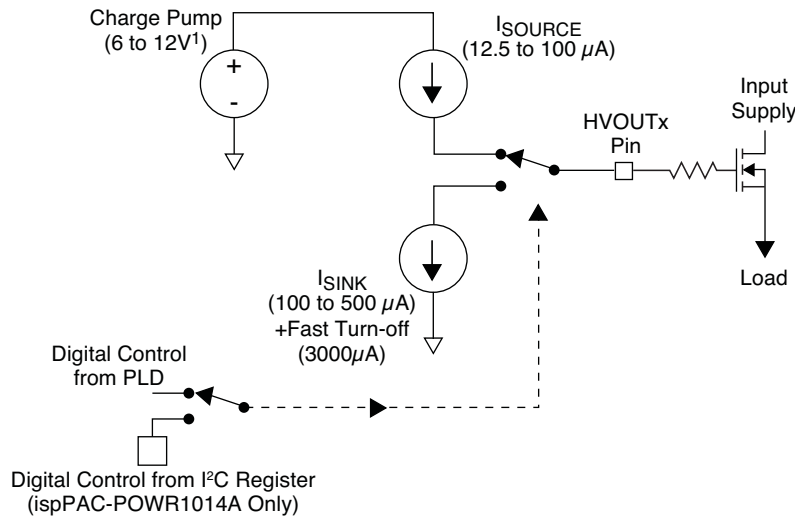
**Figure 14. Basic Function Diagram for an Output in High Voltage MOSFET Gate Driver Mode**

1. -01 performance grade devices provide three selectable output voltage settings from 6 V to 10 V in 2 V steps. The -02 performance grade devices also support the 12 V output voltage setting.

Figure 14 shows the HVOUT circuitry when programmed as a FET driver. In this mode the output either sources current from a charge pump or sinks current. The maximum voltage that the output level at the pin will rise to is also programmable between 6 V and 12 V<sup>1</sup>. The maximum voltage levels that are required depend on the gate-to-source threshold of the FET being driven and the power supply voltage being switched. The maximum voltage level needs to be sufficient to bias the gate-to-source threshold on and also accommodate the load voltage at the FET's source, since the source pin of the FET to provide a wide range of ramp rates is tied to the supply of the target board. When the HVOUT pin is sourcing current, charging a FET gate, the source current is programmable between 12.5 µA and 100 µA. When the driver is turned to the off state, the driver will sink current to ground, and this sink current is also programmable between 3000 µA and 100 µA to control the turn-off rate.

### Programmable Output Voltage Levels for HVOUT1- HVOUT2

There are four<sup>1</sup> selectable steps for the output voltage of the FET drivers when in FET driver mode. The voltage that the pin is capable of driving to can be programmed from 6 V to 12 V<sup>1</sup> in 2 V steps.

1. -01 performance grade devices provide three selectable output voltage settings from 6 V to 10 V in 2 V steps. The -02 performance grade devices also support the 12 V output voltage setting.

### RESETb Signal, RESET Command via JTAG or I²C

Activating the RESETb signal (Logic 0 applied to the RESETb pin) or issuing a reset instruction via JTAG, or with the ispPAC-POWR1014A, I²C will force the outputs to the following states independent of how these outputs have been configured in the PINS window:

- OUT3-14 will go high-impedance.
- HVOUT pins programmed for open drain operation will go high-impedance.
- HVOUT pins programmed for FET driver mode operation will pull down.

At the conclusion of the RESET event, these outputs will go to the states defined by the PINS window, and if a sequence has been programmed into the device, it will be restarted at the first step. The analog calibration will be redone and consequently, the VMONs, and ADCs will not be operational until 500 microseconds (max.) after the conclusion of the RESET event.

**CAUTION:** Activating the RESETb signal or issuing a RESET command through I2C or JTAG during the ispPAC-POWR1014/A device operation, results in the device aborting all operations and returning to the power-on reset state. The status of the power supplies which are being enabled by the ispPAC-POWR1014/A will be determined by the state of the outputs shown above.

### I<sup>2</sup>C/SMBUS Interface (ispPAC-POWR1014A Only)

I<sup>2</sup>C and SMBus are low-speed serial interface protocols designed to enable communications among a number of devices on a circuit board. The ispPAC-POWR1014A supports a 7-bit addressing of the I<sup>2</sup>C communications protocol, as well as SMBTimeout and SMBAlert features of the SMBus, enabling it to easily integrated into many types of modern power management systems. Figure 15 shows a typical I<sup>2</sup>C configuration, in which one or more ispPAC-POWR1014As are slaved to a supervisory microcontroller. SDA is used to carry data signals, while SCL provides a synchronous clock signal. The SMBAlert line is only present in SMBus systems. The 7-bit I<sup>2</sup>C address of the POWR1014A is fully programmable through the JTAG port.

**Figure 15. ispPAC-POWR1014A in I<sup>2</sup>C/SMBUS System**

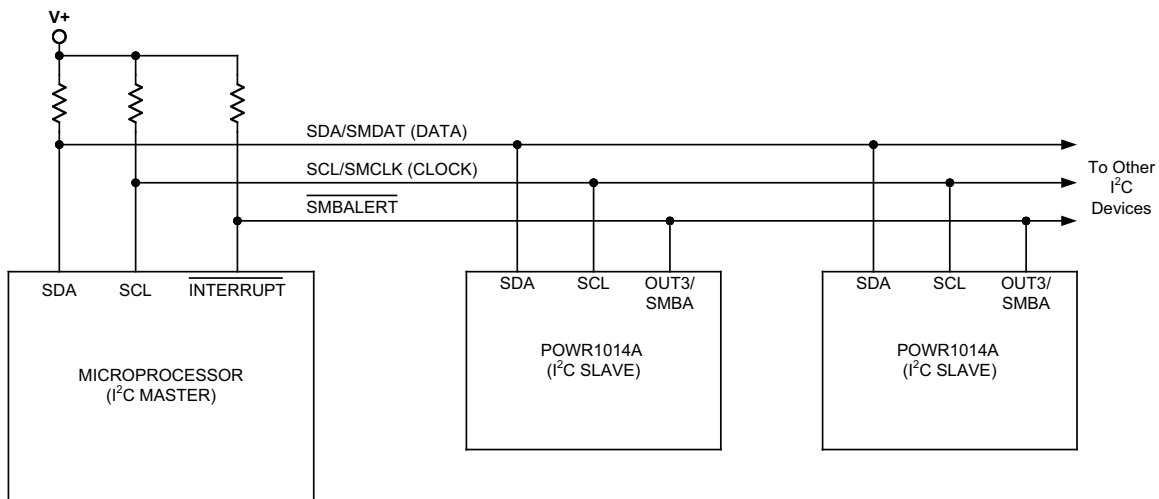

In both the I<sup>2</sup>C and SMBus protocols, the bus is controlled by a single MASTER device at any given time. This master device generates the SCL clock signal and coordinates all data transfers to and from a number of slave devices. The ispPAC-POWR1014A is configured as a slave device, and cannot independently coordinate data transfers. Each slave device on a given I<sup>2</sup>C bus is assigned a unique address. The ispPAC-POWR1014A implements the 7-bit addressing portion of the standard. Any 7-bit address can be assigned to the ispPAC-POWR1014A device by programming through JTAG. When selecting a device address, one should note that several addresses are reserved by the I<sup>2</sup>C and/or SMBus standards, and should not be assigned to ispPAC-POWR1014A devices to assure bus compatibility. Table 6 lists these reserved addresses.

**Table 6. I<sup>2</sup>C/SMBus Reserved Slave Device Addresses**

Address	R/W bit	I <sup>2</sup> C function Description	SMBus Function
0000 000	0	General Call Address	General Call Address
0000 000	1	Start Byte	Start Byte
0000 001	x	CBUS Address	CBUS Address
0000 010	x	Reserved	Reserved
0000 011	x	Reserved	Reserved
0000 1xx	x	HS-mode master code	HS-mode master code
0001 000	x	NA	SMBus Host
0001 100	x	NA	SMBus Alert Response Address
0101 000	x	NA	Reserved for ACCESS.bus
0110 111	x	NA	Reserved for ACCESS.bus
1100 001	x	NA	SMBus Device Default Address
1111 0xx	x	10-bit addressing	10-bit addressing
1111 1xx	x	Reserved	Reserved

The ispPAC-POWR1014A’s I<sup>2</sup>C/SMBus interface allows data to be both written to and read from the device. A data write transaction (Figure 16) consists of the following operations:

1. Start the bus transaction
2. Transmit the device address (7 bits) along with a low write bit
3. Transmit the address of the register to be written to (8 bits)
4. Transmit the data to be written (8 bits)
5. Stop the bus transaction

To start the transaction, the master device holds the SCL line high while pulling SDA low. Address and data bits are then transferred on each successive SCL pulse, in three consecutive byte frames of 9 SCL pulses. Address and data are transferred on the first 8 SCL clocks in each frame, while an acknowledge signal is asserted by the slave device on the 9th clock in each frame. Both data and addresses are transferred in a most-significant-bit-first format. The first frame contains the 7-bit device address, with bit 8 held low to indicate a write operation. The second frame contains the register address to which data will be written, and the final frame contains the actual data to be written. Note that the SDA signal is only allowed to change when the SCL is low, as raising SDA when SCL is high signals the end of the transaction.

**Figure 16. I<sup>2</sup>C Write Operation**

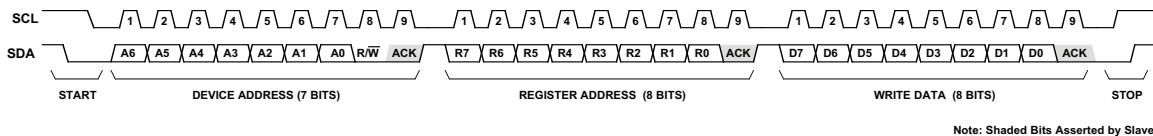

Reading a data byte from the ispPAC-POWR1014A requires two separate bus transactions (Figure 17). The first transaction writes the register address from which a data byte is to be read. Note that since no data is being written to the device, the transaction is concluded after the second byte frame. The second transaction performs the actual read. The first frame contains the 7-bit device address with the R/W bit held High. In the second frame the ispPAC-POWR1014A asserts data out on the bus in response to the SCL signal. Note that the acknowledge signal in the second frame is asserted by the master device and not the ispPAC-POWR1014A.

**Figure 17. I<sup>2</sup>C Read Operation**

**STEP 1: WRITE REGISTER ADDRESS FOR READ OPERATION**

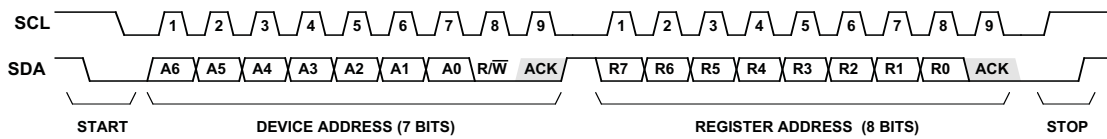

**STEP 2: READ DATA FROM THAT REGISTER**

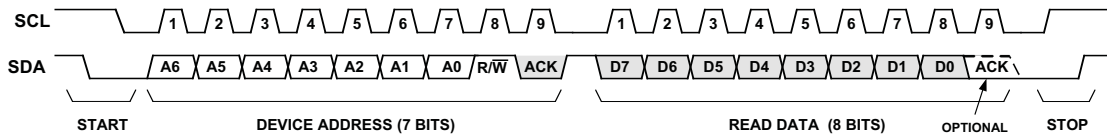

Note: Shaded Bits Asserted by Slave

The ispPAC-POWR1014A provides 17 registers that can be accessed through its I<sup>2</sup>C interface. These registers provide the user with the ability to monitor and control the device's inputs and outputs, and transfer data to and from the device. Table 7 provides a summary of these registers.

**Table 7. I<sup>2</sup>C Control Registers<sup>1</sup>**

Register Address	Register Name	Read/Write	Description	Value After POR <sup>2,3</sup>
0x00	vmon_status0	R	VMON input status Vmon[4:1]	---- ----
0x01	vmon_status1	R	VMON input status Vmon[8:5]	---- ----
0x02	vmon_status2	R	VMON input status Vmon[10:9]	X X X X ----
0x03	output_status0	R	Output status OUT[8:3], HVOUT[2:1]	---- ----
0x04	output_status1	R	Output status OUT[14:9]	X X -- ----
0x06	input_status	R	Input status IN[4:1]	X X X X ----
0x07	adc_value_low	R	ADC D[3:0] and status	---- X X X 1
0x08	adc_value_high	R	ADC D[9:4]	---- ----
0x09	adc_mux	R/W	ADC Attenuator and MUX[3:0]	X X X 1 1 1 1 1
0x0A	UES_byte0	R	UES[7:0]	---- ----
0x0B	UES_byte1	R	UES[15:8]	---- ----
0x0C	UES_byte2	R	UES[23:16]	---- ----
0x0D	UES_byte3	R	UES[31:24]	---- ----
0x0E	gp_output1	R/W	GPOUT[8:1]	0 0 0 0 0 1 0 0
0x0F	gp_output2	R/W	GPOUT[14:9]	X X 0 0 0 0 0 0
0x11	input_value	R/W	PLD Input Register [4:2]	X X X X 0 0 0 X
0x12	reset	W	Resets device on write	N/A

1. These registers can also be accessed through the JTAG interface.
2. "X" = Non-functional bit (bits read out as 1's).
3. "-" = State depends on device configuration or input status.

Several registers are provided for monitoring the status of the analog inputs. The three registers VMON\_STATUS[0:2] provide the ability to read the status of the VMON output comparators. The ability to read both the 'a' and 'b' comparators from each VMON input is provided through the VMON input registers. Note that if a VMON input is configured to window comparison mode, then the corresponding VMONxA register bit will reflect the status of the window comparison.

**Figure 18. VMON Status Registers**
**0x00 - VMON\_STATUS0 (Read Only)**

VMON4B	VMON4A	VMON3B	VMON3A	VMON2B	VMON2A	VMON1B	VMON1A
b7	b6	b5	b4	b3	b2	b1	b0

**0x01 - VMON\_STATUS1 (Read Only)**

VMON8B	VMON8A	VMON7B	VMON7A	VMON6B	VMON6A	VMON5B	VMON5A
b7	b6	b5	b4	b3	b2	b1	b0

**0x02 - VMON\_STATUS2 (Read Only)**

1	1	1	1	VMON10B	VMON10A	VMON9B	VMON9A
b7	b6	b5	b4	b3	b2	b1	b0

It is also possible to directly read the value of the voltage present on any of the VMON inputs by using the ispPAC-POWR1014A's ADC. Three registers provide the I<sup>2</sup>C interface to the ADC (Figure 19).

**Figure 19. ADC Interface Registers**
**0x07 - ADC\_VALUE\_LOW (Read Only)**

D3	D2	D1	D0	1	1	1	DONE
b7	b6	b5	b4	b3	b2	b1	b0

**0x08 - ADC\_VALUE\_HIGH (Read Only)**

D11	D10	D9	D8	D7	D6	D5	D4
b7	b6	b5	b4	b3	b2	b1	b0

**0x09 - ADC\_MUX (Read/Write)**

X	X	X	ATTEN	SEL3	SEL2	SEL1	SEL0
b7	b6	b5	b4	b3	b2	b1	b0

To perform an A/D conversion, one must set the input attenuator and channel selector. Two input ranges may be set using the attenuator, 0 - 2.048 V and 0 - 6.144 V. Table 8 shows the input attenuator settings.

**Table 8. ADC Input Attenuator Control**

ATTEN (ADC_MUX.4)	Resolution	Full-Scale Range
0	2 mV	2.048 V
1	6 mV	6.144 V

The input selector may be set to monitor any one of the ten VMON inputs, the VCCA input, or the VCCINP input. Table 9 shows the codes associated with each input selection.

**Table 9. V<sub>MON</sub> Address Selection Table**

Select Word				Input Channel
SEL3 (ADC_MUX.3)	SEL2 (ADC_MUX.2)	SEL1 (ADC_MUX.1)	SEL0 (ADC_MUX.0)	
0	0	0	0	VMON1
0	0	0	1	VMON2
0	0	1	0	VMON3
0	0	1	1	VMON4
0	1	0	0	VMON5
0	1	0	1	VMON6
0	1	1	0	VMON7
0	1	1	1	VMON8
1	0	0	0	VMON9
1	0	0	1	VMON10
1	1	0	0	VCCA
1	1	0	1	VCCINP

Writing a value to the ADC\_MUX register to set the input attenuator and selector will automatically initiate a conversion. When the conversion is in process, the DONE bit (ADC\_VALUE\_LOW.0) will be reset to '0'. When the conversion is complete, this bit will be set to '1'. When the conversion is complete, the result may be read out of the ADC by performing two I<sup>2</sup>C read operations; one for ADC\_VALUE\_LOW, and one for ADC\_VALUE\_HIGH. It is recommended that the I<sup>2</sup>C master load a second conversion command only after the completion of the current conversion

command (Waiting for the DONE bit to be set to '1'). An alternative would be to wait for a minimum specified time (see  $T_{CONVERT}$  value in the specifications) and disregard checking the DONE bit.

Note that if the I<sup>2</sup>C clock rate falls below 50kHz (see  $F_{I2C}$  note in specifications), the only way to insure a valid ADC conversion is to wait the minimum specified time ( $T_{CONVERT}$ ), as the operation of the DONE bit at clock rates lower than that cannot be guaranteed. In other words, if the I<sup>2</sup>C clock rate is less than 50kHz, the DONE bit may or may not assert even though a valid conversion result is available.

To insure every ADC conversion result is valid, preferred operation is to clock I<sup>2</sup>C at more than 50kHz and verify DONE bit status or wait for the full  $T_{CONVERT}$  time period between subsequent ADC convert commands. If an I<sup>2</sup>C request is placed before the current conversion is complete, the DONE bit will be set to 1 only after the second request is complete.

The status of the digital input lines may also be monitored and controlled through I<sup>2</sup>C commands. Figure 20 shows the I<sup>2</sup>C interface to the IN[1:4] digital input lines. The input status may be monitored by reading the INPUT\_STATUS register, while input values to the PLD array may be set by writing to the INPUT\_VALUE register. To be able to set an input value for the PLD array, the input multiplexer associated with that bit needs to be set to the I<sup>2</sup>C register setting in E<sup>2</sup>CMOS memory otherwise the PLD will receive its input from the INx pin.

**Figure 20. I<sup>2</sup>C Digital Input Interface**

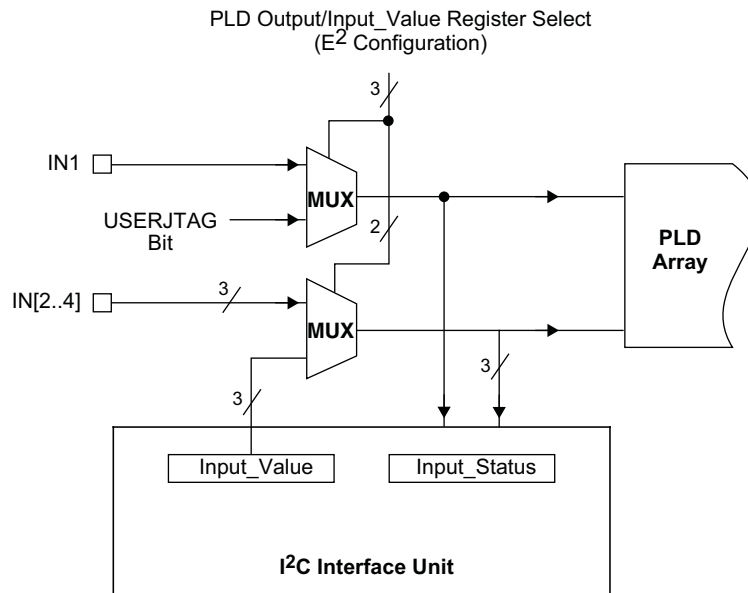

**0x06 - INPUT\_STATUS (Read Only)**

1	1	1	1	IN4	IN3	IN2	IN1
b7	b6	b5	b4	b3	b2	b1	b0

**0x11 - INPUT\_VALUE (Read/Write)**

X	X	X	X	I4	I3	I2	X
b7	b6	b5	b4	b3	b2	b1	b0

The digital outputs may also be monitored and controlled through the I<sup>2</sup>C interface, as shown in Figure 21. The status of any given digital output may be read by reading the contents of the associated OUTPUT\_STATUS[1:0] register. Note that in the case of the outputs, the status reflected by these registers reflects the logic signal used to drive the pin, and does not sample the actual level present on the output pin. For example, if an output is set high but is

not pulled up, the output status bit corresponding with that pin will read '1', but a high output signal will not appear on the pin.

Digital outputs may also be optionally controlled directly by the I<sup>2</sup>C bus instead of by the PLD array. The outputs may be driven either from the PLD output or from the contents of the GP\_OUTPUT[1:0] registers with the choice user-settable in E<sup>2</sup>CMOS memory. Each output may be independently set to output from the PLD or from the GP\_OUTPUT registers.

**Figure 21. I<sup>2</sup>C Output Monitor and Control Logic**

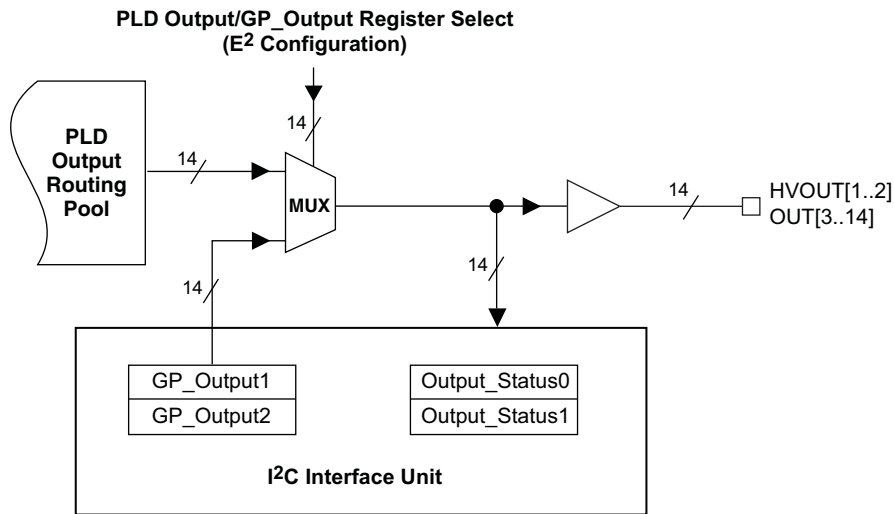

**0x03 - OUTPUT\_STATUS0 (Read Only)**

OUT8	OUT7	OUT6	OUT5	OUT4	OUT3	HVOUT2	HVOUT1
b7	b6	b5	b4	b3	b2	b1	b0

**0x04 - OUTPUT\_STATUS1 (Read Only)**

1	1	OUT14	OUT13	OUT12	OUT11	OUT10	OUT9
b7	b6	b5	b4	b3	b2	b1	b0

**0x0E - GP\_OUTPUT1 (Read/Write)**

GP8	GP7	GP6	GP5	GP4	GP3_ENb	GP2	GP1
b7	b6	b5	b4	b3	b2	b1	b0

**0x0F - GP\_OUTPUT2 (Read/Write)**

X	X	GP14	GP13	GP12	GP11	GP10	GP9
b7	b6	b5	b4	b3	b2	b1	b0

The UES word may also be read through the I<sup>2</sup>C interface, with the register mapping shown in Figure 22.

**Figure 22. I<sup>2</sup>C Register Mapping for UES Bits**
**0x0A - UES\_BYTE0 (Read Only)**

UES7	UES6	UES5	UES4	UES3	UES2	UES1	UES0
b7	b6	b5	b4	b3	b2	b1	b0

**0x0B - UES\_BYTE1 (Read Only)**

UES15	UES14	UES13	UES12	UES11	UES10	UES9	UES8
b7	b6	b5	b4	b3	b2	b1	b0

**0x0C - UES\_BYTE2 (Read Only)**

UES23	UES22	UES21	UES20	UES19	UES18	UES17	UES16
b7	b6	b5	b4	b3	b2	b1	b0

**0x0D - UES\_BYTE3 (Read Only)**

UES31	UES30	UES29	UES28	UES27	UES26	UES25	UES24
b7	b6	b5	b4	b3	b2	b1	b0

The I<sup>2</sup>C interface also provides the ability to initiate reset operations. The ispPAC-POWR1014A may be reset by issuing a write of any value to the I<sup>2</sup>C RESET register (Figure 23). Note: The execution of the I<sup>2</sup>C reset command is equivalent to toggling the Resetb pin of the chip. Refer to the Resetb Signal, RESET Command via JTAG or I<sup>2</sup>C section of this data sheet for further information.

**Figure 23. I<sup>2</sup>C Reset Register**
**0x12 - RESET (Write Only)**

X	X	X	X	X	X	X	X
b7	b6	b5	b4	b3	b2	b1	b0

### SMBus SMBAlert Function

The ispPAC-POWR1014A provides an SMBus SMBAlert function so that it can request service from the bus master when it is used as part of an SMBus system. This feature is supported as an alternate function of OUT3. When the SMBAlert feature is enabled, OUT3 is controlled by a combination of the PLD output and the GP3\_ENb bit (Figure 24). Note: To enable the SMBAlert feature, the SMB\_Mode (EECMOS bit) should be set in software.

**Figure 24. ispPAC-POWR1014/A SMBAlert Logic**

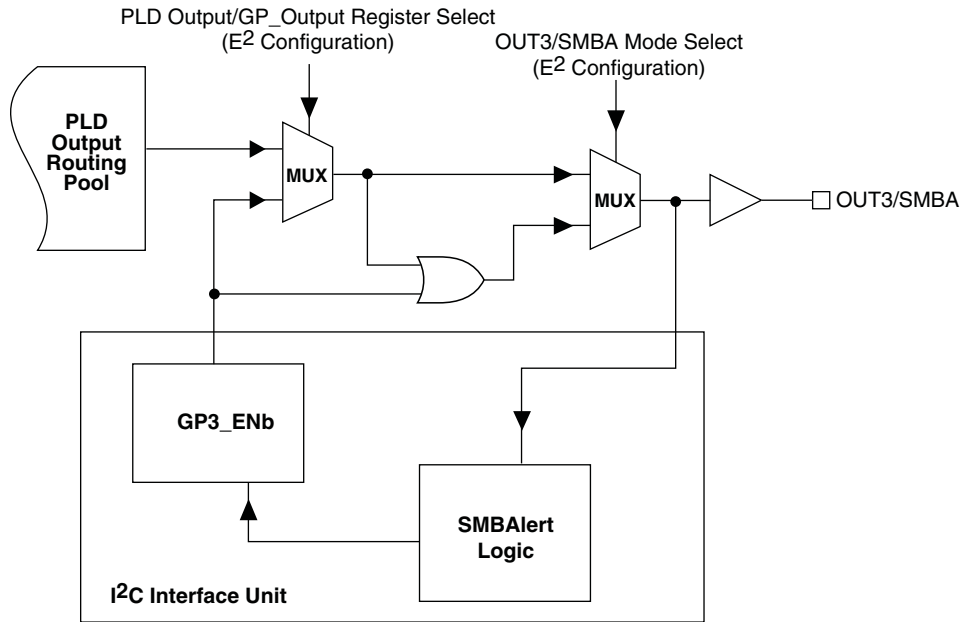

The typical flow for an SMBAlert transaction is as follows (Figure 24):

1. GP3\_ENb bit is forced (Via I<sup>2</sup>C write) to Low
2. ispPAC-POWR1014A PLD Logic pulls OUT3/SMBA Low
3. Master responds to interrupt from SMBA line
4. Master broadcasts a read operation using the SMBus Alert Response Address (ARA)
5. ispPAC-POWR1014A responds to read request by transmitting its device address
6. If transmitted device address matches ispPAC-POWR1014A address, it sets GP3\_ENb bit high. This releases OUT3/SMBA.

**Figure 25. SMBAlert Bus Transaction**

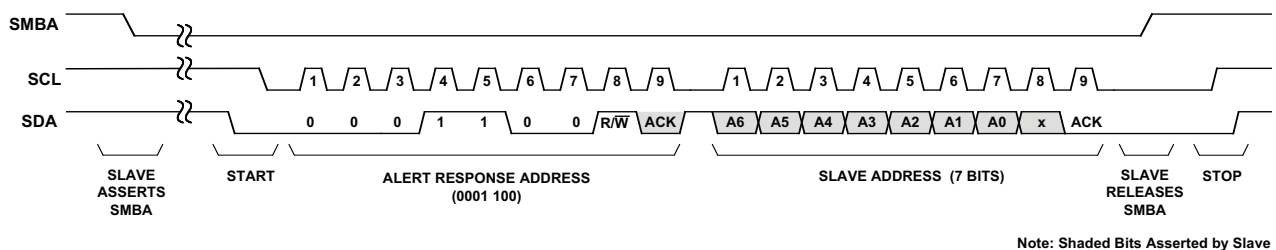

After OUT3/SMBA has been released, the bus master (typically a microcontroller) may opt to perform some service functions in which it may send data to or read data from the ispPAC-POWR1014A. As part of the service functions, the bus master will typically need to clear whatever condition initiated the SMBAlert request, and will also need to reset GP3\_ENb to re-enable the SMBAlert function. For further information on the SMBus, the user should consult the SMBus Standard.

## Software-Based Design Environment

Designers can configure the ispPAC-POWR1014/A using PAC-Designer, an easy to use, Microsoft Windows compatible program. Circuit designs are entered graphically and then verified, all within the PAC-Designer environment. Full device programming is supported using PC parallel port I/O operations and a download cable connected to the serial programming interface pins of the ispPAC-POWR1014/A. A library of configurations is included with basic solutions and examples of advanced circuit techniques are available on the Lattice web site for downloading. In addition, comprehensive online and printed documentation is provided that covers all aspects of PAC-Designer operation. The PAC-Designer schematic window, shown in Figure 26, provides access to all configurable ispPAC-POWR1014/A elements via its graphical user interface. All analog input and output pins are represented. Static or non-configurable pins such as power, ground, and the serial digital interface are omitted for clarity. Any element in the schematic window can be accessed via mouse operations as well as menu commands. When completed, configurations can be saved, simulated, and downloaded to devices.

Figure 26. PAC-Designer ispPAC-POWR1014/A Design Entry Screen

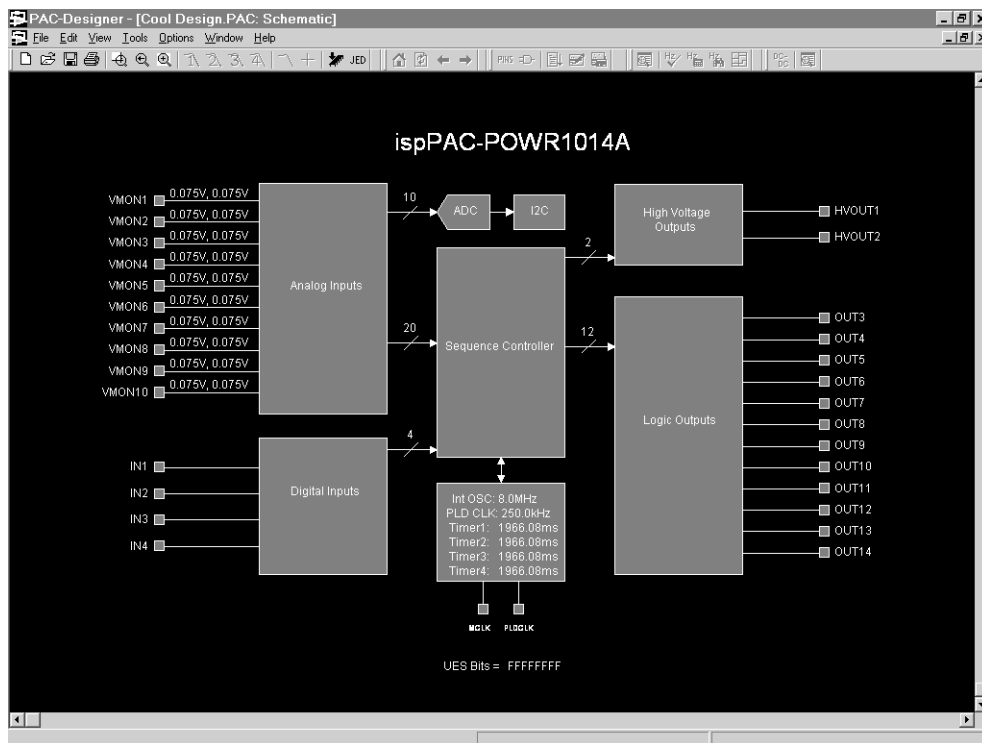

## In-System Programming

The ispPAC-POWR1014/A is an in-system programmable device. This is accomplished by integrating all E<sup>2</sup> configuration memory and control logic on-chip. Programming is performed through a 4-wire, IEEE 1149.1 compliant serial JTAG interface at normal logic levels (see Figure 27). Once a device is programmed, all configuration information is stored on-chip, in non-volatile E<sup>2</sup>CMOS memory cells. The specifics of the IEEE 1149.1 serial interface and all ispPAC-POWR1014/A instructions are described in the JTAG interface section of this data sheet.

Figure 27. ispPAC-POWR1014/A JTAG Interconnection Configuration Diagram

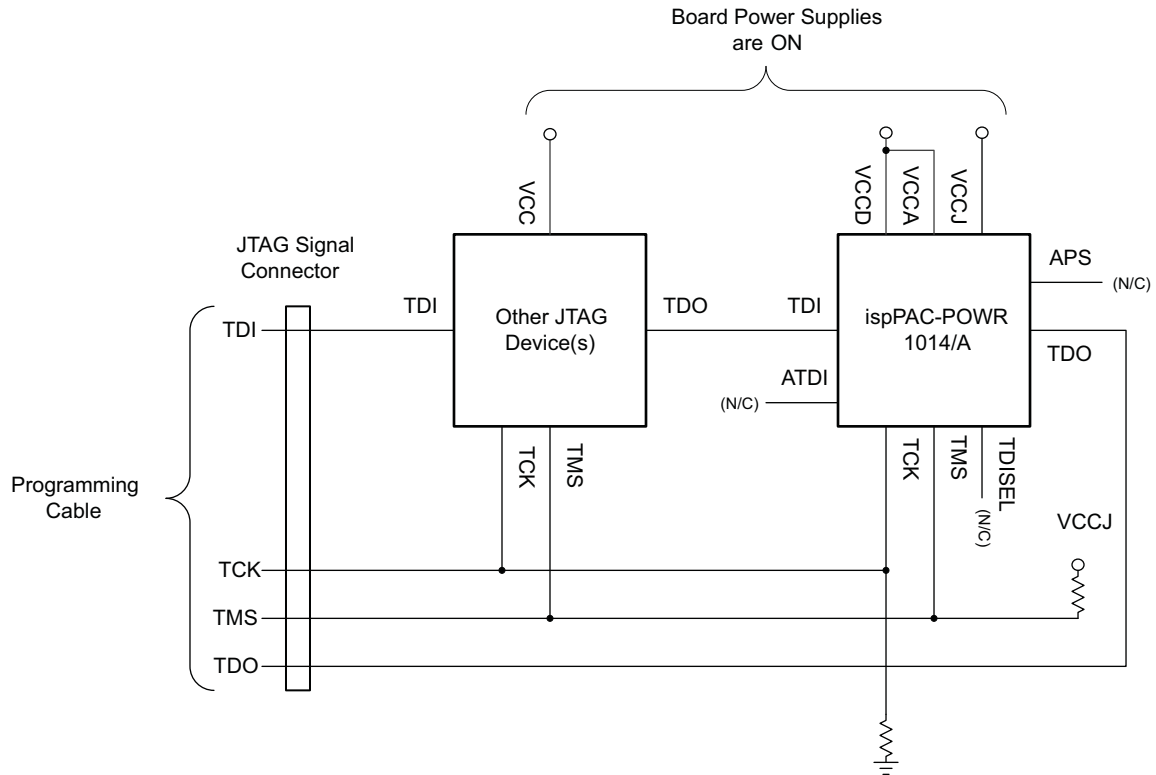

## Programming ispPAC-POWR1014/A: Alternate Method

Some applications require that the ispPAC-POWR1014/A be programmed before turning the power on to the entire circuit board. To meet such application needs, the ispPAC-POWR1014/A provides an alternate programming method which enables the programming of the ispPAC-POWR1014/A device through the JTAG chain with a separate power supply applied just to the programming section of the ispPAC-POWR1014/A device with the main power supply of the board turned off.

Three special purpose pins, APS, ATDI and TDISEL, enable programming of the unprogrammed ispPAC-POWR1014/A under such circumstances. The APS pin provides power to the programming circuitry of the ispPAC-POWR1014/A device (when VCCD and VCCA are unpowered). The VCCJ pin must be powered to enable the JTAG port. The ATDI pin provides an alternate connection to the JTAG header while bypassing all the unpowered devices in the JTAG chain. TDISEL pin enables switching between the ATDI and the standard JTAG signal TDI. When the internally pulled-up TDISEL = 1, standard TDI pin is enabled and when the TDISEL = 0, ATDI is enabled.

In order to use this feature the JTAG signals of the ispPAC-POWR1014/A are connected to the header as shown in Figure 28. Note: The ispPAC-POWR1014/A should be the last device in the JTAG chain.

After programming, the APS pin MUST be left floating before applying power to the VCCD and VCCA pins.

Figure 28. ispPAC-POWR1014/A Alternate Configuration Diagram

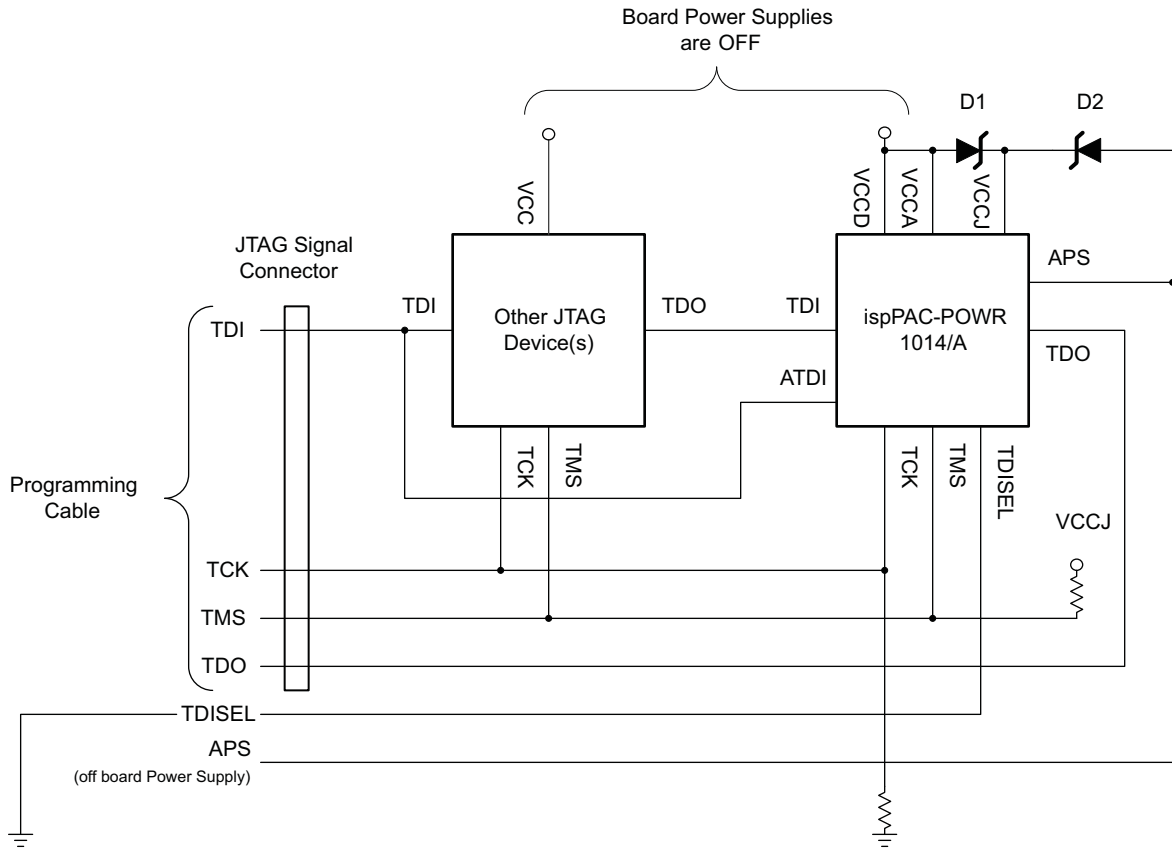

### Alternate TDI Selection Via JTAG Command

When the TDISEL pin held high and four consecutive IDCODE instructions are issued, ispPAC-POWR1014/A responds by making its active JTAG data input the ATDI pin. When ATDI is selected, data on its TDI pin is ignored until the JTAG state machine returns to the Test-Logic-Reset state.

This method of selecting ATDI takes advantage of the fact that a JTAG device with an IDCODE register will automatically load its unique IDCODE instruction into the Instruction Register after a Test-Logic-Reset. This JTAG capability permits blind interrogation of devices so that their location in a serial chain can be identified without having to know anything about them in advance. A blind interrogation can be made using only the TMS and TCLK control pins, which means TDI and TDO are not required for performing the operation. Figure 29 illustrates the logic for selecting whether the TDI or ATDI pin is the active data input to ispPAC-POWR1014/A.

**Figure 29. ispPAC-POWR1014/A TDI/ATDI Pin Selection Diagram**

Table 10 shows in truth table form the same conditions required to select either TDI or ATDI as in the logic diagram found in Figure 29.

**Table 10. ispPAC-POWR1014/A ATDI/TDI Selection Table**

TDISEL Pin	JTAG State Machine Test-Logic-Reset	4 Consecutive IDCODE Commands Loaded at Update-IR	Active JTAG Data Input Pin
H	No	Yes	ATDI (TDI Disabled)
H	Yes	No	TDI (ATDI Disabled)
L	X	X	ATDI (TDI Disabled)

Please refer to AN6068, [Programming the ispPAC-POWR1220AT8 in a JTAG Chain Using ATDI](#). This application note includes specific SVF code examples and information on the use of Lattice design tools to verify device operation in alternate TDI mode.

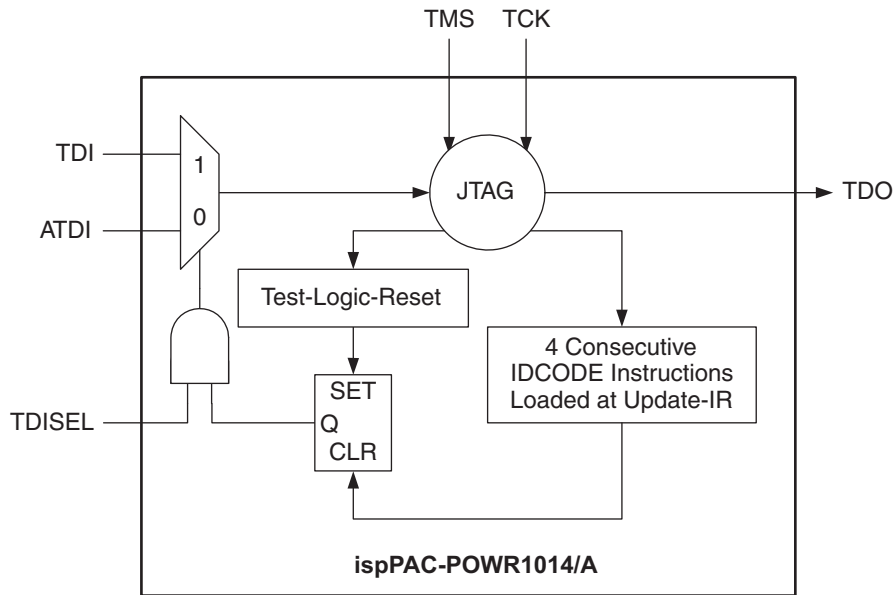
### APS Alternate Programming Supply Pin

Because the APS pin directly powers the on-chip programming circuitry, the ispPAC-POWR1014/A device can be programmed by applying power to the APS pin (without powering the entire chip though the VCCD and VCCA pins). In addition, to enable the on-chip JTAG interface circuitry, power should be applied to the VCCJ pin.

When the ispPAC-POWR1014/A is powered by the APS pin, no power should be applied to the VCCD and VCCA pins. Additionally, other than JTAG I/O pins, all digital output pins are in Hi-Z state, HVOUT pins configured as MOSFET driver are driven low, and all other inputs are ignored.

To switch the power supply back to VCCD and VCCA pins, one should turn the APS supply and VCCJ off before turning the regular supplies on. When VCCD and VCCA are turned back on for normal operation, APS MUST be left floating.

The APS pin should not be connected to the VCCD and VCCA pins.

## User Electronic Signature

A user electronic signature (UES) feature is included in the E<sup>2</sup>CMOS memory of the ispPAC-POWR1014/A. This consists of 32 bits that can be configured by the user to store unique data such as ID codes, revision numbers or inventory control data. The specifics of this feature are discussed in the IEEE 1149.1 serial interface section of this data sheet.

## Electronic Security

An electronic security “fuse” (ESF) bit is provided in every ispPAC-POWR1014/A device to prevent unauthorized readout of the E<sup>2</sup>CMOS configuration bit patterns. Once programmed, this cell prevents further access to the functional user bits in the device. This cell can only be erased by reprogramming the device, so the original configuration cannot be examined once programmed. Usage of this feature is optional. The specifics of this feature are discussed in the IEEE 1149.1 serial interface section of this data sheet.

## Production Programming Support

Once a final configuration is determined, an ASCII format JEDEC file can be created using the PAC-Designer software. Devices can then be ordered through the usual supply channels with the user’s specific configuration already preloaded into the devices. By virtue of its standard interface, compatibility is maintained with existing production programming equipment, giving customers a wide degree of freedom and flexibility in production planning.

## Evaluation Fixture

Because the features of an ispPAC-POWR1014/A are all included in the larger ispPAC-POWR1220AT8 device, designs implemented in an ispPAC-POWR1014/A can be verified using an ispPAC-POWR1220AT8 engineering prototype board connected to the parallel port of a PC with a Lattice ispDOWNLOAD™ cable. The board demonstrates proper layout techniques and can be used in real time to check circuit operation as part of the design process. Input and output connections are provided to aid in the evaluation of the functionality implemented in ispPAC-POWR1014/A for a given application. (Figure 30).

**Figure 30. Download from a PC**

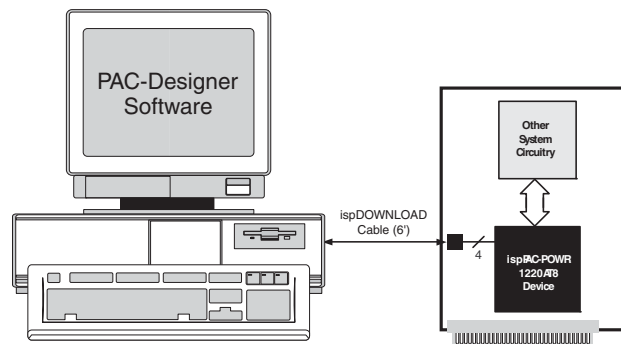

## IEEE Standard 1149.1 Interface (JTAG)

Serial Port Programming Interface Communication with the ispPAC-POWR1014/A is facilitated via an IEEE 1149.1 test access port (TAP). It is used by the ispPAC-POWR1014/A as a serial programming interface. A brief description of the ispPAC-POWR1014/A JTAG interface follows. For complete details of the reference specification, refer to the publication, Standard Test Access Port and Boundary-Scan Architecture, IEEE Std 1149.1-1990 (which now includes IEEE Std 1149.1a-1993).

## Overview

An IEEE 1149.1 test access port (TAP) provides the control interface for serially accessing the digital I/O of the ispPAC-POWR1014/A. The TAP controller is a state machine driven with mode and clock inputs. Given in the correct sequence, instructions are shifted into an instruction register, which then determines subsequent data input, data

output, and related operations. Device programming is performed by addressing the configuration register, shifting data in, and then executing a program configuration instruction, after which the data is transferred to internal E<sup>2</sup>CMOS cells. It is these non-volatile cells that store the configuration or the ispPAC-POWR1014/A. A set of instructions are defined that access all data registers and perform other internal control operations. For compatibility between compliant devices, two data registers are mandated by the IEEE 1149.1 specification. Others are functionally specified, but inclusion is strictly optional. Finally, there are provisions for optional data registers defined by the manufacturer. The two required registers are the bypass and boundary-scan registers. Figure 31 shows how the instruction and various data registers are organized in an ispPAC-POWR1014/A.

**Figure 31. ispPAC-POWR1014/A TAP Registers**

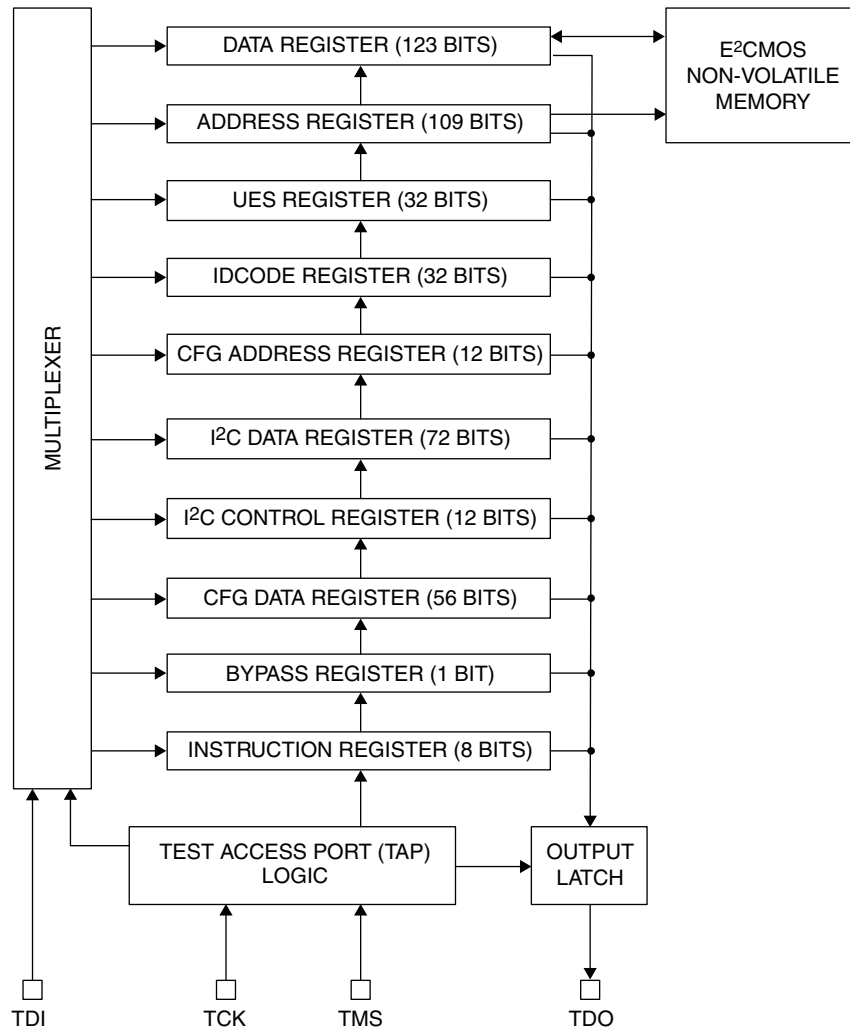

### TAP Controller Specifics

The TAP is controlled by the Test Clock (TCK) and Test Mode Select (TMS) inputs. These inputs determine whether an Instruction Register or Data Register operation is performed. Driven by the TCK input, the TAP consists of a small 16-state controller design. In a given state, the controller responds according to the level on the TMS input as shown in Figure 32. Test Data In (TDI) and TMS are latched on the rising edge of TCK, with Test Data Out (TDO) becoming valid on the falling edge of TCK. There are six steady states within the controller: Test-Logic-Reset, Run-Test/Idle, Shift-Data-Register, Pause-Data-Register, Shift-Instruction-Register and Pause-Instruction-Register. But there is only one steady state for the condition when TMS is set high: the Test-Logic-Reset state. This allows a reset of the test logic within five TCKs or less by keeping the TMS input high. Test-Logic-Reset is the power-on default state.

Figure 32. TAP States

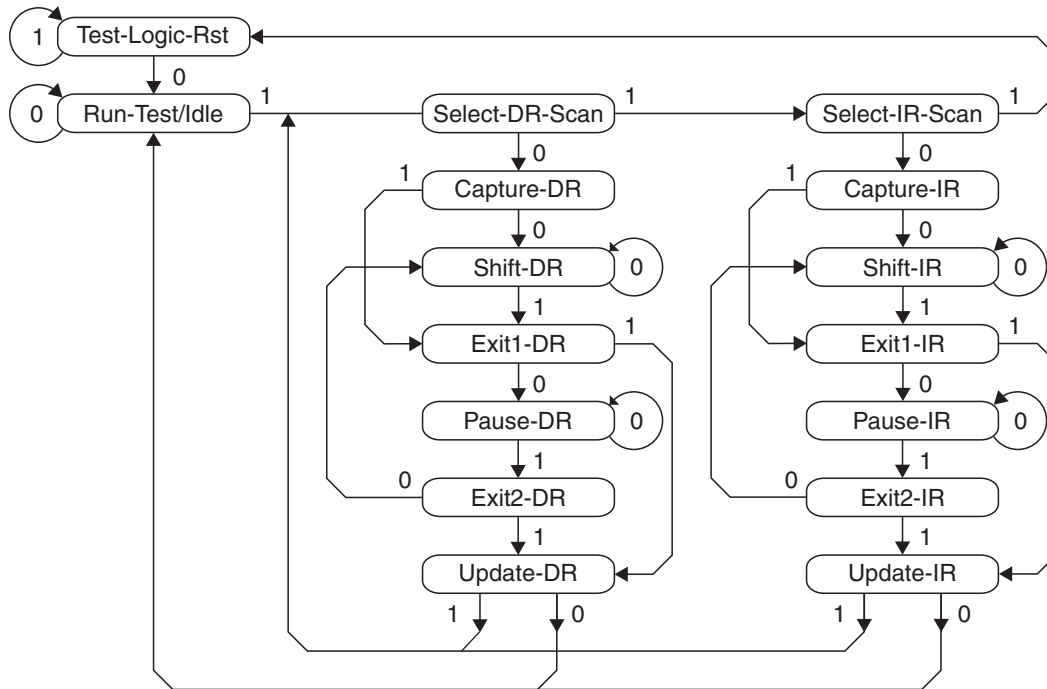

Note: The value shown adjacent to each state transition in this figure represents the signal present at TMS at the time of a rising edge at TCK.

When the correct logic sequence is applied to the TMS and TCK inputs, the TAP will exit the Test-Logic-Reset state and move to the desired state. The next state after Test-Logic-Reset is Run-Test/Idle. Until a data or instruction shift is performed, no action will occur in Run-Test/Idle (steady state = idle). After Run-Test/Idle, either a data or instruction shift is performed. The states of the Data and Instruction Register blocks are identical to each other differing only in their entry points. When either block is entered, the first action is a capture operation. For the Data Registers, the Capture-DR state is very simple: it captures (parallel loads) data onto the selected serial data path (previously chosen with the appropriate instruction). For the Instruction Register, the Capture-IR state will always load the IDCODE instruction. It will always enable the ID Register for readout if no other instruction is loaded prior to a Shift-DR operation. This, in conjunction with mandated bit codes, allows a “blind” interrogation of any device in a compliant IEEE 1149.1 serial chain. From the Capture state, the TAP transitions to either the Shift or Exit1 state. Normally the Shift state follows the Capture state so that test data or status information can be shifted out or new data shifted in. Following the Shift state, the TAP either returns to the Run-Test/Idle state via the Exit1 and Update states or enters the Pause state via Exit1. The Pause state is used to temporarily suspend the shifting of data through either the Data or Instruction Register while an external operation is performed. From the Pause state, shifting can resume by reentering the Shift state via the Exit2 state or be terminated by entering the Run-Test/Idle state via the Exit2 and Update states. If the proper instruction is shifted in during a Shift-IR operation, the next entry into Run-Test/Idle initiates the test mode (steady state = test). This is when the device is actually programmed, erased or verified. All other instructions are executed in the Update state.

## Test Instructions

Like data registers, the IEEE 1149.1 standard also mandates the inclusion of certain instructions. It outlines the function of three required and six optional instructions. Any additional instructions are left exclusively for the manufacturer to determine. The instruction word length is not mandated other than to be a minimum of two bits, with only the BYPASS and EXTEST instruction code patterns being specifically called out (all ones and all zeroes respectively). The ispPAC-POWR1014/A contains the required minimum instruction set as well as one from the optional instruction set. In addition, there are several proprietary instructions that allow the device to be configured and verified. Table 11 lists the instructions supported by the ispPAC-POWR1014/A JTAG Test Access Port (TAP) controller.

**Table 11. ispPAC-POWR1014/A TAP Instruction Table**

Instruction	Command Code	Comments
BULK_ERASE	0000 0011	Bulk erase device
BYPASS	1111 1111	Bypass - connects TDO to TDI
DISCHARGE	0001 0100	Fast VPP discharge
ERASE_DONE_BIT	0010 0100	Erases 'Done' bit only
I2C_DATA_REGISTER	0010 0101	Accessing I <sup>2</sup> C data register through JTAG (72 bits)
I2C_CONTROL_REGISTER	0010 0110	Controls read and write functions of I <sup>2</sup> C registers (12 bits)
EXTEST	0000 0000	Bypass - connect TDO to TDI
IDCODE	0001 0110	Read contents of manufacturer ID code (32 bits)
OUTPUTS_HIGHZ	0001 1000	Force all outputs to High-Z state, FET outputs pulled low
SAMPLE/PRELOAD	0001 1100	Sample/Preload. Default to bypass.
PROGRAM_DISABLE	0001 1110	Disable program mode
PROGRAM_DONE_BIT	0010 1111	Programs the Done bit
PROGRAM_ENABLE	0001 0101	Enable program mode
PROGRAM_SECURITY	0000 1001	Program security fuse
RESET	0010 0010	Resets device (refer to the RESETb Signal, RESET Command via JTAG or I2C section of this data sheet)
IN1_RESET_JTAG_BIT	0001 0010	Reset the JTAG bit associated with IN1 pin to 0
IN1_SET_JTAG_BIT	0001 0011	Set the JTAG bit associated with IN1 pin to 1
CFG_ADDRESS	0010 1011	Select non-PLD address register
CFG_DATA_SHIFT	0010 1101	Non-PLD data shift
CFG_ERASE	0010 1001	ERASE just the non-PLD configuration
CFG_PROGRAM	0010 1110	Non-PLD program
CFG_VERIFY	0010 1000	VERIFY non-PLD fusemap data
PLD_ADDRESS_SHIFT	0000 0001	PLD_Address register (109 bits)
PLD_DATA_SHIFT	0000 0010	PLD_Data register (123 bits)
PLD_INIT_ADDR_FOR_PROG_INCR	0010 0001	Initialize the address register for auto increment
PLD_PROG_INCR	0010 0111	Program column register to E <sup>2</sup> and auto increment address register
PLD_PROGRAM	0000 0111	Program PLD data register to E <sup>2</sup>
PLD_VERIFY	0000 1010	Verifies PLD column data
PLD_VERIFY_INCR	0010 1010	Load column register from E <sup>2</sup> and auto increment address register
UES_PROGRAM	0001 1010	Program UES bits into E <sup>2</sup>
UES_READ	0001 0111	Read contents of UES register from E <sup>2</sup> (32 bits)

**BYPASS** is one of the three required instructions. It selects the Bypass Register to be connected between TDI and TDO and allows serial data to be transferred through the device without affecting the operation of the ispPAC-POWR1014/A. The IEEE 1149.1 standard defines the bit code of this instruction to be all ones (11111111).

The required **SAMPLE/PRELOAD** instruction dictates the Boundary-Scan Register be connected between TDI and TDO. The ispPAC-POWR1014/A has no boundary scan register, so for compatibility it defaults to the BYPASS mode whenever this instruction is received. The bit code for this instruction is defined by Lattice as shown in Table 11.

The **EXTEST** (external test) instruction is required and would normally place the device into an external boundary test mode while also enabling the boundary scan register to be connected between TDI and TDO. Again, since the

ispPAC-POWR1014/A has no boundary scan logic, the device is put in the BYPASS mode to ensure specification compatibility. The bit code of this instruction is defined by the 1149.1 standard to be all zeros (00000000).

The optional **IDCODE** (identification code) instruction is incorporated in the ispPAC-POWR1014/A and leaves it in its functional mode when executed. It selects the Device Identification Register to be connected between TDI and TDO. The Identification Register is a 32-bit shift register containing information regarding the IC manufacturer, device type and version code (Figure 33). Access to the Identification Register is immediately available, via a TAP data scan operation, after power-up of the device, or by issuing a Test-Logic-Reset instruction. The bit code for this instruction is defined by Lattice as shown in Table 11.

**Figure 33. ispPAC-POWR1014/A ID Code**

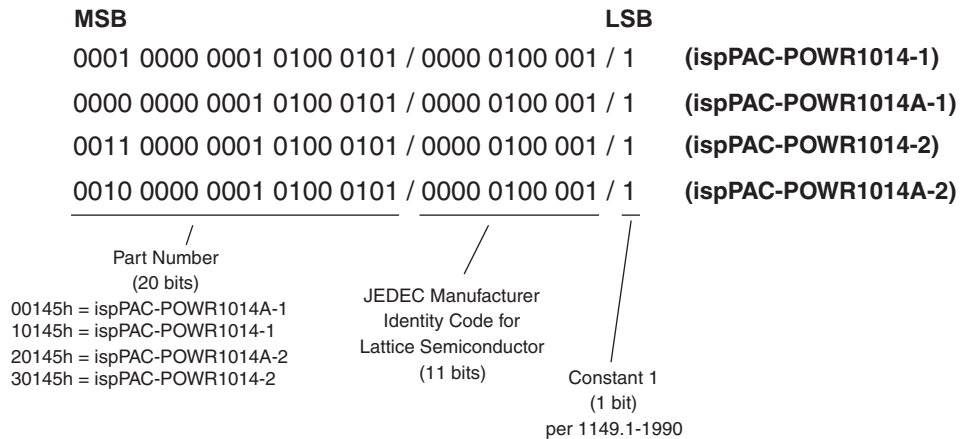

### ispPAC-POWR1014/A Specific Instructions

There are 25 unique instructions specified by Lattice for the ispPAC-POWR1014/A. These instructions are primarily used to interface to the various user registers and the E<sup>2</sup>CMOS non-volatile memory. Additional instructions are used to control or monitor other features of the device. A brief description of each unique instruction is provided in detail below, and the bit codes are found in Table 11.

**PLD\_ADDRESS\_SHIFT** – This instruction is used to set the address of the PLD AND/ARCH arrays for subsequent program or read operations. This instruction also forces the outputs into the OUTPUTS\_HIGHZ.

**PLD\_DATA\_SHIFT** – This instruction is used to shift PLD data into the register prior to programming or reading. This instruction also forces the outputs into the OUTPUTS\_HIGHZ.

**PLD\_INIT\_ADDR\_FOR\_PROG\_INCR** – This instruction prepares the PLD address register for subsequent PLD\_PROG\_INCR or PLD\_VERIFY\_INCR instructions.

**PLD\_PROG\_INCR** – This instruction programs the PLD data register for the current address and increments the address register for the next set of data.

**PLD\_PROGRAM** – This instruction programs the selected PLD AND/ARCH array column. The specific column is preselected by using PLD\_ADDRESS\_SHIFT instruction. The programming occurs at the second rising edge of the TCK in Run-Test-Idle JTAG state. The device must already be in programming mode (PROGRAM\_ENABLE instruction). This instruction also forces the outputs into the OUTPUTS\_HIGHZ.

**PROGRAM\_SECURITY** – This instruction is used to program the electronic security fuse (ESF) bit. Programming the ESF bit protects proprietary designs from being read out. The programming occurs at the second rising edge of the TCK in Run-Test-Idle JTAG state. The device must already be in programming mode (PROGRAM\_ENABLE instruction). This instruction also forces the outputs into the OUTPUTS\_HIGHZ.

**PLD\_VERIFY** – This instruction is used to read the content of the selected PLD AND/ARCH array column. This specific column is preselected by using PLD\_ADDRESS\_SHIFT instruction. This instruction also forces the outputs into the OUTPUTS\_HIGHZ.

**DISCHARGE** – This instruction is used to discharge the internal programming supply voltage after an erase or programming cycle and prepares ispPAC-POWR1014/A for a read cycle. This instruction also forces the outputs into the OUTPUTS\_HIGHZ.

**CFG\_ADDRESS** – This instruction is used to set the address of the CFG array for subsequent program or read operations. This instruction also forces the outputs into the OUTPUTS\_HIGHZ.

**CFG\_DATA\_SHIFT** – This instruction is used to shift data into the CFG register prior to programming or reading. This instruction also forces the outputs into the OUTPUTS\_HIGHZ.

**CFG\_ERASE** – This instruction will bulk erase the CFG array. The action occurs at the second rising edge of TCK in Run-Test-Idle JTAG state. The device must already be in programming mode (PROGRAM\_ENABLE instruction). This instruction also forces the outputs into the OUTPUTS\_HIGHZ.

**CFG\_PROGRAM** – This instruction programs the selected CFG array column. This specific column is preselected by using CFG\_ADDRESS instruction. The programming occurs at the second rising edge of the TCK in Run-Test-Idle JTAG state. The device must already be in programming mode (PROGRAM\_ENABLE instruction). This instruction also forces the outputs into the OUTPUTS\_HIGHZ.

**CFG\_VERIFY** – This instruction is used to read the content of the selected CFG array column. This specific column is preselected by using CFG\_ADDRESS instruction. This instruction also forces the outputs into the OUTPUTS\_HIGHZ.

**BULK\_ERASE** – This instruction will bulk erase all E<sup>2</sup>CMOS bits (CFG, PLD, UES, and ESF) in the ispPAC-POWR1014/A. The device must already be in programming mode (PROGRAM\_ENABLE instruction). This instruction also forces the outputs into the OUTPUTS\_HIGHZ.

**OUTPUTS\_HIGHZ** – This instruction turns off all of the open-drain output transistors. Pins that are programmed as FET drivers will be placed in the active low state. This instruction is effective after Update-Instruction-Register JTAG state.

**PROGRAM\_ENABLE** – This instruction enables the programming mode of the ispPAC-POWR1014/A. This instruction also forces the outputs into the OUTPUTS\_HIGHZ.

**IDCODE** – This instruction connects the output of the Identification Code Data Shift (IDCODE) Register to TDO (Figure 34), to support reading out the identification code.

**Figure 34. IDCODE Register**

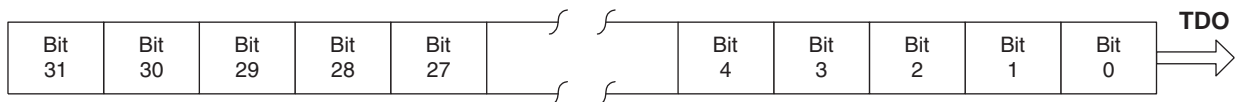

**PROGRAM\_DISABLE** – This instruction disables the programming mode of the ispPAC-POWR1014/A. The Test-Logic-Reset JTAG state can also be used to cancel the programming mode of the ispPAC-POWR1014/A.

**UES\_READ** – This instruction both reads the E<sup>2</sup>CMOS bits into the UES register and places the UES register between the TDI and TDO pins (as shown in Figure 31), to support programming or reading of the user electronic signature bits.

**Figure 35. UES Register**

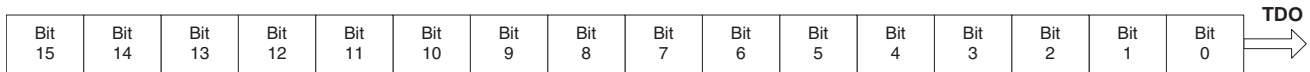

**UES\_PROGRAM** – This instruction will program the content of the UES Register into the UES E<sup>2</sup>CMOS memory. The device must already be in programming mode (PROGRAM\_ENABLE instruction). This instruction also forces the outputs into the OUTPUTS\_HIGHZ.

**ERASE\_DONE\_BIT** – This instruction clears the 'Done' bit, which prevents the ispPAC-POWR1014/A sequence from starting.

**PROGRAM\_DONE\_BIT** – This instruction sets the 'Done' bit, which enables the ispPAC-POWR1014/A sequence to start.

**RESET** – This instruction resets the PLD sequence and output macrocells.

**IN1\_RESET\_JTAG\_BIT** – This instruction clears the JTAG Register logic input 'IN1'. The PLD input has to be configured to take input from the JTAG Register in order for this command to have effect on the sequence.

**IN1\_SET\_JTAG\_BIT** – This instruction sets the JTAG Register logic input 'IN1'. The PLD input has to be configured to take input from the JTAG Register in order for this command to have effect on the sequence.

**PLD\_VERIFY\_INCR** – This instruction reads out the PLD data register for the current address and increments the address register for the next read.

**Notes:**

In all of the descriptions above, OUTPUTS\_HIGHZ refers both to the instruction and the state of the digital output pins, in which the open-drains are tri-stated and the FET drivers are pulled low.

Before any of the above programming instructions are executed, the respective E<sup>2</sup>CMOS bits need to be erased using the corresponding erase instruction.

**Accessing I<sup>2</sup>C Registers through JTAG (ispPAC-POWR1014A Only)**

I<sup>2</sup>C registers can be read or written through the JTAG interface of the ispPAC-POWR1014A devices using the two JTAG command codes shown in Table 12.

*Note: The SCL pin of the I<sup>2</sup>C port should be pulled high during the entire time that the I<sup>2</sup>C registers are being accessed via the JTAG port.*

**Table 12. JTAG Command Codes**

Instruction	Command Code	Comments
I2C_DATA_REGISTER	0010 0101	Accessing I <sup>2</sup> C Data Register Through JTAG (72 Bits)
I2C_CONTROL_REGISTER	0010 0110	Controls Read and Write Functions of I <sup>2</sup> C Registers (12 Bits)

There are 12 bits in the I2C\_Control\_Register and 72 bits in the I2C\_Data\_Register packet. All I<sup>2</sup>C register contents, except the UES bits, can be read out through the 72-bit I2C\_Data\_Register packet. All I<sup>2</sup>C write registers can be written by shifting in a 72-bit I2C\_Data\_Register packet. The I2C\_Control\_Register bits are used to select the I<sup>2</sup>C registers read as well as written.

The reading (shifting out) and writing (shifting in) of I2C\_Data\_Register and writing of the I2C\_Control\_Register through the JTAG port follows the TAP states protocol shown in Figure 32.

## I2C\_Control\_Register Structure

Figure 36 shows the functions of each of the 12-bit I2C\_Control\_Register bits.

**Figure 36. I2C\_Control\_Register**

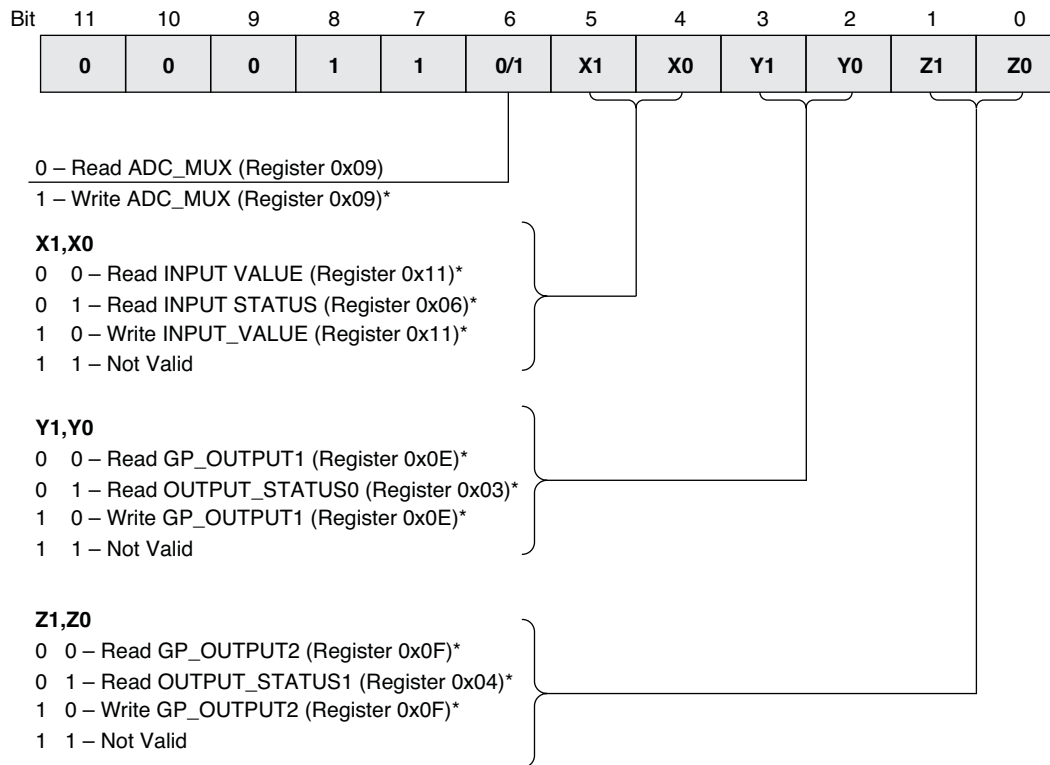

\*Equivalent I<sup>2</sup>C port addresses are shown in parentheses.

## I2C\_Data\_Register Packet Structure

The 72-bit I2C\_Data\_Register packet is divided into 9 bytes.

- Bytes 9-7 contain the VMON status
- Bytes 6-5 contain ADC result
- Byte 4 controls/reads ADC Mux and ADC Input Attenuator
- Byte 3 controls/reads input pins/ status
- Bytes 2-1 control/read output pins/status

## VMON Status Registers

**Byte 9, Byte 8 and Byte 7:** Byte 9 is the most significant byte and is shifted out last, ending with bit 71, VMON1A. These bytes consist of the status of VMONxA and VMONxB comparators corresponding to VMON1 through VMON10 inputs. In the following tables, the number in the parenthesis indicates the bit position within the I2C\_Data\_Register Packet. During the I2C\_Data\_Register write operation, the contents of these bytes are ignored because the VMON status registers are read only.

**Figure 37. VMON Status Registers**
**Byte 9 – VMON\_STATUS0 (Read Only, Most Significant), I<sup>2</sup>C Address = 0x00**

VMON1A (71)	VMON1B (70)	VMON2A (69)	VMON2B (68)	VMON3A (67)	VMON3B (66)	VMON4A (65)	VMON4B (64)
----------------	----------------	----------------	----------------	----------------	----------------	----------------	----------------

**Byte 8 – VMON\_STATUS1 (Read Only), I<sup>2</sup>C Address = 0x01**

VMON5A (63)	VMON5B (62)	VMON6A (61)	VMON6B (60)	VMON7A (59)	VMON7B (58)	VMON8A (57)	VMON8B (56)
----------------	----------------	----------------	----------------	----------------	----------------	----------------	----------------

**Byte 7 – VMON\_STATUS2 (Read Only), I<sup>2</sup>C Address = 0x02**

VMON9A (55)	VMON9B (54)	VMON10A (53)	VMON10B (52)	1 (51)	1 (50)	1 (49)	1 (48)
----------------	----------------	-----------------	-----------------	-----------	-----------	-----------	-----------

### ADC Interface Registers

**Byte 6, Byte 5:** These bytes contain 12-bit ADC measured values.

**Figure 38. ADC Interface Registers, Bytes 6 and 5**
**Byte 6 – ADC\_Value\_Low (Read Only), I<sup>2</sup>C Address = 0x07**

X (47)	1 (46)	1 (45)	1 (44)	D0 (43)	D1 (42)	D2 (41)	D3 (40)
-----------	-----------	-----------	-----------	------------	------------	------------	------------

**Byte 5 – ADC\_Value\_High (Read Only), I<sup>2</sup>C Address = 0x08**

D4 (39)	D5 (38)	D6 (37)	D7 (36)	D8 (35)	D9 (34)	D10 (33)	D11 (32)
------------	------------	------------	------------	------------	------------	-------------	-------------

**Byte 4:** The I2C\_Data\_Register write operation action is determined by bit 6 of the I2C\_Control\_Register. When bit 6 of the I2C\_Control\_Register is set to 1, this byte selects the VMON input for routing to the ADC (4-bit ADC input mux) and sets/clears the ADC attenuate mode. When the bit 6 of the I2C\_Control\_register is reset to 0, the contents of the Byte 4 are ignored. During I2C\_Data\_Register read operation with bit 6 reset to 0 in the I2C\_Control\_Register, byte 4 returns the 4-bit input mux setting and the attenuate bit setting. Refer to Tables 8 and 9 for the mux select and the attenuate bits decode value.

**Figure 39. ADC Interface Registers, Byte 4**
**Byte 4 – ADC\_MUX (Read/ Write), I<sup>2</sup>C Address = 0x09**

SEL0 (31)	SEL1 (30)	SEL2 (29)	SEL3 (28)	ATTEN (27)	X (26)	X (25)	X (24)
--------------	--------------	--------------	--------------	---------------	-----------	-----------	-----------

### Digital Input Status and Input Value Register

**Byte 3:** I2C\_Control\_Register bits 5 and 4 control reading into and writing from Byte 3 of the I2C\_Data\_Register. When bits 5 and 4 are set to 10b, the contents of Byte 3 are written into the input register bits during the I2C\_Data\_Register write operation.

**Figure 40. INPUT\_VALUE Registers, Byte 3**
**Byte 3 – INPUT\_VALUE (Write Operation) – When I2C\_Control\_Register bit 5 =1, bit 4=0, I<sup>2</sup>C Address = 0x11**

X (23)	I2 (22)	I3 (21)	I4 (20)	1 (19)	1 (18)	1 (17)	1 (16)
-----------	------------	------------	------------	-----------	-----------	-----------	-----------

During the I2C\_Data\_Register read operation - When I2C\_Control\_Register bit 5 = 0, and bit 4 = 0, the Byte 3 value will return INPUT\_VALUE register.

**Byte 3 – INPUT\_VALUE (Read operation) – When I2C\_Control\_Register Bit 5=0 and Bit 4=0, I<sup>2</sup>C Address = 0x11**

X (23)	I <sup>2</sup> (22)	I <sup>3</sup> (21)	I <sup>4</sup> (20)	1 (19)	1 (18)	1 (17)	1 (16)
-----------	------------------------	------------------------	------------------------	-----------	-----------	-----------	-----------

During the I2C\_Data\_Register read operation - When I2C\_Control\_Register bit 5 = 0, and bit 4 = 1 Byte 3 value will return INPUT\_STATUS register.

**Byte 3 – INPUT\_STATUS (Read operation) – When I2C\_Control\_Register Bit 5=0 and Bit 4=1, I<sup>2</sup>C Address = 0x06**

X (23)	IN <sup>2</sup> (22)	IN <sup>3</sup> (21)	IN <sup>4</sup> (20)	1 (19)	1 (18)	1 (17)	1 (16)
-----------	-------------------------	-------------------------	-------------------------	-----------	-----------	-----------	-----------

### Output Status and GP\_Output Registers

**Byte 2, Byte 1:** These bytes control the digital outputs and HVOUT outputs during the write operation. The Output Status and GP\_Output register association with the outputs are shown in Figure 21. During the write operation, the Gp\_Output 1 and Gp\_Output 2 registers are written with values specified in Byte 2 and Byte 1, when the I2C\_Control\_Register bits 3 and 2 are set to 0x10b and bits 1 and 0 are set to 0x10b. During the I2C\_Data\_Register read operation (I2C\_Control\_Register bits 3 and 2 = 0x00b and bits 1 and 0 = 0x00b), Byte 2 and Byte 1 return the GP\_Output registers. If I2C\_Control\_Register bits 3 and 2 = 0x01b and bits 1 and 0 = 0x01b, Byte 2 and Byte 1 will return the OUTPUT STATUS registers.

**Figure 41. Output Status and GP\_Output Registers, Byte 2**

**Byte 2 – GP\_OUTPUT1 (Write operation) – When I2C\_Control\_Register Bit 3 =1, Bit 2=0, I<sup>2</sup>C Address = 0x0E**

GP1 (15)	GP2 (14)	GP3_ENb (13)	GP4 (12)	GP5 (11)	GP6 (10)	GP7 (9)	GP8 (8)
-------------	-------------	-----------------	-------------	-------------	-------------	------------	------------

**Byte 2 – GP\_OUTPUT1 (Read Operation) – When I2C\_Control\_Register Bit 3 =0, Bit 2=0, I<sup>2</sup>C Address = 0x0E**

GP1 (15)	GP2 (14)	GP3_ENb (13)	GP4 (12)	GP5 (11)	GP6 (10)	GP7 (9)	GP8 (8)
-------------	-------------	-----------------	-------------	-------------	-------------	------------	------------

**Byte 2 – OUTPUT\_STATUS0 (Read Operation) – When I2C\_Control\_Register Bit 3 =0, Bit 2=1, I<sup>2</sup>C Address = 0x03**

HVOUT1 (15)	HVOUT2 (14)	OUT3 (13)	OUT4 (12)	OUT5 (11)	OUT6 (10)	OUT7 (9)	OUT8 (8)
----------------	----------------	--------------	--------------	--------------	--------------	-------------	-------------

**Figure 42. Output Status and GP\_Output Registers, Byte 1**
**Byte 1 – GP\_OUTPUT2 (Write Operation) – When I2C\_Control\_Register Bit 1=1, Bit 0=0, I2C Address = 0x0F**

GP9 (7)	GP10 (6)	GP11 (5)	GP12 (4)	GP13 (3)	GP14 (2)	X (1)	X (0)
------------	-------------	-------------	-------------	-------------	-------------	----------	----------

**Byte 1 – GP\_OUTPUT2 (Read Operation) – When I2C\_Control\_Register Bit 1=0, Bit 0=0, I2C Address = 0x0F**

GP9 (7)	GP10 (6)	GP11 (5)	GP12 (4)	GP13 (3)	GP14 (2)	X (1)	X (0)
------------	-------------	-------------	-------------	-------------	-------------	----------	----------

**Byte 1 – OUTPUT\_STATUS1 (Read Operation) – When I2C\_Control\_Register Bit 1=0, Bit 0=1, I2C Address = 0x04**

OUT9 (7)	OUT10 (6)	OUT11 (5)	OUT12 (4)	OUT13 (3)	OUT14 (2)	1 (1)	1 (0)
-------------	--------------	--------------	--------------	--------------	--------------	----------	----------

### JTAG Access Method Example

This example shows various steps required to measure the voltage applied to the VMON5 of the ispPAC-POWR1014A device. These steps include transition through the TAP states shown in Figure 32. This example assumes that 5 V is applied to VMON5.

**Figure 43. VMON5 JTAG Access Example**

```

TRST  ON;
TRST  OFF;
! --- I2C Control Register
SIR   8  TDI (26);
! --- Set Bit 6 for ADC_MUX Register Write
SDR   12 TDI (040);
STATE IDLE;
! --- end I2C Control Register

! --- I2C Data Register Write ADC convert
SIR   8  TDI (25);
! --- Set ADC Attenuate
! --- Set VMON Select Bits [3:0] to VMON5
SDR   72 TDI (000000000028000000);
! --- Wait 100us for ADC conversion
RUNTEST 1000 TCK;
STATE IDLE;
! --- end I2C Data Register Write ADC Convert

! --- I2C Data Register Read
SDR   72 TDI(xxxxxxxxxxxxxxxxxxxx) TDO (xxxxxxxxxxxxxxxxxxxxxxxx);
STATE IDLE;
! --- end I2C Data Register Read
    
```

Table 13 shows the bit values of 72-bit I2C\_Data\_Register packet after POR.

**Table 13. I2C\_Data\_Register Packet Reset Values**

JTAG Byte	Equivalent I <sup>2</sup> C Register Address	Register Name	Read/Write	Description	Value After POR <sup>1</sup>
9	0x00	vmon_status0	R	VMON input status Vmon[1:4]	---- ----
8	0x01	vmon_status1	R	VMON input status Vmon[5:8]	---- ----
7	0x02	vmon_status2	R	VMON input status Vmon[9:10]	---- XXXX
2	0x03	output_status0	R	Output status HVOUT[1:2], OUT[3:8],	---- ----
1	0x04	output_status1	R	Output status OUT[9:14]	XX -- ----
3	0x06	input_status	R	Input Status IN[2:4]	X --- XXXX
6	0x07	adc_value_low	R	ADC D[0:3]	XXXX ----
5	0x08	adc_value_high	R	ADC D[4:11]	---- -- XX
4	0x09	adc_mux	R/W	ADC Mux[0:3] & Attenuator	0000 0XXX
2	0x0E	gp_output1	R/W	GPOUT[1:8]	0000 0100
1	0x0F	gp_output2	R/W	GPOUT[9:14]	0000 00XX
3	0x11	Input_value	R/W	PLD Input Register [2:4]	X 000 XXXX

1. "X" = Non-functional bit (bits read out as 1's).  
 "-" = State depends on device configuration of input status.

**Package Diagrams**

**48-Pin TQFP (Dimensions in Millimeters)**

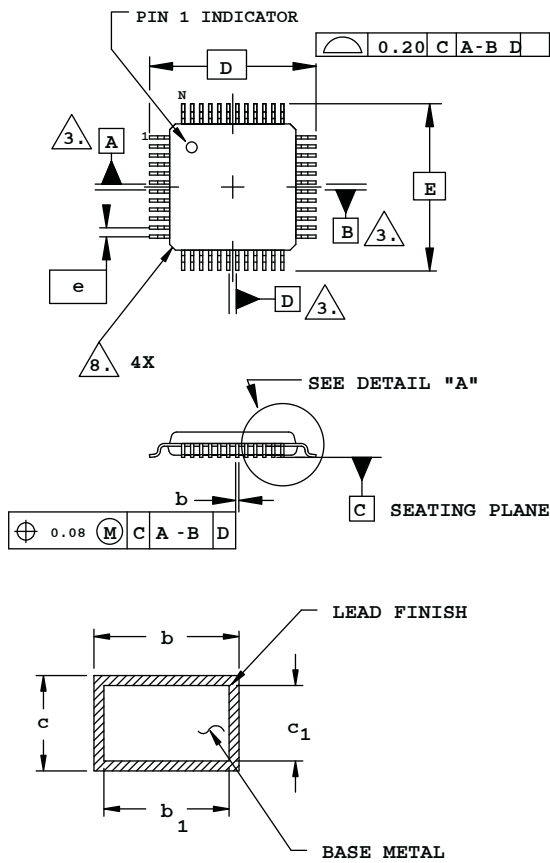

**SECTION B - B**

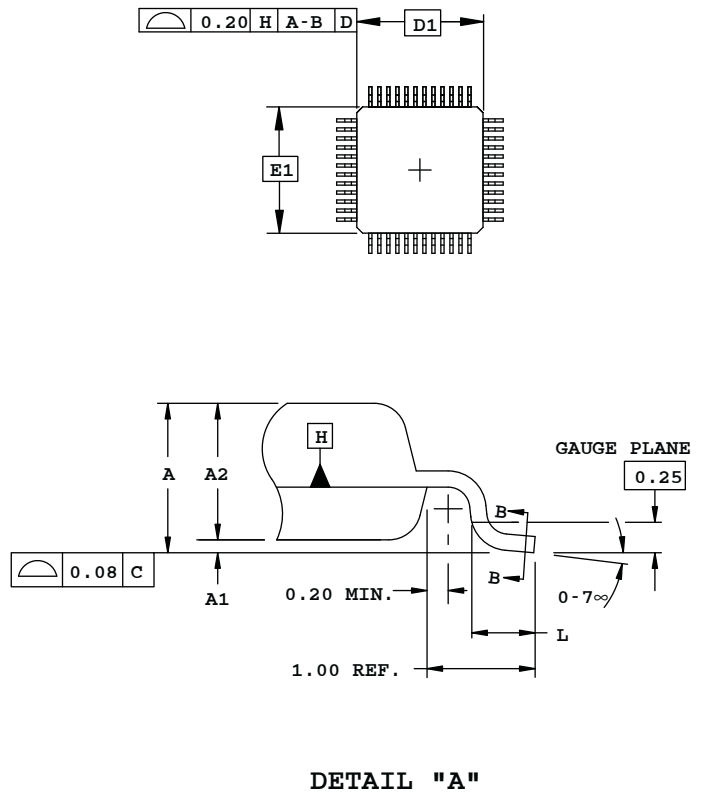

**NOTES:**

1. DIMENSIONING AND TOLERANCING PER ANSI Y14.5 - 1982.
2. ALL DIMENSIONS ARE IN MILLIMETERS.
3. DATUMS A, B AND D TO BE DETERMINED AT DATUM PLANE H.
4. DIMENSIONS D1 AND E1 DO NOT INCLUDE MOLD PROTRUSION. ALLOWABLE MOLD PROTRUSION IS 0.254 MM ON D1 AND E1 DIMENSIONS.
5. THE TOP OF PACKAGE MAY BE SMALLER THAN THE BOTTOM OF THE PACKAGE BY 0.15 MM.
6. SECTION B-B:  
THESE DIMENSIONS APPLY TO THE FLAT SECTION OF THE LEAD BETWEEN 0.10 AND 0.25 MM FROM THE LEAD TIP.
7. A1 IS DEFINED AS THE DISTANCE FROM THE SEATING PLANE TO THE LOWEST POINT ON THE PACKAGE BODY.
8. EXACT SHAPE OF EACH CORNER IS OPTIONAL.

SYMBOL	MIN.	NOM.	MAX.
A	-	-	1.60
A1	0.05	-	0.15
A2	1.35	1.40	1.45
D	9.00 BSC		
D1	7.00 BSC		
E	9.00 BSC		
E1	7.00 BSC		
L	0.45	0.60	0.75
N	48		
e	0.50 BSC		
b	0.17	0.22	0.27
b1	0.17	0.20	0.23
c	0.09	0.15	0.20
c1	0.09	0.13	0.16

## Part Number Description

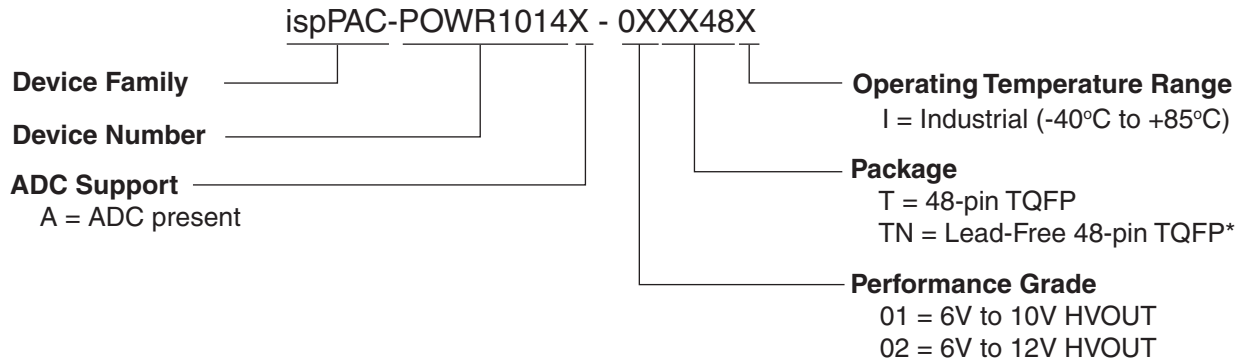

## ispPAC-POWR1014/A Ordering Information

### Conventional Packaging

Part Number	Package	Pins
ispPAC-POWR1014A-01T48I	TQFP	48
ispPAC-POWR1014-01T48I	TQFP	48
ispPAC-POWR1014A-02T48I	TQFP	48
ispPAC-POWR1014-02T48I	TQFP	48

### Lead-Free Packaging

Part Number	Package	Pins
ispPAC-POWR1014A-01TN48I	Lead-Free TQFP	48
ispPAC-POWR1014-01TN48I	Lead-Free TQFP	48
ispPAC-POWR1014A-02TN48I	Lead-Free TQFP	48
ispPAC-POWR1014-02TN48I	Lead-Free TQFP	48

**Package Options**

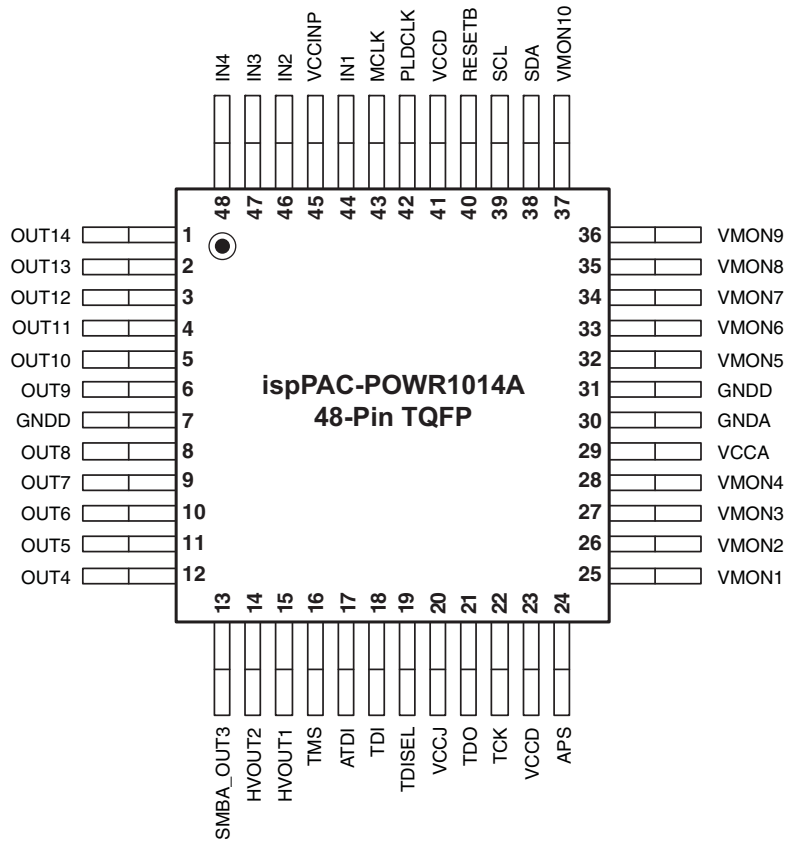

## Package Options (Cont.)

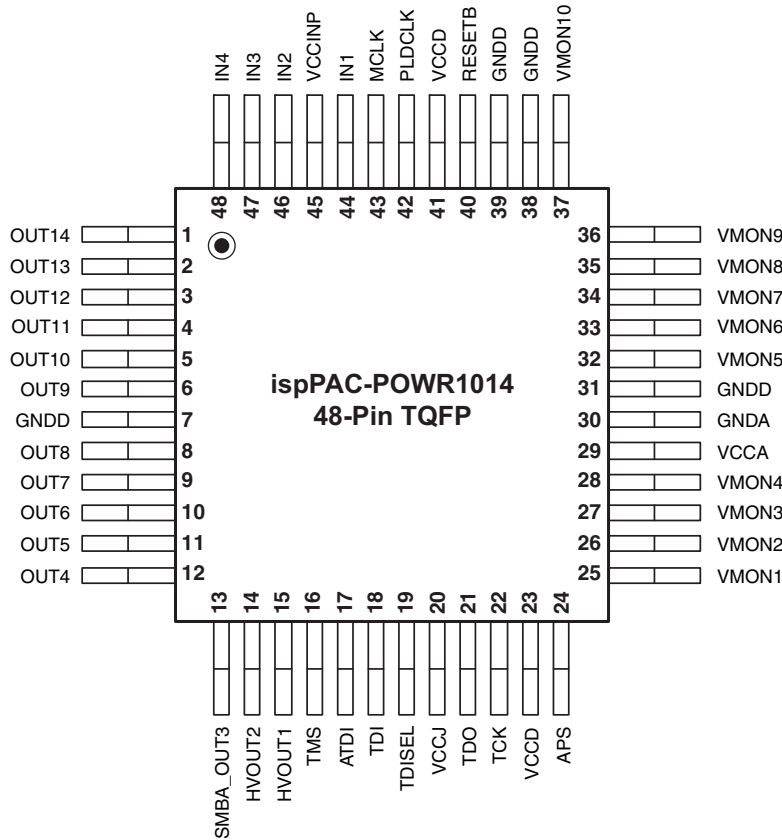

## Technical Support Assistance

Submit a technical support case via [www.latticesemi.com/techsupport](http://www.latticesemi.com/techsupport).

## Revision History

Date	Version	Change Summary
November 2015	2.2	Updated <a href="#">Pin Descriptions</a> section. Revised table footnote 7.
		Updated <a href="#">I<sup>2</sup>C/SMBUS Interface (ispPAC-POWR1014A Only)</a> section. Revised 0x08 register value after POR in Table 7, I <sup>2</sup> C Control Registers.
		Updated <a href="#">Technical Support Assistance</a> section.
March 2015	2.1	Updated I <sup>2</sup> C Port Characteristics section. Updated T <sub>HD;DAT</sub> timing to match I2C Specifications.
		Updated Package Options section. Corrected pin 19 name on package diagram.
September 2013	02.0	Renamed VCCPROG pin APS. Added ADC Typical Error below 600 mV.
		Typographical correction: OUT5/SMBA changed to OUT3/SMBA (Figure 15).
		Added the ispPAC-POWR1014/A JTAG Interconnection Configuration Diagram (Figure 27).
		Changed the ispPAC-POWR1014/A Alternate TDI Configuration Diagram figure to ispPAC-POWR1014/A Alternate Configuration Diagram (Figure 28).
		Updated Technical Support Assistance information.

Date	Version	Change Summary
February 2011	01.9	Updated document with new corporate logo.
November 2009	01.8	Added ESD Performance table.
November 2009	01.7	VCCPROG pin usage further clarified.
		Added Accessing I <sup>2</sup> C Registers Through JTAG section.
		Added product information for the ispPAC-POWR1014-02 and ispPAC-POWR1014A-02.
June 2008	01.6	Added timing diagram and timing parameters to "Power-On Reset" specifications.
		Modified PLD Architecture figure to show input registers.
		Updated I <sup>2</sup> C Control Registers table.
		V <sub>CCPROG</sub> pin usage clarification added.
August 2007	01.5	Changes to HVOUT pin specifications.
March 2007	01.4	Corrected VCCINP Voltage range from "2.25 V to 3.6 V" to "2.25 V to 5.5 V".
		Removed reference to Internal Pull-up resistor for signal line TDO.
		Corrected the Maximum Vmon Range value from 5.734V to 5.867V.
		Removed references to VPS[0:1].
October 2006	01.3	Data sheet status changed to "Final"
		Analog Specifications table, reduced Max. I <sub>CC</sub> to 20 mA.
		Tightened Input Resistor Variation to 15%.
		AC/Transient Characteristics table, tightened Internal Oscillator frequency variation down to 5%.
		Digital Specifications table, included V <sub>IL</sub> and V <sub>IH</sub> specifications for I <sup>2</sup> C interface.
May 2006	01.2	Update HVOUT I source range: 12.5μA to 100μA
		Clarify operation of ADC conversions
		Digital Specifications table, added footnotes on I <sup>2</sup> C frequency
		TAP Instructions table, clarify DISCHARGE instruction of JTAG. Added instruction descriptions for others.
March 2006	01.1	ispPAC-POWR1014/A block diagram: "SELTDI" changed to "TDISEL".
		Pin Descriptions table: "InxP" changed to "Inx", "MONx" to "VMONx", VMON upper range from "5.75 V" to "5.87 V".
		Pin Descriptions table, note 4 - clarification for un-used VMON pins to be tied to GNDD.
		Absolute Maximum Ratings table and Recommended Operating Conditions table: "VMON+" changed to VMON".
		Digital Specifications table: add note # 2 to ISINKTOTAL: "Sum of maximum current sink by all digital outputs. Reliable operation is not guaranteed if this value is exceeded."
		Typographical corrections: Vmon trip points and thresholds
		Typographical corrections: "InxP" to "Inx", "MONx" to "VMONx".
February 2006	01.0	Initial release.

## Looking for pricing, stock, or lifecycle information?

Click below to explore more details on WIN SOURCE:

- ⊖ [View ISPPAC-POWR1014-01TN48I on WIN SOURCE](#)
- ⊖ [Lattice Semiconductor Corporation Information](#)

## Optimize Your Supply Chain with WIN SOURCE Solutions

- ✓ Global Sourcing Solution
- ✓ Obsolete Management
- ✓ Cost Control Management
- ✓ Shortage Management
- ✓ Alternative Solution
- ✓ Excess Inventory Management