

ISO742x Low-Power Dual-Channel Digital Isolators

1 Features

- Highest Signaling Rate: 1 Mbps
- Low Power Consumption, Typical I_{CC} per Channel (3.3-V operation):
 - ISO7420: 1.1 mA, ISO7421: 1.5 mA
- Low Propagation Delay – 9 ns Typical
- Low Skew – 300 ps Typical
- Wide T_A Range: -40°C to 125°C (M-Grade)
- 50-kV/ μs Transient Immunity, Typical
- Over 25-Year Isolation Integrity at Rated Voltage
- Operates From 3.3-V and 5-V Supply and Logic Levels
- 3.3-V and 5-V Level Translation
- Narrow Body SOIC-8 Package
- Safety and Regulatory Approvals:
 - 4242 V_{PK} Isolation per DIN V VDE V 0884-10 and DIN EN 61010-1
 - 2500 V_{RMS} Isolation for 1 minute per UL 1577
 - CSA Component Acceptance Notice 5A, IEC 60950-1 and IEC 61010-1 Standards
 - CQC Certification per GB4943.1-2011

2 Applications

- Optocoupler Replacement in:
 - Industrial Fieldbus
 - Profibus
 - Modbus
 - DeviceNet™ Data Buses
 - Servo Control Interface
 - Motor Control
 - Power Supplies
 - Battery Packs

3 Description

The ISO7420, ISO7420M and ISO7421 provide galvanic isolation up to 2500 V_{RMS} for 1 minute per UL. These digital isolators have two isolated channels. Each isolation channel has a logic input and output buffer separated by a silicon dioxide (SiO_2) insulation barrier. Used in conjunction with isolated power supplies, these devices prevent noise currents on a data bus or other circuit from entering the local ground and interfering with or damaging sensitive circuitry. The suffix M indicates wide temperature range (-40°C to 125°C).

These devices have TTL input thresholds and require two supply voltages, 3.3 or 5 V, or any combination. All inputs are 5-V tolerant when supplied from a 3.3-V supply.

Note: The ISO7420 and ISO7421 are specified for signaling rates up to 1 Mbps. Due to their fast response time, under most cases, these devices will also transmit data with much shorter pulse widths. Designers should add external filtering to remove spurious signals with input pulse duration <20 ns if desired.

Device Information⁽¹⁾

PART NUMBER	PACKAGE	BODY SIZE (NOM)
ISO7420	SOIC (8)	4.90 mm x 3.91 mm
ISO7420M		
ISO7421		

(1) For all available packages, see the orderable addendum at the end of the data sheet.

Simplified Schematic

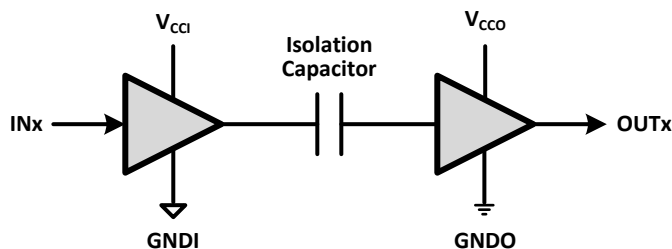

V_{CCI} and $GNDI$ are supply and ground connections respectively for the input channels.

V_{CCO} and $GNDO$ are supply and ground connections respectively for the output channels.



Table of Contents

1 Features	1	$\pm 5\%$	11
2 Applications	1	6.14 Typical Characteristics	12
3 Description	1	7 Parameter Measurement Information	13
4 Revision History	2	8 Detailed Description	14
5 Pin Configuration and Functions	6	8.1 Overview	14
6 Specifications	7	8.2 Functional Block Diagram	14
6.1 Absolute Maximum Ratings	7	8.3 Feature Description	15
6.2 ESD Ratings	7	8.4 Device Functional Modes	17
6.3 Recommended Operating Conditions	7	9 Application and Implementation	18
6.4 Thermal Information	8	9.1 Application Information	18
6.5 Electrical Characteristics: V_{CC1} and V_{CC2} at 5 V $\pm 5\%$	8	9.2 Typical Application	18
6.6 Electrical Characteristics: V_{CC1} at 5 V $\pm 5\%$, V_{CC2} at 3.3 V $\pm 5\%$	9	10 Power Supply Recommendations	20
6.7 Electrical Characteristics: V_{CC1} at 3.3 V $\pm 5\%$, V_{CC2} at 5 V $\pm 5\%$	9	11 Layout	20
6.8 Electrical Characteristics: V_{CC1} and V_{CC2} at 3.3 V $\pm 5\%$	10	11.1 Layout Guidelines	20
6.9 Power Dissipation Characteristics	10	11.2 Layout Example	20
6.10 Switching Characteristics: V_{CC1} and V_{CC2} at 5 V $\pm 5\%$	10	12 Device and Documentation Support	21
6.11 Switching Characteristics: V_{CC1} at 5 V $\pm 5\%$, V_{CC2} at 3.3 V $\pm 5\%$	10	12.1 Documentation Support	21
6.12 Switching Characteristics: V_{CC1} at 3.3 V $\pm 5\%$, V_{CC2} at 5 V $\pm 5\%$	11	12.2 Related Links	21
6.13 Switching Characteristics: V_{CC1} and V_{CC2} at 3.3 V		12.3 Community Resources	21
		12.4 Trademarks	21
		12.5 Electrostatic Discharge Caution	21
		12.6 Glossary	21
		13 Mechanical, Packaging, and Orderable Information	21

4 Revision History

NOTE: Page numbers for previous revisions may differ from page numbers in the current version.

Changes from Revision H (May 2013) to Revision I	Page
• VDE standard changed to DIN V VDE V 0884-10 (VDE V 0884-10):2006-12	1
• Added <i>Pin Configuration and Functions</i> section, <i>ESD Ratings</i> table, <i>Feature Description</i> section, <i>Device Functional Modes</i> , <i>Application and Implementation</i> section, <i>Power Supply Recommendations</i> section, <i>Layout</i> section, <i>Device and Documentation Support</i> section, and <i>Mechanical, Packaging, and Orderable Information</i> section	1

Changes from Revision G (May 2013) to Revision H	Page
• Changed Feature From: 4~242 V _{peak} Isolation To: 4242 V _{peak} Isolation	1

Changes from Revision F (January 2013) to Revision G	Page
• Changed V_{IORM} in the INSULATION CHARACTERISTICS table, Specification value From: 56~6 To: 566	15
• Changed V_{PR} in the Specification value From: 10~62 To: 1062	15
• Changed V_{IOTM} t = 60 s (qualification) Specification value From: 4~242 To: 4242	15

Changes from Revision E (June 2011) to Revision F	Page
• Changed Feature From: 242 V _{peak} Maximum Isolation-per DIN EN 60747-5-2 (VDE 0884 Part 2) - To: 4~242 V _{peak} Isolation	1
• Changed Feature From: IEC/VDE and CSA Approvals, IEC 60950-1–IEC 61010-1 End Equipment Standards Approvals, All Approvals Pending To: CSA 60950-1 and IEC 61010-1 Approved	1

• Added table Note to V_{IORM}	15
• Changed V_{IORM} in the INSULATION CHARACTERISTICS table, Specification value From: 56~0 To: 56~6.....	15
• Changed V_{PR} in the Specification value From: 10~50 To: 10~62	15
• Changed V_{IOTM} $t = 60$ s (qualification) Specification value From: 4~000 To: 4~242.....	15
• Changed the IEC 60664-1 RATINGS TABLE. Row - Basic isolation group SPECIFICATION From: III-a To: II.....	15
• Changed CTI in the PACKAGE CHARACTERISTICS table, Min value From: >175 To 400	15
• Changed the text of NOTE:	16
• Changed the REGULATORY INFORMATION table	17

Changes from Revision D (July 2010) to Revision E
Page

• Added new fifth bullet to Features and deleted text from 4-kVpeak bullet item.....	1
• Changed first paragraph in Description from: ISO7420M, ISO7421, and ISO7421M to: ISO7420M and ISO7421	1
• Changed ISO742xM in the ELEC CHAR and SWITCHING CHAR table to ISO7420M	8
• Changed ISO742xM in the ELEC CHAR and SWITCHING CHAR table to ISO7420M	9
• Changed ISO742xM in the ELEC CHAR and SWITCHING CHAR table to ISO7420M	9
• Changed ISO742xM in the ELEC CHAR and SWITCHING CHAR table to ISO7420M	10
• Changed the MAX value in the SWITCHING CHAR table 2nd row from 3.5 to 3.7 and 3rd row from 4 to 4.9.....	10
• Changed the MAX value in the 2nd SWITCHING CHAR table 2nd row from 4 to 5.6 and 3rd row from 5 to 6.3.....	10
• Changed the MAX value in the 3rd SWITCHING CHAR table 3rd row from 5 to 8.5	11
• Changed the MAX value in the 4rd SWITCHING CHAR table 3rd row from 6 to 6.8	11
• Changed Regulatory Information table last row, last column from: pending (E181974) to: E181974	17
• Changed Note 2 in Function Table from: ISO7420M, ISO7421, and ISO7421M to: ISO7420M and ISO7421	17

Changes from Revision C (March 2010) to Revision D
Page

• Updated the Features List	1
• Deleted devices ISO7420F and ISO7420FM from the data sheet.....	1
• Updated the device Description. Add paragraph - Note: The ISO7420 and ISO7421	1
• Added Tstg to the Absolute Maximum Ratings Table	7
• Updated the <i>Recommended Operating Conditions</i> table.....	7
• Updates throughout the Electrical Characteristics and Switching Characteristics tables	8
• Updated the Supply Current test conditions.....	8
• Deleted the SUPPLY CURRENT vs SIGNAL RATE (ALL CHANNELS) graphs and the EYE DIAGRAM plots	12
• Changed Figure 7	13
• Changed the V_{IORM} , V_{PR} , and V_{IOTM} unit values From: V To: Vpeak	15
• Changed Minimum internal gap MIN value From: 0.008 To: 0.014mm	15
• Changed the Barrier capacitance, input to output test conditions.....	15
• Changed the Input capacitance test conditions	15
• Changed V_I From: 5.5 V To: 5.25 V	16
• Changed From: 107mA To: 112mA.....	16
• Changed V_I From: 3.6 V To: 3.45 V	16
• Changed From: 164mA To: 171mA.....	16
• Changed Figure 10	16
• Deleted the I_{CC} equations section.....	16
• Changed the Function Table Output values for PU (Open) From: H/L To: H.....	17
• Changed Figure 11	17

Changes from Revision B (February 2010) to Revision C	Page
• Added devices ISO7420F and ISO7420FM to the data sheet	1
• Added The suffix M indicates wide temperature range (–55°C to 125°C) and the suffix F indicates output-low option in fail-safe condition. All other devices without the F suffix default to output-high in fail-safe state.	1
• Added ISO7420F and ISO7420FM to the Available Options Table	6
• Changed value from a max of 4 mA to a min of –4 mA	7
• Changed value from a min of –4 mA to a max of 4 mA	7
• Changed Electrical Characteristics Conditions.....	8
• Deleted C _i from the ELECTRICAL CHARACTERISTICS.....	8
• Added (All inputs switching with square wave clock signal for dynamic ICC measurement).....	8
• Changed ELECTRICAL CHARACTERISTICS conditions.....	9
• Added High-level output voltage ISO7420 / 7421 (3.3-V side) test condition	9
• Changed High-level output voltage min value.....	9
• Deleted C _i specification	9
• Added (All inputs switching with square wave clock signal for dynamic ICC measurement).....	9
• Changed ELECTRICAL CHARACTERISTICS conditions.....	9
• Added High-level output voltage ISO7420 / 7421 (5-V side) test condition	9
• Changed High-level output voltage min value.....	9
• Deleted C _i specification	9
• Added (All inputs switching with square wave clock signal for dynamic ICC measurement).....	9
• Changed ELECTRICAL CHARACTERISTICS conditions.....	10
• Deleted C _i specification	10
• Added (All inputs switching with square wave clock signal for dynamic ICC measurement).....	10
• Changed SWITCHING CHARACTERISTICS conditions	10
• Changed PWD parameter from duration to width	10
• Changed <i>Switching Characteristics</i> conditions.....	10
• Changed Pulse duration distortion to Pulse width distortion	10
• Changed <i>Switching Characteristics</i> conditions.....	11
• Changed SWITCHING CHARACTERISTICS conditions	11
• Changed Pulse duration distortion to Pulse width distortion	11
• Changed SWITCHING CHARACTERISTICS conditions	11
• Changed Pulse duration distortion to Pulse width distortion	11
• Changed Figure 7	13
• Added input to output and note 1 to Isolation resistance, input to output.....	15
• Changed the Isolation resistance test conditions.....	15
• Changed the Isolation resistance test conditions.....	15
• Added note 1 to Barrier capacitance, input to output.....	15
• Added Input capacitance	15
• Changed T _J = 170°C to T _J = 150°C.....	16
• Changed From: 124mA To: 107mA.....	16
• Changed T _J = 170°C to T _J = 150°C.....	16
• Changed From: 190mA To: 164mA.....	16
• Changed Figure 10	16
• Changed the Function Table Output values for PU (Open) From: H To: H/L	17
• Changed the Function Table Output values for PU (X) From: H To: H/L.....	17
• Changed the Function Table Output values for PU (X) From: H/L To: H.....	17

• Added Note (2) in the Function Table	17
• Changed Figure 11	17

Changes from Revision A (December 2009) to Revision B	Page
--	-------------

• Switching Characteristics Table, Added Note (2) - Typical specifications are measured at ideal conditions of 25°C. Max or Min specifications are measured at worst case conditions for V_{CC} and temperature.	8
---	---

Changes from Original (June 2009) to Revision A	Page
--	-------------

• Added devices ISO7420 and ISO7420M to the data sheet	1
• Added the I_{CC} equations section.....	16

5 Pin Configuration and Functions

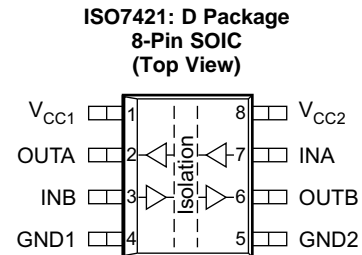
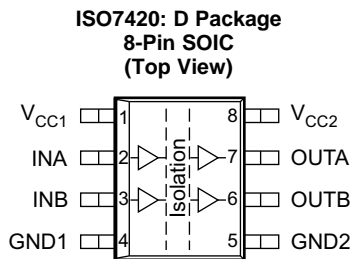

Pin Functions

NAME	PIN		I/O	DESCRIPTION
	ISO7420	ISO7421		
GND1	4	4	—	Ground connection for V_{CC1}
GND2	5	5	—	Ground connection for V_{CC2}
INA	2	7	I	Input, channel A
INB	3	3	I	Input, channel B
OUTA	7	2	O	Output, channel A
OUTB	6	6	O	Output, channel B
V_{CC1}	1	1	—	Power supply, V_{CC1}
V_{CC2}	8	8	—	Power supply, V_{CC2}

6 Specifications

6.1 Absolute Maximum Ratings

See ⁽¹⁾		MIN	MAX	UNIT
V _{CC}	Supply voltage ⁽²⁾ , V _{CC1} , V _{CC2}	-0.5	6	V
V _I	Voltage at IN, OUT	-0.5	V _{CC} + 0.5 ⁽³⁾	V
I _O	Output current	-15	15	mA
T _{J(max)}	Maximum junction temperature		150	°C
T _{stg}	Storage temperature	-65	150	°C

- (1) Stresses beyond those listed under *Absolute Maximum Ratings* may cause permanent damage to the device. These are stress ratings only and functional operation of the device at these or any other conditions beyond those indicated under *Recommended Operating Conditions* is not implied. Exposure to absolute-maximum-rated conditions for extended periods may affect device reliability.
- (2) All voltage values except differential I/O bus voltages are with respect to network ground terminal and are peak voltage values.
- (3) Maximum voltage must not exceed 6 V.

6.2 ESD Ratings

		VALUE	UNIT
V _(ESD)	Electrostatic discharge		V
	Human body model (HBM), per ANSI/ESDA/JEDEC JS-001 ⁽¹⁾	±4000	
	Field-induced charged-device model, JEDEC Standard 22, Test Method C101	±1500	
	Machine model, ANSI/ESDS5.2-1996	±200	

- (1) JEDEC document JEP155 states that 500-V HBM allows safe manufacturing with a standard ESD control process.

6.3 Recommended Operating Conditions

		MIN	NOM	MAX	UNIT	
V _{CC1} , V _{CC2}	Supply voltage - 3.3-V operation	3.15	3.3	3.45	V	
	Supply voltage - 5-V operation	4.75	5	5.25		
I _{OH}	High-level output current	-4			mA	
I _{OL}	Low-level output current			4	mA	
V _{IH}	High-level input voltage	2		5.25	V	
V _{IL}	Low-level input voltage	0		0.8	V	
1/t _{ui}	Signaling rate	0		1	Mbps	
t _{ui}	Input pulse duration	1			us	
T _J ⁽¹⁾	Junction temperature	-40		136	°C	
T _A	Ambient temperature	ISO7420, ISO7421	-40	25	105	°C
		ISO7420M	-40	25	125	

- (1) To maintain the recommended operating conditions for T_J, see the [Thermal Information](#).

6.4 Thermal Information

THERMAL METRIC ⁽¹⁾		ISO742x		UNIT
		D (SOIC)		
		8 PINS		
R _{θJA}	Junction-to-ambient thermal resistance	Low-K Board		212
		High-K Board		116.6
R _{θJC(top)}	Junction-to-case (top) thermal resistance			71.6
R _{θJB}	Junction-to-board thermal resistance			57.3
ψ _{JT}	Junction-to-top characterization parameter			28.3
ψ _{JB}	Junction-to-board characterization parameter			56.8

(1) For more information about traditional and new thermal metrics, see the *Semiconductor and IC Package Thermal Metrics* application report, [SPRA953](#).

6.5 Electrical Characteristics: V_{CC1} and V_{CC2} at 5 V ±5%

T_A = –40°C to 125°C for ISO7420M, T_A = –40°C to 105°C for ISO742x

PARAMETER	TEST CONDITIONS		MIN	TYP	MAX	UNIT
V _{OH}	High-level output voltage	I _{OH} = –4 mA; see Figure 6 .	V _{CCO} ⁽¹⁾ – 0.8	4.6		V
		I _{OH} = –20 μA; see Figure 6 .	V _{CCO} – 0.1	5		
V _{OL}	Low-level output voltage	I _{OL} = 4 mA; see Figure 6 .		0.2	0.4	V
		I _{OL} = 20 μA; see Figure 6 .		0	0.1	
V _{I(HYS)}	Input threshold voltage hysteresis			400		mV
I _{IH}	High-level input current	INx at 0 V or V _{CCI} ⁽¹⁾			10	μA
I _{IL}	Low-level input current				–10	μA
CMTI	Common-mode transient immunity	V _I = V _{CCI} or 0 V; see Figure 8 .	25	50		kV/μs
SUPPLY CURRENT (ALL INPUTS SWITCHING WITH SQUARE WAVE CLOCK SIGNAL FOR DYNAMIC ICC MEASUREMENT)						
ISO7420						
I _{CC1}	Supply current for V _{CC1}	DC to 1 Mbps	V _I = V _{CCI} or 0 V, 15 pF load	0.4	1	mA
I _{CC2}	Supply current for V _{CC2}			3	6	
ISO7421						
I _{CC1}	Supply current for V _{CC1}	DC to 1 Mbps	V _I = V _{CCI} or 0 V, 15 pF load	2	4	mA
I _{CC2}	Supply current for V _{CC2}			2	4	

(1) V_{CCI} = Input-side power supply, V_{CCO} = Output-side power supply

6.6 Electrical Characteristics: V_{CC1} at 5 V $\pm 5\%$, V_{CC2} at 3.3 V $\pm 5\%$

 $T_A = -40^\circ\text{C}$ to 125°C for ISO7420M, $T_A = -40^\circ\text{C}$ to 105°C for ISO742x

PARAMETER		TEST CONDITIONS		MIN	TYP	MAX	UNIT
V_{OH}	High-level output voltage	$I_{OH} = -4\text{ mA}$; see Figure 6.	ISO7421 (5-V side)	$V_{CCO}^{(1)} - 0.8$	4.6		V
			ISO7420 / 7421 (3.3-V side).	$V_{CCO} - 0.4$	3		
				$V_{CCO} - 0.1$	V_{CC}		
V_{OL}	Low-level output voltage	$I_{OL} = 4\text{ mA}$; see Figure 6.			0.2	0.4	V
		$I_{OL} = 20\text{ }\mu\text{A}$; see Figure 6.			0	0.1	
$V_{I(HYS)}$	Input threshold voltage hysteresis				400		mV
I_{IH}	High-level input current	INx at 0 V or $V_{CCI}^{(1)}$				10	μA
I_{IL}	Low-level input current				-10		μA
CMTI	Common-mode transient immunity	$V_I = V_{CCI}$ or 0 V; see Figure 8 .		25	40		kV/ μs
SUPPLY CURRENT (ALL INPUTS SWITCHING WITH SQUARE WAVE CLOCK SIGNAL FOR DYNAMIC ICC MEASUREMENT)							
ISO7420							
I_{CC1}	Supply current for V_{CC1}	DC to 1 Mbps	$V_I = V_{CCI}$ or 0 V, 15 pF load		0.4	1	mA
I_{CC2}	Supply current for V_{CC2}				2	4.5	
ISO7421							
I_{CC1}	Supply current for V_{CC1}	DC to 1 Mbps	$V_I = V_{CCI}$ or 0 V, 15 pF load		2	4	mA
I_{CC2}	Supply current for V_{CC2}				1.5	3.5	

(1) V_{CCI} = Input-side power supply, V_{CCO} = Output-side power supply

6.7 Electrical Characteristics: V_{CC1} at 3.3 V $\pm 5\%$, V_{CC2} at 5 V $\pm 5\%$

 $T_A = -40^\circ\text{C}$ to 125°C for ISO7420M, $T_A = -40^\circ\text{C}$ to 105°C for ISO742x

PARAMETER		TEST CONDITIONS		MIN	TYP	MAX	UNIT
V_{OH}	High-level output voltage	$I_{OH} = -4\text{ mA}$; see Figure 6.	ISO7420 / 7421 (5-V side).	$V_{CCO}^{(1)} - 0.8$	4.6		V
			ISO7421 (3.3-V side)	$V_{CCO} - 0.4$	3		
				$V_{CCO} - 0.1$	V_{CC}		
V_{OL}	Low-level output voltage	$I_{OL} = 4\text{ mA}$; see Figure 6.			0.2	0.4	V
		$I_{OL} = 20\text{ }\mu\text{A}$; see Figure 6.			0	0.1	
$V_{I(HYS)}$	Input threshold voltage hysteresis				400		mV
I_{IH}	High-level input current	INx at 0 V or $V_{CCI}^{(1)}$				10	μA
I_{IL}	Low-level input current				-10		μA
CMTI	Common-mode transient immunity	$V_I = V_{CCI}$ or 0 V; see Figure 8.		25	40		kV/ μs
SUPPLY CURRENT (ALL INPUTS SWITCHING WITH SQUARE WAVE CLOCK SIGNAL FOR DYNAMIC ICC MEASUREMENT)							
ISO7420							
I_{CC1}	Supply current for V_{CC1}	DC to 1 Mbps	$V_I = V_{CCI}$ or 0 V, 15 pF load		0.2	0.7	mA
I_{CC2}	Supply current for V_{CC2}				3	6	
ISO7421							
I_{CC1}	Supply current for V_{CC1}	DC to 1 Mbps	$V_I = V_{CCI}$ or 0 V, 15 pF load		1.5	3.5	mA
I_{CC2}	Supply current for V_{CC2}				2	4	

(1) V_{CCI} = Input-side power supply, V_{CCO} = Output-side power supply

6.8 Electrical Characteristics: V_{CC1} and V_{CC2} at 3.3 V \pm 5%

 $T_A = -40^\circ\text{C}$ to 125°C for ISO7420M, $T_A = -40^\circ\text{C}$ to 105°C for ISO742x

PARAMETER	TEST CONDITIONS	MIN	TYP	MAX	UNIT
V_{OH} High-level output voltage	$I_{OH} = -4$ mA; see Figure 6.	$V_{CCO}^{(1)} - 0.4$	3		V
	$I_{OH} = -20$ μ A; see Figure 6.	$V_{CCO} - 0.1$	3.3		
V_{OL} Low-level output voltage	$I_{OL} = 4$ mA; see Figure 6.		0.2	0.4	V
	$I_{OL} = 20$ μ A; see Figure 6.		0	0.1	
$V_{I(HYS)}$ Input threshold voltage hysteresis			400		mV
I_{IH} High-level input current	I_{Nx} at 0 V or $V_{CC1}^{(1)}$			10	μ A
I_{IL} Low-level input current			-10		μ A
CMTI Common-mode transient immunity	$V_I = V_{CC1}$ or 0 V; see Figure 8 .	25	40		kV/ μ s
SUPPLY CURRENT (ALL INPUTS SWITCHING WITH SQUARE WAVE CLOCK SIGNAL FOR DYNAMIC ICC MEASUREMENT)					
ISO7420					
I_{CC1} Supply current for V_{CC1}	DC to 1 Mbps	$V_I = V_{CC1}$ or 0 V, 15 pF load	0.2	0.7	mA
I_{CC2} Supply current for V_{CC2}			2	4.5	
ISO7421					
I_{CC1} Supply current for V_{CC1}	DC to 1 Mbps	$V_I = V_{CC1}$ or 0 V, 15 pF load	1.5	3.5	mA
I_{CC2} Supply current for V_{CC2}			1.5	3.5	

 (1) V_{CC1} = Input-side power supply, V_{CCO} = Output-side power supply

6.9 Power Dissipation Characteristics

THERMAL METRIC		ISO742x	UNIT
		D (SOIC)	
		8 PINS	
P_D Device power dissipation	$V_{CC1} = V_{CC2} = 5.25$ V, $T_J = 150^\circ\text{C}$, $C_L = 15$ pF Input a 1-Mbps 50% duty-cycle square wave	55	mW

6.10 Switching Characteristics: V_{CC1} and V_{CC2} at 5 V \pm 5%

 $T_A = -40^\circ\text{C}$ to 125°C for ISO7420M, $T_A = -40^\circ\text{C}$ to 105°C for ISO742x

PARAMETER	TEST CONDITIONS	MIN	TYP	MAX	UNIT
t_{PLH} , t_{PHL} Propagation delay time	See Figure 6.		9	14	ns
PWD ⁽¹⁾ Pulse width distortion $ t_{PHL} - t_{PLH} $			0.3	3.7	ns
$t_{sk(pp)}$ Part-to-part skew time				4.9	ns
$t_{sk(o)}$ Channel-to-channel output skew time				3.6	ns
t_r Output signal rise time	See Figure 6.		1		ns
t_f Output signal fall time			1		ns
t_{fs} Fail-safe output delay time from input power loss	See Figure 7.		6		μ s

(1) Also known as pulse skew.

6.11 Switching Characteristics: V_{CC1} at 5 V \pm 5%, V_{CC2} at 3.3 V \pm 5%

 $T_A = -40^\circ\text{C}$ to 125°C for ISO7420M, $T_A = -40^\circ\text{C}$ to 105°C for ISO742x

PARAMETER	TEST CONDITIONS	MIN	TYP	MAX	UNIT
t_{PLH} , t_{PHL} Propagation delay time	See Figure 6.		10	17	ns
PWD ⁽¹⁾ Pulse width distortion $ t_{PHL} - t_{PLH} $			0.5	5.6	ns
$t_{sk(pp)}$ Part-to-part skew time				6.3	ns
$t_{sk(o)}$ Channel-to-channel output skew time				4	ns
t_r Output signal rise time	See Figure 6.		2		ns

(1) Also known as pulse skew.

Switching Characteristics: V_{CC1} at 5 V $\pm 5\%$, V_{CC2} at 3.3 V $\pm 5\%$ (continued)
 $T_A = -40^\circ\text{C}$ to 125°C for ISO7420M, $T_A = -40^\circ\text{C}$ to 105°C for ISO742x

PARAMETER		TEST CONDITIONS	MIN	TYP	MAX	UNIT
t_f	Output signal fall time			2		ns
t_{fs}	Fail-safe output delay time from input power loss	See Figure 7 .		6		μs

6.12 Switching Characteristics: V_{CC1} at 3.3 V $\pm 5\%$, V_{CC2} at 5 V $\pm 5\%$
 $T_A = -40^\circ\text{C}$ to 125°C for ISO7420M, $T_A = -40^\circ\text{C}$ to 105°C for ISO742x

PARAMETER		TEST CONDITIONS	MIN	TYP	MAX	UNIT
t_{PLH} , t_{PHL}	Propagation delay time	See Figure 6 .		10	17	ns
PWD ⁽¹⁾	Pulse width distortion $ t_{PHL} - t_{PLH} $			0.5	4	ns
$t_{sk(pp)}$	Part-to-part skew time				8.5	ns
$t_{sk(o)}$	Channel-to-channel output skew time				4	ns
t_r	Output signal rise time	See Figure 6 .		2		ns
t_f	Output signal fall time			2		ns
t_{fs}	Fail-safe output delay time from input power loss	See Figure 7 .		6		μs

(1) Also known as pulse skew.

6.13 Switching Characteristics: V_{CC1} and V_{CC2} at 3.3 V $\pm 5\%$
 $T_A = -40^\circ\text{C}$ to 125°C for ISO7420M, $T_A = -40^\circ\text{C}$ to 105°C for ISO742x

PARAMETER		TEST CONDITIONS	MIN	TYP	MAX	UNIT
t_{PLH} , t_{PHL}	Propagation delay time	See Figure 6 .		12	20	ns
PWD ⁽¹⁾	Pulse width distortion $ t_{PHL} - t_{PLH} $			1	5	ns
$t_{sk(pp)}$	Part-to-part skew time				6.8	ns
$t_{sk(o)}$	Channel-to-channel output skew time				5.5	ns
t_r	Output signal rise time	See Figure 6 .		2		ns
t_f	Output signal fall time			2		ns
t_{fs}	Fail-safe output delay time from input power loss	See Figure 7 .		6		μs

(1) Also known as pulse skew.

6.14 Typical Characteristics

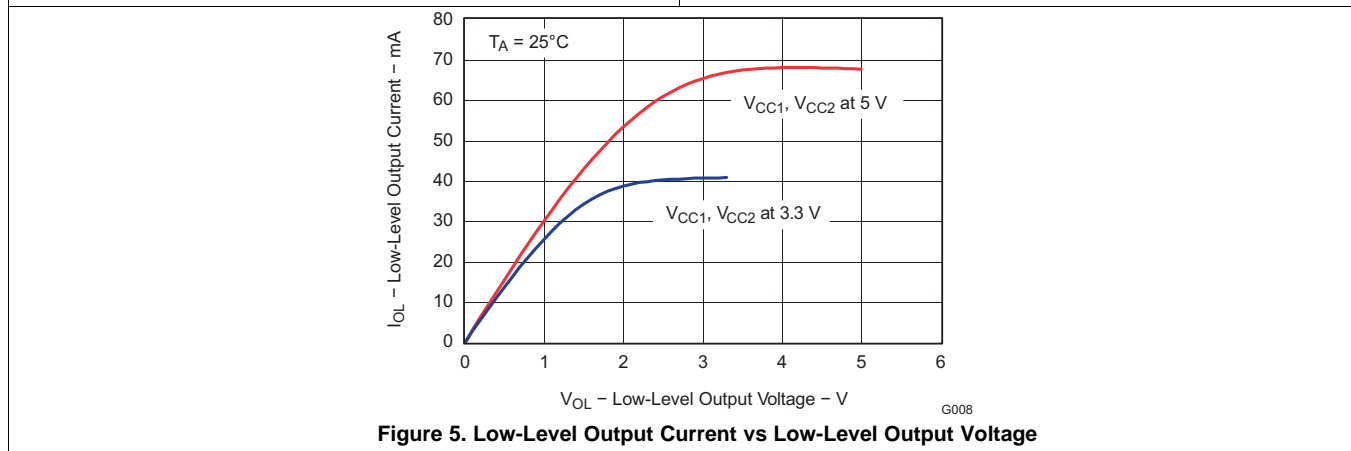
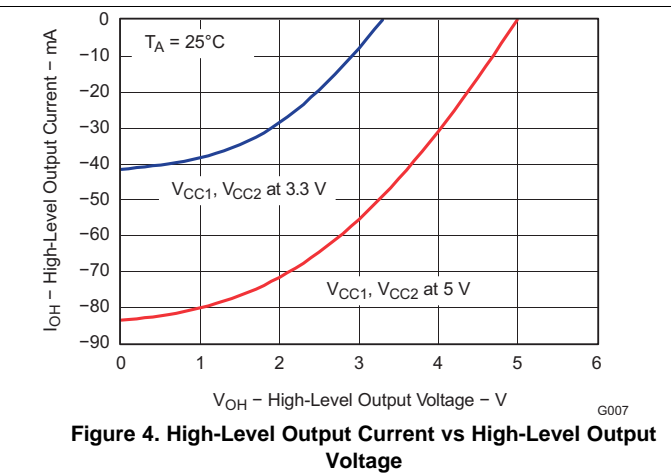
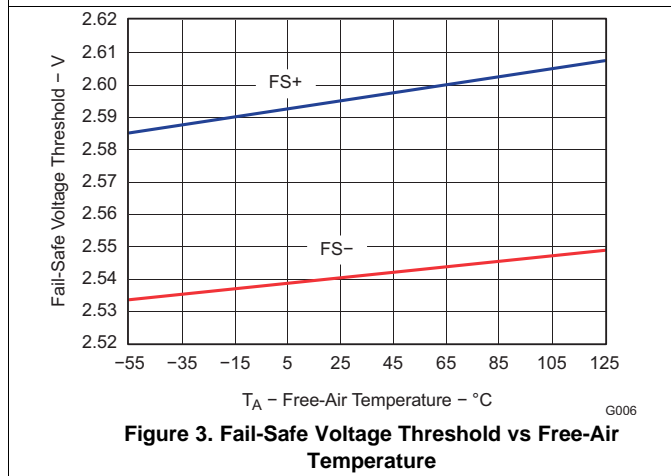
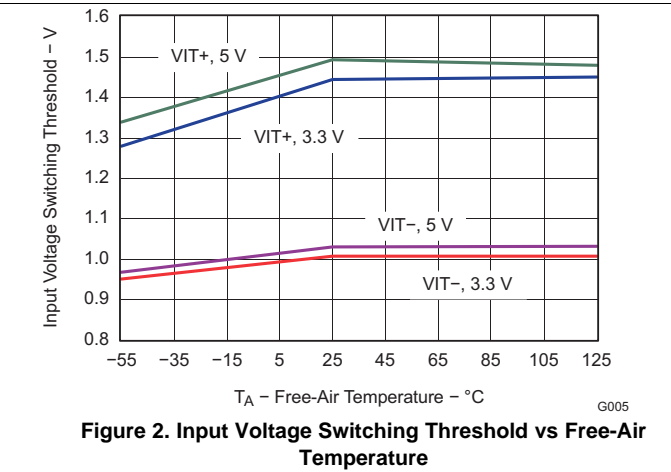
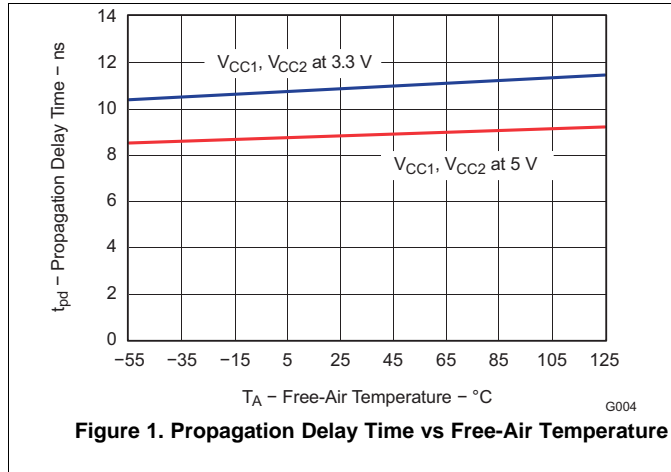

7 Parameter Measurement Information

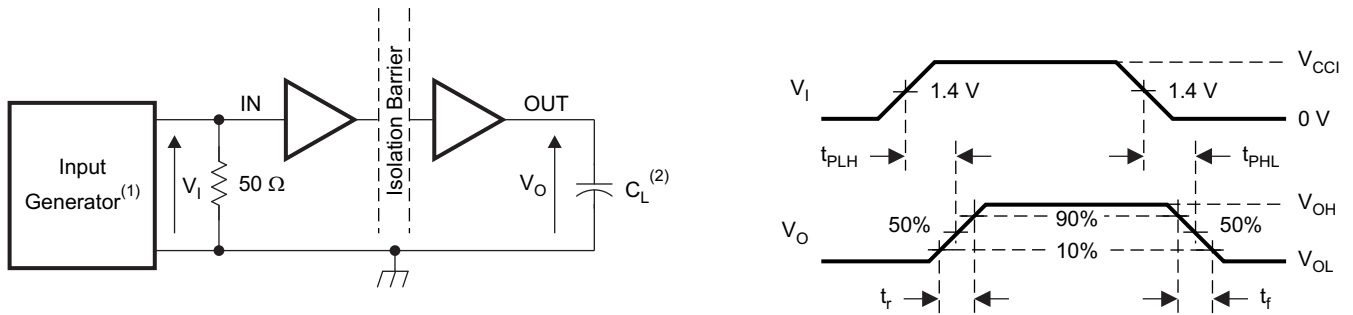

- (1) The input pulse is supplied by a generator having the following characteristics: PRR \leq 50 kHz, 50% duty cycle, $t_r \leq$ 3 ns, $t_f \leq$ 3 ns, $Z_o = 50 \Omega$. At the input, a 50- Ω resistor is required to terminate the Input Generator signal. It is not needed in actual application.
- (2) $C_L = 15$ pF and includes instrumentation and fixture capacitance within $\pm 20\%$.

Figure 6. Switching Characteristic Test Circuit and Voltage Waveforms

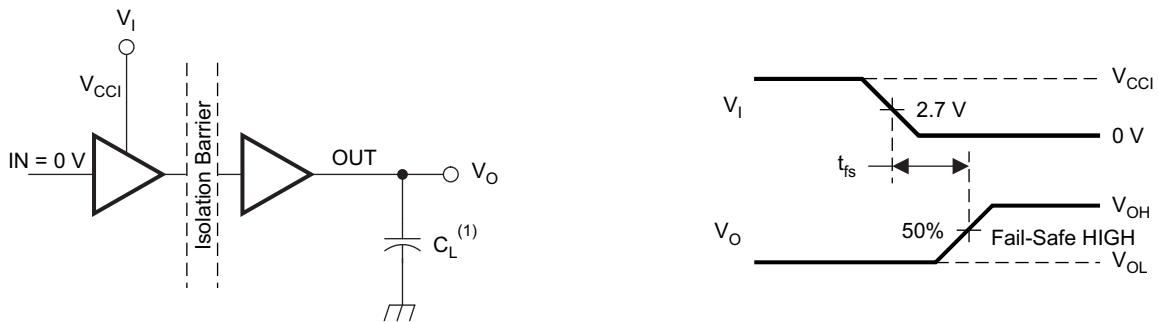

- (1) $C_L = 15$ pF $\pm 20\%$ includes instrumentation and fixture capacitance.

Figure 7. Fail-Safe Output Delay-Time Test Circuit and Voltage Waveforms

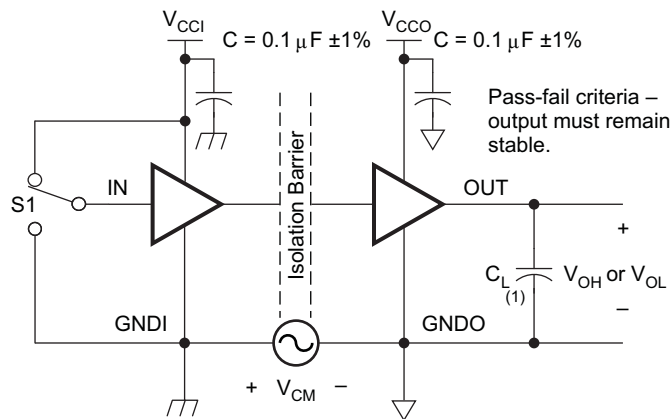

- (1) $C_L = 15$ pF and includes instrumentation and fixture capacitance within $\pm 20\%$.

Figure 8. Common-Mode Transient Immunity Test Circuit

8 Detailed Description

8.1 Overview

The isolator in [Figure 9](#) is based on a capacitive isolation barrier technique. The I/O channel of the device consists of two internal data channels, a high-frequency channel (HF) with a bandwidth from 100 kbps up to 1 Mbps, and a low-frequency channel (LF) covering the range from 100 kbps down to DC. In principle, a single-ended input signal entering the HF-channel is split into a differential signal via the inverter gate at the input. The following capacitor-resistor networks differentiate the signal into transients, which then are converted into differential pulses by two comparators. The comparator outputs drive a NOR-gate flip-flop whose output feeds an output multiplexer. A decision logic (DCL) at the driving output of the flip-flop measures the durations between signal transients. If the duration between two consecutive transients exceeds a certain time limit, (as in the case of a low-frequency signal), the DCL forces the output-multiplexer to switch from the high- to the low-frequency channel.

Because low-frequency input signals require the internal capacitors to assume prohibitively large values, these signals are pulse-width modulated (PWM) with the carrier frequency of an internal oscillator, thus creating a sufficiently high frequency signal, capable of passing the capacitive barrier. As the input is modulated, a low-pass filter (LPF) is needed to remove the high-frequency carrier from the actual data before passing it on to the output multiplexer.

8.2 Functional Block Diagram

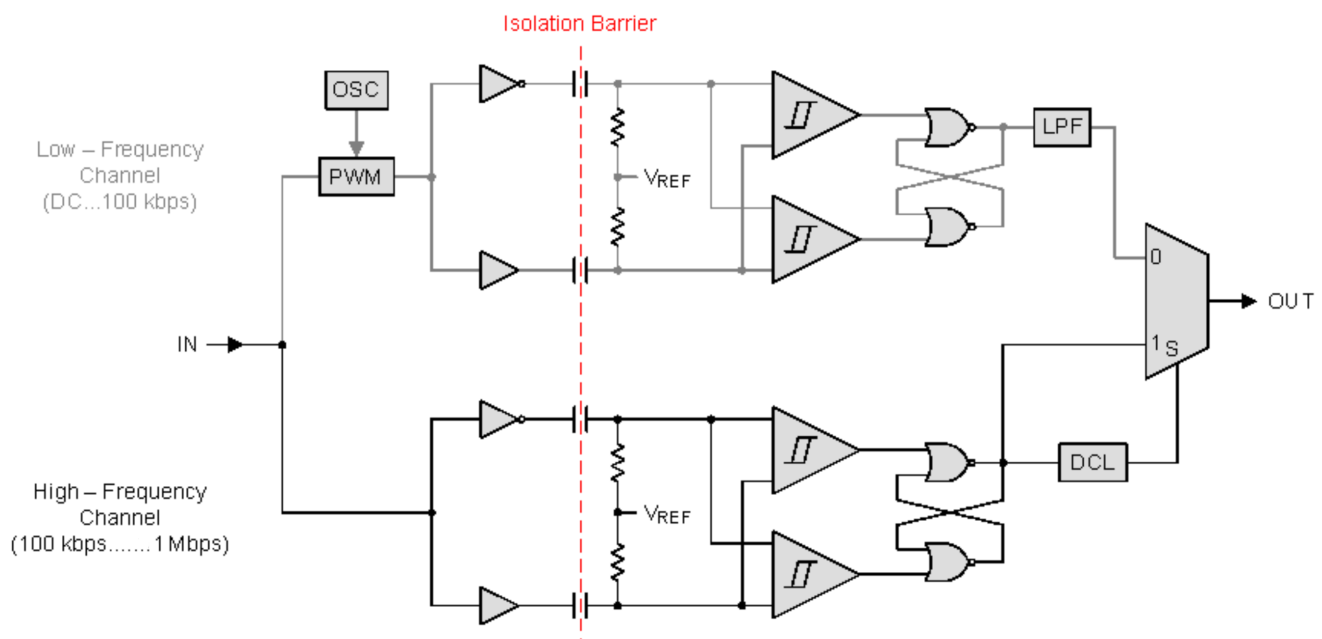

Figure 9. Conceptual Block Diagram of a Digital Capacitive Isolator

8.3 Feature Description

8.3.1 Insulation Characteristics

over recommended operating conditions (unless otherwise noted)

PARAMETER ⁽¹⁾		TEST CONDITIONS	SPECIFICATION	UNIT
DIN V VDE V 0884-10 (VDE V 0884-10):2006-12				
V _{IORM}	Maximum working insulation voltage		566	V _{PK}
V _{PR}	Input-to-output test voltage	t = 1 s (100% production), partial discharge 5 pC	1062	V _{PK}
V _{IOTM}	Transient overvoltage	t = 60 s (qualification)	4242	V _{PK}
		t = 1 s (100% production)		
R _S	Insulation resistance	V _{IO} = 500 V at T _S	>10 ⁹	Ω
	Pollution degree		2	
UL 1577				
V _{ISO}	Isolation voltage per UL	V _{TEST} = V _{ISO} = 2500 V _{RMS} , t = 60 s (qualification) V _{TEST} = 1.2 x V _{ISO} = 3000 V _{RMS} , t = 1 s (100% production)	2500	V _{RMS}

(1) Climatic Classification 40/125/21

Table 1. IEC 60664-1 Ratings Table

PARAMETER	TEST CONDITIONS	SPECIFICATION
Material group		II
Installation classification	Rated mains voltage ≤ 150 V _{RMS}	I–IV
	Rated mains voltage ≤ 300 V _{RMS}	I–III

8.3.2 Package Characteristics

over recommended operating conditions (unless otherwise noted)

PARAMETER		TEST CONDITIONS	MIN	TYP	MAX	UNIT
L(I01)	Minimum air gap (clearance)	Shortest terminal-to-terminal distance through air	4			mm
L(I02)	Minimum external tracking (creepage)	Shortest terminal-to-terminal distance across the package surface	4			mm
CTI	Tracking resistance (comparative tracking index)	DIN EN 60112 (VDE 0303-11); IEC 60112	>400			V
DTI	Distance through the insulation	Minimum internal gap (internal clearance)	0.014			mm
R _{IO}	Isolation resistance, input to output ⁽¹⁾	V _{IO} = 500 V, T _A = 25°C	>10 ¹²			Ω
		V _{IO} = 500 V, 100°C ≤ T _A ≤ max	>10 ¹¹			Ω
C _{IO}	Barrier capacitance, input to output ⁽¹⁾	V _{IO} = 0.4 sin(2πft), f = 1 MHz		1		pF
C _I	Input capacitance ⁽²⁾	V _I = V _{CC} /2 + 0.4 sin(2πft), f = 1 MHz, V _{CC} = 5 V		1		pF

(1) All pins on each side of the barrier tied together creating a two-terminal device.

(2) Measured from input pin to ground.

NOTE

Creepage and clearance requirements should be applied according to the specific equipment isolation standards of an application. Care should be taken to maintain the creepage and clearance distance of a board design to ensure that the mounting pads of the isolator on the printed-circuit board do not reduce this distance.

Creepage and clearance on a printed-circuit board become equal in certain cases. Techniques such as inserting grooves and/or ribs on a printed circuit board are used to help increase these specifications.

8.3.3 Safety Limiting Values

Safety limiting intends to prevent potential damage to the isolation barrier upon failure of input or output circuitry. A failure of the I/O can allow low resistance to ground or the supply and, without current limiting, dissipate sufficient power to overheat the die and damage the isolation barrier, potentially leading to secondary system failures.

PARAMETER		TEST CONDITIONS	MIN	TYP	MAX	UNIT
I _S	Safety input, output, or supply current	$\theta_{JA} = 212^{\circ}\text{C}/\text{W}, V_I = 5.25 \text{ V}, T_J = 150^{\circ}\text{C}, T_A = 25^{\circ}\text{C}$			112	mA
		$\theta_{JA} = 212^{\circ}\text{C}/\text{W}, V_I = 3.45 \text{ V}, T_J = 150^{\circ}\text{C}, T_A = 25^{\circ}\text{C}$			171	
T _S	Maximum safety temperature				150	°C

The safety-limiting constraint is the absolute-maximum junction temperature specified in the [Absolute Maximum Ratings](#) table. The power dissipation and junction-to-air thermal impedance of the device installed in the application hardware determines the junction temperature. The assumed junction-to-air thermal resistance in the [Thermal Information](#) table is that of a device installed in the JESD51-3, Low-Effective-Thermal-Conductivity Test Board for Leaded Surface-Mount Packages and is conservative. The power is the recommended maximum input voltage times the current. The junction temperature is then the ambient temperature plus the power times the junction-to-air thermal resistance.

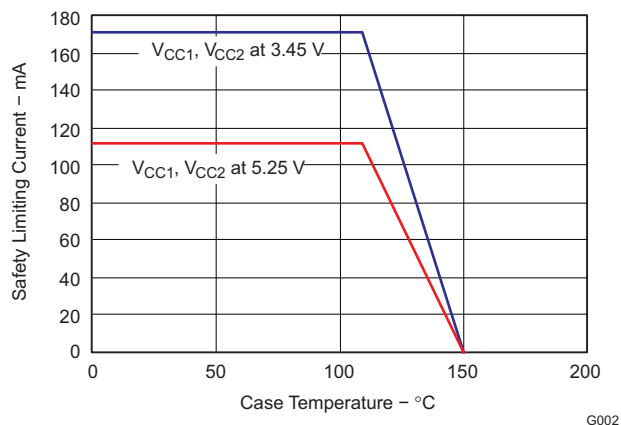

Figure 10. θ_{JC} Thermal Derating Curve per VDE

8.3.4 Regulatory Information

VDE	CSA	UL	CQC
Certified according to DIN V VDE V 0884-10 (VDE V 0884-10):2006-12 and DIN EN 61010-1 (VDE 0411-1): 2011-07	Approved under CSA Component Acceptance Notice #5A	Recognized under UL1577 Component Recognition Program ⁽¹⁾	Certified according to GB4943.1-2011
Basic Insulation Maximum Transient Overvoltage, 4242 V _{PK} Maximum Working Voltage, 566 V _{PK}	Basic insulation per CSA 60950-1-07 and IEC 60950-1 (2nd Ed), 390 VRMS maximum working voltage	Single Protection, 2500 V _{RMS}	Basic Insulation, Altitude ≤ 5000 m, Tropical Climate, 250 V _{RMS} maximum working voltage
Certificate number: 40016131	Master contract number: 220991	File number: E181974	Certificate number: CQC14001109540

(1) Production tested ≥ 3000 V_{RMS} for 1 second in accordance with UL 1577.

8.4 Device Functional Modes

Table 2. Function Table⁽¹⁾

VCCI	VCCO	INPUT INA, INB	OUTPUT OUTA, OUTB
PU	PU	H	H
		L	L
		Open	H ⁽²⁾
PD	PU	X	H ⁽²⁾
X	PD	X	Undetermined

- (1) V_{CCI} = Input-side power supply; V_{CCO} = Output-side power supply; PU = Powered up (V_{CC} ≥ 3.15 V); PD = Powered down (V_{CC} ≤ 2.1 V); X = Irrelevant; H = High level; L = Low level
- (2) In fail-safe condition, output defaults to high level.

8.4.1 Device I/O Schematics

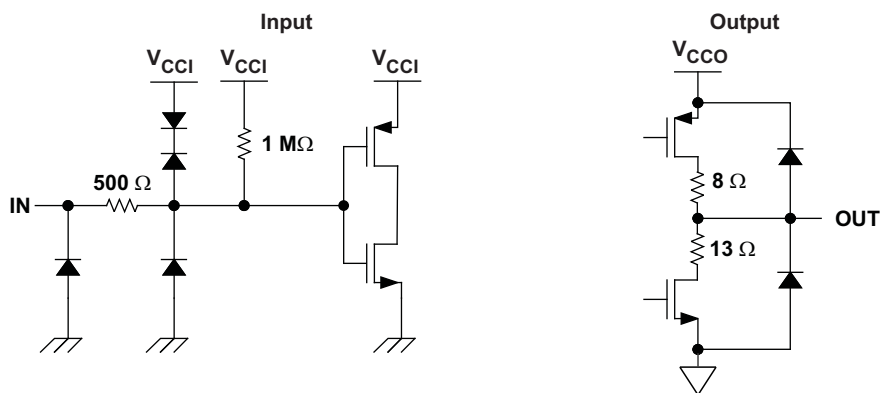

Figure 11. Device I/O Schematics

9 Application and Implementation

NOTE

Information in the following applications sections is not part of the TI component specification, and TI does not warrant its accuracy or completeness. TI's customers are responsible for determining suitability of components for their purposes. Customers should validate and test their design implementation to confirm system functionality.

9.1 Application Information

ISO742x utilize single-ended TTL-logic switching technology. Its supply voltage range is from 3.15 V to 5.25 V for both supplies, V_{CC1} and V_{CC2} . When designing with digital isolators, it is important to keep in mind that due to the single-ended design structure, digital isolators do not conform to any specific interface standard and are only intended for isolating single-ended CMOS or TTL digital signal lines. The isolator is typically placed between the data controller (i.e. μC or UART), and a data converter or a line transceiver, regardless of the interface type or standard.

9.2 Typical Application

ISO7421 can be used with Texas Instruments' mixed signal micro-controller, digital-to-analog converter, transformer driver, and voltage regulator to create an isolated 4-20 mA current loop.

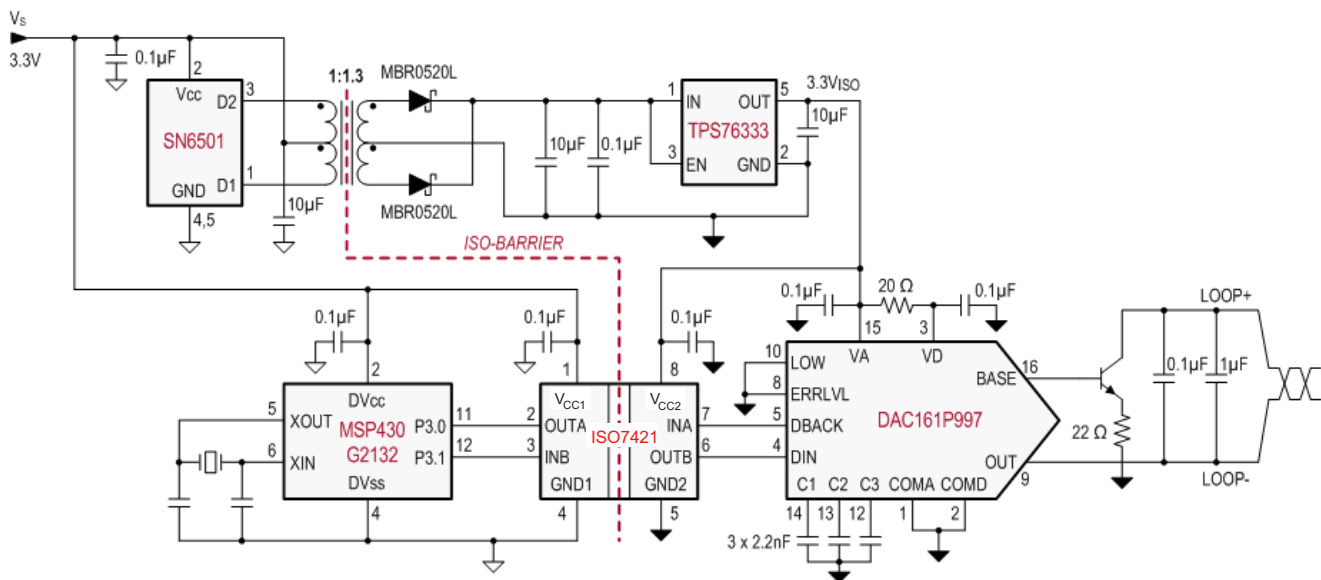

Figure 12. Isolated 4-20 mA Current Loop

9.2.1 Design Requirements

Unlike optocouplers, which require external components to improve performance, provide bias, or limit current, the ISO742x only require two external bypass capacitors to operate.

Typical Application (continued)

9.2.2 Detailed Design Procedure

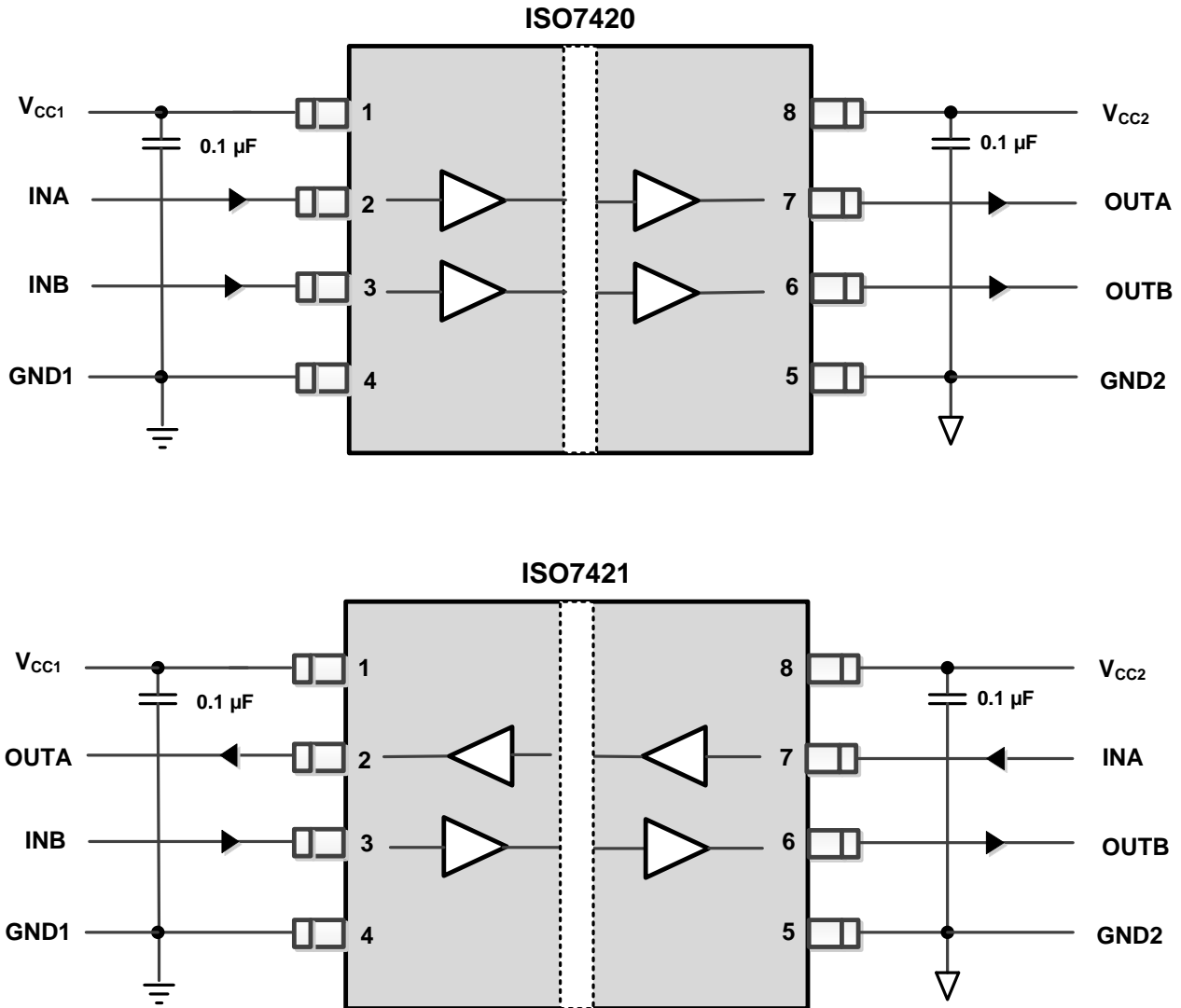

Figure 13. Typical ISO7420 and ISO7421 Circuit Hookup

9.2.3 Application Curve

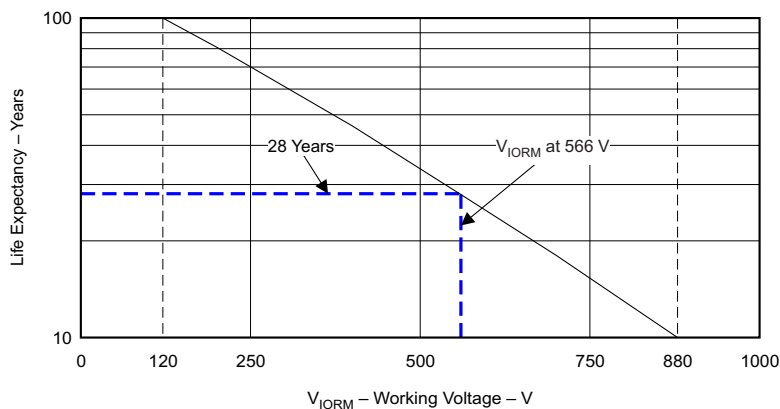

Figure 14. Life Expectancy vs Working Voltage

10 Power Supply Recommendations

To ensure reliable operation at all data rates and supply voltages, a 0.1 μF bypass capacitor is recommended at input and output supply pins (V_{CC1} and V_{CC2}). The capacitors should be placed as close to the supply pins as possible. If only a single primary-side power supply is available in an application, isolated power can be generated for the secondary-side with the help of a transformer driver such as Texas Instruments' [SN6501](#). For such applications, detailed power supply design and transformer selection recommendations are available in [SN6501](#) datasheet ([SLLSEA0](#)).

11 Layout

11.1 Layout Guidelines

A minimum of four layers is required to accomplish a low EMI PCB design (see [Figure 15](#)). Layer stacking should be in the following order (top-to-bottom): high-speed signal layer, ground plane, power plane and low-frequency signal layer.

- Routing the high-speed traces on the top layer avoids the use of vias (and the introduction of their inductances) and allows for clean interconnects between the isolator and the transmitter and receiver circuits of the data link.
- Placing a solid ground plane next to the high-speed signal layer establishes controlled impedance for transmission line interconnects and provides an excellent low-inductance path for the return current flow.
- Placing the power plane next to the ground plane creates additional high-frequency bypass capacitance of approximately 100pF/in².
- Routing the slower speed control signals on the bottom layer allows for greater flexibility as these signal links usually have margin to tolerate discontinuities such as vias.

If an additional supply voltage plane or signal layer is needed, add a second power / ground plane system to the stack to keep it symmetrical. This makes the stack mechanically stable and prevents it from warping. Also the power and ground plane of each power system can be placed closer together, thus increasing the high-frequency bypass capacitance significantly.

For detailed layout recommendations, see Application Note *Digital Isolator Design Guide*, [SLLA284](#).

11.1.1 PCB Material

For digital circuit boards operating below 150 Mbps, (or rise and fall times higher than 1 ns), and trace lengths of up to 10 inches, use standard FR-4 epoxy-glass as PCB material. FR-4 (Flame Retardant 4) meets the requirements of Underwriters Laboratories UL94-V0, and is preferred over cheaper alternatives due to its lower dielectric losses at high frequencies, less moisture absorption, greater strength and stiffness, and its self-extinguishing flammability-characteristics.

11.2 Layout Example

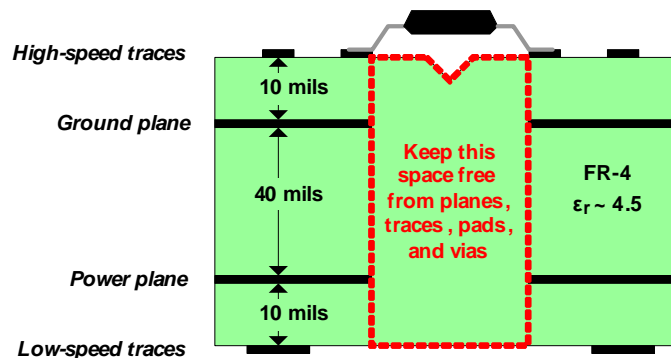

Figure 15. Recommended Layer Stack

12 Device and Documentation Support

12.1 Documentation Support

12.1.1 Related Documentation

For related documentation, see the following:

- *SN6501 Transformer Driver for Isolated Power Supplies*, [SLLSEA0](#)
- *Isolation Glossary*, [SLLA353](#)
- *Digital Isolator Design Guide*, [SLLA284](#)

12.2 Related Links

The table below lists quick access links. Categories include technical documents, support and community resources, tools and software, and quick access to sample or buy.

Table 3. Related Links

PARTS	PRODUCT FOLDER	SAMPLE & BUY	TECHNICAL DOCUMENTS	TOOLS & SOFTWARE	SUPPORT & COMMUNITY
ISO7420	Click here	Click here	Click here	Click here	Click here
ISO7420M	Click here	Click here	Click here	Click here	Click here
ISO7421	Click here	Click here	Click here	Click here	Click here
ISO7421M	Click here	Click here	Click here	Click here	Click here

12.3 Community Resources

The following links connect to TI community resources. Linked contents are provided "AS IS" by the respective contributors. They do not constitute TI specifications and do not necessarily reflect TI's views; see TI's [Terms of Use](#).

TI E2E™ Online Community *TI's Engineer-to-Engineer (E2E) Community*. Created to foster collaboration among engineers. At e2e.ti.com, you can ask questions, share knowledge, explore ideas and help solve problems with fellow engineers.

Design Support *TI's Design Support* Quickly find helpful E2E forums along with design support tools and contact information for technical support.

12.4 Trademarks

DeviceNet, E2E are trademarks of Texas Instruments.
 All other trademarks are the property of their respective owners.

12.5 Electrostatic Discharge Caution



These devices have limited built-in ESD protection. The leads should be shorted together or the device placed in conductive foam during storage or handling to prevent electrostatic damage to the MOS gates.

12.6 Glossary

[SLYZ022](#) — *TI Glossary*.

This glossary lists and explains terms, acronyms, and definitions.

13 Mechanical, Packaging, and Orderable Information

The following pages include mechanical, packaging, and orderable information. This information is the most current data available for the designated devices. This data is subject to change without notice and revision of this document. For browser-based versions of this data sheet, refer to the left-hand navigation.

PACKAGING INFORMATION

Orderable Device	Status (1)	Package Type	Package Drawing	Pins	Package Qty	Eco Plan (2)	Lead finish/ Ball material (6)	MSL Peak Temp (3)	Op Temp (°C)	Device Marking (4/5)	Samples
ISO7420D	ACTIVE	SOIC	D	8	75	RoHS & Green	NIPDAU	Level-1-260C-UNLIM	-40 to 125	IS7420	Samples
ISO7420DR	ACTIVE	SOIC	D	8	2500	RoHS & Green	NIPDAU	Level-1-260C-UNLIM	-40 to 125	IS7420	Samples
ISO7420MD	ACTIVE	SOIC	D	8	75	RoHS & Green	NIPDAU	Level-1-260C-UNLIM	-40 to 125	I7420M	Samples
ISO7420MDR	ACTIVE	SOIC	D	8	2500	RoHS & Green	NIPDAU	Level-1-260C-UNLIM	-40 to 125	I7420M	Samples
ISO7421D	ACTIVE	SOIC	D	8	75	RoHS & Green	NIPDAU	Level-1-260C-UNLIM	-40 to 125	IS7421	Samples
ISO7421DR	ACTIVE	SOIC	D	8	2500	RoHS & Green	NIPDAU	Level-1-260C-UNLIM	-40 to 125	IS7421	Samples

(1) The marketing status values are defined as follows:

ACTIVE: Product device recommended for new designs.

LIFEBUY: TI has announced that the device will be discontinued, and a lifetime-buy period is in effect.

NRND: Not recommended for new designs. Device is in production to support existing customers, but TI does not recommend using this part in a new design.

PREVIEW: Device has been announced but is not in production. Samples may or may not be available.

OBSOLETE: TI has discontinued the production of the device.

(2) **RoHS:** TI defines "RoHS" to mean semiconductor products that are compliant with the current EU RoHS requirements for all 10 RoHS substances, including the requirement that RoHS substance do not exceed 0.1% by weight in homogeneous materials. Where designed to be soldered at high temperatures, "RoHS" products are suitable for use in specified lead-free processes. TI may reference these types of products as "Pb-Free".

RoHS Exempt: TI defines "RoHS Exempt" to mean products that contain lead but are compliant with EU RoHS pursuant to a specific EU RoHS exemption.

Green: TI defines "Green" to mean the content of Chlorine (Cl) and Bromine (Br) based flame retardants meet JS709B low halogen requirements of <=1000ppm threshold. Antimony trioxide based flame retardants must also meet the <=1000ppm threshold requirement.

(3) MSL, Peak Temp. - The Moisture Sensitivity Level rating according to the JEDEC industry standard classifications, and peak solder temperature.

(4) There may be additional marking, which relates to the logo, the lot trace code information, or the environmental category on the device.

(5) Multiple Device Markings will be inside parentheses. Only one Device Marking contained in parentheses and separated by a "~" will appear on a device. If a line is indented then it is a continuation of the previous line and the two combined represent the entire Device Marking for that device.

(6) Lead finish/Ball material - Orderable Devices may have multiple material finish options. Finish options are separated by a vertical ruled line. Lead finish/Ball material values may wrap to two lines if the finish value exceeds the maximum column width.

Important Information and Disclaimer: The information provided on this page represents TI's knowledge and belief as of the date that it is provided. TI bases its knowledge and belief on information provided by third parties, and makes no representation or warranty as to the accuracy of such information. Efforts are underway to better integrate information from third parties. TI has taken and continues to take reasonable steps to provide representative and accurate information but may not have conducted destructive testing or chemical analysis on incoming materials and chemicals. TI and TI suppliers consider certain information to be proprietary, and thus CAS numbers and other limited information may not be available for release.

In no event shall TI's liability arising out of such information exceed the total purchase price of the TI part(s) at issue in this document sold by TI to Customer on an annual basis.

OTHER QUALIFIED VERSIONS OF ISO7421 :

- Enhanced Product: [ISO7421-EP](#)

NOTE: Qualified Version Definitions:

- Enhanced Product - Supports Defense, Aerospace and Medical Applications

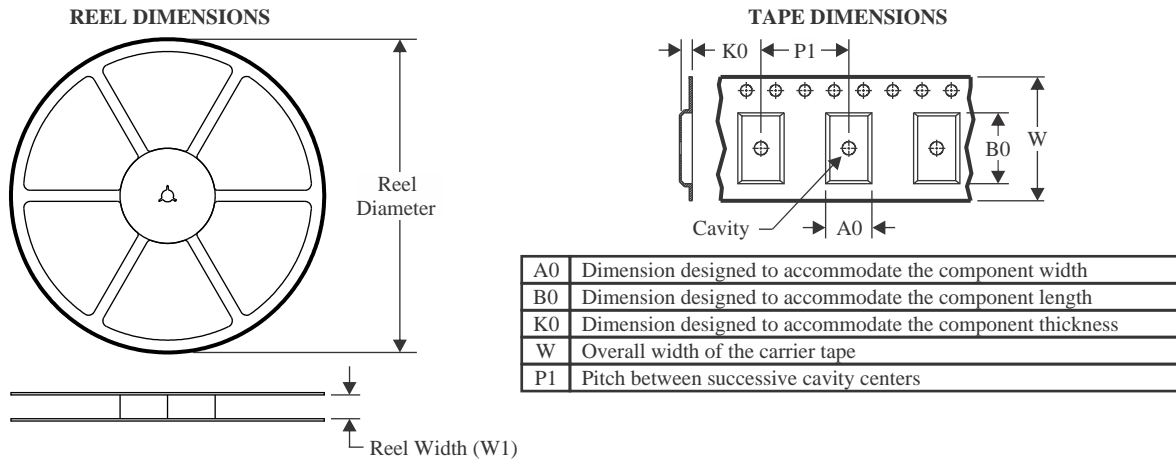
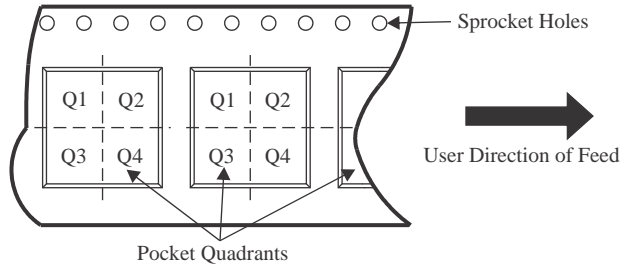
TAPE AND REEL INFORMATION

QUADRANT ASSIGNMENTS FOR PIN 1 ORIENTATION IN TAPE

*All dimensions are nominal

Device	Package Type	Package Drawing	Pins	SPQ	Reel Diameter (mm)	Reel Width W1 (mm)	A0 (mm)	B0 (mm)	K0 (mm)	P1 (mm)	W (mm)	Pin1 Quadrant
ISO7420DR	SOIC	D	8	2500	330.0	12.4	6.4	5.2	2.1	8.0	12.0	Q1
ISO7420MDR	SOIC	D	8	2500	330.0	12.4	6.4	5.2	2.1	8.0	12.0	Q1
ISO7421DR	SOIC	D	8	2500	330.0	12.4	6.4	5.2	2.1	8.0	12.0	Q1

TAPE AND REEL BOX DIMENSIONS



*All dimensions are nominal

Device	Package Type	Package Drawing	Pins	SPQ	Length (mm)	Width (mm)	Height (mm)
ISO7420DR	SOIC	D	8	2500	350.0	350.0	43.0
ISO7420MDR	SOIC	D	8	2500	350.0	350.0	43.0
ISO7421DR	SOIC	D	8	2500	350.0	350.0	43.0

TUBE

*All dimensions are nominal

Device	Package Name	Package Type	Pins	SPQ	L (mm)	W (mm)	T (μm)	B (mm)
ISO7420D	D	SOIC	8	75	505.46	6.76	3810	4
ISO7420MD	D	SOIC	8	75	505.46	6.76	3810	4
ISO7421D	D	SOIC	8	75	505.46	6.76	3810	4

EXAMPLE BOARD LAYOUT

D0008A

SOIC - 1.75 mm max height

SMALL OUTLINE INTEGRATED CIRCUIT

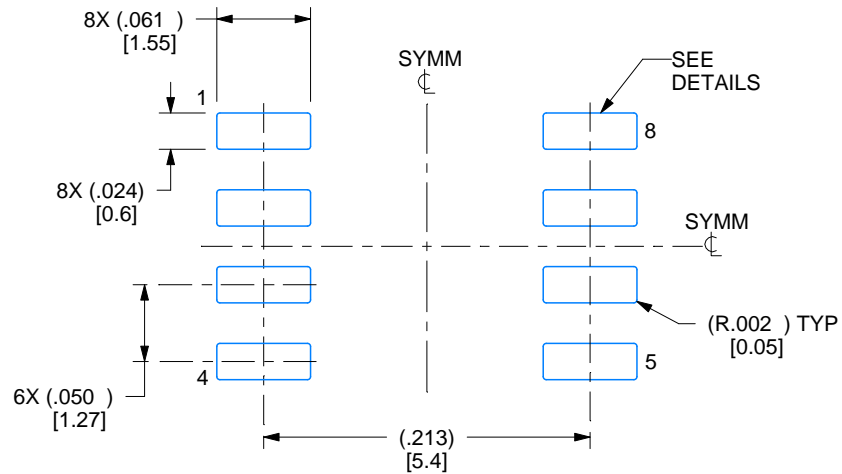

LAND PATTERN EXAMPLE
EXPOSED METAL SHOWN
SCALE:8X

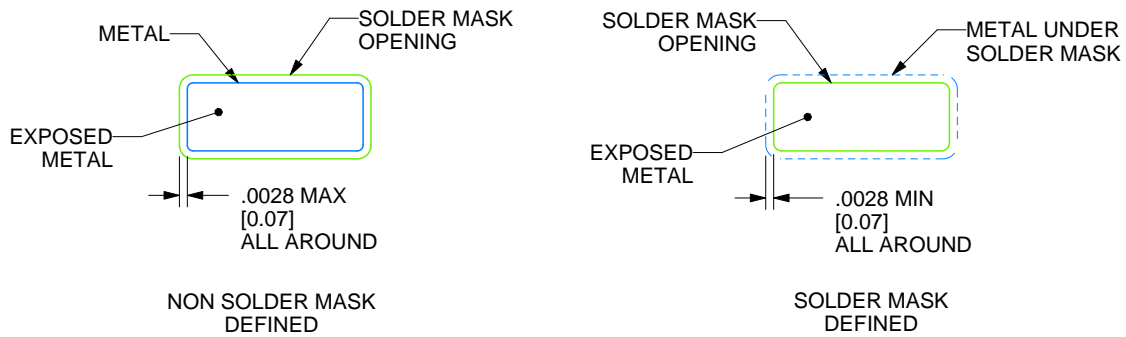

SOLDER MASK DETAILS

4214825/C 02/2019

NOTES: (continued)

6. Publication IPC-7351 may have alternate designs.

7. Solder mask tolerances between and around signal pads can vary based on board fabrication site.

EXAMPLE STENCIL DESIGN

D0008A

SOIC - 1.75 mm max height

SMALL OUTLINE INTEGRATED CIRCUIT



SOLDER PASTE EXAMPLE
BASED ON .005 INCH [0.125 MM] THICK STENCIL
SCALE:8X

4214825/C 02/2019

NOTES: (continued)

8. Laser cutting apertures with trapezoidal walls and rounded corners may offer better paste release. IPC-7525 may have alternate design recommendations.
9. Board assembly site may have different recommendations for stencil design.

IMPORTANT NOTICE AND DISCLAIMER

TI PROVIDES TECHNICAL AND RELIABILITY DATA (INCLUDING DATA SHEETS), DESIGN RESOURCES (INCLUDING REFERENCE DESIGNS), APPLICATION OR OTHER DESIGN ADVICE, WEB TOOLS, SAFETY INFORMATION, AND OTHER RESOURCES "AS IS" AND WITH ALL FAULTS, AND DISCLAIMS ALL WARRANTIES, EXPRESS AND IMPLIED, INCLUDING WITHOUT LIMITATION ANY IMPLIED WARRANTIES OF MERCHANTABILITY, FITNESS FOR A PARTICULAR PURPOSE OR NON-INFRINGEMENT OF THIRD PARTY INTELLECTUAL PROPERTY RIGHTS.

These resources are intended for skilled developers designing with TI products. You are solely responsible for (1) selecting the appropriate TI products for your application, (2) designing, validating and testing your application, and (3) ensuring your application meets applicable standards, and any other safety, security, regulatory or other requirements.

These resources are subject to change without notice. TI grants you permission to use these resources only for development of an application that uses the TI products described in the resource. Other reproduction and display of these resources is prohibited. No license is granted to any other TI intellectual property right or to any third party intellectual property right. TI disclaims responsibility for, and you will fully indemnify TI and its representatives against, any claims, damages, costs, losses, and liabilities arising out of your use of these resources.



TI's products are provided subject to [TI's Terms of Sale](#) or other applicable terms available either on [ti.com](https://www.ti.com) or provided in conjunction with such TI products. TI's provision of these resources does not expand or otherwise alter TI's applicable warranties or warranty disclaimers for TI products.

TI objects to and rejects any additional or different terms you may have proposed.

Mailing Address: Texas Instruments, Post Office Box 655303, Dallas, Texas 75265
Copyright © 2023, Texas Instruments Incorporated

Looking for pricing, stock, or lifecycle information?

Click below to explore more details on WIN SOURCE:

-  [View ISO7421DR](#) on WIN SOURCE
-  [Texas Instruments](#) Information

Optimize Your Supply Chain with WIN SOURCE Solutions

-  Global Sourcing Solution
-  Obsolete Management
-  Cost Control Management
-  Shortage Management
-  Alternative Solution
-  Excess Inventory Management