



## ISO7420FCC Low-Power Dual Channel Digital Isolator

### 1 Features

- Signaling Rate: 50 Mbps (5-V Supplies)
- Output is Low in Default Mode
- Integrated Noise Filter on the Input Pins
- Low Power Consumption: Typical  $I_{CC}$  per Channel
  - 1.8 mA at 1 Mbps, 3.9 mA at 25 Mbps (5-V Supplies)
  - 1.4 mA at 1 Mbps, 2.6 mA at 25 Mbps (3.3-V Supplies)
- Low Propagation Delay: 20 ns Typical (5-V Supplies)
- Channel-to-Channel Output Skew: 2 ns Maximum
- 3.3-V and 5-V Level Translation
- Wide  $T_A$  Range Specified:  $-40^{\circ}\text{C}$  to  $125^{\circ}\text{C}$
- 60-KV/ $\mu\text{s}$  Transient Immunity, Typical (5-V Supplies)
- Low Emissions
- Isolation Barrier Life: > 25 Years
- Operates from 2.7-V to 5.5-V Supply Levels
- Narrow Body SOIC-8 Package
- Safety and Regulatory Approvals
  - 4242  $V_{PK}$  Isolation per DIN V VDE V 0884-10 (VDE V 0884-10):2006-12
  - 2.5  $KV_{RMS}$  Isolation for 1 Minute per UL 1577
  - CSA Component Acceptance Notice 5A, IEC 60950-1 and IEC 61010-1 End Equipment Standards
  - GB4943.1-2011 CQC Certification

### 2 Applications

- Opto-Coupler Replacement in:
  - Industrial FieldBus
    - ProfiBus
    - ModBus
    - DeviceNet™ Data Buses
  - Servo Control Interface
  - Motor Control
  - Power Supplies
  - Battery Packs

### 3 Description

ISO7420FCC provides galvanic isolation up to 2500  $V_{RMS}$  for 1 minute per UL and 4242  $V_{PK}$  per VDE. This device has two isolated channels. Each channel has a logic input and output buffer separated by a silicon dioxide ( $\text{SiO}_2$ ) insulation barrier. Used in conjunction with isolated power supplies, this device prevents noise currents on a data bus or other circuit from entering the local ground and interfering with or damaging sensitive circuitry. The suffix F indicates low-output option in fail-safe conditions (see Table 2). This device has integrated noise filter for harsh environments where short noise pulses may be present at the device input pins.

ISO7420FCC has TTL input thresholds and operates from 2.7-V to 5.5-V supplies. All inputs are 5-V tolerant when supplied from a 2.7-V or 3.3-V supply.

#### Device Information<sup>(1)</sup>

PART NUMBER	PACKAGE	BODY SIZE (NOM)
ISO7420FCC	SOIC (8)	4.90 mm x 3.91 mm

(1) For all available packages, see the orderable addendum at the end of the datasheet.

#### Simplified Schematic

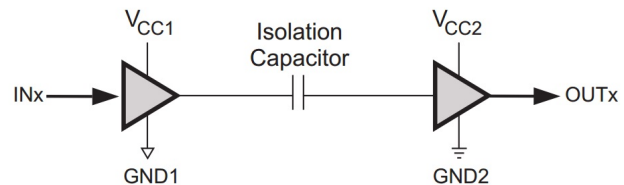

## Table of Contents

<b>1 Features</b> .....	<b>1</b>	<b>7 Parameter Measurement Information</b> .....	<b>10</b>
<b>2 Applications</b> .....	<b>1</b>	<b>8 Detailed Description</b> .....	<b>11</b>
<b>3 Description</b> .....	<b>1</b>	8.1 Overview .....	11
<b>4 Revision History</b> .....	<b>2</b>	8.2 Functional Block Diagram .....	11
<b>5 Pin Configuration and Functions</b> .....	<b>3</b>	8.3 Feature Description .....	12
<b>6 Specifications</b> .....	<b>3</b>	8.4 Device Functional Modes .....	15
6.1 Absolute Maximum Ratings .....	3	<b>9 Application and Implementation</b> .....	<b>16</b>
6.2 ESD Ratings .....	3	9.1 Application Information .....	16
6.3 Recommended Operating Conditions .....	4	9.2 Typical Application .....	16
6.4 Thermal Information .....	4	<b>10 Power Supply Recommendations</b> .....	<b>19</b>
6.5 Electrical Characteristics: $V_{CC1}$ and $V_{CC2} = 5\text{ V} \pm 10\%$ .....	5	<b>11 Layout</b> .....	<b>19</b>
6.6 Electrical Characteristics: $V_{CC1}$ and $V_{CC2} = 3.3\text{ V} \pm 10\%$ .....	5	11.1 Layout Guidelines .....	19
6.7 Electrical Characteristics: $V_{CC1}$ and $V_{CC2} = 2.7\text{ V}$ .....	6	11.2 Layout Example .....	19
6.8 Power Dissipation Characteristics .....	6	<b>12 Device and Documentation Support</b> .....	<b>20</b>
6.9 Switching Characteristics: $V_{CC1}$ and $V_{CC2} = 5\text{ V} \pm 10\%$ .....	7	12.1 Documentation Support .....	20
6.10 Switching Characteristics: $V_{CC1}$ and $V_{CC2} = 3.3\text{ V} \pm 10\%$ .....	7	12.2 Community Resources .....	20
6.11 Switching Characteristics: $V_{CC1}$ and $V_{CC2} = 2.7\text{ V}$ .....	7	12.3 Trademarks .....	20
6.12 Typical Characteristics .....	8	12.4 Electrostatic Discharge Caution .....	20
		12.5 Glossary .....	20
		<b>13 Mechanical, Packaging, and Orderable Information</b> .....	<b>20</b>

## 4 Revision History

NOTE: Page numbers for previous revisions may differ from page numbers in the current version.

Changes from Revision B (January 2014) to Revision C	Page
• Added <i>Pin Configuration and Functions</i> section, <i>ESD Ratings</i> table, <i>Feature Description</i> section, <i>Device Functional Modes</i> , <i>Application and Implementation</i> section, <i>Power Supply Recommendations</i> section, <i>Layout</i> section, <i>Device and Documentation Support</i> section, and <i>Mechanical, Packaging, and Orderable Information</i> section .....	1
• VDE standard changed to DIN V VDE V 0884-10 (VDE V 0884-10): 2006-12 .....	1
• Changed VDE standard changed to DIN V VDE V 0884-10 (VDE V 0884-10):2006-12 .....	1
• Changed Note 1 <a href="#">Figure 12</a> .....	10
• Changed <a href="#">Figure 13</a> .....	10

Changes from Revision A (July 2013) to Revision B	Page
• Changed the SAFETY AND REGULATORY APPROVALS list .....	1
• Changed the $V_{IH}$ MAX value From: $V_{CC}$ To: 5.5V in the RECOMMENDED OPERATING CONDITIONS table .....	4
• Changed the $V_{PR}$ and $V_{IOTM}$ parameter From: DIN EN 60747-5-2 To: DIN EN 60747-5-5 in the INSULATION CHARACTERISTICS table .....	13
• Changed the REGULATORY INFORMATION table .....	13
• Changed the title of <a href="#">Figure 16</a> From: $\theta_{JC}$ Thermal Derating Curve per DIN EN 60747-5-2 To: $\theta_{JC}$ Thermal Derating Curve per DIN EN 60747-5-5 .....	14

Changes from Original (June 2013) to Revision A	Page
• Changed High-level output voltage MIN Value From: $V_{CCx}$ To: $V_{CC2}$ .....	5
• Changed High-level output voltage MIN Value From: $V_{CCx}$ To: $V_{CC2}$ and removed Note 1 .....	5
• Changed High-level output voltage MIN Value From: $V_{CCx}$ To: $V_{CC2}$ and removed Note 1 .....	6
• Changed <a href="#">Figure 3</a> X axis values .....	8

## 5 Pin Configuration and Functions

ISO7420: D Package  
8-Pin SOIC  
Top View

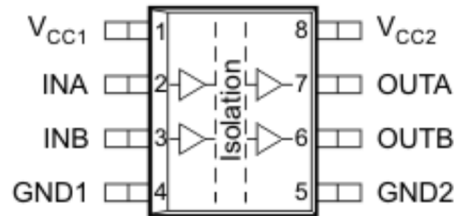

Pin Functions

PIN		I/O	DESCRIPTION
NAME	NO.		
GND1	4	–	Ground connection for $V_{CC1}$
GND2	5	–	Ground connection for $V_{CC2}$
INA	2	I	Input, channel A
INB	3	I	Input, channel B
OUTA	7	O	Output, channel A
OUTB	6	O	Output, channel B
$V_{CC1}$	1	–	Power supply, $V_{CC1}$
$V_{CC2}$	8	–	Power supply, $V_{CC2}$

## 6 Specifications

### 6.1 Absolute Maximum Ratings

see <sup>(1)</sup>

		MIN	MAX	UNIT
$V_{CC1}, V_{CC2}$	Supply voltage <sup>(2)</sup>	–0.5	6	V
$V_{IO}$	Voltage at INx, OUTx	–0.5	$V_{CC} + 0.5$ <sup>(3)</sup>	V
$I_O$	Output current	–15	15	mA
$T_{J(Max)}$	Maximum junction temperature		150	°C
$T_{stg}$	Storage temperature	–65	150	°C

- (1) Stresses beyond those listed under *Absolute Maximum Ratings* may cause permanent damage to the device. These are stress ratings only and functional operation of the device at these or any other conditions beyond those indicated under *Recommended Operating Conditions* is not implied. Exposure to absolute-maximum-rated conditions for extended periods may affect device reliability.
- (2) All voltage values except differential I/O bus voltages are with respect to network ground terminal and are peak voltage values.
- (3) Maximum voltage must not exceed 6 V.

### 6.2 ESD Ratings

		VALUE	UNIT
$V_{(ESD)}$	Electrostatic discharge	Human body model (HBM), per ANSI/ESDA/JEDEC JS-001 <sup>(1)</sup>	±4000
		Charged-device model (CDM), per JEDEC specification JESD22-C101 <sup>(2)</sup>	±1500

- (1) JEDEC document JEP155 states that 500-V HBM allows safe manufacturing with a standard ESD control process.
- (2) JEDEC document JEP157 states that 250-V CDM allows safe manufacturing with a standard ESD control process.

### 6.3 Recommended Operating Conditions

		MIN	NOM	MAX	UNIT
$V_{CC1}, V_{CC2}$	Supply voltage	2.7		5.5	V
$I_{OH}$	High-level output current ( $V_{CC} \geq 3$ V)	-4			mA
	High-level output current ( $V_{CC} < 3$ V)	-2			mA
$I_{OL}$	Low-level output current			4	mA
$V_{IH}$	High-level input voltage	2		5.5	V
$V_{IL}$	Low-level input voltage	0		0.8	V
$t_{ui}$	Input pulse duration	$\geq 4.5$ -V Operation	20		ns
		$< 4.5$ -V Operation	25		
$1 / t_{ui}$	Signaling rate	$\geq 4.5$ -V Operation	0	50	Mbps
		$< 4.5$ -V Operation	0	40	
$T_J$ <sup>(1)</sup>	Junction temperature	-40		136	°C
$T_A$	Ambient temperature	-40	25	125	°C

(1) To maintain the recommended operating conditions for  $T_J$ , see the [Power Dissipation Characteristics](#) table.

### 6.4 Thermal Information

THERMAL METRIC <sup>(1)</sup>		ISO7420FCC	UNIT
		D (SOIC)	
		8 PINS	
$R_{\theta JA}$	Junction-to-ambient thermal resistance	115.1	°C/W
$R_{\theta JC(top)}$	Junction-to-case (top) thermal resistance	60.1	°C/W
$R_{\theta JB}$	Junction-to-board thermal resistance	56.4	°C/W
$\Psi_{JT}$	Junction-to-top characterization parameter	17.2	°C/W
$\Psi_{JB}$	Junction-to-board characterization parameter	55.8	°C/W

(1) For more information about traditional and new thermal metrics, see the *Semiconductor and IC Package Thermal Metrics* application report, [SPRA953](#).

## 6.5 Electrical Characteristics: $V_{CC1}$ and $V_{CC2} = 5\text{ V} \pm 10\%$

 $T_A = -40^\circ\text{C}$  to  $125^\circ\text{C}$ 

PARAMETER		TEST CONDITIONS	MIN	TYP	MAX	UNIT
$V_{OH}$	High-level output voltage	$I_{OH} = -4\text{ mA}$ ; see <a href="#">Figure 12</a> .	$V_{CC2} - 0.5$	4.8		V
		$I_{OH} = -20\ \mu\text{A}$ ; see <a href="#">Figure 12</a> .	$V_{CC2} - 0.1$	5		
$V_{OL}$	Low-level output voltage	$I_{OL} = 4\text{ mA}$ ; see <a href="#">Figure 12</a> .		0.2	0.4	V
		$I_{OL} = 20\ \mu\text{A}$ ; see <a href="#">Figure 12</a> .		0	0.1	
$V_{I(HYS)}$	Input threshold voltage hysteresis			450		mV
$I_{IH}$	High-level input current	$IN_x = V_{CC1}$			10	$\mu\text{A}$
$I_{IL}$	Low-level input current	$IN_x = 0\text{ V}$	-10			$\mu\text{A}$
CMTI	Common-mode transient immunity	$V_I = V_{CC1}$ or $0\text{ V}$ ; see <a href="#">Figure 14</a> .	25	60		kV/ $\mu\text{s}$
<b>SUPPLY CURRENT (ALL INPUTS SWITCHING WITH SQUARE WAVE CLOCK SIGNAL FOR DYNAMIC <math>I_{CC}</math> MEASUREMENT)</b>						
$I_{CC1}$	Supply current for $V_{CC1}$ and $V_{CC2}$	DC to 1 Mbps	DC Input: $V_I = V_{CC1}$ or $0\text{ V}$ , AC Input: $C_L = 15\text{pF}$	0.5	1.1	mA
$I_{CC2}$				3	4.6	
$I_{CC1}$		10 Mbps	$C_L = 15\text{pF}$	1	1.5	
$I_{CC2}$				4	6	
$I_{CC1}$		25 Mbps	$C_L = 15\text{pF}$	1.7	2.5	
$I_{CC2}$				6	8.5	
$I_{CC1}$		50 Mbps	$C_L = 15\text{pF}$	2.7	4	
$I_{CC2}$				8.5	12	

## 6.6 Electrical Characteristics: $V_{CC1}$ and $V_{CC2} = 3.3\text{ V} \pm 10\%$

 $T_A = -40^\circ\text{C}$  to  $125^\circ\text{C}$ 

PARAMETER		TEST CONDITIONS	MIN	TYP	MAX	UNIT
$V_{OH}$	High-level output voltage	$I_{OH} = -4\text{ mA}$ ; see <a href="#">Figure 12</a> .	$V_{CC2} - 0.5$	3		V
		$I_{OH} = -20\ \mu\text{A}$ ; see <a href="#">Figure 12</a> .	$V_{CC2} - 0.1$	3.3		
$V_{OL}$	Low-level output voltage	$I_{OL} = 4\text{ mA}$ ; see <a href="#">Figure 12</a> .		0.2	0.4	V
		$I_{OL} = 20\ \mu\text{A}$ ; see <a href="#">Figure 12</a> .		0	0.1	
$V_{I(HYS)}$	Input threshold voltage hysteresis			425		mV
$I_{IH}$	High-level input current	$IN_x = V_{CC1}$			10	$\mu\text{A}$
$I_{IL}$	Low-level input current	$IN_x = 0\text{ V}$	-10			$\mu\text{A}$
CMTI	Common-mode transient immunity	$V_I = V_{CC1}$ or $0\text{ V}$ ; see <a href="#">Figure 14</a> .	25	40		kV/ $\mu\text{s}$
<b>SUPPLY CURRENT (ALL INPUTS SWITCHING WITH SQUARE WAVE CLOCK SIGNAL FOR DYNAMIC <math>I_{CC}</math> MEASUREMENT)</b>						
$I_{CC1}$	Supply current for $V_{CC1}$ and $V_{CC2}$	DC to 1 Mbps	DC Input: $V_I = V_{CC1}$ or $0\text{ V}$ , AC Input: $C_L = 15\text{pF}$	0.3	0.8	mA
$I_{CC2}$				2.4	3.3	
$I_{CC1}$		10 Mbps	$C_L = 15\text{pF}$	0.6	1.2	
$I_{CC2}$				3.1	4.5	
$I_{CC1}$		25 Mbps	$C_L = 15\text{pF}$	1	2	
$I_{CC2}$				4.2	6.1	
$I_{CC1}$		40 Mbps	$C_L = 15\text{pF}$	1.3	2.3	
$I_{CC2}$				5.3	7.5	

## 6.7 Electrical Characteristics: $V_{CC1}$ and $V_{CC2} = 2.7\text{ V}$

 $T_A = -40^\circ\text{C}$  to  $125^\circ\text{C}$ 

PARAMETER		TEST CONDITIONS	MIN	TYP	MAX	UNIT
$V_{OH}$	High-level output voltage	$I_{OH} = -2\text{ mA}$ ; see <a href="#">Figure 12</a> .	$V_{CC2} - 0.3$	2.5		V
		$I_{OH} = -20\ \mu\text{A}$ ; see <a href="#">Figure 12</a> .	$V_{CC2} - 0.1$	2.7		
$V_{OL}$	Low-level output voltage	$I_{OL} = 4\text{ mA}$ ; see <a href="#">Figure 12</a> .		0.2	0.4	V
		$I_{OL} = 20\ \mu\text{A}$ ; see <a href="#">Figure 12</a> .		0	0.1	
$V_{I(HYS)}$	Input threshold voltage hysteresis			350		mV
$I_{IH}$	High-level input current	$I_{Nx} = V_{CC1}$			10	$\mu\text{A}$
$I_{IL}$	Low-level input current	$I_{Nx} = 0\text{ V}$	-10			$\mu\text{A}$
CMTI	Common-mode transient immunity	$V_I = V_{CC1}$ or $0\text{ V}$ ; see <a href="#">Figure 14</a> .	25	35		kV/ $\mu\text{s}$
<b>SUPPLY CURRENT (ALL INPUTS SWITCHING WITH SQUARE WAVE CLOCK SIGNAL FOR DYNAMIC <math>I_{CC}</math> MEASUREMENT)</b>						
$I_{CC1}$	Supply current for $V_{CC1}$ and $V_{CC2}$	DC to 1 Mbps	DC Input: $V_I = V_{CC1}$ or $0\text{ V}$ , AC Input: $C_L = 15\text{ pF}$	0.15	0.4	mA
$I_{CC2}$				2.1	3.1	
$I_{CC1}$		10 Mbps	$C_L = 15\text{ pF}$	0.4	0.7	
$I_{CC2}$				2.7	4	
$I_{CC1}$		25 Mbps	$C_L = 15\text{ pF}$	0.7	1.2	
$I_{CC2}$				3.6	5	
$I_{CC1}$		40 Mbps	$C_L = 15\text{ pF}$	1	1.7	
$I_{CC2}$				4.4	6.3	

## 6.8 Power Dissipation Characteristics

THERMAL METRIC			ISO7420FCC	UNIT
			D (SOIC)	
			8 PINS	
$P_D$	Device power dissipation	$V_{CC1} = V_{CC2} = 5.5\text{ V}$ , $T_J = 150^\circ\text{C}$ , $C_L = 15\text{ pF}$ , Input a 50-Mbps 50% duty-cycle square wave	120	mW

## 6.9 Switching Characteristics: $V_{CC1}$ and $V_{CC2} = 5\text{ V} \pm 10\%$

 $T_A = -40^\circ\text{C}$  to  $125^\circ\text{C}$ 

PARAMETER		TEST CONDITIONS	MIN	TYP	MAX	UNIT
$t_{PLH}$ , $t_{PHL}$	Propagation delay time	See Figure 12.	10	20	37	ns
PWD <sup>(1)</sup>	Pulse width distortion $ t_{PHL} - t_{PLH} $			2.5	5	ns
$t_{sk(o)}$ <sup>(2)</sup>	Channel-to-channel output skew time				2	ns
$t_{sk(pp)}$ <sup>(3)</sup>	Part-to-part skew time				12	ns
$t_r$	Output signal rise time	See Figure 12.		2.5		ns
$t_f$	Output signal fall time			2.5		ns
$t_{GS}$	Pulse width of glitches suppressed by the input filter			12		ns
$t_{fs}$	Fail-safe output delay time from input data or power loss	See Figure 13.		8		$\mu\text{s}$

- (1) Also known as pulse skew.
- (2)  $t_{sk(o)}$  is the skew between outputs of a single device with all driving inputs connected together and the outputs switching in the same direction while driving identical loads.
- (3)  $t_{sk(pp)}$  is the magnitude of the difference in propagation delay times between any terminals of different devices switching in the same direction while operating at identical supply voltages, temperature, input signals and loads.

## 6.10 Switching Characteristics: $V_{CC1}$ and $V_{CC2} = 3.3\text{ V} \pm 10\%$

over operating free-air temperature range (unless otherwise noted)

PARAMETER		TEST CONDITIONS	MIN	TYP	MAX	UNIT
$t_{PLH}$ , $t_{PHL}$	Propagation delay time	See Figure 12.	10	22	40	ns
PWD <sup>(1)</sup>	Pulse width distortion $ t_{PHL} - t_{PLH} $				3	ns
$t_{sk(o)}$ <sup>(2)</sup>	Channel-to-channel output skew time				2	ns
$t_{sk(pp)}$ <sup>(3)</sup>	Part-to-part skew time				19	ns
$t_r$	Output signal rise time	See Figure 12.		3		ns
$t_f$	Output signal fall time			3		ns
$t_{GS}$	Pulse width of glitches suppressed by the input filter			12.5		ns
$t_{fs}$	Fail-safe output delay time from input power loss	See Figure 13.		8		$\mu\text{s}$

- (1) Also known as pulse skew.
- (2)  $t_{sk(o)}$  is the skew between outputs of a single device with all driving inputs connected together and the outputs switching in the same direction while driving identical loads.
- (3)  $t_{sk(pp)}$  is the magnitude of the difference in propagation delay times between any terminals of different devices switching in the same direction while operating at identical supply voltages, temperature, input signals and loads.

## 6.11 Switching Characteristics: $V_{CC1}$ and $V_{CC2} = 2.7\text{ V}$

 $T_A = -40^\circ\text{C}$  to  $125^\circ\text{C}$ 

PARAMETER		TEST CONDITIONS	MIN	TYP	MAX	UNIT
$t_{PLH}$ , $t_{PHL}$	Propagation delay time	See Figure 12.	15	26	45	ns
PWD <sup>(1)</sup>	Pulse width distortion $ t_{PHL} - t_{PLH} $				3	ns
$t_{sk(o)}$ <sup>(2)</sup>	Channel-to-channel output skew time				2	ns
$t_{sk(pp)}$ <sup>(3)</sup>	Part-to-part skew time				22	ns
$t_r$	Output signal rise time	See Figure 12.		3		ns
$t_f$	Output signal fall time			3		ns
$t_{GS}$	Pulse width of glitches suppressed by the input filter			13.5		ns
$t_{fs}$	Fail-safe output delay time from input power loss	See Figure 13.		8		$\mu\text{s}$

- (1) Also known as pulse skew.
- (2)  $t_{sk(o)}$  is the skew between outputs of a single device with all driving inputs connected together and the outputs switching in the same direction while driving identical loads.
- (3)  $t_{sk(pp)}$  is the magnitude of the difference in propagation delay times between any terminals of different devices switching in the same direction while operating at identical supply voltages, temperature, input signals and loads.

### 6.12 Typical Characteristics

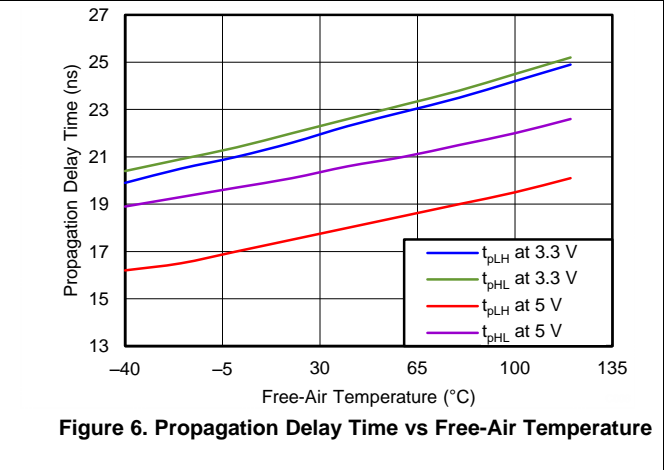
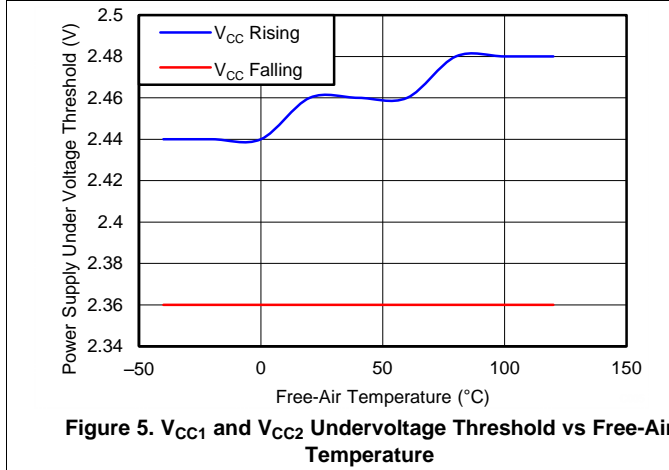
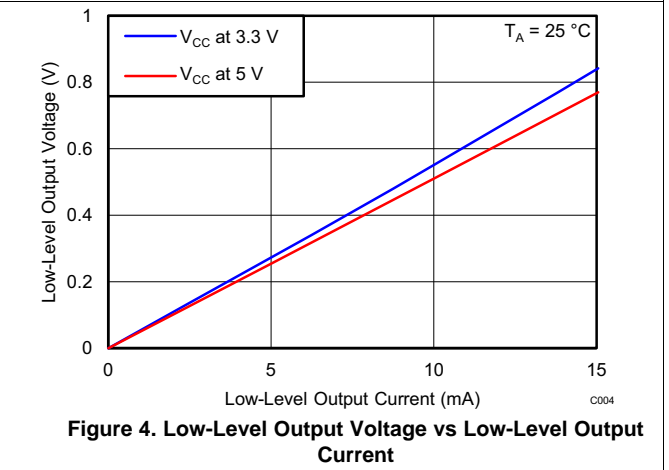
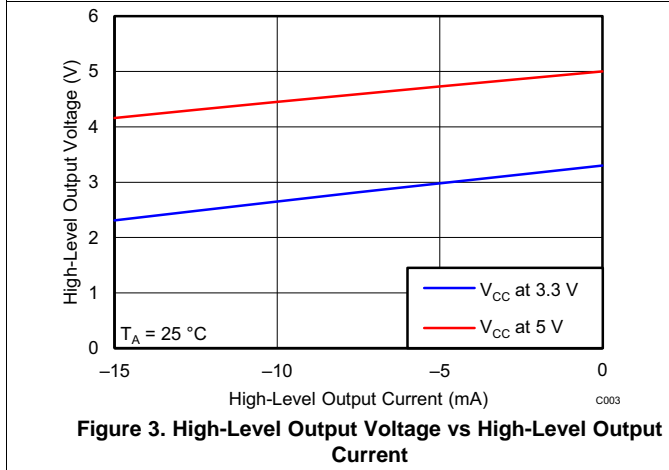
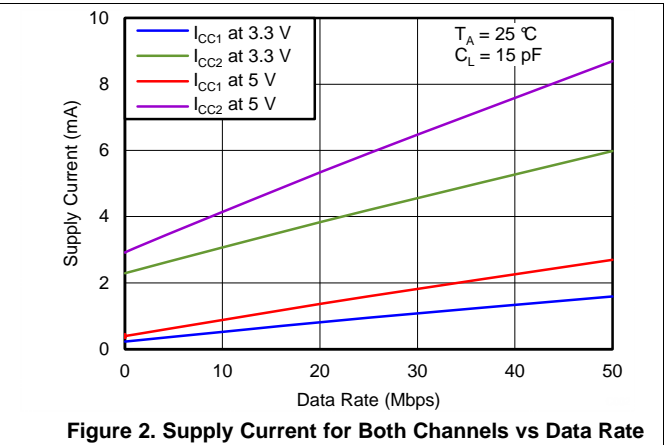
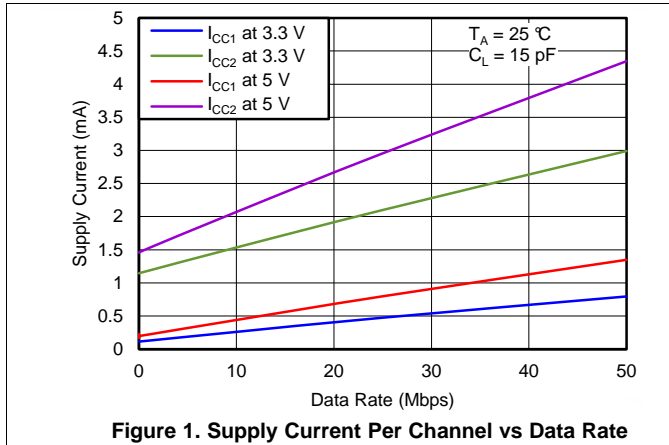

Typical Characteristics (continued)

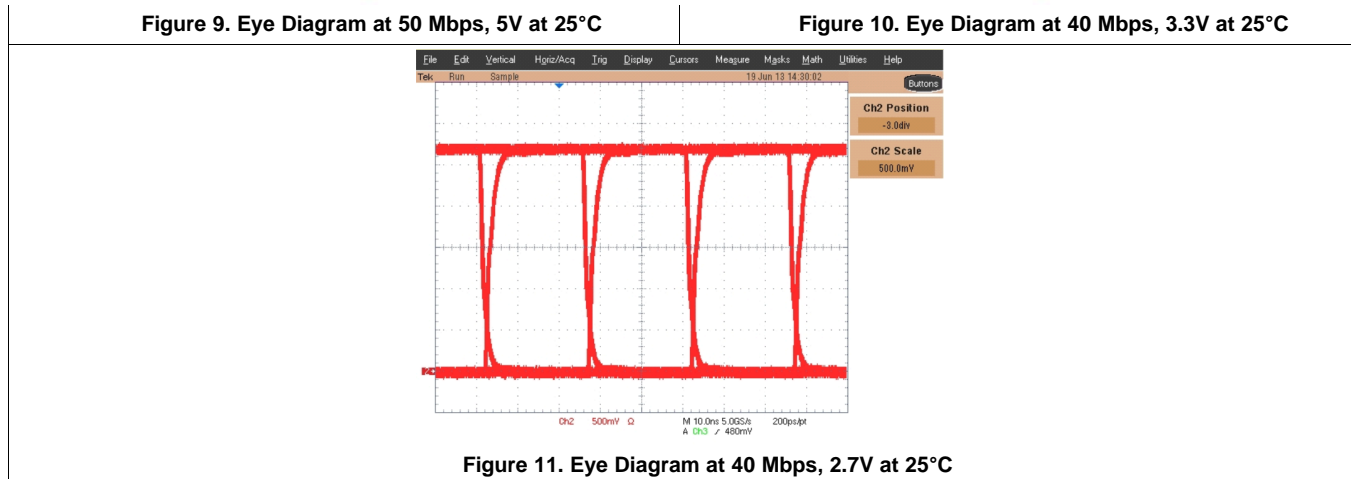
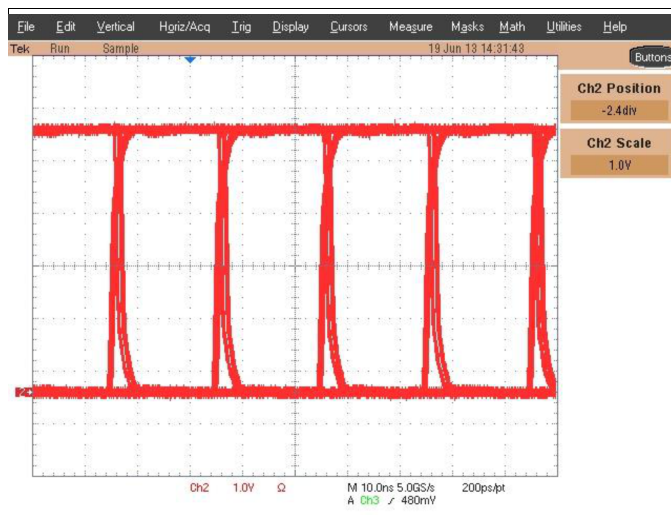
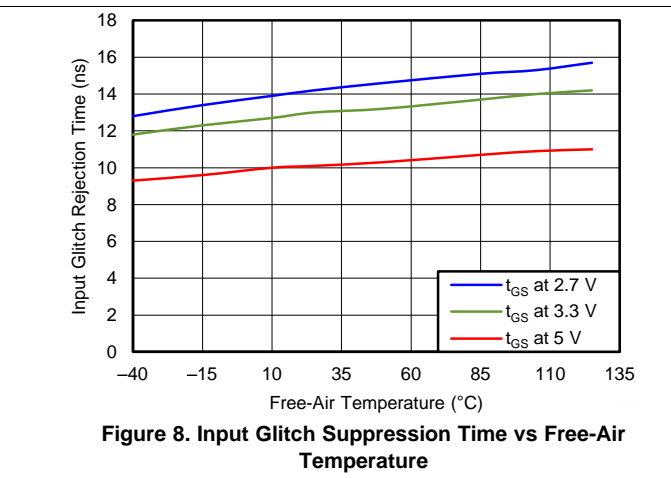
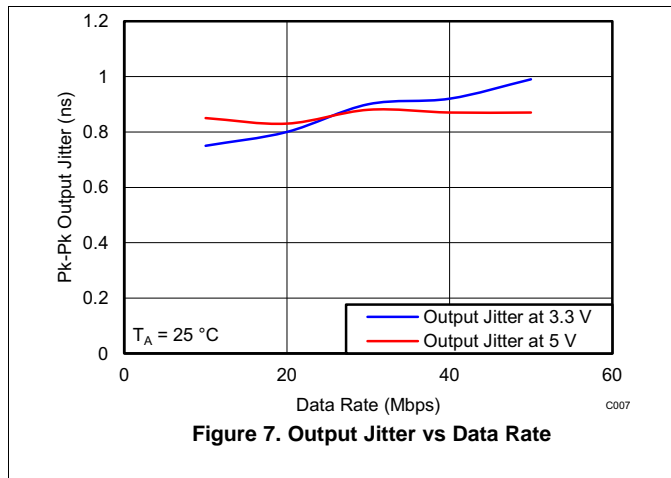

## 7 Parameter Measurement Information

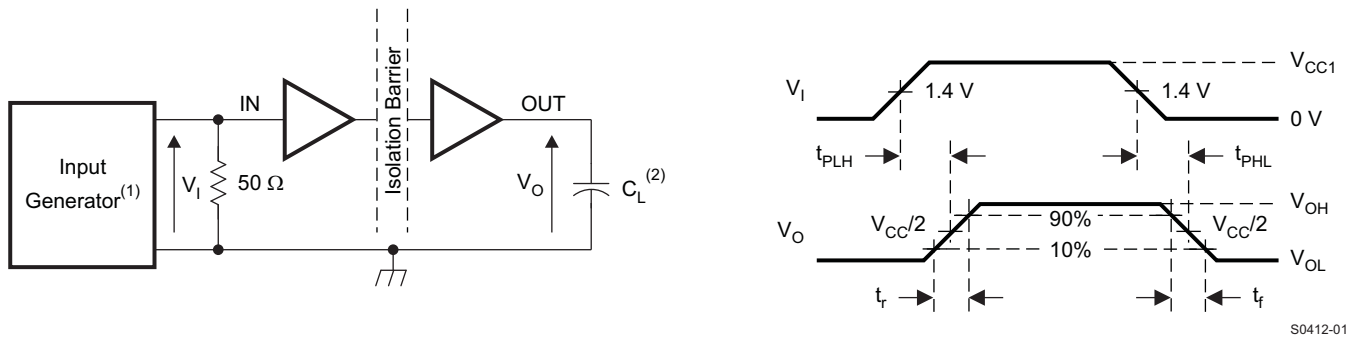

- (1) The input pulse is supplied by a generator having the following characteristics: PRR  $\leq$  50 kHz, 50% duty cycle,  $t_r \leq$  3 ns,  $t_f \leq$  3 ns,  $Z_O = 50 \Omega$ . At the input, a 50- $\Omega$  resistor is required to terminate the Input Generator signal. It is not needed in actual application.
- (2)  $C_L = 15$  pF and includes instrumentation and fixture capacitance within  $\pm 20\%$ .

**Figure 12. Switching Characteristic Test Circuit and Voltage Waveforms**

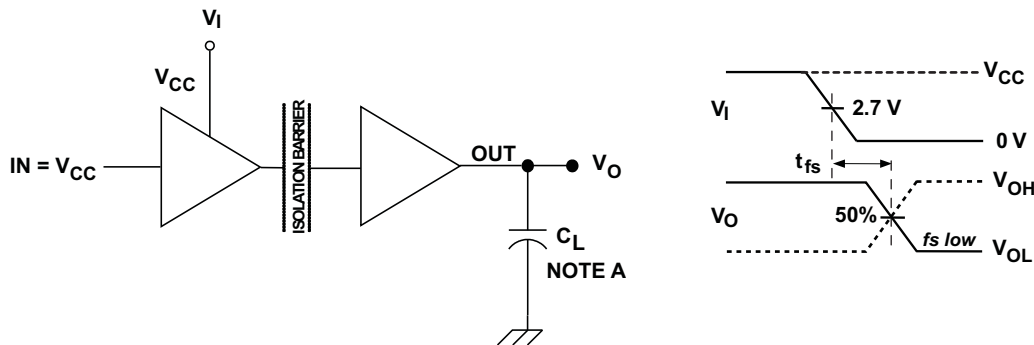

- A.  $C_L = 15$  pF and includes instrumentation and fixture capacitance within  $\pm 20\%$ .

**Figure 13. Fail-Safe Output Delay-Time Test Circuit and Voltage Waveforms**

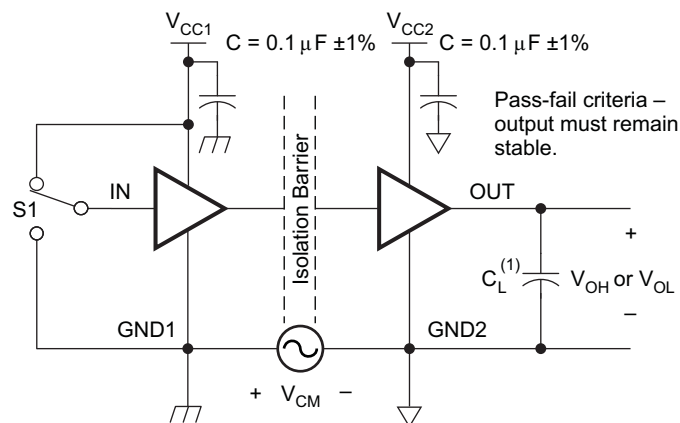

- (1)  $C_L = 15$  pF and includes instrumentation and fixture capacitance within  $\pm 20\%$ .

**Figure 14. Common-Mode Transient Immunity Test Circuit**

## 8 Detailed Description

### 8.1 Overview

The isolator in Figure 15 is based on a capacitive isolation barrier technique. The I/O channel of the device consists of two internal data channels, a high-frequency channel (HF) with a bandwidth from 100 kbps up to 50 Mbps, and a low-frequency channel (LF) covering the range from 100 kbps down to DC. In principle, a single-ended input signal entering the HF-channel is split into a differential signal via the inverter gate at the input. The following capacitor-resistor networks differentiate the signal into transients, which then are converted into differential pulses by two comparators. The comparator outputs drive a NOR-gate flip-flop whose output feeds an output multiplexer. A decision logic (DCL) at the driving output of the flip-flop measures the durations between signal transients. If the duration between two consecutive transients exceeds a certain time limit, (as in the case of a low-frequency signal), the DCL forces the output-multiplexer to switch from the high- to the low-frequency channel.

Because low-frequency input signals require the internal capacitors to assume prohibitively large values, these signals are pulse-width modulated (PWM) with the carrier frequency of an internal oscillator, thus creating a sufficiently high frequency signal, capable of passing the capacitive barrier. As the input is modulated, a low-pass filter (LPF) is needed to remove the high-frequency carrier from the actual data before passing it on to the output multiplexer.

### 8.2 Functional Block Diagram

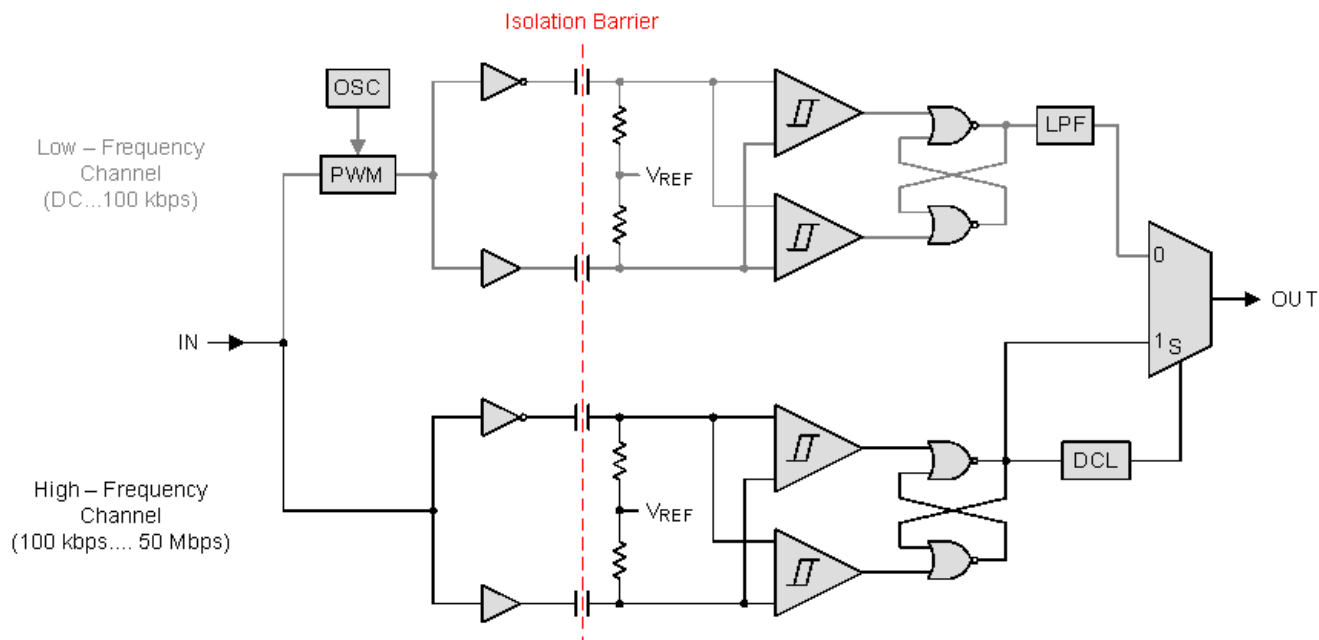

Figure 15. Conceptual Block Diagram of a Digital Capacitive Isolator

## 8.3 Feature Description

### 8.3.1 Insulation and Safety-Related Specifications for SOIC-8 Package

over recommended operating conditions (unless otherwise noted)

PARAMETER		TEST CONDITIONS	MIN	TYP	MAX	UNIT
L(I01)	Minimum air gap (clearance)	Shortest terminal-to-terminal distance through air	4			mm
L(I02)	Minimum external tracking (creepage)	Shortest terminal-to-terminal distance across the package surface	4			mm
CTI	Tracking resistance (comparative tracking index)	DIN EN 60112 (VDE 0303-11); IEC 60112	>400			V
DTI	Distance through the insulation	Minimum internal gap (internal clearance)	0.014			mm
R <sub>IO</sub>	Isolation resistance, input to output <sup>(1)</sup>	V <sub>IO</sub> = 500 V, T <sub>A</sub> = 25°C		>10 <sup>12</sup>		Ω
		V <sub>IO</sub> = 500 V, 100°C ≤ T <sub>A</sub> ≤ 125°C		>10 <sup>11</sup>		Ω
C <sub>IO</sub>	Barrier capacitance, input to output <sup>(1)</sup>	V <sub>IO</sub> = 0.4 sin (2πft), f = 1 MHz		1		pF
C <sub>I</sub>	Input capacitance <sup>(2)</sup>	V <sub>I</sub> = V <sub>CC</sub> /2 + 0.4 sin (2πft), f = 1 MHz, V <sub>CC</sub> = 5 V		1		pF

(1) All pins on each side of the barrier tied together creating a two-terminal device.

(2) Measured from input pin to ground.

#### NOTE

Creepage and clearance requirements should be applied according to the specific equipment isolation standards of an application. Care should be taken to maintain the creepage and clearance distance of a board design to ensure that the mounting pads of the isolator on the printed-circuit board do not reduce this distance.

Creepage and clearance on a printed-circuit board become equal in certain cases. Techniques such as inserting grooves and/or ribs on a printed circuit board are used to help increase these specifications.

### 8.3.2 Insulation Characteristics

over recommended operating conditions (unless otherwise noted)

PARAMETER		TEST CONDITIONS	SPECIFICATION	UNIT
<b>DIN V VDE V 0884-10 (VDE V 0884-10):2006-12<sup>(1)</sup></b>				
$V_{IORM}$	Maximum working isolation voltage		566	$V_{PK}$
$V_{PR}$	Input-to-output test voltage	Method a, After environmental tests subgroup 1, $V_{PR} = V_{IORM} \times 1.6$ , $t = 10$ s, Partial Discharge < 5 pC	906	$V_{PK}$
		Method b1, $V_{PR} = V_{IORM} \times 1.875$ , $t = 1$ s (100% Production test) Partial discharge < 5 pC	1062	
		After Input/Output safety test subgroup 2/3, $V_{PR} = V_{IORM} \times 1.2$ , $t = 10$ s, Partial discharge < 5 pC	680	
$V_{IOTM}$	Maximum transient isolation voltage	$V_{TEST} = V_{IOTM}$ $t = 60$ sec (qualification) $t = 1$ sec (100% production)	4242	$V_{PK}$
$R_S$	Isolation resistance	$V_{IO} = 500$ V at $T_S = 150^\circ\text{C}$	$>10^9$	$\Omega$
	Pollution degree		2	
<b>UL 1577</b>				
$V_{ISO}$	Isolation voltage	$V_{TEST} = V_{ISO} = 2500$ $V_{RMS}$ , $t = 60$ sec (qualification) $V_{TEST} = 1.2 \times V_{ISO} = 3000$ $V_{RMS}$ , $t = 1$ sec (100% production)	2500	$V_{RMS}$

(1) Climatic Classification 40/125/21

**Table 1. IEC 60664-1 Ratings Table**

PARAMETER	TEST CONDITIONS	SPECIFICATION
Material group		II
Installation classification	Rated mains voltage $\leq 150$ $V_{RMS}$	I–IV
	Rated mains voltage $\leq 300$ $V_{RMS}$	I–III

### 8.3.3 Regulatory Information

VDE	CSA	UL	CQC
Certified according to DIN V VDE V 0884-10 (VDE V 0884-10):2006-12 and DIN EN 61010-1 (VDE 0411-1):2011-07	Approved under CSA Component Acceptance Notice 5A, IEC 60950-1, and IEC 61010-1	Recognized under UL 1577 Component Recognition Program	Certified according to GB4943.1-2011
Basic Insulation Maximum Transient Isolation voltage, 4242 $V_{PK}$ ; Maximum Working Isolation Voltage, 566 $V_{PK}$	3000 $V_{RMS}$ Isolation Rating; 400 $V_{RMS}$ Basic and 200 $V_{RMS}$ Reinforced Insulation maximum working voltage per CSA 60950-1-07+A1 and IEC 60950-1 (2nd Ed)+A1; 300 $V_{RMS}$ Basic and 150 $V_{RMS}$ Reinforced Insulation maximum working voltage per CSA 61010-1-12 and IEC 61010-1 (3rd Ed)	Single Protection, 2500 $V_{RMS}$ <sup>(1)</sup>	Basic Insulation, Altitude $\leq 5000$ m, Tropical Climate, 250 $V_{RMS}$ maximum working voltage
Certificate number: 40016131	Master contract number: 220991	File number: E181974	Certificate number: CQC14001109540

(1) Production tested  $\geq 3000$   $V_{RMS}$  for 1 second in accordance with UL 1577.

### 8.3.4 Safety Limiting Values

Safety limiting intends to prevent potential damage to the isolation barrier upon failure of input or output circuitry. A failure of the I/O can allow low resistance to ground or the supply and, without current limiting, dissipate sufficient power to overheat the die and damage the isolation barrier, potentially leading to secondary system failures.

PARAMETER	TEST CONDITIONS	MIN	TYP	MAX	UNIT
I <sub>S</sub> Safety input, output, or supply current	$\theta_{JA} = 115.1^{\circ}\text{C/W}$ , $V_I = 5.5\text{ V}$ , $T_J = 150^{\circ}\text{C}$ , $T_A = 25^{\circ}\text{C}$			197	mA
	$\theta_{JA} = 115.1^{\circ}\text{C/W}$ , $V_I = 3.6\text{ V}$ , $T_J = 150^{\circ}\text{C}$ , $T_A = 25^{\circ}\text{C}$			302	
	$\theta_{JA} = 115.1^{\circ}\text{C/W}$ , $V_I = 2.7\text{ V}$ , $T_J = 150^{\circ}\text{C}$ , $T_A = 25^{\circ}\text{C}$			402	
T <sub>S</sub> Maximum Safety temperature				150	°C

The safety-limiting constraint is the absolute-maximum junction temperature specified in the [Absolute Maximum Ratings](#) table. The power dissipation and junction-to-air thermal impedance of the device installed in the application hardware determines the junction temperature. The assumed junction-to-air thermal resistance in the [Thermal Information](#) table is that of a device installed on a High-K Test Board for Leaded Surface-Mount Packages. The power is the recommended maximum input voltage times the current. The junction temperature is then the ambient temperature plus the power times the junction-to-air thermal resistance.

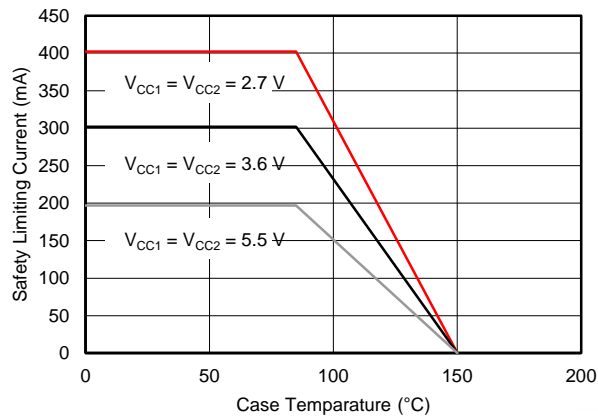

Figure 16.  $\theta_{JC}$  Thermal Derating Curve per VDE

## 8.4 Device Functional Modes

Table 2. Function Table<sup>(1)</sup>

V <sub>CC1</sub>	V <sub>CC2</sub>	INPUT INA, INB	OUTPUT OUTA, OUTB
PU	PU	H	H
		L	L
		Open	L <sup>(2)</sup>
PD	PU	X	L <sup>(2)</sup>
X	PD	X	Undetermined

(1) PU = Powered up (V<sub>CC</sub> ≥ 2.7 V); PD = Powered down (V<sub>CC</sub> ≤ 2.1 V);  
X = Irrelevant; H = High level; L = Low level

(2) In fail-safe condition, output defaults to low level

### 8.4.1 Device I/O Schematics

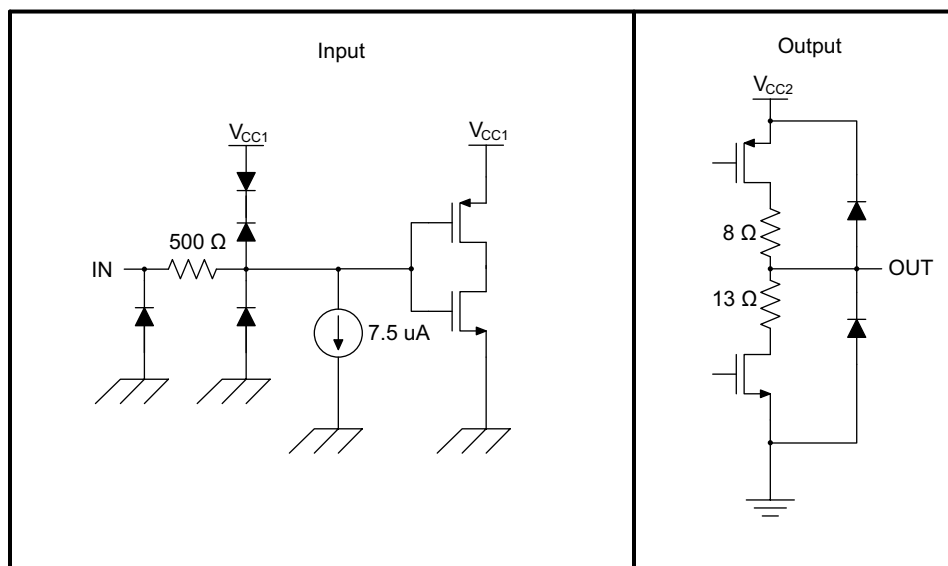

Figure 17. Device I/O Schematics

## 9 Application and Implementation

### NOTE

Information in the following applications sections is not part of the TI component specification, and TI does not warrant its accuracy or completeness. TI's customers are responsible for determining suitability of components for their purposes. Customers should validate and test their design implementation to confirm system functionality.

### 9.1 Application Information

ISO7420FCC utilize single-ended TTL-logic switching technology. Its supply voltage range is from 2.7 V to 5.5 V for both supplies,  $V_{CC1}$  and  $V_{CC2}$ . When designing with digital isolators, it is important to keep in mind that due to the single-ended design structure, digital isolators do not conform to any specific interface standard and are only intended for isolating single-ended CMOS or TTL digital signal lines. The isolator is typically placed between the data controller (i.e.  $\mu\text{C}$  or UART), and a data converter or a line transceiver, regardless of the interface type or standard.

### 9.2 Typical Application

ISO7420FCC can be used to isolate power MOSFETs from sensitive logic circuitry in Switch Mode Power Supplies (SMPS) as shown in Figure 18. Low default output of ISO7420FCC is critical for proper operation of power MOSFETs in such applications.

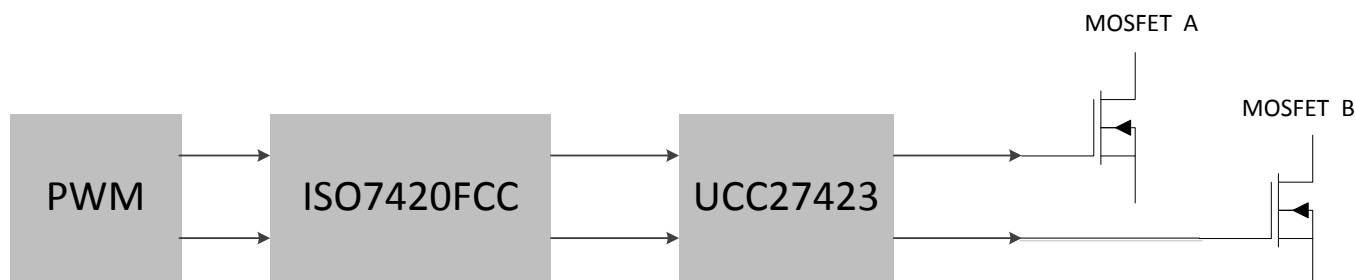

**Figure 18. Isolated Switch Mode Power Supply**

#### 9.2.1 Design Requirements

Unlike optocouplers, which require external components to improve performance, provide bias, or limit current, the ISO7420FCC only requires two external bypass capacitors to operate.

#### 9.2.2 Detailed Design Procedure

##### 9.2.2.1 Supply Current Equations

###### 9.2.2.1.1 Maximum Supply Current Equations

(Calculated over recommended operating temperature range and Silicon process variation).

At  $V_{CC1} = V_{CC2} = 5\text{ V} \pm 10\%$ :

$$I_{CC1}(\text{max}) = 1.1 + 5.80\text{E-}02 \times f \quad (1)$$

$$I_{CC2}(\text{max}) = 4.6 + 6.55\text{E-}02 \times f + 5.5\text{E-}03 \times f \times C_L \quad (2)$$

At  $V_{CC1} = V_{CC2} = 3.3\text{ V} \pm 10\%$ :

$$I_{CC1}(\text{max}) = 0.8 + 3.40\text{E-}02 \times f \quad (3)$$

$$I_{CC2}(\text{max}) = 3.3 + 4.60\text{E-}02 \times f + 3.6\text{E-}03 \times f \times C_L \quad (4)$$

At  $V_{CC1} = V_{CC2} = 2.7\text{ V}$ :

$$I_{CC1}(\text{max}) = 0.4 + 3.20\text{E-}02 \times f \quad (5)$$

$$I_{CC2}(\text{max}) = 3.1 + 3.75\text{E-}02 \times f + 2.7\text{E-}03 \times f \times C_L \quad (6)$$

**Typical Application (continued)**

f is data rate of each channel measured in Mbps;  $C_L$  is the capacitive load of each channel measured in pF;  $I_{CC1(max)}$  and  $I_{CC2(max)}$  are measured in mA.

**9.2.2.1.2 Typical Supply Current Equations**

(Calculated for  $T_A = 25^\circ\text{C}$  and nominal Silicon process material).

At  $V_{CC1} = V_{CC2} = 5\text{ V}$ :

$$I_{CC1(\text{typical})} = 0.5 + 4.40\text{E-}02 \times f \tag{7}$$

$$I_{CC2(\text{typical})} = 3 + 3.50\text{E-}02 \times f + 5.0\text{E-}03 \times f \times C_L \tag{8}$$

At  $V_{CC1} = V_{CC2} = 3.3\text{ V}$ :

$$I_{CC1(\text{typical})} = 0.3 + 2.60\text{E-}02 \times f \tag{9}$$

$$I_{CC2(\text{typical})} = 2.4 + 2.25\text{E-}02 \times f + 3.3\text{E-}03 \times f \times C_L \tag{10}$$

At  $V_{CC1} = V_{CC2} = 2.7\text{ V}$ :

$$I_{CC1(\text{typical})} = 0.15 + 2.10\text{E-}02 \times f \tag{11}$$

$$I_{CC2(\text{typical})} = 2.1 + 1.75\text{E-}02 \times f + 2.7\text{E-}03 \times f \times C_L \tag{12}$$

f is Data Rate of each channel measured in Mbps;  $C_L$  is the Capacitive Load of each channel measured in pF;  $I_{CC1(\text{typ})}$  and  $I_{CC2(\text{typ})}$  are measured in mA.

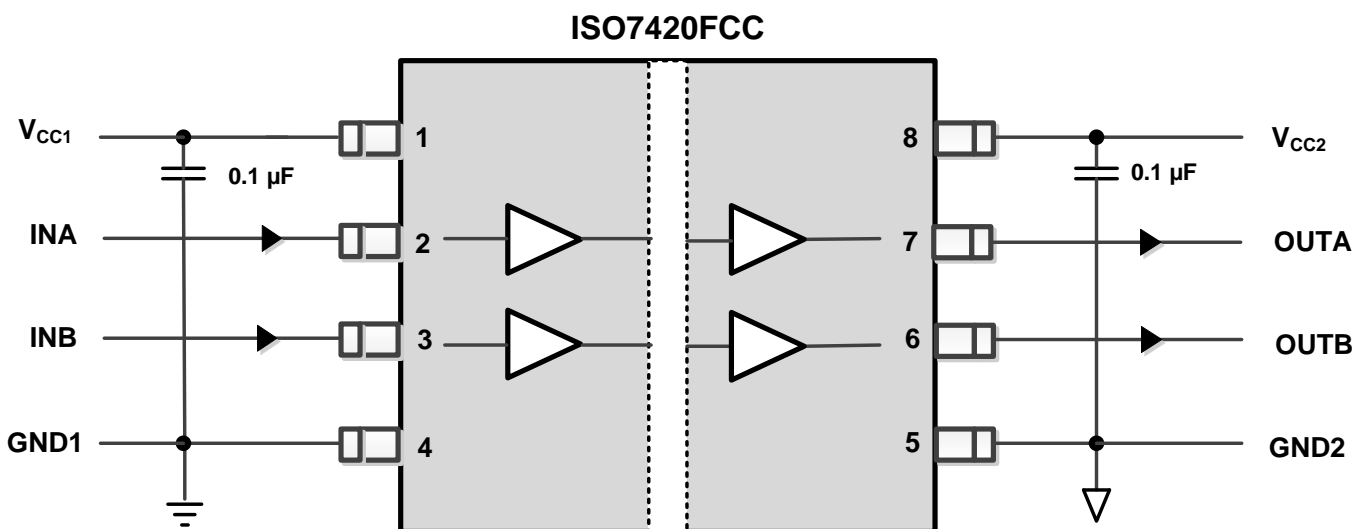
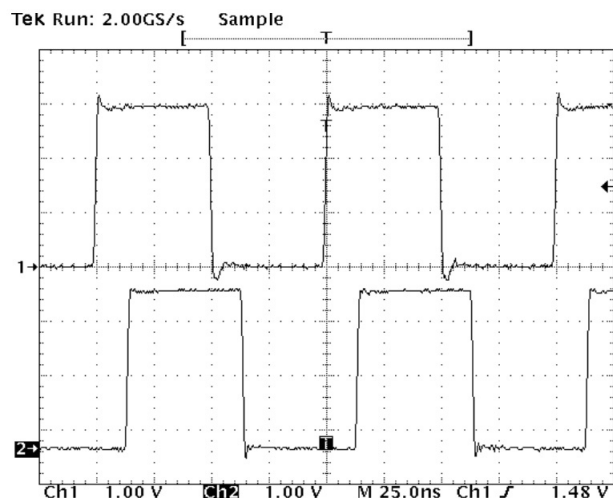

Figure 19. ISO7420FCC Typical Circuit Hook-Up

**Typical Application (continued)**

**9.2.3 Application Curves**

Figure 20 shows the INA input on Channel 1 and OUTA output on Channel 2 of an oscilloscope.



**Figure 20. Typical Input and Output Waveforms**

## 10 Power Supply Recommendations

To ensure reliable operation at all data rates and supply voltages, a 0.1  $\mu\text{F}$  bypass capacitor is recommended at input and output supply pins ( $V_{CC1}$  and  $V_{CC2}$ ). The capacitors should be placed as close to the supply pins as possible. If only a single primary-side power supply is available in an application, isolated power can be generated for the secondary-side with the help of a transformer driver such as Texas Instruments' [SN6501](#). For such applications, detailed power supply design and transformer selection recommendations are available in [SN6501](#) datasheet ([SLLSEA0](#)).

## 11 Layout

### 11.1 Layout Guidelines

A minimum of four layers is required to accomplish a low EMI PCB design (see [Figure 21](#)). Layer stacking should be in the following order (top-to-bottom): high-speed signal layer, ground plane, power plane and low-frequency signal layer.

- Routing the high-speed traces on the top layer avoids the use of vias (and the introduction of their inductances) and allows for clean interconnects between the isolator and the transmitter and receiver circuits of the data link.
- Placing a solid ground plane next to the high-speed signal layer establishes controlled impedance for transmission line interconnects and provides an excellent low-inductance path for the return current flow.
- Placing the power plane next to the ground plane creates additional high-frequency bypass capacitance of approximately  $100\text{pF}/\text{in}^2$ .
- Routing the slower speed control signals on the bottom layer allows for greater flexibility as these signal links usually have margin to tolerate discontinuities such as vias.

If an additional supply voltage plane or signal layer is needed, add a second power / ground plane system to the stack to keep it symmetrical. This makes the stack mechanically stable and prevents it from warping. Also the power and ground plane of each power system can be placed closer together, thus increasing the high-frequency bypass capacitance significantly.

For detailed layout recommendations, see Application Note *Digital Isolator Design Guide*, [SLLA284](#).

#### 11.1.1 PCB Material

For digital circuit boards operating below 150 Mbps, (or rise and fall times higher than 1 ns), and trace lengths of up to 10 inches, use standard FR-4 epoxy-glass as PCB material. FR-4 (Flame Retardant 4) meets the requirements of Underwriters Laboratories UL94-V0, and is preferred over cheaper alternatives due to its lower dielectric losses at high frequencies, less moisture absorption, greater strength and stiffness, and its self-extinguishing flammability-characteristics.

#### 11.2 Layout Example

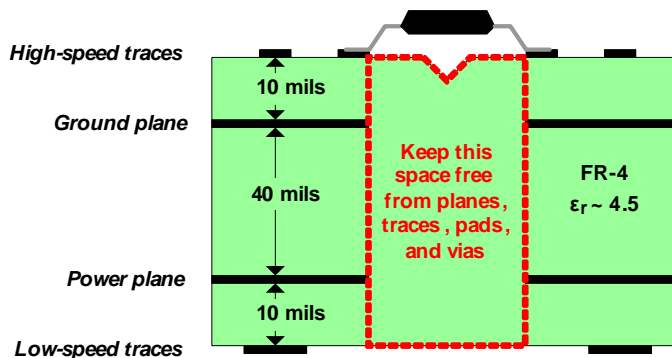

**Figure 21. Recommended Layer Stack**

## 12 Device and Documentation Support

### 12.1 Documentation Support

#### 12.1.1 Related Documentation

For related documentation see the following:

- *SN6501 Transformer Driver for Isolated Power Supplies* ([SLLSEA0](#))
- *LVDS Application and Data Handbook* ([SLLD009](#))
- *Digital Isolator Design Guide* ([SLLA284](#))
- *Isolation Glossary* ([SLLA353](#))

### 12.2 Community Resources

The following links connect to TI community resources. Linked contents are provided "AS IS" by the respective contributors. They do not constitute TI specifications and do not necessarily reflect TI's views; see TI's [Terms of Use](#).

**TI E2E™ Online Community** *TI's Engineer-to-Engineer (E2E) Community*. Created to foster collaboration among engineers. At [e2e.ti.com](http://e2e.ti.com), you can ask questions, share knowledge, explore ideas and help solve problems with fellow engineers.

**Design Support** *TI's Design Support* Quickly find helpful E2E forums along with design support tools and contact information for technical support.

### 12.3 Trademarks

DeviceNet, E2E are trademarks of Texas Instruments.  
All other trademarks are the property of their respective owners.

### 12.4 Electrostatic Discharge Caution



These devices have limited built-in ESD protection. The leads should be shorted together or the device placed in conductive foam during storage or handling to prevent electrostatic damage to the MOS gates.

### 12.5 Glossary

[SLYZ022](#) — *TI Glossary*.

This glossary lists and explains terms, acronyms, and definitions.

## 13 Mechanical, Packaging, and Orderable Information

The following pages include mechanical, packaging, and orderable information. This information is the most current data available for the designated devices. This data is subject to change without notice and revision of this document. For browser-based versions of this data sheet, refer to the left-hand navigation.

**PACKAGING INFORMATION**

Orderable Device	Status (1)	Package Type	Package Drawing	Pins	Package Qty	Eco Plan (2)	Lead/Ball Finish (6)	MSL Peak Temp (3)	Op Temp (°C)	Device Marking (4/5)	Samples
ISO7420FCCD	ACTIVE	SOIC	D	8	75	Green (RoHS & no Sb/Br)	CU NIPDAU	Level-2-260C-1 YEAR	-40 to 125	7420FC	<a href="#">Samples</a>
ISO7420FCCDR	ACTIVE	SOIC	D	8	2500	Green (RoHS & no Sb/Br)	CU NIPDAU	Level-2-260C-1 YEAR	-40 to 125	7420FC	<a href="#">Samples</a>

(1) The marketing status values are defined as follows:

**ACTIVE:** Product device recommended for new designs.

**LIFEBUY:** TI has announced that the device will be discontinued, and a lifetime-buy period is in effect.

**NRND:** Not recommended for new designs. Device is in production to support existing customers, but TI does not recommend using this part in a new design.

**PREVIEW:** Device has been announced but is not in production. Samples may or may not be available.

**OBSELETE:** TI has discontinued the production of the device.

(2) Eco Plan - The planned eco-friendly classification: Pb-Free (RoHS), Pb-Free (RoHS Exempt), or Green (RoHS & no Sb/Br) - please check <http://www.ti.com/productcontent> for the latest availability information and additional product content details.

**TBD:** The Pb-Free/Green conversion plan has not been defined.

**Pb-Free (RoHS):** TI's terms "Lead-Free" or "Pb-Free" mean semiconductor products that are compatible with the current RoHS requirements for all 6 substances, including the requirement that lead not exceed 0.1% by weight in homogeneous materials. Where designed to be soldered at high temperatures, TI Pb-Free products are suitable for use in specified lead-free processes.

**Pb-Free (RoHS Exempt):** This component has a RoHS exemption for either 1) lead-based flip-chip solder bumps used between the die and package, or 2) lead-based die adhesive used between the die and leadframe. The component is otherwise considered Pb-Free (RoHS compatible) as defined above.

**Green (RoHS & no Sb/Br):** TI defines "Green" to mean Pb-Free (RoHS compatible), and free of Bromine (Br) and Antimony (Sb) based flame retardants (Br or Sb do not exceed 0.1% by weight in homogeneous material)

(3) MSL, Peak Temp. - The Moisture Sensitivity Level rating according to the JEDEC industry standard classifications, and peak solder temperature.

(4) There may be additional marking, which relates to the logo, the lot trace code information, or the environmental category on the device.

(5) Multiple Device Markings will be inside parentheses. Only one Device Marking contained in parentheses and separated by a "~" will appear on a device. If a line is indented then it is a continuation of the previous line and the two combined represent the entire Device Marking for that device.

(6) Lead/Ball Finish - Orderable Devices may have multiple material finish options. Finish options are separated by a vertical ruled line. Lead/Ball Finish values may wrap to two lines if the finish value exceeds the maximum column width.

**Important Information and Disclaimer:**The information provided on this page represents TI's knowledge and belief as of the date that it is provided. TI bases its knowledge and belief on information provided by third parties, and makes no representation or warranty as to the accuracy of such information. Efforts are underway to better integrate information from third parties. TI has taken and continues to take reasonable steps to provide representative and accurate information but may not have conducted destructive testing or chemical analysis on incoming materials and chemicals. TI and TI suppliers consider certain information to be proprietary, and thus CAS numbers and other limited information may not be available for release.

In no event shall TI's liability arising out of such information exceed the total purchase price of the TI part(s) at issue in this document sold by TI to Customer on an annual basis.

## TAPE AND REEL INFORMATION



### QUADRANT ASSIGNMENTS FOR PIN 1 ORIENTATION IN TAPE



\*All dimensions are nominal

Device	Package Type	Package Drawing	Pins	SPQ	Reel Diameter (mm)	Reel Width W1 (mm)	A0 (mm)	B0 (mm)	K0 (mm)	P1 (mm)	W (mm)	Pin1 Quadrant
ISO7420FCCDR	SOIC	D	8	2500	330.0	12.4	6.4	5.2	2.1	8.0	12.0	Q1

**TAPE AND REEL BOX DIMENSIONS**



\*All dimensions are nominal

Device	Package Type	Package Drawing	Pins	SPQ	Length (mm)	Width (mm)	Height (mm)
ISO7420FCCDR	SOIC	D	8	2500	350.0	350.0	43.0



D0008A

# PACKAGE OUTLINE

SOIC - 1.75 mm max height

SMALL OUTLINE INTEGRATED CIRCUIT



4214825/C 02/2019

### NOTES:

1. Linear dimensions are in inches [millimeters]. Dimensions in parenthesis are for reference only. Controlling dimensions are in inches. Dimensioning and tolerancing per ASME Y14.5M.
2. This drawing is subject to change without notice.
3. This dimension does not include mold flash, protrusions, or gate burrs. Mold flash, protrusions, or gate burrs shall not exceed  $.006$  [0.15] per side.
4. This dimension does not include interlead flash.
5. Reference JEDEC registration MS-012, variation AA.

# EXAMPLE BOARD LAYOUT

D0008A

SOIC - 1.75 mm max height

SMALL OUTLINE INTEGRATED CIRCUIT



LAND PATTERN EXAMPLE  
 EXPOSED METAL SHOWN  
 SCALE:8X



SOLDER MASK DETAILS

4214825/C 02/2019

NOTES: (continued)

- 6. Publication IPC-7351 may have alternate designs.
- 7. Solder mask tolerances between and around signal pads can vary based on board fabrication site.

# EXAMPLE STENCIL DESIGN

D0008A

SOIC - 1.75 mm max height

SMALL OUTLINE INTEGRATED CIRCUIT



SOLDER PASTE EXAMPLE  
BASED ON .005 INCH [0.125 MM] THICK STENCIL  
SCALE:8X

4214825/C 02/2019

NOTES: (continued)

8. Laser cutting apertures with trapezoidal walls and rounded corners may offer better paste release. IPC-7525 may have alternate design recommendations.
9. Board assembly site may have different recommendations for stencil design.

## IMPORTANT NOTICE AND DISCLAIMER

TI PROVIDES TECHNICAL AND RELIABILITY DATA (INCLUDING DATASHEETS), DESIGN RESOURCES (INCLUDING REFERENCE DESIGNS), APPLICATION OR OTHER DESIGN ADVICE, WEB TOOLS, SAFETY INFORMATION, AND OTHER RESOURCES "AS IS" AND WITH ALL FAULTS, AND DISCLAIMS ALL WARRANTIES, EXPRESS AND IMPLIED, INCLUDING WITHOUT LIMITATION ANY IMPLIED WARRANTIES OF MERCHANTABILITY, FITNESS FOR A PARTICULAR PURPOSE OR NON-INFRINGEMENT OF THIRD PARTY INTELLECTUAL PROPERTY RIGHTS.

These resources are intended for skilled developers designing with TI products. You are solely responsible for (1) selecting the appropriate TI products for your application, (2) designing, validating and testing your application, and (3) ensuring your application meets applicable standards, and any other safety, security, or other requirements. These resources are subject to change without notice. TI grants you permission to use these resources only for development of an application that uses the TI products described in the resource. Other reproduction and display of these resources is prohibited. No license is granted to any other TI intellectual property right or to any third party intellectual property right. TI disclaims responsibility for, and you will fully indemnify TI and its representatives against, any claims, damages, costs, losses, and liabilities arising out of your use of these resources.

TI's products are provided subject to TI's Terms of Sale ([www.ti.com/legal/termsofsale.html](http://www.ti.com/legal/termsofsale.html)) or other applicable terms available either on [ti.com](http://ti.com) or provided in conjunction with such TI products. TI's provision of these resources does not expand or otherwise alter TI's applicable warranties or warranty disclaimers for TI products.

Mailing Address: Texas Instruments, Post Office Box 655303, Dallas, Texas 75265  
Copyright © 2019, Texas Instruments Incorporated

## Looking for pricing, stock, or lifecycle information?

Click below to explore more details on WIN SOURCE:

 [View ISO7420FCCDR](#) on WIN SOURCE

 [Texas Instruments](#) Information

## Optimize Your Supply Chain with WIN SOURCE Solutions

-  Global Sourcing Solution
-  Obsolete Management
-  Cost Control Management
-  Shortage Management
-  Alternative Solution
-  Excess Inventory Management