



One Megabit per Second Triple Digital Isolators

Check for Samples: [ISO7230A](#), [ISO7231A](#)

FEATURES

- 1Mbps Signaling Rate
 - Low Channel-to-Channel Output Skew; 2ns Maximum (5V-Operation)
 - Low Pulse-Width Distortion (PWD); 10ns Maximum (5V-Operation)
- Typical 25-Year Life at Rated Working Voltage (See Application note [SLLA197](#) and [Figure 10](#))
- 4000V_{peak} Isolation, 560V_{peak} V_{IORM}
 - UL 1577, IEC 60747-5-2 (VDE 0884, Rev 2), IE 61010-1 and CSA Approved, IEC 60950-1
- 4kV ESD Protection
- Operate With 3.3V or 5V Supplies
- High Electromagnetic Immunity (See Application note [SLLA181](#))
- –40°C to 125°C Operating Range

APPLICATIONS

- Industrial Fieldbus
- Computer Peripheral Interface
- Servo Control Interface
- Data Acquisition

DESCRIPTION

See the [Product Notification](#) section. The ISO7230A and ISO7231A are triple-channel digital isolators each with multiple channel configurations and output-enable functions. These devices have logic input and output buffers separated by TI's silicon dioxide (SiO₂) isolation barrier. Used in conjunction with isolated power supplies, these devices block high voltage, isolate grounds, and prevent noise currents on a data bus or other circuits from entering the local ground and interfering with or damaging sensitive circuitry.

The ISO7230 triple-channel device has all three channels in the same direction while the ISO7231 has two channels in one direction and one channel in opposition. These devices have an active-high output enable that when driven to a low level, places the output in a high-impedance state.

The ISO7230A and ISO7231A have TTL input thresholds and a noise-filter at the input that prevents transient pulses of up to 2ns in duration from being passed to the output of the device.

In each device a periodic update pulse is sent across the isolation barrier to ensure the proper dc level of the output. If this dc-refresh pulse is not received, the input is assumed to be unpowered or not being actively driven, and the failsafe circuit drives the output to a logic high state. (Contact TI for a logic low failsafe option).

These devices require two supply voltages of 3.3V, 5V, or any combination. All inputs are 5V tolerant when supplied from a 3.3V supply and all outputs are 4mA CMOS. These devices are characterized for operation over the ambient temperature range of –40°C to 125°C.

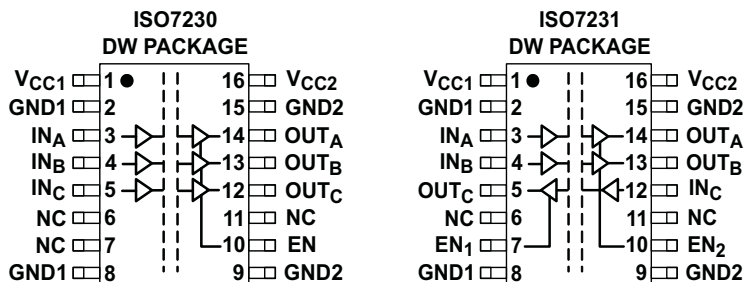

Please be aware that an important notice concerning availability, standard warranty, and use in critical applications of Texas Instruments semiconductor products and disclaimers thereto appears at the end of this data sheet.



This integrated circuit can be damaged by ESD. Texas Instruments recommends that all integrated circuits be handled with appropriate precautions. Failure to observe proper handling and installation procedures can cause damage.

ESD damage can range from subtle performance degradation to complete device failure. Precision integrated circuits may be more susceptible to damage because very small parametric changes could cause the device not to meet its published specifications.

FUNCTION DIAGRAM

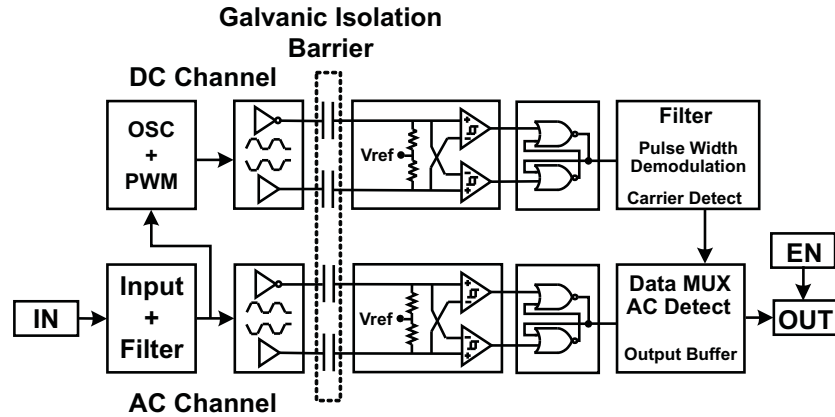

Table 1. Device Function Table ISO723x (1)

INPUT V _{CC}	OUTPUT V _{CC}	INPUT (IN)	OUTPUT ENABLE (EN)	OUTPUT (OUT)
PU	PU	H	H or Open	H
		L	H or Open	L
		X	L	Z
		Open	H or Open	H
PD	PU	X	H or Open	H
PD	PU	X	L	Z

(1) PU = Powered Up; PD = Powered Down ; X = Irrelevant; H = High Level; L = Low Level

AVAILABLE OPTIONS

PRODUCT	SIGNALING RATE	INPUT THRESHOLD	CHANNEL CONFIGURATION	MARKED AS	ORDERING NUMBER ⁽¹⁾
ISO7230ADW	1 Mbps	~1.5V (TTL) (CMOS compatible)	3/0	ISO7230A	ISO7230ADW (rail)
					ISO7230ADWR (reel)
ISO7231ADW	1 Mbps	~1.5 V (TTL) (CMOS compatible)	2/1	ISO7231A	ISO7231ADW (rail)
					ISO7231ADWR (reel)

(1) For the most current package and ordering information, see the Package Option Addendum at the end of this document, or see the TI website at www.ti.com.

ABSOLUTE MAXIMUM RATINGS⁽¹⁾

				VALUE	UNIT
V _{CC}	Supply voltage ⁽²⁾ , V _{CC1} , V _{CC2}			-0.5 to 6	V
V _I	Voltage at IN, OUT, EN			-0.5 to 6	V
I _O	Output current			±15	mA
ESD	Electrostatic discharge	Human Body Model	JEDEC Standard 22, Test Method A114-C.01	All pins	±4
		Field-Induced-Charged Device Model	JEDEC Standard 22, Test Method C101		±1
		Machine Model	ANSI/ESDS5.2-1996		±200
T _J	Maximum junction temperature			170	°C

- (1) Stresses beyond those listed under *absolute maximum ratings* may cause permanent damage to the device. These are stress ratings only and functional operation of the device at these or any other conditions beyond those indicated under *recommended operating conditions* is not implied. Exposure to absolute-maximum-rated conditions for extended periods may affect device reliability.
- (2) All voltage values are with respect to network ground terminal and are peak voltage values.

RECOMMENDED OPERATING CONDITIONS

		MIN	TYP	MAX	UNIT
V _{CC}	Supply voltage ⁽¹⁾ , V _{CC1} , V _{CC2}	3.15		5.5	V
I _{OH}	High-level output current	-4			mA
I _{OL}	Low-level output current			4	mA
t _{ui}	Input pulse width	1			µs
1/t _{ui}	Signaling rate	0	1500 ⁽²⁾	1000	kbps
V _{IH}	High-level input voltage (IN) (EN on all devices)	2		V _{CC}	V
V _{IL}	Low-level input voltage (IN) (EN on all devices)	0		0.8	V
T _J	Junction temperature			150	°C
H	External magnetic field-strength immunity per IEC 61000-4-8 and IEC 61000-4-9 certification			1000	A/m

- (1) For the 5V operation, V_{CC1} or V_{CC2} is specified from 4.5V to 5.5V.
For the 3V operation, V_{CC1} or V_{CC2} is specified from 3.15V to 3.6V.
- (2) Typical signaling rate under ideal conditions at 25°C.

ISO7230A
ISO7231A

SLLS906C –MAY 2008–REVISED JUNE 2011

www.ti.com

ELECTRICAL CHARACTERISTICS: V_{CC1} and V_{CC2} at 5V⁽¹⁾ OPERATION

over recommended operating conditions (unless otherwise noted)

PARAMETER		TEST CONDITIONS		MIN	TYP	MAX	UNIT
SUPPLY CURRENT							
I_{CC1}	ISO7230A	Quiescent	$V_I = V_{CC}$ or 0V, All channels, no load, EN_2 at 3V		1	3	mA
		1 Mbps			1	3	
	ISO7231A	Quiescent	$V_I = V_{CC}$ or 0V, All channels, no load, EN_1 at 3V, EN_2 at 3V		6.5	11	mA
		1 Mbps			6.5	11	
I_{CC2}	ISO7230A	Quiescent	$V_I = V_{CC}$ or 0V, All channels, no load, EN_2 at 3V		15	22	mA
		1 Mbps			16	22	
	ISO7231A	Quiescent	$V_I = V_{CC}$ or 0V, All channels, no load, EN_1 at 3V, EN_2 at 3V		13	20	mA
		1 Mbps			13	20	
ELECTRICAL CHARACTERISTICS							
I_{OFF}	Sleep mode output current	EN at 0V, Single channel			0		μ A
V_{OH}	High-level output voltage	$I_{OH} = -4$ mA, See Figure 1		$V_{CC} - 0.8$			V
		$I_{OH} = -20$ μ A, See Figure 1		$V_{CC} - 0.1$			
V_{OL}	Low-level output voltage	$I_{OL} = 4$ mA, See Figure 1				0.4	V
		$I_{OL} = 20$ μ A, See Figure 1				0.1	
$V_{I(HYS)}$	Input voltage hysteresis				150		mV
I_{IH}	High-level input current	IN from 0V to V_{CC}				10	μ A
I_{IL}	Low-level input current					-10	
C_I	Input capacitance to ground	IN at V_{CC} , $V_I = 0.4 \sin(4E6\pi t)$			2		pF
CMTI	Common-mode transient immunity	$V_I = V_{CC}$ or 0V, See Figure 4		25	50		kV/ μ s

- (1) For the 5V operation, V_{CC1} or V_{CC2} is specified from 4.5V to 5.5V.
For the 3V operation, V_{CC1} or V_{CC2} is specified from 3.15V to 3.6V.

SWITCHING CHARACTERISTICS: V_{CC1} and V_{CC2} at 5V OPERATION

over recommended operating conditions (unless otherwise noted)

PARAMETER		TEST CONDITIONS		MIN	TYP	MAX	UNIT
t_{PLH} , t_{PHL}	Propagation delay	See Figure 1		40		95	ns
PWD	Pulse-width distortion ⁽¹⁾ $ t_{PHL} - t_{PLH} $					10	
$t_{sk(o)}$	Channel-to-channel output skew ⁽²⁾				0	2	ns
t_r	Output signal rise time	See Figure 1			2		ns
t_f	Output signal fall time				2		
t_{PHZ}	Propagation delay, high-level-to-high-impedance output	See Figure 2			15	20	ns
t_{PZH}	Propagation delay, high-impedance-to-high-level output				15	20	
t_{PLZ}	Propagation delay, low-level-to-high-impedance output				15	20	
t_{PZL}	Propagation delay, high-impedance-to-low-level output				15	20	
t_{fs}	Failsafe output delay time from input power loss	See Figure 3			12		μ s

- (1) Also referred to as pulse skew.
(2) $t_{sk(o)}$ is the skew between specified outputs of a single device with all driving inputs connected together and the outputs switching in the same direction while driving identical specified loads.

ELECTRICAL CHARACTERISTICS: V_{CC1} at 5V, V_{CC2} at 3.3V⁽¹⁾ OPERATION

over recommended operating conditions (unless otherwise noted)

PARAMETER		TEST CONDITIONS		MIN	TYP	MAX	UNIT
SUPPLY CURRENT							
I_{CC1}	ISO7230A	Quiescent	$V_I = V_{CC}$ or 0V, All channels, no load, EN ₂ at 3V		1	3	mA
		1 Mbps			1	3	
	ISO7231A	Quiescent	$V_I = V_{CC}$ or 0V, All channels, no load, EN ₁ at 3V, EN ₂ at 3V		6.5	11	mA
		1 Mbps			6.5	11	
I_{CC2}	ISO7230A	Quiescent	$V_I = V_{CC}$ or 0V, All channels, no load, EN ₂ at 3V		9	15	mA
		1 Mbps			9.5	15	
	ISO7231A	Quiescent	$V_I = V_{CC}$ or 0V, All channels, no load, EN ₁ at 3V, EN ₂ at 3V		8	12	mA
		1 Mbps			8	12	
ELECTRICAL CHARACTERISTICS							
I_{OFF}	Sleep mode output current	EN at 0 V, Single channel			0		μA
V_{OH}	High-level output voltage	$I_{OH} = -4\text{mA}$, See Figure 1	ISO7230	$V_{CC} - 0.4$		V	
			ISO7231 (5-V side)	$V_{CC} - 0.8$			
		$I_{OH} = -20\mu\text{A}$, See Figure 1		$V_{CC} - 0.1$			
V_{OL}	Low-level output voltage	$I_{OL} = 4\text{mA}$, See Figure 1		0.4		V	
		$I_{OL} = 20\mu\text{A}$, See Figure 1		0.1			
$V_{I(HYS)}$	Input voltage hysteresis			150		mV	
I_{IH}	High-level input current	IN from 0V to V_{CC}		10		μA	
I_{IL}	Low-level input current			-10			
C_I	Input capacitance to ground	IN at V_{CC} , $V_I = 0.4 \sin(4E6\pi t)$		2		pF	
CMTI	Common-mode transient immunity	$V_I = V_{CC}$ or 0 V, See Figure 4		25	50	kV/μs	

- (1) For the 5-V operation, V_{CC1} or V_{CC2} is specified from 4.5V to 5.5V.
For the 3V operation, V_{CC1} or V_{CC2} is specified from 3.15 V to 3.6 V.

SWITCHING CHARACTERISTICS: V_{CC1} at 5V, V_{CC2} at 3.3V OPERATION

over recommended operating conditions (unless otherwise noted)

PARAMETER		TEST CONDITIONS	MIN	TYP	MAX	UNIT
t_{PLH} , t_{PHL}	Propagation delay, low-to-high-level output	See Figure 1	40		100	ns
PWD	Pulse-width distortion ⁽¹⁾ $ t_{PHL} - t_{PLH} $				11	
$t_{sk(o)}$	Channel-to-channel output skew ⁽²⁾	ISO723xA		0	2.5	ns
t_r	Output signal rise time	See Figure 1			2	ns
t_f	Output signal fall time				2	
t_{PHZ}	Propagation delay, high-level-to-high-impedance output	See Figure 2			15	ns
t_{PZH}	Propagation delay, high-impedance-to-high-level output				15	
t_{PLZ}	Propagation delay, low-level-to-high-impedance output				15	
t_{PZL}	Propagation delay, high-impedance-to-low-level output				15	
t_{fs}	Failsafe output delay time from input power loss	See Figure 3			18	μs

- (1) Also known as pulse skew
(2) $t_{sk(o)}$ is the skew between specified outputs of a single device with all driving inputs connected together and the outputs switching in the same direction while driving identical specified loads.

ISO7230A
ISO7231A

SLLS906C –MAY 2008–REVISED JUNE 2011

www.ti.com

ELECTRICAL CHARACTERISTICS: V_{CC1} at 3.3V, V_{CC2} at 5V⁽¹⁾ OPERATION

over recommended operating conditions (unless otherwise noted)

PARAMETER		TEST CONDITIONS		MIN	TYP	MAX	UNIT
SUPPLY CURRENT							
I_{CC1}	ISO7230A	Quiescent	$V_I = V_{CC}$ or 0V, All channels, no load, EN ₂ at 3V	0.5	1	1	mA
		1 Mbps					
	ISO7231A	Quiescent		4.5	7	7	
		1 Mbps					
I_{CC2}	ISO7230A	Quiescent	$V_I = V_{CC}$ or 0V, All channels, no load, EN ₂ at 3V	15	22	22	mA
		1 Mbps					
	ISO7231A	Quiescent		13	20	20	
		1 Mbps					
ELECTRICAL CHARACTERISTICS							
I_{OFF}	Sleep mode output current	EN at 0V, Single channel		0			μA
V_{OH}	High-level output voltage	$I_{OH} = -4mA$, See Figure 1	ISO7230	$V_{CC} - 0.4$		V	
			ISO7231 (5-V side)	$V_{CC} - 0.8$			
		$I_{OH} = -20\mu A$, See Figure 1	$V_{CC} - 0.1$				
V_{OL}	Low-level output voltage	$I_{OL} = 4mA$, See Figure 1		0.4		V	
		$I_{OL} = 20\mu A$, See Figure 1		0.1			
$V_{I(HYS)}$	Input voltage hysteresis			150		mV	
I_{IH}	High-level input current	IN from 0V to V_{CC}		10		μA	
I_{IL}	Low-level input current						
C_I	Input capacitance to ground	IN at V_{CC} , $V_I = 0.4 \sin(4E6\pi t)$		2		pF	
CMTI	Common-mode transient immunity	$V_I = V_{CC}$ or 0V, See Figure 4		25	50	kV/μs	

- (1) For 5V operation, V_{CC1} or V_{CC2} is specified from 4.5V to 5.5V.
For 3V operation, V_{CC1} or V_{CC2} is specified from 3.15V to 3.6V.

SWITCHING CHARACTERISTICS: V_{CC1} at 3.3V and V_{CC2} at 5V OPERATION

over recommended operating conditions (unless otherwise noted)

PARAMETER		TEST CONDITIONS		MIN	TYP	MAX	UNIT
t_{PLH}, t_{PHL}	Propagation delay	ISO723xA	See Figure 1	40	100	11	ns
PWD	Pulse-width distortion ⁽¹⁾ $ t_{PHL} - t_{PLH} $						
$t_{sk(o)}$	Channel-to-channel output skew ⁽²⁾	ISO723xA		0	2.5		ns
t_r	Output signal rise time	See Figure 1		2		2	ns
t_f	Output signal fall time						
t_{PHZ}	Propagation delay, high-level-to-high-impedance output	See Figure 2		15		20	
t_{PZH}	Propagation delay, high-impedance-to-high-level output						
t_{PLZ}	Propagation delay, low-level-to-high-impedance output						
t_{PZL}	Propagation delay, high-impedance-to-low-level output						
t_{fs}	Failsafe output delay time from input power loss	See Figure 3		12			μs

- (1) Also known as pulse skew
(2) $t_{sk(o)}$ is the skew between specified outputs of a single device with all driving inputs connected together and the outputs switching in the same direction while driving identical specified loads.

ELECTRICAL CHARACTERISTICS: V_{CC1} and V_{CC2} at 3.3V⁽¹⁾ OPERATION

over recommended operating conditions (unless otherwise noted)

PARAMETER		TEST CONDITIONS		MIN	TYP	MAX	UNIT
SUPPLY CURRENT							
I_{CC1}	ISO7230A	Quiescent	$V_I = V_{CC}$ or 0 V, all channels, no load, EN_2 at 3V	0.5	1		mA
		1 Mbps		1	2		
	ISO7231A	Quiescent	$V_I = V_{CC}$ or 0V, all channels, no load, EN_1 at 3V, EN_2 at 3V	4.5	7		mA
		1 Mbps		4.5	7		
I_{CC2}	ISO7230A	Quiescent	$V_I = V_{CC}$ or 0V, all channels, no load, EN_2 at 3V	9	15		mA
		1 Mbps		9.5	15		
	ISO7231A	Quiescent	$V_I = V_{CC}$ or 0V, all channels, no load, EN_1 at 3V, EN_2 at 3V	8	12		mA
		1 Mbps		8	12		
ELECTRICAL CHARACTERISTICS							
I_{OFF}	Sleep mode output current	EN at 0V, single channel		0			μ A
V_{OH}	High-level output voltage	$I_{OH} = -4$ mA, See Figure 1		$V_{CC} - 0.4$			V
		$I_{OH} = -20$ μ A, See Figure 1		$V_{CC} - 0.1$			
V_{OL}	Low-level output voltage	$I_{OL} = 4$ mA, See Figure 1				0.4	V
		$I_{OL} = 20$ μ A, See Figure 1				0.1	
$V_{I(HYS)}$	Input voltage hysteresis			150			mV
I_{IH}	High-level input current	IN from 0V or V_{CC}				10	μ A
I_{IL}	Low-level input current			-10			
C_I	Input capacitance to ground	IN at V_{CC} , $V_I = 0.4 \sin(4E6\pi t)$				2	pF
CMTI	Common-mode transient immunity	$V_I = V_{CC}$ or 0V, See Figure 4		25	50		kV/ μ s

- (1) For 5V operation, V_{CC1} or V_{CC2} is specified from 4.5V to 5.5V.
For 3V operation, V_{CC1} or V_{CC2} is specified from 3.15V to 3.6V.

SWITCHING CHARACTERISTICS: V_{CC1} and V_{CC2} at 3.3-V OPERATION

over recommended operating conditions (unless otherwise noted)

PARAMETER		TEST CONDITIONS		MIN	TYP	MAX	UNIT
t_{PLH} , t_{PHL}	Propagation delay	ISO723xA	See Figure 1	45		110	ns
PWD	Pulse-width distortion ⁽¹⁾ $ t_{PHL} - t_{PLH} $				12		
$t_{sk(o)}$	Channel-to-channel output skew ⁽²⁾	ISO723xA			0	3	ns
t_r	Output signal rise time	See Figure 1				2	ns
t_f	Output signal fall time			2			
t_{PHZ}	Propagation delay, high-level-to-high-impedance output	See Figure 2				15	ns
t_{PZH}	Propagation delay, high-impedance-to-high-level output			15		20	
t_{PLZ}	Propagation delay, low-level-to-high-impedance output			15		20	
t_{PZL}	Propagation delay, high-impedance-to-low-level output			15		20	
t_{fs}	Failsafe output delay time from input power loss	See Figure 3				18	μ s

- (1) Also referred to as pulse skew.
(2) $t_{sk(o)}$ is the skew between specified outputs of a single device with all driving inputs connected together and the outputs switching in the same direction while driving identical specified loads.

PARAMETER MEASUREMENT INFORMATION

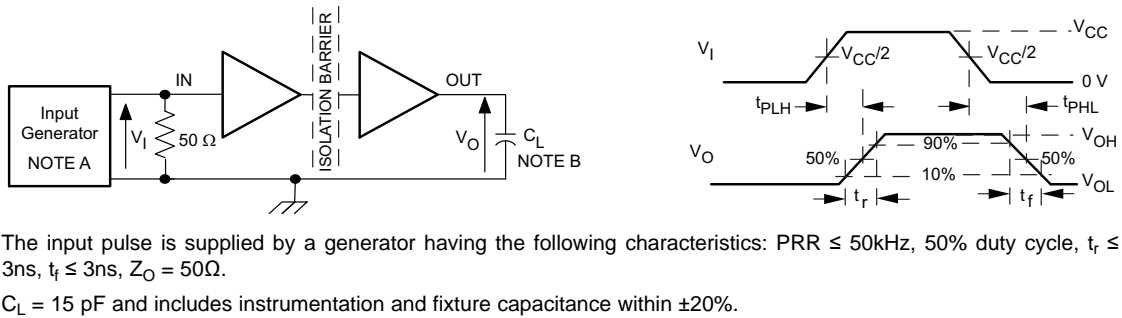

Figure 1. Switching Characteristic Test Circuit and Voltage Waveforms

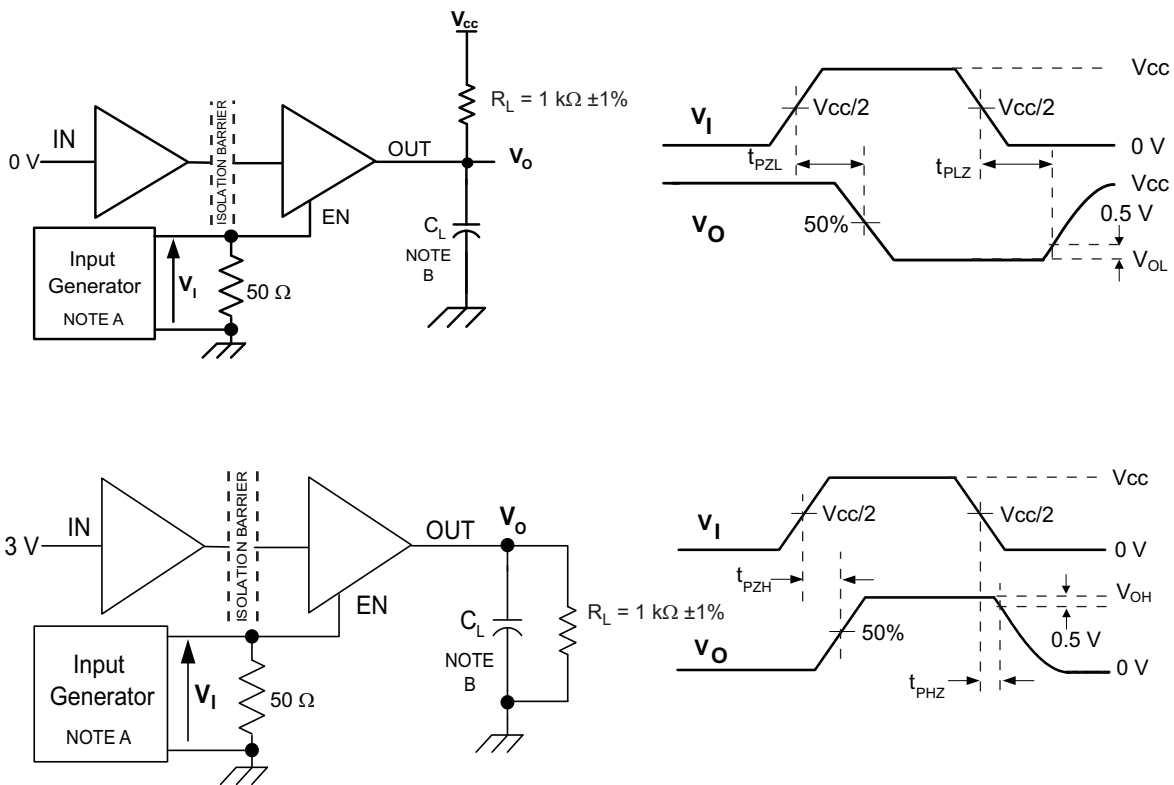
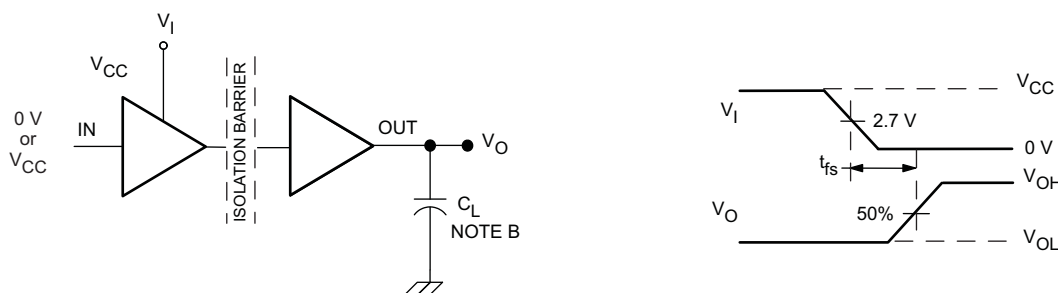

Figure 2. Enable/Disable Propagation Delay Time Test Circuit and Waveform

PARAMETER MEASUREMENT INFORMATION (continued)



- A. The input pulse is supplied by a generator having the following characteristics: PRR \leq 50kHz, 50% duty cycle, $t_r \leq$ 3ns, $t_f \leq$ 3ns, $Z_O = 50\Omega$.
- B. $C_L = 15\text{pF}$ and includes instrumentation and fixture capacitance within $\pm 20\%$.

Figure 3. Failsafe Delay Time Test Circuit and Voltage Waveforms

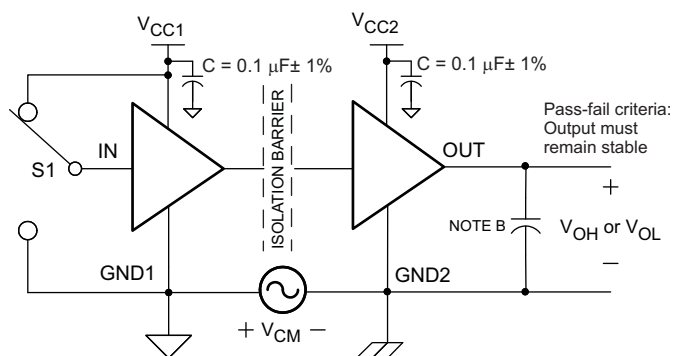

- A. The input pulse is supplied by a generator having the following characteristics: PRR \leq 50kHz, 50% duty cycle, $t_r \leq$ 3ns, $t_f \leq$ 3ns, $Z_O = 50\Omega$.
- B. $C_L = 15\text{pF}$ and includes instrumentation and fixture capacitance within $\pm 20\%$.

Figure 4. Common-Mode Transient Immunity Test Circuit and Voltage Waveform

DEVICE INFORMATION

PACKAGE CHARACTERISTICS

PARAMETER	TEST CONDITIONS	MIN	TYP	MAX	UNIT
L(I01) Minimum air gap (Clearance)	Shortest terminal-to-terminal distance through air	8.34			mm
L(I02) Minimum external tracking (Creepage)	Shortest terminal-to-terminal distance across the package surface	8.1			mm
Minimum Internal Gap (Internal Clearance)	Distance through the insulation	0.008			mm
R _{IO} Isolation resistance	Input to output, V _{IO} = 500V, all pins on each side of the barrier tied together creating a two-terminal device, T _A < 100°C		>10 ¹²		Ω
	Input to output, V _{IO} = 500V, 100°C ≤ T _A ≤ T _A max		>10 ¹¹		Ω
C _{IO} Barrier capacitance Input to output	V _I = 0.4 sin (4E6πt)		2		pF
C _I Input capacitance to ground	V _I = 0.4 sin (4E6πt)		2		pF

REGULATORY INFORMATION

VDE	CSA	UL
Certified according to IEC 60747-5-2	Approved under CSA Component Acceptance Notice	Recognized under 1577 Component Recognition Program ⁽¹⁾
File Number: 40016131	File Number: 220991	File Number: E181974

(1) Production tested ≥ 3000 VRMS for 1 second in accordance with UL 1577.

DEVICE I/O SCHEMATICS

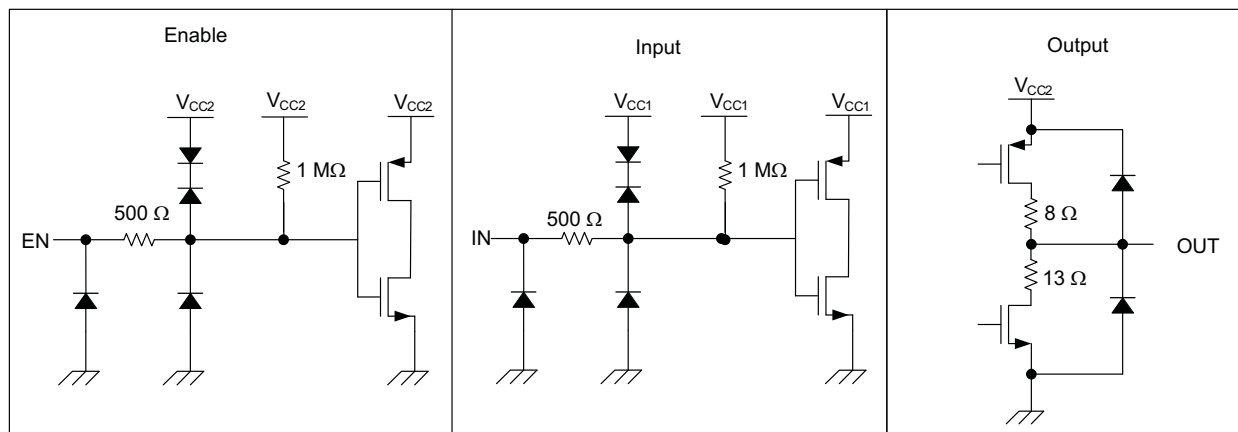

THERMAL CHARACTERISTICS

over recommended operating conditions (unless otherwise noted)

PARAMETER		TEST CONDITIONS	MIN	TYP	MAX	UNIT
θ_{JA}	Junction-to-air	Low-K Thermal Resistance ⁽¹⁾		168		°C/W
		High-K Thermal Resistance		96.1		
θ_{JB}	Junction-to-Board Thermal Resistance			61		°C/W
θ_{JC}	Junction-to-Case Thermal Resistance			48		°C/W
P_D	Device Power Dissipation	$V_{CC1} = V_{CC2} = 5.5\text{ V}$, $T_J = 150^\circ\text{C}$, $C_L = 15\text{ pF}$, Input a 50% duty cycle square wave			220	mW

(1) Tested in accordance with the Low-K or High-K thermal metric definitions of EIA/JESD51-3 for leaded surface mount packages.

TYPICAL CHARACTERISTIC CURVES

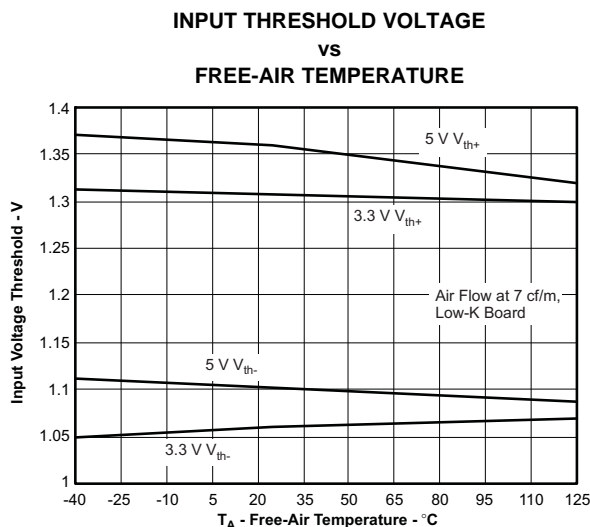

Figure 5.

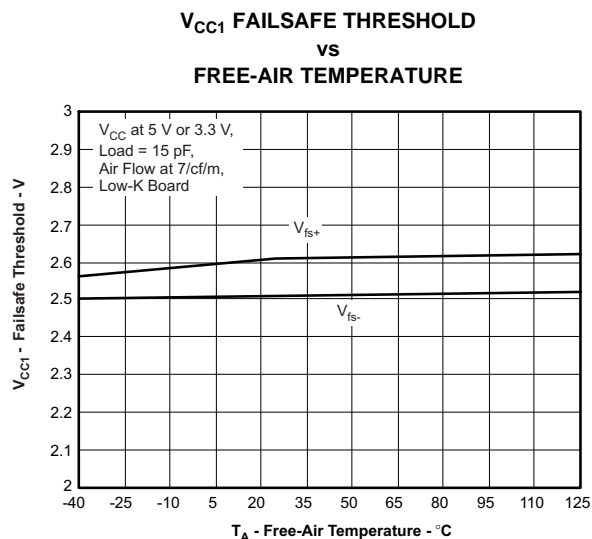

Figure 6.

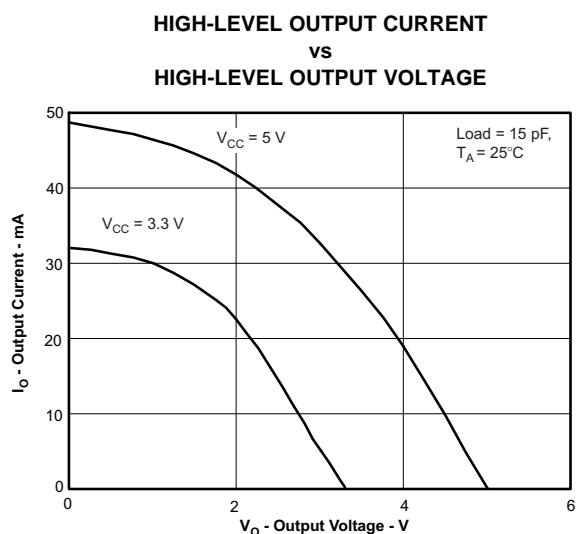

Figure 7.

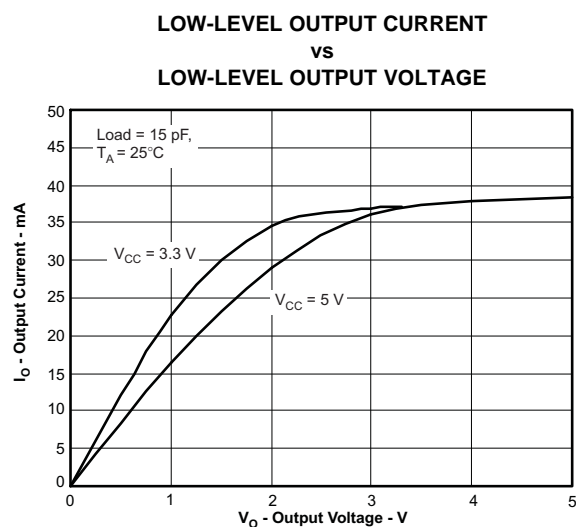

Figure 8.

APPLICATION INFORMATION

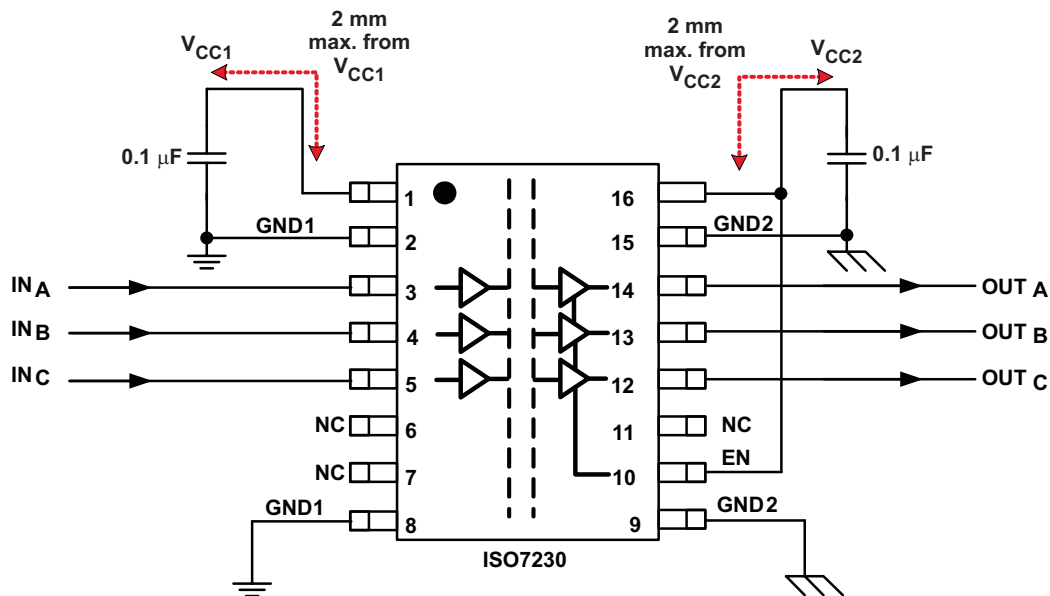

Figure 9. Typical ISO7230 Application Circuit

LIFE EXPECTANCY vs WORKING VOLTAGE

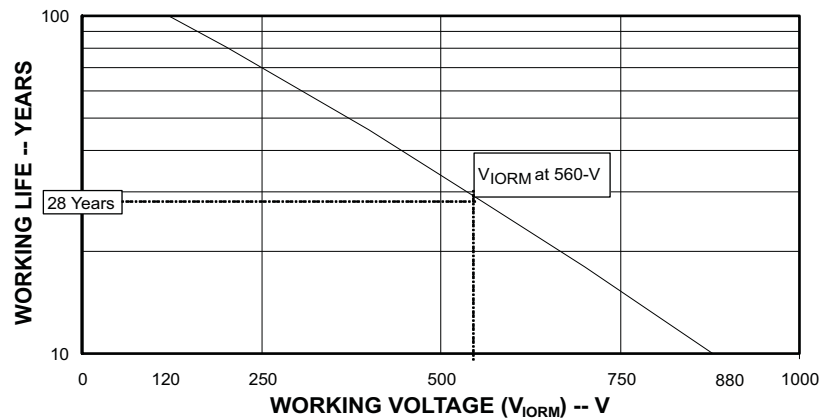

Figure 10. Time Dependant Dielectric Breakdown Testing Results

PRODUCT NOTIFICATION

An ISO723xA anomaly occurs when a negative-going pulse below the specified 1 μ s minimum bit width is input to the device. The output locks in a logic-low condition until the next rising edge occurs after a 1 μ s period.

Positive noise edges in pulses of less than the minimum specified 1 μ s have no effect on the device, and are properly filtered.

To prevent noise from interfering with ISO723xA performance, it is recommended that an appropriately sized capacitor be placed on each input of the device

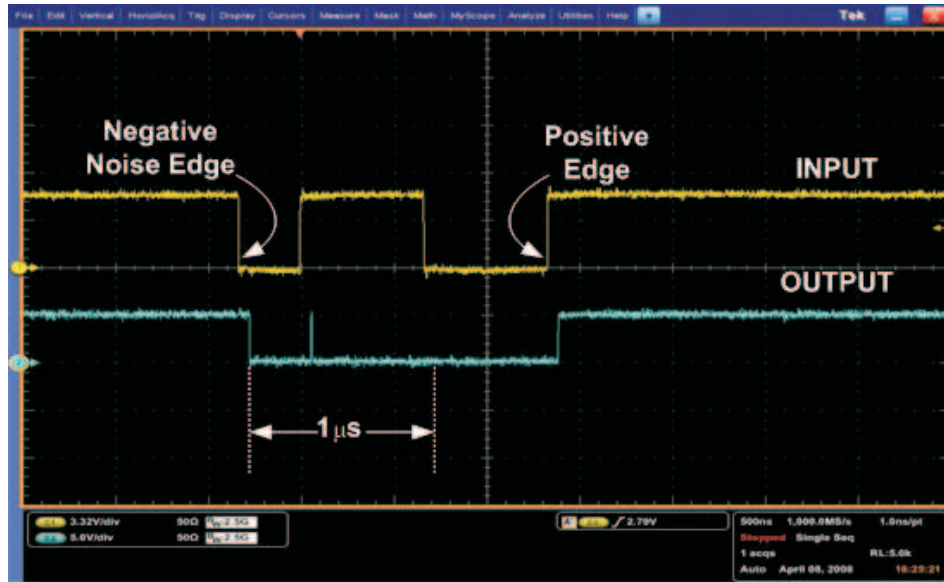

Figure 11. ISO723xA Anomaly

REVISION HISTORY

Changes from Original (May 2008) to Revision A	Page
• Added Product Notification section link.	1
• Deleted text from paragraph 2 of the Description: "and turns off internal bias circuitry to conserve power"	1
• Deleted Product Preview note	2
• Changed From: 3 To: 3.15	3
• Changed V_{CC} From: 3.6 To: 3.45	3
• Changed I_{CC1} and I_{CC2} values From: TBD	4
• Changed $V_{CC} - 0.4$ To: $V_{CC} - 0.8$	4
• Changed Typical value from 1 To: 2	4
• Changed Propagation delay max From: 80 To: 95	4
• Changed I_{CC1} and I_{CC2} values From: TBD	5
• Changed Typical value from 1 To: 2	5
• Changed Propagation delay max From: 80 To: 100	5
• Changed I_{CC1} and I_{CC2} values From: TBD	6
• Changed Typical value from 1 To: 2	6
• Changed Propagation delay max From: 80 To: 100	6
• Changed I_{CC1} and I_{CC2} values From: TBD	7
• Changed	7
• Changed Typical value from 1 To: 2	7
• Changed Propagation delay max From: 85 To: 110	7
• Changed L(101) Minimum air gap (Clearance) - minimum value from: 7.7mm to: 8.34mm	10
• Changed Typical value from 1 To: 2	10
• Changed Typical value from 1 To: 2	10
• Changed the REGULATORY INFORMATION Table	10
• Changed Figure 11	13

Changes from Revision A (June 2008) to Revision B	Page
• Changed V_{CC} From: 3.45 To: 3.6	3

Changes from Revision B (July 2008) to Revision C	Page
• Changed "1ns" to "2ns", added "(5v-Operation)"	1
• Changed "2ns" to "10ns", added "(5v-Operation)"	1
• Deleted "Low Jitter Content; 1 ns Typ at 150 Mbps"	1
• Deleted Min = 4.5 V and max = 5.5 V for Supply Voltage of the ROC Table.	3
• Changed V_{CC} From: 3.6 To: 5.5	3
• Corrected Figure 1	8
• Changed File number "1698195" to "220991"	10
• Corrected DEVICE I/O SCHEMATICS	10
• Corrected Figure 9	12

PACKAGING INFORMATION

Orderable Device	Status (1)	Package Type	Package Drawing	Pins	Package Qty	Eco Plan (2)	Lead finish/ Ball material (6)	MSL Peak Temp (3)	Op Temp (°C)	Device Marking (4/5)	Samples
ISO7230ADW	LIFEBUY	SOIC	DW	16	40	RoHS & Green	NIPDAU	Level-2-260C-1 YEAR	-40 to 125	ISO7230A	
ISO7230ADWR	LIFEBUY	SOIC	DW	16	2000	RoHS & Green	NIPDAU	Level-2-260C-1 YEAR	-40 to 125	ISO7230A	
ISO7231ADW	LIFEBUY	SOIC	DW	16	40	RoHS & Green	NIPDAU	Level-2-260C-1 YEAR	-40 to 125	ISO7231A	
ISO7231ADWR	LIFEBUY	SOIC	DW	16	2000	RoHS & Green	NIPDAU	Level-2-260C-1 YEAR	-40 to 125	ISO7231A	

(1) The marketing status values are defined as follows:

ACTIVE: Product device recommended for new designs.

LIFEBUY: TI has announced that the device will be discontinued, and a lifetime-buy period is in effect.

NRND: Not recommended for new designs. Device is in production to support existing customers, but TI does not recommend using this part in a new design.

PREVIEW: Device has been announced but is not in production. Samples may or may not be available.

OBSOLETE: TI has discontinued the production of the device.

(2) **RoHS:** TI defines "RoHS" to mean semiconductor products that are compliant with the current EU RoHS requirements for all 10 RoHS substances, including the requirement that RoHS substance do not exceed 0.1% by weight in homogeneous materials. Where designed to be soldered at high temperatures, "RoHS" products are suitable for use in specified lead-free processes. TI may reference these types of products as "Pb-Free".

RoHS Exempt: TI defines "RoHS Exempt" to mean products that contain lead but are compliant with EU RoHS pursuant to a specific EU RoHS exemption.

Green: TI defines "Green" to mean the content of Chlorine (Cl) and Bromine (Br) based flame retardants meet JS709B low halogen requirements of <=1000ppm threshold. Antimony trioxide based flame retardants must also meet the <=1000ppm threshold requirement.

(3) MSL, Peak Temp. - The Moisture Sensitivity Level rating according to the JEDEC industry standard classifications, and peak solder temperature.

(4) There may be additional marking, which relates to the logo, the lot trace code information, or the environmental category on the device.

(5) Multiple Device Markings will be inside parentheses. Only one Device Marking contained in parentheses and separated by a "~" will appear on a device. If a line is indented then it is a continuation of the previous line and the two combined represent the entire Device Marking for that device.

(6) Lead finish/Ball material - Orderable Devices may have multiple material finish options. Finish options are separated by a vertical ruled line. Lead finish/Ball material values may wrap to two lines if the finish value exceeds the maximum column width.

Important Information and Disclaimer:The information provided on this page represents TI's knowledge and belief as of the date that it is provided. TI bases its knowledge and belief on information provided by third parties, and makes no representation or warranty as to the accuracy of such information. Efforts are underway to better integrate information from third parties. TI has taken and continues to take reasonable steps to provide representative and accurate information but may not have conducted destructive testing or chemical analysis on incoming materials and chemicals. TI and TI suppliers consider certain information to be proprietary, and thus CAS numbers and other limited information may not be available for release.

In no event shall TI's liability arising out of such information exceed the total purchase price of the TI part(s) at issue in this document sold by TI to Customer on an annual basis.

TAPE AND REEL INFORMATION

QUADRANT ASSIGNMENTS FOR PIN 1 ORIENTATION IN TAPE

*All dimensions are nominal

Device	Package Type	Package Drawing	Pins	SPQ	Reel Diameter (mm)	Reel Width W1 (mm)	A0 (mm)	B0 (mm)	K0 (mm)	P1 (mm)	W (mm)	Pin1 Quadrant
ISO7230ADWR	SOIC	DW	16	2000	330.0	16.4	10.75	10.7	2.7	12.0	16.0	Q1
ISO7231ADWR	SOIC	DW	16	2000	330.0	16.4	10.75	10.7	2.7	12.0	16.0	Q1

TAPE AND REEL BOX DIMENSIONS

*All dimensions are nominal

Device	Package Type	Package Drawing	Pins	SPQ	Length (mm)	Width (mm)	Height (mm)
ISO7230ADWR	SOIC	DW	16	2000	350.0	350.0	43.0
ISO7231ADWR	SOIC	DW	16	2000	350.0	350.0	43.0

TUBE

*All dimensions are nominal

Device	Package Name	Package Type	Pins	SPQ	L (mm)	W (mm)	T (μm)	B (mm)
ISO7230ADW	DW	SOIC	16	40	506.98	12.7	4826	6.6
ISO7231ADW	DW	SOIC	16	40	506.98	12.7	4826	6.6

GENERIC PACKAGE VIEW

DW 16

SOIC - 2.65 mm max height

7.5 x 10.3, 1.27 mm pitch

SMALL OUTLINE INTEGRATED CIRCUIT

This image is a representation of the package family, actual package may vary.
Refer to the product data sheet for package details.

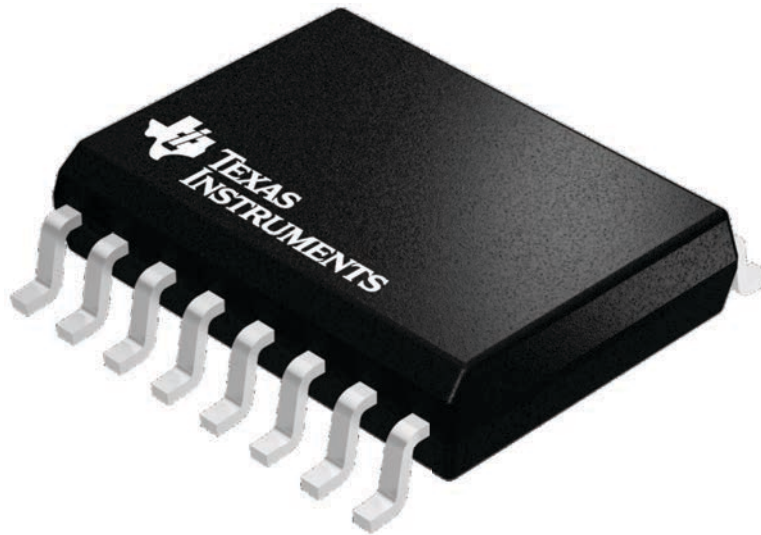

4224780/A

IMPORTANT NOTICE AND DISCLAIMER

TI PROVIDES TECHNICAL AND RELIABILITY DATA (INCLUDING DATA SHEETS), DESIGN RESOURCES (INCLUDING REFERENCE DESIGNS), APPLICATION OR OTHER DESIGN ADVICE, WEB TOOLS, SAFETY INFORMATION, AND OTHER RESOURCES "AS IS" AND WITH ALL FAULTS, AND DISCLAIMS ALL WARRANTIES, EXPRESS AND IMPLIED, INCLUDING WITHOUT LIMITATION ANY IMPLIED WARRANTIES OF MERCHANTABILITY, FITNESS FOR A PARTICULAR PURPOSE OR NON-INFRINGEMENT OF THIRD PARTY INTELLECTUAL PROPERTY RIGHTS.

These resources are intended for skilled developers designing with TI products. You are solely responsible for (1) selecting the appropriate TI products for your application, (2) designing, validating and testing your application, and (3) ensuring your application meets applicable standards, and any other safety, security, regulatory or other requirements.

These resources are subject to change without notice. TI grants you permission to use these resources only for development of an application that uses the TI products described in the resource. Other reproduction and display of these resources is prohibited. No license is granted to any other TI intellectual property right or to any third party intellectual property right. TI disclaims responsibility for, and you will fully indemnify TI and its representatives against, any claims, damages, costs, losses, and liabilities arising out of your use of these resources.

TI's products are provided subject to [TI's Terms of Sale](#) or other applicable terms available either on [ti.com](https://www.ti.com) or provided in conjunction with such TI products. TI's provision of these resources does not expand or otherwise alter TI's applicable warranties or warranty disclaimers for TI products.

TI objects to and rejects any additional or different terms you may have proposed.

Mailing Address: Texas Instruments, Post Office Box 655303, Dallas, Texas 75265
Copyright © 2024, Texas Instruments Incorporated

Looking for pricing, stock, or lifecycle information?

Click below to explore more details on WIN SOURCE:

 [View ISO7230ADWR](#) on WIN SOURCE

 [Texas Instruments](#) Information

Optimize Your Supply Chain with WIN SOURCE Solutions

-  Global Sourcing Solution
-  Obsolete Management
-  Cost Control Management
-  Shortage Management
-  Alternative Solution
-  Excess Inventory Management