



# THE DATASHEET OF ISO7220ADRG4



## ISO722x Dual-Channel Digital Isolators

### 1 Features

- 1, 5, 25, and 150-Mbps Signaling Rate Options
  - Low Channel-to-Channel Output Skew; 1-ns Max
  - Low Pulse-Width Distortion (PWD); 1-ns Max
  - Low Jitter Content; 1 ns Typ at 150 Mbps
- 50 kV/μs Typical Transient Immunity
- Operates with 2.8-V (C-Grade), 3.3-V, or 5-V Supplies
- 4-kV ESD Protection
- High Electromagnetic Immunity
- –40°C to +125°C Operating Range
- Typical 28-Year Life at Rated Voltage  
(see [High-Voltage Lifetime of the ISO72x Family of Digital Isolators](#) and [Isolation Capacitor Lifetime Projection](#))
- Safety-Related Certifications
  - VDE Basic Insulation with 4000-V<sub>PK</sub> V<sub>IOTM</sub>, 560 V<sub>PK</sub> V<sub>IORM</sub> per DIN VDE V 0884-11:2017-01 and DIN EN 61010-1 (VDE 0411-1)
  - 2500 V<sub>RMS</sub> Isolation per UL 1577
  - CSA Approved for IEC 60950-1 and IEC 62368-1

### 2 Applications

- Industrial Fieldbus
  - Modbus
  - Profibus™
  - DeviceNet™ Data Buses
- Computer Peripheral Interface
- Servo Control Interface
- Data Acquisition

### 3 Description

The ISO7220x and ISO7221x family devices are dual-channel digital isolators. To facilitate PCB layout, the channels are oriented in the same direction in the ISO7220x and in opposite directions in the ISO7221x. These devices have a logic input and output buffer separated by TI's silicon-dioxide (SiO<sub>2</sub>) isolation barrier, providing galvanic isolation of up to 4000 V<sub>PK</sub> per VDE. Used in conjunction with isolated power supplies, these devices block high voltage and isolate grounds, as well as prevent noise currents on a data bus or other circuits from entering the local ground and interfering with or damaging sensitive circuitry.

A binary input signal is conditioned, translated to a balanced signal, then differentiated by the capacitive isolation barrier. Across the isolation barrier, a differential comparator receives the logic transition information, then sets or resets a flip-flop and the output circuit accordingly. A periodic update pulse is sent across the barrier to ensure the proper dc level of the output. If this dc-refresh pulse is not received every 4 μs, the input is assumed to be unpowered or not being actively driven, and the failsafe circuit drives the output to a logic high state.

The small capacitance and resulting time constant provide fast operation with signaling rates available from 0 Mbps (DC) to 150 Mbps (The signaling rate of a line is the number of voltage transitions that are made per second expressed in the units bps). The A-option, B-option, and C-option devices have TTL input thresholds and a noise filter at the input that prevents transient pulses from being passed to the output of the device. The M-option devices have CMOS V<sub>CC</sub>/2 input thresholds and do not have the input noise filter and the additional propagation delay.

The ISO7220x and ISO7221x family of devices require two supply voltages of 2.8 V (C-Grade), 3.3 V, 5 V, or any combination. All inputs are 5-V tolerant when supplied from a 2.8-V or 3.3-V supply and all outputs are 4-mA CMOS.

The ISO7220x and ISO7221x family of devices are characterized for operation over the ambient temperature range of –40°C to +125°C.

#### Device Information<sup>(1)</sup>

PART NUMBER	PACKAGE	BODY SIZE (NOM)
ISO7220x	SOIC (8)	4.90 mm x 3.91 mm
ISO7221x		

(1) For all available packages, see the orderable addendum at the end of the data sheet.

#### Simplified Schematic

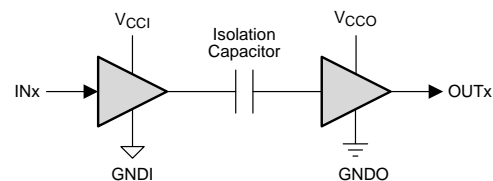

V<sub>CCI</sub> and GNDI are supply and ground connections respectively for the input channels.

V<sub>CCO</sub> and GNDO are supply and ground connections respectively for the output channels.



## Table of Contents

<b>1 Features</b> .....	<b>1</b>	Supplies .....	<b>17</b>
<b>2 Applications</b> .....	<b>1</b>	6.18 Switching Characteristics—2.8-V $V_{CC1}$ and $V_{CC2}$ Supplies .....	<b>17</b>
<b>3 Description</b> .....	<b>1</b>	6.19 Insulation Characteristics Curves .....	<b>18</b>
<b>4 Revision History</b> .....	<b>2</b>	6.20 Typical Characteristics .....	<b>19</b>
<b>5 Pin Configuration and Functions</b> .....	<b>6</b>	<b>7 Parameter Measurement Information</b> .....	<b>21</b>
<b>6 Specifications</b> .....	<b>6</b>	<b>8 Detailed Description</b> .....	<b>23</b>
6.1 Absolute Maximum Ratings .....	<b>6</b>	8.1 Overview .....	<b>23</b>
6.2 ESD Ratings .....	<b>6</b>	8.2 Functional Block Diagram .....	<b>23</b>
6.3 Recommended Operating Conditions .....	<b>7</b>	8.3 Feature Description .....	<b>24</b>
6.4 Thermal Information .....	<b>7</b>	8.4 Device Functional Modes .....	<b>24</b>
6.5 Power Ratings .....	<b>7</b>	<b>9 Application and Implementation</b> .....	<b>25</b>
6.6 Insulation Specifications .....	<b>8</b>	9.1 Application Information .....	<b>25</b>
6.7 Safety-Related Certifications .....	<b>9</b>	9.2 Typical Application .....	<b>25</b>
6.8 Safety Limiting Values .....	<b>9</b>	<b>10 Power Supply Recommendations</b> .....	<b>27</b>
6.9 Electrical Characteristics—5-V $V_{CC1}$ and $V_{CC2}$ Supplies .....	<b>10</b>	<b>11 Layout</b> .....	<b>27</b>
6.10 Electrical Characteristics—5-V $V_{CC1}$ and 3.3-V $V_{CC2}$ Supply .....	<b>11</b>	11.1 Layout Guidelines .....	<b>27</b>
6.11 Electrical Characteristics—3.3-V $V_{CC1}$ and 5-V $V_{CC2}$ Supply .....	<b>12</b>	11.2 Layout Example .....	<b>27</b>
6.12 Electrical Characteristics—3.3-V $V_{CC1}$ and $V_{CC2}$ Supplies .....	<b>13</b>	<b>12 Device and Documentation Support</b> .....	<b>28</b>
6.13 Electrical Characteristics—2.8-V $V_{CC1}$ and $V_{CC2}$ Supplies .....	<b>13</b>	12.1 Device Support .....	<b>28</b>
6.14 Switching Characteristics—5-V $V_{CC1}$ and $V_{CC2}$ Supplies .....	<b>14</b>	12.2 Documentation Support .....	<b>28</b>
6.15 Switching Characteristics—5-V $V_{CC1}$ and 3.3-V $V_{CC2}$ Supply .....	<b>15</b>	12.3 Related Links .....	<b>28</b>
6.16 Switching Characteristics—3.3-V $V_{CC1}$ and 5-V $V_{CC2}$ Supplies .....	<b>16</b>	12.4 Receiving Notification of Documentation Updates .....	<b>28</b>
6.17 Switching Characteristics—3.3-V $V_{CC1}$ and $V_{CC2}$ Supplies .....	<b>17</b>	12.5 Community Resources .....	<b>28</b>
		12.6 Trademarks .....	<b>29</b>
		12.7 Electrostatic Discharge Caution .....	<b>29</b>
		12.8 Glossary .....	<b>29</b>
		<b>13 Mechanical, Packaging, and Orderable Information</b> .....	<b>29</b>

## 4 Revision History

NOTE: Page numbers for previous revisions may differ from page numbers in the current version.

Changes from Revision O (April 2017) to Revision P	Page
• Changed (VDE V 0884-10):2006-12 to DIN VDE V 0884-11:2017-01 throughout the document .....	<b>1</b>
• Changed CSA Approved for Component Acceptance Notice 5A and IEC 60950-1 to CSA Approved for IEC 60950-1 and IEC 62368-1 throughout the document .....	<b>1</b>
• Added the basic insulation working voltage for CSA in the <i>Safety-Related Certifications</i> table .....	<b>9</b>
• Changed the VDE certification number from 40016131 to 40047657 in the <i>Safety-Related Certifications</i> table .....	<b>9</b>
• Changed the maximum propagation delay and pulse-width distortion in each <i>Switching Characteristics</i> table .....	<b>14</b>
• Added $\pm 10\%$ for the $V_{CC1}$ and $V_{CC2}$ voltages in the condition statement of the <i>Switching Characteristics—5-V <math>V_{CC1}</math> and <math>V_{CC2}</math> Supplies</i> table .....	<b>14</b>
• Changed ISO722x to ISO7220 for all part numbers for the Channel-to-channel output skew parameter in each <i>Switching Characteristic</i> table .....	<b>14</b>

Changes from Revision N (September 2015) to Revision O	Page
• Changed the <i>Dissipation Characteristics</i> table to <i>Power Ratings</i> . Combined the DIN VDE V 0884-10 (VDE V 0884-10):2006-12 <i>Insulation Characteristics</i> table IEC Package Characteristics, and IEC 60664-1 Ratings Table in the <i>Insulation Specifications</i> table. Changed the <i>Regulatory Information</i> table to <i>Safety-Related Certifications</i> .....	<b>7</b>
• Deleted the maximum surge voltage, 4000 $V_{PK}$ for VDE in the <i>Safety-Related Certifications</i> table .....	<b>9</b>

• Changed the CSA information in the <i>Safety-Related Certifications</i> table .....	9
• Added the <i>Receiving Notification of Documentation Updates</i> section .....	28
• Changed the <i>Electrostatic Discharge Caution</i> section .....	28

---

<b>Changes from Revision M (October 2014) to Revision N</b>	<b>Page</b>
---	-------------

---

• Changed the VDE Cerification from: DIN EN 60747-5-5 (VDE 0884-5) to: DIN V VDE V 0884-10 (VDE V 0884-10):2006-12 throughout the document .....	1
• Updated the <i>Simplified Schematic</i> to a higher quality version. ....	1
• Changed the max value of the IN and OUT voltage from 6 to $V_{CC} + 0.5$ in the <i>Absolute Maximum Ratings</i> table. ....	6
• Changed L(I01) MIN value from 4.8 to 4 in the <i>IEC Package Characteristics</i> table. ....	8
• Added the JEDEC package dimensions note in the <i>IEC Package Characteristics</i> table. ....	8
• Changed L(I01) MIN value from 4.8 to 4 in the <i>IEC Package Characteristics</i> table. ....	8
• Added the DTI parameter to the <i>IEC Package Characteristics</i> table. ....	8
• Changed the DTI test condition From: IEC 60112 / VDE 0303 Part 1 To: DIN EN 60112 (VDE 0303-11); IEC 60112 .....	8
• Added = 150°C to insulation resistance test condition in the <i>DIN V VDE V 0884-10 (VDE V 0884-10):2006-12 Insulation Characteristics</i> table. ....	8
• Added table row with input side $V_{CC} = X$ to the <i>ISO7220x or ISO7221x Function</i> table. ....	24

---

<b>Changes from Revision L (January 2012) to Revision M</b>	<b>Page</b>
---	-------------

---

• Changed the title of this data sheet to <i>ISO722x Dual Channel Digital Isolators</i> .....	1
• Added <i>Pin Configuration and Functions</i> section, <i>Handling Rating</i> table, <i>Dissipation Ratings</i> table, <i>Feature Description</i> section, <i>Device Functional Modes, Application and Implementation</i> section, <i>Power Supply Recommendations</i> section, <i>Layout</i> section, <i>Device and Documentation Support</i> section, and <i>Mechanical, Packaging, and Orderable Information</i> section, changed <i>Thermal Information</i> table .....	1
• Updated the <i>Features</i> section .....	1
• Added per VDE to 4000 $V_{PK}$ in second sentence of <i>Description</i> .....	1
• Updated the <i>Regulatory Information</i> Table. ....	6
• Added the min and max values to the Storage temperature parameter in the <i>Absolute Maximum Ratings</i> table. ....	6
• Changed in ROC table Max col, $V_{IH}$ row from VCC to 5.5 .....	7
• Changed the L(I01) parameter name to external clearance (CLR) and L(I02) to external creepage (CPG). Also changed the input-to-output test voltage ( $V_{PR}$ ) parameter name to apparent charge ( $q_{pd}$ ) .....	8
• Changed the <i>Device Options</i> table, Input Threshold column from ≠ symbol to ~ symbol 6 places .....	24
• Changed <i>Isolation Glossary</i> .....	28

---

<b>Changes from Revision K (January 2010) to Revision L</b>	<b>Page</b>
---	-------------

---

• Changed Feature From: Operates with 3.3-V or 5-V Supplies To: Operates with 2.8-V (C-Grade), 3.3-V or 5-V Supplies .	1
• Changed Feature From: 4000- $V_{peak}$ Isolation, 560 $V_{peak} V_{IORM}$ To: 4000- $V_{PK} V_{IOTM}$ , 560 $V_{PK} V_{IORM}$ per IEC 60747-5-2 (VDE 0884, Rev2) .....	1
• Added device options to $V_{CC}$ in the RECOMMENDED OPERATING CONDITIONS table .....	7
• Changed Note: (1) in the RECOMMENDED OPERATING CONDITIONS table .....	7
• Changed the CTI MIN value From: ≥175 V To: ≥400 V .....	8
• Updated the <i>Regulatory Information</i> table. ....	9
• Changed $I_{CC1}$ and $I_{CC2}$ test conditions in the 5-V table. ....	10
• Changed Table Note: (1) .....	10
• Changed $I_{CC1}$ and $I_{CC2}$ test conditions in the $V_{CC1}$ at 5 V, $V_{CC2}$ at 3.3 V table. ....	11
• Changed Table Note: (1) .....	11

---

• Changed $I_{CC1}$ and $I_{CC2}$ test conditions in the $V_{CC1}$ at 3.3 V, $V_{CC2}$ at 5 V table.....	12
• Changed Table Note (1) .....	12
• Changed $I_{CC1}$ and $I_{CC2}$ test conditions in the $V_{CC1}$ and $V_{CC2}$ at 3.3 V table .....	13
• Changed Table Note (1) .....	13
• Added ELECTRICAL and Switching CHARACTERISTICS table for $V_{CC1}$ and $V_{CC2}$ at 2.8 V (ISO722xC-Only) .....	13
• Changed $V_{CC}$ Undervoltage Threshold vs Free-Air Temperature .....	19
• Changed Failsafe Delay Time Test Circuit and Voltage Waveforms .....	21

**Changes from Revision J (May 2009) to Revision K Page**

• Changed the RECOMMENDED OPERATING CONDITIONS so that Note (2) is associated with all device options in the Input pulse width and Signaling rate .....	7
• Changed Note (2) From: Typical signaling rate under ideal conditions at 25°C. To: Typical signaling rate and Input pulse width are measured at ideal conditions at 25°C. ....	7
• Changed column 2 of the AVAILABLE OPTIONS table From: Signaling Rate To: Max Signaling Rate .....	24

**Changes from Revision I (December 2008) to Revision J Page**

• Changed ISO7221C Marked As column From: TI7221C To: I7221C in the AVAILABLE OPTIONS table .....	24
---	----

**Changes from Revision H (May 2008) to Revision I Page**

• Added "IEC 61010-1, IEC 60950-1 and CSA Approved" to the UL 1577 FEATURES bullet .....	1
--	---

**Changes from Revision G (March 2008) to Revision H Page**

• Added Note: (1) to the RECOMMENDED OPERATING CONDITIONS table .....	7
• Added Note: (1) to the ELECTRICAL CHARACTERISTICS: $V_{CC1}$ and $V_{CC2}$ at 5-V table.....	10
• Added Note: (1) to the ELECTRICAL CHARACTERISTICS: $V_{CC1}$ at 5 V, $V_{CC2}$ at 3.3 V table .....	11
• Added Note (1): to the ELECTRICAL CHARACTERISTICS: $V_{CC1}$ at 3.3 V, $V_{CC2}$ at 5 V table .....	12
• Added Note (1): to the ELECTRICAL CHARACTERISTICS: $V_{CC1}$ and $V_{CC2}$ at 3.3 V.....	13

**Changes from Revision F (August 2007) to Revision G Page**

• Added Part Numbers ISO7220B and ISO7221B to the data sheet.....	1
• Added 5-Mbps Signaling rate to the FEATURES list .....	1
• Added Part Numbers ISO7220B and ISO7221B to the ELECTRICAL CHARACTERISTICS: $V_{CC1}$ and $V_{CC2}$ at 5-V table .	10
• Added Part Numbers ISO7220B and ISO7221B to the ELECTRICAL CHARACTERISTICS: $V_{CC1}$ at 5 V, $V_{CC2}$ at 3.3 V table.....	11
• Added Part Numbers ISO7220B and ISO7221B to the ELECTRICAL CHARACTERISTICS: $V_{CC1}$ at 3.3 V, $V_{CC2}$ at 5 V table.....	12
• Added Part Numbers ISO7220B and ISO7221B to the ELECTRICAL CHARACTERISTICS: $V_{CC1}$ and $V_{CC2}$ at 3.3 V.....	13
• Added PROPAGATION DELAY vs FREE-AIR TEMPERATURE, ISO722xB, <i>Propagation Delay vs Free-Air Temperature, ISO722xB</i> .....	19
• Added Part Numbers ISO7220B and ISO7221B to the AVAILABLE OPTIONS table.....	24

<b>Changes from Revision E (July 2007) to Revision F</b>	<b>Page</b>
• Added $t_{sk(pp)}$ footnote to the SWITCHING CHARACTERISTICS: $V_{CC1}$ and $V_{CC2}$ at 5-V OPERATION table .....	14
• Added $t_{sk(o)}$ footnote to the SWITCHING CHARACTERISTICS: $V_{CC1}$ and $V_{CC2}$ at 5-V OPERATION table.....	14
• Added $t_{sk(pp)}$ footnote to the SWITCHING CHARACTERISTICS: $V_{CC1}$ at 5 V, $V_{CC2}$ at 3.3 V OPERATION table.....	15
• Added $t_{sk(o)}$ footnote to the SWITCHING CHARACTERISTICS: $V_{CC1}$ at 5 V, $V_{CC2}$ at 3.3 V OPERATION table .....	15
• Added $t_{sk(pp)}$ footnote to the SWITCHING CHARACTERISTICS: $V_{CC1}$ at 3.3 V, $V_{CC2}$ at 5 V OPERATION table.....	16
• Added $t_{sk(o)}$ footnote to the SWITCHING CHARACTERISTICS: $V_{CC1}$ at 3.3 V, $V_{CC2}$ at 5 V OPERATION table .....	16
• Added $t_{sk(pp)}$ footnote to the SWITCHING CHARACTERISTICS table.....	17
• Changed 3.3- $V_{RMS}$ <i>Supply Current vs Signaling Rate</i> - Re-scaled the Y-axis .....	19
• Changed 5- $V_{RMS}$ <i>Supply Current vs Signaling Rate</i> - New Curves.....	19
<hr/>	
<b>Changes from Revision D (June 2007) to Revision E</b>	<b>Page</b>
• Changed 3.3- $V_{RMS}$ <i>Supply Current vs Signaling Rate</i> - New Curves.....	19
• Changed 5- $V_{RMS}$ <i>Supply Current vs Signaling Rate</i> - Re-scaled the Y-axis .....	19
<hr/>	
<b>Changes from Revision C (May 2007) to Revision D</b>	<b>Page</b>
• Changed <i>Typical ISO7220x Circuit Hook-Up</i> - Pin 2 (INA) label From: OUTPUT to INPUT .....	26
<hr/>	
<b>Changes from Revision B (May 2007) to Revision C</b>	<b>Page</b>
• Added the Signaling rate values to the RECOMMENDED OPERATING CONDITIONS table.....	7
• Changed the IEC 60664-1 RATINGS TABLE - Specification I-III test conditions From: Rated mains voltage $\leq 150$ VRMS To: Rated mains voltage $\leq 300$ VRMS. Added a row for the I-II specifications.....	8
• Added <i>ISO722xM Jitter vs Signaling Rate</i> cross reference to the Peak-to-peak eye-pattern jitter of the SWITCHING CHARACTERISTICS table .....	14
• Added <i>Time-Dependent Dielectric Breakdown Test Results</i> .....	26
<hr/>	
<b>Changes from Revision A (August 2006) to Revision B</b>	<b>Page</b>
• Added the TYPICAL CHARACTERISTIC CURVES to the data sheet. ....	19
• Added the PARAMETER MEASUREMENT INFORMATION to the data sheet .....	21
• Added the APPLICATION INFORMATION section to the data sheet.....	25
• Added the ISOLATION GLOSSARY section to the data sheet .....	28
<hr/>	
<b>Changes from Original (July 2006) to Revision A</b>	<b>Page</b>
• Deleted "and CSA Apporved" from the UL 1577 FEATURES bullet.....	1
• Added option A to the AVAILABLE OPTIONS table .....	24
<hr/>	

## 5 Pin Configuration and Functions

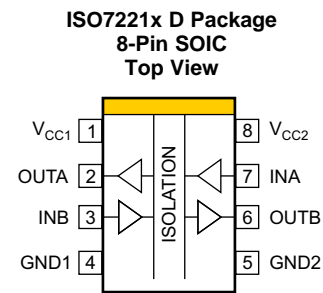
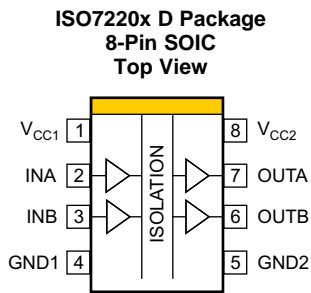

### Pin Functions

PIN		I/O	DESCRIPTION	
NAME	ISO7220x			ISO7221x
INA	2	7	I	Input, channel A
INB	3	3	I	Input, channel B
GND1	4	4	—	Ground connection for $V_{CC1}$
GND2	5	5	—	Ground connection for $V_{CC2}$
OUTA	7	2	O	Output, channel A
OUTB	6	6	O	Output, channel B
$V_{CC1}$	1	1	—	Power supply, $V_{CC1}$
$V_{CC2}$	8	8	—	Power supply, $V_{CC2}$

## 6 Specifications

### 6.1 Absolute Maximum Ratings

over operating free-air temperature range (unless otherwise noted)<sup>(1)</sup>

	MIN	MAX	UNIT
$V_{CC}$ Supply voltage <sup>(2)</sup> , $V_{CC1}$ , $V_{CC2}$	-0.5	6	V
$V_I$ Voltage at IN, OUT	-0.5	$V_{CC} + 0.5$ <sup>(3)</sup>	V
$I_O$ Output current	-15	15	mA
$T_J$ Maximum junction temperature		170	°C
$T_{stg}$ Storage temperature	-65	150	°C

- Stresses beyond those listed under *Absolute Maximum Ratings* can cause permanent damage to the device. These ratings are stress ratings only and functional operation of the device at these or any other conditions beyond those indicated under *Recommended Operating Conditions* is not implied. Exposure to absolute-maximum-rated conditions for extended periods can affect device reliability.
- All voltage values except differential I/O bus voltages are with respect to network ground pin and are peak voltage values.
- Maximum voltage must not exceed 6 V.

### 6.2 ESD Ratings

	VALUE	UNIT	
$V_{(ESD)}$ Electrostatic discharge	Human body model (HBM), per ANSI/ESDA/JEDEC JS-001, all pins <sup>(1)</sup>	±4000	V
	Charged device model (CDM), per JEDEC specification JESD22-C101, all pins <sup>(2)</sup>	±1000	V
	Machine Model, ANSI/ESDS5.2-1996	±200	V

- JEDEC document JEP155 states that 500-V HBM allows safe manufacturing with a standard ESD control process.
- JEDEC document JEP157 states that 250-V CDM allows safe manufacturing with a standard ESD control process.

### 6.3 Recommended Operating Conditions

		MIN	NOM	MAX	UNIT		
V <sub>CC</sub>	Supply voltage <sup>(1)</sup> , V <sub>CC1</sub> , V <sub>CC2</sub>	ISO722xA, ISO722xB, ISO722xM		3	5.5	V	
		ISO722xC		2.8	5.5		
I <sub>OH</sub>	High-level output current	-4				mA	
I <sub>OL</sub>	Low-level output current				4	mA	
t <sub>ui</sub>	Input pulse width <sup>(2)</sup>	ISO722xA		1	0.67	μs	
		ISO722xB		200	100	ns	
		ISO722xC		40	33		
		ISO722xM		6.67	5		
1/t <sub>ui</sub>	Signaling rate <sup>(2)</sup>	ISO722xA		0	1500	1000	kbps
		ISO722xB		0	10	5	Mbps
		ISO722xC		0	30	25	
		ISO722xM		0	200	150	
V <sub>IH</sub>	High-level input voltage	ISO722xA, ISO722xB, ISO722xC		2	5.5	V	
V <sub>IL</sub>	Low-level input voltage	ISO722xA, ISO722xB, ISO722xC		0	0.8	V	
V <sub>IH</sub>	High-level input voltage	ISO722xM		0.7 V <sub>CC</sub>	V <sub>CC</sub>	V	
V <sub>IL</sub>	Low-level input voltage	ISO722xM		0	0.3 V <sub>CC</sub>	V	
T <sub>J</sub>	Junction temperature	-40			150	°C	
H	External magnetic field-strength immunity per IEC 61000-4-8 and IEC 61000-4-9 certification				1000	A/m	

- (1) For the 5-V operation, V<sub>CC1</sub> or V<sub>CC2</sub> is specified from 4.5 V to 5.5 V.  
For the 3.3-V operation, V<sub>CC1</sub> or V<sub>CC2</sub> is specified from 3 V to 3.6 V.  
For the 2.8-V operation, V<sub>CC1</sub> or V<sub>CC2</sub> is specified at 2.8 V.
- (2) Typical signaling rate and input pulse width are measured at ideal conditions at 25°C.

### 6.4 Thermal Information

THERMAL METRIC <sup>(1)</sup>		ISO7220x ISO7221x	UNIT	
		D (SOIC)		
		8 PINS		
R <sub>θJA</sub>	Junction-to-ambient thermal resistance	Low-K Thermal Resistance <sup>(2)</sup>	212	°C/W
		High-K Thermal Resistance	122	
R <sub>θJC(top)</sub>	Junction-to-case (top) thermal resistance		69.1	°C/W
R <sub>θJB</sub>	Junction-to-board thermal resistance		47.7	°C/W
ψ <sub>JT</sub>	Junction-to-top characterization parameter		15.2	°C/W
ψ <sub>JB</sub>	Junction-to-board characterization parameter		47.2	°C/W
R <sub>θJC(bot)</sub>	Junction-to-case (bottom) thermal resistance		—	°C/W

- (1) For more information about traditional and new thermal metrics, see the [Semiconductor and IC Package Thermal Metrics application report](#).
- (2) Tested in accordance with the Low-K or High-K thermal metric definitions of EIA/JESD51-3 for leaded surface mount packages.

### 6.5 Power Ratings

V<sub>CC1</sub> = V<sub>CC2</sub> = 5.5 V, T<sub>J</sub> = 150°C, C<sub>L</sub> = 15 pF, Input a 150 Mbps 50% duty cycle square wave

PARAMETER	TEST CONDITIONS	MIN	TYP	MAX	UNIT
P <sub>D</sub>	Device power dissipation, ISO722xM			390	mW

## 6.6 Insulation Specifications

PARAMETER		TEST CONDITIONS	VALUE	UNIT
<b>GENERAL</b>				
CLR	External clearance <sup>(1)</sup>	Shortest terminal-to-terminal distance through air	4	mm
CPG	External creepage <sup>(1)</sup>	Shortest terminal-to-terminal distance across the package surface	4	mm
DTI	Distance through the insulation	Minimum internal gap (internal clearance)	0.008	mm
CTI	Comparative tracking index	DIN EN 60112 (VDE 0303-11); IEC 60112	400	V
	Material group		II	
	Overvoltage category	Rated mains voltage $\leq 150 V_{RMS}$	I-IV	
		Rated mains voltage $\leq 300 V_{RMS}$	I-III	
		Rated mains voltage $\leq 400 V_{RMS}$	I-II	
<b>DIN VDE V 0884-11:2017-01<sup>(2)</sup></b>				
$V_{IORM}$	Maximum repetitive peak isolation voltage	AC voltage (bipolar)	560	$V_{PK}$
$V_{IOTM}$	Maximum transient isolation voltage	$V_{TEST} = V_{IOTM}$ $t = 60$ s (qualification), $t = 1$ s (100% production)	4000	$V_{PK}$
$q_{pd}$	Apparent charge <sup>(3)</sup>	Method a: After I/O safety test subgroup 2/3, $V_{ini} = V_{IOTM}$ , $t_{ini} = 60$ s; $V_{pd(m)} = 1.2 \times V_{IORM}$ , $t_m = 10$ s	$\leq 5$	pC
		Method a: After environmental tests subgroup 1, $V_{ini} = V_{IOTM}$ , $t_{ini} = 60$ s; $V_{pd(m)} = 1.3 \times V_{IORM}$ , $t_m = 10$ s	$\leq 5$	
		Method b1: At routine test (100% production) and preconditioning (type test) $V_{ini} = V_{IOTM}$ , $t_{ini} = 1$ s; $V_{pd(m)} = 1.5 \times V_{IORM}$ , $t_m = 1$ s	$\leq 5$	
$C_{IO}$	Barrier capacitance, input to output <sup>(4)</sup>	$V_{IO} = 0.4 \sin(4E6\pi t)$	1	pF
$R_{IO}$	Isolation resistance, input to output <sup>(4)</sup>	$V_{IO} = 500$ V, $T_A = 25^\circ\text{C}$	$>10^{12}$	$\Omega$
		$V_{IO} = 500$ V, $100^\circ\text{C} \leq T_A \leq 125^\circ\text{C}$	$>10^{11}$	
		$V_{IO} = 500$ V at $T_S = 150^\circ\text{C}$	$>10^9$	
	Pollution degree		2	
	Climatic category		40/125/21	
<b>UL 1577</b>				
$V_{ISO}$	Withstand isolation voltage	$V_{TEST} = V_{ISO} = 2500 V_{RMS}$ , $t = 60$ s (qualification); $V_{TEST} = 1.2 \times V_{ISO} = 3000 V_{RMS}$ , $t = 1$ s (100% production)	2500	$V_{RMS}$

- (1) Creepage and clearance requirements should be applied according to the specific equipment isolation standards of an application. Care should be taken to maintain the creepage and clearance distance of a board design to ensure that the mounting pads of the isolator on the printed-circuit board do not reduce this distance. Creepage and clearance on a printed-circuit board become equal in certain cases. Techniques such as inserting grooves and/or ribs on a printed circuit board are used to help increase these specifications.
- (2) This coupler is suitable for *basic electrical insulation* only within the maximum operating ratings. Compliance with the safety ratings shall be ensured by means of suitable protective circuits.
- (3) Apparent charge is electrical discharge caused by a partial discharge (pd).
- (4) All pins on each side of the barrier tied together creating a two-terminal device

## 6.7 Safety-Related Certifications

VDE	CSA	UL
Certified according to DIN VDE V 0884-11:2017-01 and DIN EN 61010-1 (VDE 0411-1):2011-07	Certified according to IEC 60950-1 and IEC 62368-1	Recognized under UL 1577 Component Recognition Program
Basic Insulation Maximum Transient Overvoltage, 4000 V <sub>PK</sub> ; Maximum Repetitive Peak Isolation Voltage, 560 V <sub>PK</sub>	2000 V <sub>RMS</sub> Isolation rating 400 V <sub>RMS</sub> Basic insulation and 148 V <sub>RMS</sub> Reinforced insulation working voltage per CSA 60950-1-07+A1+A2 and IEC 60950-1 2nd Ed. +A1+A2. 300 V <sub>RMS</sub> Basic insulation working voltage per CSA 62369-1-14 and IEC 62368-1:2014 Ed. 2.	Single protection, 2500 V <sub>RMS</sub>
Certificate number: 40047657	Master contract number: 220991	File number: E181974

## 6.8 Safety Limiting Values

Safety limiting<sup>(1)</sup> intends to minimize potential damage to the isolation barrier upon failure of input or output circuitry. A failure of the I/O can allow low resistance to ground or the supply and, without current limiting, dissipate sufficient power to overheat the die and damage the isolation barrier, potentially leading to secondary system failures.

PARAMETER	TEST CONDITIONS	MIN	TYP	MAX	UNIT
I <sub>S</sub> Safety input, output, or supply current	R <sub>θJA</sub> = 212°C/W, V <sub>I</sub> = 5.5 V, T <sub>J</sub> = 170°C, T <sub>A</sub> = 25°C, see <a href="#">Figure 1</a>			124	mA
	R <sub>θJA</sub> = 212°C/W, V <sub>I</sub> = 3.6 V, T <sub>J</sub> = 170°C, T <sub>A</sub> = 25°C, see <a href="#">Figure 1</a>			190	
T <sub>S</sub> Safety temperature				150	°C

- (1) The safety-limiting constraint is the maximum junction temperature specified in the data sheet. The power dissipation and junction-to-air thermal impedance of the device installed in the application hardware determines the junction temperature. The assumed junction-to-air thermal resistance in the [Thermal Information](#) table is that of a device installed on a high-K test board for leaded surface-mount packages. The power is the recommended maximum input voltage times the current. The junction temperature is then the ambient temperature plus the power times the junction-to-air thermal resistance.

## 6.9 Electrical Characteristics—5-V $V_{CC1}$ and $V_{CC2}$ Supplies

$V_{CC1}$  and  $V_{CC2}$  at 5 V  $\pm$  10% (over recommended operating conditions unless otherwise noted.)

PARAMETER		TEST CONDITIONS	MIN	TYP	MAX	UNIT
$I_{CC1}$	$V_{CC1}$ supply current	ISO7220x quiescent, $V_I = V_{CC}$ or 0 V, no load		1	2	mA
		ISO7221 quiescent, $V_I = V_{CC}$ or 0 V, no load		8.5	17	
		ISO7220A and ISO7220B 1 Mbps, 0.5-MHz input clock signal, no load		2	3	mA
		ISO7221A, ISO7221B 1 Mbps, 0.5-MHz input clock signal, no load		10	18	
		ISO7220C, ISO7220M 25 Mbps, 12.5-MHz input clock signal, no load		4	9	mA
		ISO7221C and ISO7221M 25 Mbps, 12.5-MHz input clock signal, no load		12	22	
$I_{CC2}$	$V_{CC2}$ supply current	ISO7220x quiescent, $V_I = V_{CC}$ or 0 V, no load		16	31	mA
		ISO7221x quiescent, $V_I = V_{CC}$ or 0 V, no load		8.5	17	
		ISO7220A and ISO7220B 1 Mbps, 0.5-MHz input clock signal, no load		17	32	mA
		ISO7221A, ISO7221B 1 Mbps, 0.5-MHz input clock signal, no load		10	18	
		ISO7220C, ISO7220M 25 Mbps, 12.5-MHz input clock signal, no load		20	34	mA
		ISO7221C and ISO7221M 25 Mbps, 12.5-MHz input clock signal, no load		12	22	
$V_{OH}$	High-level output voltage	$I_{OH} = -4$ mA, See <a href="#">Figure 14</a>	$V_{CC} - 0.8$	4.6		V
		$I_{OH} = -20$ $\mu$ A, See <a href="#">Figure 14</a>	$V_{CC} - 0.1$	5		
$V_{OL}$	Low-level output voltage	$I_{OL} = 4$ mA, See <a href="#">Figure 14</a>		0.2	0.4	V
		$I_{OL} = 20$ $\mu$ A, See <a href="#">Figure 14</a>		0	0.1	
$V_{I(HYS)}$	Input voltage hysteresis			150		mV
$I_{IH}$	High-level input current	IN from 0 V to $V_{CC}$			10	$\mu$ A
$I_{IL}$	Low-level input current	IN from 0 V to $V_{CC}$	-10			$\mu$ A
$C_I$	Input capacitance to ground	IN at $V_{CC}$ , $V_I = 0.4 \sin(4E6\pi t)$		1		pF
CMTI	Common-mode transient immunity	$V_I = V_{CC}$ or 0 V, See <a href="#">Figure 16</a>	25	50		kV/ $\mu$ s

## 6.10 Electrical Characteristics—5-V $V_{CC1}$ and 3.3-V $V_{CC2}$ Supply

 $V_{CC1}$  at 5 V  $\pm$  10%,  $V_{CC2}$  at 3.3 V  $\pm$  10% (over recommended operating conditions unless otherwise noted.)

PARAMETER	TEST CONDITIONS	MIN	TYP	MAX	UNIT
$I_{CC1}$	$V_{CC1}$ supply current	ISO7220x quiescent, $V_I = V_{CC}$ or 0 V, no load	1	2	mA
			ISO7221x quiescent, $V_I = V_{CC}$ or 0 V, no load	8.5	
		ISO7220A and ISO7220B 1 Mbps, 0.5-MHz input clock signal, no load	2	3	mA
			ISO7221A and ISO7221B 1 Mbps, 0.5-MHz input clock signal, no load	10	
		ISO7220C and ISO7220M 25 Mbps, 12.5-MHz input clock signal, no load	4	9	mA
			ISO7221C and ISO7221M 25 Mbps, 12.5-MHz input clock signal, no load	12	
$I_{CC2}$	$V_{CC2}$ supply current	ISO7220x quiescent, $V_I = V_{CC}$ or 0 V, no load	8	18	mA
			ISO7221x quiescent, $V_I = V_{CC}$ or 0 V, no load	4.3	
		ISO7220A and ISO7220B 1 Mbps, 0.5-MHz input clock signal, no load	9	19	mA
			ISO7221A and ISO7221B 1 Mbps, 0.5-MHz input clock signal, no load	5	
		ISO7220C and ISO7220M 25 Mbps, 12.5-MHz input clock signal, no load	10	20	mA
			ISO7221C and ISO7221M 25 Mbps, 12.5-MHz input clock signal, no load	6	
$V_{OH}$	High-level output voltage	ISO7220x, ISO7221x (3.3-V side), $I_{OH} = -4$ mA, See <a href="#">Figure 14</a>	$V_{CC} - 0.4$		V
		ISO7221x (5-V side), $I_{OH} = -4$ mA, See <a href="#">Figure 14</a>	$V_{CC} - 0.8$		
		All devices, $I_{OH} = -20$ $\mu$ A, See <a href="#">Figure 14</a>	$V_{CC} - 0.1$		
$V_{OL}$	Low-level output voltage	$I_{OL} = 4$ mA, See <a href="#">Figure 14</a>	0.4		V
		$I_{OL} = 20$ $\mu$ A, See <a href="#">Figure 14</a>	0.1		
$V_{I(HYS)}$	Input voltage hysteresis		150		mV
$I_{IH}$	High-level input current	IN from 0 V to $V_{CC}$		10	$\mu$ A
$I_{IL}$	Low-level input current	IN from 0 V to $V_{CC}$	-10		$\mu$ A
$C_I$	Input capacitance to ground	IN at $V_{CC}$ , $V_I = 0.4 \sin(4E6\pi t)$	1		pF
CMTI	Common-mode transient immunity	$V_I = V_{CC}$ or 0 V, See <a href="#">Figure 16</a>	15	40	kV/ $\mu$ s

## 6.11 Electrical Characteristics—3.3-V $V_{CC1}$ and 5-V $V_{CC2}$ Supply

$V_{CC1}$  at 3.3 V  $\pm$  10%,  $V_{CC2}$  at 5 V  $\pm$  10% (over recommended operating conditions unless otherwise noted.)

PARAMETER		TEST CONDITIONS	MIN	TYP	MAX	UNIT
$I_{CC1}$	$V_{CC1}$ supply current	ISO7220x quiescent, $V_I = V_{CC}$ or 0 V, no load		0.6	1	mA
		ISO7221x quiescent, $V_I = V_{CC}$ or 0 V, no load		4.3	9.5	
		ISO7220A and ISO7220B 1 Mbps, 0.5-MHz input clock signal, no load		1	2	mA
		ISO7221A and ISO7221B 1 Mbps, 0.5-MHz input clock signal, no load		5	11	
		ISO7220C and ISO7220M 25 Mbps, 12.5-MHz input clock signal, no load		2	4	mA
		ISO7221C and ISO7221M 25 Mbps, 12.5-MHz input clock signal, no load		6	12	
$I_{CC2}$	$V_{CC2}$ supply current	ISO7220x quiescent, $V_I = V_{CC}$ or 0 V, no load		16	31	mA
		ISO7221x quiescent, $V_I = V_{CC}$ or 0 V, no load		8.5	17	
		ISO7220A and ISO7220B 1 Mbps, 0.5-MHz input clock signal, no load		18	32	mA
		ISO7221A and ISO7221B 1 Mbps, 0.5-MHz input clock signal, no load		10	18	
		ISO7220C and ISO7220M 25 Mbps, 12.5-MHz input clock signal, no load		20	34	mA
		ISO7221C and ISO7221M 25 Mbps, 12.5-MHz input clock signal, no load		12	22	
$V_{OH}$	High-level output voltage	ISO7220x and ISO7221x (5-V side), $I_{OH} = -4$ mA, See <a href="#">Figure 14</a>	$V_{CC} - 0.8$		V	
		ISO7221x (3.3-V side), $I_{OH} = -4$ mA, See <a href="#">Figure 14</a>	$V_{CC} - 0.4$			
		All devices, $I_{OH} = -20$ $\mu$ A, See <a href="#">Figure 14</a>	$V_{CC} - 0.1$			
$V_{OL}$	Low-level output voltage	$I_{OL} = 4$ mA, See <a href="#">Figure 14</a>			0.4	
		$I_{OL} = 20$ $\mu$ A, See <a href="#">Figure 14</a>		0	0.1	
$V_{I(HYS)}$	Input threshold voltage hysteresis			150	mV	
$I_{IH}$	High-level input current	IN from 0 V or $V_{CC}$			10	$\mu$ A
$I_{IL}$	Low-level input current	IN from 0 V or $V_{CC}$	-10			$\mu$ A
$C_I$	Input capacitance to ground	IN at $V_{CC}$ , $V_I = 0.4 \sin(4E6\pi t)$		1		pF
CMTI	Common-mode transient immunity	$V_I = V_{CC}$ or 0 V, See <a href="#">Figure 16</a>	15	40		kV/ $\mu$ s

## 6.12 Electrical Characteristics—3.3-V $V_{CC1}$ and $V_{CC2}$ Supplies

 $V_{CC1}$  and  $V_{CC2}$  at 3.3 V  $\pm$  10% (over recommended operating conditions unless otherwise noted.)<sup>(1)</sup>

PARAMETER		TEST CONDITIONS	MIN	TYP	MAX	UNIT
$I_{CC1}$	$V_{CC2}$ supply current	ISO7220x quiescent, $V_I = V_{CC}$ or 0 V, no load		0.6	1	mA
		ISO7221x quiescent, $V_I = V_{CC}$ or 0 V, no load		4.3	9.5	
		ISO7220A and ISO7220B 1 Mbps, 0.5-MHz input clock signal, no load		1	2	mA
		ISO7221A and ISO7221B 1 Mbps, 0.5-MHz input clock signal, no load		5	11	
		ISO7220C and ISO7220M 25 Mbps, 12.5-MHz input clock signal, no load		2	4	mA
		ISO7221C and ISO7221M 25 Mbps, 12.5-MHz input clock signal, no load		6	12	
$I_{CC2}$	$V_{CC2}$ supply current	ISO7220x quiescent, $V_I = V_{CC}$ or 0 V, no load		8	18	mA
		ISO7221x quiescent, $V_I = V_{CC}$ or 0 V, no load		4.3	9.5	
		ISO7220A and ISO7220B 1 Mbps, 0.5-MHz input clock signal, no load		9	19	mA
		ISO7221A and ISO7221B 1 Mbps, 0.5-MHz input clock signal, no load		5	11	
		ISO7220C and ISO7220M 25 Mbps, 12.5-MHz input clock signal, no load		10	20	mA
		ISO7221C and ISO7221M 25 Mbps, 12.5-MHz input clock signal, no load		6	12	
$V_{OH}$	High-level output voltage	$I_{OH} = -4$ mA, See <a href="#">Figure 14</a>	$V_{CC} - 0.4$	3	V	
		$I_{OH} = -20$ $\mu$ A, See <a href="#">Figure 14</a>	$V_{CC} - 0.1$	3.3		
$V_{OL}$	Low-level output voltage	$I_{OL} = 4$ mA, See <a href="#">Figure 14</a>		0.2		0.4
		$I_{OL} = 20$ $\mu$ A, See <a href="#">Figure 14</a>		0		0.1
$V_{I(HYS)}$	Input voltage hysteresis			150	mV	
$I_{IH}$	High-level input current	IN from 0 V or $V_{CC}$			10	$\mu$ A
$I_{IL}$	Low-level input current	IN from 0 V or $V_{CC}$	-10		$\mu$ A	
$C_I$	Input capacitance to ground	IN at $V_{CC}$ , $V_I = 0.4 \sin(4E6\pi t)$		1	pF	
CMTI	Common-mode transient immunity	$V_I = V_{CC}$ or 0 V, See <a href="#">Figure 16</a>	15	40	kV/ $\mu$ s	

(1) For the 3.3-V operation,  $V_{CC1}$  or  $V_{CC2}$  is specified from 3 V to 3.6 V.

## 6.13 Electrical Characteristics—2.8-V $V_{CC1}$ and $V_{CC2}$ Supplies

$V_{CC1}$  and  $V_{CC2}$  at 2.8 V (over recommended operating conditions unless otherwise noted.) 2.8-V operation is only specified for ISO722xC with production screening starting in January 2012. The first two digits of the Lot Trace Code (YMSLLLLG4) written on top of each device can be used to identify year and month of production respectively.

PARAMETER		TEST CONDITIONS	MIN	TYP	MAX	UNIT
$I_{CC1}$	$V_{CC1}$ supply current	ISO7220C quiescent, $V_I = V_{CC}$ or 0 V, no load		0.4	0.9	mA
		ISO7221C quiescent, $V_I = V_{CC}$ or 0 V, no load		3.7	7.5	
		ISO7220C 25 Mbps, 12.5-MHz input clock signal, no load		1.5	3.5	mA
		ISO7221C 25 Mbps, 12.5-MHz input clock signal, no load		4.5	10	
$I_{CC2}$	$V_{CC2}$ supply current	ISO7220C quiescent, $V_I = V_{CC}$ or 0 V, no load		6.8	15	mA
		ISO7221C quiescent, $V_I = V_{CC}$ or 0 V, no load		3.7	7.5	
		ISO7220C 25 Mbps, 12.5-MHz input clock signal, no load		9	17	mA
		ISO7221C 25 Mbps, 12.5-MHz input clock signal, no load		4.5	10	
$V_{OH}$	High-level output voltage	$I_{OH} = -4$ mA, See <a href="#">Figure 14</a>	$V_{CC} - 0.6$	2.55	V	
		$I_{OH} = -20$ $\mu$ A, See <a href="#">Figure 14</a>	$V_{CC} - 0.1$	2.8		
$V_{OL}$	Low-level output voltage	$I_{OL} = 4$ mA, See <a href="#">Figure 14</a>		0.25		0.6
		$I_{OL} = 20$ $\mu$ A, See <a href="#">Figure 14</a>		0		0.1
$V_{I(HYS)}$	Input voltage hysteresis			150	mV	
$I_{IH}$	High-level input current	IN from 0 V or $V_{CC}$			10	$\mu$ A
$I_{IL}$	Low-level input current	IN from 0 V or $V_{CC}$	-10		$\mu$ A	
$C_I$	Input capacitance to ground	IN at $V_{CC}$ , $V_I = 0.4 \sin(4E6\pi t)$		1	pF	
CMTI	Common-mode transient immunity	$V_I = V_{CC}$ or 0 V, See <a href="#">Figure 16</a>	10	30	kV/ $\mu$ s	

## 6.14 Switching Characteristics—5-V $V_{CC1}$ and $V_{CC2}$ Supplies

$V_{CC1}$  and  $V_{CC2}$  at 5 V  $\pm$  10% (over recommended operating conditions unless otherwise noted.)

PARAMETER		TEST CONDITIONS	MIN	TYP	MAX	UNIT
$t_{PLH}$ , $t_{PHL}$	Propagation delay	ISO722xA, see <a href="#">Figure 14</a>	280	405	600	ns
PWD	Pulse-width distortion $ t_{PHL} - t_{PLH} ^{(1)}$		1	18	ns	
$t_{PLH}$ , $t_{PHL}$	Propagation delay	ISO722xB, see <a href="#">Figure 14</a>	42	55	70	ns
PWD	Pulse-width distortion $ t_{PHL} - t_{PLH} ^{(1)}$		1	3	ns	
$t_{PLH}$ , $t_{PHL}$	Propagation delay	ISO722xC, see <a href="#">Figure 14</a>	22	32	42	ns
PWD	Pulse-width distortion $ t_{PHL} - t_{PLH} ^{(1)}$		1	2	ns	
$t_{PLH}$ , $t_{PHL}$	Propagation delay	ISO722xM, see <a href="#">Figure 14</a>	6	10	16	ns
PWD	Pulse-width distortion $ t_{PHL} - t_{PLH} ^{(1)}$		0.5	1	ns	
$t_{sk(pp)}$	Part-to-part skew <sup>(2)</sup>	ISO722xA			180	ns
		ISO722xB			17	
		ISO722xC			10	
		ISO722xM			3	
$t_{sk(o)}$	Channel-to-channel output skew <sup>(3)</sup>	ISO7220A		3	15	ns
		ISO7220B		0.6	3	
		ISO7220C, ISO7220M		0.2	1	
$t_r$	Output signal rise time	See <a href="#">Figure 14</a>		1		ns
$t_f$	Output signal fall time			1		ns
$t_{fs}$	Failsafe output delay time from input power loss	See <a href="#">Figure 15</a>		3		$\mu$ s
$t_{jit(pp)}$	Peak-to-peak eye-pattern jitter	ISO722xM, 150 Mbps PRBS NRZ data, 5-bit max same polarity input, both channels, See <a href="#">Figure 17</a> , <a href="#">Figure 13</a>		1		ns
		ISO722xM, 150 Mbps unrestricted bit run length data input, both channels, See <a href="#">Figure 17</a>		2		

- (1) Also referred to as pulse skew.
- (2)  $t_{sk(pp)}$  is the magnitude of the difference in propagation delay times between any specified pins of two devices when both devices operate with the same supply voltages, at the same temperature, and have identical packages and test circuits.
- (3)  $t_{sk(o)}$  is the skew between specified outputs of a single device with all driving inputs connected together and the outputs switching in the same direction while driving identical specified loads.

## 6.15 Switching Characteristics—5-V $V_{CC1}$ and 3.3-V $V_{CC2}$ Supply

$V_{CC1}$  at 5 V  $\pm$  10%,  $V_{CC2}$  at 3.3 V  $\pm$  10% (over recommended operating conditions unless otherwise noted.)

PARAMETER		TEST CONDITIONS	MIN	TYP	MAX	UNIT
$t_{PLH}$ , $t_{PHL}$	Propagation delay	ISO722xA, see <a href="#">Figure 14</a>	285	410	585	ns
PWD	Pulse-width distortion $ t_{PHL} - t_{PLH} ^{(1)}$			1	18	ns
$t_{PLH}$ , $t_{PHL}$	Propagation delay	ISO722xB, see <a href="#">Figure 14</a>	45	58	75	ns
PWD	Pulse-width distortion $ t_{PHL} - t_{PLH} ^{(1)}$			1	3	ns
$t_{PLH}$ , $t_{PHL}$	Propagation delay	ISO722xC, see <a href="#">Figure 14</a>	25	36	48	ns
PWD	Pulse-width distortion $ t_{PHL} - t_{PLH} ^{(1)}$			1	2	ns
$t_{PLH}$ , $t_{PHL}$	Propagation delay	ISO722xM, see <a href="#">Figure 14</a>	7	12	20	ns
PWD	Pulse-width distortion $ t_{PHL} - t_{PLH} ^{(1)}$			0.5	1	ns
$t_{sk(pp)}$	Part-to-part skew <sup>(2)</sup>	ISO722xA			180	ns
		ISO722xB			17	
		ISO722xC			10	
		ISO722xM			5	
$t_{sk(o)}$	Channel-to-channel output skew <sup>(3)</sup>	ISO7220A		3	15	ns
		ISO7220B		0.6	3	
		ISO7220C, ISO7220M		0.2	1	
$t_r$	Output signal rise time	See <a href="#">Figure 14</a>		2		ns
$t_f$	Output signal fall time			2		ns
$t_{fs}$	Failsafe output delay time from input power loss	See <a href="#">Figure 15</a>		3		$\mu$ s
$t_{jit(pp)}$	Peak-to-peak eye-pattern jitter	ISO722xM, 150 Mbps PRBS NRZ data, 5-bit max same polarity input, both channels, See <a href="#">Figure 17</a> , <a href="#">Figure 13</a>		1		ns
		ISO722xM, 150 Mbps unrestricted bit run length data input, both channels, See <a href="#">Figure 17</a>		2		

- (1) Also referred to as pulse skew.
- (2)  $t_{sk(pp)}$  is the magnitude of the difference in propagation delay times between any specified pins of two devices when both devices operate with the same supply voltages, at the same temperature, and have identical packages and test circuits.
- (3)  $t_{sk(o)}$  is the skew between specified outputs of a single device with all driving inputs connected together and the outputs switching in the same direction while driving identical specified loads.

## 6.16 Switching Characteristics—3.3-V<sub>CC1</sub> and 5-V<sub>CC2</sub> Supplies

V<sub>CC1</sub> at 3.3 V ± 10%, V<sub>CC2</sub> at 5 V ± 10% (over recommended operating conditions unless otherwise noted.)

PARAMETER		TEST CONDITIONS	MIN	TYP	MAX	UNIT
t <sub>PLH</sub> , t <sub>PHL</sub>	Propagation delay	ISO722xA, see <a href="#">Figure 14</a>	285	395	605	ns
PWD	Pulse-width distortion  t <sub>PHL</sub> – t <sub>PLH</sub>   <sup>(1)</sup>			1	22	ns
t <sub>PLH</sub> , t <sub>PHL</sub>	Propagation delay	ISO722xB, see <a href="#">Figure 14</a>	45	58	75	ns
PWD	Pulse-width distortion  t <sub>PHL</sub> – t <sub>PLH</sub>   <sup>(1)</sup>			1	4	ns
t <sub>PLH</sub> , t <sub>PHL</sub>	Propagation delay	ISO722xC, see <a href="#">Figure 14</a>	25	36	48	ns
PWD	Pulse-width distortion  t <sub>PHL</sub> – t <sub>PLH</sub>   <sup>(1)</sup>			1	3	ns
t <sub>PLH</sub> , t <sub>PHL</sub>	Propagation delay	ISO722xM, see <a href="#">Figure 14</a>	7	12	21	ns
PWD	Pulse-width distortion  t <sub>PHL</sub> – t <sub>PLH</sub>   <sup>(1)</sup>			0.5	1	ns
t <sub>sk(pp)</sub>	Part-to-part skew <sup>(2)</sup>	ISO722xA			190	ns
		ISO722xB			17	
		ISO722xC			10	
		ISO722xM			5	
t <sub>sk(o)</sub>	Channel-to-channel output skew <sup>(3)</sup>	ISO7220A		3	15	ns
		ISO7220B		0.6	3	
		ISO7220C, ISO7220M		0.2	1	
t <sub>r</sub>	Output signal rise time	See <a href="#">Figure 14</a>		1		ns
t <sub>f</sub>	Output signal fall time			1		ns
t <sub>fs</sub>	Failsafe output delay time from input power loss	See <a href="#">Figure 15</a>		3		µs
t <sub>jit(pp)</sub>	Peak-to-peak eye-pattern jitter	ISO722xM, 150 Mbps PRBS NRZ data, 5-bit max same polarity input, both channels, see <a href="#">Figure 17</a> , <a href="#">Figure 13</a>		1		ns
		ISO722xM, 150 Mbps unrestricted bit run length data input, both channels, see <a href="#">Figure 17</a>		2		

- (1) Also referred to as pulse skew.
- (2) t<sub>sk(pp)</sub> is the magnitude of the difference in propagation delay times between any specified pins of two devices when both devices operate with the same supply voltages, at the same temperature, and have identical packages and test circuits.
- (3) t<sub>sk(o)</sub> is the skew between specified outputs of a single device with all driving inputs connected together and the outputs switching in the same direction while driving identical specified loads.

## 6.17 Switching Characteristics—3.3-V $V_{CC1}$ and $V_{CC2}$ Supplies

 $V_{CC1}$  and  $V_{CC2}$  at 3.3 V  $\pm$  10% (over recommended operating conditions unless otherwise noted.)

PARAMETER		TEST CONDITIONS	MIN	TYP	MAX	UNIT
$t_{PLH}$ , $t_{PHL}$	Propagation delay	ISO722xA, see Figure 14	290	400	610	ns
PWD	Pulse-width distortion $ t_{PHL} - t_{PLH} ^{(1)}$					
$t_{PLH}$ , $t_{PHL}$	Propagation delay	ISO722xB, see Figure 14	46	62	78	ns
PWD	Pulse-width distortion $ t_{PHL} - t_{PLH} ^{(1)}$					
$t_{PLH}$ , $t_{PHL}$	Propagation delay	ISO722xC, see Figure 14	26	40	52	ns
PWD	Pulse-width distortion $ t_{PHL} - t_{PLH} ^{(1)}$					
$t_{PLH}$ , $t_{PHL}$	Propagation delay	ISO722xM, see Figure 14	8	16	25	ns
PWD	Pulse-width distortion $ t_{PHL} - t_{PLH} ^{(1)}$					
$t_{sk(pp)}$	Part-to-part skew <sup>(2)</sup>	ISO722xA			190	ns
		ISO722xB			17	
		ISO722xC			10	
		ISO722xM			5	
$t_{sk(o)}$	Channel-to-channel output skew <sup>(3)</sup>	ISO7220A		3	15	ns
		ISO7220B		0.6	3	
		ISO7220C, ISO7220M		0.2	1	
$t_r$	Output signal rise time	See Figure 14		2		ns
$t_f$	Output signal fall time			2		ns
$t_{fs}$	Failsafe output delay time from input power loss	See Figure 15		3		$\mu$ s
$t_{jit(pp)}$	Peak-to-peak eye-pattern jitter	ISO722xM, 150 Mbps PRBS NRZ data, 5-bit max same polarity input, both channels, See Figure 17, Figure 13		1		ns
		ISO722xM, 150 Mbps unrestricted bit run length data input, both channels, See Figure 17		2		

- (1) Also referred to as pulse skew.
- (2)  $t_{sk(pp)}$  is the magnitude of the difference in propagation delay times between any specified pins of two devices when both devices operate with the same supply voltages, at the same temperature, and have identical packages and test circuits.
- (3)  $t_{sk(o)}$  is the skew between specified outputs of a single device with all driving inputs connected together and the outputs switching in the same direction while driving identical specified loads.

## 6.18 Switching Characteristics—2.8-V $V_{CC1}$ and $V_{CC2}$ Supplies

 $V_{CC1}$  and  $V_{CC2}$  at 2.8 V (over recommended operating conditions unless otherwise noted.)

PARAMETER		TEST CONDITIONS	MIN	TYP	MAX	UNIT
$t_{PLH}$ , $t_{PHL}$	Propagation delay	ISO722xC, see Figure 14	26	45	65	ns
PWD	Pulse-width distortion $ t_{PHL} - t_{PLH} ^{(1)}$					
$t_{sk(pp)}$	Part-to-part skew <sup>(2)</sup>	ISO722xC			12	ns
$t_{sk(o)}$	Channel-to-channel output skew <sup>(3)</sup>	ISO7220C		0.2	5	ns
$t_r$	Output signal rise time	See Figure 14		2		ns
$t_f$	Output signal fall time			2		ns
$t_{fs}$	Failsafe output delay time from input power loss	See Figure 15		4.6		$\mu$ s

- (1) Also referred to as pulse skew.
- (2)  $t_{sk(pp)}$  is the magnitude of the difference in propagation delay times between any specified pins of two devices when both devices operate with the same supply voltages, at the same temperature, and have identical packages and test circuits.
- (3)  $t_{sk(o)}$  is the skew between specified outputs of a single device with all driving inputs connected together and the outputs switching in the same direction while driving identical specified loads.

## 6.19 Insulation Characteristics Curves

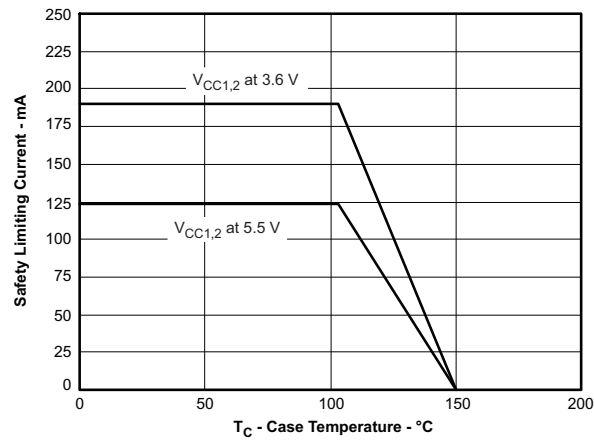

Figure 1. Thermal Derating Curve for Limiting Current per VDE

## 6.20 Typical Characteristics

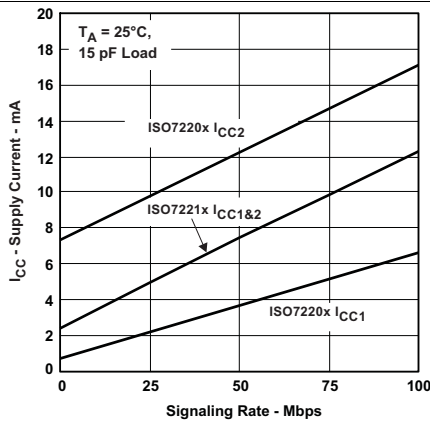

Figure 2. 3.3-V<sub>RMS</sub> Supply Current vs Signaling Rate (Mbps)

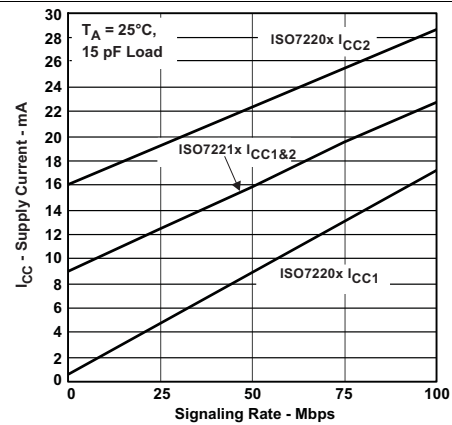

Figure 3. 5-V<sub>RMS</sub> Supply Current vs Signaling Rate (Mbps)

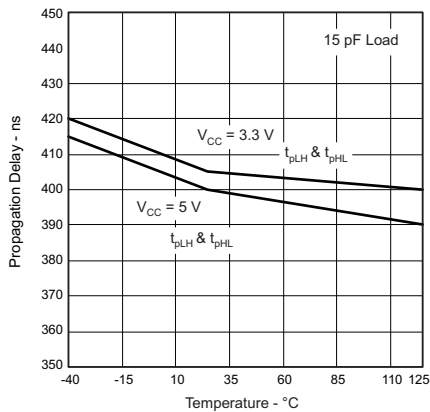

Figure 4. Propagation Delay vs Free-Air Temperature, ISO722xA

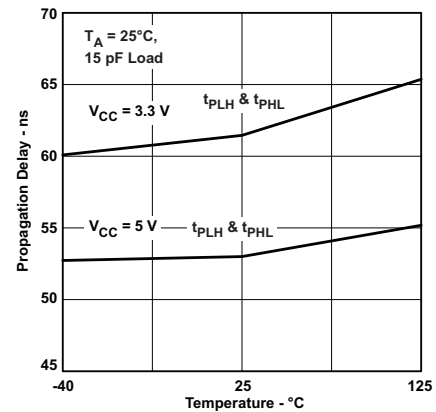

Figure 5. Propagation Delay vs Free-Air Temperature, ISO722xB

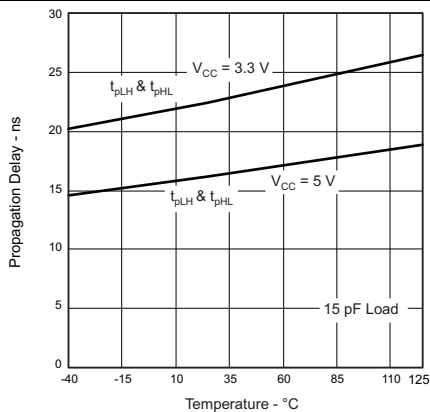

Figure 6. Propagation Delay vs Free-Air Temperature, ISO722xC

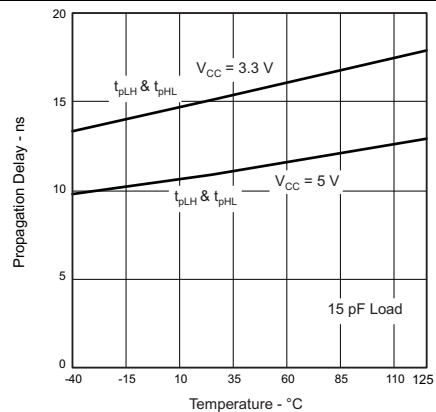

Figure 7. Propagation Delay vs Free-Air Temperature, ISO722xM

Typical Characteristics (continued)

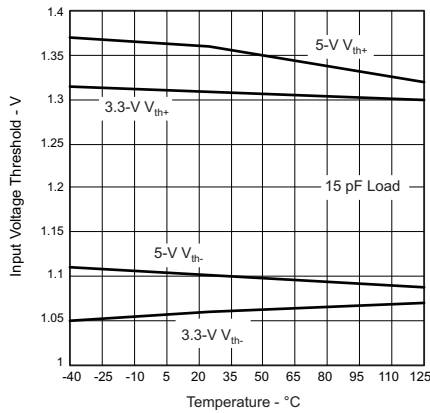

Figure 8. ISO722xA, ISO722xB and ISO722xC Input Voltage Low-to-High Switching Threshold vs Free-Air Temperature

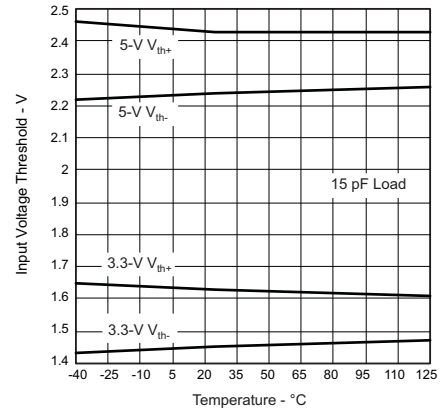

Figure 9. ISO722xM Input Voltage High-to-Low vs Free-Air Temperature

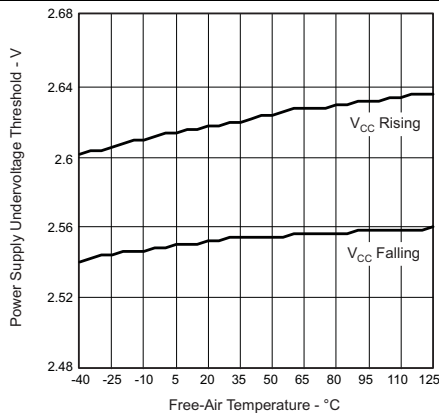

Figure 10. V<sub>CC</sub> Undervoltage Threshold vs Free-Air Temperature

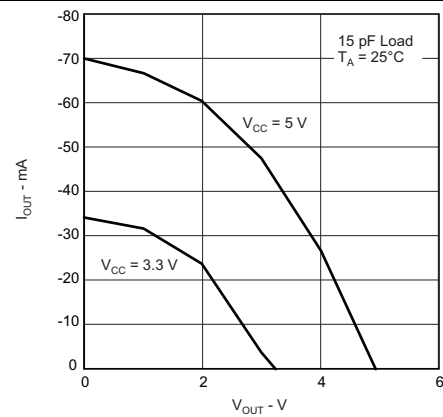

Figure 11. High-Level Output Current vs High-Level Output Voltage

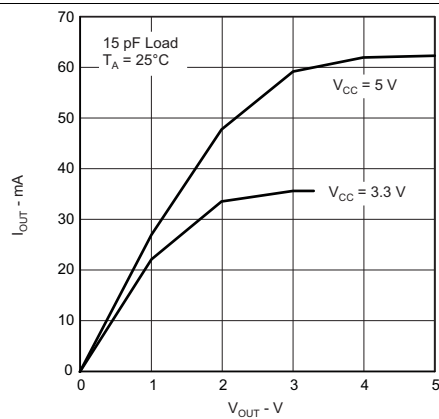

Figure 12. Low-Level Output Current vs Low-Level Output Voltage

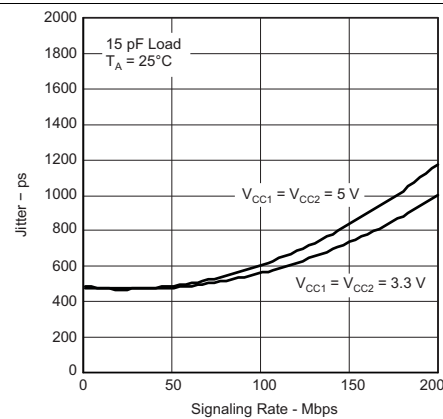
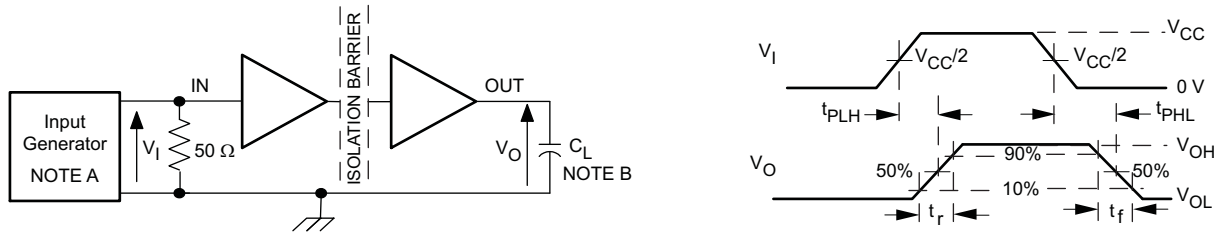

Figure 13. ISO722xM Jitter vs Signaling Rate

## 7 Parameter Measurement Information



- A. The input pulse is supplied by a generator having the following characteristics: PRR  $\leq$  50 kHz, 50% duty cycle,  $t_r \leq$  3 ns,  $t_f \leq$  3 ns,  $Z_O = 50 \Omega$ .
- B.  $C_L = 15$  pF and includes instrumentation and fixture capacitance within  $\pm 20\%$ .

**Figure 14. Switching Characteristic Test Circuit and Voltage Waveforms**

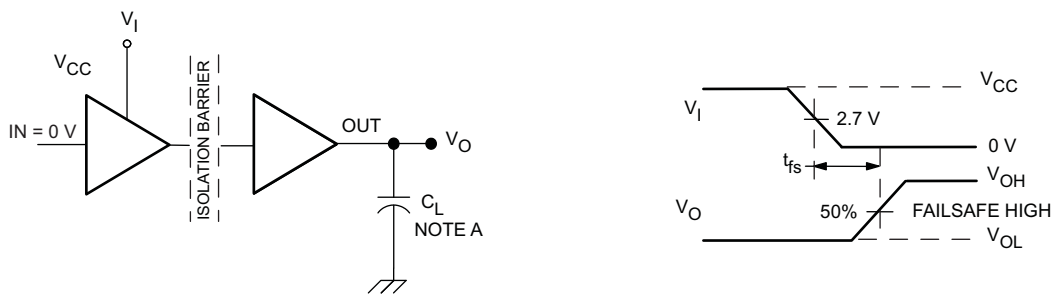

- A.  $C_L = 15$  pF and includes instrumentation and fixture capacitance within  $\pm 20\%$ .

**Figure 15. Failsafe Delay Time Test Circuit and Voltage Waveforms**

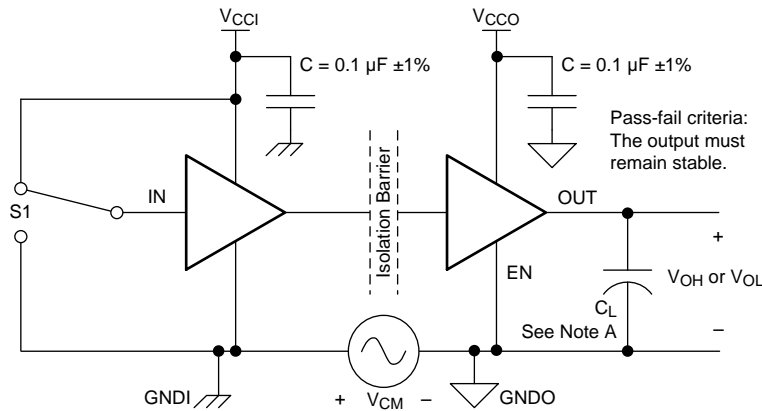

Copyright © 2016, Texas Instruments Incorporated

- A.  $C_L = 15$  pF and includes instrumentation and fixture capacitance within  $\pm 20\%$ .

**Figure 16. Common-Mode Transient Immunity Test Circuit**

### Parameter Measurement Information (continued)

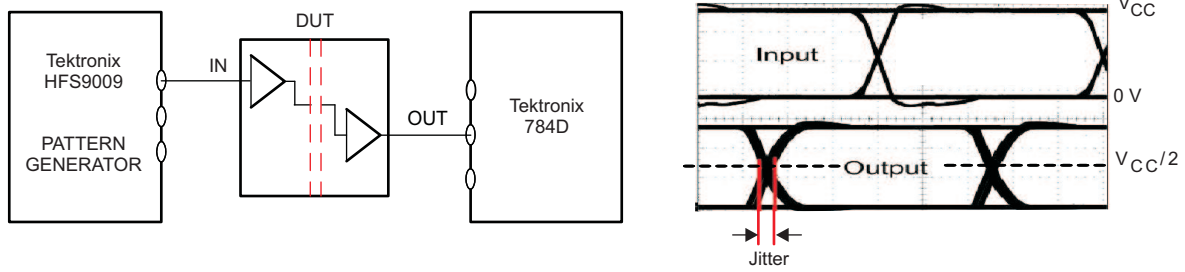

NOTE: PRBS bit pattern run length is  $2^{16} - 1$ . Transition time is 800 ps.

**Figure 17. Peak-to-Peak Eye-Pattern Jitter Test Circuit and Voltage Waveform**

## 8 Detailed Description

### 8.1 Overview

The isolator in the [Functional Block Diagram](#) is based on a capacitive isolation barrier technique. The I/O channel of the ISO7220x and ISO7221x family of devices consists of two internal data channels, a high-frequency channel (HF) with a bandwidth from 100 kbps up to 150 Mbps, and a low-frequency channel (LF) covering the range from 100 kbps down to DC. In principle, a single-ended input signal entering the HF-channel is split into a differential signal via the inverter gate at the input. The following capacitor-resistor networks differentiate the signal into transients, which then are converted into differential pulses by two comparators. The comparator outputs drive a NOR-gate flip-flop whose output feeds an output multiplexer. A decision logic (DCL) at the driving output of the flip-flop measures the durations between signal transients. If the duration between two consecutive transients exceeds a certain time limit, (as in the case of a low-frequency signal), the DCL forces the output-multiplexer to switch from the high-frequency to the low-frequency channel.

Because low-frequency input signals require the internal capacitors to assume prohibitively large values, these signals are pulse-width modulated (PWM) with the carrier frequency of an internal oscillator, thus creating a sufficiently high frequency signal, capable of passing the capacitive barrier. As the input is modulated, a low-pass filter (LPF) is needed to remove the high-frequency carrier from the actual data before passing it on to the output multiplexer.

### 8.2 Functional Block Diagram

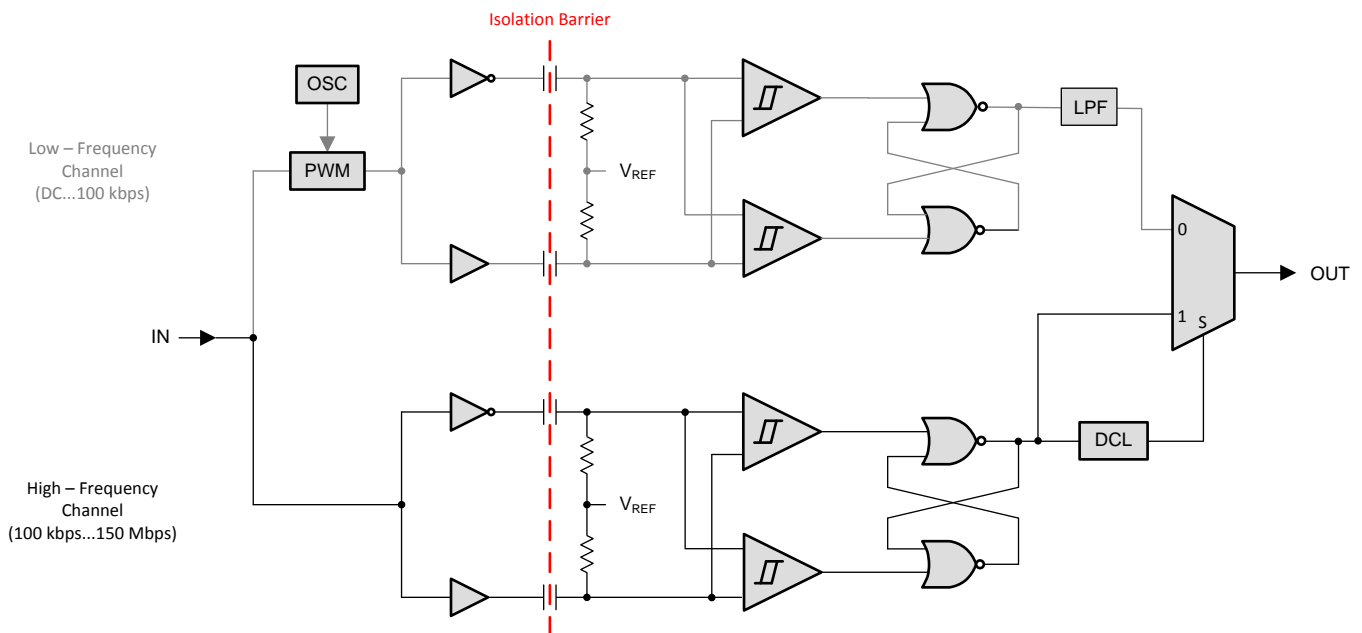

Copyright © 2016, Texas Instruments Incorporated

### 8.3 Feature Description

Table 1 provides an overview of the device features.

**Table 1. Device Features**

PART NUMBER	MAXIMUM SIGNALING RATE	INPUT THRESHOLD	CHANNEL DIRECTION
ISO7220A	1 Mbps	≈ 1.5 V (TTL) (CMOS compatible)	Same direction
ISO7220B	5 Mbps	≈ 1.5 V (TTL) (CMOS compatible)	
ISO7220C	25 Mbps	≈ 1.5 V (TTL) (CMOS compatible)	
ISO7220M	150 Mbps	$V_{CC}/2$ (CMOS)	
ISO7221A	1 Mbps	≈ 1.5 V (TTL) (CMOS compatible)	Opposite directions
ISO7221B	5 Mbps	≈ 1.5 V (TTL) (CMOS compatible)	
ISO7221C	25 Mbps	≈ 1.5 V (TTL) (CMOS compatible)	
ISO7221M	150 Mbps	$V_{CC}/2$ (CMOS)	

### 8.4 Device Functional Modes

The ISO7220x and ISO7221x family of devices functional modes are listed in Table 2.

**Table 2. ISO7220x or ISO7221x Function Table<sup>(1)</sup>**

INPUT SIDE $V_{CC}$	OUTPUT SIDE $V_{CC}$	INPUT (IN)	OUTPUT (OUT)
PU	PU	H	H
		L	L
		Open	H
PD	PU	X	H
X	PD	X	Undetermined

(1) PU = Powered Up ( $V_{CC} \geq 3.0$  V), PD = Powered Down ( $V_{CC} \leq 2.5$  V), X = Irrelevant, H = High Level, L = Low Level

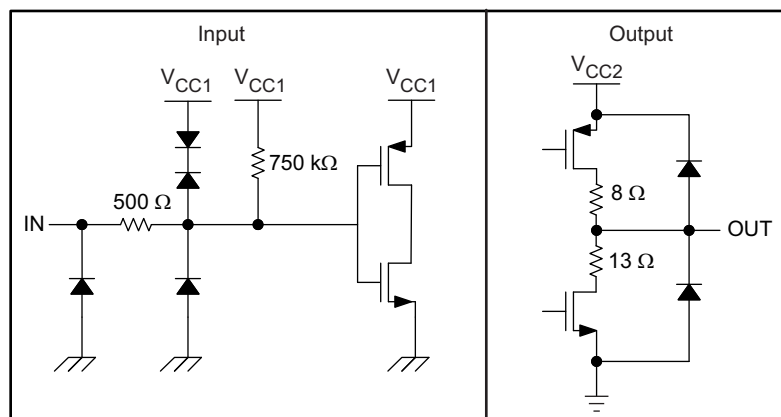

**Figure 18. Device I/O Schematics**

## 9 Application and Implementation

### NOTE

Information in the following applications sections is not part of the TI component specification, and TI does not warrant its accuracy or completeness. TI's customers are responsible for determining suitability of components for their purposes. Customers should validate and test their design implementation to confirm system functionality.

### 9.1 Application Information

The ISO7220x and ISO7221x family devices use single-ended TTL or CMOS-logic switching technology. The supply voltage range is from 3 V (2.8 V for C-grade) to 5.5 V for both supplies,  $V_{CC1}$  and  $V_{CC2}$ . When designing with digital isolators, because of the single-ended design structure, digital isolators do not conform to any specific interface standard and are only intended for isolating single-ended CMOS or TTL digital signal lines. The isolator is typically placed between the data controller (that is,  $\mu$ C or UART), and a data converter or a line transceiver, regardless of the interface type or standard.

### 9.2 Typical Application

The ISO7221x family of devices can be used with Texas Instruments' mixed signal micro-controller, digital-to-analog converter, transformer driver, and voltage regulator to create an isolated 4- to 20-mA current loop.

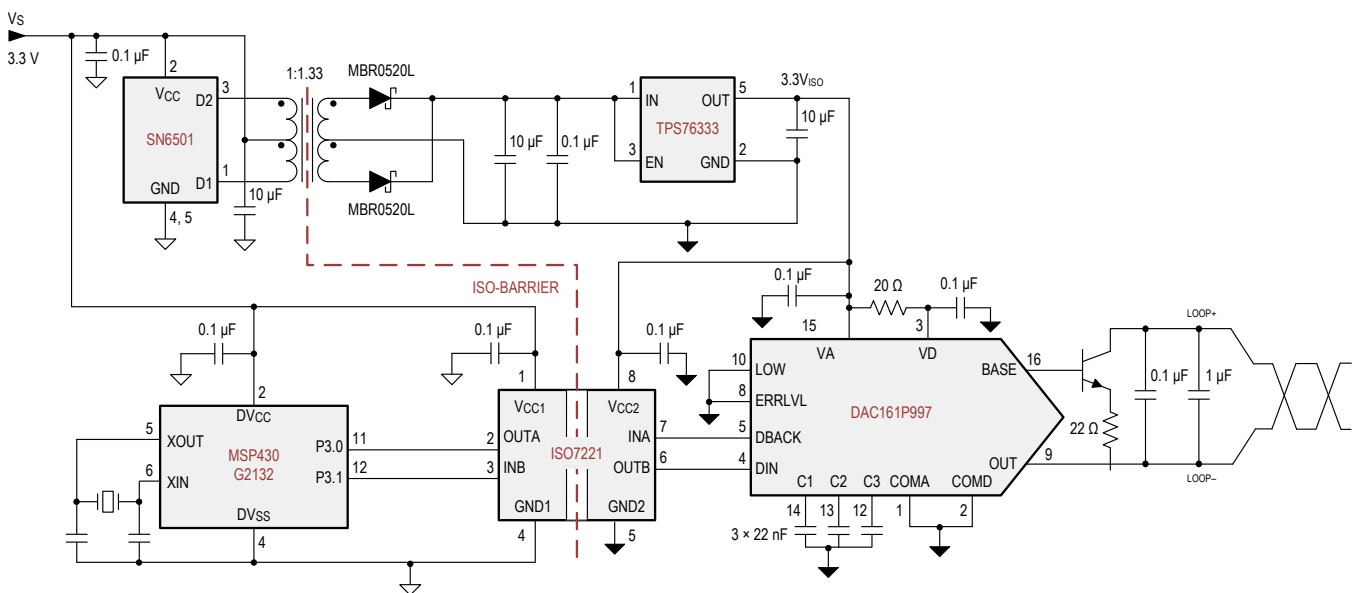

Figure 19. Isolated 4- to 20-mA Current Loop

#### 9.2.1 Design Requirements

Unlike optocouplers, which require external components to improve performance, provide bias (or limit current), the ISO7220x and ISO7221x devices require only two external bypass capacitors to operate.

## Typical Application (continued)

### 9.2.2 Detailed Design Procedure

Figure 20 and Figure 21 show the hookup of a typical ISO7220x and ISO7221x circuit. The only external components are two bypass capacitors.

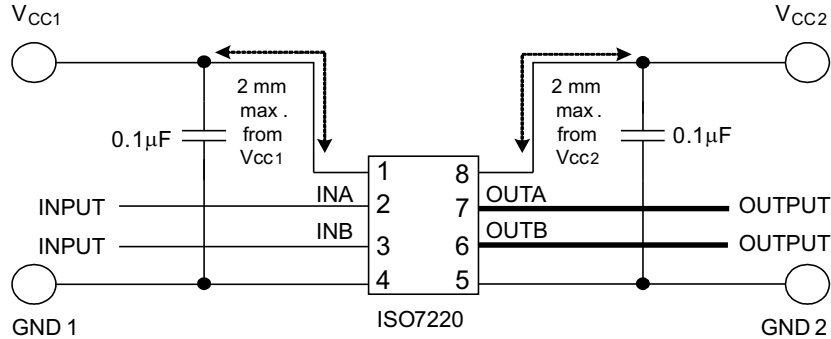

Figure 20. Typical ISO7220x Circuit Hook-Up

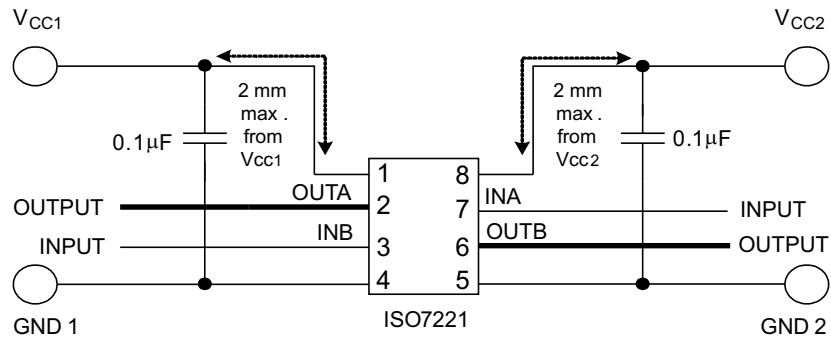

Figure 21. Typical ISO7221x Circuit Hook-Up

### 9.2.3 Application Curve

At maximum working voltage, the isolation barrier of the ISO7220x and ISO7221x family of devices has more than 28 years of life.

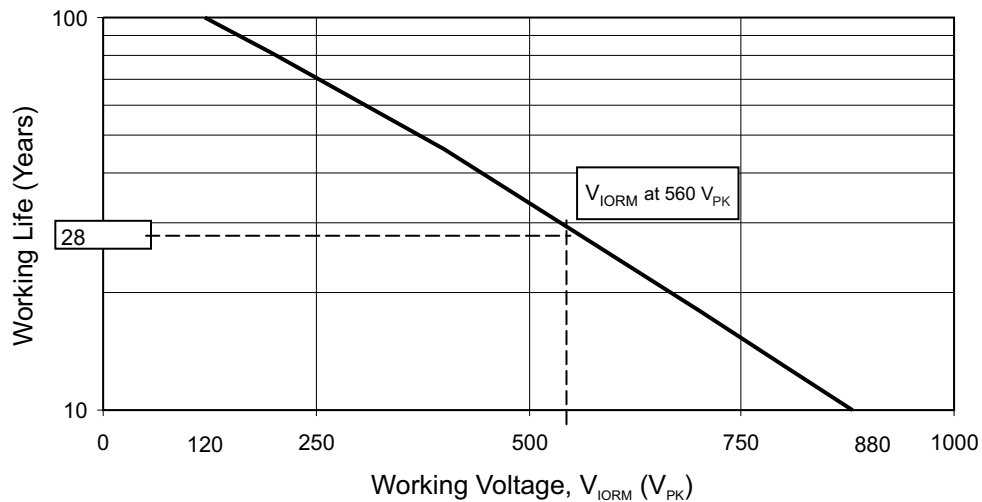

Figure 22. Time-Dependent Dielectric Breakdown Test Results

## 10 Power Supply Recommendations

To help ensure reliable operation at all data rates and supply voltages, a 0.1- $\mu$ F bypass capacitor is recommended at input and output supply pins ( $V_{CC1}$  and  $V_{CC2}$ ). The capacitors should be placed as close to the supply pins as possible. If only a single primary-side power supply is available in an application, isolated power can be generated for the secondary-side with the help of a transformer driver such as Texas Instruments SN6501 device. For such applications, detailed power supply design and transformer selection recommendations are available in [SN6501 Transformer Driver for Isolated Power Supplies](#).

## 11 Layout

### 11.1 Layout Guidelines

A minimum of four layers are required to accomplish a low EMI PCB design (see [Figure 23](#)). Layer stacking should be in the following order (top-to-bottom): high-speed signal layer, ground plane, power plane and low-frequency signal layer.

- Route the high-speed traces on the top layer to avoid the use of vias (and the introduction of the inductances) and allow for clean interconnects between the isolator and the transmitter and receiver circuits of the data link.
- Place a solid ground plane next to the high-speed signal layer to establish controlled impedance for transmission line interconnects and provide an excellent low-inductance path for the return current flow.
- Place the power plane next to the ground plane to create additional high-frequency bypass capacitance of approximately 100 pF/in<sup>2</sup>.
- Route the slower speed control signals on the bottom layer to allow for greater flexibility as these signal links usually have margin to tolerate discontinuities such as vias.

If an additional supply voltage plane or signal layer is needed, add a second power or ground plane system to the stack to keep it symmetrical. Adding a second plane system to the stack makes the stack mechanically stable and prevents it from warping. The power and ground plane of each power system can be placed closer together, thus increasing the high-frequency bypass capacitance significantly.

For detailed layout recommendations, refer to the [Digital Isolator Design Guide](#).

#### 11.1.1 PCB Material

For digital circuit boards operating at less than 150 Mbps, (or rise and fall times greater than 1 ns), and trace lengths of up to 10 inches, use standard FR-4 UL94V-0 printed circuit board. This PCB is preferred over cheaper alternatives because of lower dielectric losses at high frequencies, less moisture absorption, greater strength and stiffness, and the self-extinguishing flammability-characteristics.

#### 11.2 Layout Example

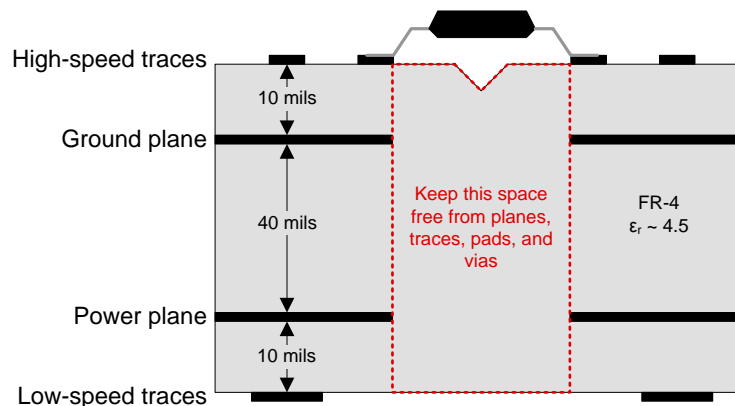

Figure 23. Recommended Layer Stack

## 12 Device and Documentation Support

### 12.1 Device Support

#### 12.1.1 Development Support

For development support, refer to:

- [AC-mains LED Lighting with DALI DMX512 & Power Line Communications Reference Design](#)
- [Industrial Servo Drive and AC Inverter Drive Reference Design](#)
- [Low-Cost Single/Dual-Phase Isolated Electricity Measurement Reference Design](#)
- [Noise Tolerant Capacitive Touch HMI Reference Design](#)
- [Type 2 PoE PSE, 6kV Lightning Surge Reference Design](#)

### 12.2 Documentation Support

#### 12.2.1 Related Documentation

For related documentation, see the following:

- Texas Instruments, [DAC161P997 Single-Wire 16-bit DAC for 4- to 20-mA Loops data sheet](#)
- Texas Instruments, [Digital Isolator Design Guide](#)
- Texas Instruments, [High-Voltage Lifetime of the ISO72x Family of Digital Isolators application report](#)
- Texas Instruments, [Isolation Glossary](#)
- Texas Instruments, [MSP430G2x32 Mixed Signal Microcontroller data sheet](#)
- Texas Instruments, [SN6501 Transformer Driver for Isolated Power Supplies data sheet](#)
- Texas Instruments, [TPS763xx Low-Power 150-mA Low-Dropout Linear Regulators data sheet](#)

### 12.3 Related Links

The table below lists quick access links. Categories include technical documents, support and community resources, tools and software, and quick access to sample or buy.

**Table 3. Related Links**

PARTS	PRODUCT FOLDER	ORDER NOW	TECHNICAL DOCUMENTS	TOOLS & SOFTWARE	SUPPORT & COMMUNITY
ISO7220A	<a href="#">Click here</a>	<a href="#">Click here</a>	<a href="#">Click here</a>	<a href="#">Click here</a>	<a href="#">Click here</a>
ISO7220B	<a href="#">Click here</a>	<a href="#">Click here</a>	<a href="#">Click here</a>	<a href="#">Click here</a>	<a href="#">Click here</a>
ISO7220C	<a href="#">Click here</a>	<a href="#">Click here</a>	<a href="#">Click here</a>	<a href="#">Click here</a>	<a href="#">Click here</a>
ISO7220M	<a href="#">Click here</a>	<a href="#">Click here</a>	<a href="#">Click here</a>	<a href="#">Click here</a>	<a href="#">Click here</a>
ISO7221A	<a href="#">Click here</a>	<a href="#">Click here</a>	<a href="#">Click here</a>	<a href="#">Click here</a>	<a href="#">Click here</a>
ISO7221B	<a href="#">Click here</a>	<a href="#">Click here</a>	<a href="#">Click here</a>	<a href="#">Click here</a>	<a href="#">Click here</a>
ISO7221C	<a href="#">Click here</a>	<a href="#">Click here</a>	<a href="#">Click here</a>	<a href="#">Click here</a>	<a href="#">Click here</a>
ISO7221M	<a href="#">Click here</a>	<a href="#">Click here</a>	<a href="#">Click here</a>	<a href="#">Click here</a>	<a href="#">Click here</a>

### 12.4 Receiving Notification of Documentation Updates

To receive notification of documentation updates, navigate to the device product folder on ti.com. In the upper right corner, click on *Alert me* to register and receive a weekly digest of any product information that has changed. For change details, review the revision history included in any revised document.

### 12.5 Community Resources

The following links connect to TI community resources. Linked contents are provided "AS IS" by the respective contributors. They do not constitute TI specifications and do not necessarily reflect TI's views; see TI's [Terms of Use](#).

**TI E2E™ Online Community** *TI's Engineer-to-Engineer (E2E) Community*. Created to foster collaboration among engineers. At e2e.ti.com, you can ask questions, share knowledge, explore ideas and help

## Community Resources (continued)

solve problems with fellow engineers.

**Design Support** *TI's Design Support* Quickly find helpful E2E forums along with design support tools and contact information for technical support.

## 12.6 Trademarks

E2E is a trademark of Texas Instruments.

DeviceNet is a trademark of Open DeviceNet Vendors Association.

Profibus is a trademark of Profibus.

All other trademarks are the property of their respective owners.

## 12.7 Electrostatic Discharge Caution



This integrated circuit can be damaged by ESD. Texas Instruments recommends that all integrated circuits be handled with appropriate precautions. Failure to observe proper handling and installation procedures can cause damage.

ESD damage can range from subtle performance degradation to complete device failure. Precision integrated circuits may be more susceptible to damage because very small parametric changes could cause the device not to meet its published specifications.

## 12.8 Glossary

[SLYZ022](#) — *TI Glossary*.

This glossary lists and explains terms, acronyms, and definitions.

## 13 Mechanical, Packaging, and Orderable Information

The following pages include mechanical, packaging, and orderable information. This information is the most current data available for the designated devices. This data is subject to change without notice and revision of this document. For browser-based versions of this data sheet, refer to the left-hand navigation.

**PACKAGING INFORMATION**

Orderable Device	Status (1)	Package Type	Package Drawing	Pins	Package Qty	Eco Plan (2)	Lead/Ball Finish (6)	MSL Peak Temp (3)	Op Temp (°C)	Device Marking (4/5)	Samples
ISO7220AD	ACTIVE	SOIC	D	8	75	Green (RoHS & no Sb/Br)	CU NIPDAU	Level-1-260C-UNLIM	-40 to 125	I7220A	<a href="#">Samples</a>
ISO7220ADG4	ACTIVE	SOIC	D	8	75	Green (RoHS & no Sb/Br)	CU NIPDAU	Level-1-260C-UNLIM	-40 to 125	I7220A	<a href="#">Samples</a>
ISO7220ADR	ACTIVE	SOIC	D	8	2500	Green (RoHS & no Sb/Br)	CU NIPDAU	Level-1-260C-UNLIM	-40 to 125	I7220A	<a href="#">Samples</a>
ISO7220ADRG4	ACTIVE	SOIC	D	8	2500	Green (RoHS & no Sb/Br)	CU NIPDAU	Level-1-260C-UNLIM	-40 to 125	I7220A	<a href="#">Samples</a>
ISO7220BD	ACTIVE	SOIC	D	8	75	Green (RoHS & no Sb/Br)	CU NIPDAU	Level-1-260C-UNLIM	-40 to 125	I7220B	<a href="#">Samples</a>
ISO7220BDG4	ACTIVE	SOIC	D	8	75	Green (RoHS & no Sb/Br)	CU NIPDAU	Level-1-260C-UNLIM	-40 to 125	I7220B	<a href="#">Samples</a>
ISO7220BDR	ACTIVE	SOIC	D	8	2500	Green (RoHS & no Sb/Br)	CU NIPDAU	Level-1-260C-UNLIM	-40 to 125	I7220B	<a href="#">Samples</a>
ISO7220BDRG4	ACTIVE	SOIC	D	8	2500	Green (RoHS & no Sb/Br)	CU NIPDAU	Level-1-260C-UNLIM	-40 to 125	I7220B	<a href="#">Samples</a>
ISO7220CD	ACTIVE	SOIC	D	8	75	Green (RoHS & no Sb/Br)	CU NIPDAU	Level-1-260C-UNLIM	-40 to 125	I7220C	<a href="#">Samples</a>
ISO7220CDR	ACTIVE	SOIC	D	8	2500	Green (RoHS & no Sb/Br)	CU NIPDAU	Level-1-260C-UNLIM	-40 to 125	I7220C	<a href="#">Samples</a>
ISO7220MD	ACTIVE	SOIC	D	8	75	Green (RoHS & no Sb/Br)	CU NIPDAU	Level-1-260C-UNLIM	-40 to 125	I7220M	<a href="#">Samples</a>
ISO7220MDG4	ACTIVE	SOIC	D	8	75	Green (RoHS & no Sb/Br)	CU NIPDAU	Level-1-260C-UNLIM	-40 to 125	I7220M	<a href="#">Samples</a>
ISO7220MDR	ACTIVE	SOIC	D	8	2500	Green (RoHS & no Sb/Br)	CU NIPDAU	Level-1-260C-UNLIM	-40 to 125	I7220M	<a href="#">Samples</a>
ISO7220MDRG4	ACTIVE	SOIC	D	8	2500	Green (RoHS & no Sb/Br)	CU NIPDAU	Level-1-260C-UNLIM	-40 to 125	I7220M	<a href="#">Samples</a>
ISO7221AD	ACTIVE	SOIC	D	8	75	Green (RoHS & no Sb/Br)	CU NIPDAU	Level-1-260C-UNLIM	-40 to 125	I7221A	<a href="#">Samples</a>
ISO7221ADG4	ACTIVE	SOIC	D	8	75	Green (RoHS & no Sb/Br)	CU NIPDAU	Level-1-260C-UNLIM	-40 to 125	I7221A	<a href="#">Samples</a>
ISO7221ADR	ACTIVE	SOIC	D	8	2500	Green (RoHS & no Sb/Br)	CU NIPDAU	Level-1-260C-UNLIM	-40 to 125	I7221A	<a href="#">Samples</a>

Orderable Device	Status (1)	Package Type	Package Drawing	Pins	Package Qty	Eco Plan (2)	Lead/Ball Finish (6)	MSL Peak Temp (3)	Op Temp (°C)	Device Marking (4/5)	Samples
ISO7221ADRG4	ACTIVE	SOIC	D	8	2500	Green (RoHS & no Sb/Br)	CU NIPDAU	Level-1-260C-UNLIM	-40 to 125	I7221A	<a href="#">Samples</a>
ISO7221BD	ACTIVE	SOIC	D	8	75	Green (RoHS & no Sb/Br)	CU NIPDAU	Level-1-260C-UNLIM	-40 to 125	I7221B	<a href="#">Samples</a>
ISO7221BDR	ACTIVE	SOIC	D	8	2500	Green (RoHS & no Sb/Br)	CU NIPDAU	Level-1-260C-UNLIM	-40 to 125	I7221B	<a href="#">Samples</a>
ISO7221BDRG4	ACTIVE	SOIC	D	8	2500	Green (RoHS & no Sb/Br)	CU NIPDAU	Level-1-260C-UNLIM	-40 to 125	I7221B	<a href="#">Samples</a>
ISO7221CD	ACTIVE	SOIC	D	8	75	Green (RoHS & no Sb/Br)	CU NIPDAU	Level-1-260C-UNLIM	-40 to 125	I7221C	<a href="#">Samples</a>
ISO7221CDG4	ACTIVE	SOIC	D	8	75	Green (RoHS & no Sb/Br)	CU NIPDAU	Level-1-260C-UNLIM	-40 to 125	I7221C	<a href="#">Samples</a>
ISO7221CDR	ACTIVE	SOIC	D	8	2500	Green (RoHS & no Sb/Br)	CU NIPDAU	Level-1-260C-UNLIM	-40 to 125	I7221C	<a href="#">Samples</a>
ISO7221CDRG4	ACTIVE	SOIC	D	8	2500	Green (RoHS & no Sb/Br)	CU NIPDAU	Level-1-260C-UNLIM	-40 to 125	I7221C	<a href="#">Samples</a>
ISO7221MD	ACTIVE	SOIC	D	8	75	Green (RoHS & no Sb/Br)	CU NIPDAU	Level-1-260C-UNLIM	-40 to 125	I7221M	<a href="#">Samples</a>
ISO7221MDG4	ACTIVE	SOIC	D	8	75	Green (RoHS & no Sb/Br)	CU NIPDAU	Level-1-260C-UNLIM	-40 to 125	I7221M	<a href="#">Samples</a>
ISO7221MDR	ACTIVE	SOIC	D	8	2500	Green (RoHS & no Sb/Br)	CU NIPDAU	Level-1-260C-UNLIM	-40 to 125	I7221M	<a href="#">Samples</a>
ISO7221MDRG4	ACTIVE	SOIC	D	8	2500	Green (RoHS & no Sb/Br)	CU NIPDAU	Level-1-260C-UNLIM	-40 to 125	I7221M	<a href="#">Samples</a>

(1) The marketing status values are defined as follows:

**ACTIVE:** Product device recommended for new designs.

**LIFEBUY:** TI has announced that the device will be discontinued, and a lifetime-buy period is in effect.

**NRND:** Not recommended for new designs. Device is in production to support existing customers, but TI does not recommend using this part in a new design.

**PREVIEW:** Device has been announced but is not in production. Samples may or may not be available.

**OBSELETE:** TI has discontinued the production of the device.

(2) **RoHS:** TI defines "RoHS" to mean semiconductor products that are compliant with the current EU RoHS requirements for all 10 RoHS substances, including the requirement that RoHS substance do not exceed 0.1% by weight in homogeneous materials. Where designed to be soldered at high temperatures, "RoHS" products are suitable for use in specified lead-free processes. TI may reference these types of products as "Pb-Free".

**RoHS Exempt:** TI defines "RoHS Exempt" to mean products that contain lead but are compliant with EU RoHS pursuant to a specific EU RoHS exemption.

**Green:** TI defines "Green" to mean the content of Chlorine (Cl) and Bromine (Br) based flame retardants meet JS709B low halogen requirements of <=1000ppm threshold. Antimony trioxide based flame retardants must also meet the <=1000ppm threshold requirement.

- (3) MSL, Peak Temp. - The Moisture Sensitivity Level rating according to the JEDEC industry standard classifications, and peak solder temperature.
- (4) There may be additional marking, which relates to the logo, the lot trace code information, or the environmental category on the device.
- (5) Multiple Device Markings will be inside parentheses. Only one Device Marking contained in parentheses and separated by a "~" will appear on a device. If a line is indented then it is a continuation of the previous line and the two combined represent the entire Device Marking for that device.
- (6) Lead/Ball Finish - Orderable Devices may have multiple material finish options. Finish options are separated by a vertical ruled line. Lead/Ball Finish values may wrap to two lines if the finish value exceeds the maximum column width.

**Important Information and Disclaimer:**The information provided on this page represents TI's knowledge and belief as of the date that it is provided. TI bases its knowledge and belief on information provided by third parties, and makes no representation or warranty as to the accuracy of such information. Efforts are underway to better integrate information from third parties. TI has taken and continues to take reasonable steps to provide representative and accurate information but may not have conducted destructive testing or chemical analysis on incoming materials and chemicals. TI and TI suppliers consider certain information to be proprietary, and thus CAS numbers and other limited information may not be available for release.

In no event shall TI's liability arising out of such information exceed the total purchase price of the TI part(s) at issue in this document sold by TI to Customer on an annual basis.

**OTHER QUALIFIED VERSIONS OF ISO7220A, ISO7221A, ISO7221C :**

- Automotive: [ISO7220A-Q1](#), [ISO7221A-Q1](#), [ISO7221C-Q1](#)

**NOTE: Qualified Version Definitions:**

- Automotive - Q100 devices qualified for high-reliability automotive applications targeting zero defects

## TAPE AND REEL INFORMATION



### QUADRANT ASSIGNMENTS FOR PIN 1 ORIENTATION IN TAPE



\*All dimensions are nominal

Device	Package Type	Package Drawing	Pins	SPQ	Reel Diameter (mm)	Reel Width W1 (mm)	A0 (mm)	B0 (mm)	K0 (mm)	P1 (mm)	W (mm)	Pin1 Quadrant
ISO7221ADR	SOIC	D	8	2500	330.0	12.4	6.4	5.2	2.1	8.0	12.0	Q1
ISO7221MDR	SOIC	D	8	2500	330.0	12.4	6.4	5.2	2.1	8.0	12.0	Q1

**TAPE AND REEL BOX DIMENSIONS**



\*All dimensions are nominal

Device	Package Type	Package Drawing	Pins	SPQ	Length (mm)	Width (mm)	Height (mm)
ISO7221ADR	SOIC	D	8	2500	350.0	350.0	43.0
ISO7221MDR	SOIC	D	8	2500	350.0	350.0	43.0



D0008A

# PACKAGE OUTLINE

SOIC - 1.75 mm max height

SMALL OUTLINE INTEGRATED CIRCUIT



4214825/C 02/2019

NOTES:

1. Linear dimensions are in inches [millimeters]. Dimensions in parenthesis are for reference only. Controlling dimensions are in inches. Dimensioning and tolerancing per ASME Y14.5M.
2. This drawing is subject to change without notice.
3. This dimension does not include mold flash, protrusions, or gate burrs. Mold flash, protrusions, or gate burrs shall not exceed  $.006$  [0.15] per side.
4. This dimension does not include interlead flash.
5. Reference JEDEC registration MS-012, variation AA.

# EXAMPLE BOARD LAYOUT

D0008A

SOIC - 1.75 mm max height

SMALL OUTLINE INTEGRATED CIRCUIT



LAND PATTERN EXAMPLE  
 EXPOSED METAL SHOWN  
 SCALE:8X



SOLDER MASK DETAILS

4214825/C 02/2019

NOTES: (continued)

- 6. Publication IPC-7351 may have alternate designs.
- 7. Solder mask tolerances between and around signal pads can vary based on board fabrication site.

# EXAMPLE STENCIL DESIGN

D0008A

SOIC - 1.75 mm max height

SMALL OUTLINE INTEGRATED CIRCUIT



SOLDER PASTE EXAMPLE  
BASED ON .005 INCH [0.125 MM] THICK STENCIL  
SCALE:8X

4214825/C 02/2019

NOTES: (continued)

8. Laser cutting apertures with trapezoidal walls and rounded corners may offer better paste release. IPC-7525 may have alternate design recommendations.
9. Board assembly site may have different recommendations for stencil design.

## IMPORTANT NOTICE AND DISCLAIMER

TI PROVIDES TECHNICAL AND RELIABILITY DATA (INCLUDING DATASHEETS), DESIGN RESOURCES (INCLUDING REFERENCE DESIGNS), APPLICATION OR OTHER DESIGN ADVICE, WEB TOOLS, SAFETY INFORMATION, AND OTHER RESOURCES "AS IS" AND WITH ALL FAULTS, AND DISCLAIMS ALL WARRANTIES, EXPRESS AND IMPLIED, INCLUDING WITHOUT LIMITATION ANY IMPLIED WARRANTIES OF MERCHANTABILITY, FITNESS FOR A PARTICULAR PURPOSE OR NON-INFRINGEMENT OF THIRD PARTY INTELLECTUAL PROPERTY RIGHTS.

These resources are intended for skilled developers designing with TI products. You are solely responsible for (1) selecting the appropriate TI products for your application, (2) designing, validating and testing your application, and (3) ensuring your application meets applicable standards, and any other safety, security, or other requirements. These resources are subject to change without notice. TI grants you permission to use these resources only for development of an application that uses the TI products described in the resource. Other reproduction and display of these resources is prohibited. No license is granted to any other TI intellectual property right or to any third party intellectual property right. TI disclaims responsibility for, and you will fully indemnify TI and its representatives against, any claims, damages, costs, losses, and liabilities arising out of your use of these resources.

TI's products are provided subject to TI's Terms of Sale ([www.ti.com/legal/termsofsale.html](http://www.ti.com/legal/termsofsale.html)) or other applicable terms available either on [ti.com](http://ti.com) or provided in conjunction with such TI products. TI's provision of these resources does not expand or otherwise alter TI's applicable warranties or warranty disclaimers for TI products.

Mailing Address: Texas Instruments, Post Office Box 655303, Dallas, Texas 75265  
Copyright © 2019, Texas Instruments Incorporated

## Looking for pricing, stock, or lifecycle information?

Click below to explore more details on WIN SOURCE:

 [View ISO7220ADRG4](#) on WIN SOURCE

 [Texas Instruments](#) Information

## Optimize Your Supply Chain with WIN SOURCE Solutions

-  Global Sourcing Solution
-  Obsolete Management
-  Cost Control Management
-  Shortage Management
-  Alternative Solution
-  Excess Inventory Management